



PMP 400/430 Series Networks PTP 200/230 Series Bridges

Issue 6

August 2011



Notices

See important safety notice on exposure distance in Section 6.3 on page 71.

See important regulatory and legal notices in Section 6 on page 64.

Trademarks, Product Names, and Service Names

MOTOROLA SOLUTIONS, the stylized M Logo, Canopy, and all other trademarks indicated as such herein are registered trademarks of Motorola, Inc. ® Reg. US Pat & Tm. Office. All other product or service names are the property of their respective owners.

© 2011 Motorola Solutions, Inc. All rights reserved

<http://www.motorola.com/canopy>

<http://motorola.wirelessbroadbandsupport.com>

Table of Contents

1	Introduction	6
1.1	Document Change History.....	7
1.2	Abbreviations.....	8
1.3	Feedback on Documentation.....	9
1.4	Technical Support.....	9
2	Product Description	11
2.1	Technology and Benefits	22
2.1.1	<i>nLOS Benefits and Limitations.....</i>	<i>22</i>
2.2	Applications	23
2.3	Configuration Options – RF, IP, DFS.....	24
2.4	Power and Grounding.....	24
2.5	Administration Systems	25
2.6	Specifications	26
2.6.1	<i>Radio specifications (common to all formats)</i>	<i>26</i>
2.6.2	<i>Specifications for PMP 430 (5.4 & 5.8-GHz) SM and PTP 230 (5.4 & 5.8-GHz) BH radio with integrated antenna</i>	<i>27</i>
2.6.3	<i>Specifications for PMP 400 (4.9 & 5.4-GHz) AP/SM and PTP 200 (4.9 & 5.4-GHz) BH radio with integrated antenna</i>	<i>28</i>
2.6.4	<i>Specification for PMP 400/430 AP and PTP 200 BH connectorized radio</i>	<i>29</i>
2.6.5	<i>Specifications for PMP 400/430 kitted, connectorized radio (antenna included).....</i>	<i>29</i>
2.7	Performance.....	31
3	Configuring.....	41
3.1	Link Operation – 1X/2X/3X.....	41
3.2	Transmitter Output Power (and no Jitter).....	42
3.3	Downlink Data %, Range, and Control Slots.....	44
3.4	DFS and Regulatory Parameters for 5.8 & 5.4 GHz Radios.....	46
3.4.1	<i>Background and Operation</i>	<i>46</i>
3.4.2	<i>Setting DFS and Regulatory Parameters.....</i>	<i>48</i>
3.5	External Gain Field.....	52
3.6	Network Control Parameters	53
3.7	Forward Error Correction.....	53
3.8	Cyclic Prefix (Configurable only on PTP 200/230 BH & PMP 430 AP/SM).....	53
4	Installation	55
4.1	Installing an AP with Connectorized Antenna	55

4.2	Installing an SM or BH with an Integrated Antenna.....	62
5	Regulatory and Legal Notices	64
5.1	Important Note on Modifications	64
5.2	National and Regional Regulatory Notices.....	64
5.2.1	<i>U.S. Federal Communication Commission (FCC) Notification</i>	<i>64</i>
5.2.2	<i>Industry Canada (IC) Notification</i>	<i>67</i>
5.2.3	<i>Regulatory Requirements for CEPT Member States (www.cept.org).....</i>	<i>68</i>
5.2.4	<i>European Union Notification for 5.8 GHz Product</i>	<i>69</i>
5.2.5	<i>Equipment Disposal</i>	<i>69</i>
5.2.6	<i>EU Declaration of Conformity for RoHS Compliance.....</i>	<i>69</i>
5.2.7	<i>UK Notification.....</i>	<i>69</i>
5.2.8	<i>Luxembourg Notification.....</i>	<i>69</i>
5.2.9	<i>Czech Republic Notification</i>	<i>70</i>
5.2.10	<i>Greece Notification.....</i>	<i>70</i>
5.2.11	<i>Brazil Notification.....</i>	<i>70</i>
5.2.12	<i>Labeling and Disclosure Table for China</i>	<i>70</i>
5.3	Exposure Separation Distances.....	71
5.3.1	<i>Details of Exposure Separation Distances Calculations and Power Compliance Margins</i>	<i>71</i>
5.4	Legal Notices.....	73
5.4.1	<i>Software License Terms and Conditions</i>	<i>73</i>
5.4.2	<i>Hardware Warranty in US</i>	<i>75</i>
5.5	Limit of Liability.....	75

List of Tables

Table 1:	Motorola PMP 400/430 and PTP 200/230 Series.....	12
Table 2:	5.8GHz OFDM - PMP 430 and PTP 230 Series Model Number Descriptions ..	12
Table 3:	5.4GHz OFDM - PMP 430 Series Model Number Descriptions.....	14
Table 4:	5.4GHz OFDM - PMP 400 and PTP 200/230 Model Number Descriptions	15
Table 5:	4.9GHz OFDM - PMP 400 and PTP 200 Model Number Descriptions	16
Table 6:	CMM4 56VDC and 30 VDC Operation.....	17
Table 7:	Ancillary Equipment and Model Numbers	20
Table 8:	Performance Details	32

Table 9: PMP 400/430 and PTP 200/230 Tx output power	42
Table 10: PMP 400/430 AP Control Slot Settings	45
Table 11: 5.4 / 5.8 GHz OFDM DFS Operation based on Region Code	47
Table 12: US FCC IDs and Industry Canada Certification Numbers and Covered Configurations	65
Table 13: Disclosure Table	71
Table 14: Exposure Separation Distances	71
Table 15: Calculated Exposure Distances and Power Compliance Margins	72

List of Figures

Figure 1: PMP 430 CAP 54430 & 58430	6
Figure 2: PMP 400 CAP 54400 - 5.4 GHz	6
Figure 3: PMP 400 CAP 49400 - 4.9 GHz	6
Figure 4: PMP 430 CSM 54430 & 58430	6
Figure 5: PMP 400 CSM 54400 - 5.4GHz	6
Figure 6: PMP 400 CSM 49400 - 4.9 GHz	6
Figure 7: PTP 200 Integrated	7
Figure 8: PTP 200 Connectorized	7
Figure 9: PTP 230 Integrated	7
Figure 10: CMM4 56 VDC Power Supply	18
Figure 11: CMMmicro and CMM4 30 VDC Power Supply	18
Figure 12: CMM4 - 56 VDC and 30 VDC terminal blocks	18
Figure 13: 600SS Surge Suppression AP and SM diagram	19
Figure 14: LOS, nLOS, and NLOS	23
Figure 15: AP Grounding Lug	25
Figure 16: 600SS pole mount kit	25
Figure 17: PMP 430 SM	28
Figure 18: PMP 430 SM with Optional LENS	28
Figure 19: PMP 400 and PTP 200 radio with integrated antenna	29
Figure 20: PMP 400/430 and PTP 200 BH connectorized radio	29
Figure 21: CAP 49400	30
Figure 22: CAP 58430 and 54430	30
Figure 23: Dynamic Rate Adapt on AP "Configuration => General" page	41
Figure 24: SM Power Level on AP "Home => Session Status" page.	44
Figure 25: Max Range & Downlink Data on AP "Configuration => Radio" page	45

Figure 26: DFS Status on AP "Home => DFS Status" page.	46
Figure 27: Region Code on AP "Configuration => General" page.....	50
Figure 28: Configured Region Code on SM Configuration => General page	51
Figure 29: Active Region Code on SM Home => General Status page.....	51
Figure 30: Ground lug highlighted on AP.....	61
Figure 31: Dielectric Grease – Apply to RJ45 connector	62
Figure 32: Dielectric Grease - Insert Ethernet Cable	63

List of Procedures

Procedure 1: Assembling a 5.8 or 5.4 GHz AP, and attaching to tower	56
Procedure 2: Assembling a 4.9 GHz AP, and attaching to tower	58
Procedure 3: Cabling and Grounding/Earthing the AP.....	61

1 Introduction

This guide provides product configuration information specific to the PMP 400/430 Series networks and PTP 200/230 Series bridges in 5.8-GHz, 5.4-GHz and 4.9-GHz bands. Note: PMP 400 5.4-GHz Series is replaced with PMP 430 5.4-GHz Series.

**PMP 430 Series
– 5.4 & 5.8 GHz**



**Figure 1: PMP 430 CAP
54430 & 58430**



**Figure 4: PMP 430 CSM
54430 & 58430**

**PMP 400 Series
– 5.4 GHz**



**Figure 2: PMP 400 CAP 54400
- 5.4 GHz**



**Figure 5: PMP 400 CSM 54400
- 5.4GHz**

Integrated and Connectorized

**PMP 400 Series
– 4.9 GHz**



**Figure 3: PMP 400 CAP
49400 - 4.9 GHz**



**Figure 6: PMP 400 CSM
49400 - 4.9 GHz**

Integrated and Connectorized

PTP 200 Series Backhauls –5.4 and 4.9 GHz



**Figure 7: PTP 200
Integrated**

PTP 54200 and 49200



**Figure 8: PTP 200
Connectorized**

PTP 54200 and 49200

PTP 230 Series Backhauls –5.4 and 5.8 GHz



**Figure 9: PTP 230
Integrated**

PTP 54230 and 58230

This guide should be used along with the *Motorola PMP Solutions User Guide*, which covers general information, including all network features, RF control features, and GUI (Graphical User Interface) features common across PMP 100, 400, and 500 Series networks and PTP 100 and 200 Series bridges. The *Motorola PMP Solutions User Guide* is available from the “User Guides” section of the Canopy Document Library, <http://motorola.motowi4solutions.com/support/library/?region=1&cat=8>.

This guide assumes that the reader has general RF (Radio Frequency) and Internet Protocol (IP) knowledge and background.

This issue, Issue 6, is consistent with features provided by Canopy Release 11.0.1 (and consistent with features provided by PTP 230 Canopy Release 10.7). Separate Release Notes for each release are available and include open issues and other important information specific to each release.

R11.0.1 and R10.7 Software and software release notes can be downloaded from the Motorola support web site: <http://motorola.wirelessbroadbandsupport.com/software/>.

1.1 DOCUMENT CHANGE HISTORY

- Issue 1 First Issue
- Issue 2 Added the following:
- PTP 200 Series – 5.4-GHz BHs
 - PMP 400 and PTP 200 – Products using AES encryption

- Software Release 8.4.3 features
- Issue 3 Added the following 4.9-GHz public safety band products:
- PTP 200 Series – 4.9-GHz BHs
 - PMP 400 Series – 4.9-GHz APs and SMs
 - Software Release 9.4.2 features
- Issue 4 Added the following:
- Software Release 9.5 features to support PMP 400 and PTP 200
 - PMP 430 Series – 5.8-GHz APs and SMs
 - Software Release 10.0 features to support PMP 430 (10MHz channel)
 - Updated customer support email and phone numbers
- Issue 5 Added the following:
- PMP 430 Series 5.4-GHz AP and SM
 - PMP 430 Series (5.4 and 5.8-GHz OFDM) with Release 10.3
 - Configurable 5, 10 and 20 MHz channel bandwidth
Note: PMP 400 Series 5.4-GHz OFDM supports 10MHz channels.
 - 2.5MHz center channels when configured for 5MHz channel bandwidth
 - Added support for 1/16 Cyclic Prefix in addition to 1/4 and 1/8
Note: PMP 400 Series 5.4-GHz OFDM supports 1/4 Cyclic Prefix
 - Increased Packets Per Second (PPS) from 6,800 to 15,000 PPS
 - 802.1ad Q-in-Q DVLAN (Double VLAN) tagging
 - Dynamic Rate Adapt – configurable (1X, 2X, 3X) uplink/downlink rate
 - PMP 400 and PTP 200 Series with Release 10.3
 - 802.1ad Q-in-Q DVLAN (Double VLAN) tagging
 - Dynamic Rate Adapt – configurable(1X, 2X, 3X) uplink/downlink rate
- Issue 6 Added the following:
- PTP 230 Series 5.4 and 5.8-GHz BHM and BHS

1.2 ABBREVIATIONS

The following abbreviations may be used in these notes:

1X	1X (QPSK) modulation
2X	2X (16 QAM) modulation
3X	3X (64 QAM) modulation
AES	Advanced Encryption Standard
AP	Access Point Module
BH	Backhaul Module, either timing master or timing slave
BHM	Backhaul Module – Master
BHS	Backhaul Module – Slave
CAP	Access Point Module
CIR	Committed Information Rate
CMM	Cluster Management Module (CMM4 or CMMicro)
CNUT	Canopy Network Updater Tool
CSM	Subscriber Module
DES	Data Encryption Standard
DFS	Dynamic Frequency Selection for radar avoidance

DHCP	Dynamic Host Configuration Protocol
DiffServ	Differentiated Services
EIRP	Equivalent Isotropically Radiated Power
ETSI	European Telecommunications Standards Institute
EU	European Union
FCC	Federal Communications Commission (United States)
FSK	Frequency Shift Keying
GHz	Gigahertz
GPS	Global Positioning System
	Note: CMM uses GPS to synchronize APs & BHs
LoS	Line of Sight
MIB	Management Information Base for SNMP
MIR	Maximum Information Rate
NAT	Network Address Translation
nLoS	Near Line of Sight
NLoS	Non Line of Sight
OFDM	Orthogonal Frequency Division Multiplexing
PMP	Point-to-Multi-Point (AP to SMs)
PPS	Packet Per Second
PTP	Point-to-Point (Backhauls)
QAM	Quadrature Amplitude Modulation
QPSK	Quadrature Phase Shift Keying
RF	Radio Frequency
SM	Subscriber Module
VDC	Volts Direct Current
VLAN	Virtual Local Area Network

1.3 FEEDBACK ON DOCUMENTATION

Is this document accurate, complete, and clear? How can it be improved? Please send your feedback on Canopy documentation to technical-documentation@canopywireless.com.

1.4 TECHNICAL SUPPORT

Tip! Do not clear the Event Log after you encounter issues. It may be useful to Technical Support, if you need to escalate the issue.

Here is the escalation path for resolution of a problem:

1. Check documentation:
 - this document
 - Canopy System Release 8 Users Guide, available at <http://motorola.wirelessbroadbandsupport.com/software>.
2. Consider checking the Community Forum and Knowledge Base at <http://motorola.wirelessbroadbandsupport.com/support/community>.
3. Escalate the problem to your Canopy supplier or reseller.
4. Escalate the problem to Canopy Technical Support or other designated Tier 3 technical support:

U.S. and Canada**Email:** technical-support@canopywireless.com
1-866-961-9288**Latin and Central America****Email:** technical-support@canopywireless.com

Argentina	0800-666-2789
Brazil	0800-891-4360
Columbia	01-800-912-0557
Mexico	001-800-942-7721
Peru	0800-70-086
All other countries	+420 533 336 946

**Europe, Middle East,
and Africa****Email:** essc@motorola.com

Denmark	043682114
France	0157323434
Germany	06950070204
Italy	0291483230
Lithuania	880 030 828
Netherlands	0202061404
Norway	24159815
Portugal	0217616160
Spain	0912754787
Russia	810 800 228 41044
Saudi Arabia	800 844 5345
South Africa	0800981900
United Kingdom	0203 0277499

Asia Pacific**Email:** WiBBsupport.apac@motorola.com
+6048503854 (9am - 5pm Malaysia Time)
+420 533 336 946 (outside hours)

When you send e-mail or call, please include, as appropriate, software release on each module, IP addresses, MAC addresses, and features enabled, like NAT, VLAN, high priority channel, or CIR. You may be asked to run the Support Tool on CNUT or Prizm to provide a complete network picture.

2 Product Description

PMP 400/430 Series networks and PTP 200/230 Series bridges add OFDM-based (Orthogonal Frequency Division Multiplexing) products to the Canopy family.

- PMP 430 5.4 and 5.8-GHz SMs as shown in [Figure 4](#) on page 6 use the Canopy SM form factor with an integrated antenna.
- PMP 400 5.4-GHz SMs as shown in [Figure 5](#) on page 6 are available with either an integrated antenna or an external N-type connector on a short length of coaxial cable for connecting to a connectorized antenna.
- PMP 400 5.4-GHz AP and PMP 430 5.4 and 5.8-GHz APs as shown on page 6 are always connectorized, and sold either as a radio with a connectorized antenna as a kit, or as a radio with an external N-type connector on a short length of coaxial cable for connecting to an operator-provided antenna. U.S. customers must use the kit version since the FCC requires the radio to be regulatory certified with the connectorized antenna.
- PTP 200 5.4 and 4.9-GHz BHs as shown in [Figure 7](#) and [Figure 8](#) on page 7 are available with either an integrated antenna or an external N-type connector on a short length of coaxial cable for connecting to a connectorized antenna.
- PTP 230 5.4 and 5.8-GHz BHs as shown in [Figure 9](#) on page 7 use the Canopy SM form factor with an integrated antenna.

PMP 400/430 Series networks are available in multiple bands:

- PMP 58430 APs and SM provide connectivity in the unlicensed 5.8 GHz band.
- PMP 54430 APs and SMs provide connectivity in the unlicensed 5.4 GHz band.
- PMP 54400 APs and SMs provide connectivity in the unlicensed 5.4 GHz band.
- PMP 49400 APs and SMs provide connectivity in the licensed 4.9 GHz band allocated to public safety services. State and local governmental entities are eligible to hold 4.9 GHz licenses.

PTP 200/230 Series networks are available in multiple bands:

- PTP 54200 BHs provide connectivity in the unlicensed 5.4 GHz band.
- PTP 49200 BHs provide connectivity in the licensed 4.9 GHz band allocated to public safety services. State and local governmental entities are eligible to hold 4.9 GHz licenses.
- PTP 54230 BHs provide connectivity in the unlicensed 5.4 GHz band.
- PTP 58230 BHs provide connectivity in the unlicensed 5.8 GHz band.



[Table 1](#) shows the Motorola PMP 400/430 Series and PTP 200/230 Series of products by frequency band, channel bandwidth, cyclic prefix and current software version.

Table 1: Motorola PMP 400/430 and PTP 200/230 Series

Frequency	PMP Series (Point-to-MultiPoint)	PTP Series (Point-To-Point)	Channel Bandwidth		Cyclic Prefix	Software Version	
			PMP Series	PTP Series		PMP Series	PTP Series
5.8 GHz	PMP 430 Series - 58430	PTP 230 Series -58230	5, 10 or 20MHz	10 or 20MHz	1/4, 1/8 or 1/16	11.0.1	10.7
5.4 GHz	PMP 430 Series - 54430	PTP 230 Series -54230	5, 10 or 20MHz	10 or 20MHz	1/4, 1/8 or 1/16	11.0.1	10.7
5.4 GHz	PMP 400 Series - 54400	PTP 200 Series - 54200	10MHz	10MHz	1/4	11.0.1	11.0.1
4.9 GHz	PMP 400 Series - 49400	PTP 200 Series - 49200	10MHz	10MHz	1/4	11.0.1	11.0.1

[Table 2](#) shows the Motorola PMP 430 Series (5.8 GHz OFDM) AP and SM models.

Table 2: 5.8GHz OFDM - PMP 430 and PTP 230 Series Model Number Descriptions

CSM 58430 Model Number	5.8GHz OFDM Subscriber Module (SM) Description	Encryption	Picture	Power 29.5 VDC Supply Type	Specs in Section
5790SM4	5.8 GHz OFDM SM – 4 Mbps	DES			2.6.2
5791SM4	5.8 GHz OFDM SM – 4 Mbps	AES			2.6.2
5790SM10	5.8 GHz OFDM SM – 10 Mbps	DES			2.6.2
5791SM10	5.8 GHz OFDM SM – 10 Mbps	AES			2.6.2
5790SM20	5.8 GHz OFDM SM – 20 Mbps	DES			2.6.2
5791SM20	5.8 GHz OFDM SM – 20 Mbps	AES			2.6.2
5790SM40	5.8 GHz OFDM SM – Uncapped	DES			2.6.2
5791SM40	5.8 GHz OFDM SM – Uncapped	AES			2.6.2

Refer to [Table 7](#) for Models



CAP 58430 Model Number	5.8GHz OFDM Access Point (AP) Description	Encryption	Picture	CMM Type	Specs in Section
5780AP	5.8 GHz OFDM Connectorized AP w/antenna	DES		Requires CMM4 w/56 VDC supply	2.6.5
5780APUS	5.8 GHz OFDM Connectorized AP w/antenna - US Model	DES		Requires CMM4 w/56 VDC supply	2.6.5
5781AP	5.8 GHz OFDM Connectorized AP w/antenna	AES		Requires CMM4 w/56 VDC supply	2.6.5
5781APUS	5.8 GHz OFDM Connectorized AP w/antenna - US Model	AES		Requires CMM4 w/56 VDC supply	2.6.5
5780APC	5.8 GHz OFDM Connectorized AP – No antenna	DES		Requires CMM4 w/56 VDC supply	2.6.4
5781APC	5.8 GHz OFDM Connectorized AP - No antenna	AES		Requires CMM4 w/56 VDC supply	2.6.4
PTP 58230 Model Number	5.8GHz OFDM Backhaul (BH) Description	Encryption	Picture	CMM Type	Specs in Section
5780BH10	5.8 GHz OFDM BH – 10 Mbps	DES		Requires CMM4 w/56 VDC supply	2.6.6
5780BH20	5.8 GHz OFDM BH – 20 Mbps	DES		Requires CMM4 w/56 VDC supply	2.6.6
5780BH50	5.8 GHz OFDM BH – Uncapped	DES		Requires CMM4 w/56 VDC supply	2.6.6
5781BH10	5.8 GHz OFDM BH – 10 Mbps	AES		Requires CMM4 w/56 VDC supply	2.6.6
5781BH20	5.8 GHz OFDM BH – 20 Mbps	AES		Requires CMM4 w/56 VDC supply	2.6.6
5781BH50	5.8 GHz OFDM BH – Uncapped	AES		Requires CMM4 w/56 VDC supply	2.6.6

Table 3 shows the Motorola PMP 430 Series (5.4 GHz OFDM) AP and SM models.

Table 3: 5.4GHz OFDM - PMP 430 Series Model Number Descriptions











CSM 54430 Model Number	5.4GHz OFDM Subscriber Module (SM) Description	Encryption	Picture	Power 29.5 VDC Supply Type	Specs in Section
5490SM4	5.4 GHz OFDM SM – 4 Mbps	DES		 Refer to Table 7 for Models	2.6.2
5491SM4	5.4 GHz OFDM SM – 4 Mbps	AES			2.6.2
5490SM10	5.4 GHz OFDM SM – 10 Mbps	DES			2.6.2
5491SM10	5.4 GHz OFDM SM – 10 Mbps	AES			2.6.2
5490SM20	5.4 GHz OFDM SM – 20 Mbps	DES			2.6.2
5491SM20	5.4 GHz OFDM SM – 20 Mbps	AES			2.6.2
5490SM40	5.4 GHz OFDM SM – Uncapped	DES			2.6.2
5491SM40	5.4 GHz OFDM SM – Uncapped	AES			2.6.2
CAP 54430 Model Number	5.4GHz OFDM Access Point (AP) Description	Encryption	Picture	CMM Type	Specs in Section
5480AP	5.4 GHz OFDM Connectorized AP w/antenna	DES		Requires CMM4 w/56 VDC supply	2.6.5
5480APUS*	5.4 GHz OFDM Connectorized AP w/antenna - US Model	DES		Requires CMM4 w/56 VDC supply	2.6.5
5481AP	5.4 GHz OFDM Connectorized AP w/antenna	AES		Requires CMM4 w/56 VDC supply	2.6.5
5481APUS*	5.4 GHz OFDM Connectorized AP w/antenna - US Model	AES		Requires CMM4 w/56 VDC supply	2.6.5
5480APC	5.4 GHz OFDM Connectorized AP – No antenna	DES		Requires CMM4 w/56 VDC supply	2.6.4
5481APC	5.4 GHz OFDM Connectorized AP - No antenna	AES		Requires CMM4 w/56 VDC supply	2.6.4

Table 4 shows the Motorola PMP 400 and PTP 200/230 Series (5.4 GHz OFDM) models available.

Table 4: 5.4GHz OFDM - PMP 400 and PTP 200/230 Model Number Descriptions

CSM 54400 Model Number	5.4 GHz OFDM Subscriber Module (SM) Description	DES or AES	Picture	Power 29.5 VDC Supply Type	Specs in Section
5440SM	5.4 GHz OFDM SM	DES		 Refer to Table 7 for Models	2.6.3
5441SM	5.4 GHz OFDM SM	AES			2.6.3
5440SMC	5.4 GHz OFDM Connectorized SM	DES			2.6.4
5441SMC	5.4 GHz OFDM Connectorized SM	AES			2.6.4
CAP 54400 Model Number	5.4 GHz OFDM Access Point (AP) Description	DES or AES	Picture	CMM Type	Specs in Section
5440AP	5.4 GHz OFDM Connectorized AP w/antenna	DES		CMMmicro or CMM4	2.6.5
5440APUS	5.4 GHz OFDM Connectorized AP w/antenna - US Model	DES		CMMmicro or CMM4	2.6.5
5441AP	5.4 GHz OFDM Connectorized AP w/antenna	AES		CMMmicro or CMM4	2.6.5
5441APUS	5.4 GHz OFDM Connectorized AP w/antenna - US Model	AES		CMMmicro or CMM4	2.6.5
5440APC	5.4 GHz OFDM Connectorized AP – No Antenna	DES		CMMmicro or CMM4	2.6.4
5441APC	5.4 GHz OFDM Connectorized AP – No Antenna	AES		CMMmicro or CMM4	2.6.4
PTP 54200 Model Number	5.4 GHz OFDM Backhaul (BH) Description	DES or AES	Picture	CMM Type	Specs in Section
5440BH	5.4 GHz OFDM BH	DES		CMMmicro or CMM4	2.6.3
5440BHUS	5.4 GHz OFDM BH – US Model	DES		CMMmicro or CMM4	2.6.3
5441BH	5.4 GHz OFDM BH	AES		CMMmicro or CMM4	2.6.3
5441BHUS	5.4 GHz OFDM BH – US Model	AES		CMMmicro or CMM4	2.6.3
5440BHC	5.4 GHz OFDM Connectorized BH	DES		CMMmicro or CMM4	2.6.4
5440BHCUS	5.4 GHz OFDM Connectorized BH – US Model	DES		CMMmicro or CMM4	2.6.4
5441BHC	5.4 GHz OFDM Connectorized BH	AES		CMMmicro or CMM4	2.6.4
5441BHCUS	5.4 GHz OFDM Connectorized BH – US Model	AES		CMMmicro or CMM4	2.6.4









PTP 54230 Model Number	5.4 GHz OFDM Backhaul (BH) Description	DES or AES	Picture	CMM Type	Specs in Section
5480BH10	5.4 GHz OFDM BH – 10 Mbps	DES		Requires CMM4 w/56 VDC supply	2.6.6
5480BH20	5.4 GHz OFDM BH – 20 Mbps	DES		Requires CMM4 w/56 VDC supply	2.6.6
5480BH50	5.4 GHz OFDM BH – Uncapped	DES		Requires CMM4 w/56 VDC supply	2.6.6
5481BH10	5.4 GHz OFDM BH – 10 Mbps	AES		Requires CMM4 w/56 VDC supply	2.6.6
5481BH20	5.4 GHz OFDM BH – 20 Mbps	AES		Requires CMM4 w/56 VDC supply	2.6.6
5481BH50	5.4 GHz OFDM BH – Uncapped	AES		Requires 56 VDC supply	2.6.6

Table 5 shows the Motorola PMP 400 and PTP 200 Series (4.9 GHz OFDM) AP, SM and BH models.

Table 5: 4.9GHz OFDM - PMP 400 and PTP 200 Model Number Descriptions

CSM 49400 Model Number	4.9 GHz OFDM Subscriber Module (SM) Description	Encryption	Picture	Power 56 VDC Supply Type	Specs in Section
4940SM	4.9 GHz OFDM SM	DES		 Refer to Table 7 for Models	2.6.3
4941SM	4.9 GHz OFDM SM	AES			2.6.3
4940SMC	4.9 GHz OFDM Connectorized SM	DES			2.6.4
4941SMC	4.9 GHz OFDM Connectorized SM	AES			2.6.4
CAP 49400 Model Number	4.9 GHz OFDM Access Point (AP) Module Description	Encryption	Picture	Power 56 VDC CMM Type	Specs in Section
4940AP	4.9 GHz OFDM Connectorized AP w/antenna	DES		Requires CMM4 w/56 VDC supply	2.6.5
4941AP	4.9 GHz OFDM Connectorized AP w/antenna	AES		Requires CMM4 w/56 VDC supply	2.6.5

4940APC	4.9 GHz OFDM Connectorized AP – No antenna	DES		Requires CMM4 w/56 VDC supply	2.6.4
4941APC	4.9 GHz OFDM Connectorized AP – No antenna	AES		Requires CMM4 w/56 VDC supply	2.6.4
PTP 49200 Model Number	4.9 GHz OFDM Backhaul (BH) Description	Encryption	Picture	Power 56 VDC CMM Type	Specs in Section
4940BH	4.9 GHz OFDM BH	DES		Wall type 56VDC supply or CMM4 w/56 VDC supply	2.6.3
4941BH	4.9 GHz OFDM BH	AES		Wall type 56VDC supply or CMM4 w/56 VDC supply	2.6.3
4940BHC	4.9 GHz OFDM Connectorized BH – No antenna	DES		Wall type 56VDC supply or CMM4 w/56 VDC supply	2.6.4
4941BHC	4.9 GHz OFDM Connectorized BH – No antenna	AES		Wall type 56VDC supply or CMM4 w/56 VDC supply	2.6.4

A Cluster Management Module (CMM4) provides GPS synchronization and power to the PMP 400/430 and PTP 200/230 series of products: [Table 6](#) details the power requirements of the APs and BHs.

Table 6: CMM4 56VDC and 30 VDC Operation

Frequency	PMP Series Access Point (AP)	PTP 230 Series Backhaul (BH)	Canopy Custom Power over Ethernet (PoE)
5.8 GHz 5.4 GHz	PMP 430 Series – CAP 58430/54430	PTP 230 Series – PTP 58230/54230	56 VDC - Power on pins 5 & 8, return on pins 4 & 7
5.4 GHz	PMP 400 Series – CAP 54400	PTP 200 Series – PTP 54200	30 VDC - power on pins 7 and 8 and return on pins 4 and 5
4.9 GHz	PMP 400 Series – CAP 49400	PTP 200 Series – PTP 49200	56 VDC - Power on pins 5 & 8, return on pins 4 & 7

The CMM4 can be configured with either or both a 56VDC and a 30VDC external power supply as shown in [Figure 10](#) and [Figure 11](#). The CMM4 must be used for 56 VDC operations which are required for the PMP 430 5.4 and 5.8-GHz AP, PMP 400 4.9-GHz AP, PTP 200 4.9-GHz BH, and PTP 230 5.4 and 5.8-GHz BH. The CMMmicro only supports 30 VDC operations.



Figure 10: CMM4 56 VDC Power Supply



Figure 11: CMMmicro and CMM4 30 VDC Power Supply

Shown in [Figure 12](#) is a CMM4 with labels for the various parts. When using both a 56 VDC and 30 VDC power supply, it is necessary to install a resistor in the 30 VDC terminal blocks. Refer to instructions included with the CMM4.

For details on configuring the CMM4, refer to the *CMM4 User Guide* which is available from the Motorola support web site. <http://motorola.wirelessbroandsupport.com/software/>

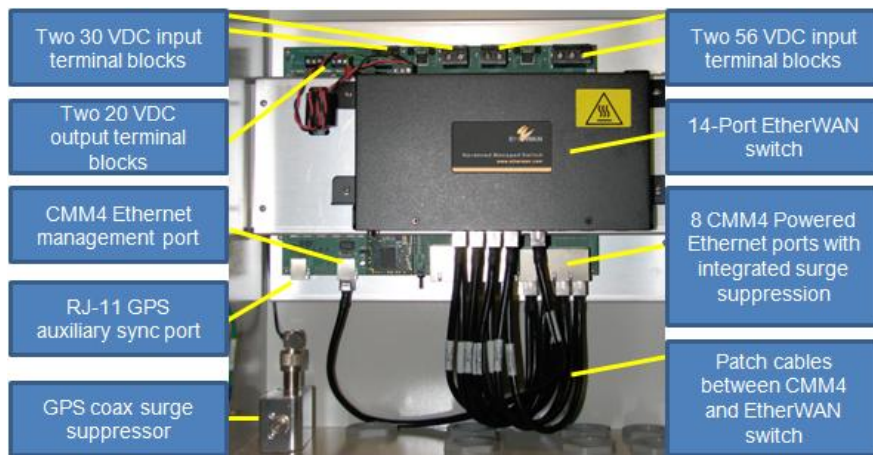

Figure 12: CMM4 - 56 VDC and 30 VDC terminal blocks

A Cluster Management Module (CMMmicro) provides GPS synchronization and 30 VDC power to the:

- 5.4-GHz PMP 400 Series - CAP 54400 uses 30 VDC
- 5.4-GHz PTP 200 Series - PTP 54200 uses 30 VDC

A 600SSD surge suppressor provides over-voltage and over-current protection to APs, SMs, and BHs in various configurations. The diagram in [Figure 13](#) illustrates the use of the 600SS surge suppressor with the PMP 400/430 AP and SM.

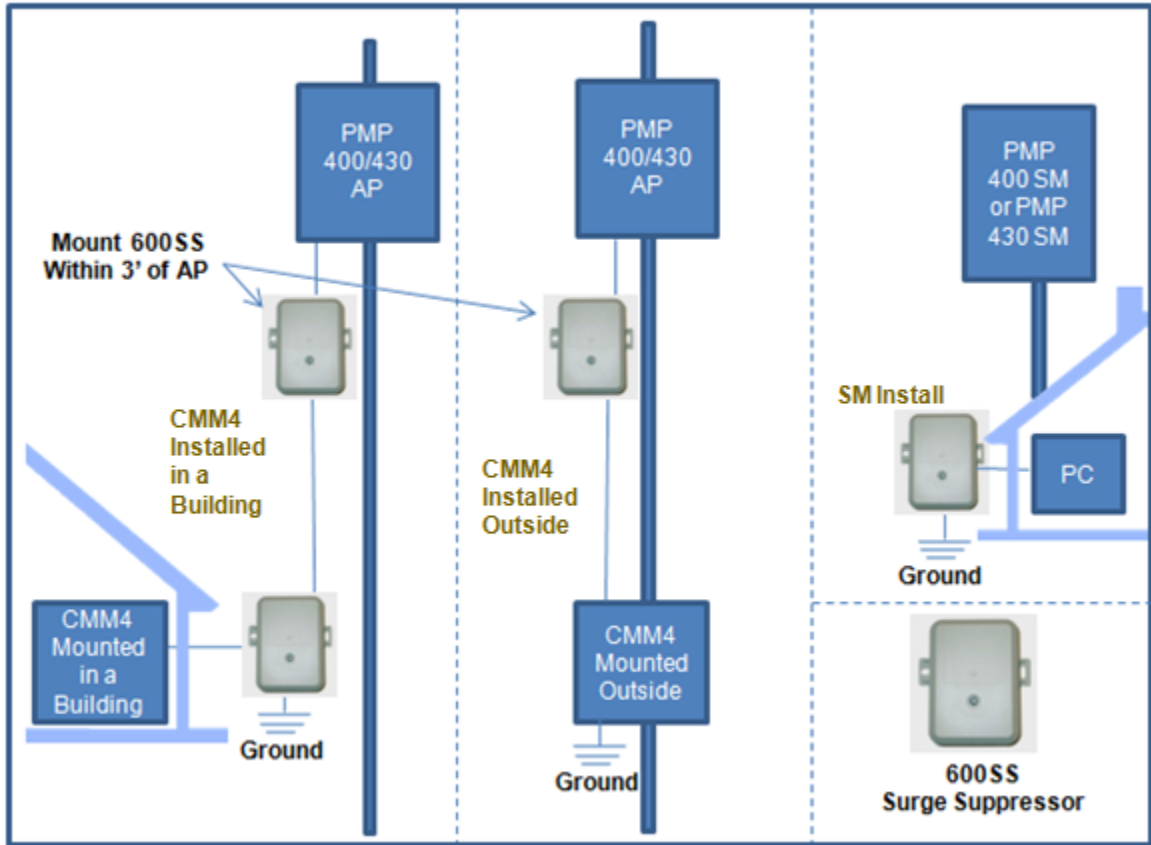









Figure 13: 600SS Surge Suppression AP and SM diagram

Table 7 lists various ancillary equipment and model numbers.

Table 7: Ancillary Equipment and Model Numbers

Name	Model or Part Number	Typically use with								
		C A P	C S M	P T P	C A P	C S M	P T P	C A P	C S M	P T P
		5 x 4 3 0	5 x 4 3 0	5 x 2 3 0	5 4 4 0 0	5 4 4 0 0	5 4 2 0 0	4 9 4 0 0	4 9 4 0 0	4 9 2 0 0
Cluster Management Module micro (CMMmicro – 30 VDC power supply) <ul style="list-style-type: none"> • Controller and 8-port embedded switch • Outdoor enclosure for controller and switch (but not power supply) • 30 VDC power supply included with two models (with 10 ft (3m) DC cable) • GPS antenna and mounting bracket 	 1070CK (with N. American AC cord for power supply) 1070CK-02 (no AC cord) 1070CK-03 (no power supply)				X		X			
CMMmicro or CMM4 30 VDC power supply (w 10 ft (3 m) DC cable)	 ACPS112WA (with N. American AC cord for power supply) APCS112W-02A (no AC cord)				X		X			
PMP 400/430 5.8 & 5.4 GHz SM 29.5 VDC power supply (also for isolated 5.4GHz AP or BH) <ul style="list-style-type: none"> • Includes 6 ft (2m) DC cord • No AC cord needed (plugs directly into AC receptacle) 	 ACPSSW-09B (US, UK, Euro clips) ACPSSW-13B (N. America) ACPSSW-10C (Argentina) ACPWWS-11C (China) ACPSSW-12A (Australia)		X				X			

Name	Model or Part Number	Typically use with								
		C A P	C S M	P T P	C A P	C S M	P T P	C A P	C S M	P T P
		5 x 4 3 0	5 x 4 3 0	5 x 2 3 0	5 4 4 0 0	5 4 4 0 0	5 4 2 0 0	4 9 4 0 0	4 9 4 0 0	4 9 2 0 0
<p>Cluster Management Module 4 (CMM4)</p> <ul style="list-style-type: none"> • Controller and 14-port EtherWAN switch (old version had 9-port EtherWAN switch) • Outdoor enclosure for controller and switch (but not power supply) • No power supply • GPS antenna and mounting bracket 	 <p>1090CK Power supply is not included – Order 56 VDC and/or 30 VDC power supply</p>	X			X		X	X		X
<p>Cluster Management Module (CMM4)</p> <ul style="list-style-type: none"> • Controller ONLY – Without EtherWAN switch • Outdoor enclosure for controller (but not power supply) • GPS antenna and mounting bracket 	<p>1091 Power supply is not included – Order 56 VDC and/or 30 VDC power supply</p>	X			X		X	X		X
<p>56 VDC power supply for CMM4</p> <ul style="list-style-type: none"> • Does not include DC cable or AC line cord – Procure locally 	 <p>SGPN4076</p>	X						X		X
<p>PMP 400 4.9GHz SM 56 VDC power supply (also for standalone use with PMP 430 5.4 and 5.8 GHz AP, PMP 400 4.9 GHz AP or PTP 200 5.4 and 4.9 GHz BH)</p> <ul style="list-style-type: none"> • Includes 6 ft (2m) DC cord • Requires country-specific AC cord 	 <p>SGPN4063A Power cord is not included - Order country specific AC cord</p>									X
<p>4.9 GHz SM 56 VDC power supply AC cords (also for standalone use with PMP 430 5.4 and 5.8 GHz AP, PMP 400 4.9 GHz AP or PTP 200 5.4 and 4.9 GHz BH)</p>	<p>SGKN4427A (US/Canada/Mexico) SGKN4426A (Europe) SGKN4425A (Australia) SGKN4424A (China-Mainland) SGKN4423A (Japan) SGKN4422A (Korea) SGKN4421A (United Kingdom/Singapore) SGKN4420A (India/Pakistan/South Africa) SGKN4419A (Argentina)</p>									X

Name	Model or Part Number	Typically use with								
		C A P	C S M	P T P	C A P	C S M	P T P	C A P	C S M	P T P
		5 x 4 3 0	5 x 4 3 0	5 x 2 3 0	5 4 4 0 0	5 4 4 0 0	5 4 2 0 0	4 9 4 0 0	4 9 4 0 0	4 9 2 0 0
Surge suppressor (AP, SM, BH)	 600SSD	X	X	X	X	X	X	X	X	X
Surge suppressor pole-mount kit Refer to Figure 16 on page 25	SGHN5169A	X		X	X		X	X		X
Radio mounting bracket	 SMMB2A		X		X	X		X	X	

2.1 TECHNOLOGY AND BENEFITS

The radio automatically selects QPSK (Quadrature Phase Shift Keying), 16-QAM (Quadrature Amplitude Modulation), or 64-QAM based on RF environment to provide 1X, 2X, and 3X operation, respectively. This provides 3 speeds and a throughput of over 45 Mbps aggregate (sum of up plus down when configured for 20MHz channel bandwidth) compared to FSK Canopy products with 2 speeds and a throughput of up to 14 Mbps.

The OFDM radios feature lower receive sensitivity, FEC (Forward Error Correction), and higher antenna gain, all of which combine to provide longer range within regulatory-specified EIRP (Equivalent Isotropic Radiated Power).

Details on performance are listed in [Table 8](#) on page [32](#).

The PMP 400 and PTP 200 Series radios use an OFDM physical layer with 10 MHz channels and 256 sub-carriers while the PMP 430 Series radios use an OFDM physical layer with configurable channel bandwidth of 5, 10 or 20MHz. The PTP 230 Series radios use an OFDM physical layer with configurable channel bandwidth of 10 or 20 MHz. A PMP 400 Series 5.4-GHz radio with 10MHz channels will interoperate with a PMP 430 Series 5.4-GHz radio configured with 10MHz channel bandwidth and 1/4 cyclic prefix. However; due to the different carrier and modulation schemes between these OFDM radios and FSK Canopy radios, the two do not interoperate over the air. For example, a PMP 430/400 Series 5.4-GHz OFDM SM cannot connect to a 5.4-GHz FSK AP.

2.1.1 nLOS Benefits and Limitations

In addition to providing LOS (Line-of-Sight) connectivity, use of OFDM technology can provide nLOS (near Line-of-Sight) connectivity and sometimes NLOS (Non-Line-of-Sight) connectivity:

- LOS: the installer can see the AP from the SM and the first Fresnel zone is clear.

- nLOS: the installer can see the AP from the SM, but a portion of the first Fresnel zone is blocked.
- NLOS: the installer cannot see the AP from the SM and a portion or even much of the first Fresnel zone is blocked, but subsequent Fresnel zones are open.

Figure 14 shows examples of LOS, nLOS, and NLOS links.

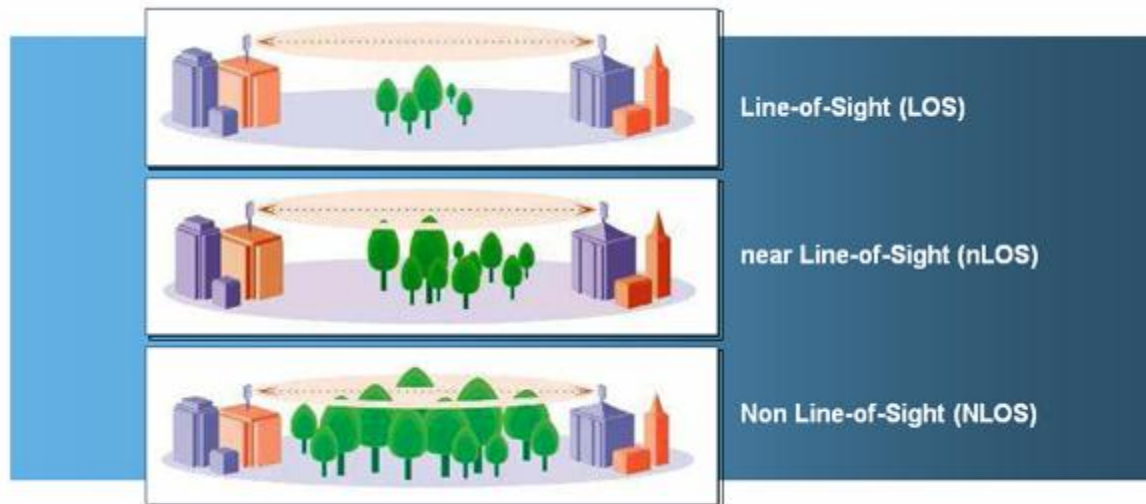

Figure 14: LOS, nLOS, and NLOS

Whereas multi-pathing degrades a link in some technologies (FSK, for example), OFDM can often use multi-pathing to an advantage to overcome nLOS, especially in cases where the Fresnel zone is only partially blocked by buildings, “urban canyons”, or foliage. OFDM tends to help especially when obstacles are near the middle of the link, and less so when the obstacles are very near the SM, AP, or BH.

However, attenuation through walls and trees is substantial for any use of the 5.8 GHz, 5.4 GHz or 4.9 GHz frequency bands. Even with OFDM, these products should not be expected to penetrate walls or extensive trees and foliage.

2.2 APPLICATIONS

Applications for the PMP 400/PTP 200 (5.4-GHz) and PMP 430/PTP 230 (5.4 & 5.8-GHz) Series include:

- High throughput enterprise applications
- nLOS video surveillance in metro areas
- Extend networks into urban areas
- Extend networks into areas with foliage

Applications for the PMP 49400 (4.9-GHz) and PTP 49200 Series systems include:

- High throughput licensed network for government applications
- Municipal network - nLOS video surveillance in metro areas
- Disaster relief network
- Data service network - extend licensed networks into areas with foliage

2.3 CONFIGURATION OPTIONS – RF, IP, DFS

These systems use the Canopy Media Access Controller (MAC) layer. Settings like Downlink Data %, Range, and Control Slots are similar to Canopy FSK radios. An OFDM AP can communicate to over 200 SMs, similar to a Canopy FSK AP.

The GUI (Graphical User Interface) is almost identical to Canopy's FSK products, with a few additions to support OFDM-specific features.

Network features like High Priority using DiffServ, MIR, CIR, NAT, DHCP and VLAN are available for the PMP 400/430 and PTP 200/230 Series OFDM radios, and are configured in the same way as they are for the PMP 100 Series and PTP 100 Series radios.

In the 5.4 and 5.8-GHz band, DFS (Dynamic Frequency Selection) is provided for regulatory compliant operation, and is activated (if required per regulatory rules) using the "Region Code" feature. Two alternate frequencies can be configured to provide service in the unlikely case a module detects radar and triggers DFS, the same as standard Canopy. "External Antenna Gain" may need to be configured consistent with any antennas used, to avoid making the system overly sensitive to radar detection. "Whitening," a technique used to avoid self-interference on Canopy FSK radios, is not offered as an option on the PMP 400/430 and PTP 200/230 Series radios, as whitening is not a technology applicable to an OFDM signal.

2.4 POWER AND GROUNDING

PMP 430 Series APs and PTP 230 BHs use a nominal 56 VDC power system with power on pins 5 and 8 and return on pins 4 and 7. PMP 430 Series APs must use a CMM4 with a 56 VDC power supply. A CMMmicro will not power these units as it is providing the wrong voltage on the wrong pins. PMP 430 Series SMs use a 29.5 VDC wall mount power supply.

PMP 54400 APs and SMs and PTP 54200 BHs use a nominal 30 VDC power system with power on pins 7 and 8 and return on pins 4 and 5. PMP 54400 APs and PTP 54200 BHs can be powered from either a CMMmicro with a 30 VDC power supply or a CMM4 with a 30 VDC power supply. A 29.5 VDC wall mount power supply is available for PMP 54400 SMs.

PMP 49400 APs and SMs and PTP 49200 BHs use a nominal 56 VDC power system with power on pins 5 and 8 and return on pins 4 and 7. PMP 49400 APs and PTP 49200 BHs must use a CMM4 with a 56 VDC power supply. A CMMmicro will not power these units as it is providing the wrong voltage on the wrong pins. A 56 VDC power supply is available for PMP 49400 SMs.



IMPORTANT!

When working on sites with both power systems, use care not to wrongly mix power supplies and radios as the two power systems use different pinouts as well as different voltages.

On sites with a mix of 30 VDC and 56 VDC radios (up to the limit of 8 radios supported by one CMM4), a CMM4 connected to both a 30 VDC power supply and a 56 VDC power supply can be used.

Due to the full metallic connection to the tower or support structure through the AP's antenna or a connectorized BH's antenna, grounding the AP or BH and installing a 600SS surge suppressor within 3 ft (1 m) of the AP or BH (see [Figure 13](#)) is strongly recommended to suppress over voltages and over currents, such as those caused by near-miss lightning. APs and BHs provide a grounding lug, as shown in [Figure 15](#), for grounding to the tower or support structure.



Figure 15: AP Grounding Lug

A pole mount kit (model no. SGHN5169A) is available for the 600SS. The pole mount kit, shown in [Figure 16](#), provides a grounding point on one of its U-bolts that can be used for terminating ground straps from both the 600SS and the AP.

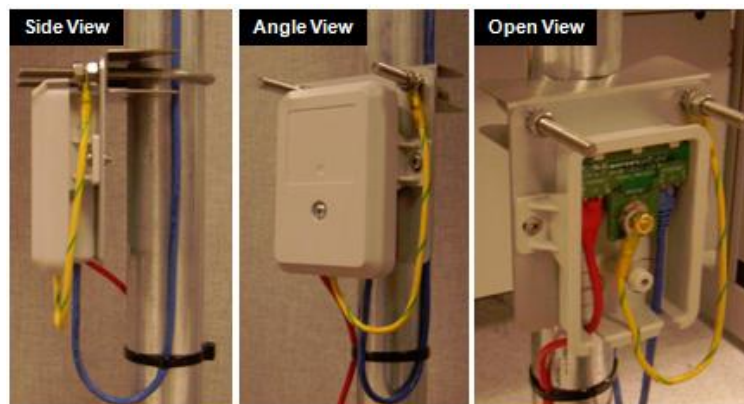

Figure 16: 600SS pole mount kit

2.5 ADMINISTRATION SYSTEMS

Motorola Prizm 3.3 or One Point Wireless Manager v3.0 SP 1 is recommended for managing PMP 400/430 and PTP 200 Series products with Release 11.0.1 and PTP 230 Series products with Release 10.7.

Motorola Prizm 3.3 is available for download from the Motorola support web site:
<http://motorola.wirelessbroadbandsupport.com/software/>

Motorola One Point Wireless Manager v3.0 SP 1 is available for download at:
<http://motorola.wirelessbroandsupport.com/support/opws/software/>

The Motorola Prizm 3.3 element management system is used to manage and monitor Canopy modules and to update module software.

The One Point Wireless Manager v3.0 SP 1 is used to manage and monitor Canopy modules. However; the standalone CNUT tool must be used to upgrade radio software.

CNUT 3.20.18 (Canopy Network Update Tool) is the stand-alone software update tool for PMP 400/430 and PTP 200/230 Series products for operators not using Prizm. CNUT is available at <http://motorola.wirelessbroandsupport.com/software/>.

2.6 SPECIFICATIONS

PMP 430 (5.4 and 5.8-GHz) products are sold in the following formats:

- SM - Radio with integrated antenna
- AP - Kitted, connectorized radio (antenna included)
- AP – Connectorized radio (antenna provided by operator)

PMP 400 (5.4 and 4.9-GHz) and PTP 200 (5.4 and 4.9-GHz) products are sold in the following formats:

- SM/BH - Radio with integrated antenna
- AP/SM/BH - Connectorized radio (antenna provided by operator)
- AP - Kitted, connectorized radio (antenna included)

PTP 230 (5.4 and 5.8-GHz) products are sold in the following format:

- SM/BH - Radio with integrated antenna

The following sections list specifications for each format.

2.6.1 Radio specifications (common to all formats)

Radio Type	Frequency	Settable Transmit (Tx) Output Power Range by Channel Bandwidth		
		5 MHz	10 MHz	20 MHz
PMP 430 AP and PTP 230 BH	5.8 GHz	-30 to +21 dBm	-30 to +21 dBm	-30 to +21 dBm
PMP 430 AP and PTP 230 BH	5.4 GHz	-30 to +21 dBm	-30 to +21 dBm	-30 to +21 dBm
PMP 400 AP and PTP 200 BH	5.4 GHz	N/A	-30 to +12 dBm	N/A
PMP 400 AP and PTP 200 BH	4.9 GHz	N/A	-30 to +18 dBm	N/A

SM	4.9, 5.4 and 5.8-GHz	SM Auto Transmit Power Control (TPC) with power set by the AP to provide power leveling for close-in SMs
----	----------------------	--

- PMP 430 AP/SM: configurable channel bandwidth: 5, 10 or 20MHz
- PMP 430 AP/SM: configurable cyclic prefix (1/4, 1/8 or 1/16)
- PMP 430 AP: Max range 1-30 miles for 5 and 10MHz channel bandwidth, 1-24 miles for 20MHz channel bandwidth
- PMP 400 AP: Max range 1-30 miles
- PMP 400 AP/SM and PTP 200 BH: channel bandwidth fixed at 10MHz
- PMP 400 AP/SM: cyclic prefix fixed at 1/4
- PTP 200 BH: configurable cyclic prefix (1/4 or 1/8)
- PTP 230 BH: configurable channel bandwidth: 10 or 20MHz
- PTP 230 BH: configurable cyclic prefix (1/4, 1/8 or 1/16)
- PTP 230 BH: Max range 1-30 miles for 10MHz channel bandwidth, 1-24 miles for 20MHz channel bandwidth
- Under 22 W DC power
- Environment range of -40°C to +55°C (-40°F to +131°F); 0 to 95% relative humidity, non-condensing
- PMP 400/430 and PTP 200/230 products are available with either DES or AES encryption

2.6.2 Specifications for PMP 430 (5.4 & 5.8-GHz) SM and PTP 230 (5.4 & 5.8-GHz) BH radio with integrated antenna

- Radio with an integrated, internal vertically polarized antenna
- 1 lb, 11.75 x 3.4 x 3.4 in (hwd) or ~.45 kg, 29.9 x 8.6 x 8.6 cm (hwd)
- PMP 430 Configurable channel bandwidth: 5, 10 or 20MHz
- PTP 230 Configurable channel bandwidth: 10 or 20MHz
- Configurable cyclic prefix: 1/4, 1/8 or 1/16
- 10 dBi patch antenna - 55° x 55° and 3 dB beam width
- Optional LENS mounts directly to SM or BH– No additional mounting hardware required
 - adds 6 dBi to 10 dB internal patch antenna which can increase range
 - narrows beam width by 3x (from 55° to 18°) which can reduce interference caused by multi-path reflections
 - LENS part number: AN500A
- Optional Reflector dish
 - adds 15 dBi to 10 dB internal patch antenna which can increase range
 - narrows beam width (from 55° to 6°) which can reduce interference caused by multi-path reflections

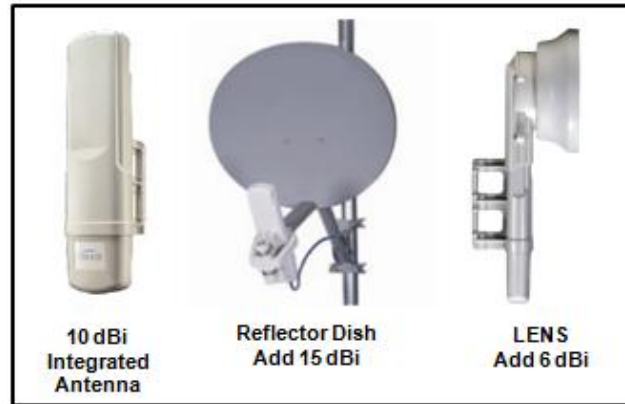

Figure 17: PMP 430 SM

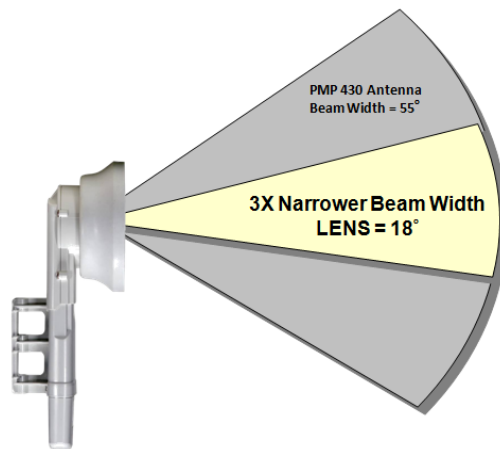

Figure 18: PMP 430 SM with Optional LENS

2.6.3 Specifications for PMP 400 (4.9 & 5.4-GHz) AP/SM and PTP 200 (4.9 & 5.4-GHz) BH radio with integrated antenna

- Radio with an integrated, internal vertically polarized antenna
- 10MHz channel bandwidth
- 1/4 Cyclic Prefix
- 15.5° elevation x 17.5° azimuth -- 3 dB beam
- 17 dBi gain for antenna at 5.4 GHz. 17 dBi antenna gain plus 10 dBm transmit power gives the regulatory maximum of 27 dBm EIRP.
- 17 dBi gain for antenna at 4.9 GHz. 17 dBi antenna gain plus 18 dBm transmit power gives 35 dBm EIRP.
- 2.8 lb, 13.25 x 8.25 x 4.38 in (hwd) or ~1.3 kg, 33.7 x 21 x 11.13 cm (hwd)



Figure 19: PMP 400 and PTP 200 radio with integrated antenna

2.6.4 Specification for PMP 400/430 AP and PTP 200 BH connectorized radio

- Connectorized radio only with N-type connector (antenna to be provided by operator)
- 2.8 lb, 13.25 x 8.25 x 4.38 in (hwd) or ~1.3 kg, 33.7 x 21 x 11.13 cm (hwd)



Figure 20: PMP 400/430 and PTP 200 BH connectorized radio

2.6.5 Specifications for PMP 400/430 kitted, connectorized radio (antenna included)

- Connectorized radio (N-type connector) and connectorized antenna kitted together
- Antenna optimized for system coverage vs. system self-interference for 90° sectors (3 dB beam pattern of 60° azimuth by 5° elevation, with near-in null fill)
- 5.8 GHz - 18 dBi gain for antenna. 18 dBi antenna gain minus 1 dB cable loss plus:
 - 19 dBm tx power gives the U.S. regulatory max 36 dBm EIRP. (5, 10 or 20 MHz Channel)
 - 13 dBm tx power gives the Europe regulatory max 30 dBm EIRP. (5MHz Channel)
 - 16 dBm tx power gives the Europe regulatory max 33 dBm EIRP. (10MHz Channel)
 - 19 dBm tx power gives the Europe regulatory max 36 dBm EIRP. (20MHz Channel)
- 5.4 GHz - 18 dBi gain for antenna. 18 dBi antenna gain minus 1 dB cable loss plus:
 - 7 dBm tx power gives the U.S./Europe regulatory max 24 dBm EIRP. (5MHz Channel)

- 10 dBm tx power gives the U.S./Europe regulatory max 27 dBm EIRP. (10MHz Channel)
- 13 dBm tx power gives the U.S./Europe regulatory max 30 dBm EIRP. (20MHz Channel)
- 4.9 GHz - 17 dBi gain for antenna. 17 dBi antenna gain plus 18 dBm tx power gives 35 dBm EIRP.
- 13 lb, 28 x 8.25 x 11 in (hwd) or ~6 kg, 71 x 21 x 28 cm (hwd)



Figure 21: CAP 49400



Figure 22: CAP 58430 and 54430

2.7 PERFORMANCE

[Table 8](#) shows performance details for PMP 400/430 and PTP 200/230 series. Round trip latency is 5-7 msec for all platforms.

Table 8: Performance Details

Product	Parameter		Performance Details			
			1X	2X	3X	
PMP 58430 5.8 GHz OFDM and PMP 54430 5.4-GHz OFDM	Modulation		QPSK	16 QAM	64 QAM	
	5.8-GHz Max. LOS Range	with Integrated SM antenna	6.4 miles / 10.24 km	5 miles / 8 km	2.3 miles / 3.68 km	
		with LENS that adds 6 dB to SM Range	13 miles / 20.8 km	10 miles / 16 km	4.5 miles / 7.2 km	
		with Reflector Dish that adds 15 dB to SM Range	30 miles / 48 km	29 miles / 46.4 km	13 miles / 20.8 km	
	5.4-GHz Max. LOS Range	with Integrated SM antenna	3.4 miles / 5.44 km	2.7 miles / 4.32 km	1.2 miles / 1.92 km	
		with LENS that adds 6 dB to SM Range	6.8 miles / 10.88 km	5.4 miles / 8.64 km	2.4 miles / 3.84 km	
		with Reflector Dish that adds 15 dB to SM Range	7.6 miles / 12.16 km	6 miles / 9.6 km	2.7 miles / 4.32 km	
	5.4 and 5.8-GHz Max. Aggregate Throughput with 1/16 Cyclic Prefix	5MHz Channel: (up+down)	3.5 Mbps	7 Mbps	10.5 Mbps	
		10 MHz Channel: (up+down)	7.5 Mbps	15 Mbps	22.5 Mbps	
		20 MHz Channel: (up+down)	16.5 Mbps	32 Mbps	45+ Mbps	
	5.4 and 5.8-GHz Nominal Receive Sensitivity (including FEC)	5MHz Channel	-93 dBm	-86 dBm	-79 dBm	
		10MHz Channel	-90 dBm	-83 dBm	-76 dBm	
		20MHz Channel	-87 dBm	-80 dBm	-73 dBm	
	PTP 58230 5.8 GHz OFDM and PTP 54230 5.4-GHz OFDM	Modulation		QPSK	16 QAM	64 QAM
		5.8-GHz Max. LOS Range	with Integrated BH antenna	6.4 miles / 10.24 km	5 miles / 8 km	2.3 miles / 3.68 km
with LENS that adds 6 dB to BHRange			13 miles / 20.8 km	10 miles / 16 km	4.5 miles / 7.2 km	
with Reflector Dish that adds 15 dB to BH Range			30 miles / 48 km	29 miles / 46.4 km	13 miles / 20.8 km	
5.4-GHz Max. LOS Range		with Integrated BH antenna	3.4 miles / 5.44 km	2.7 miles / 4.32 km	1.2 miles / 1.92 km	
		with LENS that adds 6 dB to BH Range	6.8 miles / 10.88 km	5.4 miles / 8.64 km	2.4 miles / 3.84 km	
		with Reflector Dish that adds 15 dB to BH Range	7.6 miles / 12.16 km	6 miles / 9.6 km	2.7 miles / 4.32 km	
5.4 and 5.8-GHz Max. Aggregate Throughput with 1/16 Cyclic Prefix		10 MHz Channel: (up+down)	7.5 Mbps	15 Mbps	23 Mbps	
		20 MHz Channel: (up+down)	17 Mbps	34 Mbps	50 Mbps	
5.4 and 5.8-GHz Nominal Receive Sensitivity (including FEC)		10MHz Channel	-90 dBm	-83 dBm	-76 dBm	
		20MHz Channel	-87 dBm	-80 dBm	-73 dBm	

PMP 54400 PTP 54200 5.4 GHz OFDM	Modulation	QPSK	16 QAM	64 QAM
	Maximum LOS Range with integrated SM antenna Note: LENS and Reflector cannot be used.	5 miles / 8 km	3.4 miles / 5.5 km	1.4 miles/ 2.25 km
	10 MHz Channel: (up+down) Max. Aggregate Throughput with 1/4 cyclic prefix	7.5 Mbps	14 Mbps	PMP: 20.3 Mbps PTP: 21 Mbps
	Nominal Receive Sensitivity (including FEC)	-89 dBm	-78 dBm	-70 dBm
PMP 49400 PTP 49200 4.9 GHz OFDM	Modulation	QPSK	16 QAM	64 QAM
	Maximum LOS Range with integrated SM antenna Note: LENS and Reflector cannot be used.	10 miles / 16 km	4 miles / 6.4 km	1.4 miles / 2.25 km
	10 MHz Channel: (up+down) Max. Aggregate Throughput with 1/4 cyclic prefix	7.5 Mbps	14 Mbps	20.3 Mbps
	Nominal Receive Sensitivity (including FEC)	-89 dBm	-78 dBm	-70 dBm

3 Planning

PMP 400 and PTP 200 Series systems use 10 MHz channel bandwidth configurable on 5 MHz channel centers while the PMP 430 Series is configurable with a 5, 10 or 20 MHz channel bandwidth and the PTP 230 Series is configurable with a 10 or 20 MHz channel bandwidth. When a PMP 430 is configured with 5 MHz channel bandwidth, the radio is configurable on 2.5 MHz center channels and is configurable on 5 MHz center channels when it is configured for either 10 or 20 MHz channel bandwidth.

This channel size, along with some different characteristics due to the use OFDM carrier technology and QPSK, 16 QAM, or 64 QAM modulations, supports somewhat different channel planning than for standard Canopy. (For reference, PMP 100 Series uses 20 MHz channels configurable on 5 MHz centers, single carrier technology, and 2-level and 4-level FSK modulation.)

3.1 TOWER CHANNEL PLANNING

For a single cluster of 4 APs on a tower, 2-channel re-use with channels on 10 MHz channel center spacing gives good performance. In channel design parlance, this can be stated as ABAB channel planning, with no guard band needed between A and B. A typical arrangement might be to use radios configured for 5480 MHz aimed north and south, and radios configured for 5490 MHz aimed east and west.

Available 5.8 GHz channel center frequencies for each region are shown in [Table 9](#). These vary by region due to different band edge RF specifications (for example, between Canada/US and Europe).

Table 9: 5.8 GHz Channel Center Frequencies, by Region

Channel Bandwidth	Region(s)	Range of Center Frequencies Available (MHz)	Center Channel Spacing	# of center channels	# of non-overlapping channels
5MHz	United States, Canada, Australia, Brazil and Russia	5727.5 –5845	2.5MHz	48	24
	Europe and Other	5727.5 –5872.5	2.5MHz	59	30
	India	5827.5 –5872.5	2.5MHz	19	10
10MHz	United States, Canada, Australia, Brazil and Russia	5730 – 5845	5MHz	24	12
	Europe and Other	5730 – 5870	5MHz	29	15
	India	5830 – 5870	5MHz	9	5
20MHz	United States, Canada, Australia, Brazil and Russia	5735 – 5840	5MHz	22	6
	Europe and Other	5735 – 5865	5MHz	27	7
	India	5835 – 5865	5MHz	7	2
20MHz FSK (for comparison)	United States, Canada, Europe and Australia	5735 – 5840	5MHz	22	6

(For reference, standard Canopy uses 2-channel re-use with clusters of 6 APs on a tower with channel center spacing of either 25 MHz for Advantage APs or 20 MHz for non-Advantage APs. This is ABCABC channel planning, with 5 MHz guard band between the 20 MHz channels for Advantage APs and no guard band needed for non-Advantage.)

Available 5.4 GHz channel center frequencies for each region are shown in [Table 10](#). These vary by region due to

- different band edge RF specifications (for example, between Canada/US and Europe)
- requirements in US, Canada, Europe and Australia to not impinge on the frequencies between 5600 and 5650 MHz, which are frequencies on which some weather radar operate

Table 10: 5.4 GHz Channel Center Frequencies, by Region

Channel Bandwidth	Region(s)	Range of Center Frequencies Available (MHz)	Center Channel Spacing	# of center channels	# of non-overlapping channels
5MHz	United States, Canada and Australia	5475 – 5597.5 and 5652.5 – 5715	2.5MHz	76	38
	Europe	5472.5 – 5597.5 and 5652.5 – 5717.5	2.5MHz	78	40
	Brazil, India, Russia and Other	5475 – 5715	2.5MHz	97	49
10MHz	United States, Canada and Australia	5480 – 5595 and 5655 – 5710	5MHz	36	18
	Europe	5475 – 5595 and 5655 – 5715	5MHz	38	20
	Brazil, India, Russia and Other	5480 – 5710	5MHz	47	24
20MHz	United States, Canada and Australia	5475 – 5590 and 5660 – 5705	5MHz	34	9
	Europe	5470 – 5590 and 5660 – 5710	5MHz	36	9
	Brazil, India, Russia and Other	5475 – 5705	5MHz	47	12
20MHz FSK (for comparison)	United States, Canada, Europe and Australia	5495 – 5585 and 5665 – 5705	5MHz	28	8

Available 4.9 GHz channel center frequencies are shown in [Table 11](#).

Table 11: 4.9 GHz Channel Center Frequencies

Range of Center Frequencies Available (MHz) (on 5 MHz centers within this range, inclusive)	Number of center channels	Maximum number of non-overlapping channels
4945 - 4985	9	5

The best practice for channel planning for APs is to conduct extensive site RF surveys before choosing channels. The SM provides a basic Spectrum Analyzer that can be used for site surveys. For more sophisticated analysis, consider consulting an experienced RF engineer and using a full-featured spectrum analyzer.

3.2 DOWN TILT

The standard AP antenna produces a 3 db beam elevation (up and down) of 5°, with near-in null fill that allows good coverage of close-in SMs that otherwise would be affected by the narrow pattern. This is a narrower pattern than operators may be used to with standard Canopy's 60° 3 dB beam, and may require down tilt on the antenna. The bracket of the standard antenna has provision for measured down tilt. The recommended practice is to use one of the many radio analysis and mapping tools or on-line tools to calculate down tilt based on antenna height above the service area.

3.3 WEATHER RADAR

Spectrum between 5600 and 5650 MHz (sometimes called the “weather notch”) is used by some weather radar and is not allowed for use by regulations in some regions, including US, Canada and, for new equipment, Europe. When the Canopy module is set to either of those regions (configured on the Configuration => General page of the module), it will not allow configuration of the appropriate frequencies, as shown in [Table 10](#). Even in regions where use of the spectrum between 5600 and 5650 MHz is allowed, the best practice is to not use these channels if there are any other usable channels available. Only use the channels in this “weather notch” after monitoring the spectrum for a week or more using a spectrum analyzer to ascertain the spectrum is clear and there is no weather radar in the area that will cause interference to your Canopy system.

3.4 RANGE AND THROUGHPUT PLANNING

PMP 430 and PTP 230 5.4 and 5.8-GHz series modules provide 45+ Mbps aggregate throughput at distances of 1.2 miles (1.92 km) and 2.3 miles (3.68 km) respectively. PMP 400 and PTP 200 Series modules provide up to 21 Mbps aggregate throughput at distances of 1.4 miles (2.25 km) in RF environments with clear line-of-sight and low background interference levels. Additional performance details are shown in [Table 8](#) on page 32. RF environments with occluded Fresnel zones or higher background interference levels may give lower, but still very good, performance, depending on the specifics of the environment.

Similar to standard Canopy, at any given instant, any radios operating at 1X or 2X take more “air time” to transmit a given amount of data than if they were running at 3X. Similar to standard Canopy, PMP 400/430 and PTP 200/230 Series modules may see reduced total throughput when handling traffic with a high percentage of small packets.

The effect of this, again similar to standard Canopy, is that at any given instant total throughput depends on

- Mix of links running at 3X, 2X, and 1X
- Mix of packet sizes

3.5 SPECTRUM ANALYZER

A spectrum analyzer is available on the SM's Tools => Spectrum Analyzer page. The spectrum analyzer is also available on an AP by temporarily converting it to an SM by setting the **Device Type** to **SM** on the AP's Configuration => General page. The spectrum analyzer works like the spectrum analyzer in classic FSK SMs.

Spectrum analyzer uses include:

- Showing relative power levels (instantaneous and average) across the band, to aid in selecting channels and performing RF planning.
- Troubleshooting to finding the frequency, relative power level, and location of interferers by rotating a single SM, or triangulating from multiple SMs in a geographical area.

Release 10.2 added a configurable setting on the Tools => Spectrum Analyzer web page to display either instantaneous or averaging for spectrum analyzer results for the PTP 100 BHs and PMP 430 5.8-GHz Series. Release 10.3 added this enhancement for the PMP 400/430 5.4-GHz, PTP 200 BHs and PMP 100 Series.

The PMP 430 and PTP 230 Series uses average detector rather than peak detector algorithm which results in ~10 dBm lower readings than PMP 400 Series and FSK which use peak detectors. For example, when measuring power from an OFDM AP transmitting on a given channel the PMP 430 5.8-GHz OFDM SM might show a **Receive Power Level** of -60 dBm while a PMP 100 5.7-GHz FSK SM spectrum analyzer shows a power level of -53 for that channel.

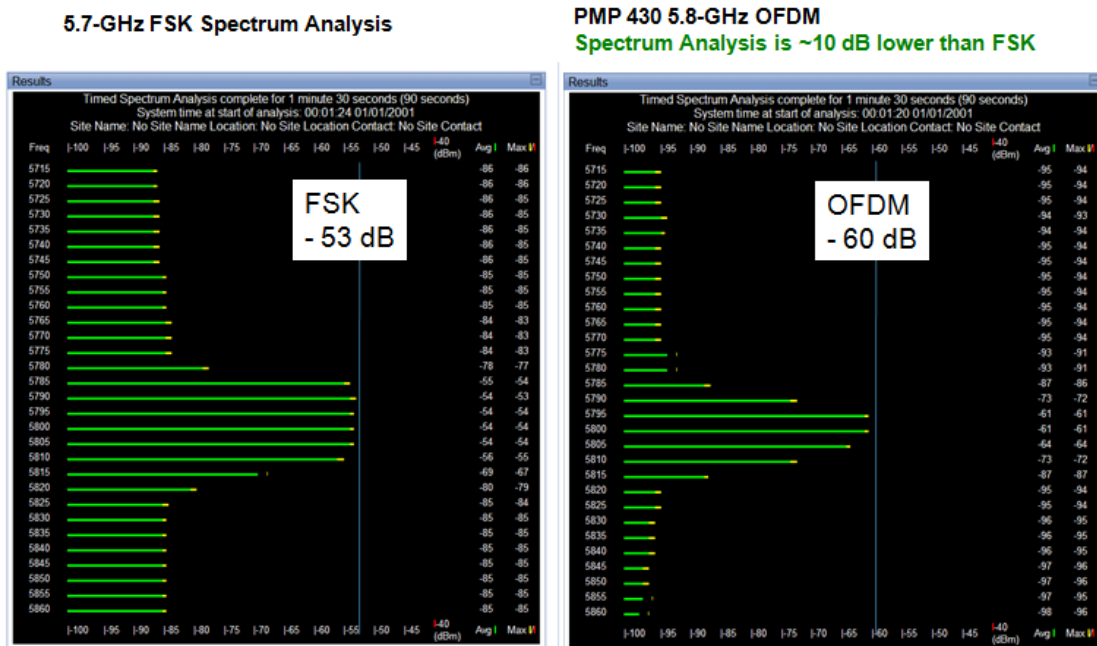

Figure 23: PMP 430 spectrum analysis compared to FSK

In addition, an PMP 430 SM measures power across 5, 10 or 20-MHz channels (PTP 230 measures power across 10 or 20-MHz channels) while an FSK SM measures power across 20-MHz channels, so power measurements are not directly comparable between the two. For both FSK and OFDM, the receiver's channel bandwidth has been added to the display. This is important to note as the width of the OFDM channel (5, 10 or 20MHz) affects the bandwidth data of the spectrum analyzer sample.

The built-in spectrum analyzer can be very useful as a tool for troubleshooting and RF planning, but doesn't duplicate the accuracy and programmability of a dedicated, high-end spectrum analyzer, which may be needed in some cases.

3.6 COLLOCATION OF 5.8 GHZ OFDM WITH STANDARD 5.7 GHZ CANOPY FSK

When locating 5.8 GHz PMP 430 OFDM APs near 5.7 GHz standard Canopy FSK APs (especially on the same tower, but also in the same geographical area), the following practices should be followed to avoid interference between the two systems:

- Plan spacing between OFDM and FSK channels to provide **25 MHz center spacing**, which gives a 10 MHz guard band between the 10 MHz OFDM channel and the 20 MHz FSK channel.
- **Coordinate** Downlink Data %, Range, and Control Slot settings using both the OFDM and the FSK **frame calculators**

The following paragraphs give more details on these recommended practices.

3.6.1 Channel Spacing

Center spacing of 25 MHz between collocated FSK and OFDM APs provides a 10 MHz guard band between the 20 MHz and 10 MHz channels, which has proven useful and needed in field testing. Alternatively, in cases where channel planning is severely restricted and the 10 MHz guard band (25 MHz spacing) is not possible, using vertical separation of 5 feet or more between the OFDM and FSK APs may allow collocation with no guard band (15 MHz spacing) in some deployments.

3.6.2 Frame Calculations and Configuration Settings

Interference between collocated Canopy systems can be avoided by following two practices:

1. Use a CMM with GPS synchronization. This synchronizes frame start, so that all collocated APs begin transmitting at the same time each 2.5 millisecond frame.
2. Use the frame calculators in each module, OFDM and FSK (the frame calculators are different, as frame details are different) to select Downlink Data %, Range, and Control Slots for each system that produce "Rec SEQ Start" values that are within 300 bit times. This ensures that all collocated APs end transmission each frame before any collocated AP begins to receive.

When collocating only Canopy OFDM APs together, or collocating only Canopy hardware-scheduled FSK APs together, the simple practice of setting the Downlink Data %, Range, and Control Slots the same on all APs ensures they won't interfere with each other. (These parameters are set on the "Configuration => Radio" page of the AP.) However, due to the different "physical" layer between Canopy OFDM and Canopy FSK, this doesn't necessarily work when collocating OFDM and FSK together.

You will need to use frame calculators on both the OFDM and FSK modules, as they are different frame calculators. For the same Downlink Data %, Range, and Control Slots, the frame calculators give different results. Use of the frame calculators is similar to the previous use when collocating PMP 100 FSK software-scheduled and hardware-scheduled APs.

3.7 COLLOCATION OF 5.4 GHZ OFDM WITH STANDARD 5.4 GHZ CANOPY FSK

When locating 5.4 GHz PMP 400/430 and PTP 200/230 Series OFDM APs near 5.4 GHz standard Canopy FSK APs (especially on the same tower, but also in the same geographical area), the following practices should be followed to avoid interference between the two systems:

- Plan spacing between OFDM and FSK channels to provide **25 MHz center spacing**, which gives a 10 MHz guard band between the 10 MHz OFDM channel and the 20 MHz FSK channel.
- **Coordinate** Downlink Data %, Range, and Control Slot settings using both the OFDM and the FSK **frame calculators**

The following paragraphs give more details on these recommended practices.

3.7.1 Channel Spacing

Center spacing of 25 MHz between collocated FSK and OFDM APs provides a 10 MHz guard band between the 20 MHz and 10 MHz channels, which has proven useful and needed in field testing. Alternatively, in cases where channel planning is severely restricted and the 10 MHz guard band (25 MHz spacing) is not possible, using vertical separation of 5 feet or more between the OFDM and FSK APs may allow collocation with no guard band (15 MHz spacing) in some deployments.

3.7.2 Frame Calculations and Configuration Settings

Interference between collocated Canopy systems can be avoided by following two practices:

3. Use a CMM with GPS synchronization. This synchronizes frame start, so that all collocated APs begin transmitting at the same time each 2.5 millisecond frame.
4. Use the frame calculators in each module, OFDM and FSK (the frame calculators are different, as frame details are different) to select Downlink Data %, Range, and Control Slots for each system that produce "Rec SEQ Start" values that are within 300 bit times. This ensures that all collocated APs end transmission each frame before any collocated AP begins to receive.

When collocating only Canopy OFDM APs together, or collocating only Canopy hardware-scheduled FSK APs together, the simple practice of setting the Downlink Data %, Range, and Control Slots the same on all APs ensures they won't interfere with each other. (These parameters are set on the "Configuration => Radio" page of the AP.) However, due to the different "physical" layer between Canopy OFDM and Canopy FSK, this doesn't necessarily work when collocating OFDM and FSK together.

You will need to use frame calculators on both the OFDM and FSK modules, as they are different frame calculators. For the same Downlink Data %, Range, and Control Slots, the frame calculators give different results. Use of the frame calculators is similar to the previous use when collocating PMP 100 FSK software-scheduled and hardware-scheduled APs.

Procedure 1: Finding collocation values using Frame Calculators

Using the “Tools => Frame Calculator” on an OFDM module, enter the desired Downlink Data %, Range, and Control Slot settings, click Calculate, and observe the “Rec SEQ Start” value.

Using the “Tools => Frame Calculator” on an FSK module, enter the desired Downlink Data %, Range, and Control Slot settings, click Calculate, and observe the “Rec SEQ Start” value.

Iterate, usually adjusting the FSK Downlink Data % and the OFDM Downlink Data % values by a few percent each time, until the “Rec SEQ Start” times of all collocated modules are within 300 bit times of each other.

Configure the OFDM modules using the resulting OFDM values, and the FSK modules using the resulting FSK values.

The frame calculator page (FSK and OFDM) has been simplified with Release 10.3 to show only information pertinent to co-location. It will now display AP TX end time and AP RX start time which allows the operator to more easily calculate co-location duty cycles.

Tools → OFDM Frame Calculator
5.7GHz OFDM - Access Point - 0a-00-3e-37-af-99

OFDM Frame Calculator Parameters	
Link Mode :	<input type="radio"/> Point-To-Point Link <input checked="" type="radio"/> Multipoint Link
Max Range :	5 Miles (Range: 1- 30 miles)
Air Delay :	0 bits
Cyclic Prefix :	One Quarter
Channel Bandwidth :	20.0 MHz
Platform Type AP/BHM :	P11
Platform Type SM/BHS :	P11
Downlink Data :	48 %
Control Slots :	2 (Range: 0—15)
<input type="button" value="Apply Settings"/> <input type="button" value="Calculate"/>	

Calculated Frame Results	
Total Frame Bits : 25000	
AP/BHM Details :	
Data Slots (Down/Up) : 34 +/37 +	
Round Trip Air Delay (MaxRange) : 540 bit	
Approximate distance (MaxRange) : 5.023 Miles	
AP Transmit End :	11269
AP Receive Start :	12081
AP Receive End :	24225
SM/BHS Details :	
SM Receive End :	11269
SM Transmit Start :	11811

Tools → Frame Calculator
5.7GHz - Access Point - 0a-00-3e-d5-b9-97

5.8-GHz OFDM
AP TX end time
and
AP RX start time

Frame Calculator Parameters	
Software Version Transmitter :	CANOPY7.2—Current
Software Version Receiver :	CANOPY7.2—Current
Link Mode :	<input type="radio"/> Point-To-Point Link <input checked="" type="radio"/> Multipoint Link
AES, 2X Rate, Encryption Enabled :	<input type="radio"/> True <input checked="" type="radio"/> False
Max Range :	5 Miles (Range: 1- 30 miles)
Platform Type AP/BHM :	P11
Platform Type SM/BHS :	P11
Frequency Band :	5.7GHz
Downlink Data :	48 %
Control Slots :	2 (Range: 0—15)
<input type="button" value="Apply Settings"/> <input type="button" value="Calculate"/>	

Calculated Frame Results	
Total Frame Bits : 25000	
AP/BHM Details :	
Data Slots (Down/Up) : 17 +/18 +	
Round Trip Air Delay (MaxRange) : 540 bit	
Approximate distance (MaxRange) : 5.023 Miles	
AP Transmit End :	11562
AP Receive Start :	12375
AP Receive End :	24879
SM/BHS Details :	
SM Receive End :	11563
SM Transmit Start :	12105

Tools → Frame Calculator
5.7GHz - Access Point - 0a-00-3e-d5-b9-97

5.7-GHz FSK
AP TX end time
and
AP RX start time

4 Configuring

Most PMP 400/430 Series and PTP 200/230 Series configuration items are identical or very similar to configuration items in standard FSK Canopy modules. This section discusses those that are new or changed and also remarks on some that remain unchanged.

4.1 LINK OPERATION – 1X/2X/3X

PMP 400/430 and PTP 200/230 Series products offer three levels or speeds of operation – 1X, 2X, and 3X. If received power is less due to distance between the AP/BHM and the SM/BHS or due to obstructions, or interference affects the RF environment, the Canopy system will automatically and dynamically adjust links to the best operation level. Distance, rates and other information associated with the operation levels are shown in [Table 8](#) on page 32.

The system chooses its operation rate dynamically, based on Canopy's internal ARQ (Automatic Repeat reQuest) error control method. With ARQ, every data slot of every frame sent over the air (except downlink broadcast) is expected to be acknowledged by the receiver, and if acknowledgement is not received, the data is resent. The sending unit monitors these resends, and adjusts the operation rate accordingly. A normal system may have links that move from 3X to 2X (or 1X) and back as the RF environment changes. Furthermore, the links operate independently; normal operation can have a downlink running at 3X while the uplink RF environment only supports 2X.

The default is for both AP/BHM and SM/BHS to be enabled for 3X operation. An operator may "lock down" a link to 1X/2X operation or to only 1X operation using the Dynamic Rate Adapt parameter on the SM's/BHS's Configuration => General page as shown in [Figure 24](#). This parameter locks down the uplink or downlink operation. An operator may lock down an entire sector to 2X and 1X operation, or to only 1 X operation, using the Dynamic Rate Adapt parameter on the AP's Configuration => General page. This parameter locks down uplink or downlink of all links in the sector, and overrides any SM 1X/2X/3X settings. For example, if an individual link is set for 3X operation at the SM and the sector is set for 1X operation at the AP, all links in the sector will be locked down to 1X operation.

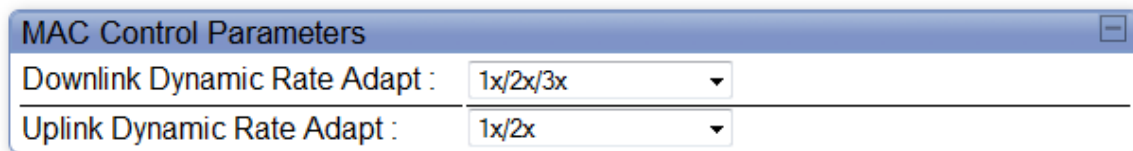

Figure 24: Dynamic Rate Adapt on AP "Configuration => General" page

In most cases an operator is well-served to leave the setting at 1X/2X/3X and let the system automatically and dynamically choose the best rate for each link. Cases when it may be useful to lock down a link to 1X or 2X include:

- If you are having trouble aiming a link or getting it to register, locking the link down to 2X or 1X may help in some cases.
- If the link is suspected to be oscillating between operation rates to the detriment of throughput, locking the link down may increase throughput. Usually, even if the link is moving rapidly between operation rates, overall link throughput and sector capacity are highest if the link is left at 3X and the link can choose its own rate dynamically.
- General link troubleshooting

Optimal sector utilization involves having as many links as possible running at 3X. This provides as much capacity as possible for the sector. As an example, you want to limit throughput to an individual subscriber to 1X rates. This *does not* mean you should set that link to 1X operation.

Use MIR (Maximum Information Rate) settings to cap the SM's bandwidth use, but let the link run at as high an operation rate as the RF environment will allow. This ensures that any transmission uses as little "air time" as possible, leaving more "air time" for other SMs.

4.2 TRANSMITTER OUTPUT POWER (AND NO JITTER)

The AP/BHM's Transmitter Output Power is configured on the AP/BHM's "Configuration => Radio" page.

Table 12: PMP 400/430 and PTP 200/230 Tx output power

Radio/ Frequency	Channel Size	Region(s)	Transmit Output Power Range	TX Default Setting	Antenna Gain (18 dBi – 1dB cable loss)	Max EIRP (Tx + Antenna Gain)
PMP 430 5.8 GHz OFDM	5 MHz	United States and Canada	-30 to +19 dBm	19 dBm	17 dBm	36 dBm
		Europe and India	-30 to +13 dBm	13 dBm	17 dBm	30 dBm
	10 MHz	United States and Canada	-30 to +19 dBm	19 dBm	17 dBm	36 dBm
		Europe and India	-30 to +16 dBm	16 dBm	17 dBm	33 dBm
	20 MHz	United States, Canada, Europe and India	-30 to +19 dBm	19 dBm	17 dBm	36 dBm
PMP 430 5.4 GHz OFDM	5 MHz	United States, Canada, Europe, India, Russia, Brazil and Australia	-30 to +7 dBm	7 dBm	17 dBm	24 dBm
	10 MHz		-30 to +10 dBm	10 dBm	17 dBm	27 dBm
	20 MHz		-30 to +13 dBm	13 dBm	17 dBm	30 dBm
PTP 230 5.8 GHz OFDM	10 MHz	United States and Canada	-30 to +19 dBm	19 dBm	17 dBm	36 dBm
		Europe and India	-30 to +16 dBm	16 dBm	17 dBm	33 dBm
	20 MHz	United States, Canada, Europe and India	-30 to +19 dBm	19 dBm	17 dBm	36 dBm
PTP 230 5.4 GHz OFDM	10 MHz	United States, Canada, Europe, India, Russia, Brazil and Australia	-30 to +7 dBm	7 dBm	17 dBm	24 dBm
			-30 to +10 dBm	10 dBm	17 dBm	27 dBm
	20 MHz		-30 to +13 dBm	13 dBm	17 dBm	30 dBm
PMP 400 PTP 200 5.4 GHz OFDM	10 MHz	United States, Canada, Europe, India, Russia, Brazil and Australia	-30 to +12 dBm	10 dBm	17 dBm	27 dBm
PMP 400 PTP 200 4.9 GHz OFDM	10 MHz	United States, Canada, Europe, India, Russia, Brazil and Australia	-30 to +18 dBm	18 dBm	17 dBm	35 dBm

For the PMP 400 5.4-GHz OFDM to meet 27 dBm EIRP with the connectorized 18 dBi antenna (with 1 dB of cable loss) that comes with the 5440AP or 5441AP, or the integrated 17 dBi antenna that comes with a 5440BH or 5441BH, the maximum setting allowed is **10 dBm** (the default) since 27-17=10.

If a connectorized AP or BHM has been purchased and the operator has provided the antenna, the Transmitter Output Power must be configured based on that antenna and consistent with local or regional regulations. For example, if a 5440APC is being used with a 15 dBi antenna, then the maximum setting allowed to meet 27 dBm EIRP is the full 12 dBm of which the radio is capable.

**IMPORTANT!**

It is the responsibility of the operator and professional installer to ensure Transmitter Output Power is set within regulatory limits for their country or region. These must be set or confirmed on initial configuration and after a module is reset to factory defaults, and should be confirmed after the software on a module is upgraded.

In most cases the operator will want to set the AP's Transmitter Output Power to the maximum allowed so as to have the greatest overall range and the greatest range for 3X operation. It may be useful to reduce Transmitter Output Power when Canopy systems are located close together, with good coverage given because of their proximity and full power isn't needed, or in cases where an operator is trying to reduce interference from the Canopy system to other systems.

Each SM's Transmitter Output Power is automatically set by the AP. The AP monitors the received power from each SM, and adjusts each SM's Transmitter Output Power so that the received power at the AP from that SM is not greater than -60 dBm. In addition, for 5.4-GHz SMs, the AP sets the SM's Transmitter output power so the SM's EIRP will be within regulatory requirements.

PMP 400/430 Series networks use Auto-TPC because OFDM technology is more sensitive to large differences in power levels from SMs operating at various distances from the AP than the single carrier technology used in Canopy FSK.

PTP 200 Series bridges do not use Auto-TPC – the operator sets Transmitter Output Power on the “Configuration => Radio” page of both the BHM and the BHS.

PMP 400/430 and PTP 200/230 Series modules display the typical Canopy “Receive Power Level” as shown in [Figure 25](#). Due to the different modulation technique no “jitter” is calculated or displayed.

General Status | **Session Status** | Remote Subscribers | Event Log | Network Interface | Layer 2 Neighbors

Home → Session Status

5.7GHz OFDM - Access Point - 0a-00-3e-3f-ff-13

Session Status Configuration

Show Idle Sessions : Enabled
 Disabled

Session Status List

[LUID: 002 - \[0a-00-3e-3f-fe-05\]](#) State: IN SESSION (Encrypt Disabled)

Site Name : No Site Name
 Software Version : CANOPY 10.0 (Build 14) Sep 21 2009
 Software Boot Version : CANOPYBOOT 1.0
 FPGA Version : 091709 (DES, Sched, US/ETSI) P11
 Session Timeout: 0, AirDelay 0 ns, 0 bits (approximately 0.000 miles (0 feet))
 Session Count: 1, Reg Count 1, Re-Reg Count 0, Session Uptime 01:42:35
Power Level (Avg/Last): -60 dB/-60 dB
 Sustained Uplink Data Rate (SM): 20000 (kbps)
 Uplink Burst Allocation (SM): 500000 (kbit)
 Sustained Downlink Data Rate (SM): 20000 (kbps)
 Downlink Burst Allocation (SM): 500000 (kbit)
 Low Priority Uplink CIR (SM): 0 (kbps) Low Priority Downlink CIR (SM): 0 (kbps)
 Rate : VC 18 Rate 3X/1X

Figure 25: SM Power Level on AP “Home => Session Status” page.

4.3 DOWNLINK DATA %, RANGE, AND CONTROL SLOTS

The **Downlink Data** parameter on the AP’s and BHM’s Configuration => General page can be set in 1% increments between 10% and 90%. The default as shown in [Figure 26](#) is 75%.

In order for U.S. model 5.4 GHz PTP Series radios to meet FCC DFS compliance, the **Downlink Data** has been limited to 10-65% at the Backhaul Master. For all other regions of 5.4 GHz PTP 230 Series radios and all regions of 5.8 GHz PTP radios, the **Downlink Data** range remains 10-90%.

The **Range** parameter on the AP’s Configuration => General page can be set in 1-mile increments between 1 and 30 miles for PMP 430 5 and 10MHz channel bandwidth and between 1 and 24 miles for PMP 430 20MHz channel bandwidth. The default as shown in [Figure 26](#) is 2 miles. Set the **Range** to the distance of the furthest SM from any AP in the area. The **Range** parameter effectively determines frame structure of the Canopy over-the-air protocol, especially turn-around guard time. Setting **Range** the same across a geographical area give best overall performance.

Range does not change transmit power levels. Do not set a higher **Range** than needed. A higher **Range** gives no higher power and slightly reduces throughput to allow for higher air delay and turn-around time.

If the **Range** is set to greater than 5 miles, the SM limits the **Downlink Data** to a maximum of 85% to avoid close-in SMs having registration issues. For example, a Range of 6 miles and a **Downlink Data** of 90% is not allowed. Operationally,

- if the Downlink Data % is set to greater than 85% and the user enters a range greater than 5 miles, the module will reset the Downlink Data % to 85%
- if the range is set to greater than 5 miles and the user enters a Downlink Data % of greater than 85%, the module will reset the Downlink Data % to 85%.

Configuration → Radio

5.4GHz OFDM - Access Point - 0a-00-3e-30-2e-0a

Radio Configuration	
Radio Frequency Carrier :	5490
Channel Bandwidth :	20.0 MHz
Cyclic Prefix :	One Sixteenth
Color Code :	4 (0—254)
Subscriber Color Code Rescan (When not on a Primary Color Code) :	0 Minutes (0 — 43200)
Subscriber Color Code Wait Period for Idle :	0 Minutes (0 — 60)
Sector ID :	0
Max Range :	2 Miles (Range: 1— 24 miles)
Downlink Data :	75 % (Range: 10 — 90 %)

Figure 26: Max Range & Downlink Data on AP "Configuration => Radio" page.

Suggested Control Slot settings as a function of number of SMs in the sector are shown in [Table 13](#). Generally all APs in a cluster should use the same number of control slots so as to keep the frame structures, and thereby the send and receive timing, the same.

Table 13: PMP 400/430 AP Control Slot Settings

Number of SMs that Register to the AP	Suggested Number of Control Slots
1 to 10	1 ¹ or 2
11 to 50	4
51 to 150	6
151 to 200	8

Note 1: Any OFDM sector with the **Hi Priority Channel** enabled on any SM should be configured with at least 1 **Control Slot** on the AP.

In some cases operators may find that sectors with high levels of small packet requests, such as might be seen in a sector handling several VoIP streams, benefit overall from slightly higher Control Slot settings. If different sectors require different numbers of Control Slots, the operator should use the Frame Calculator to find a combination of settings that put "Rec SEQ Start" times within 300 bit times. See section [3.7.2](#) on page [39](#) for details.

Control Slots are reserved for SMs' bandwidth requests and never handle data. A higher number of control slots gives higher probability that an SM's bandwidth request will be heard when the system is heavily loaded, but with the tradeoff that sector capacity is reduced by about 100 kbps for each Control Slot configured, so there will be less capacity to handle the request.

Uplink Data Slots are used first for data. If they are not needed for data in a given frame the data slot can be used by the SMs for bandwidth requests. This allows SMs in sectors with zero control slots configured to still make bandwidth requests using unused data slots.

Downlink Data %, Range, and Control Slots should be set consistent with the results of any collocation planning done using OFDM and FSK frame calculators in section [3.7.2](#) on page [39](#).

The BHM performs its own ranging and so no range need be set for it.

BHMs do not have settings for control slots, as there is no bandwidth request contention on the one-to-one link.

4.4 DFS AND REGULATORY PARAMETERS FOR 5.8 & 5.4 GHZ RADIOS

Dynamic Frequency Selection (DFS) is a requirement in several countries and regions for 5 GHz unlicensed systems to detect radar systems and avoid co-channel operation. DFS and other regulatory requirements drive the settings for the following parameters, as discussed in this section:

- Region Code
- Primary Frequency
- Alternate 1 and Alternate 2 Frequencies
- External Antenna Gain

On the AP/BHM, the “Home => DFS Status” page shows current DFS status of all three frequencies and a DFS log of past DFS events. Unlike standard Canopy, the PMP 400/430 and PTP 200/230 Series AP, SM, and BH do not offer “Whitening”, as the OFDM technology obviates the need for it.

Current DFS Status	
Primary RF Carrier Frequency :	Active, 5595 Mhz, Normal Transmit
Alternate RF Carrier Frequency 1 :	No Frequency Selected
Alternate RF Carrier Frequency 2 :	No Frequency Selected
DFS Detections :	0

DFS Event History	
Time: 00:00:01 UT: 01/01/2001:	Event: Channel Availability Check, Freq: 5595 MHz
Time: 00:01:03 UT: 01/01/2001:	Event: Start Transmit, Freq: 5595 MHz

Figure 27: DFS Status on AP "Home => DFS Status" page.

4.4.1 Background and Operation

The modules use region-specific DFS based on the “Region Code” selected on the module’s “Configuration => General” page. By directing installers and technicians to set the Region Code correctly, the operator gains confidence the module is operating according to national or regional regulations without having to deal with the details for each region.

Available “Region Codes” include Other, United States, Canada, Europe, Brazil, India, Russia, Indonesia and Australia. Operators in regions or countries not listed and with requirements aligned with one of the listed countries should set the Region Code to that country. Operators in regions or countries with no requirements for DFS should use the “Other” Region Code.

New APs and BHMs from the factory will show a Region Code of “None”, and will not transmit until the Region Code is set to a value other than “None”.

Canada, United States and Europe have requirements to avoid certain 5.4-GHz frequencies used by some weather radar. To meet this requirement, modules set to a Region Code of Canada, United States or Europe will display the center channel frequencies shown in [Table 10](#) on page [35](#) on the AP’s and BHM’s Carrier Frequency pop-up and on the SM’s and BHS’s Frequency Scan Selection List.

Table 14 shows the details of DFS operation and channels available for each Region Code, including whether DFS is active on the AP/BHM, SM/BHS, which DFS regulation apply, and any channel restrictions. DFS does not apply to 4.9 GHz.

Table 14: 5.4 / 5.8 GHz OFDM DFS Operation based on Region Code

Region Code ¹	Frequency	AP/BHM	SM/BHS	Weather Radar Notch-Out
United States	5.4 GHz	FCC/IC DFS ³	No effect	Yes
	5.8 GHz	No effect	No effect	No
Canada	5.4 GHz	FCC/IC DFS ³	No effect	Yes
	5.8 GHz	No effect	No effect	No
Europe	5.4 GHz	ETSI DFS ⁴	ETSI DFS	Yes
	5.8 GHz	ETSI DFS ⁵	ETSI DFS	No
Brazil	5.4 GHz	ETSI DFS	No effect	No
	5.8 GHz	No effect	No effect	No
Australia	5.4 GHz	FCC/IC DFS	No effect	Yes
	5.8 GHz	No effect	No effect	No
Russia	5.4 GHz	No effect	No effect	No
	5.8 GHz	No effect	No effect	No
India	5.4 GHz	No effect	No effect	No
	5.8 GHz	No effect	No effect	No
Other	5.4 GHz	No effect	No effect	No
	5.8 GHz	No effect	No effect	No

1. In all cases set the Region Code to the region you are in and the equipment will provide DFS consistent with that region's regulations. For countries or regions not listed, use a Region Code that provides DFS functionality and channels consistent with your country's regulatory requirements.
2. In some countries and regions, 5600 MHz to 5650 MHz is "notched" out to meet requirements to not transmit in weather radar frequencies.
3. FCC/IC indicates compliance with FCC Report and Order 03-287 and Industry Canada requirements.
4. ETSI DFS indicates compliance with ETSI EN 301 893 v1.4.1
5. ETSI DFS indicates compliance with ETSI EN 302 502 v1.2.1

After an AP or BHM with DFS boots it performs a channel availability check on its main carrier frequency for 1 minute, monitoring for the radar signature without transmitting. If no radar signature is detected during this minute, the module then proceeds to normal beacon transmit mode. If it does detect a radar signature, the frequency is marked for a 30 minute non-occupancy period, and the module moves to its 1st alternate carrier frequency. The AP/BHM continues this behavior through its 2nd alternate frequency if needed and then waits until the first frequency ends the 30 minute non-occupancy period. While operating, if the AP/BHM detects a weather

radar signature it marks the current carrier frequency for a 30 minute non-occupancy period and moves to check the next-in-line carrier frequency.

An SM/BHS does not begin transmission until it detects a beacon from an AP/BHM. If APs/BHMs are not transmitting, SMs/BHSs will be silent.

The FCC and IC require DFS only on APs/BHMs. Europe applies the ETSI specification to both APs/BHMs and SMs/BHSs, while Brazil applies it only to AP/BHMs. In the ETSI case, when an SM/BHS boots, it scans to find a Canopy beacon from a AP/BHM. If an AP/BHM is found, the SM/BHS performs a channel availability check on that frequency for 1 minute, monitoring for the radar signature, without transmitting. A DFS decision is made based on the following:

- If no radar pulse is detected during this 1 minute, the SM/BHS proceeds through normal steps to register to an AP/BHM.
- If the SM/BHS does detect radar, it locks out that frequency for 30 minutes and continues scanning other frequencies in its scan list.

Note, after an SM with DFS has seen a radar signature on a frequency and locked out that frequency, it may connect to a different AP if color codes, AP transmitting frequencies, and SM scanned frequencies support that connection.

BHSs would not be expected to connect to a different BHM, as backhaul links should be configured using color codes and authentication to ensure a BHS only connects with its intended BHM.

To simplify operation and ensure compliance, an SM/BHS takes on the DFS type of the AP/BHM to which it registers. For example, when an SM in Europe registers to an AP with the Region Code set to "Europe", that SM will use ETSI DFS, no matter what its Region Code is set to, even if its Region Code is set to "None". Note, the operator should still configure the Region Code in the SM correctly, as future releases may use the Region Code for additional region-specific options.

For all modules running DFS, the module displays its DFS state on its Home => General Status page as one of the following:

- `Checking Channel Availability Remaining time n seconds, where n counts down from 60 to 1.`
- `Normal Transmit`
- `Radar Detected Stop Transmitting for n minutes, where n counts down from 30 to 1.`
- `Idle`, only for SM/BHS, indicates module is scanning, but has not detected a beacon from an AP/BHM. Once it detects beacon, the SM/BHS begins a Channel Availability Check on that frequency.

4.4.2 Setting DFS and Regulatory Parameters

Setting the Region Code

All modules display a Region Code pop-up on the Configuration => General page as shown in [Figure 28](#) on page 50.

On new modules from the factory, or after resetting to factory defaults, the operator should set this Region Code consistent with their country or region. For countries or regions not listed in the Region Code pop-up, set the Region Code consistent with your country's regulatory

requirements. For example, several countries in South America follow the same DFS regulations as Brazil, so in those countries the Region Code should be set to “Brazil”.

**IMPORTANT!**

Operators under regulatory requirements for DFS must ensure the new Canopy parameter “Region Code” is set correctly. This applies to initial configuration, after a module is reset to factory defaults, or after a module is upgraded.

An AP or BHM will not transmit if the Region Code is configured to “None”.

**IMPORTANT!**

On APs or BHMs received from the factory, with Region Code set to “None”, the operator must set the Region Code before the module will transmit. The same is true of APs and BHMs which have been reset to factory defaults.

The screenshot displays the 'Configuration -> General' page for a 5.4GHz OFDM Access Point. The page is organized into several sections:

- Device Type:** Device Setting is set to AP (selected) and SM.
- Link Speeds:** Link Speed is set to Auto 100F/100H/10F/10H.
- Bandwidth Configuration Source:** Configuration Source is set to SM.
- Sync Setting:** Sync Input is set to Sync to Received Signal (Power Port).
- Regional Settings:** Region Code dropdown menu is open, showing options: None, Australia, Brazil, Canada (highlighted), Europe, India, Russia, United States, and Other.
- Web Page Configuration:** Webpage Auto Update is set to (0 = Disable Auto Update).
- Bridge Configuration:**
 - Bridge Entry Timeout: 25 Min
 - Translation Bridging: Disabled (selected)
 - Send Untranslated ARP: Disabled (selected)
 - SM Isolation: Disable SM Isolation

A 'Save Changes' button is located at the top of the configuration area. On the left, a navigation menu includes Home, Configuration, Statistics, Tools, Account, Quick Start, Copyright, and Logoff. The user's account information is shown as 'Account: admin Level: ADMINISTRATOR'.

Figure 28: Region Code on AP “Configuration => General” page

An SM/BHS has both a configurable **Region Code** and, once it registers to an AP or BHM, an active **Regional Code**. After an SM/BHS registers to an AP/BHM, it uses the region code of the AP/BHM to determine its DFS behavior and displays the AP/BHM’s region code on its Home => General Status page, as shown in [Figure 30](#).

The two **Region Codes** on an SM/BHS should be the same in normal operation. However, they will not be the same if, for example, an SM configured with a **Region Code** of “None” has registered to an AP with a **Region Code** of Europe as shown in [Figure 29](#) and [Figure 30](#).

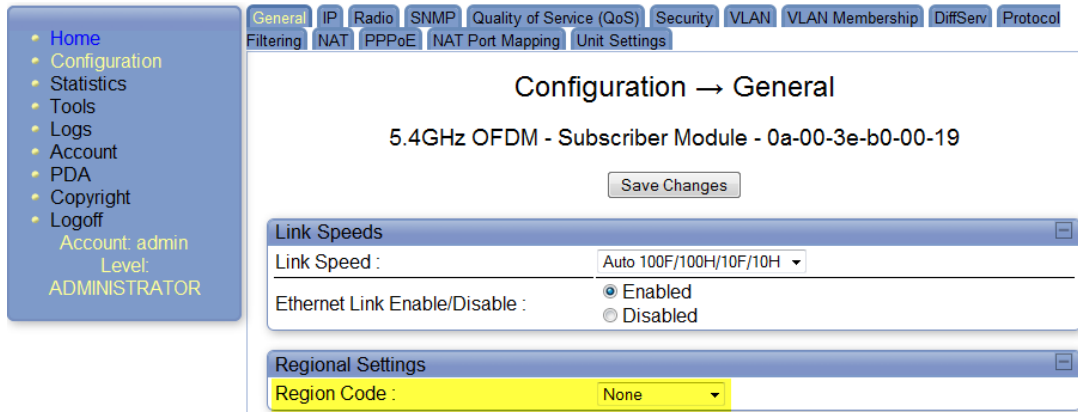

Figure 29: Configured Region Code on SM Configuration => General page

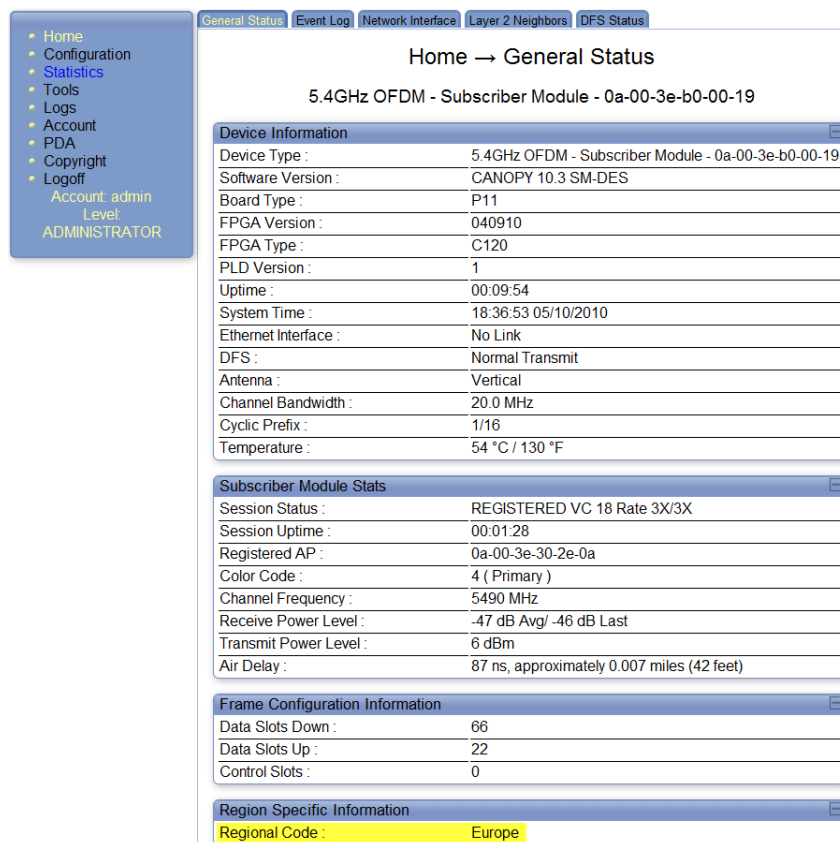

Figure 30: Active Region Code on SM Home => General Status page

The AP or BHM always operates under its manually configured Region Code (the one on the Configuration => General page), and so does not show a Region Code on its Home => General Status page.

Under normal operations, APs and BHMs operating with DFS (see Table 14) will experience an additional minute after power-up or reboot before they will register any SMs or BHSs. SMs and BHSs operating with DFS (see Table 14) will experience an additional minute after they reboot before they will register to an AP or BHM.

It takes two reboots to set the parameters described below on a module starting from factory defaults. Set the **Region Code** as described above, **Save Changes**, and **Reboot**. If the module

then invokes DFS (based on the region code and frequency band as shown in [Table 14](#)), the **Radio Frequency Carriers** and **External Antenna Gain** parameters will be displayed. Set them as described below, **Save Changes**, and **Reboot** again.

**IMPORTANT!**

Set the **Region Code**, **Save Changes**, and **Reboot** to see the context-sensitive DFS parameters. Unlike with many context-sensitive parameters, these do not appear in the GUI with only a **Save Changes**.

Setting Radio Frequencies

APs and BHMs running DFS include an option for setting up to two alternate frequencies on the “Configuration => Radio” page, in addition to the primary frequency. These alternate frequencies are used in the unlikely event radar is detected and the main frequency is locked out due to DFS detection. If these are left at “None”, no backup frequencies will be used in the case of DFS detection, and the AP or BHM will lock itself out from any transmission for 30 minutes.

If radar is detected on the main frequency, either at startup or during operation, a Channel Availability Check will be performed on the 1st alternate frequency before it is then used for transmission. If radar is detected on the 1st alternate frequency, either during Channel Availability Check or during operation, a Channel Availability Check will be performed on the 2nd alternate frequency before it is then used for transmission. If radar is detected on the 2nd alternate frequency, either during Channel Availability Check or during operation, the radio will cease transmission unless or until the primary channel clears its 30-minute lock-out.

The alternate frequencies configured in the AP/BHM must be included in the SM/BHS's Frequency Scan List, or the SMs/BHS can't follow their AP/BHM if it switches to a new channel. Additional frequencies may be checked in the Frequency Scan List depending on local practices, for example an operator may want to configure an SM to only register on certain frequencies to drive a known SM to AP mapping. Another example would be an operator who configures an SM to register on many frequencies so that it may find another AP to register to if its usual AP isn't available.

Note: use site surveys and RF planning to choose alternate frequencies useful for each sector, and consider testing on the alternate frequencies to ensure compatibility with the sector's RF environment.

4.5 EXTERNAL GAIN FIELD

An AP, SM, or BH needs to know the gain of its antenna to perform DFS and Auto-TPC (Automatic Transmit Power Control) (SM only) consistent with regional or national regulations. The GUI includes an **External Gain** field to support this.

Key points about the **External Gain** field include:

- **External Gain** is defined as the gain of the antenna minus the loss in the coaxial cable and connectors.
- The **External Gain** is set on the Configuration => Radio page of each module (AP, SM, BHM, or BHS)
- The default on a 5.4-GHz SM or a unit reset to factory defaults is **17 dB**.
- The default on a 5.8-GHz SM or a unit reset to factory default is **17 dB**
- The range is 0 to 35 dB.

- A 5.4-GHz SM or BH with an integrated antenna has an **External Gain** of 17 dB.
- The antenna sold with the connectorized 5.4 or 5.8 GHz AP has a gain of 18 dB and cable loss of approximately 1 dB, giving an **External Gain** of 17 dB.
- A 4.9 GHz SM or BH with an integrated antenna has an **External Gain** of 17 dB.
- The antenna sold with the connectorized 4.9 GHz AP has a gain of 18 dB and cable loss of approximately 1 dB, giving an **External Gain** of 17 dB.
- Any radio using DFS will use the **External Gain** to appropriately adjust sensitivity to radar signals. The use of DFS is determined by the **Region Code** setting on the Configuration => Home page.
- The Auto-TPC used by the PMP 400/430 and PTP 230 Series system takes into account the **External Gain** so as not to exceed national or regional EIRP limits.

Procedure for setting the External Gain

1. If using a BH or SM with an integrated antenna or a connectorized AP with the connectorized antenna sold with it, leave the **External Gain** on the Configuration => Radio page set to the factory default of 17 dB.

If using another antenna, set the **External Gain** to the gain of the antenna minus the loss in coaxial cable and connectors.



IMPORTANT!

Ensure the **External Gain** is set correctly. Setting it low or high can lead to either a system overly sensitive to DFS events or a system not transmitting at its full legal power.

4.6 NETWORK CONTROL PARAMETERS

Parameters for High Priority/DiffServ, NAT, DHCP, VLAN, MIR, and CIR are configured the same as they are in standard Canopy. The operator may (or may not) want to take advantage of the higher possible MIR to provide greater bandwidth to a given SM.

4.7 FORWARD ERROR CORRECTION

PMP 400/430 and PTP 200 Series radios use FEC (Forward Error Correction) to extend the range of the modules. They use Reed-Solomon error correction optimized at 3/4 coding. The coding rate is not settable by the operator.

4.8 CYCLIC PREFIX (CONFIGURABLE ONLY ON PTP 200/230 BH & PMP 430 AP/SM)

OFDM technology uses a cyclic prefix, where a portion of the end of a symbol (slot) is repeated at the beginning of the symbol (slot) to allow multi-pathing to settle before receiving the desired data. A 1/4 cyclic prefix means that for every 4 bits of throughput data transmitted, an additional bit is used, A 1/8 cyclic prefix means that for every 8 bit of throughput data transmitted, an additional bit is used.

PMP 400 Series networks use a cyclic prefix of 1/4 that is not configurable by the operator.

PMP 430 and PTP 230 Series networks use a default cyclic prefix of 1/4 that is configurable by the operator to 1/8 or 1/16. The Cyclic Prefix is set on the Configuration => Radio page on the AP. Changing the default from 1/4 to 1/8 can increase throughput by ~2 Mbps (assuming 75% duty cycle in PMP 430 networks) in installations with low multipath conditions. It is recommended to test 1/8 or 1/16 cyclic prefix to determine actual performance based on RF conditions.

PTP 200 Series modules (OFDM BHs) are settable for either 1/8 or 1/4 cyclic prefix. The use of 1/8 cyclic prefix provides about 11% higher maximum throughput, and is recommended for backhaul operations in most cases.

- The **Cyclic Prefix** is set on the Configuration => Radio page of the BHM.
- The default on a new unit or when the unit is reset to factory defaults is **1/4 Cyclic Prefix**.
- In most deployments, **1/8 or 1/16 Cyclic Prefix** will provide a high quality, higher throughput link. In cases with severe multi-pathing or obstructions, **1/4 Cyclic Prefix** may give better overall results.

Procedure for setting the Cyclic Prefix

Set the **Cyclic Prefix** on the Configuration => Radio page of both the BHM and the BHS to **1/8** before deployment.



IMPORTANT!

The **Cyclic Prefix** must be set the same on both the BHM and the BHS. If they don't match, the BHS will not register to the BHM.

During installation use Link Tests to confirm link quality per standard installation and alignment procedures.

If a Link Test shows low throughput or efficiency, consider changing the Cyclic Prefix to **1/4** on *both* the BHM and the BHS along with other standard installation troubleshooting procedures such as re-aiming, off-axis aiming, changing location, raising or lowering the height of the radio, adjusting **Transmission Power** up or down, or identifying and mitigating sources of interference.

5 Installation



WARNING!

Installing a unit usually involves height, electricity, and exposure to RF (Radio Frequency) energy. To avoid personal injury, follow applicable national and local safety regulations along with industry best practices. Also follow the specific guidelines in this document, including Exposure Separation Distances in section 6.3 on page 71.

5.1 INSTALLING AN AP WITH CONNECTORIZED ANTENNA

This section addresses installation aspects specific to the PMP 400/430 and PTP 200 Series AP. General communications equipment, infrastructure, and facilities site design should be performed in line with Motorola's "Standards and Guidelines for Communications Sites" (also known as the R56 manual). The R56 manual is available in either CD soft copy (part no. 9880384V83) or three-ring bound color hard copy (6881089E50). Both may be purchased from Motorola Customer Care Services (1-800-814-0601).

These procedures are specific to the case of an AP purchased as a kit consisting of a connectorized antenna and a connectorized radio. They are also generally applicable to connectorized APs, SMs, or BHs when the antenna is purchased separately by the operator.

A short coaxial cable from the radio terminates in a male N connector. The antenna has a chassis-mounted female N connector. The antenna includes tower mount brackets with adjustable down-tilt.

Installing an AP typically consists of four phases:

5. Configuring the AP at an operator's facility or at the installation site using the information and settings defined previously in Planning (Section 3) and Configuring (Section 4).
6. Assembling the AP (radio and antenna and brackets) and physically installing it using Procedure 2 for 5.8 and 5.4 GHz APs or Procedure 3 for 4.9 GHz APs, along with physically installing a CMMmicro (for PMP 54400 AP only) or CMM4 (for either PMP 58430, 54430, 54400 or PMP 49400).
7. Cabling the AP to the CMMmicro (for PMP 54400 AP only) or CMM4 (for either PMP 58430, 54430, 54400 or PMP 49400), and grounding it to Protective Earth – PE using Procedure 4. This phase can also include cabling to backhauls, or running terrestrial feeds.
8. Confirming operation, using SMs in the field.

Local practices and choices of installation options will dictate the actual processes. For example, variations on these generalized procedures can be used to install on a building or install multiple APs on a pipe mount before hoisting up a tower for final attachment.

Procedure 2: Assembling a 5.8 or 5.4 GHz AP, and attaching to tower

1. Perform a parts check to ensure all parts are present.



2. Assemble the upper bracket, per the diagram that comes with the antenna.



3. Connect the radio to the antenna by sliding it into the captive space. Secure the radio to the antenna using the two bolts provided.



4. Assemble the lower bracket on the antenna assembly. Although it may seem intuitive to attach both brackets to the tower or pole and then hang the antenna, it usually works better to have the bottom bracket already attached to the antenna before climbing.
5. Weatherproof the connector with waterproof wrap.



6. Use standard work and safety practices for tower climbing. Connect the upper bracket to a pole, mounting fixture, or the tower.



7. Hang the antenna assembly on the upper bracket.



8. Connect the lower bracket to the pole or tower using the quick-connect system provided



9. The quick-connect system allows easy attachment, detachment, and adjustment without any loose parts.



10. Adjust down tilt per calculations done during Planning. Confirm down tilt after the radio is operational using SMs in the field at selected test locations.



Procedure 3: Assembling a 4.9 GHz AP, and attaching to tower

1. Perform a parts check to ensure all parts are present.

2. Assemble unit per the instructions that come with the kit.



3. Connect the radio to the antenna by sliding it into the captive space. Secure the radio to the antenna using the two bolts provided.



4. Connect coax N-connector

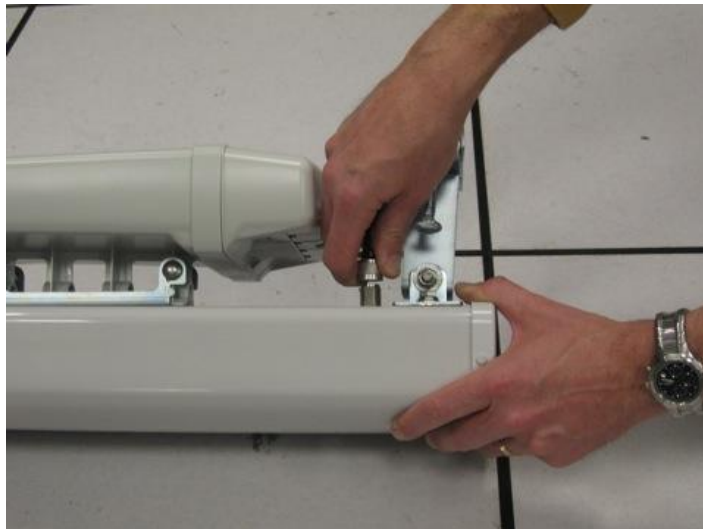

5. Use standard work and safety practices for tower climbing, and connect the upper assembly to a pole, mounting fixture, or the tower.

6. Adjust down tilt per previous calculations done during Planning. Confirm down tilt after the radio is operational using SMs in the field at selected test locations.



Procedure 4: Cabling and Grounding/Earthing the AP

1. Standard Canopy installation practices apply, including using shielded Ethernet cable for all infrastructure cabling, using drip loops, providing extra cable for future use at any termination, and ensuring the tower or structure is fully grounded (Protective Earth – PE).
2. Use dielectric grease (which is uniformly non-conducting) on all connections and in all RJ-45 Ethernet connectors. The best practice is to use enough grease to fill the RJ-45 female connector, and then insert the RJ-45 male connector and push the grease further into the Canopy unit and around the RJ-45 connector. Excess grease can be wiped over the connector area to provide some resistance to water ingress around the connector.
3. Use a 600SS surge suppressor within 3 ft (~1 m) of the AP and ground it to known good ground (Protective Earth - PE) on the tower or support structure with a 10 AWG ground strap.
4. A pole mount kit is available for mounting the 600SS to the tower or mast. The mount includes a termination point for the ground strap from the 600SS.
5. Run a 10 AWG ground strap from the ground lug on the AP (see [Figure 31](#)) to known good ground (Protective Earth - PE) to complete the grounding and protection of the AP. The termination point on the 600SS pole mount kit may be used for this.

**Figure 31: Ground lug highlighted on AP**

The PMP 400/430 AP and PTP 200 Series BH have metal-to-metal contact from the tower or support structure, through the antenna, through the coax cable, to the radio. Installing surge suppression at the AP is strongly recommended to provide the best protection from near lightning hits.

Install a 600SS surge suppressor within 3 ft (~1 m) of an AP or BH. A pole mount kit for the 600SS is shown in [Figure 16](#) to facilitate installation of the 600SS by the AP or BH.

Up to four 600SS surge suppressors may be mounted in series on an Ethernet link without degrading the link. The equivalent of a 600SS is built into each of the 8 ports on a CMM4 and counts as one of the four. The CMMmicro uses a different protection scheme and does not have the equivalent of a 600SS on each port.

As an example, a typical installation might have properly-grounded 600SS units within 3 ft of each AP and additional properly-grounded 600SS units on each Ethernet cable mounted outside at the point of cable entry to a telecommunications hut that contains the CMM4.

5.2 INSTALLING AN SM OR BH WITH AN INTEGRATED ANTENNA

Installing an SM or BH with an integrated antenna is very similar to installing standard Canopy SMs as described in the *Motorola PMP Solutions User Guide*, with the differences outlined below.

Use an SMMB2 SM mounting bracket for the PMP 54400 and 49400 SM and a SMMB1 mounting bracket for the PMP 58430/54430 SM and PTP 58230/54230 BH. The PMP 400 Series SM or the PTP 200 Series BH is heavier and has a higher wind load than a classic Canopy module, and so the stronger SMMB2 is required. The SMMB2 is the mounting arm used with Canopy 900 MHz integrated APs and SMs, and used with reflectors.

Use dielectric grease (which is uniformly non-conducting) on all connections and in all RJ-45 Ethernet connectors. The best practice is to use enough grease to fill the RJ-45 female connector, and then insert the RJ-45 male connector and push the grease further into the Canopy unit and around the RJ-45 connector. Excess grease can be wiped over the connector area to provide some resistance to water ingress around the connector.

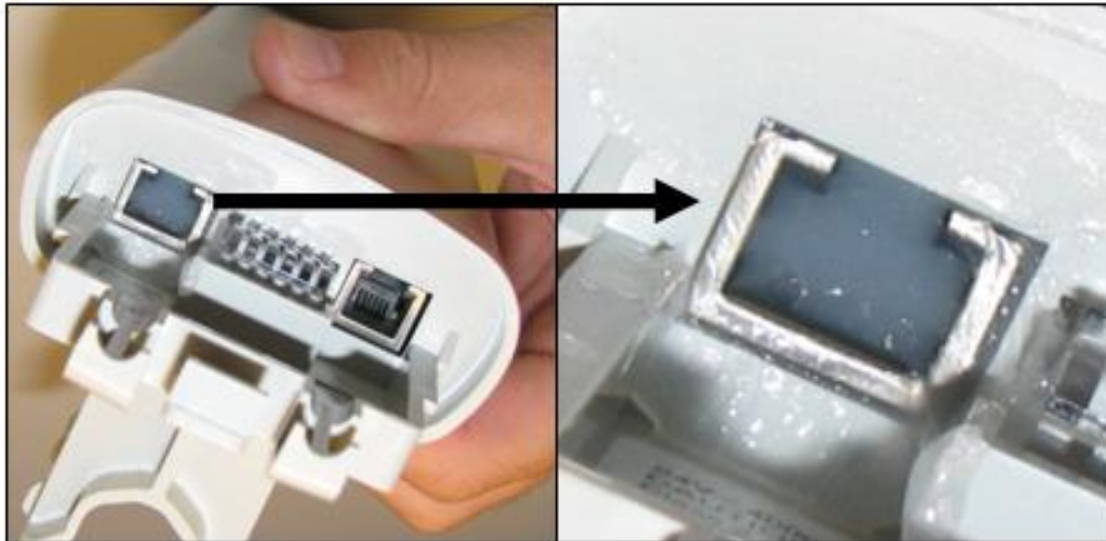

Figure 32: Dielectric Grease – Apply to RJ45 connector

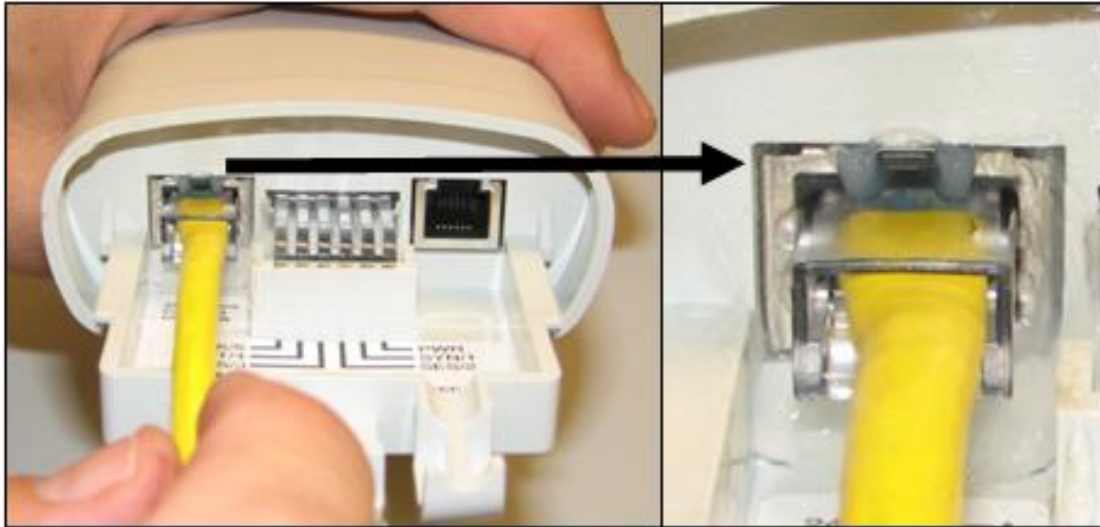

Figure 33: Dielectric Grease - Insert Ethernet Cable

The PMP 400 SM and PTP 200 BH have a ground/Protective Earth lug, just like the AP. Although not as critical as in the case of the AP (where there is metal-to-metal connectivity through the coax and antenna to ground), the lug can be used to ground the SM or BH for additional protection. In addition, a 600SS can be used within 3 ft (1 m) of the SM or BH to provide additional protection. Especially for a BH, or in cases where the SM is mounted high and is more exposed, or in known difficult areas for lightning, consider using these two techniques to increase the radio's resistance to lightning.

In all cases where Ethernet cables penetrate a building, home, or telecommunications hut, mount a properly-grounded 600SS outside at the point of Ethernet cable building entry to protect persons and property in the building.

PMP 400/430 and PTP 200/230 Series modules do not display a jitter value. Use **Receive Power Level** for aiming and then use Link Tests to confirm alignment.

The **Receive Power Level** is a relative, not absolute, value. The **Receive Power Level** on a module is useful during installation to aid in aiming where relative values over a short period of time are of interest. The displayed **Receive Power Level** is not designed to be highly accurate over time. The displayed **Receive Power Level** will vary with board-level temperature and may vary from module to module even if the actual received power is not varying. Know the limitations and use caution and judgment for any other use of **Receive Power Level**. Caution is advised when using **Receive Power Level** for monitoring a link over time, deciding if the link is within operating margins, deciding if a link is serviceable (link tests give a much better indication), or comparing the link to other links.

The alignment headset will play a tone that varies in pitch (received power level), but not volume (jitter), since PMP 400/430 and PTP 200/230 Series modules don't calculate a jitter.

6 Regulatory and Legal Notices

6.1 IMPORTANT NOTE ON MODIFICATIONS

Intentional or unintentional changes or modifications to the equipment must not be made unless under the express consent of the party responsible for compliance. Any such modifications could void the user's authority to operate the equipment and will void the manufacturer's warranty.

6.2 NATIONAL AND REGIONAL REGULATORY NOTICES

6.2.1 U.S. Federal Communication Commission (FCC) Notification

For 5.4-GHz and 5.8-GHz devices:

This device complies with Part 15 of the US FCC Rules and Regulations. Operation is subject to the following two conditions: (1) This device may not cause harmful interference, and (2) This device must accept any interference received, including interference that may cause undesired operation.

This equipment has been tested and found to comply with the limits for a Class B digital device, pursuant to Part 15 of the US FCC Rules. These limits are designed to provide reasonable protection against harmful interference in a residential installation. This equipment generates, uses, and can radiate radio-frequency energy and, if not installed and used in accordance with these instructions, may cause harmful interference to radio communications. If this equipment does cause harmful interference to radio or television reception, which can be determined by turning the equipment on and off, the user is encouraged to correct the interference by one or more of the following measures:

- Increase the separation between the affected equipment and the unit;
- Connect the affected equipment to a power outlet on a different circuit from that which the receiver is connected to;
- Consult the dealer and/or experienced radio/TV technician for help.

For 4.9-GHz devices:

The 4.9-GHz band is a licensed band allocated to public safety services. State and local government entities that provide public safety services are eligible to apply for 4.9 GHz licenses. For additional information, refer to FCC regulations.

FCC IDs and the specific configurations covered are listed in [Table 15](#).

Table 15: US FCC IDs and Industry Canada Certification Numbers and Covered Configurations

FCC ID	Industry Canada Cert Number	Frequencies	Module Families	Antenna	Maximum Tx Output Power
ABZ89FT7634	---	5 MHz channels, centered on 5727.5-5845 in 5 MHz increments (within the 5725-5850 MHz ISM band)	5780APC	17 dBi connectorized PCTEL Model 8514724E01 antenna (60° x 5° -3 dB beam width) with 1 dB connector cable loss	19 dBm
		10 MHz channels, centered on 5730-5845 in 5 MHz increments (within the 5725-5850 MHz ISM band)			
		20 MHz channels, centered on 5735-5840 in 5 MHz increments (within the 5725-5850 MHz ISM band)			
ABZ89FT7635	109W-5790	5 MHz channels, centered on 5727.5-5845 in 5 MHz increments (within the 5725-5850 MHz ISM band)	5790SM	10 dBi (55° x 55° and 3 dB beam width)	19 dBm
		10 MHz channels, centered on 5730-5845 in 5 MHz increments (within the 5725-5850 MHz ISM band)			
		20 MHz channels, centered on 5735-5840 in 5 MHz increments (within the 5725-5850 MHz ISM band)			
		10 MHz channels, centered on 5730-5845 in 5 MHz increments (within the 5725-5850 MHz ISM band)	5780 BH 5781 BH	10 dBi (55° x 55° and 3 dB beam width)	19 dBm
		20 MHz channels, centered on 5735-5840 in 5 MHz increments (within the 5725-5850 MHz ISM band)			

ABZ89FT7637	109W-5480	10 MHz channels, centered on 5480-5595 and 5655-5710 MHz in 5 MHz increments (within the 5470-5725 MHz U-NII band with 5600-5650 MHz excluded)	5480 APC	17 dBi connectorized PCTEL Model 8514724E01 antenna (60° x 5° -3 dB beam width) with 1 dB connector cable loss	10 dBm
		20 MHz channels, centered on 5485-5590 and 5660-5705 MHz in 5 MHz increments (within the 5470-5725 MHz U-NII band with 5600-5650 MHz excluded)			13 dBm
ABZ89FT7638	109W-5490	10 MHz channels, centered on 5480-5595 and 5655-5710 MHz in 5 MHz increments (within the 5470-5725 MHz U-NII band with 5600-5650 MHz excluded)	5490 SM 5480 BH 5481 BH	10 dBi (55° x 55° -3 dB beam width)	17 dBm
		20 MHz channels, centered on 5485-5590 and 5660-5705 MHz in 5 MHz increments (within the 5470-5725 MHz U-NII band with 5600-5650 MHz excluded)			19 dBm
---	109W-5780	5 MHz channels, centered on 5727.5-5845 in 5 MHz increments (within the 5725-5850 MHz ISM band)	5780APC	17 dBi connectorized PCTEL Model 8514724E01 antenna (60° x 5° -3 dB beam width) with 1 dB connector cable loss	19 dBm
		10 MHz channels, centered on 5730-5845 in 5 MHz increments (within the 5725-5850 MHz ISM band)			
		20 MHz channels, centered on 5735-5840 in 5 MHz increments (within the 5725-5850 MHz ISM band)			
---	109W-5790	5 MHz channels, centered on 5727.5-5845 in 5 MHz increments (within the 5725-5850 MHz ISM band)	5790SM	10 dBi (55° x 55° and 3 dB beam width)	19 dBm

		10 MHz channels, centered on 5730-5845 in 5 MHz increments (within the 5725-5850 MHz ISM band)			
		20 MHz channels, centered on 5735-5840 in 5 MHz increments (within the 5725-5850 MHz ISM band)			
ABZ89FT7629	---	10 MHz channels, centered on 5480-5595 and 5655-5710 MHz in 5 MHz increments (within the 5470-5725 MHz U-NII band)	5440 AP	18 dBi connectorized PCTEL Model 8514724E01 antenna (60° x 5° -3 dB beam width) with 1 dB connector cable loss	10 dBm
			5440 SM 5440 BH	17 dBi integrated antenna (15° x 15° -3 dB beam width)	10 dBm
---	109W-5440	10 MHz channels, centered on 5480-5595 and 5655-5710 MHz in 5 MHz increments (within the 5470-5725 MHz U-NII band with 5600-5650 MHz excluded)	5440 AP	18 dBi connectorized PCTEL Model 8514724E01 antenna (60° x 5° -3 dB beam width) with 1 dB connector cable loss	10 dBm
			5440 SM 5440 BH	17 dBi integrated antenna (15° x 15° -3 dB beam width)	10 dBm
ABZ89FT7631	109W-4940	10 MHz channels, centered on 4945-4985 in 5 MHz increments (within the 4940-4990 MHz public safety licensed band)	4940 AP	18 dBi connectorized PCTEL Model AP 85010066001 antenna (60° x 5° -3 dB beam width) with 1 dB cable loss	18 dBm
			4940 SM 4940 BH	17 dBi integrated antenna (15.5° x 17.5° (el x az) -3 dB beam width)	18 dBm
<p>Note 1: To ensure regulatory compliance, including DFS compliance, the professional installer is responsible for:</p> <ul style="list-style-type: none"> • setting the Region Code on the Configuration => General page to the correct region • setting the Transmitter Output Power on the Configuration => Radio page no higher than listed for a given configuration • setting the External Gain on the Configuration => Radio page, if displayed, to the gain of any external device (such as a reflector or lens) 					

6.2.2 Industry Canada (IC) Notification

For 5.4 and 5.8-GHz devices:

This device complies with RSS-210 of Industry Canada. Operation is subject to the following two conditions: (1) This device may not cause harmful interference, and (2) This device must accept any interference received, including interference that may cause undesired operation.

Users should be cautioned to take note that in Canada high power radars are allocated as primary users (meaning they have priority) of 5650 – 5850 MHz and these radars could cause interference and/or damage to license-exempt local area networks (LELAN).

This equipment has been tested and found to comply with the limits for a Class B digital device, pursuant to RSS-210 of Industry Canada. These limits are designed to provide reasonable protection against harmful interference in a residential installation. This equipment generates, uses, and can radiate radio-frequency energy and, if not installed and used in accordance with these instructions, may cause harmful interference to radio communications. If this equipment does cause harmful interference to radio or television reception, which can be determined by turning the equipment on and off, the user is encouraged to correct the interference by one or more of the following measures:

- Increase the separation between the affected equipment and the unit;
- Connect the affected equipment to a power outlet on a different circuit from that which the receiver is connected to;
- Consult the dealer and/or experienced radio/TV technician for help.

To reduce potential radio interference to other users, the antenna type and its gain should be chosen so its Equivalent Isotropic Radiated Power (EIRP) is not more than that permitted for successful communication.

Industry Canada Certification Numbers and the specific configurations covered are listed in [Table 15](#).

This device has been designed to operate with the antennas listed in [Table 15](#) and having a maximum gain as shown in [Table 15](#). Antennas not included in [Table 15](#) or having a gain greater than as shown in [Table 15](#) are strictly prohibited from use with this device. Required antenna impedance is 50 ohms.

For 4.9-GHz devices:

The 4.9-GHz band is a licensed band allocated to public safety services. State and local government entities that provide public safety services are eligible to apply for 4.9 GHz licenses. For additional information, refer to Industry Canada regulations.

6.2.3 Regulatory Requirements for CEPT Member States (www.cept.org)

When operated in accordance with the instructions for use, Motorola Canopy Wireless equipment operating in the 5.4 GHz bands is compliant with CEPT Recommendation 70-03 Annex 3 for Wideband Data Transmission and HIPERLANs. For compliant operation in the 5.4 GHz band, the transmit power (EIRP) from the integrated antenna or a connectorized antenna shall be no more than 0.5 W (27 dBm).

For EU member states, RLAN equipment in the 5.4GHz bands is exempt from individual licensing under Commission Recommendation 2003/203/EC. Contact the appropriate national administrations for details on the conditions of use for the bands in question and any exceptions that might apply. Also see www.ero.dk for further information.

10 MHz channels are used, centered on 5475 to 5595 and 5655 to 5715 in 5 MHz increments. This is within the 5470 to 5725 MHz U-NII band with 5600 to 5650 MHz excluded.

Motorola Canopy Radio equipment operating in the 5470 to 5725 MHz band are categorized as “Class 1” devices within the EU in accordance with ECC DEC(04)08 and are “CE” marked  to show compliance with the European Radio & Telecommunications Terminal Equipment (R&TTE) directive 1999/5/EC. The relevant Declaration of Conformity can be found at <http://motorola.wirelessbroadbandsupport.com/doc.php>.

A European Commission decision, implemented by Member States on 31 October 2005, makes the frequency band 5470-5725 MHz available in all EU Member States for wireless access systems. Under this decision, the designation of Canopy 5.4GHz products become “Class 1

devices” and these do not require notification under article 6, section 4 of the R&TTE Directive.

Consequently, these 5.4GHz products are only marked with the  symbol and may be used in any member state.

For further details, see

http://europa.eu.int/information_society/policy/radio_spectrum/ref_documents/index_en.htm

6.2.4 European Union Notification for 5.8 GHz Product

The 5.7 and 5.8 GHz connectorized product is a two-way radio transceiver suitable for use in Broadband Wireless Access System (WAS), Radio Local Area Network (RLAN), or Fixed Wireless Access (FWA) systems. It is a Class 2 device and uses operating frequencies that are not harmonized throughout the EU member states. The operator is responsible for obtaining any national licenses required to operate this product and these must be obtained before using the product in any particular country.

This equipment is marked  to show compliance with the European R&TTE directive 1999/5/EC.

The relevant Declaration of Conformity can be found at

<http://motorola.wirelessbroadbandsupport.com/doc.php>.

6.2.5 Equipment Disposal



**Waste (Disposal)
of Electronic
and Electric
Equipment**

Please do not dispose of Electronic and Electric Equipment or Electronic and Electric Accessories with your household waste. In some countries or regions, collection systems have been set up to handle waste of electrical and electronic equipment. In European Union countries, please contact your local equipment supplier representative or service center for information about the waste collection system in your country.

6.2.6 EU Declaration of Conformity for RoHS Compliance

Motorola hereby declares that these Motorola products are in compliance with the essential requirements and other relevant provisions of Directive 2002/95/EC, Restriction of the use of certain Hazardous Substances (RoHS) in electrical and electronic equipment.

The relevant Declaration of Conformity can be found at

<http://motorola.wirelessbroadbandsupport.com/doc.php>.

6.2.7 UK Notification

The 5.8 GHz connectorized product has been notified for operation in the UK, and when operated in accordance with instructions for use it is compliant with UK Interface Requirement IR2007. For UK use, installations must conform to the requirements of IR2007 in terms of EIRP spectral density against elevation profile above the local horizon in order to protect Fixed Satellite Services. The frequency range 5795-5815 MHz is assigned to Road Transport & Traffic Telematics (RTTT) in the U.K. and shall not be used by FWA systems in order to protect RTTT devices. UK licensing specifies that radiolocation services shall be protected by a Dynamic Frequency Selection (DFS) mechanism to prevent co-channel operation in the presence of radar signals.

6.2.8 Luxembourg Notification

5.4GHz products can only be used for mobile services.

6.2.9 Czech Republic Notification

5.4 GHz products can be operated in accordance with the Czech General License No. GL-30/R/2000.

6.2.10 Greece Notification

The outdoor use of 5470-5725MHz is under license of EETT but is being harmonized according to the CEPT Decision ECC/DEC/(04) 08, of 9th July. End users are advised to contact the EETT to determine the latest position and obtain any appropriate licenses.

6.2.11 Brazil Notification

Brazil regulatory authorities have not approved these devices for operation in Brazil. Until they are approved, they are not available for sale in Brazil, and the information in this section is provisional and preliminary.

For compliant operation in the 5.4 GHz band, the Equivalent Isotropic Radiated Power from the integrated antenna or connectorized antenna shall not exceed 27 dBm (0.5 W).

The operator is responsible for enabling the DFS feature on any Canopy 5.4 GHz radio by setting the Region Code to "Brazil", including after the module is reset to factory defaults.

Important Note: This equipment operates as a secondary application, so it has no rights against harmful interference, even if generated by similar equipment, and cannot cause harmful interference on systems operating as primary applications.

6.2.12 Labeling and Disclosure Table for China

The People's Republic of China requires that Motorola's products comply with China Management Methods (CMM) environmental regulations. (China Management Methods refers to the regulation *Management Methods for Controlling Pollution by Electronic Information Products*.) Two items are used to demonstrate compliance; the label and the disclosure table.

The label is placed in a customer visible position on the product.

- Logo 1 means that the product contains no substances in excess of the maximum concentration value for materials identified in the China Management Methods regulation.
- Logo 2 means that the product may contain substances in excess of the maximum concentration value for materials identified in the China Management Methods regulation, and has an Environmental Friendly Use Period (EFUP) in years, fifty years in the example shown.

Logo 1



Logo 2



The Environmental Friendly Use Period (EFUP) is the period (in years) during which the Toxic and Hazardous Substances (T&HS) contained in the Electronic Information Product (EIP) will not leak or mutate causing environmental pollution or bodily injury from the use of the EIP. The EFUP indicated by the Logo 2 label applies to a product and all its parts. Certain field-replaceable parts, such as battery modules, can have a different EFUP and are marked separately.

The Disclosure Table (see [Table 16](#)) is intended only to communicate compliance with China requirements; it is not intended to communicate compliance with EU RoHS or any other environmental requirements.

Table 16: Disclosure Table

部件名称	有毒有害物质或元素					
	铅 (Pb)	汞 (Hg)	镉 (Cd)	六价铬 (Cr ⁶⁺)	多溴联苯 (PBB)	多溴二苯醚 (PBDE)
金属部件	x	o	x	x	o	o
电路模块	x	o	x	x	o	o
电缆及电缆组件	x	o	x	x	o	o
塑料和聚合物部件	o	o	o	o	o	x

o : 表示该有毒有害物质在该部件所有均质材料中的含量均在SJ/T11363-2006 标准规定的限量要求以下。

x : 表示该有毒有害物质至少在该部件的某一均质材料中的含量超出SJ/T11363-2006 标准规定的限量要求。

6.3 EXPOSURE SEPARATION DISTANCES

To protect from overexposure to RF energy, install Canopy radios so as to provide and maintain the minimum separation distances from all persons shown in [Table 17](#).

Table 17: Exposure Separation Distances

Module Type	Separation Distance from Persons
PMP 400/430 AP or SM or PTP 200/230 BH	At least 20 cm (approx 8 in)
PMP 430 SM or PTP 230 with Reflector Dish	At least 1.5 m (approx 5 ft)
PMP 430 SM or PTP 230 with LENS	At least 50 cm (approx 20 in)
Canopy Module (for comparison)	At least 20 cm (approx 8 in)

Section [6.3.1](#) and [Table 18](#) give details and discussion of the associated calculations.

6.3.1 Details of Exposure Separation Distances Calculations and Power Compliance Margins

Limits and guidelines for RF exposure come from:

- US FCC limits for the general population. See the FCC web site at <http://www.fcc.gov>, and the policies, guidelines, and requirements in Part 1 of Title 47 of the Code of Federal Regulations, as well as the guidelines and suggestions for evaluating compliance in FCC OET Bulletin 65.

- Health Canada limits for the general population. See Safety Code 6 on the Health Canada web site at <http://www.hc-sc.gc.ca/>.
- ICNIRP (International Commission on Non-Ionizing Radiation Protection) guidelines for the general public. See the ICNIRP web site at <http://www.icnirp.de/> and Guidelines for Limiting Exposure to Time-Varying Electric, Magnetic, and Electromagnetic Fields.

The applicable power density exposure limits from the documents referenced above are

- 10 W/m² for RF energy in the 5.4-GHz frequency bands.

Peak power density in the far field of a radio frequency point source is calculated as follows:

$$S = \frac{P \cdot G}{4 \pi d^2}$$

where
 S = power density in W/m²
 P = RMS transmit power capability of the radio, in W
 G = total Tx gain as a factor, converted from dB
 d = distance from point source, in m

$$d = \sqrt{\frac{P \cdot G}{4 \pi S}}$$

Rearranging terms to solve for distance yields

Table 18 shows calculated minimum separation distances *d*, recommended distances and resulting power compliance margins for each frequency band and antenna combination.

Table 18: Calculated Exposure Distances and Power Compliance Margins

Frequency Band	Antenna	Variable			<i>d</i> (calculated)	Recommended Separation Distance	Power Compliance Margin
		<i>P</i>	<i>G</i>	<i>S</i>			
5.4 / 5.8 GHz OFDM	Integrated, 10 dBi	0.079 W (19 dBm)	10 (10 dB)	10 W/m ² or 1 mW/cm ²	8 cm	20 cm (8 in)	6.3
	Connectorized, 17 dBi	0.05 W (10 dBm)	50 (17 dB)	10 W/m ² or 1 mW/cm ²	6 cm	20 cm (8 in)	10
4.9 GHz OFDM	Integrated, 10 dBi	0.079 W (19 dBm)	10 (10 dB)	10 W/m ² or 1 mW/cm ²	8 cm	20 cm (8 in)	6.3
	Connectorized, 17 dBi	0.063 W (18 dBm)	40 (16 dB)	10 W/m ² or 1 mW/cm ²	14 cm	20 cm (8 in)	2

The “Recommended Distances” are chosen to give significant compliance margin in all cases. They are also chosen so that an OFDM module has the same exposure distance as a Canopy module, to simplify communicating and heeding exposure distances in the field.

These are conservative distances:

- They are along the beam direction (the direction of greatest energy). Exposure to the sides and back of the module will be significantly less.
- They meet sustained exposure limits for the general population (not just short term occupational exposure limits), with considerable margin.
- The calculated compliance distance d is overestimated because the far-field equation models the antenna as a point source and neglects the physical dimension of the antenna.

6.4 LEGAL NOTICES

6.4.1 Software License Terms and Conditions

ONLY OPEN THE PACKAGE, OR USE THE SOFTWARE AND RELATED PRODUCT IF YOU ACCEPT THE TERMS OF THIS LICENSE. BY BREAKING THE SEAL ON THIS DISK KIT / CDROM, OR IF YOU USE THE SOFTWARE OR RELATED PRODUCT, YOU ACCEPT THE TERMS OF THIS LICENSE AGREEMENT. IF YOU DO NOT AGREE TO THESE TERMS, DO NOT USE THE SOFTWARE OR RELATED PRODUCT; INSTEAD, RETURN THE SOFTWARE TO PLACE OF PURCHASE FOR A FULL REFUND. THE FOLLOWING AGREEMENT IS A LEGAL AGREEMENT BETWEEN YOU (EITHER AN INDIVIDUAL OR ENTITY), AND MOTOROLA, INC. (FOR ITSELF AND ITS LICENSORS). THE RIGHT TO USE THIS PRODUCT IS LICENSED ONLY ON THE CONDITION THAT YOU AGREE TO THE FOLLOWING TERMS.

Now, therefore, in consideration of the promises and mutual obligations contained herein, and for other good and valuable consideration, the receipt and sufficiency of which are hereby mutually acknowledged, you and Motorola agree as follows:

Grant of License. Subject to the following terms and conditions, Motorola, Inc., grants to you a personal, revocable, non-assignable, non-transferable, non-exclusive and limited license to use on a single piece of equipment only one copy of the software contained on this disk (which may have been pre-loaded on the equipment)(Software). You may make two copies of the Software, but only for backup, archival, or disaster recovery purposes. On any copy you make of the Software, you must reproduce and include the copyright and other proprietary rights notice contained on the copy we have furnished you of the Software.

Ownership. Motorola (or its supplier) retains all title, ownership and intellectual property rights to the Software and any copies, including translations, compilations, derivative works (including images) partial copies and portions of updated works. The Software is Motorola's (or its supplier's) confidential proprietary information. This Software License Agreement does not convey to you any interest in or to the Software, but only a limited right of use. You agree not to disclose it or make it available to anyone without Motorola's written authorization. You will exercise no less than reasonable care to protect the Software from unauthorized disclosure. You agree not to disassemble, decompile or reverse engineer, or create derivative works of the Software, except and only to the extent that such activity is expressly permitted by applicable law.

Termination. This License is effective until terminated. This License will terminate immediately without notice from Motorola or judicial resolution if you fail to comply with any provision of this License. Upon such termination you must destroy the Software, all accompanying written

materials and all copies thereof, and the sections entitled Limited Warranty, Limitation of Remedies and Damages, and General will survive any termination.

Limited Warranty. Motorola warrants for a period of ninety (90) days from Motorola's or its customer's shipment of the Software to you that (i) the disk(s) on which the Software is recorded will be free from defects in materials and workmanship under normal use and (ii) the Software, under normal use, will perform substantially in accordance with Motorola's published specifications for that release level of the Software. The written materials are provided "AS IS" and without warranty of any kind. Motorola's entire liability and your sole and exclusive remedy for any breach of the foregoing limited warranty will be, at Motorola's option, replacement of the disk(s), provision of downloadable patch or replacement code, or refund of the unused portion of your bargained for contractual benefit up to the amount paid for this Software License.

THIS LIMITED WARRANTY IS THE ONLY WARRANTY PROVIDED BY MOTOROLA, AND MOTOROLA AND ITS LICENSORS EXPRESSLY DISCLAIM ALL OTHER WARRANTIES, EITHER EXPRESS OF IMPLIED, INCLUDING BUT NOT LIMITED TO IMPLIED WARRANTIES OF MERCHANTABILITY AND FITNESS FOR A PARTICULAR PURPOSE AND NONINFRINGEMENT. MOTOROLA DOES NOT WARRANT THAT THE OPERATION OF THE SOFTWARE WILL BE UNINTERRUPTED OR ERROR-FREE, OR THAT DEFECTS IN THE SOFTWARE WILL BE CORRECTED. NO ORAL OR WRITTEN REPRESENTATIONS MADE BY MOTOROLA OR AN AGENT THEREOF SHALL CREATE A WARRANTY OR IN ANY WAY INCREASE THE SCOPE OF THIS WARRANTY. MOTOROLA DOES NOT WARRANT ANY SOFTWARE THAT HAS BEEN OPERATED IN EXCESS OF SPECIFICATIONS, DAMAGED, MISUSED, NEGLECTED, OR IMPROPERLY INSTALLED. BECAUSE SOME JURISDICTIONS DO NOT ALLOW THE EXCLUSION OR LIMITATION OF IMPLIED WARRANTIES, THE ABOVE LIMITATIONS MAY NOT APPLY TO YOU.

Limitation of Remedies and Damages. Regardless of whether any remedy set forth herein fails of its essential purpose, IN NO EVENT SHALL MOTOROLA OR ANY OF THE LICENSORS, DIRECTORS, OFFICERS, EMPLOYEES OR AFFILIATES OF THE FOREGOING BE LIABLE TO YOU FOR ANY CONSEQUENTIAL, INCIDENTAL, INDIRECT, SPECIAL OR SIMILAR DAMAGES WHATSOEVER (including, without limitation, damages for loss of business profits, business interruption, loss of business information and the like), whether foreseeable or unforeseeable, arising out of the use or inability to use the Software or accompanying written materials, regardless of the basis of the claim and even if Motorola or a Motorola representative has been advised of the possibility of such damage. Motorola's liability to you for direct damages for any cause whatsoever, regardless of the basis of the form of the action, will be limited to the price paid for the Software that caused the damages. THIS LIMITATION WILL NOT APPLY IN CASE OF PERSONAL INJURY ONLY WHERE AND TO THE EXTENT THAT APPLICABLE LAW REQUIRES SUCH LIABILITY. BECAUSE SOME JURISDICTIONS DO NOT ALLOW THE EXCLUSION OR LIMITATION OF LIABILITY FOR CONSEQUENTIAL OR INCIDENTAL DAMAGES, THE ABOVE LIMITATION MAY NOT APPLY TO YOU.

Maintenance and Support. Motorola shall not be responsible for maintenance or support of the software. By accepting the license granted under this agreement, you agree that Motorola will be under no obligation to provide any support, maintenance or service in connection with the Software or any application developed by you. Any maintenance and support of the Related Product will be provided under the terms of the agreement for the Related Product.

Transfer. In the case of software designed to operate on Motorola equipment, you may not transfer the Software to another party except: (1) if you are an end-user, when you are transferring the Software together with the Motorola equipment on which it operates; or 2) if you are a Motorola licensed distributor, when you are transferring the Software either together with such Motorola equipment or are transferring the Software as a licensed duly paid for upgrade, update, patch, new release, enhancement or replacement of a prior version of the Software. If you are a Motorola licensed distributor, when you are transferring the Software as permitted herein, you agree to transfer the Software with a license agreement having terms and conditions

no less restrictive than those contained herein. You may transfer all other Software, not otherwise having an agreed restriction on transfer, to another party. However, all such transfers of Software are strictly subject to the conditions precedent that the other party agrees to accept the terms and conditions of this License, and you destroy any copy of the Software you do not transfer to that party. You may not sublicense or otherwise transfer, rent or lease the Software without our written consent. You may not transfer the Software in violation of any laws, regulations, export controls or economic sanctions imposed by the US Government.

Right to Audit. Motorola shall have the right to audit annually, upon reasonable advance notice and during normal business hours, your records and accounts to determine compliance with the terms of this Agreement.

Export Controls. You specifically acknowledge that the software may be subject to United States and other country export control laws. You shall comply strictly with all requirements of all applicable export control laws and regulations with respect to all such software and materials.

US Government Users. If you are a US Government user, then the Software is provided with "RESTRICTED RIGHTS" as set forth in subparagraphs (c)(1) and (2) of the Commercial Computer Software-Restricted Rights clause at FAR 52 227-19 or subparagraph (c)(1)(ii) of the Rights in Technical Data and Computer Software clause at DFARS 252.227-7013, as applicable.

Disputes. You and Motorola hereby agree that any dispute, controversy or claim, except for any dispute, controversy or claim involving intellectual property, prior to initiation of any formal legal process, will be submitted for non-binding mediation, prior to initiation of any formal legal process. Cost of mediation will be shared equally. Nothing in this Section will prevent either party from resorting to judicial proceedings, if (i) good faith efforts to resolve the dispute under these procedures have been unsuccessful, (ii) the dispute, claim or controversy involves intellectual property, or (iii) interim relief from a court is necessary to prevent serious and irreparable injury to that party or to others.

General. Illinois law governs this license. The terms of this license are supplemental to any written agreement executed by both parties regarding this subject and the Software Motorola is to license you under it, and supersedes all previous oral or written communications between us regarding the subject except for such executed agreement. It may not be modified or waived except in writing and signed by an officer or other authorized representative of each party. If any provision is held invalid, all other provisions shall remain valid, unless such invalidity would frustrate the purpose of our agreement. The failure of either party to enforce any rights granted hereunder or to take action against the other party in the event of any breach hereunder shall not be deemed a waiver by that party as to subsequent enforcement of rights or subsequent action in the event of future breaches.

6.4.2 Hardware Warranty in US

Motorola US offers a warranty covering a period of 1 year from the date of purchase by the customer. If a product is found defective during the warranty period, Motorola will repair or replace the product with the same or a similar model, which may be a reconditioned unit, without charge for parts or labor.

6.5 LIMIT OF LIABILITY

IN NO EVENT SHALL MOTOROLA BE LIABLE TO YOU OR ANY OTHER PARTY FOR ANY DIRECT, INDIRECT, GENERAL, SPECIAL, INCIDENTAL, CONSEQUENTIAL, EXEMPLARY OR OTHER DAMAGE ARISING OUT OF THE USE OR INABILITY TO USE THE PRODUCT (INCLUDING, WITHOUT LIMITATION, DAMAGES FOR LOSS OF BUSINESS PROFITS, BUSINESS INTERRUPTION, LOSS OF BUSINESS INFORMATION OR ANY OTHER PECUNIARY LOSS, OR FROM ANY BREACH OF WARRANTY, EVEN IF MOTOROLA HAS BEEN ADVISED OF THE POSSIBILITY OF SUCH DAMAGES. (Some states do not allow the

exclusion or limitation of incidental or consequential damages, so the above exclusion or limitation may not apply to you.) IN NO CASE SHALL MOTOROLA'S LIABILITY EXCEED THE AMOUNT YOU PAID FOR THE PRODUCT.