



**MOTOROLA**

**PDR 3500**  
**Portable Repeater**

**Basic Service Manual**

# Table of Contents

<b>1 - Foreword</b> .....	<b>1-1</b>
General .....	1-1
Safety Information .....	1-1
Manual Revisions .....	1-1
Computer Software Copyrights .....	1-1
Replacement Parts Ordering .....	1-1
Parts Ordering .....	1-2
Motorola Parts .....	1-2
Parts Identification .....	1-2
Related Documents .....	1-2
<b>2 - Safety Information</b> .....	<b>2-1</b>
General .....	2-1
Safe and Efficient Operation of Motorola Two-way Radios .....	2-1
RF Operational Characteristics .....	2-1
Exposure to Radio Frequency Energy .....	2-1
Electromagnetic Interference/Compatibility .....	2-2
Facilities .....	2-2
Aircraft .....	2-2
Medical Devices .....	2-2
Operational Warnings .....	2-3
Operational Cautions .....	2-3
Mobile Radio Operation and EME Exposure .....	2-3
Antenna Installation .....	2-4
<b>3 - Introduction</b> .....	<b>3-1</b>
General .....	3-1
Compact Mechanical Design .....	3-1
State-of-the-Art Electrical Design .....	3-1
Transmitter Circuitry .....	3-1
Receiver Circuitry .....	3-1
Station Control Module .....	3-1
Wireline Circuitry .....	3-2
Switching Power Supply .....	3-2
Standard Features .....	3-2
Optional Hardware Features .....	3-2
<b>4 - System Applications</b> .....	<b>4-1</b>
Local Control .....	4-1
Two Antenna Operation .....	4-1
External Duplexer Operation .....	4-2
Repeater RA or Cross Band Repeater Operation .....	4-2
<b>5 - Models and Specifications</b> .....	<b>5-1</b>
Model Chart .....	5-1
Maintenance Specifications .....	5-2
<b>6 - Approved Accessories</b> .....	<b>6-1</b>
General .....	6-1
Antenna .....	6-1

Ⓜ, Motorola, ASTRO, ASTRO CAI, and SECURENET are trademarks of Motorola, Inc.

© 2000 Motorola

Commercial, Government, Industrial Solutions Sector  
8000 W. Sunrise Blvd., Fort Lauderdale, FL 33322  
All Rights Reserved. Printed in U. S. A. 8/2000.

<b>7 - Setup and Connections</b> .....	<b>7-1</b>
Programming with RSS .....	7-1
Introduction .....	7-1
Connecting PC to	
PDR 3500 RSS Port .....	7-1
Using the RSS .....	7-2
Hardware Configuration .....	7-2
Alignment .....	7-2
Channel Information .....	7-4
Electrical Connections .....	7-5
Power Supply Connections .....	7-5
RF Cabling Connections .....	7-5
Introduction .....	7-5
Separate RX and TX Connectors .....	7-6
Duplexer .....	7-6
<b>8 - Operation</b> .....	<b>8-1</b>
Description .....	8-1
Summary of Switches, Pushbuttons, and Connectors .....	8-1
Summary of LED Indicators .....	8-1
<b>9 - Troubleshooting</b> .....	<b>9-1</b>
Introduction .....	9-1
Troubleshooting Overview .....	9-1
Recommended Test Equipment .....	9-1
Test Equipment List .....	9-1
Troubleshooting Procedures .....	9-1
Troubleshooting Overview .....	9-2
Introduction .....	9-2
Procedure 1: Routine Maintenance Functional Checkout .....	9-2
Procedure 2: Troubleshooting A Reported/Suspected Problem .....	9-2
How to Use These Troubleshooting Procedures .....	9-2
Interpreting LED Indicators .....	9-6
Interpreting Alarm Alert Tones .....	9-10
Introduction .....	9-10
Verifying Transmitter Circuitry .....	9-11
Required Test Equipment .....	9-11
Verifying Transmitter Circuitry Procedure .....	9-11
Verifying Receiver Circuitry .....	9-15
Required Test Equipment .....	9-15
Verifying Receiver Circuitry Procedure .....	9-16
Verifying Receiver Circuitry (Digital-Capable Stations) .....	9-21
Required Test Equipment .....	9-22
Wiring Diagram .....	9-23
Module Replacement Procedures .....	9-25
General Replacement Information .....	9-25
Anti-Static Precaution .....	9-25
Care of Gold-Plated Connector Contacts .....	9-26
Power Down Station Before Removing/Inserting Modules .....	9-26
Validating Repairs .....	9-26
Module Replacement .....	9-26
Station Control .....	9-27
Physical Replacement of the Station Control Module .....	9-27
After Installing the New Station Control Module .....	9-27
Wireline .....	9-28
Physical Replacement of the Wireline Module .....	9-28
After Installing the New Wireline Module .....	9-29
ASTRO Modem Card/V.24 Interface Card .....	9-29
Physical Replacement of the Card .....	9-29
After Installing the New Card .....	9-29
Receiver .....	9-29

Physical Replacement of the Receiver Module . . . . .	9-29
After Installing the New Receiver Module . . . . .	9-30
Exciter . . . . .	9-31
Frequency Band Considerations . . . . .	9-31
Physical Replacement of the Exciter Module . . . . .	9-31
After Installing the New Exciter Module . . . . .	9-31
Power Amplifier . . . . .	9-32
Frequency Band Considerations . . . . .	9-32
Physical Replacement of the Power Amplifier . . . . .	9-32
After Installing the New Power Amplifier . . . . .	9-33
Power Supply . . . . .	9-33
Physical Replacement of the Power Supply . . . . .	9-33
Backplane . . . . .	9-34
Before Installing the New Backplane . . . . .	9-34
Physical Replacement of the Backplane . . . . .	9-34
After Installing the New Power Amplifier . . . . .	9-35
Preselector Field Tuning Procedure . . . . .	9-35
Required Test Equipment . . . . .	9-36
VHF Tuning Procedure . . . . .	9-36
Calculating Proper Alignment Frequency . . . . .	9-36
Preparing Equipment . . . . .	9-37
VHF Tuning Procedure . . . . .	9-38
UHF Tuning Procedure . . . . .	9-39
Calculating Proper Alignment Frequency . . . . .	9-39
Preparing Equipment . . . . .	9-40
Tuning Procedure . . . . .	9-41

**10 - Functional Theory of Operation . . . . . 10-1**

Transmitter Circuitry Operation . . . . .	10-1
Introduction . . . . .	10-1
Exciter Module Operation . . . . .	10-1
Power Amplifier Module Operation . . . . .	10-2
Receiver Circuitry . . . . .	10-2
Introduction . . . . .	10-2
Receiver Module Operation . . . . .	10-2
Station Control Module . . . . .	10-3
Introduction . . . . .	10-3
Station Control Module Operation . . . . .	10-3
Wireline Interface Board . . . . .	10-3
Introduction . . . . .	10-3
Wireline Interface Board Operation . . . . .	10-3
Power Supply Module Operation . . . . .	10-4

**11 - Block Diagram, Schematics, Electrical Parts List, and Circuit Board Detail 11-1**

# List of Tables

Table 1: Rated Power and Distance . . . . .	2-4
Table 2: Model Structure. . . . .	5-1
Table 3: Options . . . . .	5-2
Table 4: Specifications . . . . .	5-2
Table 5: Specifications, continued . . . . .	5-3
Table 6: Switches, Pushbuttons, and Connectors . . . . .	8-1
Table 7: Summary of LED Indicators . . . . .	8-1
Table 8: Switches, Pushbuttons, and LED Indicators . . . . .	8-2
Table 9: PDR 3500 Station LED Indicator Functions . . . . .	9-6
Table 10: Motherboard DIP Switch Settings . . . . .	9-34

# List of Figures

Figure 1. EIA-232 Wiring Diagram . . . . .	7-1
Figure 2. Switches , Pushbuttons , Connectors, and LED Indicators for PDR 3500 . . . . .	8-2
Figure 3. PDR 3500 Station Troubleshooting Overview (Procedure 1: Routine Maintenance). . . . .	9-3
Figure 4. PDR 3500 Station Troubleshooting Overview (Procedure 2: Reported or Suspected Problem) . . . . .	9-4
Figure 5. PDR 3500 LED Indicators and Front Panel Buttons and Connectors . . . . .	9-9
Figure 6. Test Equipment Setup for Verifying Transmitter Circuitry. . . . .	9-12
Figure 7. Test Equipment Setup for Verifying Receiver Circuitry . . . . .	9-17
Figure 8A. Coupled receiver connection. (Top) B. Coupled duplexer connection. (Bottom) . . . . .	9-19
Figure 9. Disabling the Transmitter . . . . .	9-20
Figure 10. Interconnect Diagram . . . . .	9-24
Figure 11. Chassis Ground Wiring Diagram . . . . .	9-25
Figure 12. Test Equipment Setup for Preselector Field Tuning . . . . .	9-38
Figure 13. Location of Tuning Screws and Cavity Probe Holes. . . . .	9-39
Figure 14. Test Equipment Setup for Preselector Field Tuning . . . . .	9-41
Figure 15. Location of Tuning Screws and Cavity Probe Holes. . . . .	9-42
Figure 16. PDR 3500 Functional Block Diagram. . . . .	11-2
Figure 17. PDR 3500 Schematic Sheet 1 . . . . .	11-3
Figure 18. PDR 3500 Schematic Sheet 2 . . . . .	11-4
Figure 19. PDR 3500 Backplane Circuit Board Detail . . . . .	11-6

# Foreword

# 1

---

## General

The information contained in this manual supplement relates to all PDR 3500 stations, unless otherwise specified. This manual provides sufficient information to enable service shop personnel to troubleshoot and repair a PDR 3500 to the module level.

---

## Safety Information

Before operating a PDR 3500 station, please read the “Safety Information” section in the front of this manual.

---

## Manual Revisions

Changes which occur after this manual is printed are described in “FMRs.” These FMRs provide complete information on changes, including pertinent parts list data.

---

## Computer Software Copyrights

The Motorola products described in this manual may include copyrighted Motorola computer programs stored in semiconductor memories or other media. Laws in the United States and other countries preserve for Motorola certain exclusive rights for copyrighted computer programs, including the exclusive right to copy or reproduce in any form the copyrighted computer program. Accordingly, any copyrighted Motorola computer programs contained in the Motorola products described in this manual may not be copied or reproduced in any manner without the express written permission of Motorola. Furthermore, the purchase of Motorola products shall not be deemed to grant either directly or by implication, estoppel, or otherwise, any license under the copyrights, patents or patent applications of Motorola, except for the normal non-exclusive royalty free license to use that arises by operation of law in the sale of a product.

---

## Replacement Parts Ordering

When ordering replacement parts or equipment information, the complete identification number should be included. This applies to all components, kits, and chassis. If the component part number is not known, the order should include the number of the chassis or kit of which it is a part, and sufficient description of the desired component to identify it.

Crystal and channel element orders should specify the crystal or channel element type number, crystal and carrier frequency, and the model number in which the part is used.

## Parts Ordering

7:00 A. M. to 7:00 P. M. (Central Standard Time)  
Monday through Friday (Chicago, U. S. A.)  
Domestic (U. S. A.): 1-800-422-420, or 847-538-8023  
1-800-826-1913, or 410-712-6200 (Federal Government)  
TELEX: 280127  
FAX: 1-847-538-8198  
FAX: 1-410-712-4991 (Federal Government)  
Domestic (U. S. A.) after hours or weekends:  
1-800-925-4357  
International: 1-847-538-8023

## Motorola Parts

Accessories and Aftermarket Division  
(United States and Canada)  
Attention: Order Processing  
1313 E. Algonquin Road  
Schaumburg, IL 60196

Accessories and Aftermarket Division  
Attention: International Order Processing  
1313 E. Algonquin Road  
Schaumburg, IL 60196

## Parts Identification

1-847-538-0021 (Voice)  
1-847-538-8194 (FAX)

---

## Related Documents

*Quantar User's Guide* (Motorola part number 68P81095E05)

*RSS User's Guide* (Motorola part number 68P81085E35)

# Safety Information

---

## General

This section contains important information on safe and efficient operation. Read this information before using your radio.

---

## Safe and Efficient Operation of Motorola Two-way Radios

The information provided in this document supersedes the general safety information contained in user guides published prior to July 2000. For information regarding radio use in a hazardous atmosphere please refer to the Factory Mutual (FM) Approval Manual Supplement or Instruction Card, which is included with radio models that offer this capability.

---

## RF Operational Characteristics

Your radio contains a transmitter and a receiver. When it is ON, it receives and transmits radio frequency (RF) energy.

---

## Exposure to Radio Frequency Energy

Your Motorola radio is designed to comply with the following national and international standards and guidelines regarding exposure of human beings to radio frequency electromagnetic energy (EME):

- United States Federal Communications Commission, Code of Federal Regulations; 47 CFR part 2 sub-part J
- American National Standards Institute (ANSI) / Institute of Electrical and Electronic Engineers (IEEE) C95. 1-1992
- Institute of Electrical and Electronic Engineers (IEEE) C95.1-1999 Edition
- National Council on Radiation Protection and Measurements (NCRP) of the United States, Report 86, 1986
- International Commission on Non-Ionizing Radiation Protection (ICNIRP) 1998
- National Radiological Protection Board of the United Kingdom 1995
- Ministry of Health (Canada) Safety Code 6. Limits of Human Exposure to Radiofrequency Electromagnetic Fields in the Frequency Range from 3 kHz to 300 GHz, 1999



- Australian Communications Authority Radiocommunications (Electromagnetic Radiation - Human Exposure) Standard 1999 (applicable to wireless phones only)

---

## Electromagnetic Interference/ Compatibility

**NOTE:** Nearly every electronic device is susceptible to electromagnetic interference (EMI) if inadequately shielded, designed or otherwise configured for electromagnetic compatibility.

### Facilities

To avoid electromagnetic interference and/or compatibility conflicts, turn off your radio in any facility where posted notices instruct you to do so. Hospitals or health care facilities may be using equipment that is sensitive to external RF energy.

### Aircraft

When instructed to do so, turn off your radio when on board an aircraft. Any use of a radio must be in accordance with applicable regulations per airline crew instructions.

### Medical Devices

- **Pacemakers**

The Health Industry Manufacturers Association recommends that a minimum separation of 6 inches (15 cm) be maintained between a handheld wireless radio and a pacemaker. These recommendations are consistent with the independent research by, and recommendations of, Wireless Technology Research.

Persons with pacemakers should:

- ALWAYS keep the radio more than 6 inches (15 cm) from their pacemaker when the radio is turned ON.
- not carry the radio in the breast pocket.
- use the ear opposite the pacemaker to minimize the potential for interference.
- turn the radio OFF immediately if you have any reason to suspect that interference is taking place.

- **Hearing Aids**

Some digital wireless radios may interfere with some hearing aids. In the event of such interference, you may want to consult your hearing aid manufacturer to discuss alternatives.

- **Other Medical Devices**

If you use any other personal medical device, consult the manufacturer of your device to determine if it is adequately shielded from RF energy. Your physician may be able to assist you in obtaining this information.

---

## Operational Warnings

- Vehicles with an air bag



**WARNING:** Do not place a portable radio in the area over an air bag or in the air bag deployment area. Air bags inflate with great force. If a portable radio is placed in the air bag deployment area and the air bag inflates, the radio may be propelled with great force and cause serious injury to occupants of the vehicle.

- Potentially explosive atmospheres



**WARNING:** Turn off your radio prior to entering any area with a potentially explosive atmosphere, unless it is a radio type especially qualified for use in such areas as “Intrinsically Safe” (for example, Factory Mutual, CSA, or UL Approved). Do not remove, install, or charge batteries in such areas. Sparks in a potentially explosive atmosphere can cause an explosion or fire resulting in bodily injury or even death.

**NOTE:** The areas with potentially explosive atmospheres referred to above include fueling areas such as below decks on boats, fuel or chemical transfer or storage facilities, areas where the air contains chemicals or particles, such as grain, dust or metal powders, and any other area where you would normally be advised to turn off your vehicle engine. Areas with potentially explosive atmospheres are often but not always posted.

- Blasting caps and areas



**WARNING:** To avoid possible interference with blasting operations, turn off your radio when you are near electrical blasting caps, in a blasting area, or in areas posted: “Turn off two-way radio.” Obey all signs and instructions.

---

## Operational Cautions

- Damaged antennas



**CAUTION:** Do not use any portable radio that has a damaged antenna. If a damaged antenna comes into contact with your skin, a minor burn can result.

- Batteries



**CAUTION:** All batteries can cause property damage and/or bodily injury such as burns if a conductive material such as jewelry, keys, or beaded chains touch exposed terminals. The conductive material may complete an electrical circuit (short circuit) and become quite hot. Exercise care in handling any charged battery, particularly when placing it inside a pocket, purse, or other container with metal objects.

---

## Mobile Radio Operation and EME Exposure

To assure optimal radio performance and that human exposure to radio frequency electromagnetic energy is within the guidelines referenced earlier in this document, transmit only when people outside the vehicle are at least the minimum distance away from a properly installed, externally-mounted antenna.

The table below lists the minimum distance for several different ranges of rated radio power.

*Table 1: Rated Power and Distance*

<b>Rated Power of Vehicle-Installed Mobile Two-Way Radio</b>	<b>Minimum Distance from Transmitting Antenna</b>
7 to 15 Watts	1 Foot (30.5 Centimeters)
16 to 50 Watts	2 Feet (61 Centimeters)
More than 50 Watts	3 Feet (91.5 Centimeters)

---

## **Antenna Installation**

### **Mobile Antennas**

**Recommended mobile antenna installations are limited to metal body vehicles at the center of the roof and center of the trunk deck locations.**

The antenna installation must additionally be in accordance with:

- a. The requirements of the antenna manufacturer/supplier
- b. Instructions in the Radio Installation Manual

### **Fixed Site Antennas**

Mobile radio equipment is sometimes installed at a fixed location and operated as a control station or as a fixed unit. In such cases the antenna installation must comply with the following requirements in order to assure optimal performance and make sure human exposure to radio frequency electromagnetic energy is within the guidelines set forth in the above standards.

- The antenna must be mounted outside the building.
- Mount the antenna on a tower if at all possible.
- If the antenna is to be mounted on a building then it must be mounted on the roof.
- As with all fixed site antenna installations, it is the responsibility of the licensee to manage the site in accordance with applicable regulatory requirements and may require additional compliance actions such as site survey measurements, signage, and site access restrictions in order to insure that exposure limits are not exceeded.

# Introduction

---

## General

The Motorola PDR 3500 Station provides conventional analog, *ASTRO*<sup>™</sup>, *ASTRO CAI*<sup>™</sup>, and *SECURENET*<sup>™</sup> capabilities in a compact, software-controlled design. The station architecture and microprocessor-controlled Station Control Module allow for fast and reliable upgrading. FLASH memory in the Station Control Module allows software updates to be performed locally (using serial port), or remotely via modem.

## Compact Mechanical Design

The entire unit is housed in a lockable rugged, black aluminum extruded case weighing approximately 41 lbs. Internal components are mounted in a custom, removable chassis, designed to fit a 19" rack.

---

## State-of-the-Art Electrical Design

### Transmitter Circuitry

The station transmitter circuitry is designed for 50% duty cycle operation at full rated power. Output power is continuously monitored by an internal calibrated wattmeter. The wattmeter output feeds a power control loop, continually adjusting and maintaining the desired output power. All adjustments are electronic, including deviation and output power.

### Receiver Circuitry

The station receive circuitry features multiple bandwidth capability (12.5, 25, or 30 kHz, depending on band), as well as *ASTRO* digital operation. Injection signals for the 1st and 2nd local mixers are generated by frequency synthesizer circuitry and are electronically controlled by the Station Control Module. All receive signals (analog, *SECURENET*, *ASTRO*, and *ASTRO CAI*) are detected and digitized before being sent to the Station Control Module; this provides improved audio quality, consistent throughout the coverage area.

### Station Control Module

The Station Control Module is microprocessor-based and features extensive use of ASIC and digital signal processing technology. The module serves as the main controller for the station, providing signal processing and operational control for the station modules.

## Wireline Circuitry

The station wireline circuitry provides a wide variety of telephone interfaces, including analog, *ASTRO*, *ASTRO CAI*, *SECURENET*, Tone Remote Control, and DC Remote Control. Telephone line connections are easily made to the wireline circuitry via connectors on the top panel.

## Switching Power Supply

The station features a switching-type power supply, accepting a wide range of AC inputs (85-265 VAC, 49-61 Hz). The power supply generates 13.8 VDC for the station modules.

---

## Standard Features

- Compact single case design
- Extensive Self-Test Diagnostics and Alarm Reporting
- FRU maintenance philosophy
- Easily programmed via Radio Service Software
- Local or Remote Software downloading to FLASH memory
- Upgrades performed by module replacement and/or software upgrade
- Compatible (with appropriate options) with analog, *SECURENET*, *ASTRO*, and *ASTRO CAI* digital signaling
- Versatile and reliable switching-type power supply
- Wide operating temperature range: -30° C to + 60° C (-22° F to +140° F)

---

## Optional Hardware Features

- Duplexer Option – allows a single antenna to serve for both transmitter and receiver circuitry for repeater applications.
- Antenna Relay Option – allows a single antenna to be switched between transmitter and receiver.
- *ASTRO* Modem – allows connection (for *ASTRO* digital signaling) to a console through a Digital Interface Unit (DIU) in an *ASTRO* system, also allows connection to another *ASTRO* Modem for digital Cross-Patch.

# System Applications

---

## Local Control

The PDR 3500 is an APCO 25 digital repeater. The station is identical in operation to the Quantar station, hence there is no local control capability. There is no digital-to-audio translation within the station. Local control style operation can be accomplished in several ways:

- a. A portable radio may be used as an RF control station talking to the repeater.
- b. The station may be equipped with the wireline and the modem options and routed through a DIU to a tone remote console. The Tone remote console controls the station via wireline through the DIU. The wireline in this case is a local 4-wire cable.

---

## Two Antenna Operation

The PDR 3500 Portable Digital Repeater may be operated with the internal duplexer, using a single antenna. The duplexer provides the necessary electrical isolation between the transmitter and the receiver frequencies for repeater operation. The same isolation can be obtained by physically separating transmit and receive antennas either horizontally or vertically. The repeater requires approximately 50 dB isolation between the transmit and receive antennas for proper operation.

### Horizontal Antenna Separation:

VHF Band	275 feet
UHF Band	75 feet
800 MHz Band	40 feet

The Isolation values shown are for dipole antennas. If gain antennas are used, additional separation is required. For example, if both receive and transmit antennas have 3dB gain each, an additional 6 dB isolation is required. At UHF frequencies, an additional 75 feet separation is required.

### Vertical Antenna Separation (tip of one antenna to the base of the other):

VHF Band	23 feet
UHF Band	9.5 feet
800 MHz Band	4 feet

Gain antennas do not effect the transmit-to-receive antenna separation required. Gain antennas are longer than unity gain antennas. Therefore additional tower height will be required to maintain the tip-to-base separation.

The antenna isolation distances shown above are based upon ideal conditions. The antenna-to-antenna coupling is affected by nearby objects that may result in increased separation required for proper operation. The antenna coax cable must be a double-shielded type to minimize cable-to-cable coupling. If RG58 style cables have to be used, keep the cables as far apart as possible to minimize cable coupling.

---

### **External Duplexer Operation**

The PDR 3500 must be used with an external duplexer when frequency spacing is less than 3 MHz. The duplexer isolation required for proper operation is approximately 60 dB. Double-shielded coaxial cables must be used from the repeater to the duplexer.

---

### **Repeater RA or Cross Band Repeater Operation**

The PDR 3500 can be configured for Repeater RA or cross band repeater operation by adding the wireline card and the Astro modem to the each repeater. The repeaters are connected together using the wireline port on each repeater. The cables are terminated in RJ-45 connectors.

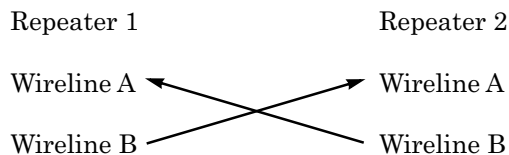





**Table 3: Options**

OPTION DESIGNATOR	DESCRIPTION	PURPOSE
Q245AL	Add: Duplexer, VHF	Adds VHF duplexer. Requires customer frequency.
Q245AM	Add: Duplexer, UHF	Adds UHF duplexer. Requires customer frequency.
H338AC	Add: Transit Case	Adds a transit case for increased protection during transport.

## Maintenance Specifications

The following are the PDR 3500 specifications for analog as measured per the revised EIA/TIA 603 Standards and for digital as measured per TIA TSB-102.CAAB:

**Table 4: Specifications**

GENERAL	VHF	UHF
Standard model numbers	P2066A, P2067A	P2068A, P2069A, P2070A, P2071A
Channel spacing	12.5, 25, 30 kHz	12.5, 25 kHz
Stability	0.0001%	0.0001%
Preselector bandwidth (3dB)	7 MHz	7 MHz
Squelch	Carrier, PL, DPL	Carrier, PL, DPL
Number of modes	1	1
TRANSMITTER	VHF	UHF
RF power (without duplexer)	30 watts	30 watts
RF power (with duplexer)	20 watts	20 watts
Maximum transmit duty cycle	50%	50%
TX spurs/harmonics	-60 dB	-60 dB
FM noise (EIA)	-45 dB nominal	-45 dB nominal
Audio response	per EIA	per EIA
TX distortion (1 kHz, clear audio)	<5%	<5%
RECEIVER	VHF	UHF
Sensitivity (20dBQ)	0.35 uV	0.5 uV
Sensitivity (12dB SINAD)	0.25 uV	0.35 uV
Selectivity (EIA SINAD)	85 dB (25/30 kHz)	85 dB (25 kHz)
	75 dB (12.5 kHz)	75 dB (12.5 kHz)
Intermod (EIA SINAD)	80 dB (25/30 kHz) 75 dB (12.5 kHz)	75 dB
Spurious and image	80 dB	80 dB

*Note: Specifications are subject to change without notice.*

**Table 5: Specifications, continued**

<b>DUPLEXER</b>	
Repeat frequency spread, TX/TX:	300 kHz
VHF minimum duplexer T-R separation 3 MHz:	132-174 MHz
UHF minimum duplexer T-R separation 3 MHz:	403-520 MHz
AC power voltage range:	80-265 Vac
AC power frequency input:	49-61 Hz
External DC power:	11-16 Vdc
<b>CURRENT DRAIN</b>	
High power repeat:	10.0 A
Standby:	1.9 A
<b>DIMENSIONS</b>	
Size (English):	20.00 x 15 x 7.75 inches
Size (metric):	508 X 381 X 197 mm
<b>WEIGHT</b>	
Weight (English):	41 lbs
Weight (metric):	18.6 kg

*Note: Specifications are subject to change without notice.*



# Approved Accessories

---

## General

The following accessories are recommended by Motorola for use with the PDR 3500 Portable Repeater.

---

## Antenna

One of the following antennas should be used:

- The magnetic-mount whip antenna (Motorola part number PAN6003A) shipped with the PDR 3500.

**NOTE:** This antenna should be cut to frequency before use per the manufacturer's instructions enclosed with the antenna.

- An aftermarket antenna which meets these requirements:
  - Monopole
  - Unity gain
  - Tuned to the frequency at which the antenna is to be used
  - Minimum input power rating of 60W continuous
  - VSWR of 1.5:1 or less



# Setup and Connections

## Programming with RSS

### Introduction

The PDR 3500 uses the same RSS (Radio Service Software) as the Quantar/Quantro family. Some values shown in RSS screens may not be valid due to hardware differences between the Quantar Station and the PDR 3500. A thorough explanation of the differences will be given in the following sections.

### Connecting PC to PDR 3500 RSS Port

Once the RSS Program has been loaded onto the PC (refer to *Quantar RSS User's Guide*, 68P81085E35), the PC must be electrically connected to the PDR 3500 via the RSS port located on the top panel. For this connection, a 9-pin female to 9-pin male EIA-232 cable is available (Motorola part number 30-80369E31) from the Accessories and Aftermarket Product Division (AAD, formerly known as Motorola National Parts). A cable can also be made using the wiring diagram in Figure 1.

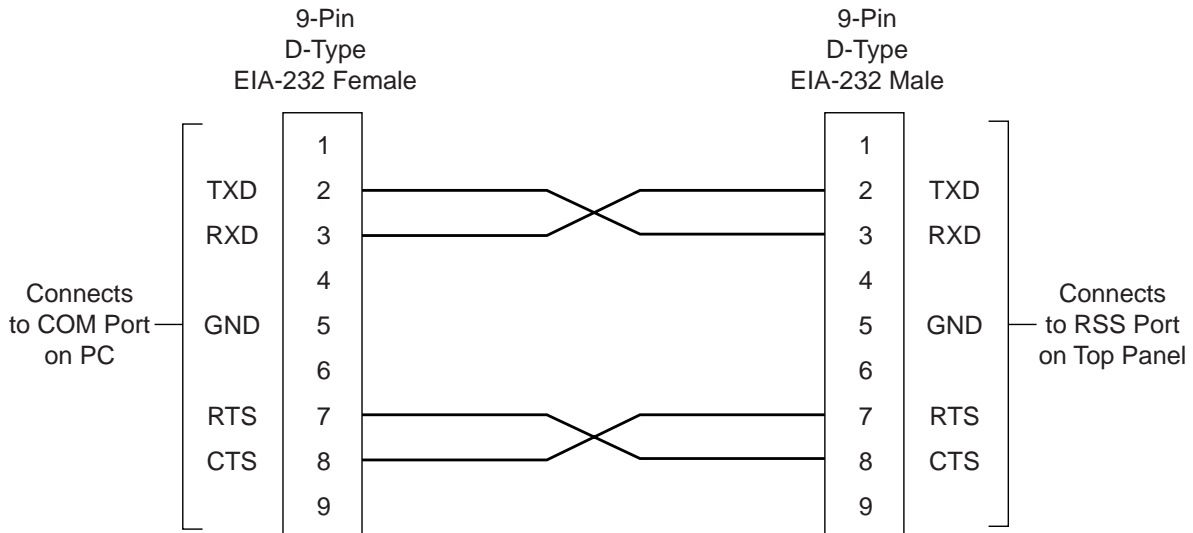

MAEPF-27075-O

Figure 1. EIA-232 Wiring Diagram

Connect one end of the cable to COM1 on the PC and the other end to the 9-pin connector labeled “RSS” on the top panel of the PDR 3500.

## Using the RSS

For information on starting the RSS, configuring screen colors, setting up the PC serial port, and general RSS use, refer to the *Quantar RSS User’s Guide* (68P81085E35).

## Hardware Configuration

From the Main Menu, press “F2-Service.” Press F2 again to arrive at the Hardware Configuration Screen.

1. The first field to verify is the **Hardware Platform** field. The PDR 3500 is designed using the Quantar profile; it will not operate properly in any other mode.
2. The next field to verify is the **System Type** field. This field should be set to “Conventional.” The PDR 3500 does not operate as an ASTRO-TAC Receiver or DBS Base Station.
3. Next verify that the **Rx Freq Band 1** and **Tx Freq Band** fields list the correct ranges for receiver and transmitter.

**NOTE:** **Rx Freq Band 2** should be set to “NONE.”

4. The **PA Power Rating** field should be set to 25W (low power), and the **Power Supply** field should show “AC LOW.” The PDR 3500 was designed using a Quantar low power station profile. It will not operate properly using any other configuration.
5. If the unit is equipped with a Wireline Card, verify that the **Wireline** field under the options is set to 4-wire.

Once the Hardware Configuration Screen matches the installed station hardware, press F8 to validate the configuration. A popup message will notify the user of any errors in the configuration. For a complete description of the **Hardware Configuration** fields, please refer to the *Quantar RSS User’s Guide* (68P81085E35).

## Alignment

From the Main Menu, press “F2-Service.” Now press “F3” to arrive at the Alignment Menu. From this menu, the user may align the RF Power Out, RSSI, Station Squelch, and BER.

For instructions on performing Rx or Tx Wireline Alignment, please refer to the *Quantar RSS User’s Guide* (68P81085E35).

**NOTE:** Before performing any alignment procedures, first dekey the station and “Access Disable” the repeater as shown in step 1 below.

### 1. **Access Disable:**

1. From the main menu, press “F2-Service.”
2. Press “F6-Status Panel/Software Ver/Set Date and Time.”
3. Press F2 to arrive at the Status Panel Display Screen.
4. From this screen, press F6 to activate the Access Disable function. In this mode, the station will not keyup in response to a received signal. To deactivate the Access Disable function, press shift+F6.

### 2. **RSSI Calibrate:**

1. In the Alignment Menu Screen, tab over to the **RSSI Calibrate** field, and press F2 to perform the alignment.
2. Using an R2670 or equivalent Communications System Analyzer, connect the RF out from the Analyzer to the Rx UHF-type connector on the station top panel.
3. Set the RF output level from the Analyzer to –90 dBm with no modulation, and set the frequency to PDR 3500 receive frequency.
4. With the Analyzer RF turned on, make sure the value shown in the RSS screen is –90 dBm. If it is not, type in “–90 dBm.”
5. Press F8 to save the calibration.

### 3. **Power Out:**

1. In the Alignment Menu Screen, tab over to the **Tx Power** field and press F2 to perform the alignment.
2. For this procedure, connect the Tx UHF-type connector on the station top panel to the RF input of either a Motorola R-2670 Communications Analyzer, or to the input of an RF power meter.
3. Press F6 to keyup the station, check the output power level shown on the R2670 or RF power meter, and press F9 to dekey the station.
4. Enter the power from the meter in the field shown in the RSS, then hit F7 for the PDR 3500 to adjust the PA power output level.
5. Once the unit adjusts the power, again keyup the station, read the RF power from the meter, dekey the station, enter the level in the RSS field, and hit F7 again to adjust.
6. Repeat this cycle until the power out is as close to 25 Watts as possible. If the power output will not adjust properly, hit F4 to initialize the PA and restart the alignment procedure.



7. Once the power out is aligned, press F8 to save the settings to the station codeplug.

#### 4. **Squelch:**

1. From the Alignment Menu, tab over to the **Squelch Adjust** field and press F2 to perform the alignment. The Squelch control bar is shown in the center of the screen.
2. To open the squelch completely, press F2. To close the squelch completely, press F4. To adjust the squelch between fully open and fully closed, use the Pg Up/Pg Dn keys on the PC.
3. Once the squelch is set, press F8 to save the setting to the station codeplug.

#### 5. **ASTRO Bit Error Report:**

1. From the Alignment Menu, tab over to the V.52 Rx BER and RSSI Report, or PROJECT 25 Rx BER and RSSI Report.
2. Connect the R2670 Communications System Analyzer RF “OUT” port to the Rx UHF-type connector on the station top panel.
3. Set the generate frequency to the PDR 3500 receive frequency, and the output level to -113 dBm, with modulation either V.52 or Project 25 1011 Pattern generation.
4. Press F2 to perform the alignment. The values for the report will appear on the RSS screen.

## **Channel Information**

From the Main Menu, press F4. Press F4 again to arrive at the Channel Information Screen. From this screen, the user may configure the TX/RX frequencies, RF power out, modulation type, and the various channel traits for up to 16 channels.

1. In this screen, first set the Rx1 and Tx frequency to the proper values.

**NOTE:** The Rx2 frequency is set to 0.00000 MHz and cannot be edited. This is because the PDR 3500 does not allow for 2 receivers. The station will automatically calculate the Tx Idle Frequency to be the same as the Tx Frequency.

In most applications, the Tx Idle Frequency should remain the same as the Tx Frequency. However, in case of portable or mobile radios unsquelching near the PDR 3500, adjust the Tx Idle frequency to Tx Frequency -6.25 kHz.

2. Set the modulation type to either Analog, ASTRO, ASTRO CAI,

Analog/ASTRO CAI, or CAI RX WIDE DEV.

3. Move to page 2 of the Channel Information Screen by pressing the Pg Dn key. Set the Tx Power Out to the desired power level. (The **Battery Backup** field has no effect on station operation since there is no battery option for the PDR 3500.)

For a more complete description of the **Channel Information** fields, please refer to the *Quantar RSS User's Guide*.

---

## Electrical Connections

### Power Supply Connections

- AC Input Power Connection

Each PDR 3500 is shipped with an eight foot, 3-conductor line cord. Attach the receptacle end of the cord to the AC input plug located on the station top panel. Plug the 3-prong plug into a 110 V or 220 V AC grounded outlet.

**NOTE:** The Power Supply module automatically selects between 110 V and 220 V.

- DC Input Power Connection

An optional six foot, fused 2-conductor DC power cord is available. Attach the alligator clip leads (Red "+", Black "-") to an external battery or some other DC source set to +12 V. Plug the molded connector end to the external DC connector on the top panel.

**NOTE:** The top panel external DC connector will not charge an external battery.

### RF Cabling Connections

#### Introduction

The transmit and receive antenna RF connections may be made in one of two fashions depending on the system application.

- Separate TX and RX antennas.

The PDR 3500 top panel has two UHF-type connectors: one for RX, and one for TX. In this configuration there is a separate antenna for each connector.

- Duplexer

Using this configuration, only one antenna is required for both transmit and receive. The duplexer is mounted to the station top panel and has a single N-type connector for the antenna. An N-to-UHF adapter is provided.

### **Separate RX and TX Connectors**

In order to use two antennas, first disconnect the duplexer (if equipped). Connect the Rx antenna to the UHF connector labeled “RX” on the top panel, and the Tx antenna to the UHF connector labeled “TX” (Figure 2). Please refer to the Antenna Spacing Chart on page 4-1 in this manual.

### **Duplexer**

The duplexer allows the PDR 3500 to use a single antenna for both transmit and receive.

1. Connect the UHF connector labeled “RX” on the station top panel, to the N-type connector labeled “RX” on the duplexer.
2. Connect the top panel UHF connector, labeled “TX,” to the N-type connector labeled “TX” on the duplexer .
3. Connect the antenna UHF-type connector to the connector labeled “ANT” on the duplexer.

# Operation



## Description

This section describes the switches, pushbuttons, connectors, and LED indicators on the PDR 3500 station used during local operation of the station and servicing.

## Summary of Switches, Pushbuttons, and Connectors

The following switches, pushbuttons, and connectors allow the station to be operated or serviced locally. See Figure 2 for the location and function of these controls and connectors.

**Table 6 Switches, Pushbuttons, and Connectors**

Top Panel	
Wireline connectors	Transmit UHF connector
RSS port connector	Receive UHF connector
DC connector	
AC connector	
Momentary PTT/Reset switch	

## Summary of LED Indicators

**NOTE:** Refer to the Troubleshooting section of this manual for the detailed descriptions and interpretation of the LED indicators.

The following LED indicators are provided to show the operating status of the station. See Figure 2 for the location of these indicators.

**Table 7 Summary of LED Indicators**

Top Panel	Station Control Module
Power/Transmit LED	Station On
	Station Fail
	Intcm/Acc D
	Control Ch
	Rx 1 Active
	Rx2 Active
	Rx Fail
	Aux LED

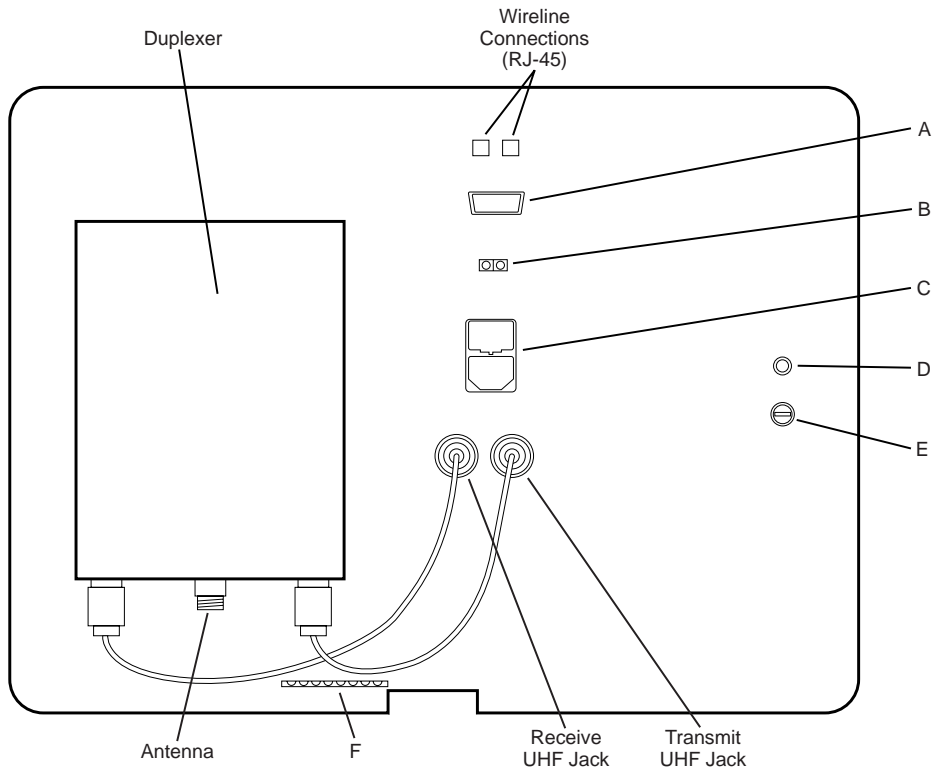

MAEPF-27065-O

Figure 2 . Switches , Pushbuttons , Connectors, and LED Indicators for PDR 3500

**Table 8 Switches, Pushbuttons, and LED Indicators**

Item	Name	Purpose
A	EIA-232 RSS Port Connector	Used to connect an IBM® PC (or compatible PC), running RSS software. Performs station alignment, optimization, and diagnostics. Requires Null Modem Cable (Motorola part number 30-80369E31).
B	DC Connector	External DC source (+12 Vdc)
C	AC Connector and Fuses	AC Inlet (110/220 Vac, 3 A)
D	Power/Transmit LED	The function of this LED indicator is described in the Troubleshooting section of this manual.
E	Momentary PTT/Reset Switch	When set to "PTT," its purpose is to test the station. When set to "RESET," its purpose is to reset the station.
F	Control Module Status LEDs	The function of these LED indicators is described in the Troubleshooting section of this manual. The LED indicators are (from right to left): Station On; Station Fail; Intcm/Acc D; Control Ch; Rx 1 Active; Rx2 Active; Rx Fail; Aux LED.

# Troubleshooting

---

## Introduction

This section provides troubleshooting recommendations and procedures for the PDR 3500 station and associated ancillary equipment.

## Troubleshooting Overview

The troubleshooting procedures and supporting diagrams allow the service technician to isolate station faults to the module/assembly level, or to a limited portion of the motherboard circuitry.

The following information is included:

- Alarm indicators and their functions
- Troubleshooting flow charts
- Module replacement procedures
- Post-repair procedures: Performing alignment after replacing defective modules

---

## Recommended Test Equipment

Follow this list of recommended test equipment when performing troubleshooting procedures on the PDR 3500 station and ancillary equipment:

## Test Equipment List

- Motorola R2001 or R2600 Series Communications Analyzer (or equivalent)
- PC with RSS program
- In-Line Wattmeter (Motorola S-1350, or equivalent)
- Dummy Load (50 $\Omega$ , station wattage or higher)
- Handset/Microphone with PTT switch (TMN6164, or equivalent)

---

## Troubleshooting Procedures

The troubleshooting and repair philosophy employs Field Replaceable Unit (FRU) substitution. The PDR 3500 station is comprised of self-contained modules (FRUs). Replacing faulty modules should bring the station back to normal operation.

Many of the troubleshooting procedures require the use of the Motorola-supplied Radio Service Software (RSS) since the PDR 3500 station is computer-controlled, employing state-of-the-art signal processing. The RSS operates on a PC (or compatible), with RS-232 communication port capability. The RSS allows the technician to access alarm logs, run diagnostics, and set up the equipment for various audio and RF tests. Complete details on the operation of the RSS are provided in the *RSS User's Guide* (manual number 68P81085E35).

## Troubleshooting Overview

### Introduction

Two procedures are provided for troubleshooting the PDR 3500 station and ancillary equipment. Each procedure is designed to quickly identify faulty modules, and replace them with known working modules.

### Procedure 1: Routine Maintenance Functional Checkout

Procedure 1 is a series of non-intrusive tests, performed during a routine maintenance. The technician verifies proper station operation. An overview of the procedure is shown in the flowchart (Figure 3).

### Procedure 2: Troubleshooting A Reported/Suspected Problem

Procedure 2 should be used when an equipment problem has been either reported or is suspected. The procedure includes tests that allow the technician to troubleshoot reported or suspected equipment malfunctions. An overview of the procedure is shown in the flow chart (Figure 4).

### How to Use These Troubleshooting Procedures

Perform the following basic steps in order to efficiently troubleshoot the PDR 3500 station equipment.

- Step 1. Select the appropriate troubleshooting procedure flow chart (Procedure 1 or Procedure 2).
- Step 2. Perform the selected flow chart tasks. Tasks requiring additional explanation are marked with page references.
  - Locate the additional information
  - Perform the tasks (if any)
  - Return to the flow chart
- Step 3. Once the faulty module has been identified, proceed to *Module Replacement Procedures*, beginning on page 25.

**PROCEDURE 1**

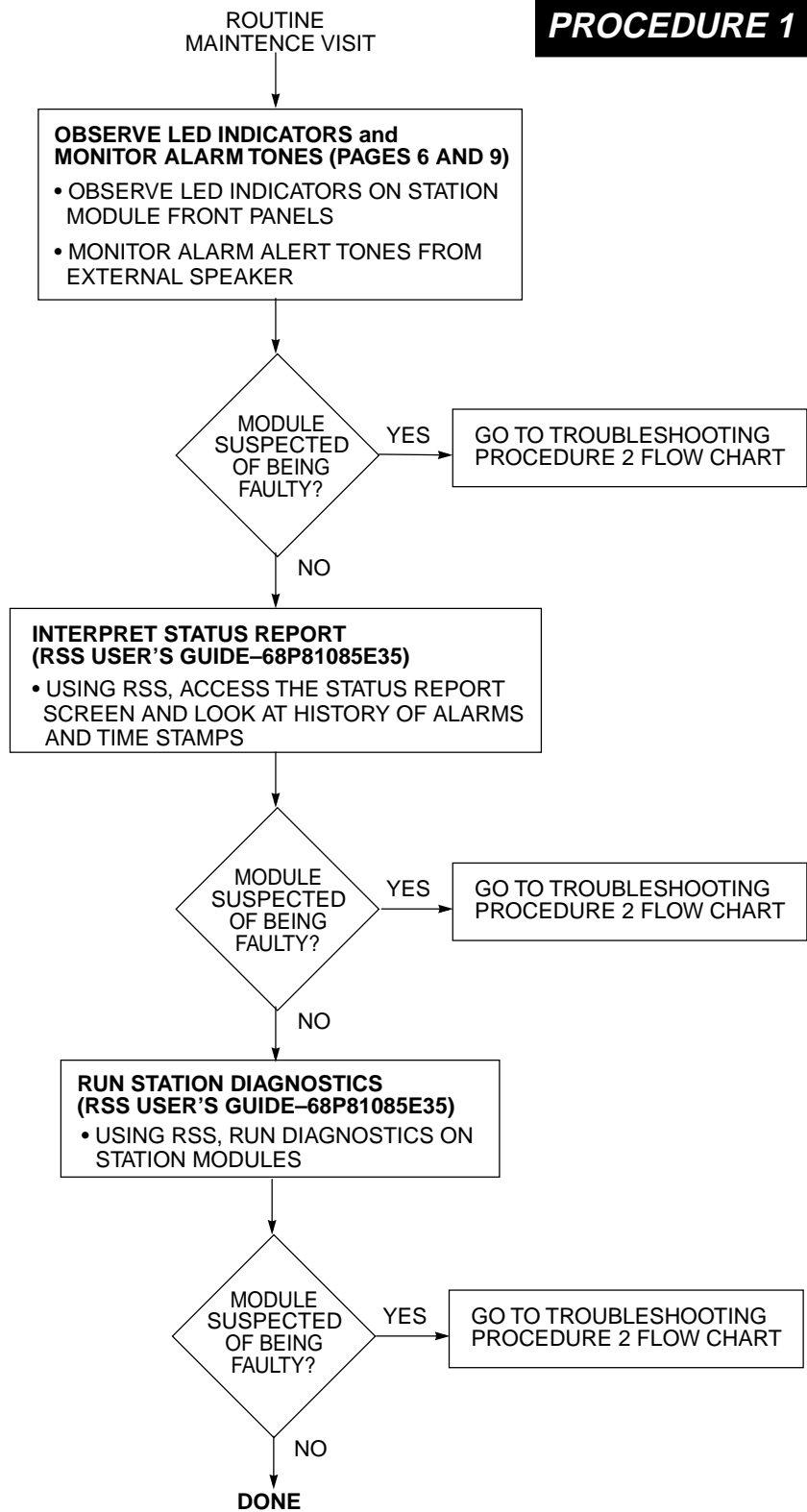

Figure 3 PDR 3500 Station Troubleshooting Overview (Procedure 1: Routine Maintenance)



**PROCEDURE 2**

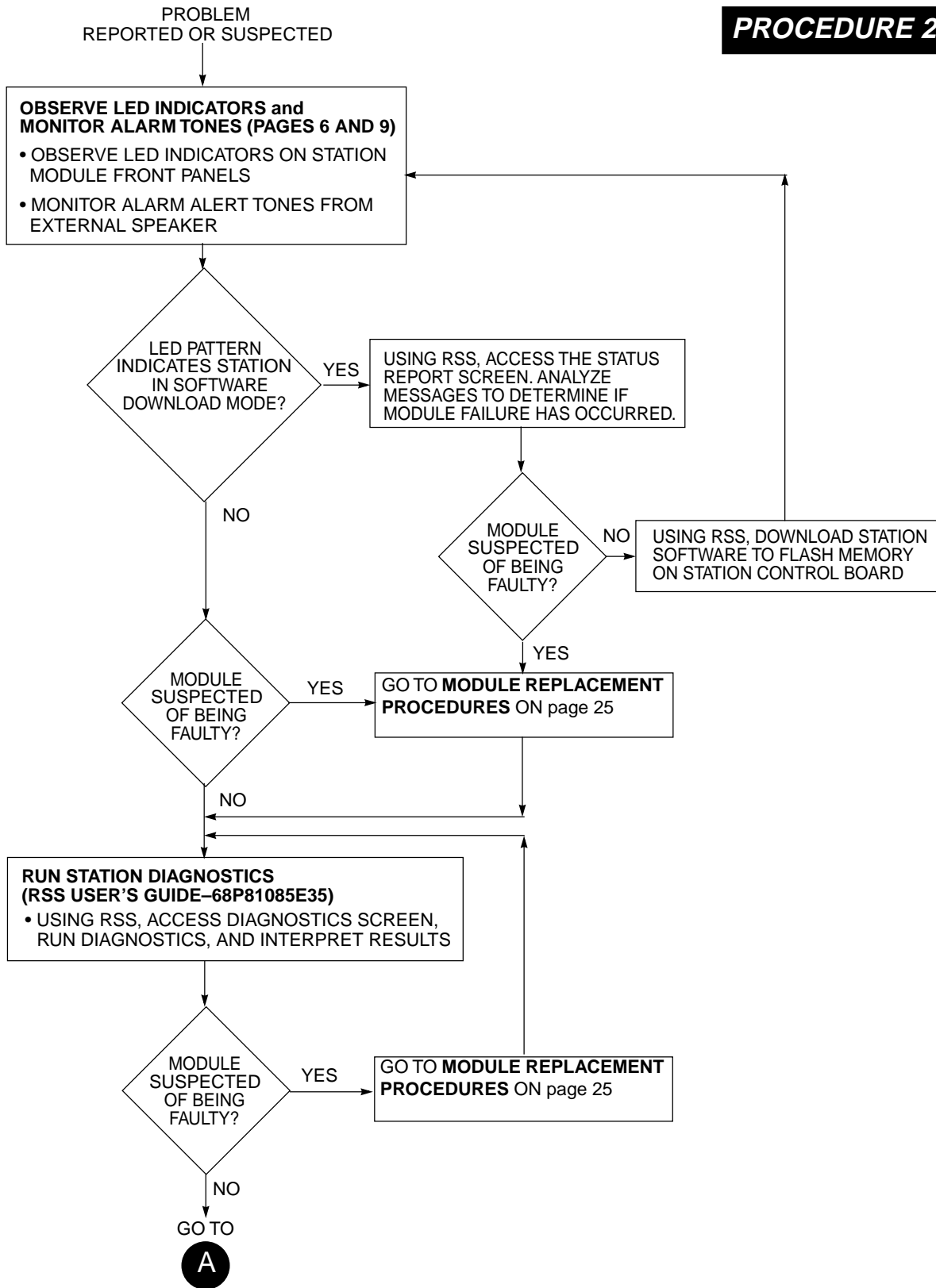

Figure 4 PDR 3500 Station Troubleshooting Overview (Procedure 2: Reported or Suspected Problem)

**PROCEDURE 2  
(CONTINUED)**

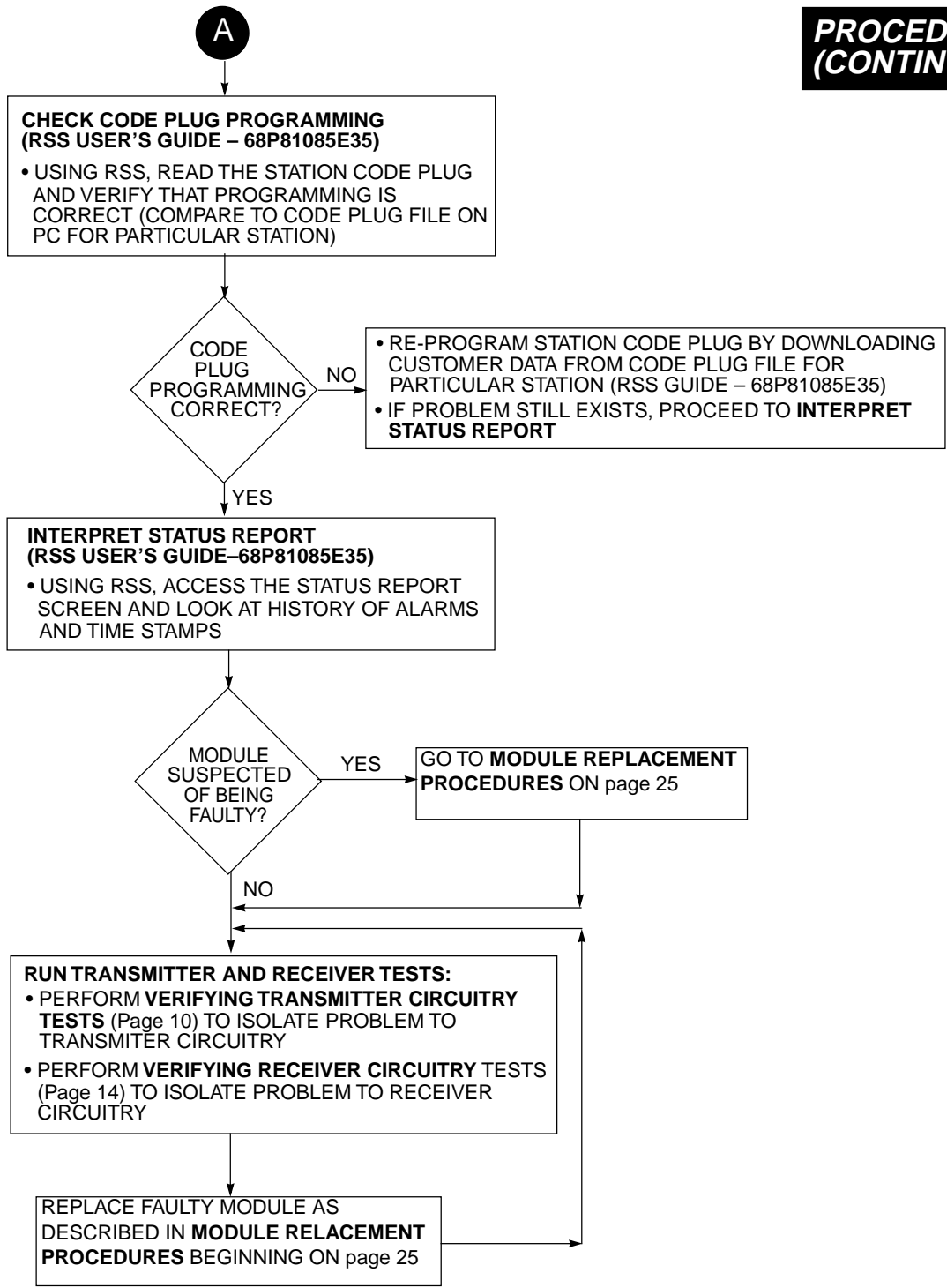

Figure 4 PDR 3500 Station Troubleshooting Overview (Procedure 2: Reported or Suspected Problem) (Continued)

## Interpreting LED Indicators

Several LED indicators are provided on the front panels and on the top panel of the chassis. These LEDs give a quick status indication of the station equipment. The Station Control Module LEDs are visible from the station's top panel. Observing the other LEDs requires the removal of the station's chassis from the case. See Figure 5 for the location of all LED indicators on the station's equipment. A listing of each LED indicator, along with a description of the status indicated by each LED, is shown in Table 9.

**Table 9: PDR 3500 Station LED Indicator Functions**

LED Location	LED Name	Status Definition
EXCITER MODULE	Tx Lock	<ul style="list-style-type: none"> <li>– GREEN when Exciter synthesizer is locked; module fully functional.</li> <li>– OFF when:               <ul style="list-style-type: none"> <li>synthesizer is out of lock</li> <li><i>or</i></li> <li>+5V, +14.2V, or both are absent</li> </ul> </li> </ul>
	PA Full	<ul style="list-style-type: none"> <li>– GREEN when transmitter is keyed and PA output power is at expected power level (as set by technician via RSS during station alignment)</li> <li>– OFF when:               <ul style="list-style-type: none"> <li>PA not keyed</li> <li><i>or</i></li> <li>PA keyed, but PA output power is <b>not</b> at expected power level (as set by technician via RSS during station alignment)</li> </ul> </li> </ul>
	PA Low	<ul style="list-style-type: none"> <li>– YELLOW when transmitter is keyed and PA output power is less than expected power level (as set by technician via RSS during station alignment) but not shut down (for example, during power cutback mode)</li> <li>– OFF when:               <ul style="list-style-type: none"> <li>PA not keyed</li> <li><i>or</i></li> <li>PA keyed, and PA output power is at expected power level (as set by technician via RSS during station alignment)</li> </ul> </li> </ul>
	PA Fail	<ul style="list-style-type: none"> <li>– RED when:               <ul style="list-style-type: none"> <li>No PA output power (for example, during PA shutdown mode); LED status is latched, thereby indicating status during current key or for previous key</li> </ul> </li> <li><b>NOTE:</b> Any component associated with the PA could cause LED to light. These include the Exciter, PA, and transmitter circuitry on the backplane.</li> <li>– FLASHING when PA is in the Test Mode (activated by technician via RSS; when in Test Mode, power cutback, and open power loop protection are disabled)</li> <li>– OFF when PA output power is either at expected level, or at specific cutback levels (any level other than shutdown); LED status is latched, thereby indicating status during current key, or for previous key.</li> </ul>
TOP PANEL	Pwr/Tx	<ul style="list-style-type: none"> <li>– GREEN when AC or DC input power is present</li> <li>– RED when station is transmitting</li> <li>– OFF when AC or DC input power is absent</li> </ul>

**Table 9: PDR 3500 Station LED Indicator Functions (Continued)**

LED Location	LED Name	Status Definition
STATION CONTROL MODULE (SCM)	STATION ON	<ul style="list-style-type: none"> <li>– GREEN when SCM fully functional</li> <li>– FLASHING when front panel switch press detected</li> <li>– OFF for SCM failure</li> </ul>
	Station Fail	<ul style="list-style-type: none"> <li>– RED for SCM failure</li> <li>– OFF when SCM fully functional (no failure)</li> </ul>
	Intcm/Acc D	<ul style="list-style-type: none"> <li>–YELLOW when station is in Intercom mode</li> <li>– FLASHING when station is in Access Disable mode</li> <li>– OFF when station is not in Intercom mode</li> </ul>
	Control Ch	<ul style="list-style-type: none"> <li>– GREEN when station is control channel (trunking systems only)</li> <li>– FLASHES each time station decodes IWS (<i>IntelliRepeater</i> systems only)</li> </ul>
	Rx 1 Active	<ul style="list-style-type: none"> <li>– GREEN when Station Control Board is passing audio/data (receive path unmuted) from Receiver #1; The following conditions must be met: <ul style="list-style-type: none"> <li>Carrier at proper frequency being received</li> <li>Carrier signal level is above threshold set in codeplug</li> <li>Squelch criteria met (carrier, PL, DPL, ASTRO, secure, etc.)</li> </ul>                     (Note that squelch criteria can be manually altered via RSS for testing purposes)                 </li> <li>– OFF when above conditions are not met for Receiver #1</li> </ul>
	Rx 2 Active	<ul style="list-style-type: none"> <li>– Unused in PDR 3500</li> </ul>
	Rx Fail	<ul style="list-style-type: none"> <li>– RED when receiver is non-functional*</li> <li>– BLINKING ONCE PER SECOND when Receiver #1 is non-functional*</li> <li>– BLINKING TWICE PER SECOND when Receiver #2 is non-functional* or when SAM module, or UHSO Module, is non-functional (unused in PDR 3500)</li> <li>– OFF when RECEIVER is functional* (or no receiver module installed)</li> </ul> <p>*A receive module is considered non-functional if a failure is detected during diagnostics run at time of power-up, or during normal operation</p>
	Aux LED	<ul style="list-style-type: none"> <li>– GREEN LED available for special application function</li> </ul>
	All LEDs Flashing On and Off in Unison	<ul style="list-style-type: none"> <li>– Station is in Software download mode, either initiated by the RSS, or due to software failure.</li> </ul>
LEDs Flashing Up and Down in Sequential Pattern	<ul style="list-style-type: none"> <li>– Station received software files from RSS and is in process of downloading the software to FLASH memory in the Station Control Module</li> </ul>	
WIRELINE INTERFACE BOARD (WIB)	WL On	<ul style="list-style-type: none"> <li>– GREEN when WIB fully functional</li> <li>– OFF for WIB failure</li> </ul>
	Both LEDs Blinking Rapidly	<ul style="list-style-type: none"> <li>– WIB is in Software Download mode (operating software is being downloaded into the FLASH memory on WIB from Station Control Module)</li> </ul>

**Notes:**

1. All LEDs momentarily light following station reset (Volume Up, Volume Down, and Intercom buttons on SCM front panel pressed simultaneously), or on station power-up.
2. If no LED indicators are on, make sure that AC or DC power to the station power supply is present. If using AC power, check top panel fuses. Check the circuit breaker at the source. Check the AC or DC line cord. If no problem is found and AC power is used, suspect the power supply.



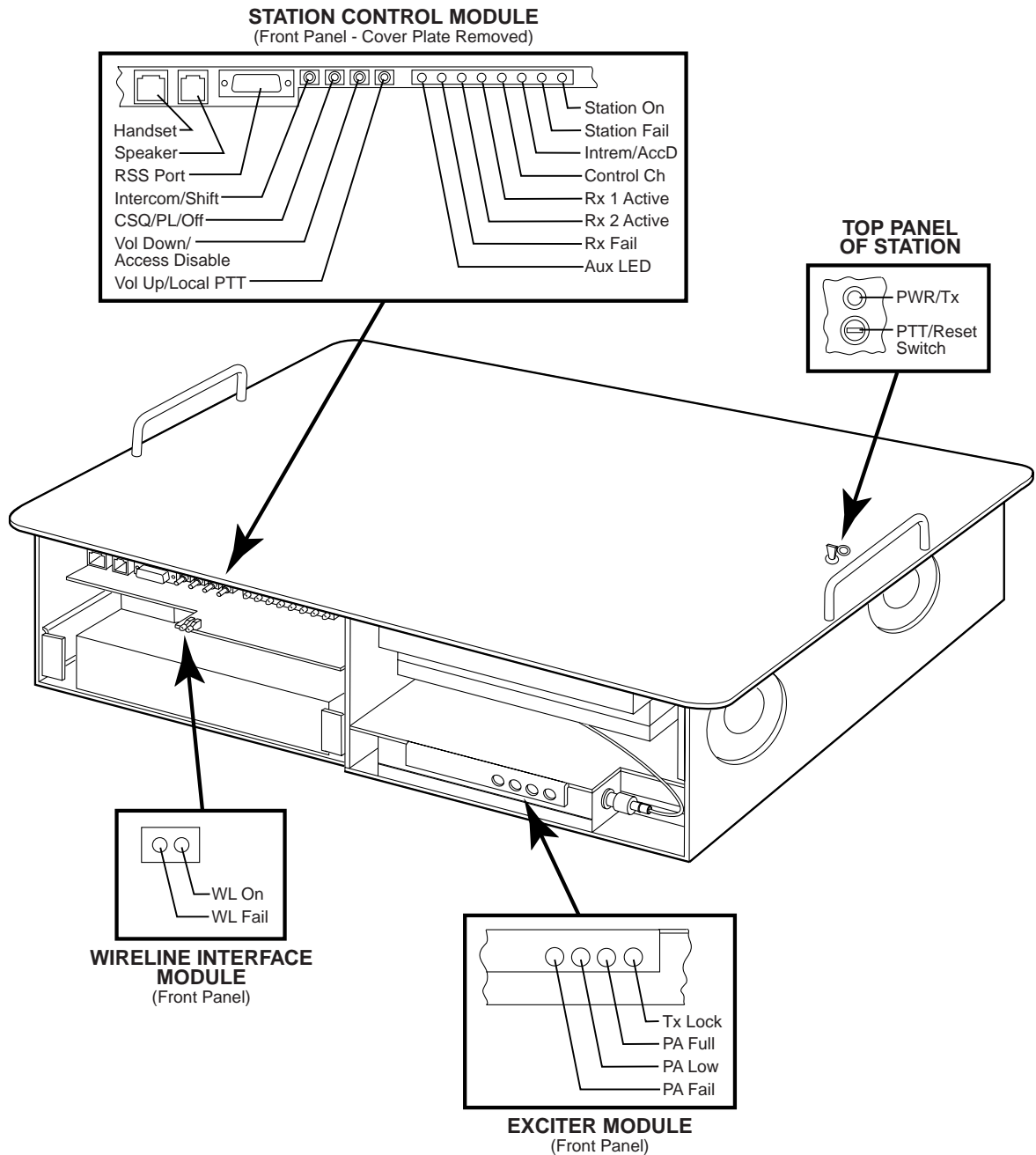

MAEPF-27030-O

*Figure 5 PDR 3500 LED Indicators and Front Panel Buttons and Connectors*

# Interpreting Alarm Alert Tones

## Introduction

Four station alarm conditions are reported with audio alert tones which are routed to the external speaker connector (RJ-11) on the front of the control module. (Pin 4 on the RJ-11 is Speaker High; Pin 1 is Speaker Ground.) The alarms are also entered into the alarm log which can be accessed using the RSS. Refer to the *RSS User's Guide*, part number 68P81085E35.

**NOTE:** The alarm tones may also be routed to the console (via the wireline) and transmitted over the air. Refer to the *RSS User's Guide* (part number 68P81085E35) for details on enabling or disabling these two alarm routing options.

The four alarm conditions are represented by a series of alarm tones, from a single beep, to four beeps. Each beep is a 1200 Hz tone, lasting 125 msec. The alarm tones occur during a repeating 10 second window, with two seconds between successive alarms (when more than one alarm is active). The following two examples illustrate the timing of the alarm tones.

### Example 1: Single Alarm (#3)

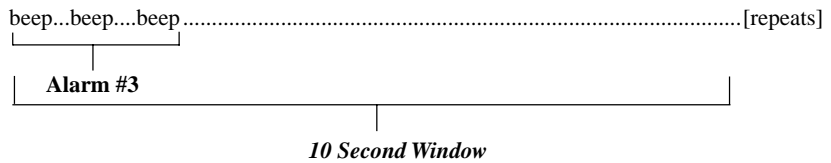

### Example 2: Multiple Alarms (#1 and #4)

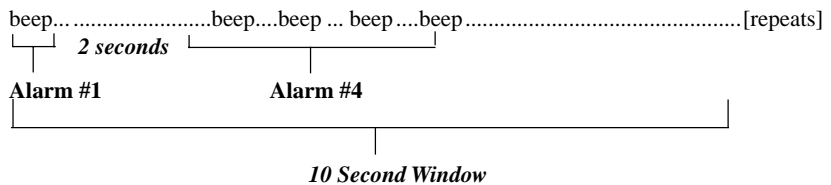

The alarm tone definitions are as follows:

Number of Beeps	Alarm Condition Name	Alarm Condition Description
1	Battery Revert	Alarm is reported when station loses AC/DC line power and reverts to battery backup. Alarm is cleared when station receives AC/DC power. Should not occur in PDR 3500.
2	PA Fail	Alarm is reported when PA fails to keyup to full output power. Alarm is cleared upon successful keyup to full power.
3	Synthesizer	Alarm is reported when either Tx or Rx synthesizers fail to lock. Alarm is cleared when both synthesizers lock.
4	Overvoltage	Alarm is reported when battery charging voltage is above +34.5 V (100 W stations), or +17.25 V (20 W stations). Alarm is cleared when voltage returns to normal range.

## Verifying Transmitter Circuitry

### Introduction

While most module faults can be detected by running the station diagnostics provided by the RSS, the following procedure provides a more traditional method of troubleshooting the transmitter circuitry. This procedure is useful in the event that the RSS is not at hand or for some reason cannot be utilized (PC malfunction, etc.)

This procedure allows the service technician to make minor adjustments and verify the proper operation of the station transmit circuitry, including:

- Exciter Module
- Power Amplifier Module
- Power Supply Module
- 2.1 MHz Reference Oscillator Circuitry
- Transmitter-related circuitry on the Station Control Module (SCM)

In general, the transmitter circuitry is exercised by injecting and measuring signals using a Motorola R2001 Communications Analyzer (or equivalent). Measured values outside the acceptable range indicate a faulty module; values within range verify proper operation of the above listed modules and circuitry.

### Required Test Equipment

The following test equipment is required to perform the procedure:

- Motorola R2001 Communications Analyzer (or equivalent)
- Telephone-style handset with PTT switch (TMN6164, or equivalent)
- In-line Wattmeter (Motorola Model S-1350, or equivalent)
- Dummy Load (50Ω, station wattage or higher)

### Verifying Transmitter Circuitry Procedure

- Step 1. Connect test equipment by performing Step 1 through 3 shown in Figure 6.
- Step 2. Connect handset to RJ-11 connector on SCM front panel, as shown. The cover plate over the SCM side of the chassis must be removed to access this connector.

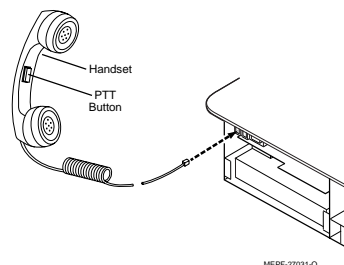

MEPF-27031-O



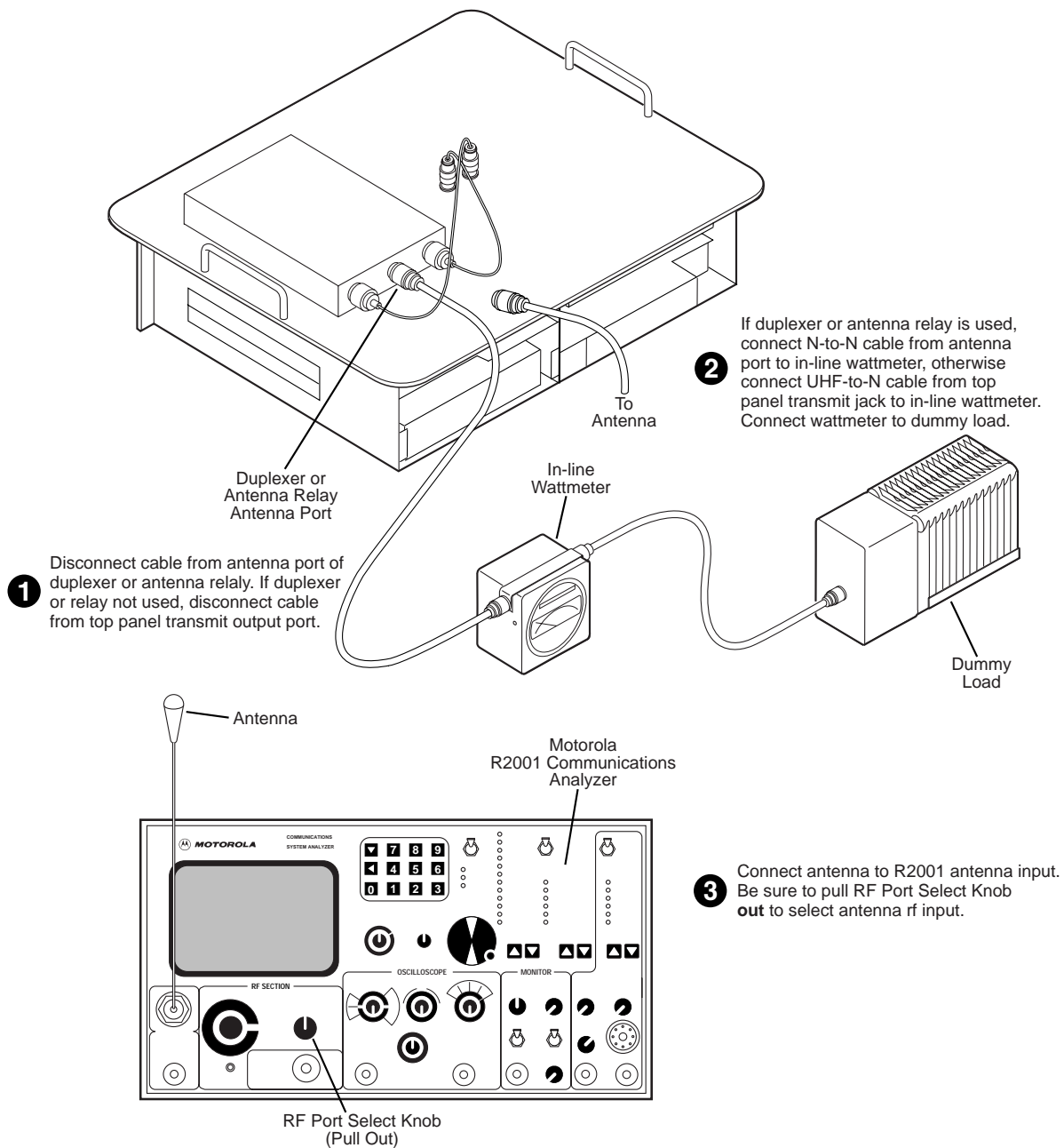

MAEPF-27032-O

**Figure 6 Test Equipment Setup for Verifying Transmitter Circuitry**

Step 3. Press the PTT button and observe the LED indicators on the Exciter Module front panel.

- If **PA Low** or **PA Fail** LED is lit, suspect the following:
  - Power Amplifier Module failure
  - Exciter Module failure
  - Loose or bad Exciter-to-PA RF cable
  - DIP switches on backplane are set for incorrect station frequency band. DIP switches should be set as described in the backplane portion of the **Module Replacement** section.
  - Faulty forward voltage, control voltage, or temperature voltage translation circuitry on backplane.
- If **TX Lock** LED is off, suspect the following:
  - Faulty Station Control Module
  - Faulty Exciter Module
  - Faulty backplane

Step 4. Measure output power by pressing the PTT button and observing the reading on the in-line wattmeter.

- If the PA output is not at the proper power (as set for the particular station), adjust the output power as described in the **Setup and Connections** section of this manual.
- If the station will not output the rated power, and the output is being measured through a duplexer or antenna relay, the duplexer could be set for the incorrect frequency, or it could be malfunctioning, or the antenna relay could be faulty. Connect the wattmeter directly to the transmit port (UHF connector) on the station top panel, bypassing the duplexer or antenna relay. If the station generates rated power directly from the PA, suspect the following:
  - Faulty duplexer or transmit frequency mismatch
  - Loose or faulty PA-to-duplexer/antenna relay cable
  - Improperly connected or faulty antenna relay

If the station still does not generate rated power, suspect the following:

- Power Amplifier Module failure
- Exciter Module failure
- Loose or faulty Exciter-to-PA RF cable
- Faulty forward voltage or control voltage translation circuitry on backplane

Step 5. If the PA power out is okay, setup R2001 for spectrum analyzer display. Press the PTT button and observe the display. The display should look similar to:

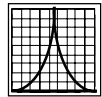

- If the display shows multiple carriers, evenly spaced about the station transmit frequency, suspect a faulty PA module.
- If the display shows a solid carrier, but off frequency, suspect the following:
  - Faulty Exciter or Station Control Module
- If the display shows a single carrier moving erratically, suspect the following:
  - Faulty Station Control Module
  - Faulty Exciter Module
  - Faulty PA Module

Step 6. If the display is okay, setup R2001 to display modulation. Using the handset, push the PTT button and speak into the mouthpiece. Verify that the display shows:

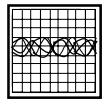

- If the proper display is not obtained, suspect faulty SCM or Exciter Module

Step 7. Set the R2001 for GEN/MON MTR. Press the PTT button and speak loudly into the mouthpiece to cause maximum deviation. Display should read  $\pm 5$  kHz maximum.

- If the proper display is not obtained, suspect faulty SCM or Exciter Module

Step 8. This completes the **Verifying Transmitter Circuitry** test procedure. If all displays and measurements are correct, the transmitter circuitry may be considered to be operating properly.

- Remove test equipment.
- Restore the station to normal service.
- Return to the trouble shooting flow chart to resume the troubleshooting sequence.

## Verifying Receiver Circuitry

### Introduction

While most module faults can be detected by running the station diagnostics provided by the RSS, the following procedure provides a more traditional method of troubleshooting the receiver circuitry. This procedure is useful in the event that the RSS is not at hand, or, for some reason, cannot be utilized (PC malfunction, etc.)

This procedure allows the service technician to make minor adjustments and verify the proper operation of the station receive circuitry, including:

- Receiver Module
- Power Supply Module
- 2.1 MHz Reference Oscillator Circuitry
- Receiver-related circuitry in the Station Control Module (SCM)

In general, the receiver circuitry is exercised by injecting and measuring signals using a Motorola R2001 Communications Analyzer (or equivalent). Measured values outside the acceptable range indicate a faulty module; values within range verify proper operation of the above listed modules and circuitry.

### Required Test Equipment

The following test equipment is required to perform the procedure:

- Motorola R2001 Communications Analyzer (or equivalent)
- Telephone-style handset with PTT switch (TMN6164, or equivalent)
- RJ-11 to BNC cable
- Dummy Load (50 $\Omega$ , station wattage, or higher)

### **IMPORTANT!**

---

**If the station operates as a repeater, the transmit output from the station must be connected to a dummy load to prevent over-the-air broadcast during receiver testing.**

---

## Verifying Receiver Circuitry Procedure

Step 1. Connect test equipment by performing Step 1 through 3 shown in Figure 7.

**NOTE:** The cover plate over the SCM side of the chassis must be removed to perform these tests.

Step 2. Disable PL and carrier squelch by repeatedly pressing the **PL/CSQ/Off** button until receiver noise is heard through the handset (or external speaker). Refer to Figure 5 for the location of the **PL/CSQ/Off** button. If no audio is heard, suspect the following:

- Faulty Receiver Module
- Faulty Station Control Module
- R2001 is outputting a carrier signal

Step 3. Set R2001 to generate a 0.5  $\mu$ V (-13 dBm) FM signal at the *PDR 3500* receiver frequency, modulated by a 1 kHz tone at 3 kHz deviation. The 1 kHz tone should be audible through the handset (or external speaker). If no audio is heard, suspect the following:

- Faulty Station Control Module (2.1 MHz reference)
- Faulty Receiver Module
- Faulty antenna-to-Receiver preselector RF cable
- Faulty R2001-to-station RF cable
- Duplexer/station receive frequency mismatch, or faulty duplexer

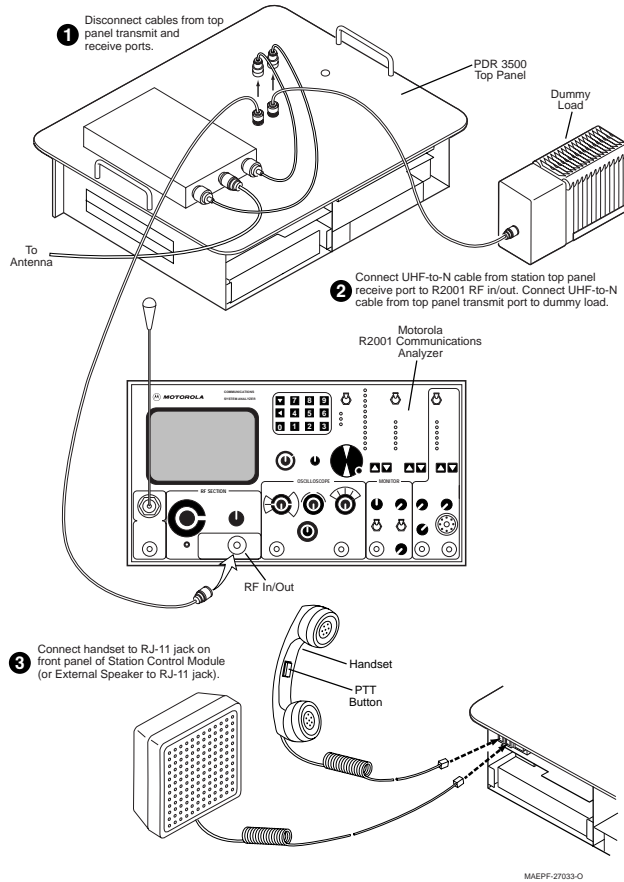

MAEPF-27033-O

**Figure 7 Test Equipment Setup for Verifying Receiver Circuitry**

Step 4. If audio is heard, connect the **HANDSET RJ-11** jack to the Oscilloscope input BNC connector, as shown below.

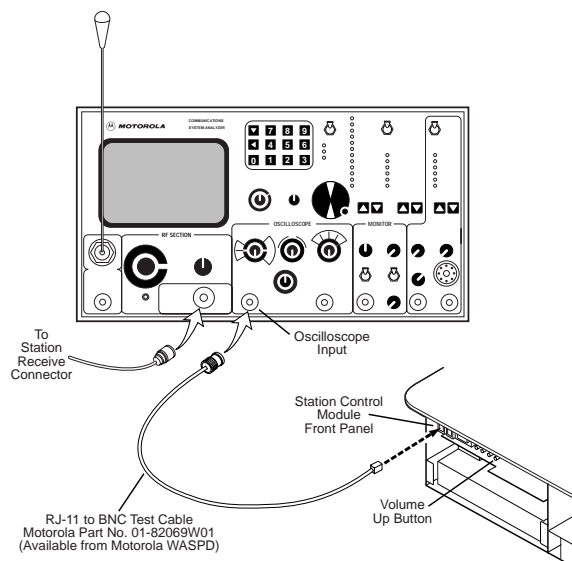

MAEPF-27034-O

Step 5. Use the **Volume Up** button to increase the volume to maximum. Measure the audio level using the R2001.

- Audio level should measure approximately 0.75 to 1.5 V p-p. If not, suspect faulty SCM.

Step 6. Change R2001 injection signal to

- VHF: 0.25  $\mu$ V (-119 dBm)
- UHF: 0.35  $\mu$ V (-116 dBm).

Step 7. Measure the receiver 12 dB SINAD sensitivity. The value should read 12 dB, or greater. If not, tune the preselector (VHF and UHF only) and re-check 12 dB SINAD. If 12 dB SINAD cannot be achieved, suspect the following:

- Damaged cable from top panel receive port to preselector
- Faulty receiver
- Excessive loss in the R2001-to-station RF cable

**NOTE:** To measure 12 dB SINAD, the station must be programmed for mixed mode Analog/Digital operation. Incorrect reading will result if programmed for Digital Only operation.

**NOTE:** For VHF and UHF stations only, refer to **5. Preselector Field Tuning Procedure** in this section. Procedures for tuning the receiver preselector are described.

Step 8. If the station is configured with a duplexer, continue with Step 9 to test the duplexer's performance. If the station is **not** configured with a duplexer, go to Step 16.

Step 9. Steps 9 through 13 describe a method of measuring the effect of insertion loss from the duplexer on receiver sensitivity. Connect the dummy load to the station's top panel receive port through a capacitive coupler (isolated T). Connect the R2001 to the isolated side of the coupler. (See Figure 8.)

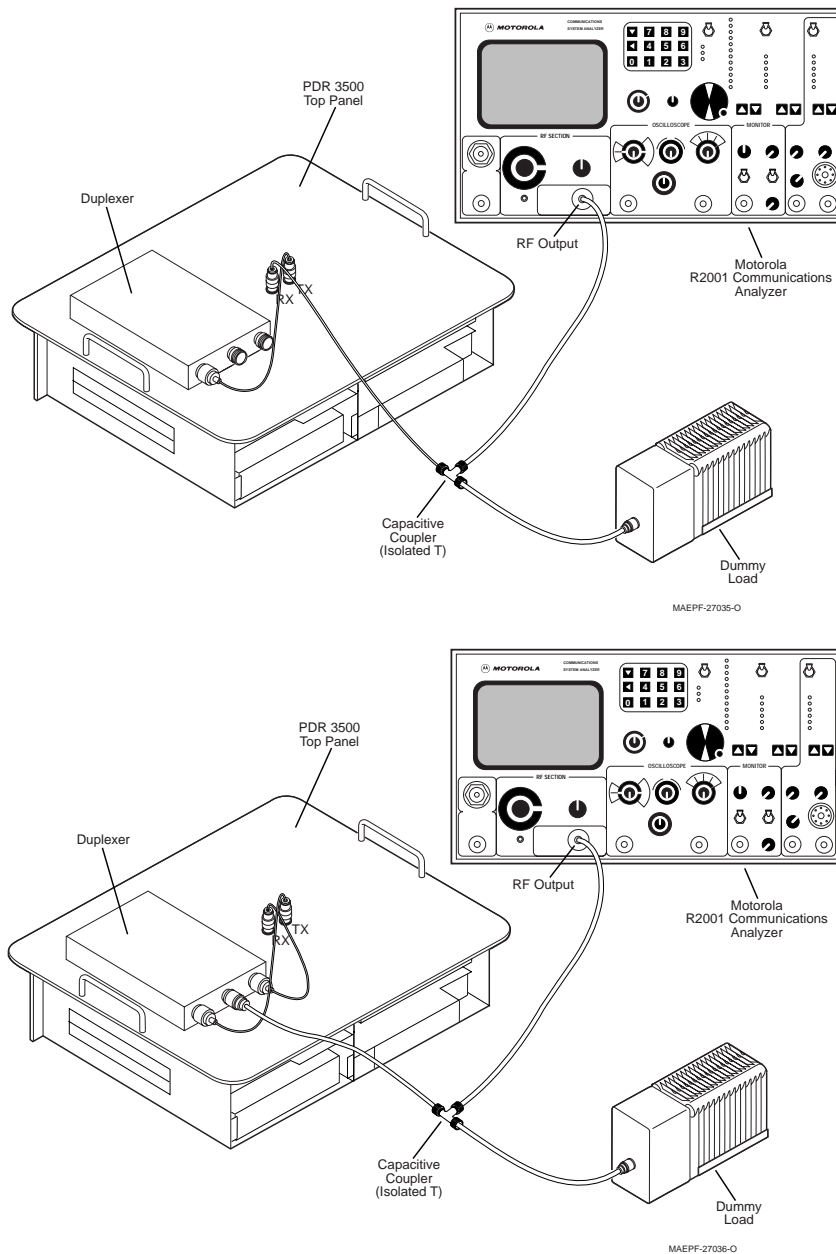

**Figure 8 A. Coupled receiver connection. (Top) B. Coupled duplexer connection. (Bottom)**

Step 10. Disable the transmitter by holding the **Shift** button and then pressing the **Access Disable** button on the Station Control Module, as shown in Figure 9. When the transmitter is disabled, the yellow Access disable light on the SCM will flash. **This step is very important.** With the transmitter disabled, the PA Full LED on the Exciter Module should not light, even when the station is receiving.



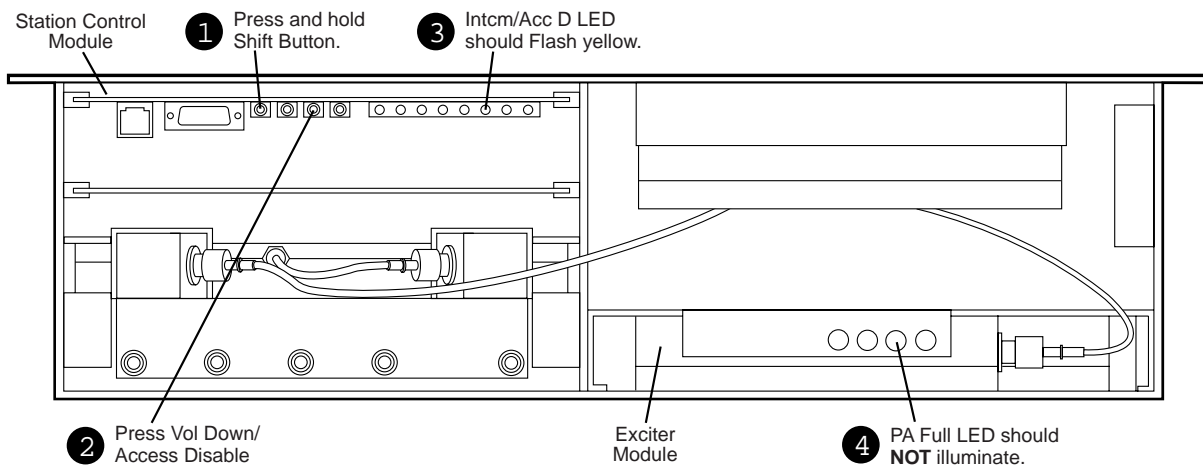

MAEPF-27037-O

**Figure 9 Disabling the Transmitter**

Step 11. Measure the 12dB SINAD sensitivity and make a note of the level. This level will serve as a baseline for the receiver sensitivity. If 12 dB SINAD cannot be achieved, suspect the following:

- Test configuration used does not match that shown in Figure 8B.
- Excessive loss in the coaxial cables or coupler.

Step 12. Remove the cable connecting the coupler to the top panel receive port. Connect the coupler to the duplexer's antenna port. Connect the duplexer's receive port to the station's top panel receive port, as in normal station operation. (See Figure 8B.)

Step 13. Measure the 12 dB SINAD once again, and note the result. The difference between this 12 dB SINAD level and the level measured in Step 11 reflects the insertion loss of the duplexer. The difference should be no greater than approximately

- VHF: 1.3 dB
- UHF: 1.6 dB

If the difference is greater, suspect the following:

- Duplexer receive and transmit ports are reversed
- Loose or damaged cables between the duplexer and the station
- Station receive frequency does not match the duplexer receive frequency. Use a different frequency or replace the duplexer. (Field tuning of duplexers is **not** recommended.)

Step 14. Steps 14 and 15 will test the effect of duplexer quieting on receive sensitivity. Re-enable the transmitter by holding down the **Shift** button again and pressing the **Access Disable** button on the SCM. The following lights should indicate that the station is now operating as a repeater:

- Yellow Access Disable light stops flashing
- PA Full LED on the Exciter Module lights when the station is receiving.

Step 15. Test the 12 dB SINAD sensitivity. Depending on the duplexer frequency spacing, this level should be no more than 1 to 2 dB greater than the Step 13 reading (with the transmitter disabled). If the reading is greater than 1 to 2 dB, the station transmit frequency does not match the duplexer receive frequency. Use a different frequency or replace the duplexer. (Field tuning of duplexers is **not** recommended.)

Step 16. If the station is not digital-capable, the **Verifying Receiver Circuitry** test procedure is complete. The receiver circuitry is considered to be operating properly if all displays and measurements are correct.

1. Remove the test equipment.
2. Restore the station to normal service.
3. Return to the troubleshooting flow chart to resume the troubleshooting sequence.

If the station is digital-capable, continue with the **Digital Only** portion of the **Verifying Receiver Circuitry** test procedure.

## Verifying Receiver Circuitry (Digital-Capable Stations)

### Introduction

While most module faults can be detected by running the station diagnostics provided by the RSS, the following procedure provides a more traditional method of troubleshooting the receiver circuitry.

This procedure allows the service technician to make minor adjustments and verify the proper operation of the station receive circuitry, including:

- Receiver Module
- Power Supply Module
- 2.1 MHz Reference Oscillator Circuitry
- Receiver-related circuitry in the Station Control Module (SCM)

The transmitter circuitry is exercised by injecting and measuring signals using a Motorola R2670 Communications Analyzer (or equivalent), and analyzing the Bit Error Rate using the RSS. Measured values outside the acceptable range indicate a faulty module; values within range verify proper operation of the above modules and circuitry.

## Required Test Equipment

The following test equipment is required to perform the procedure:

- Motorola R2670 Communications Analyzer with *ASTRO CAI* Option (or equivalent)
- PC running Radio Service Software (RSS) program
- Female N-type to Female N-type coaxial cable
- Dummy Load (50 $\Omega$ , station wattage, or higher). Required for repeater stations only.

## **IMPORTANT!**

---

**If the station operates as a repeater, the transmit output from the station must be connected to a dummy load to prevent over-the-air broadcast during receiver testing.**

---

- Step 1. Proceed to *ASTRO Bit Error Rate Report* (located in Chapter 4 of the *RSS User's Guide*, part number 68P81085E35). Follow the instructions for setting up the test equipment and initiating a BER report using the RSS.
- Step 2. If the BER reading is above 5%, suspect the following:
  - Faulty Station Control Module (2.1 MHz reference)
  - Faulty Receiver Module
  - Faulty antenna-to-receiver preselector RF cable
  - Faulty top panel-to-preselector RF cable
  - Faulty R2670-to-station RF cable
- Step 3. If you are injecting RF directly into the top panel receiver port, change the R2670 injection signal level to:
  - VHF: 0.25  $\mu$ V (-119 dBm)
  - UHF: 0.35  $\mu$ V (-116 dBm)

If you are injecting RF through a duplexer, change the R2670 injection signal level to:

- VHF: 0.29  $\mu$ V (-117.7 dBm)
- UHF: 0.43  $\mu$ V (-114.4 dBm)

**NOTE:** For VHF and UHF stations only, refer to **5. Preselector Field Tuning Procedure** in this section, for procedures to tune the receiver preselector.

Step 4. Note the receiver BER reading. The BER reading should be 5% or less. If not, and if a duplexer is being used, repeat the BER test, bypassing the duplexer. If the BER is 5% or less after bypassing the duplexer, the station frequencies do not match the duplexer frequencies, or the duplexer-to-top panel cables are faulty.

If the BER, as tested straight into the top panel, is greater than 5%, tune the preselector and re-check the BER reading. If a reading of 5%, or less, cannot be achieved, replace the Receiver Module.

Step 5. This completes the **Verifying Receiver Circuitry** test procedure. If all displays and measurements are correct, the receiver circuitry may be considered to be operating properly.

1. Remove test equipment.
2. Restore the station to normal service.
3. Return to the trouble shooting flow chart to resume the troubleshooting sequence.

## Wiring Diagram

Please refer to Figure 10 for a conceptual line drawing of the motherboard, modules, and other components set flat outside of the chassis and properly interconnected.

Please refer to Figure 11 on page 25 for a detailed diagram of the connections from the AC inlet connector to the power supply and chassis ground.

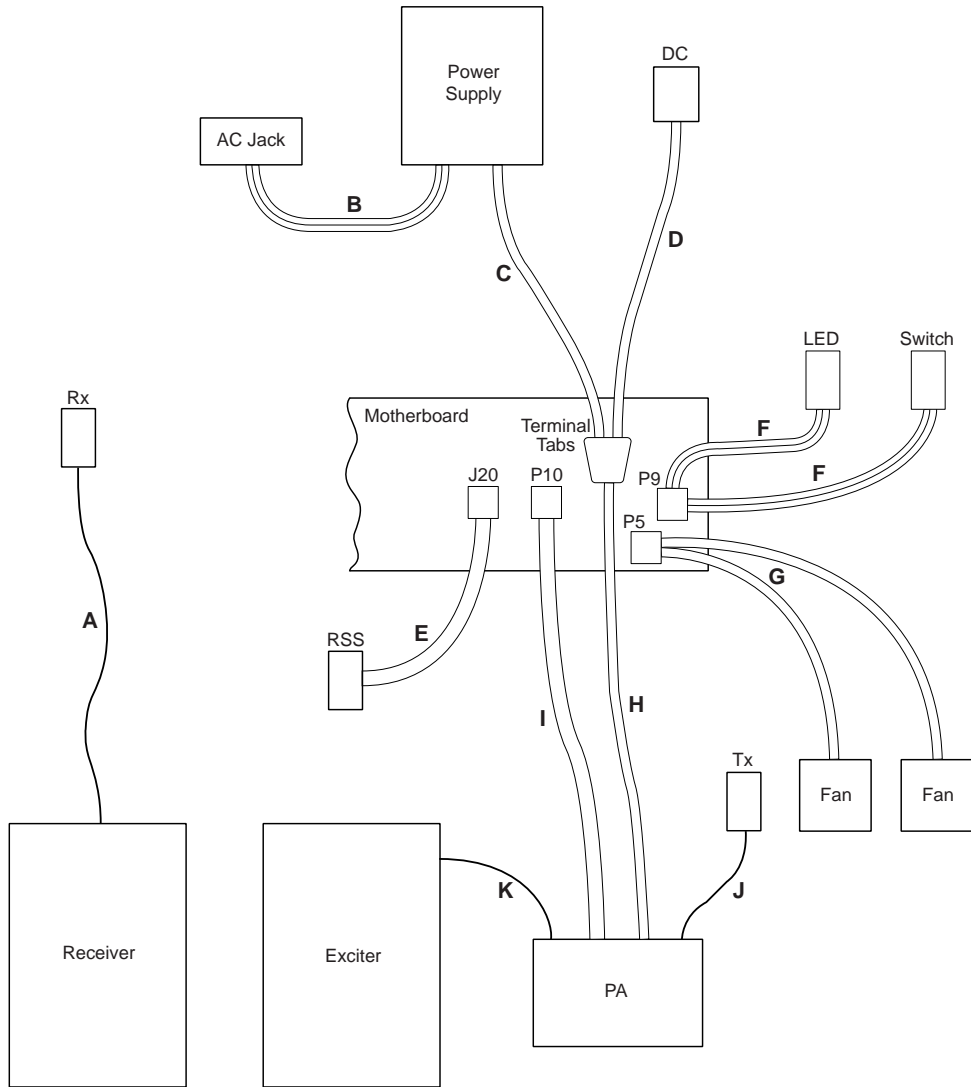

MAEPF-27080-O

**Figure 10 Interconnect Diagram**

Reference	From	To	Description
A	Top panel UHF	Receiver mini-UHF	Receive RF coaxial cable
B	Top panel AC connector	Power supply terminals H, N, GND	120/240 VAC to power supply
C	Power supply terminals POS, NEG	Backplane terminals WHT, BLK	14 VDC from power supply
D	Top panel DC connector	Backplane terminals BLU, BLK	14 VDC input to station
E	Top panel DB-9 connector	Backplane connector J20	RSS interface ribbon cable assembly
F	Top panel LED/Switch	Backplane Molex P5/P9	LED/Switch assembly
G	Chassis cooling fans	Backplane 3-pin Molex P5	Cooling fan assembly
H	Backplane terminals RED, BLK	PA 14 VDC input	14 VDC to PA
I	Backplane connector P10	PA	Control/feedback ribbon cable
J	PA mini-UHF	Top panel UHF	Transmit RF coaxial cable
K	Exciter mini-UHF	PA	RF drive coaxial cable

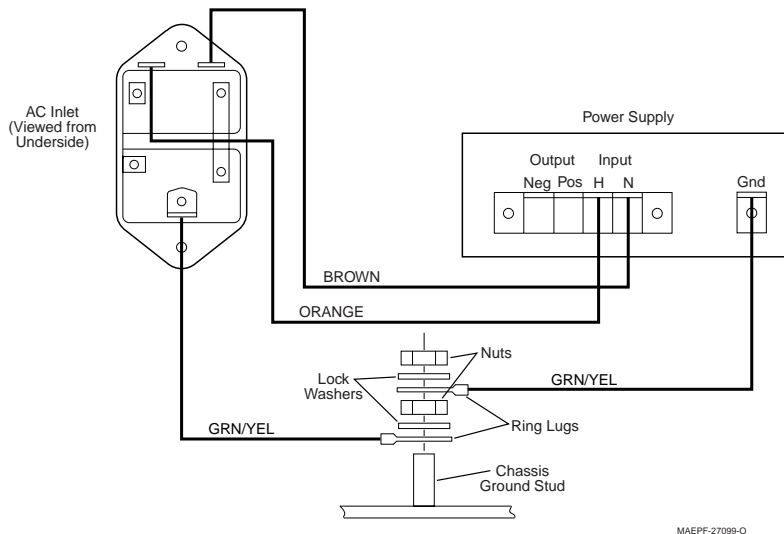

**Figure 11 Chassis Ground Wiring Diagram**

## Module Replacement Procedures

Station modules suspected of being faulty must be replaced with modules known to be in good condition in order to restore the station to proper operation. The following procedures provide instructions for replacing each of the station modules and performing any required post-replacement adjustments or programming.

## General Replacement Information



**WARNING:** When wearing a Conductive Wrist Strap, be careful near sources of high voltage. The good ground provided by the wrist strap will also increase the danger of lethal shock from accidentally touching high voltage sources.

## Anti-Static Precaution

The station circuitry contains many C-MOS and other static-sensitive devices. When servicing the equipment, you must take precautionary steps to prevent damage to the modules from static discharge. Complete information on prevention of static protection is provided in Motorola publication number 68P81106E84, available through the Accessories and Aftermarket Division.

Some additional precautions are as follows:

- A wrist strap (Motorola part number RSX4015A, or equivalent) should be worn while servicing the equipment to minimize static buildup.



**CAUTION:** DO NOT insert or remove station modules with power applied. This may result in damage to the modules.

- Do not insert or remove modules with power applied. Always turn off the station by unplugging the AC and DC cords from the top panel before inserting or removing modules.
- All spare modules should be kept in a conductive bag for storage and transporting. When shipping modules to the repair depot, always pack them in conductive material.

## Care of Gold-Plated Connector Contacts

The connectors between the modules and the station backplane board are made with gold-plated card edge connector contacts to provide maximum reliability. Gold-plated materials do not form a non-conductive oxide layer and therefore should not require cleaning under normal conditions.

When the modules have been subjected to many extraction/insertion cycles, or if the station is operated in a dusty environment, the contacts may require cleaning. **Do not** use an eraser or any type of abrasive substance to clean either the module card edge connectors, or the backplane connector contacts.

If the cleaning of gold-plated contacts is required, use a soft cloth dampened with alcohol to lightly wipe the contacts. Be sure not to touch the contact surfaces with your fingers; finger oils and salts can contaminate the contact surfaces.

## Power Down Station Before Removing/ Inserting Modules

Before removing or inserting a module into the station chassis and engaging the backplane connector, be sure to turn off the station power by unplugging the AC or DC power cord, or both.

## Validating Repairs

After replacing a faulty module with a module that is known to be in good condition, perform the following tests to validate the repair.

- If the faulty module was detected as the result of running station diagnostics via the RSS, run the diagnostics again after the repair is made to ensure that the replacement module passes all diagnostic tests.
- If the faulty module was detected by an operational failure, perform the operation to ensure that the repair corrected the reported or detected failure.

## Module Replacement

This section discusses the replacement of each of the PDR 3500's modules and related requirements and considerations.

## Station Control

### *Before Removing the Old Station Control Module*

A new SCM contains settings in a codeplug (EEPROM). Those settings can be configured, using the RSS, after the module has been installed.

If the old SCM is capable of communicating with the RSS, the old codeplug can be read from the SCM and saved to disk to be programmed into the new SCM. This is described in the **Setup and Connections** section of this manual, and in the *RSS User's Guide* (68P81085E35).

If the old SCM is incapable of communicating with the RSS, an archival codeplug (one saved on disk) can be used to program the new SCM. If an archival codeplug is unavailable, the new codeplug will have to be manually configured after installation.

### **Physical Replacement of the Station Control Module**

1. Turn off the station's power by unplugging the AC and DC power cords from the top panel.
2. Remove the 8 Phillips screws from the edges of the station's top panel and lift the chassis out of the case.
3. Remove the cover plate on the left end of the front of the station by removing two Torx screws from the front of the plate. Remove the four Phillips screws from the side and bottom edges of the plate.
4. Pull out the old Control Module by gripping behind its DB-9, RJ-11, and RJ-45 connectors, distributing pressure equally among the connectors.
5. Insert the new module. Make sure it is in the cardguides; push it firmly into the chassis until it seats into the card-edge connectors on the backplane. (**Do not** slam the board against the backplane or push any harder than necessary to seat the connectors.)
6. If desired, power up the station while it is still out of the case to make sure the module is securely in place. If the LEDs do not light, are dim, or flash rapidly, one or more modules are not seated properly. Unplug the station before continuing to the next step.
7. Reassemble the station by reversing steps 2 and 3.

### **After Installing the New Station Control Module**

1. If the codeplug from the old SCM was saved to disk, or if an archival codeplug exists on disk, it should be programmed into the new SCM.



If no preexisting codeplug is available, the new codeplug must be configured manually using the RSS. See the **Setup and Connections** section of this manual or the *RSS User's Guide* (68P81085E35) for details.

2. Perform the following alignment procedures as described in the *RSS User's Guide* (68P81085E35) or the **Setup and Connections** section of this manual, or both.
  - Reference Oscillator Calibration
  - Squelch Adjust
  - Power Output
  - Tx Deviation Gain Adjust
  - Reference Modulation
  - RSSI Calibrate

For Wireline-equipped stations only:

- Tx Wireline
- Rx Wireline

For ASTRO stations only:

- Simulcast/ASTRO Launch Time Offset

For 6809 Trunking stations only:

- TDATA

## Wireline

### Physical Replacement of the Wireline Module

1. Turn off the station's power by unplugging the AC and DC power cords from the top panel.
2. Remove the eight Phillips screws from the edges of the station's top panel and lift the chassis out of the case.
3. Remove the cover plate on the left end of the front of the station by removing two Torx screws from the front of the plate. Remove the four Phillips screws from the side and bottom edges of the plate.
4. Pull out the old Wireline Module by gripping its front, right corner (where there are no parts on the board).
5. Set all jumpers on the replacement board to match those on the faulty board. These include the following:
  - Input/output impedance matching jumpers

- Two-wire/four-wire select jumper
  - DC remote control selection jumpers
6. Insert the new module. Make sure it is in the cardguides; push it firmly into the chassis until it seats into the card-edge connectors on the backplane. (**Do not** slam the board against the backplane or push any harder than necessary to seat the connectors.)
  7. If desired, power up the station while it is still out of the case to make sure the module is securely in place. The LEDs on the Wireline should blink rapidly, indicating that firmware is transferring from the SCM to the Wireline Module. When the blinking stops, the transfer is complete.  
  
If any of the LEDs do not light or are dim, one or more of the modules are not seated properly. Unplug the station before continuing to the next step.
  8. Reassemble the station by reversing Steps 2 and 3.

### **After Installing the New Wireline Module**

Perform the following alignment procedures as described in the *RSS User's Guide* (part number 68P81085E35):

- Rx Wireline
- Tx Wireline

### ASTRO Modem Card/ V.24 Interface Card

#### **Physical Replacement of the Card**

1. Remove the Wireline Module as described above.
2. Unplug the faulty ASTRO Modem Card or the V.24 Interface Card from the Wireline board by pressing the mounting posts through the back of the board.

Install the replacement card by pressing it onto the Wireline board and locking all mounting posts and connectors.

3. Re-install the Wireline Module as described above.

### **After Installing the New Card**

No alignments or adjustments are required. The card is configured by the Station Control Module on power-up.

### Receiver

#### **Physical Replacement of the Receiver Module**

1. Turn off the station's power by unplugging the AC and DC power cords from the top panel.
2. Remove the eight Phillips screws from the edges of the station's top panel and lift the chassis out of the case.

3. Remove the cover plate on the left end of the front of the station by removing two Torx screws from the front of the plate. Remove the four Phillips screws from the side and bottom edges of the plate. Remove two more Phillips screws from the bottom of the chassis under the preselector.
4. A coaxial cable runs from the receiver's preselector, through the center wall of the chassis, and to the top panel UHF connector. Disconnect the cable from the preselector and push the loose end of the cable through the center wall so that it is completely clear of the receiver.
5. Pull the old receiver out by gripping the tabs protruding past each end of the preselector.
6. Insert the new module. Make sure it fits under the metal rails inside the chassis. Push it firmly into the chassis until it seats into the card-edge connectors on the backplane. (**Do not** slam the board against the backplane or push any harder than necessary to seat the connectors.)
7. If desired, power up the station while it is still out of the case to make sure the module is securely in place.  
  
If any of the LEDs do not light, are dim, or flash rapidly, one or more of the modules are not seated properly.
8. For VHF and UHF stations, tune the preselector using the procedure in the Maintenance subsection, **Preselector Field Tuning Procedure**. Before continuing to the next step, be sure to unplug the station.
9. Feed the coaxial cable detached in Step 3 back through the opening in the center wall of the chassis and reconnect it to the mini-UHF connector on the preselector.
10. Reassemble the station by reversing Steps 2 and 3.

### **After Installing the New Receiver Module**

Perform the following alignment procedures as described in the *RSS User's Guide* (part number 68P81085E35), or in the RSS section of this manual, or in both:

- Squelch Adjust
- RSSI Calibrate

Preselector tuning is required for proper performance of the Receiver Module and it should have been performed when installing the module, as described under "Physical Replacement of the Receiver Module." If the tuning was not performed when the module was installed, perform it now.

## Exciter

### Frequency Band Considerations

When replacing the Exciter Module, it is important to remember the frequency-sensitive nature of the Exciter/Power Amplifier combination. The Exciter and the PA must match according to the model breakdown table in this manual. If an Exciter with a new frequency band is being installed, the corresponding PA must be installed, as described in the Power Amplifier subsection of “Module Replacement.”

### Physical Replacement of the Exciter Module

1. Turn off the station’s power by unplugging the AC and DC power cords from the top panel.
2. Remove the eight Phillips screws from the edges of the station’s top panel and lift the chassis out of the case.
3. Disconnect the coaxial cable running to a mini-UHF connector at the front of the Exciter.
4. Tilt the chassis up on its back edge; then, from the bottom of the chassis, remove the six Phillips screws holding the Exciter’s mounting plate. Slide the mounting plate out of the front of the chassis.
5. Pull out the old Exciter Module by gripping behind the mini-UHF connector and pulling gently.
6. Insert the new module. Make sure it is flat on the bottom of the chassis. Push it firmly into the chassis until it seats into the card-edge connectors on the backplane. (**Do not** slam the board against the backplane or push any harder than necessary to seat the connectors.)
7. If desired, power up the station while it is still out of the case to make sure the module is securely in place. If the LEDs do not light, are dim, or flash rapidly, one or more modules are not seated properly. Unplug the station before continuing to the next step.
8. Reassemble the station by reversing Steps 2 through 4.

### After Installing the New Exciter Module

Perform the following alignment procedures as described in the *RSS User’s Guide* (part number 68P81085E35):

- Tx Deviation Gain Adjust
- Reference Modulation

For ASTRO Simulcast systems only:

- ASTRO/Simulcast Launch Time Offset

## Power Amplifier

### Frequency Band Considerations

When replacing the Power Amplifier, it is important to remember the frequency-sensitive nature of the Exciter/Power Amplifier combination. The Exciter and the PA must match according to the model breakdown table in this manual. If a PA with a new frequency band is being installed, the corresponding Exciter must be installed, as described in the Exciter subsection of “Module Replacement.”

Of equal importance, the PDR 3500 motherboard contains circuitry which translates between the Exciter from the original Quantar and the PA from the Spectra™ mobile radio. Since the translations depend upon the frequency band of the Exciter and the PA, this circuitry is also frequency-sensitive.

The DIP switches on the motherboard must be set according to the frequency of the station in order for the proper translation path to be selected. The DIP switch settings can remain intact if

- The band of the new PA matches the one being replaced, and
- The Exciter is not being changed.

If the PA band or the Exciter band is being changed, the DIP switches must be configured to match the new frequency of the PA and Exciter. Detach the motherboard from the chassis and set the switches as described in the Backplane subsection of “Module Replacement.”

### Physical Replacement of the Power Amplifier

1. Turn off the station’s power by unplugging the AC and DC power cords from the top panel.
2. Remove the eight Phillips screws from the edges of the station’s top panel and lift the chassis out of the case.
3. Remove the four Phillips screws from the front, right quadrant of the top panel to release the PA. When removing the fourth screw, support the PA inside the chassis to prevent it from falling.
4. Disconnect all four cables between the PA and the station:
  - a. Unplug the red and black power cable from the PA.
  - b. Unscrew the mini-UHF connector from the PA.
  - c. To remove the PA ribbon cable connector, remove the two Torx screws holding the metal clip over the connector. Pull the connector loose from the PA.
  - d. Unscrew the mini-UHF connector on the remaining cable from the front of the Exciter.

5. Reconnect all four cables removed in Step 4. The ribbon cable connector is keyed so it cannot be attached incorrectly. Remember to reattach the metal clip over the ribbon cable connector.
6. Take the sheet of black thermal conductive film that was between the old PA and the chassis and place it on the new PA.
7. Place the PA in the chassis and line up the screw holes in the PA and the thermal film with the holes in the top panel of the chassis. (It may be useful to insert a pencil, pen, or small screwdriver through the screw holes in the top panel to aid in aligning the holes in the conductive film with those in the PA.)
8. While holding the PA with one hand, start two or more Phillips screws in the top panel to hold the PA in place. Insert the remaining screws and tighten all four.
9. Place the chassis back in the case and secure it with the eight Phillips screws around the top panel.

### **After Installing the New Power Amplifier**

Perform the following alignment procedures as described in the *RSS User's Guide* (part number 68P81085E35), or the **Setup and Connections** section of this manual, or both.

- Power Output

### Power Supply

#### **Physical Replacement of the Power Supply**

1. Turn off the station's power by unplugging the AC and DC power cords from the top panel.
2. Detach the backplane from the chassis as described in Steps 1 through 7 of the Backplane subsection of "Module Replacement."
3. Remove the four Phillips screws holding the Power Supply to the top panel of the chassis. Pull the PS out of the chassis.
4. Disconnect all five wires from the Power Supply.
5. Reconnect the wires to the new Power Supply as follows:
  - Green to GND
  - Orange to the "H" INPUT
  - Brown to the "N" INPUT
  - White to the "POS" OUTPUT
  - Black to the "NEG" OUTPUT.
6. While holding the PS with one hand, start two or more Phillips screws in the top panel to hold the Power Supply in place. Insert the remaining screws and tighten all four.

7. Finish reassembling the station as described in Steps 8 through 12 of the Backplane subsection of “Module Replacement.”

## Backplane

### Before Installing the New Backplane

The PDR 3500 motherboard contains circuitry which translates between the Exciter from the original Quantar and the PA from the Spectra™ mobile radio. Since the translations depend upon the frequency band of the Exciter and the PA, this circuitry is also frequency-sensitive. For the proper translation path to be selected, the DIP switches located on the motherboard must be set based on the frequency band of the station.

Before installing the new Backplane, set its DIP switches according to Table 10.

**Table 10 Motherboard DIP Switch Settings**

Exciter Frequency Band	PA Model	Switch 1	Switch 2
VHF Range 1	PLD7981	OFF	OFF
VHF Range 2	PLD7981	ON	OFF
UHF Range 1	PLE9367	OFF	ON
UHF Range 2	PLE9369	ON	ON

### Physical Replacement of the Backplane

1. Turn off the station’s power by unplugging the AC and DC power cords from the top panel.
2. Remove the eight Phillips screws from the edges of the station’s top panel and lift the chassis out of the case.
3. Remove the cover plate on the left end of the front of the station by removing two Torx screws from the front of the plate and four Phillips screws from the side and bottom edges of the plate.
4. Pull the Station Control Module and Wireline Module until they disengage from their respective backplane connectors. The modules need not be completely removed from the chassis.
5. On the back of the chassis, remove the six Phillips screws holding the backplane in place.
6. Slowly, but firmly, pull the bottom edge of the backplane away from the chassis. Continue pulling until the 80-pin card edge connectors dislodge from the Receiver and Exciter modules. Then pull the backplane down and away from the top panel of the chassis.
7. Lay the backplane flat behind the station, and remove all the attached wires.
8. If the dip switches on the new backplane have not been set to match the PA/Exciter combination of the station, set them now according to Table 10.

9. Lay the new backplane behind the station, and attach all the wires as shown in Figure 10: Interconnect Diagram.
10. Hold the backplane in position behind the chassis. Ensure the wires from the backplane do not bind against the Power Supply. Slide the top of the board toward the chassis top panel, making sure the two RJ-45 connectors fit into their cutouts.
11. Hold the Receiver Module from the front of the chassis, and press the bottom center of the backplane into place against the chassis. Snap the 80-pin connectors onto the Receiver and Exciter.
12. While holding the top right portion of the backplane against the chassis, press the Control Module, and then the Wireline Module, into the chassis from the front, until they snap into the backplane.
13. Using the six Phillips screws with lock washers, secure the backplane to the chassis.
14. Finish reassembling the station by reversing Steps 2 and 3.

### **After Installing the New Power Amplifier**

Perform the following alignment procedures as described in the *RSS User's Guide* (68P81085E35), or the **Setup and Connections** section of this manual, or both:

- Power Output

Using the RSS, run a complete battery of diagnostics to exercise all boards and modules.

### **Preselector Field Tuning Procedure**

The VHF and UHF Receiver Modules comprise a circuit board and a preselector assembly. Both are secured in a slide-in module housing.

The preselector assembly is a 3-pole (UHF) or a 5-pole (VHF) bandpass filter, equipped with tuning slugs to adjust the passband corresponding to the operating frequencies of the station. The preselector assembly must be field-tuned if replaced in the field, or if the station operating frequency (or frequencies) is (are) modified. The tuning procedure follows.

### **IMPORTANT!**

**Tuning for best SINAD response DOES NOT result in optimum tuning of the preselector assembly. You must use this field-tuning procedure to obtain optimum preselector performance.**



## Required Test Equipment

The following test equipment is required to properly tune the preselector assembly:

- RF Signal Generator: Motorola R2600 Communications Analyzer, R2001 Communications Analyzer (see note), or HP8656A signal generator (or equivalent)
- Dip/Peak Monitor: HP435B Power Meter (or equivalent) with HP8484A sensitive power head, Boonton Model 92E with BNC input, or R2001/R2600, using the spectrum analyzer function.
- Torque Driver, capable of delivering 12 in. – lb. of torque, and 10 mm deep well socket.
- Tuning probe: Motorola Part number 0180763D22, part of TRN7799A tuning kit.
- Flat-blade screwdriver

**NOTE:** The R2600 Communications Analyzer can both generate and measure simultaneously. The R2001 may be used for either the generator or monitor function, but not both simultaneously. When using the R2001 as a signal generator, RF signal **must** be taken from the antenna port.

## VHF Tuning Procedure

### Calculating Proper Alignment Frequency

Use one of the following two methods to calculate the alignment frequency to be generated by the signal generator.

For stations with a **single receive frequency**, calculate the frequency of the alignment signal as follows:

- Step 1. From the site documentation or the RSS, determine the station receive frequency.
- Step 2. If the frequency is  $\leq 148$  MHz (Range 1) or  $\leq 156$  MHz (Range 2), subtract 250 kHz. Otherwise, note the actual frequency.

**Example:** If the station receive frequency is 134.575 MHz (Range 2), subtract 250 kHz, since the frequency is less than 143 MHz.

$$134.575 \text{ MHz} - 250 \text{ MHz} = 134.325 \text{ MHz}$$

Step 3. If Receiver Module is **Range 1**, determine the alignment frequency as follows:

If the frequency (from Step 2) is < 134 MHz, then the alignment frequency = 133.75 MHz.

If the frequency (from Step 2) is > 152 MHz, then the alignment frequency = 152 MHz.

Otherwise, use the actual frequency from Step 2.

Step 4. If the Receiver Module is **Range 2**, determine the alignment frequency as follows:

If the frequency (from Step 2) is < 152 MHz, then the alignment frequency = 151.75 MHz.

If the frequency (from Step 2) is > 172 MHz, then the alignment frequency = 172 MHz.

Otherwise, use the actual frequency from Step 2.

For stations with **multiple receive frequencies**, calculate the frequencies of the alignment signal as follows:

Step 1. From the site documentation, or the RSS, note the receive frequency for each channel supported by the station.

Step 2. Calculate a midpoint frequency as follows:

$$F_{\text{mid}} = (F_{\text{highest}} + F_{\text{lowest}}) \div 2$$

Step 3. Using  $F_{\text{mid}}$  in place of the station receive frequency, perform Step 2 through Step 4 above.

## Preparing Equipment

Step 1. Make sure the Receiver Module (with the Preselector Assembly) is installed in a functional PDR 3500.

Step 2. Remove the chassis from its case by removing the eight Phillips screws from the edges of the station's top panel.

Step 3. Remove the two Torx screws from the Receiver Module front panel and remove the four Phillips screws. Remove the panel.

Step 4. De-tune the preselector as follows:

If the alignment frequency (calculated in the previous section) is **greater** than 148 MHz (Range 1), or **greater** than 156 MHz (Range 2), turn the five tuning screws in (clockwise) until 1/8" protrudes past each of the tension nuts.

If the alignment frequency is **less** than, or **equal** to 148 MHz (Range 1), or 156 MHz (Range 2), back out (counterclockwise) the five tuning screws until 3/4" protrudes past each of the tension nuts.

Step 5. Using the torque driver and deep-well socket, tighten the five tension nuts on the adjustment screws to 6 in. – lb.

Step 6. Connect the test equipment as shown in Figure 12.

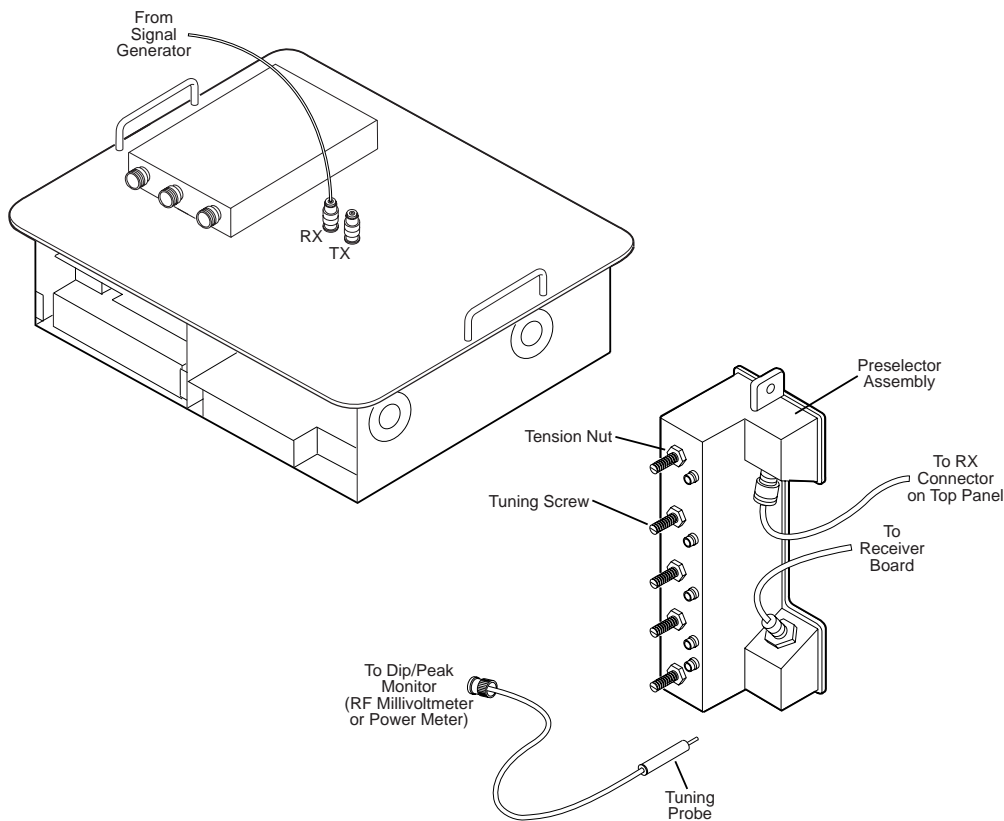

MAEPF-27038-O

**Figure 12 Test Equipment Setup for Preselector Field Tuning**

## VHF Tuning Procedure

- Step 1. Provide power to the PDR 3500 through either DC or AC (to provide the active 50  $\Omega$  termination).
- Step 2. Adjust the signal generator to the frequency calculated on page 36. Set the level to +5 dBm.

- Step 3. Insert the tuning probe into the cavity “H1” and adjust tuning screw 1 for a **PEAK**.
- Step 4. Leave the tuning probe in cavity “H1” and adjust tuning screw 2 for a **DIP**.
- Step 5. Insert the tuning probe into cavity “H2” and adjust tuning screw 3 for a **DIP**.
- Step 6. Insert the tuning probe into cavity “H3” and adjust tuning screw 4 for a **DIP**.
- Step 7. Insert the tuning probe into cavity “H4” and decrease the output from the signal generator to -5 dBm.
- Step 8. Adjust tuning screw 5 for a **DIP**. Then turn tuning screw 5 one-quarter turn counterclockwise.

**NOTE:** The DIP will not be as sharp for screw 5 as it was for screws 2 through 4.

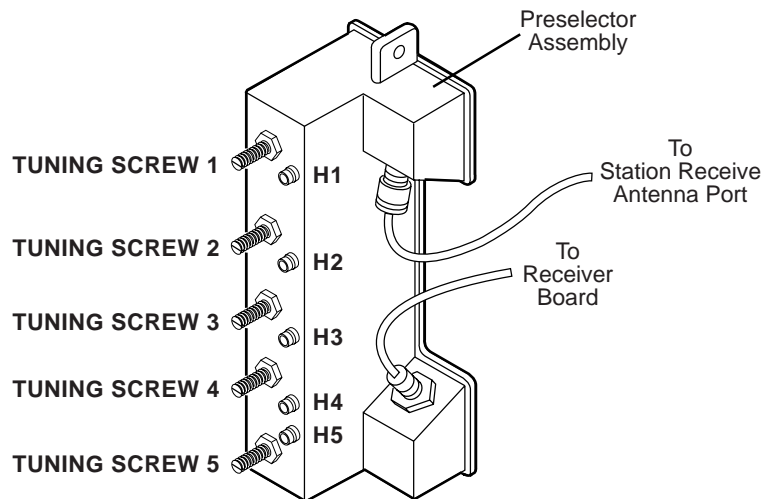

MAEPF-27039-O

*Figure 13 Location of Tuning Screws and Cavity Probe Holes*

## UHF Tuning Procedure

### Calculating Proper Alignment Frequency

Use one of the following two methods to calculate the alignment frequency to be generated by the signal generator.

For stations with a **single receive frequency**, calculate the frequency of the alignment signal as follows:

- Step 1. From the site documentation, or the RSS, determine the station receive frequency. **Add 200 kHz.**
- Step 2. If the Receiver Module is **Range 1**, determine the alignment frequency as follows:

If the frequency (from Step 1) is > 431 MHz, then the alignment frequency = 431 MHz.

If the frequency (from Step 1) is < 405 MHz, then the alignment frequency = 405 MHz.

Otherwise, use the actual frequency from Step 1.

Step 3. If Receiver Module is **Range 2**, determine the alignment frequency as follows:

If the frequency (from Step 1) is > 468 MHz, then the alignment frequency = 468 MHz.

If the frequency (from Step 1) is < 440 MHz, then the alignment frequency = 440 MHz.

Otherwise, use the actual frequency from Step 1.

Step 4. If the Receiver Module is **Range 3 or 4**, determine the alignment frequency as follows:

If the frequency (from Step 1) is > 518 MHz, then the alignment frequency = 518 MHz.

If the frequency (from Step 1) is < 472 MHz, then the alignment frequency = 472 MHz.

Otherwise, use the actual frequency from Step 1.

For stations with **multiple receive frequencies**, calculate the frequencies of the alignment signal as follows:

Step 1. From the site documentation, or the RSS, note the receive frequency for each channel supported by the station.

Step 2. Calculate a midpoint frequency as follows:

$$F_{\text{mid}} = (F_{\text{highest}} + F_{\text{lowest}}) \div 2$$

Step 3. Using  $F_{\text{mid}}$  in place of the station receive frequency, perform Step 1 through Step 4 above.

## Preparing Equipment

Step 1. Make sure the Receiver Module (with the Preselector Assembly) is installed in a functional PDR 3500.

- Step 2. Remove the chassis from its case by removing the eight Phillips screws from the edges of the station's top panel.
- Step 3. Remove the two Torx screws from the Receiver Module front panel and remove the four Phillips screws. Remove the panel.
- Step 4. Using the torque driver and deep-well socket, loosen the three tension nuts on the adjustment screws.
- Step 5. De-tune the preselector as follows:  
Turn tuning screws **3** and **4** clockwise until they bottom out. Be careful not to apply more than 3 in. – lb. of torque to prevent warping the preselector cover and housing.
- Step 6. Connect the test equipment as shown in Figure 14.

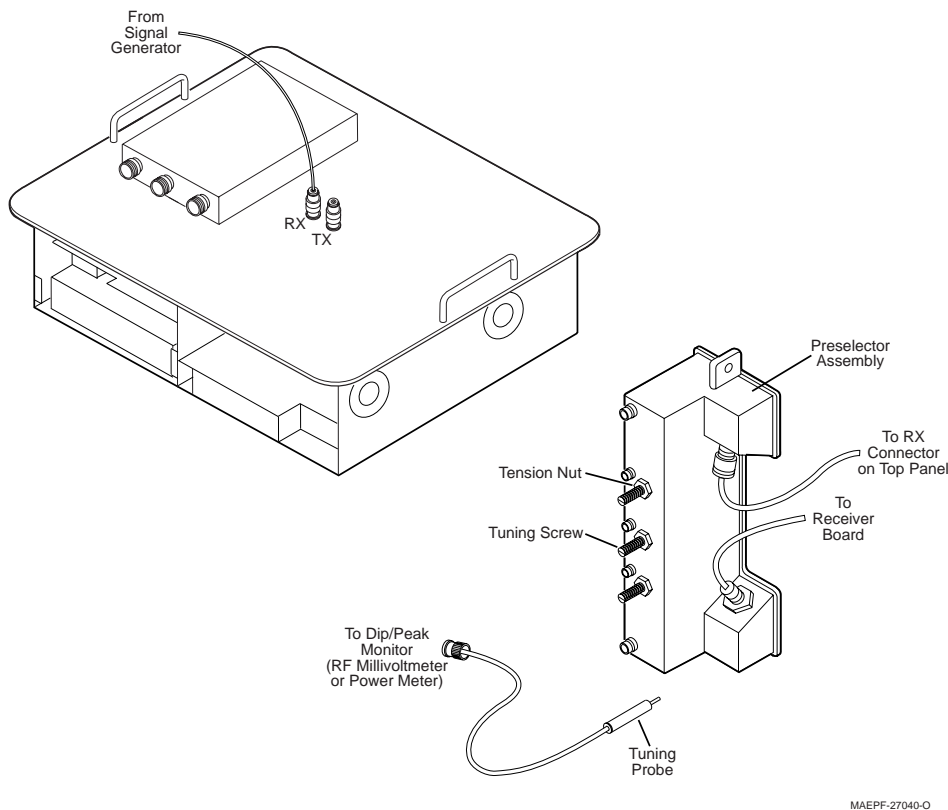
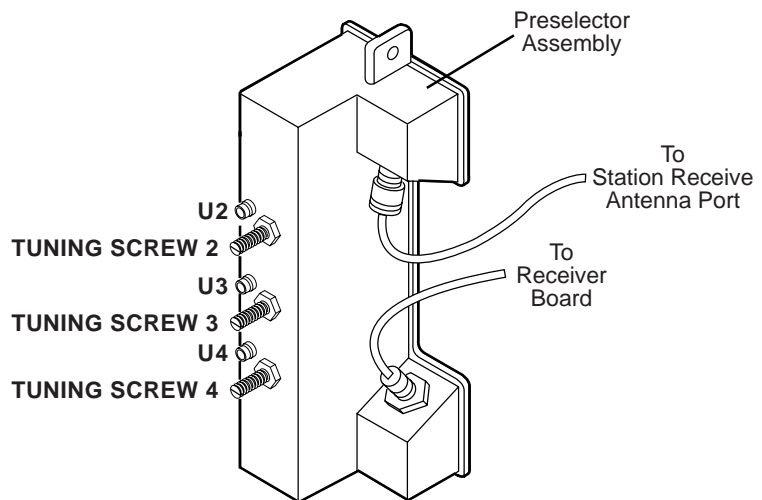

**Figure 14 Test Equipment Setup for Preselector Field Tuning**

## Tuning Procedure

- Step 1. Turn the station power supply ON (to provide the active 50  $\Omega$  termination).
- Step 2. Adjust the signal generator to the frequency calculated on page 39. Set the level to +5 dBm.

- Step 3. Insert the tuning probe into the cavity “U2” and adjust tuning screw 2 for a **PEAK**.
- Step 4. Tighten tension nut on tuning screw 2 to at least 12 in. – lb. and fine tune tuning screw 2 for a **PEAK**.
- Step 5. Keep the tuning probe in cavity “U2” and adjust tuning screw 3 for a **DIP**.
- Step 6. Tighten tension nut on tuning screw 3 to at least 12 in. – lb. and fine tune tuning screw 3 for a **DIP**.
- Step 7. Insert the tuning probe into cavity “U3” and decrease the output from the signal generator to -5 dBm.
- Step 8. Adjust tuning screw 4 for a **DIP**.
- Step 9. Tighten tension nut on tuning screw 4 to at least 12 in. – lb. and fine tune tuning screw 4 for a **DIP**.



MAEPF-27041-O

*Figure 15 Location of Tuning Screws and Cavity Probe Holes*

# Functional Theory of Operation

# 10

The following functional theory of operation provides an overview of the station circuitry. For a more thorough functional description of a particular module, refer to the appropriate section of the *Quantar User's Guide* (68P81095E05). Refer to the block diagram in Figure 16. for the following functional theory of operation.

---

## Transmitter Circuitry Operation

### Introduction

The Transmitter Circuitry consists of the following:

- **Exciter Module**
- **Power Amplifier (PA) Module**

These modules combine to produce the modulated, amplified RF signal. The RF signal is transmitted via the station transmit antenna.

### Exciter Module Operation

The Exciter Module is a microprocessor-controlled module, generating a modulated RF signal at the desired transmit frequency. It sends this signal to the Power Amplifier for amplification. The circuitry operates as follows:

1. The Synthesizer/Voltage-Control Oscillator (VCO) accepts frequency programming data from the Station Control Module (SCM) via the Serial Peripheral Interface (SPI) bus and generates an RF carrier signal at the specified frequency.

The modulation audio signal from the SCM modulates the carrier, resulting in a modulated RF signal at approximately +13dBm. The modulated signal is routed to the Power Amplifier.

2. The TX Power Control Circuitry accepts an output power detect voltage from the Power Amplifier and compares this signal to a reference voltage representing the desired output power.

Based on the comparison, a power control voltage is generated to control the output power from the PA. This feedback and control loop continually monitors the output power. It adjusts the control voltage to maintain the proper output power from the PA.



## Power Amplifier Module Operation

The PDR 3500 uses the mid-power Spectra RF power amplifier (RF PA) board, housed in a heavy-duty, shielded, aluminum heat sink. The gain of the RF PA board is controlled by the power control voltage from the Exciter Module.

The modulated RF signal is amplified by the RF PA and sent to the site transmit antenna.

The transmit path inside the RF PA contains a directional coupler (calibrated at setup), which feeds a DC voltage (proportional to the output power) to the TX Power Control Circuitry in the Exciter Module. This signal serves as the feedback signal in the power control loop.

---

## Receiver Circuitry

### Introduction

The Receiver Circuitry performs the following functions:

- Accepts receive RF signals from the site receive antenna
- Filters and dual conversion
- Outputs a digitized receive signal to the Station Control Module.

### Receiver Module Operation

The receive signal is generated from the site receive antenna to a multi-pole, preselector filter which provides highly selective bandpass filtering.

The filtered signal is then amplified and fed to the RF input of the 1st mixer.

The 1st mixer combines the filtered signal with an injection signal generated by the Synthesizer/VCO. This results in a 21.45 MHz (VHF), or 73.35 MHz (UHF) 1st IF (intermediate frequency) signal. (The injection signal is determined by frequency programming data from the Station Control Module via the SPI bus.)

The 21.45 or 73.35 MHz 1st IF is filtered and routed to a custom receiver IC. This component contains the following circuitry:

- 2nd injection and mixing
- Amplification
- A/D (analog to digital) conversion

This results in a digitized receive signal. This signal is routed to the Station Control Module as differential data.

---

## Station Control Module

### Introduction

The Station Control Module (SCM) is the microprocessor-based controller for the station. Major components include the following:

- MC68360 microprocessor,
- 56002 Digital Signal Processor (DSP)
- Two Application Specific Integrated Circuit (ASIC) devices (host and DSP).

### Station Control Module Operation

The Host Microprocessor ( $\mu$ P) serves as the controller for the SCM, operating from the station software stored in FLASH memory. This software determines the system capabilities of the station (analog, *ASTRO*, *SECURENET*, etc.).

The Host  $\mu$ P communicates with the station modules and the SCM circuitry via address and data buses, a High-Level Data Link Control (HDLC) bus, and a Serial Peripheral Interface (SPI) bus. External communications is accomplished using a serial port on the top panel.

The DSP and DSP ASIC perform the necessary digital signal processing for the station audio and data signals. The DSP circuitry interfaces with the Receiver Module (receive audio), the Exciter Module (modulation signal), and the Wireline Interface Board (wireline audio).

The 2.1 MHz Reference Oscillator generates the reference signal used by the Receiver and Exciter Modules.

---

## Wireline Interface Board

### Introduction

The Wireline Interface Board (WIB) serves as the interface between the customer telephone lines and the station. In general, the WIB processes and routes all wireline audio signals between the station and the landline equipment (such as consoles, modems, etc.). Landline-to-station and station-to-landline audio signals are connected to the WIB via RJ-45 connectors on the top panel of the station.

### Wireline Interface Board Operation

The WIB contains the following:

- A microprocessor

- Two FLASH memory ICs (which contain the WIB operating software downloaded by the SCM)
- An ASIC device to process and route the various audio signals

Analog, *SECURENET*, and *ASTRO* signals are processed as follows:

- Analog signals are converted to digital signals and routed to the Station Control Module via the Time Division Multiplex (TDM) bus.
- *ASTRO* and *ASTRO CAI* data signals are processed by an *ASTRO* modem card (the daughter board is plugged into the WIB) and sent to/from the SCM via the HDLC bus. (The station operates in transparent mode only, and does not perform encryption or decryption of the *ASTRO* or *ASTRO CAI* signal.)
- *SECURENET* encoded signals are processed by the ASIC, sent to/from the microprocessor via the data bus, and sent to/from the Station Control Module microprocessor via the HDLC bus. (The station operates in transparent mode only, and does not perform encryption or decryption of the *SECURENET* signal.)

**NOTE:** The WIB is offered in the 4-wire configuration only.

---

## Power Supply Module Operation

The Power Supply Module is a switching-type power supply which accepts an AC input (85-265 VAC, 49-61 Hz) and generates the 13.8 VDC for the station modules and the power regulation circuitry on the motherboard.

The Power Supply Module is capable of 12 A continuous load and 18 A maximum load.