



**MOTOROLA**  
*intelligence everywhere™*

**75**

**ASTRO®**  
**XTL™ 5000**  
Digital Mobile Radio



W4, W5, W7, W9 Control Heads  
User's Guide



# ASTRO® XTL™ 5000 Digital Mobile Radio with W4 Control Head

## Quick Reference Card

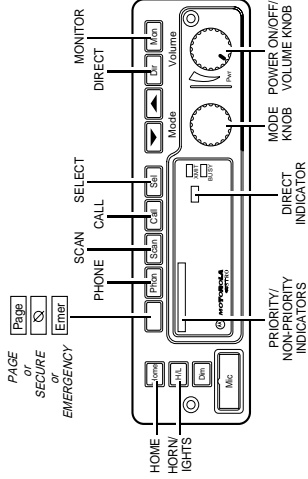

### BASIC OPERATION

#### Turning the Radio On and Off

Rotate the **Vol** (Volume) knob clockwise.

#### Setting the Volume and Squelch

- 1 Turn the **Vol** knob clockwise to increase volume or counterclockwise to decrease volume as desired.
- 2 On conventional modes with Private-Line or Digital Private-Line, press **Mon** or remove the microphone from the hang-up clip to defeat the coded squelch.
- 3 Press **Mon** again, or replace the microphone on the hang-up clip to return to coded-squelch operation.
- 4 To adjust squelch level, hold **Mon** until a tone sounds.
- 5 Turn **Mode** knob to select squelch level.
- 6 Press **Home**.

#### Changing Modes

Turn the **Mode** knob to select the desired mode

**OR**

Press **Home** to access the preprogrammed Home mode.

#### Transmitting

- 1 Press and hold the microphone **PTT** button.
- 2 When the transmit light comes on solid and no alert tones sound (or a talk-permit tone or ID sidetone sounds), speak into the microphone in a normal voice.
- 3 State your FCC call sign at the beginning of each transmission.

#### Transmitting (Conventional Modes)

- 1 Press **Dir** (Direct). The **Dir** indicator lights.
- 2 Press **Dir** again to return to repeater operation.

### Activating Scan

- 1 Press **Scan** to start a scan. If no activity exists, the display shows your selected mode. When a scanned channel or talkgroup becomes active, the display shows the active mode name. The **PRI** and **NPRI** indicators show priority.
- 2 Press **Scan** again to stop scanning.

### Programming a Scan List

- 1 Hold **Scan** until a tone sounds and the scan indicator blinks.
- 2 Turn the **Mode** knob to select the mode you want to program.
- 3 Press the **Sel** button as indicated in the table below to add or remove the displayed mode from the scan list.
- 4 Repeat the previous steps to continue editing the list.
- 5 Press **Home** or **Scan** to exit.

Press Sel	Mode	Indicator
One time	Non-Priority	NPRI lit
Two times	Second Priority	PRI lit
Three times	First Priority	PRI blinks
Four times	Delete from List	No indicator

### Selecting Scan Mode Priority

- 1 Press the **Sel** button as indicated in the table above to designate up to two modes as priorities.
- 2 Press **Home** or **Scan** to end scan list selection.

## Sending an Emergency Alarm or Call

Press the emergency actuator (**Emer** button, footswitch, hidden pushbutton) to begin an emergency transmission.

For conventional modes, a silent or non-silent emergency alarm data transmission is sent.

For trunked modes, emergency call (priority access to a voice channel), silent or non-silent emergency alarm, or emergency alarm and call is entered.

Depending on your radio's programming, one of the emergency sequences described in the table below occur.

Alarm Type	Indications/Actions
Non-Silent	A tone sounds and the display alternates between <b>EMERGENCY</b> and the zone/channel. When acknowledged, four more tones sound and the display shows <b>RICK RCVUD</b> , then the radio returns to normal operation.
Silent	The audio is muted and no display changes take place during the alarm. Press the <b>PTT</b> button, or press and hold the emergency button to stop the emergency condition and unmute the radio.
Call (Trunked Modes only)	A tone sounds and the display alternates between <b>EMERGENCY</b> and the zone/channel. Press the <b>PTT</b> button and talk. After completing the call, press and hold the emergency actuator until a tone sounds to return to normal operation.

Alarm Type	Indications/Actions
Alarm and Call	After <b>RICK RCVUD</b> (see Non-Silent Alarm above) is displayed, the radio has priority voice-channel access. Press the <b>PTT</b> button and talk. After completing the call, press and hold the emergency actuator until a tone sounds to return to normal operation.

**2** If the receiving unit answers, press the **PTT** button to identify yourself and proceed with your call.

**OR**

If the called unit does not respond, press **Sel** or the **PTT** button again to leave a Call Alert page message and your ID.

A single tone followed by four tones sounds if the called unit acknowledges the page.

## Initiating a Call Alert Page

- 1 Press the **Page** button.
- 2 Follow the instructions for initiating a Private Conversation to select a unit ID.

**3** Press **Sel** or the **PTT** button to send a Call Alert page to the displayed ID.

**OR**

To send a Call Alert page following an Enhanced Private Conversation attempt, follow the instructions for sending a direct-entry Enhanced Private Conversation call.

## Answering a Call Alert Page

Four tones sound and **PAGE RCV** flashes on the display. The tone and display repeat every five seconds.

- 1 Press the **PTT** button,

**OR**

Initiate an Enhanced Private Conversation call to the caller.

## Sending a Status Transmission

- 1 Press **Sts**. The display shows the last acknowledged status or first status name.
- 2 Rotate **Mode** to select other statuses.

**3** Press **Sel** to send the transmission. The display flashes the selected status/message name until the dispatcher acknowledges, at which time alert tones sound and the display shows **RICK RCVUD**. The radio then returns to normal operation.

## Sending a Direct-Entry Keyboard Status Transmission

Press the appropriate **Sts #** button you wish to send. The associated indicator blinks until an acknowledgment is received, then it lights steadily.

## Sending a Direct-Entry Enhanced Private Conversation Call

- 1 Press **Sel** or the **PTT** button. A single tone sounds and the display changes to **PLS WFTT**, followed by telephone-type ringing if the receiving unit is in service.

## Selecting a Zone/Mode (Optional)

- 1 Press the **Zone Up** ▲ button or **Zone Down** ▼ button to scroll to the desired zone.
- 2 Turn the **Mode** knob to select the mode.

## Selecting a Home Zone/Home Mode

Press the **Home** button.

## Selecting Secure Mode

Press and release the **Q** button. The **Q** indicator lights up.

## Selecting an Encryption Key

- 1 Press and hold the **Q** button until a tone sounds.
- 2 Turn the **Mode** knob to scroll to **KEY SEL**.
- 3 Press **Sel** to enter the Key Selection Menu.
- 4 Turn the **Mode** knob to select desired key.
- 5 Press **Sel** to select key.
- 6 Press **Home** or the **PTT** button to quit.

## Selecting a Key Index

- 1 Press and hold the **Q** button until a tone sounds.
- 2 Turn the **Mode** knob to scroll to **INDEX SEL**.
- 3 Press **Sel** to enter the Index Selection Menu.
- 4 Turn the **Mode** knob to select desired index.
- 5 Press **Sel** to select index.
- 6 Press **Home** or the **PTT** button to quit.

## Erasing an Encryption Key

- 1 Press and hold the **Q** button until a tone sounds.
- 2 Turn the **Mode** knob to scroll to **ERASE KY**.
- 3 Press **Sel** to enter the Key Erase Menu.
- 4 Turn the **Mode** knob to select desired index.
- 5 Press **Sel** to select index.
- 6 Press **Home** or the **PTT** button to quit.

## DISPLAY AND LIGHT INDICATORS

<i>Display/Light</i>	<i>Meaning</i>
<b>BUSY</b> light on	Displayed conventional mode has activity on it, or selected trunked system is currently busy. Wait for callback.
<b>XMIT</b> light on	Indicates you are transmitting.
<b>Dir</b> indicator lit	Radio is in direct (mobile-to-mobile) operation.
<b>PRI, NPRI</b> indicators lit	Display shows a mode in the scan list with the indicated priority level.
<b>P</b> displayed	Telephone dialing pause. Press <b>Sel</b> to continue the dialing.
<b>NO ACK</b> displayed	Unit being called with the Enhanced Private Conversation or Call Alert Page feature is not in service, or emergency alarm or status/message transmission is not acknowledged by dispatcher.
<b>NO ANSWR</b> displayed	Unit being called with Enhanced Private Conversation or Call Alert Page does not respond, but is operational.
<b>EMERGENCY</b> displayed	Radio is in emergency alarm or call state.
<b>NO EMERG</b> displayed	A mode incapable of emergency transmission has been selected.
<b>OUT RING</b> displayed	Radio is out of range of the trunking system.

## ALERT TONES

Type of Tone	Name	Explanation
1 Low-Pitched Tone	Invalid Key Alert	Feature button pressed is not valid in selected mode, or a Call/Alert or emergency alarm was not acknowledged.
1 High-Pitched Tone	Central Acknowledge or Valid Key	Central controller has received request for Call/Alert or emergency alarm transmission. You pressed a valid key.
4 High-Pitched Tones	Dispatcher or Mobile Unit Acknowledge	Dispatcher is acknowledging your emergency transmission. Mobile unit has received your Call Alert.
5 High-Pitched Tones		The above two acknowledge tones, heard in tandem.
2 High-Pitched Tones	Private Conversation	You have an incoming call. Press <b>Call</b> , then the <b>PTT</b> button, then talk.
4 High-Pitched Tones every 6 seconds	Call Alert Page	Call Alert page has been received.
Phone-Type Busy Tone (when pressing the <b>PTT</b> button)	System Busy	All system radio channels in use. Release the <b>PTT</b> button, and wait for callback.

## ALERT TONES (Continued)

Type of Tone	Name	Explanation
3 Short High-Tones (after requesting a busy channel) upon pressing the <b>PTT</b> button)	Automatic Call Back or Talk Permit	Channel is available for previously requested transmission. System is accepting your transmission.
Low-Pitched Tone (upon pressing the <b>PTT</b> button during Transmission (Operation Error)	Talk Prohibit/ Out-of-Range or Time-Out Timer or Illegal Mode	Out of trunked radio system range or system is out of service. Present transmission will soon be disabled. You have entered a mode where normal system traffic will be missed, or you attempted something that is not allowed. (See examples below.)
High-Pitched Tone every 10 seconds in un-muted receive condition	Failsoft	System central controller failure. The radio reverts from trunked operation to a operation similar to a conventional repeater. Others may share the channel.

**Examples:** Not exiting phone mode after a call (radio cannot receive fleet or subfleet calls), transmitting in receive-only conventional mode, trying to select a dynamic mode when no dynamic ID assignment has been made.



## Sending an Emergency Alarm or Call

Press the emergency actuator (**Emer** button, footswitch, hidden pushbutton) to begin an emergency transmission.

For conventional modes, a silent or non-silent emergency alarm data transmission is sent.

For trunked modes, emergency call (priority access to a voice channel), silent or non-silent emergency alarm, or emergency alarm and call is entered.

Depending on your radio's programming, one of the emergency sequences described in the table below occur.

Alarm Type	Indications/Actions
Non-Silent	A tone sounds and the display flashes <b>EMERGENCY</b> . When acknowledged, four more tones sound and the display shows <b>RICK RCVUD</b> , then the radio returns to normal operation.
Silent	The audio is muted and no display changes take place during the alarm.  Press the <b>PTT</b> button, or press and hold the emergency button to stop the emergency condition and unmute the radio.
Call (Trunked Modes only)	A tone sounds and the display flashes <b>EMERGENCY</b> .  Press the <b>PTT</b> button and talk.  After completing the call, press and hold the emergency actuator until a tone sounds to return to normal operation.

Alarm Type	Indications/Actions
Alarm and Call	After the display shows <b>RICK RCVUD</b> (see Non-Silent Alarm above), the radio has priority voice-channel access.  Press the <b>PTT</b> button and talk.  After completing the call, press and hold the emergency actuator until a tone sounds to return to normal operation.

## Sending a Status Transmission

- 1 Press **Sts**. The display shows the last acknowledged status or the first status name.
- 2 Press the **Mode** rocker switch to select other statuses.
- 3 Press **Sel** to send the transmission. The display flashes the selected status name until the dispatcher acknowledges, at which time alert tones sound and the display shows **RICK RCVUD**. The radio then returns to normal operation.

## Sending a Direct-Entry Keyboard Status Transmission

Press the appropriate **Sts #** button that you wish to send. The associated indicator blinks until an acknowledgment is received, then it lights steadily.

## Sending a Direct-Entry Enhanced Private Conversation Call

- 1 Press **Sel** or the **PTT** button. A single tone sounds and the display changes to **PLS WPTT**, followed by telephone-type ringing if the receiving unit is in service.

- 2 If the receiving unit answers, press the **PTT** button to identify yourself and proceed with your call.

**OR**

If the called unit does not respond, press **Sel** or the **PTT** button again to leave a Call Alert page message and your ID.

A single tone followed by four tones sounds if the called unit acknowledges the page.

## Initiating a Call Alert Page

- 1 Press the **Page** button.
  - 2 Follow the instructions for initiating a Private Conversation to select a unit ID.
  - 3 Press **Sel** or the **PTT** button to send a Call Alert page to the displayed ID.
- OR**
- To send a Call Alert page following an Enhanced Private Conversation attempt, follow the instructions for sending a direct-entry Enhanced Private Conversation call.

## Answering a Call Alert Page

Four tones sound and **PAGE RCV** flashes on the display. The tone and display repeat every five seconds.

- 1 Press the **PTT** button,

**OR**

Initiate an Enhanced Private Conversation call to the caller.



## Selecting a Zone/Mode (Optional)

- 1 Press the **Zone Up** ▲ button or **Zone Down** ▼ button to scroll to the desired zone.
- 2 Press the **Mode** rocker switch to select the mode.

## Selecting a Home Zone/Home Mode

Press the **HOME** button.

## Selecting Secure Mode

Press and release the **Q** button. The **Q** indicator lights up.

## Selecting an Encryption Key

- 1 Press and hold the **Q** button until a tone sounds.
- 2 Press the **Mode** rocker switch to scroll to **KEY SEL**.
- 3 Press **Sel** to enter the Key Selection Menu.
- 4 Press the **Mode** rocker switch to select the desired key.
- 5 Press **Sel** to select the key.
- 6 Press **HOME** or the **PTT** button to quit.

## Selecting a Key Index

- 1 Press and hold the **Q** button until a tone sounds.
- 2 Press the **Mode** rocker switch to scroll to **INDEX SEL**.
- 3 Press **Sel** to enter the Index Selection Menu.
- 4 Press the **Mode** rocker switch to select the desired index.
- 5 Press **Sel** to select the index.
- 6 Press **HOME** or the **PTT** button to quit.

## Erasing an Encryption Key

- 1 Press and hold the **Q** button until a tone sounds.
- 2 Press the **Mode** rocker switch to scroll to **ERASE KEY**.
- 3 Press **Sel** to enter the Key Erase Menu.
- 4 Press the **Mode** rocker switch to select the desired index.
- 5 Press **Sel** to select the index.
- 6 Press **HOME** or the **PTT** button to quit.

## DISPLAY AND LIGHT INDICATORS

<b>Display/Light</b>	<b>Meaning</b>
<b>BUSY</b> light on	The conventional mode in the display has activity on it, or selected trunked system is currently busy. Wait for callback.
<b>XMIT</b> light on	Indicates you are transmitting.
<b>Dir</b> indicator lit	Radio is in direct (mobile-to-mobile) operation.
<b>PRI, NPRI</b> indicators lit	The display shows the mode in the scan list with the indicated priority level.
<b>P</b> displayed	Telephone dialing pause. Press <b>Sel</b> to continue the dialing.
<b>NO RICK</b> displayed	Unit being called with the Enhanced Private Conversation or Call Alert Page feature is not in service, or emergency alarm or status/message transmission is not acknowledged by dispatcher.
<b>NO RANSUR</b> displayed	Unit being called with Enhanced Private Conversation or Call Alert Page does not respond, but is operational.
<b>EMERGENCY</b> displayed	Radio is in emergency alarm or call state.
<b>NO EMERG</b> displayed	A mode incapable of emergency transmission has been selected.
<b>OUT RING</b> displayed	Radio is out of range of the trunking system.

## ALERT TONES

Type of Tone	Name	Explanation
1 Low-Pitched Tone	Invalid Key Alert	Feature button pressed is not valid in selected mode, or a Call/Alert or emergency alarm was not acknowledged.
1 High-Pitched Tone	Central Acknowledge or Valid Key	Central controller has received request for Call/Alert or emergency alarm transmission. You pressed a valid key.
4 High-Pitched Tones	Dispatcher or Mobile Unit Acknowledge	Dispatcher is acknowledging your emergency transmission. Mobile unit has received your Call Alert.
5 High-Pitched Tones		The above two acknowledge tones, heard in tandem.
2 High-Pitched Tones	Private Conversation	You have an incoming call. Press <b>Call</b> , then the <b>PTT</b> button, then talk.
4 High-Pitched Tones every 6 seconds	Call Alert Page	Call Alert page has been received.
Phone-Type Busy Tone (when pressing the <b>PTT</b> button)	System Busy	All system radio channels in use. Release the <b>PTT</b> button, and wait for callback.

## ALERT TONES (Continued)

Type of Tone	Name	Explanation
3 Short High-Tones (after requesting a busy channel) upon pressing the <b>PTT</b> button)	Automatic Call Back or Talk Permit	Channel is available for previously requested transmission. System is accepting your transmission.
Low-Pitched Tone (upon pressing the <b>PTT</b> button during Transmission (Operation Error)	Talk Prohibit/ Out-of-Range or Time-Out Timer or Illegal Mode	Out of trunked radio system range or system is out of service. Present transmission will soon be disabled. You have entered a mode where normal system traffic will be missed, or you attempted something that is not allowed. (See examples below.)
High-Pitched Tone every 10 seconds in unmutated receive condition	Failsoft	System central controller failure. The radio reverts from trunked operation to a conventional repeater. Others may share the channel.

**Examples:** Not exiting phone mode after a call (radio cannot receive fleet or subfleet calls), transmitting in receive-only conventional mode, trying to select a dynamic mode when no dynamic ID assignment has been made.

# W4 and W5 Control Heads Foldout Page

## W4 Control Head

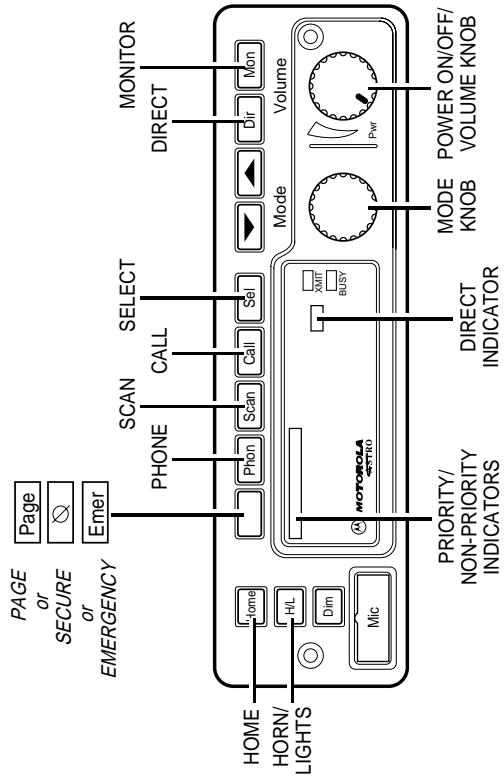

## W5 Control Head

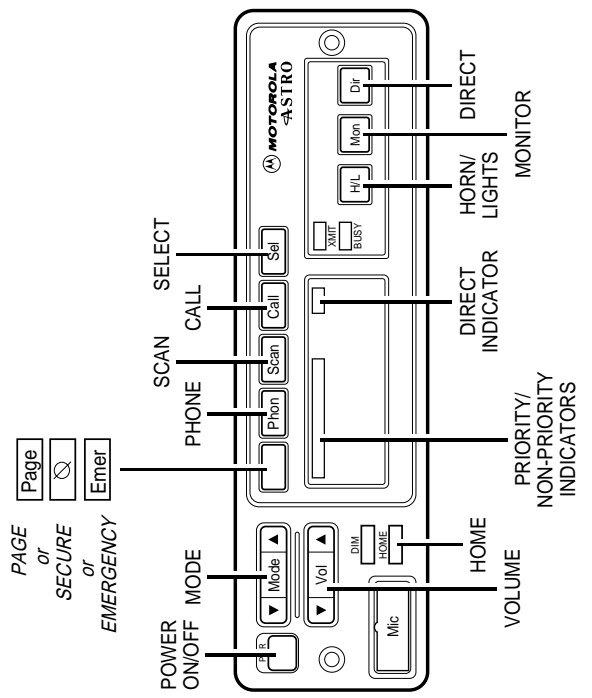



**ASTRO® XTL™ 5000  
Digital Mobile Radio  
with  
W4, W5, W7, and W9  
Control Heads  
User's Guide**

**68P81096C68-O**

***Document Creation Date: 3/12/03  
Document Modification Date: 0/00/03***

---

## Product Safety and RF Exposure Compliance



Caution

Before using this product, read the operating instructions for safe usage contained in the Product Safety and RF Exposure booklet enclosed with your radio.

### ATTENTION!

This radio is restricted to occupational use only to satisfy FCC RF energy exposure requirements. Before using this product, read the RF energy awareness information and operating instructions in the Product Safety and RF Exposure booklet enclosed with your radio (Motorola Publication part number 68P81095C99) to ensure compliance with RF energy exposure limits.

### Computer Software Copyrights

The Motorola products described in this manual may include copyrighted Motorola computer programs stored in semiconductor memories or other media. Laws in the United States and other countries preserve for Motorola certain exclusive rights for copyrighted computer programs, including, but not limited to, the exclusive right to copy or reproduce in any form the copyrighted computer program. Accordingly, any copyrighted Motorola computer programs contained in the Motorola products described in this manual may not be copied, reproduced, modified, reverse-engineered, or distributed in any manner without the express written permission of Motorola. Furthermore, the purchase of Motorola products shall not be deemed to grant either directly or by implication, estoppel, or otherwise, any license under the copyrights, patents or patent applications of Motorola, except for the normal non-exclusive license to use that arises by operation of law in the sale of a product.

### Documentation Copyrights

No duplication or distribution of this document or any portion thereof shall take place without the express written permission of Motorola. No part of this manual may be reproduced, distributed, or transmitted in any form or by any means, electronic or mechanical, for any purpose without the express written permission of Motorola.

### Disclaimer

The information in this document is carefully examined, and is believed to be entirely reliable. However, no responsibility is assumed for inaccuracies. Furthermore, Motorola reserves the right to make changes to any products herein to improve readability, function, or design. Motorola does not assume any liability arising out of the applications or use of any product or circuit described herein; nor does it cover any license under its patent rights, nor the rights of others.

MOTOROLA, the Stylized M Logo, ASTRO, SmartZone, and FLASHport are registered in the U.S. Patent & Trademark Office. All other product or service names are the property of their respective owners. P25 radios contain technology patented by Digital Voice Systems, Inc.

© Motorola, Inc. 2003. All Rights Reserved. Printed in the U.S.A. 4/03.

---

## Notations Used in This Manual

Throughout the text in this publication, you will notice the use of WARNINGS, CAUTIONS, and Notes. These notations are used to emphasize that safety hazards exist, and care that must be taken or observed.



**WARNING:** An operational procedure, practice, or other condition, which might result in injury or death if not carefully observed.



**CAUTION:** An operational procedure, practice, or other condition, which might result in damage to the equipment if not carefully observed.

**Note:** Note: An operational procedure, practice, or other condition, which is essential to emphasize.

The following special notations identify certain items:

<i>Example</i>	<i>Description</i>
Light button or 	Buttons and keys are shown in bold print or as a key symbol.
PHONE	Menu items (softkeys) are similar to the way they appear on the radio's display.

---

## Notes



# Contents

---

<b>W4 and W5 Control Heads Foldout Page</b> . . . . .	<b>i</b>
Computer Software Copyrights	iv
Documentation Copyrights	iv
Disclaimer	iv
Notations Used in This Manual	v
<b>Introduction</b> . . . . .	<b>1</b>
Using Your Radio: The Basics	1
Getting Started	2
Identifying Your Radio	4
W4 Control Head	4
W5 Control Head	4
W7 Control Head	4
W9 Control Head	4
Operating Your Control Head	5
Turning On the Radio	5
Trunked or Conventional	7
Field Programming	7
Display Status	8
Feature Control	8
Alert Tones	8
<b>Basic Operating Procedures</b> . . . . .	<b>11</b>
Basic Functions	11
Selecting the Zone or Mode	12
Selecting or Changing the Zone	12
Selecting or Changing a Mode in the Current Zone	13
Selecting or Changing to a Mode Not in the Current Zone	13
Selecting the Home Mode	14
Transmitting (Conventional Modes Only)	15
Transmitting (Trunked Modes Only)	15
Selecting the Transmit Power Level	16
Monitoring Conventional Mode Activity	17
Adjusting the Squelch Level	18
<b>General Radio Features</b> . . . . .	<b>19</b>
Often-used Features	19
Emergency Call and Alarm	20
Emergency Call	20
Initiating an Emergency Alarm	21

---

Initiating an Emergency Call .....	22
Initiating an Emergency Call and Alarm .....	23
Initiating a Silent Emergency Alarm .....	24
Special Considerations for Emergencies .....	25
Scan Operation .....	26
Turning On Scan .....	27
Turning Scan On While Disregarding the Squelch Code (Conventional Modes Only) .....	28
Viewing a Scan List .....	29
Transmitting While Scan Is On .....	30
Temporarily Deleting a Nuisance Mode With Scan On (W7 and W9 Control Heads Only) .....	31
Restoring a Nuisance Mode (W7 and W9 Control Heads Only) .....	32
Changing Mode Priorities While Scan Is On (W7 and W9 Control Heads Only) .....	33
Restoring Mode Priorities in a Scan List (W7 and W9 Control Heads Only) .....	33
Programming a Scan List .....	34
Hang Up Box (HUB) .....	36
Optional External Alarms (Horn and Lights) .....	36
Activating the External Alarm(s) .....	36
Changing the Selected Alarms .....	38
Receiving a Call While Alarms Are Turned On .....	39
Time-Out Timer .....	40
Push-To-Talk Identification (PTT-ID) .....	40
Telephone Interconnect List (Conventional and Trunking) .....	41
Answering a Phone Call .....	42
Initiating a Telephone Call From the List .....	42
Unlimited Telephone Interconnect (W7 and W9 Control Heads Only) .....	44
Calling a Phone Number Not in the List .....	44
Storing a Number in the List .....	46
Edit a Name in the List (W7 and W9 Control Heads Only) .....	47
Call Alert Page (Conventional and Trunking— Digital Modes Only)	50
Sending a Call Alert Page .....	51
Answering a Call Alert Page .....	53
Storing a Unit ID Number In the List (W7 and W9 Control Heads Only) .....	54

---

Editing a Name in the List (W7 and W9 Control Heads Only) .....	55
<b>Conventional Radio Features . . . . .</b>	<b>57</b>
Features Used in Conventional Operation .....	57
Status Calls (Digital Modes Only) .....	58
Sending a Status Call (W7 and W9 Control Heads Only) .....	58
Sending a Direct-Entry Keyboard (DEK) Status (Digital Modes Only) .....	60
Smart PTT .....	61
Conventional Talkgroup Calls .....	62
Digital Modes Only .....	62
Selecting a Conventional Talkgroup .....	62
Conventional Talkaround .....	64
Talk Direct (Mobile-To-Mobile) .....	64
Selective Call (Digital Modes Only) .....	65
Answering a Selective Call .....	66
Initiating a Selective Call .....	67
Viewing Your Unit ID Number .....	69
Storing a Unit ID Number in the List (W7 and W9 Control Heads Only) .....	70
Editing a Name in the List (W7 and W9 Control Heads Only) .....	71
<b>Trunking Operation . . . . .</b>	<b>73</b>
Features Used on Trunking Systems .....	73
Enhanced Private Conversation (Digital Modes Only) .....	74
Answering an Enhanced Private Conversation Call .....	75
Initiating an Enhanced Private Conversation Call .....	76
Storing a Unit ID Number In the Private Conversation List (W7 and W9 Control Heads Only) .....	78
Editing a Name in the Private Conversation List (W7 and W9 Control Heads Only) .....	79
Failsoft .....	81
Dynamic Regrouping (Digital Modes Only) .....	82
Receiving a Dynamic Regrouping ID Assignment (W7 and W9 Control Heads Only) .....	82
Selecting Enable and Disable (Digital Modes Only) .....	83

---

Requesting a Dynamic Regrouping (W7 and W9 Control Heads Only) (Digital Modes Only) .....	83
SmartZone® (W7 and W9 Control Heads Only) .....	85
Site-Button Operation .....	86
Locking Onto a Site .....	87
Site Trunking .....	88
Out-of-Range Indication .....	89
Trunked Announcement .....	90
Initiate an Announcement .....	91
<b>Secure Operation .....</b>	<b>93</b>
Features Available on Secure XTL 5000 .....	93
Receiving a Private Message .....	94
Transmitting a Private Message .....	94
System Considerations .....	95
Loss Indication .....	96
Selecting an Encryption Key (Conventional Only) .....	97
Selecting an Encryption Index (Conventional Only) .....	99
<b>Troubleshooting .....</b>	<b>100</b>
<b>Glossary .....</b>	<b>101</b>
Patent Disclosure .....	105
Commercial Warranty (Standard) .....	105
<b>Index .....</b>	<b>107</b>
<b>W7 and W9 Control Heads Foldout Page .....</b>	<b>113</b>

# Introduction

---

## Using Your Radio: The Basics

This chapter gives you the basic knowledge you need in order to use your radio. The following topics are covered:

- Getting Started (page 2)
- Identifying Your Radio (page 4)
- Operating Your Control Head (page 5)
- Turning On the Radio (page 5)
- Setting the Volume (page 6)
- Adjusting the Display Brightness (page 6)
- Display Status (page 8)
- Feature Control (page 8)
- Alert Tones (page 8)

## Getting Started

The ASTRO® XTL™ 5000 Digital Mobile Radio is among the most sophisticated two-way radios available. It can operate in the following frequency ranges:

<i>VHF</i>	<i>UHF</i>	<i>700/800 MHz</i>
136-174 MHz	380-470 MHz	764-776 MHz
	450-520 MHz	794-806 MHz
		806-825 MHz
		851-870 MHz

These channels provide maximum communications capability under varying operating conditions.

One of the newest in a long line of quality Motorola products, the ASTRO XTL 5000 Digital Mobile Radio provides improved voice quality across more of your coverage area. The digital process called *embedded signaling* intermixes system signaling information with digital voice, resulting in improved system reliability and the capability of supporting a multitude of advanced features. Such features add up to better, more cost-effective two-way radio communications.

ASTRO digital technology is also helping to provide the solution to improved spectral efficiency requiring only half as much bandwidth per channel (12.5kHz) compared to analog technology (25/30kHz). The net benefit to you is fewer users per channel or more users per system.

The ASTRO XTL 5000 Digital Mobile radio can include an optional RS-232 data port to interface with external devices, such as certain fax machines and laptop computers. ASTRO XTL 5000 Digital Mobile voice radios and data terminals can access the same channel without interfering with each other.

**Note:** In this manual—

*Analog mode* refers to a mode that uses traditional, non-ASTRO-digital signaling.

*ASTRO mode* refers to a mode that uses ASTRO digital signaling.

Your ASTRO XTL 5000 Digital Mobile Radio utilizes Motorola's revolutionary **FLASHport™** technology. This allows your radio's capabilities to be flexible, because **FLASHport** makes it possible to add software that drives these capabilities both at the time of purchase and later on. Similar to how a computer can be loaded with different software, your radio's features and capabilities can be upgraded with software.

**FLASHport** allows you to add software to your radio as your needs change and as technology advances, making your radio investment go further.

**FLASHport** is the future of radio communications, and it's yet another example of Motorola's commitment to your satisfaction.

## Identifying Your Radio

The ASTRO XTL 5000 Digital Mobile Radio's capabilities, and the operation of its features, differ depending on which control head is ordered. Keep the foldout pages open for reference as you read this manual. Your radio has one of the following control heads:

### **W4 Control Head**

The W4 has rotary **Mode** and **Volume** knobs and a limited set of control buttons, eight-digit display, and no 12-button keypad (page i).

### **W5 Control Head**

The W5 features a limited set of control buttons, eight-digit display, and no 12-button keypad (page i).

### **W7 Control Head**

The W7 has the same keys and display as the W5 control head, plus a 12-button keypad (page 113).

### **W9 Control Head**

The W9 has the identical keys and keypad as the W7 control head, but features an 11-digit display (page 113).



## Operating Your Control Head

Your advanced control head is designed for ease of use and flexibility of feature control. Before operating the radio, familiarize yourself with the various controls, indicators, and alert tones. Refer to the foldout diagrams in the front and back of this manual for your particular control head.

## Turning On the Radio

Basic operation is the same for all radio control heads. Control heads with additional features are noted.

Do one of the following:

- **W4 Control Heads:** Rotate the **Volume** knob clockwise.
- **W5 and W7 Control Heads:** Press the power button in the upper left corner of the control unit.
- **W9 Control Heads:** Slide the power switch on the bottom of the control unit to the left.

The display and graphics illuminate, indicating that the radio is on.

When the ASTRO XTL 5000 Digital Mobile Radio is turned on, the display shows XTL 5000.

The radio then performs a self check.

**Note:** If FL###/### (W4,W5,W7) or FAIL ##/### (W9) appears in the display, the radio will not function until the condition has been corrected.

If ER###/### (W4,W5,W7) or ERROR ##/### (W9) appears, some non-critical data has been changed. If either of these displays appear, if the display goes blank, or if the unit appears to be locked up, refer to the “Troubleshooting” section.

## Setting the Volume

Choose one of the following:

- **W4 Control Head:** Rotate the **Volume** knob clockwise to increase the volume and counterclockwise to decrease the volume.

A volume indication

**(0-15)** appears on the display; for example,  
VOL 10.

- **W5, W7, and W9 Control Heads:** Press and hold the **Vol** rocker switch.

A volume indication

**(0-15)** appears on the display. For example,  
VOL 10 (W5, W7) or VOLUME 10 (W9).

Hold the button until the sound level increases (or decreases) to the desired level.

---

## Adjusting the Display Brightness

Press the dimmer button (**Dim** on W4, or **DIM** on W5, W7, and W9) to change the display brightness to one of four levels:

- Off to high
- High to medium
- Medium to low
- Low to off.

In Off, both the display and backlight are off (used for surveillance operations).

---

## Trunked or Conventional

Depending on how your radio is programmed, you can select conventional channels or trunked talkgroup. Conventional channels consist of a transmit and receive frequency pair, an associated squelch code pair, and a time-out timer value. See “Conventional Radio Features” on page 57.

Trunked modes consist of the system/announcement group/talkgroup combination and a time-out timer value. See “Trunking Operation” on page 73.

## Field Programming

Other radio features may be slaved to the selected mode by field programming. This *mode slaving* means that the radio is preprogrammed to automatically give you the proper operation for each mode you select.

You may use the control head to program your own mode names. The names you assign are clearly shown in the alphanumeric display. You can see all the key operating information, including the mode selected or being scanned, and the on/off status of various features. The operating conditions are shown either by the display or by visual/audio indicators, or by both.

## Display Status

The control head display indicates your selected mode, or the currently active receive mode when scan is on.

## Feature Control

You can turn the various radio features on or off, change modes, and adjust the volume.

To exit a feature, such as phone, press the **HOME** button or the feature button (for example, **Phon**).

## Alert Tones

<i>Tone Type</i>	<i>Name</i>	<i>Description</i>
Two high-pitched tones	Private Conversation™	Indicate that a private call has been received.
Four high-pitched tones every six seconds	Call Alert	Indicate that a Call Alert page has been received.
Single, high-pitched tone	Central Acknowledge	Indicates that a Call Alert, emergency alarm, reprogram request, or status/message transmission has been received by the system's central controller.
Four high-pitched tones	Mobile Unit Acknowledge	Indicate that a Call Alert page has been received by the intended unit, or the emergency alarm, reprogram request, or status/message transmission has been acknowledged by the intended dispatcher.

<b><i>Tone Type</i></b>	<b><i>Name</i></b>	<b><i>Description</i></b>
Sound similar to a telephone busy signal	System Busy	Indicates, when you press the microphone push-to-talk (PTT) button, that you cannot transmit because all system radio channels are in use. Release the PTT button and wait for call back.
A series of three short, high-pitched tones	Automatic Call Back	Indicate that a channel is now available for your previously requested transmission.
A series of three short, high-pitched tones (same as automatic call back)	Talk Permit (optional)	Indicate, when you press the microphone PTT button, that the system is accepting your transmission.
Continuous, low-pitched tone	Talk-Prohibit/ Out-of-Range	Indicates, when you press the microphone PTT button, that either you are out of the range of the trunked radio system, or the system is out of service, or the channel is busy with the Smart PTT feature enabled.
Single, high-pitched tone every ten seconds	Failsoft	In an unmuted receive condition, indicates a trunked system central controller failure. The radio reverts from trunked operation to a system similar to conventional radio repeater operation. Other system users can be heard sharing the channel.

<b><i>Tone Type</i></b>	<b><i>Name</i></b>	<b><i>Description</i></b>
Continuous, low-pitched tone	Illegal Mode	Indicates that you have entered a mode where normal system traffic will be missed, or you are attempting something which is not permitted. Examples include: forgetting to exit the telephone interconnect mode after a call ends (fleet and subfleet calls cannot be received), attempting to transmit on a receive-only conventional mode, attempting to select a dynamic mode where no dynamic ID assignment has been made.
Brief tone	Volume-Set Tone	Indicate the volume level when you press the <b>Vol</b> rocker switch on a quiet channel (W5, W7, and W9 control heads only).
Brief low-pitched tone	Time-Out Timer Warning	Indicates that your present transmission will soon be disabled.
Single, short, high-pitched tone	Valid Key	Indicates that you pressed a valid key, or you entered a feature configuration state, or you are receiving or transmitting in the clear mode on secure models (with TX Clear Alert Tones enabled).
Single, low-pitched tone	Invalid Key	Indicates that you tried to make an invalid key press, or that an emergency alarm, reprogram request, or status/message was not acknowledged.
Unique chirping sound	Dynamic Reprogramming	Indicates that a dynamic ID is assigned.

# Basic Operating Procedures

---

## Basic Functions

This chapter shows you how to access the radio's basic functions and includes the following topics:

- Selecting the Zone or Mode (page 12)
- Selecting the Home Mode (page 14)
- Transmitting (Conventional Modes Only) (page 15)
- Transmitting (Trunked Modes Only) (page 15)
- Selecting the Transmit Power Level (page 16)
- Monitoring Conventional Mode Activity (page 17)
- Adjusting the Squelch Level (page 18)

## Selecting the Zone or Mode

A zone is a grouping of modes. A mode is a group of characteristics such as transmit/receive frequencies, Private-Line™ codes, radio parameters, and an alphanumeric name.

## Selecting or Changing the Zone

Press the ▲ (Zone up) button or ▼ (Zone down) button.

---



## Selecting or Changing a Mode in the Current Zone

To access a mode in the current zone, do one of the following:

- **W4 Control Head:** Turn the **Mode** knob until the display shows the desired mode name.
  - **W5 Control Head:** Press the **Mode** rocker switch until the display shows the desired mode name.
  - **W7 and W9 Control Heads:**
    - 1 Press and hold **HOME**. The zone/mode flashes.
    - 2 Release **HOME**.
    - 3 Enter the number by the keypad, and press **HOME** again.
- 

## Selecting or Changing to a Mode Not in the Current Zone

- 1 To access a mode that is not in the current zone, press the Zone up ▲ button or Zone down ▼ button to move to the zone containing the mode.

**Note:** The Zone up ▲ and Zone down ▼ buttons are optional buttons included with the radio when zone/mode is ordered.

- 2 Do one of the following:
    - **W4 Control Head:** Turn the **Mode** knob to select the desired mode.
    - **W5, W7, and W9 Control Heads:** Press the **Mode** rocker switch to select the desired mode.
-

## Selecting the Home Mode

This feature must first be enabled by a qualified radio technician.

Press **Home** (W4, W9) or **HOME** (W5, W7) to select the home mode contained within the home zone, from any other zone and mode in the radio.

---

## Transmitting (Conventional Modes Only)

- 1 Lift the microphone off-hook, and listen for activity on that mode.
  - 2 If you hear no activity, press and hold the microphone **PTT** button.
- 

## Transmitting (Trunked Modes Only)

- 1 Lift the microphone off-hook, and press the microphone **PTT** button.
- 2 Do one of the following:
  - If you hear three quick tones, or if you hear no tone and the red **XMIT** (transmit) indicator lights steadily, proceed with your message.

Release the **PTT** button to receive.

**OR**

- If you hear a continuous low-pitched tone, you are out of the system's range.

The red **XMIT** indicator may flash several times as the radio tries to access the system.

Release the **PTT** button and try again when the vehicle is driven within range of the system.

---

## Selecting the Transmit Power Level

The **L PWR** button lets you select (toggle) the transmit power level.

Press **L PWR**.

The display momentarily shows **LOW PWR** or **HIGH PWR** (W4, W5, W7), or **LOW POWER** or **HIGH POWER** (W9) to indicate the transmit power level selected.

Also, when low-power transmission is selected, the **L PWR** indicator lights.

---

## Monitoring Conventional Mode Activity

This feature allows you to monitor channel traffic on conventional channels by defeating the coded squelch. This feature must first be enabled by a qualified radio technician or system administrator.

Do one of the following:

- Take the microphone off hook (This is the same as monitor on. You hear all channel traffic.),

**OR**

- **W4, W5, and W7** Control Heads: Pressing **Mon** momentarily toggles between `MON ON` and `MON OFF`.

`MON ON` shown on the display indicates that the radio is monitoring.

- Pressing **Mon** again turns monitor off and you don't hear all channel traffic.
- **W9** Control Head: Press **Sql** momentarily.

`MONITOR ON` shown on the display indicates that the radio is monitoring.

---

## Adjusting the Squelch Level

1 Choose one of the following:

- **W4, W5, and W7** Control Heads: Press and hold **Mon**.  
The display shows **SQL XX**; where **XX** is a squelch level setting of **0** to **15**.
- **W9** Control Head: Press and hold **Sql** momentarily.

The display shows **SQUELCH XX**, where **XX** is a squelch level setting of **0** to **15**.

- 2 Adjust the squelch level by turning the **Mode** knob (W4) or by pressing the **Mode** rocker switch (W5, W7, W9) to reach the desired squelch level setting.
- 3 Press **Home** (W4, W9) or **HOME** (W5, W7) to return to the selected channel.
-

# General Radio Features

---

## Often-used Features

This chapter shows you how to access the most frequently used features. The following topics are covered:

- Emergency Call and Alarm (page 20)
- Scan Operation (page 26)
- Optional External Alarms (Horn and Lights) (page 36)
- Time-Out Timer (page 40)
- Push-To-Talk Identification (PTT-ID) (page 40)
- Telephone Interconnect List (Conventional and Trunking) (page 41)
- Call Alert Page (Conventional and Trunking—Digital Modes Only) (page 50)

## **Emergency Call and Alarm**

The emergency call and alarm features allow you to have priority channel access and/or send an emergency data transmission to the dispatcher in an emergency situation.

The desired type of emergency feature—alarm, call, call and alarm, or silent alarm—can be preprogrammed by a qualified radio technician.

The radio must be turned on to activate any emergency feature.

### **Emergency Call**

Emergency call gives you priority access to a voice channel for all subsequent transmissions after you press the emergency button. The level of priority access is determined by the system manager.

#### **SmartZone® Emergency Call Receive Operation**

A radio configured for SmartZone operation displays `EMER RCV` whenever it receives an emergency call. The display alternates with the selected-mode display as long as the radio is unmuted to the emergency call.



## Initiating an Emergency Alarm

The emergency alarm feature sends a data transmission to alert the dispatcher of your emergency condition and identify your unit ID.

Press the emergency button.

A tone sounds and the display alternates EMERGENCY (W4, W5, W7) or EMERGENCY (W9) with the current zone/channel.

**For trunking modes**, a high-pitched tone indicates that the alarm has been received by the trunked system's central controller.

A dispatcher acknowledgment (four high-pitched tones) and an ACK RCVD display follow.

The radio automatically returns to normal operation. No further action is required.

---

## Initiating an Emergency Call

- 1 Press the emergency button.

A tone sounds and the display alternates EMERGENCY (W4, W5, W7) or EMERGENCY (W9) with the current zone/channel.

- 2 Press the **PTT** button and announce your emergency.
- 3 After completing the emergency call, press and hold the emergency button until a tone sounds.

The alternating EMERGENCY (W4, W5, W7) or EMERGENCY (W9) display disappears, and the radio returns to normal operation.

---

## Initiating an Emergency Call and Alarm

If the radio has both emergency call and alarm features, it automatically proceeds to the call mode after the alarm is acknowledged.

- 1 Press the emergency button to activate the emergency call/ alarm feature.

The display begins alternating EMERGENCY (W4, W5, W7) or EMERGENCY (W9) with the current zone/channel.

**For trunking modes**, a high-pitched tone sounds, indicating that the alarm has been received by the trunked system's central controller.

A dispatcher acknowledgment (four high-pitched tones) follows, accompanied by an ACK RCVD display.

- 2 Press the **PTT** button and announce your emergency.
- 3 To exit from the emergency state altogether, press and hold the emergency button until a tone sounds.

The alternating EMERGENCY (W4, W5, W7) or EMERGENCY (W9) display disappears, and the radio returns to normal operation.

**Note:** Turning the radio off also cancels the emergency state.

---

## Initiating a Silent Emergency Alarm

- 1 Press the emergency button to activate the silent alarm feature.

During a silent emergency alarm, there are no display changes, and the receiver audio mutes so that no indication is given that an emergency alarm has been sent.

- 2 To exit the silent alarm mode, press and hold the emergency button until a tone sounds.

**Note:** If silent emergency alarm is used with emergency call, pressing the **PTT** button exits the silent mode and initiates the emergency call.

---

## Special Considerations for Emergencies

- If you press the emergency button while in a mode that has no emergency capability, a low-pitched tone sounds.
- If the unit is out of the range of the system and/or the emergency alarm is not acknowledged, a tone sounds and the display shows NO ACK.
- If you press the emergency button, then change to a mode that has no emergency capability, a NO EMERG (W4, W5, W7) or NO EMERGENCY (W9) display alternates with the mode name display, and a continuous low-pitched tone sounds until a valid emergency mode is selected or until the emergency is cancelled.
- When an emergency is active, changing to another mode where emergency is enabled (trunked or conventional) causes an emergency alarm and/or emergency call to be active on the new mode.

## Scan Operation

The scan feature allows you to monitor activity on different conventional or trunked modes by scanning a *scan list* of modes. The modes to be scanned in a scan list are programmed by a qualified radio technician. You can select the modes to be scanned in a scan list if *operator-selectable scan* is enabled.

There are three types of scan lists available:

- Conventional—Comprises up to 15 different conventional-only modes
- Trunked Priority Monitor—Comprises up to 15 modes that are all from the same trunked system
- Talkgroup Scan—Comprises up to 10 combined conventional modes and modes from one trunking system

The radio supports both priority and non-priority scanning. With priority scanning enabled, a scan list can have one mode assigned as the first-priority mode and a second as the second-priority mode.

The XTL 5000 Digital Mobile Radio supports automatic scanning (autoscan), which can be programmed into the radio by a qualified radio technician. With this feature, the radio begins scanning whenever you select a mode to which a scan list is assigned.

**Note:** You cannot turn scan off on a mode that has autoscan enabled.

If multiple scan types are enabled in the radio, the type of scan that is activated depends on the personality of the mode selected when

**Scan** is pressed. For all types of scan, the selected mode is, by default, a member of its own scan list.

Scan lists stay in memory when you turn scan off, turn the radio off, or disconnect the radio from the battery.

## Turning On Scan

Press **Scan** momentarily on a non-autoscan mode to start scanning.

The **Scan** indicator lights and a list of modes is scanned for activity.

When a scanned mode becomes active, the display changes to show the active mode name, the appropriate priority indicator lights, and the radio unmutes.

The radio will not begin scanning again for a predetermined *hang time* after the call ends, giving you time to respond. The hang time is typically three seconds (by default), but can be changed by a qualified radio technician.

**Note:** A lit **N PRI** (non-priority) indicator means that the active mode is a non-priority member of the scan list (for all scan types).

A solidly-lit **PRI** (priority) indicator means that the active mode is the priority 2 member of the scan list (Trunking Priority Monitor and Conventional scan types only).

A blinking **PRI** indicator means that the active mode is the priority 1 member of the scan list (Trunking Priority Monitor and Conventional scan types only).

---

## Turning Scan On While Disregarding the Squelch Code (Conventional Modes Only)

Choose one of the following:

- **W4, W5, and W7 Control Heads:** Press  momentarily. The brief **MON ON** display indicates that the radio is disregarding the squelch code.
- **W9 Control Heads:** Press  momentarily. The brief **MONITOR ON** display indicates that the radio is disregarding the squelch code.

**Note:** While scanning for activity, you can still receive fleetwide, system-wide, dynamic regrouping, incoming telephone interconnect and Private Conversation/Call Alert calls. Respond to these types of calls as you would normally on the selected mode. However, when scanning different modes while in talkgroup scan, incoming Private Conversation/Call Alert calls may be missed.

---



## Viewing a Scan List

- 1 Press and hold **Scan** until the **Scan** indicator blinks and a beep is heard.

The radio suspends scanning while a scan list is being reviewed.

- 2 Choose one of the following:
    - **W4 and W5 Control Heads:** Turn the **Mode** knob or press the **Mode** rocker switch to scroll up or down through the programmed modes. Those modes that are in the scan list are indicated by a **N PRI**, **PRI** or blinking **PRI** indicator (indicating the mode's assigned priority).
    - **W7 and W9 Control Heads:** Press the **Mode** rocker switch to scroll up or down through the programmed modes. Those modes that are in the scan list are indicated by a **N PRI**, **PRI** or blinking **PRI** indicator (indicating the mode's assigned priority as previously described). Press **Rcl** to review only the modes that are already in the scan list.
  - 3 Press **HOME** or **Scan** **Scan** momentarily to exit the scan list and resume scanning.
-

## Transmitting While Scan Is On

### Radio Programmed for Talkback Scan

Press the microphone **PTT** button to transmit on the mode indicated by the display.

The radio does not begin scanning again for a predetermined hang time (programmable by a qualified radio technician) after you release the **PTT** button, allowing the other party to respond.

If the other party responds within the hang time, scanning does not resume until the full hang time expires after they have finished speaking, allowing the conversation to be completed.

**Note:** To transmit on the selected channel if another channel is active, first turn scan off by pressing Scan momentarily.

---

### Radio Programmed for Non-Talkback Scan

In selected mode or fixed mode, press the microphone **PTT** button at any time to transmit on the selected mode or fixed mode.

**Note:** To make a Call Alert page, or Private Conversation call while scanning, press Page or Call. The call is entered on the selected mode and scanning is halted until the call is exited by pressing HOME or Page, or Call.

---

## Temporarily Deleting a Nuisance Mode With Scan On (W7 and W9 Control Heads Only)

To temporarily delete a mode that you do not wish to hear (nuisance mode), press  once while the mode is active (indicated by the display).

You can delete undesired modes.

**Note:** Priority modes, the selected mode, and the designated transmit mode cannot be deleted.

---

## Restoring a Nuisance Mode (W7 and W9 Control Heads Only)

To restore the original scan list, do one of the following:

- Press .
- Turn scan off, then on.
- Change modes.
- Turn off the radio, and then turn it back on.

**Note:** Nuisance mode delete can be disabled by the system administrator.

---

## Changing Mode Priorities While Scan Is On (W7 and W9 Control Heads Only)

When active, this dynamic priority feature allows you to change the priority of a non-priority mode in the scan list to priority 2.

To change the priority of a non-priority channel in the scan list to priority 2, press **Sel**.

You cannot alter the status of the priority 1 member.

---

## Restoring Mode Priorities in a Scan List (W7 and W9 Control Heads Only)

To restore the original mode priorities in a scan list, do one of the following:

- Press **Rcl**.
  - Turn scan off, then on.
  - Change modes.
  - Turn off the radio, and then turn it back on.
-

## Programming a Scan List

To program a scan list, operator-selectable scan list members first must be enabled in the radio programming by a qualified radio technician.

### Adding a Channel to the Scan List

- 1 Press and hold **Scan** until the scan indicator blinks and a good-key chirp is heard.
- 2 Using the **Mode** knob (W4) or **Mode** rocker switch (W5, W7, W9), locate the channel to be added.

**Note:** If the desired channel resides in a different zone, press the Zone up ▲ or Zone ▼ down button to change zones, then use the mode changer to find the desired channel.

- 3 Press **Sel** to add the channel.
- 4 Scroll through of the available priority choices, and press **Sel** to choose one.

The new channel becomes a member of the scan list assigned to the selected channel when scan list programming was entered.

**Note:** If a scan list is full, you will hear a bad-key chirp each time you press **Sel**, and the desired channel will not be assigned to the list.

- 5 Press either **Scan** or **HOME** to exit scan list programming and return to normal scan operation.
-

### Deleting a Channel from the Scan List

- 1 Press and hold **Scan** until the scan indicator blinks and a good-key chirp is heard.
- 2 Using the **Mode** knob (W4) or the **Mode** rocker switch (W5, W7, W9), locate the channel to be deleted.

**Note:** If the desired channel resides in a different zone, press the Zone up ▲ or Zone ▼ down button to change zones, then use the mode changer to find the desired channel.

- 3 Press **Sel** to scroll through the available priority choices until the priority choice disappears.

This indicates that the channel is no longer a member of the scan list that was assigned to the selected channel.

OR

Press **Rcl** momentarily to scroll through just the scan list members.

(Optionally for W7 and W9 Control Heads) Delete a channel from a scan list by pressing **Del**.

**Note:** If you delete all members of a scan list, and scan is subsequently turned on, you will hear a continuous low-pitched tone, and the display will change to NO LIST (W4, W5, W7) or EMPTY LIST (W9).

You cannot delete the designated transmit mode, the selected mode, or the fixed scan list members. The selected mode, by default, is always scanned when scan is turned on, regardless of whether or not it is explicitly programmed as a scan list member.

- 4 Press **Scan** or **HOME** to exit scan list programming and return to normal scan operation.
-

## Hang Up Box (HUB)

Remove the microphone from the Hang Up Box (HUB) to temporarily suspend Scan Mode operation. You are allowed to use the microphone while scan is suspended. Priority Member scanning is **not** suspended, however. This feature applies to all Scan Lists and Scan Types. Scan is resumed once the microphone is returned to the holding clip and the preprogrammed hang time has elapsed.

**Note:** Priority Scan List members are continuously scanned only when the Scan List, **Designated Tx Member** field is set to "Talkback" in the radio programming. Otherwise, all scan mode operation is suspended.

## Optional External Alarms (Horn and Lights)

All control heads can be equipped for external alarms (horn and lights) that are activated when a Call Alert page, Private Conversation call, or phone call is received.

These features are useful when you must leave the vehicle, but need to receive any incoming messages.

The radio always powers up with the horn and lights feature enabled.

## Activating the External Alarm(s)

### Non-Permanent Horn and Lights

- 1 Press  momentarily.

The last selected alarm(s) are enabled, and the display alternately shows the enabled alarm(s), then the selected mode.

- 2 Press  a second time to turn off the alarm(s).
-



### Permanent Horn and Lights

- 1 Press  momentarily.

The last selected alarm(s) are enabled.

The display briefly shows the enabled alarms, and then reverts back to the selected mode.

- 2 Press  a second time to turn off the alarm(s).
-

## Changing the Selected Alarms

- 1 Press and hold H/L until a tone sounds and the display indicates the currently selected alarm.
  - 2 Turn the **Mode** knob (W4) or press the **Mode** rocker switch (W5, W7, W9) to review the choices until the display shows the desired alarm:
    - HORN ON
    - LITES ON (W4, W5, W7) or LIGHTS ON (W9)
    - H/L ON (both horn and lights)
  - 3 Press HOME or H/L to select the desired alarm and return to normal operation.
-

## Receiving a Call While Alarms Are Turned On

When a call is received, the vehicle's horn sounds for four seconds, and/or the car lights turn on for 60 seconds. The time interval can be modified by a qualified radio technician.

The display alternates between the type of call received (**CALL**, **PAGE**, or **PHONE**) and the selected mode name.

### Turning Off Non-Rearmable External Alarm

- 1 To turn off the external alarm(s), press the **PTT** button or any control-head button.

**Note:** Pressing , , or  will turn off the external alarm(s) and place you directly in that feature.

The **Vol** rocker switch (or knob) and the **Dim** button have no effect on the state of the external alarm(s).

- 2 To rearm the horn and lights feature, press  momentarily.
- 

### Turning Off Rearmable External Alarms

To turn off the external alarm(s), press the **PTT** button or any control head button other than the **H/L** button.

Pressing , , or  turns off the external alarm(s) and places you directly in that feature. When the external alarm(s) are turned off, they will be automatically rearmed.

**Note:** Pressing  turns off the external alarm(s) and exits the horn and lights feature. To re-arm the feature, press  momentarily.

The **Vol** rocker switch (or knob) and the **Dim** button have no effect on the state of the external alarms.

---

## Time-Out Timer

All ASTRO XTL 5000 Digital Mobile Radios provide a time-out timer function that prevents locking up a repeater or channel by prolonged keying of the transmitter. You cannot transmit longer than the preset timer setting. If you attempt to do so, the radio automatically stops your transmission, and you hear a talk-prohibit tone.

**Note:** You will hear a brief, low-pitched, warning tone four seconds before the transmission times out.

The timer is set for 60 seconds at the factory, but it can be reprogrammed by a qualified radio technician for between 15 and 465 seconds (7.75 minutes), in 15-second intervals, or it can be disabled entirely for each radio mode.

## Push-To-Talk Identification (PTT-ID)

When you press the PTT button to send a message, your radio ID number is transmitted as part of each voice message. This PTT-ID number is then shown on the receiving radio's display.

For the digital mode, the display shows up to eight right-justified digits.

Pressing **Call** erases the PTT-ID from the display.

The display conditions of PTT-ID must be programmed by a qualified radio technician.

## **Telephone Interconnect List (Conventional and Trunking)**

With any of the control heads, you can initiate and receive telephone calls if the system is properly equipped. All calls between the mobile operator and the land line are private, regardless of who initiates the call.

All control heads feature a phone list capability of up to 100 preprogrammed phone numbers. The radios can be programmed by a qualified radio technician so that a name can be assigned to each number in the list.

In addition to the 100 preprogrammed phone numbers, the W7 and W9 Control Heads feature unlimited dialing capability with their 12-button telephone keypad.

## Answering a Phone Call

When a phone call is received, telephone-type ringing sounds and the display shows PHONE CALL (W9) or PHN CALL (W4, W5, W7).

- 1 Press **Phon**.
  - 2 Press the **PTT** button to talk; release it to listen.
  - 3 When the call is completed, press **HOME** or **Phon** to hang up and return to normal operation.
- 

## Initiating a Telephone Call From the List

- 1 Press **Phon** momentarily to select the phone function.

**(All Control Heads)** A valid-key chirp is heard.

**(W4, W5, and W7 Control Heads Only)** The phone indicator lights.

The display shows the last number dialed or a blank scratchpad appearing as a series of dashes.

- 2 Turn the **Mode** knob (W4), or press the **Mode** rocker switch (W5, W7, W9) to locate the number you want to call.

The display first shows the name, and then the number.

- 3 Press **Sel** or the **PTT** button.

The display shows the number that is automatically dialed.

**Note:** If the number contains a programmed pause, the dialing pauses briefly when the display shows P. After the brief pause, the rest of the numbers are dialed.

If you are out of range of the trunked system, the display shows NO PHONE, and a continuous low-pitched tone sounds. Press **HOME** or **Phon** to resume normal operation.

If the trunked phone interconnect is in use or the phone interconnect is out of service, a telephone-type busy tone sounds, and the display shows PHON BSY (W4, W5, W7) or PHONE BUSY (W9). Your number is automatically dialed when the phone interconnect becomes available. If you hang up, you lose your place in the queue.

If the display shows PHON BSY (W4, W5, W7) or PHONE BUSY (W9) with a low-pitched tone rather than a telephone-type busy tone, the call is not queued. You must hang up and try again.

- 4 When your party answers, press the **PTT** button to talk, and release it to listen.
  - 5 When the call is completed, press **HOME** or **Phon** to hang up and return to normal operation.
-

## Unlimited Telephone Interconnect (W7 and W9 Control Heads Only)

### Calling a Phone Number Not in the List

- 1 Press **Phon** momentarily to select the phone function.

The **Phone** indicator lights (W7 only), and the display shows the last number dialed (W7 and W9).

- 2 Enter the desired phone number from the keypad.

The display updates as the numbers are entered.

**Note:** To include a pause in the dialing sequence, press the \* button followed by the # button. A P appears in the display.

To backspace, press the **Mode** down rocker switch once, or

**# Del** twice.

- 3 Press **Sel** or the microphone **PTT** button to automatically dial the number in the display.

**Note:** If the number contains a programmed pause, the dialing pauses briefly when the display shows P. After the brief pause, the rest of the numbers are dialed.

- 4 When your party answers, press the **PTT** button to talk, and release it to listen.



**Note:** If you are out of range of the trunked system, the display shows **NO PHONE**, and a continuous low-pitched tone sounds. Press **HOME** or **Phon** to resume normal operation.

If the trunked phone interconnect is in use or the phone interconnect is out of service, a telephone-type busy tone sounds, and the display shows **PHON BSY (W7)** or **PHONE BUSY (W9)**. Your number is automatically dialed when the phone interconnect becomes available. If you hang up, you lose your place in the queue.

If the display shows **PHON BSY (W7)** or **PHONE BUSY (W9)** with a low-pitched tone, rather than a telephone-type busy tone, the call is not queued. You must hang up and try again.

If your radio is programmed for *live over dial*, every digit pressed after the phone call is established is sent to the telephone system.

If your radio is programmed for *buffered over dial*, the digits pressed are entered into the radio's memory, and they are all sent together when the **PTT** button is next pressed. You cannot send digits and talk on the same **PTT** button press. If you press the **PTT** button to send the digits, you must release the **PTT** button and press it again to transmit.

**5** When the call is completed, press **HOME** or **Phon** to hang up and return to normal operation.

---

## Storing a Number in the List

- 1 Press and hold **Phon** to select the phone programming function.

The phone indicator flashes (W7 only).

- 2 Do one of the following:
  - Press the **Mode** rocker switch to locate the number you want to change.

**OR**

- Use the keypad to move directly to the phone number you want to change.

- 3 Press **Sel** to edit the number in the display.

- 4 Enter the new phone number on the keypad.

**Note:** To backspace, press the # button twice or the **Mode** down ▼ button once. Enter a pause by pressing the \* button, then the # button.

- 5 Press **Sel** to store the new number.

- 6 Do one of the following:

- Press **HOME** to return to normal radio operation.

**OR**

- Press **Phon** to return to normal phone operation.
-

## Edit a Name in the List (W7 and W9 Control Heads Only)

- 1 Press and hold **Phon** to enter **Phon** ID list programming.

The **Phon** indicator flashes and a high-pitched tone sounds.

- 2 Press the **Mode** rocker switch to locate the list member you want to change.

OR

Use the numbered keys to go immediately to the location of a member in the list. For example, press **2** to go to the second member in the list; press **1** and **0** to go to the tenth member in the list, and so on.

- 3 Change the characters or numbers using any of the numeric keys (**0** through **9**) and special function keys (**\***, **#**).

**Note:** The maximum number of characters permitted in a text line is **8** for W7 Control Head and **11** for W9 Control Head. If you try to add too many characters, you will hear a low-pitched tone.

To edit, do any or all of the following:

- To enter a character at the blinking cursor, refer to the table on page 49.

Press the key of the desired character the number of times shown in the table. For example, to enter the character **C**, press the **2** key three times.

- To leave a space in the text, press the **Mode** up ▲ rocker switch to move the blinking cursor to the next character position, and then enter the character.

- To delete characters, press the **Mode** down ▼ rocker switch to move backwards over existing characters.

When the last character on the display has been erased, press the **Mode** down ▼ rocker switch again to leave the name-edit mode, without making any changes, and begin the procedure again at step 2.

- 4 To save the changes, press and hold **Sel**.

**Note:** Press **Sel** momentarily to confirm changes to a number in the list.

- 5 Repeat steps 2 through 4 until you have modified all the desired names,

**OR**

Do one of the following:

- Press **HOME** to return to normal radio operation.

**OR**

- Press **Phon** to return to normal phone operation.

**Table 1: Entering Characters Using the Keypad**

Key	Number of times the key is pressed								
	1	2	3	4	5	6	7	8	9
0	0								
1	1								
2	A	B	C	2	a	b	c		
3	D	E	F	3	d	e	f		
4	G	H	I	4	g	h	i		
5	J	K	L	5	j	k	l		
6	M	N	O	6	m	n	o		
7	P	Q	R	S	7	p	q	r	s
8	T	U	V	8	t	u	v		
9	W	X	Y	Z	9	w	x	y	z
*	*	/	+	-					
#	#								

## **Call Alert Page (Conventional and Trunking— Digital Modes Only)**

The Call Alert feature allows a radio to selectively alert another radio, and to determine whether or not that radio received the alert. A Call Alert page can be initiated after an unsuccessful Private Conversation call or as a separate feature.

All Control Heads are capable of responding to a Call Alert initiated by another radio. The following further describes each Control Head's capability:

- **All Control Heads:** Feature a unique list of up to 100 preprogrammed ID numbers. A name can be assigned to each ID in the list for your convenience.

**W7 and W9 Control Heads:** In addition to a list of 100 IDs, these Control Heads feature unlimited Call Alert page capability using a full, 12-button keypad.

## Sending a Call Alert Page

- 1 Press **Page**.

The **Page** indicator lights and a valid-key chirp sounds.

The display shows the last transmitted/received unit ID number.

- 2 Select a radio in one of the following ways:

- **From the ID number list:**

- Do nothing if you want to call the unit ID currently displayed.

**OR**

- Use the prestored list by turning the **Mode** knob (W4) or by pressing the **Mode** rocker switch (W5, W7, W9) to locate the name/ID you want to call.

**OR**

- Press the **Mode** up ▲ rocker switch once, and then use the keypad to directly advance to the desired list member.

**OR**

- Enter, using the keypad, the ID of the desired unit.

**Note:** Using the keypad to enter the ID of another unit can only be accomplished from the first display shown when **Page** was entered. If the list has been entered, scroll to the first display.

- 3 Press **Sel** or the microphone **PTT** button.

The display changes to PLS WAIT (W4, W5, W7) or PLEASE WAIT (W9).

4 Choose one of the following:

- When the called radio acknowledges the page, four additional tones sound and the display changes to **ACK RCVD.**

The radio returns to normal operation.

- If you are out of the range of the system, a low-pitched tone sounds.

Try again by pressing the **PTT** button or **Sel**,

**OR**

Press **HOME** or **Page** button to return to normal operation.

- If, after six seconds, the called unit fails to acknowledge the alert, a low-pitched tone sounds and the display changes to **NO ACK.**

Try again by pressing the **PTT** button or **Sel**,

**OR**

Press **HOME** or **Page** button to exit.

---



## Answering a Call Alert Page

If you are not available when a caller sends you a Call Alert page, a `PAGE RCV` message and the caller's ID are left.

If the page also triggers an external alarm, the display shows `PAGE RCV` and four tones repeat every five seconds.

**1** Do one of the following:

- Make a normal dispatch call. Press the **PTT** button and ask about the page.

**OR**

- Press . The display shows the unit ID of the caller.

Press  to initiate an enhanced Private Conversation or the **PTT** button to initiate a Private Conversation call to the caller.

**Note:** Pressing any button, the **PTT** button, changing systems, or pressing  or  clears the `PAGE RCV` display. The original unit ID is retained until another Call Alert or Private Conversation call is received.

---

## Storing a Unit ID Number In the List (W7 and W9 Control Heads Only)

The Selective Call and Call Alert page features share the same prestored list of unit IDs.

- 1 Press and hold **Page** to review the list.

The **Page** indicator flashes and a valid-key chirp sounds.

- 2 Press the **Mode** rocker switch to locate the list member you want to change.
- 3 Press **Sel** to select the unit ID store function.
- 4 Enter the new unit ID number on the keypad.

**Note:** If you make an error, press the **Mode** down ▼ rocker switch or **#Del** to erase each incorrect digit.

- 5 Press **Sel** to store the new ID.
- 6 Repeat steps 2 through 5 until all the desired IDs have been entered.

**OR**

Do one of the following:

- Press **HOME** to return to normal radio operation.

**OR**

- Press **Page** to return to normal Call Alert operation.
-

## Editing a Name in the List (W7 and W9 Control Heads Only)

The Selective Call and Call Alert page features share the same prestored list of unit IDs.

- 1 Press and hold **Call**, **Page**, or **2Pge** to enter **Call** ID list programming.

The **Call** indicator flashes and a high-pitched tone sounds.

- 2 Press the **Mode** rocker switch to locate the list member you want to change.

OR

Use the numbered keys to go immediately to the location of a member in the list. For example, press **2** to go to the second member in the list; press **1** and **0** to go to the tenth member in the list, and so on.

- 3 Press and hold **Sel** to select the name- editing function.
- 4 Change the characters or numbers using any of the numeric keys (**0** through **9**) and special function keys (**\***, **#**).

**Note:** The maximum number of characters permitted in a text line is **8** for W7 Control Head and **11** for W9 Control Head. If you try to add too many characters, you will hear a low-pitched tone.

To edit, do any or all of the following:

- To enter a character at the blinking cursor, refer to the table on page 49.

Press the key of the desired character the number of times shown in the table. For example, to enter the character **C**, press the **2** key three times.

- To leave a space in the text, press the **Mode up** ▲ rocker switch to move the blinking cursor to the next character position, and then enter the next character.
- To delete characters, press the **Mode down** ▼ rocker switch to move backwards over existing characters.

When the last character on the display has been erased, press the **Mode down** ▼ rocker switch again to leave the name-edit mode, without making any changes, and begin the procedure again at step 2.

5 To save the changes, press and hold **Sel**.

**Note:** Press **Sel** momentarily to confirm changes to numbers in the list.

6 Repeat steps 2 through 5 until you have modified all the desired names,

**OR**

Do one of the following:

- Press **HOME** to return to normal radio operation.

**OR**

- Press **Page** to return to normal Call Alert operation.

# Conventional Radio Features

---

## Features Used in Conventional Operation

This chapter shows you how to access features available in conventional operation. The following topics are covered:

- Status Calls (Digital Modes Only) (page 58)
- Smart PTT (page 61)
- Conventional Talkgroup Calls (page 62)
- Conventional Talkaround (page 64)
- Selective Call (Digital Modes Only) (page 65)

## Status Calls (Digital Modes Only)

Radio status calls are used to inform the dispatcher of the present state of the mobile unit. For example, a status might be **ENROUTE** or **AT SITE**.

Status names are field programmable. Each radio can have up to 8 separate statuses.

### Sending a Status Call (W7 and W9 Control Heads Only)

- 1 Press  , and the display shows the last-acknowledged status name.
- 2 Press the **Mode** rocker switch to review the list of status names, or use the keypad to enter the number of the status you wish to send.

**Note:** If no button is pressed for a period of time, an inactivity warning will sound.

- 3 The display shows the desired status name or number, press  or the **PTT** button to send the transmission.

One of the following conditions occur:

- The radio display shows `PLS WAIT (W7)` or `PLEASE WAIT (W9)` until the transmission is received and acknowledged.

When the dispatcher acknowledges the status, four high-pitched tones sound, and the display shows `ACK RCVD`.

The radio then returns to normal dispatch operation.

- If the status is **not acknowledged** after approximately six seconds, the display alternates between `NO ACK` and the associated status name. A low-pitched tone also sounds continuously.

- If there is no acknowledgment, do one of the following:

Press the microphone **PTT** button or **Sel** to resend the status transmission.

**OR**

Press **HOME** to return to normal dispatch operation.

---

## Sending a Direct-Entry Keyboard (DEK) Status (Digital Modes Only)

Press the desired **Sts #** button on the DEK.

The red indicator flashes while the radio is waiting for an acknowledgment. The control head momentarily displays the selected status, then shows `PLS WAIT (W7)` or `PLEASE WAIT (W9)`.

One of the following conditions occur:

- When the dispatcher-acknowledge is received, four high-pitched tones sound, and the status indicator lights solid and remains on to show the last status acknowledged by the dispatch terminal.

The display also temporarily shows **ACK RCVD**.

The radio then returns to normal dispatch operation.

- If the dispatcher-acknowledge is not received, the red indicator continues to flash, the display temporarily shows **NO ACK**, and a low-pitched tone sounds. At the same time, the indicator above the last-acknowledged status lights.

The radio then returns to normal dispatch operation.

- Resend the last status.
-



## Smart PTT

Smart PTT is a per-mode feature that gives the system manager better control of radio operations. When smart PTT is enabled in your radio, you will not be able to transmit on an active mode. If you try to transmit (press the **PTT** button) on a busy or active smart PTT channel, a continuous tone sounds until you release the PTT button, and the transmission is inhibited.

The yellow **BUSY** LED lights when the radio is receiving to indicate that the mode is busy.

Three radio-wide variations of smart PTT can be enabled on your radio:

Transmit Inhibit on Busy Mode with Carrier	You will not be able to transmit if any activity is detected on the mode.
Transmit Inhibit on Busy Mode with Wrong Squelch Code	You will not be able to transmit on an active mode that has a squelch code other than your own.
Quick-Key Override	You can override either of the two previous transmit-inhibit states by quick-keying the radio (two quick PTT button presses).

## Conventional Talkgroup Calls

### Digital Modes Only

This feature allows you to define talkgroups for your conventional system. Talkgroups, combined with selective squelch operation, allow groups of users to transparently share a conventional channel.

Talkgroups can be slaved to a personality through programming, or you can select them.

Encryption keys are slaved to talkgroups. When conventional talkgroups are enabled, encryption keys are changed by changing the active talkgroup.

### Selecting a Conventional Talkgroup

The *Talkgroup Select* feature allows you to manually select any one of the available talkgroups.

- 1 Press the **Tgrp** button.  
The display changes to show the last-selected talkgroup.
- 2 Turn the **Mode** knob (W4) or the **Mode** rocker switch (W5, W7, W9) to choose a different talkgroup.

**(W7 and W9 Control Heads)** Talkgroups can be accessed by direct keypad entry.

- 3 Press  to save the talkgroup.

The radio returns to the home display.

**Note:** To select the default talkgroup, press **Sel** while the radio displays **PRESET**.

Selecting **PRESET** causes the radio to return to its preprogrammed talkgroup.

To abort the talkgroup menu, press **HOME** or the **PTT** button:

- Pressing **HOME** exits the talkgroup select menu without saving the selected talkgroup choice.
- Pressing the **PTT** button exits the menu without saving the selected talkgroup and allows the radio to transmit.

**Note:** If the encryption key slaved to the new talkgroup is erased, the display shows **KEY FAIL** and a momentary tone is generated. If the encryption key that is slaved to the new talkgroup is not allowed, the display shows **ILLEGAL KEY** and a momentary tone is generated.

---

## Conventional Talkaround

### Talk Direct (Mobile-To-Mobile)

To talk directly to another unit without going through the conventional repeater system:

- 1 Press  momentarily.

The **Dir** indicator lights, indicating that the radio is now transmitting directly to another unit.

- 2 To return to repeater operation, press  again.

The **Dir** indicator goes out.

**Note:** A conventional personality can be configured to always transmit on the direct mobile-to-mobile frequency. In this case, the **Dir** indicator is lit continuously while the mode is selected.

---

## Selective Call (Digital Modes Only)

The Selective Call feature not only allows you to carry on a conversation that is heard only by the two parties involved, but also enables you to determine whether the unit you are calling is in service.

All Control Heads are capable of responding to a Selective Call initiated by another radio. The following further describes each Control Head's capability:

- **All Control Heads:** Feature a unique list of preprogrammed ID numbers. A name may be assigned to each ID in the list for your convenience.
- **W7 and W9 Control Heads:** In addition to a list of IDs, these Control Heads feature unlimited enhanced Private Conversation (see page 74) capability using a full, 12-button keypad to call any ID in the system.

## Answering a Selective Call

When a Selective Call is received, two high-pitched tones sound and the display alternates between **CALL RCV** and the home display.

- 1 Press  within 20 seconds of receiving the call. (This time is programmable by a qualified radio technician.)

The display shows the ID number of the calling unit.

- 2 To respond to the call, press the **PTT** button and talk.

If 20 seconds pass before you press , you will not respond privately to the call just received. Instead, when you press , you enter the *Selective Call* state, as described in “Selective Call (Digital Modes Only)” on page 65.

If the system is busy when you attempt to answer the call, a telephone-type busy tone sounds and your radio's **BUSY** indicator lights. When a channel becomes available, you receive a call back, and your radio automatically keys up for three seconds so that you can begin talking.

- Note:** If you do not press  before pressing the PTT button, your conversation will be heard by all members of the talk group.
-

## Initiating a Selective Call

To initiate a Selective Call, select a unit to call, then place the call.

- 1 Press **Call**.

The **Call** indicator lights, and the display shows the last transmitted/received unit ID number.

- 2 Select a unit in one of the following ways:

- **From the ID number list:**

- Do nothing if you want to call the unit ID currently displayed.

**OR**

- Use the prestored list by turning the **Mode** knob (W4) or by pressing the **Mode** rocker switch (W5, W7, W9) to locate the name/ID you want to call.

**OR**

- Press the **Mode** up ▲ rocker switch once, and then use the keypad to directly advance to the desired list member.

**OR**

- Enter, using the keypad, the ID of the desired unit.

**Note:** Using the keypad to enter the ID of another unit can only be accomplished from the first display shown when **CALL** was entered. If the list has been entered, scroll to the first display.

- 3 Press **Sel** or the microphone **PTT** button.

A telephone-type ringing sounds if the unit you are calling is in service. The display shows **PLS WAIT** (W4, W5, W7) or **PLEASE WAIT** (W9).

- 4 Choose one of the following conditions that applies to your current call:
- If the receiving unit answers, identify yourself and begin your Selective Call.
  - If, after a programmable time period, you are not connected, the display shows **NO ACK** and a momentary, low-pitched tone sounds.

Try again, or press **HOME** or **Call** button to return to normal operation.

- If you are out of the system's range, a low-pitched tone sounds.

Try again, or press **HOME** or **Call** button to return to normal operation.

- If the system is busy when you attempt to make a call, the radio you are calling hears a telephone-type busy tone. When a channel becomes available, the called radio receives a call back and automatically keys up for three seconds so that conversation can begin.

- 5 To return to normal operation, press **HOME** or **Call** .

**Note:** If you do not press **HOME** or **Call** button to hang up, your unit will remain in the Selective Call state with the other unit. You will miss all subfleet traffic and incoming phone calls.

---



## Viewing Your Unit ID Number

- 1 Press **Call** momentarily to select the Selective Call feature.

The **Call** indicator lights.

- 2 Do one of the following:

- Turn the **Mode** knob (W4) counterclockwise or press the **Mode** down ▼ rocker switch (W5, W7, W9) to locate the **MY ID** display.

**OR**

- **W7 and W9 Control Heads only:** When not in the scratchpad, press the \* button.

The display will alternate between **MY ID** and your ID number.

- 3 To return to normal operation, press **HOME** or **Call** button.
-

## Storing a Unit ID Number in the List (W7 and W9 Control Heads Only)

The Selective and Call Alert page features share the same prestored list of units' IDs.

- 1 Press and hold **Call**, **Page**, or **2Pge** to review the **Call** ID list.

The **Call** indicator flashes and a high-pitched tone sounds.

- 2 Press the **Mode** rocker switch to locate the list member you want to change.
- 3 Press **Sel** to select the unit ID store function.
- 4 Enter the new unit ID number on the keypad.

**Note:** If you make an error, press the **Mode** down ▼ rocker switch or **#Del** to erase each incorrect digit.

- 5 When all the digits of the ID are entered, press **Sel** to store the new ID.
- 6 Repeat steps 2 through 5 until all the desired IDs have been entered.

**OR**

Do one of the following:

- Press the **HOME** to return to normal radio operation.

**OR**

- Press **Call** to return to normal Call operation.
-

## Editing a Name in the List (W7 and W9 Control Heads Only)

The Selective Call and Call Alert page features share the same prestored list of unit IDs.

- 1 Press and hold **Call**, **Page**, or **2Pge** to enter the **Call** ID list.

The **Call** indicator flashes and a high-pitched tone sounds.

- 2 Press the **Mode** rocker switch to locate the list member you want to change.

OR

Use the numbered keys to go immediately to the location of a member in the list. For example, press **2** to go to the second member in the list; press **1** and **0** to go to the tenth member in the list, and so on.

- 3 Press and hold **Sel** to select the name-editing function.
- 4 Change the characters or numbers using any of the numeric keys (**0** through **9**) and special function keys (**\***, **#**).

**Note:** The maximum number of characters permitted in a text line is **8** for W7 Control Head and **11** for W9 Control Head. If you try to add too many characters, you will hear a low-pitched tone.

To edit, do any or all of the following:

- To enter a character at the blinking cursor, refer to the table on page 49.

Press the key of the desired character the number of times shown in the table. For example, to enter the character **C**, press the **2** key three times.

- To leave a space in the text, press the **Mode** up ▲ rocker switch to move the blinking cursor to the next character position, and then enter the next character.
- To delete characters, press the **Mode** down ▼ rocker switch to move backwards over existing characters.

When the last character on the display has been erased, press the **Mode** down ▼ rocker switch again to leave the name-edit mode, without making any changes, and begin the procedure again at step 2.

5 To save the changes, press and hold **Sel**.

**Note:** Press **Sel** momentarily to confirm changes to a number in the list.

6 Repeat steps 2 through 6 until you have modified all the desired names.

**OR**

Do one of the following:

- Press **HOME** to return to normal radio operation.

**OR**

- Press **Call** to return to normal Call operation.

# Trunking Operation

---

## Features Used on Trunking Systems

This chapter shows you how to access features available on trunking systems. The following topics are covered:

- Enhanced Private Conversation (Digital Modes Only) (page 74)
- Failsoft (page 81)
- Dynamic Regrouping (Digital Modes Only) (page 82)
- SmartZone® (W7 and W9 Control Heads Only) (page 85)
- Out-of-Range Indication (page 89)
- Trunked Announcement (page 90)

## Enhanced Private Conversation (Digital Modes Only)

The enhanced Private Conversation feature not only allows you to carry on a conversation that is heard only by the two parties involved, but also enables you to determine whether the unit you are calling is in service.

All Control Heads are capable of responding to a Private Conversation call initiated by another radio. The following further describes each Control Head's capability:

- **All Control Heads:** Feature a unique list of preprogrammed ID numbers. A name may be assigned to each ID in the list for your convenience.
- **W7 and W9 Control Heads:** In addition to a list of IDs, these Control Heads feature unlimited enhanced Private Conversation capability using a full, 12-button keypad to call any ID in the system.

## Answering an Enhanced Private Conversation Call

When a Private Conversation Call is received, two high-pitched tones sound and the display alternates between **CALL RCV** and the home display.

- 1 Press  within 20 seconds of receiving the call. (This time is programmable by a qualified radio technician.)

The display shows the ID number of the calling unit.

- 2 To respond to the call, press the **PTT** button and talk.

If 20 seconds pass before you press , you will not respond privately to the call just received. Instead, when you press , you enter the *Private Conversation Call* state, as described in “Initiating an Enhanced Private Conversation Call” on page 76.

If the system is busy when you attempt to answer the call, a telephone-type busy tone sounds and your radio’s **BUSY** indicator lights. When a channel becomes available, you receive a call back, and your radio automatically keys up for three seconds so that you can begin talking.

**Note:** If you do not press  before pressing the PTT button, your conversation will be heard by all members of the talk group.

---

## Initiating an Enhanced Private Conversation Call

To initiate an Enhanced Private Conversation Call, select a unit to call, then place the call.

- 1 Press **Call**.

The **Call** indicator lights, and the display shows the last transmitted/received unit ID number.

- 2 Select a unit in one of the following ways:

- **From the ID number list:**

- Do nothing if you want to call the unit ID in the display.

**OR**

- Use the prestored list by turning the **Mode** knob (W4) or by pressing the **Mode** rocker switch (W5, W7, W9) to locate the name/ID you want to call.

**OR**

- Press the **Mode up** ▲ rocker switch once, and then use the keypad to directly advance to the desired list member.

**OR**

- Enter, using the keypad, the ID of the desired unit.

**Note:** Using the keypad to enter the ID of another unit can only be accomplished from the first display shown when **CALL** was entered. If the list has been entered, scroll to the first display.

- 3 Press **Sel** or the microphone **PTT** button.

A telephone-type ringing sounds if the unit you are calling is in service. The display shows **PLS WAIT** (W4, W5, W7) or **PLEASE WAIT** (W9).



---

**4** Choose one of the following conditions that applies to your current call:

- If the receiving unit answers, identify yourself and begin your Private Conversation.
- If, after a programmable time period, you are not connected, the display shows **NO ACK** and a momentary, low-pitched tone sounds.

Try again, or press **HOME** or **Call** button to return to normal operation.

- If you are out of the system's range, a low-pitched tone sounds.

Try again, or press **HOME** or **Call** button to return to normal operation.

- If the system is busy when you attempt to make a call, the radio you are calling hears a telephone-type busy tone. When a channel becomes available, the called radio receives a call back and automatically keys up for three seconds so that conversation can begin.

**5** To return to normal operation, press **HOME** or **Call** .

**Note:** If you do not press **HOME** or **Call** button to hang up, your unit will remain in the Private Conversation state with the other unit. You will miss all subfleet traffic and incoming phone calls.

---

## Storing a Unit ID Number In the Private Conversation List (W7 and W9 Control Heads Only)

The Private Conversation and Call Alert page features share the same prestored list of unit IDs.

- 1 Press and hold **Page** to review the list.

The **Page** indicator flashes and a valid-key chirp sounds.

- 2 Press the **Mode** rocker switch to locate the list member you want to change.
- 3 Press **Sel** to select the unit ID store function.
- 4 Enter the new unit ID number on the keypad.

**Note:** If you make an error, press the **Mode** down ▼ rocker switch or **#Del** to erase each incorrect digit.

- 5 Press **Sel** to store the new ID.
- 6 Repeat steps 2 through 5 until all the desired IDs have been entered.

**OR**

Do one of the following:

- Press **HOME** to return to normal radio operation.

**OR**

- Press **Page** to return to normal Call Alert operation.
-

## Editing a Name in the Private Conversation List (W7 and W9 Control Heads Only)

The Private Conversation and Call Alert page features share the same prestored list of unit IDs.

- 1 Press and hold **Call**, **Page**, or **2Pge** to enter **Call** ID list programming.

The **Call** indicator flashes and a high-pitched tone sounds.

- 2 Press the **Mode** rocker switch to locate the list member you want to change.
- 3 Press and hold **Sel** to select the name- editing function.
- 4 Change the characters or numbers using any of the numeric keys (**0** through **9**) and special function keys (**\***, **#**).

**Note:** The maximum number of characters permitted in a text line is **8** for W7 Control Head and **11** for W9 Control Head. If you try to add too many characters, you will hear a low-pitched tone.

To edit, do any or all of the following:

- To enter a character at the blinking cursor, refer to the table on page 49.

Press the key of the desired character the number of times shown in the table. For example, to enter the character **C**, press the **2** key three times.

- To leave a space in the text, press the **Mode** up ▲ rocker switch to move the blinking cursor to the next character position, and then enter the next character.

- To delete characters, press the **Mode** down ▼ rocker switch to move backwards over existing characters.

When the last character on the display has been erased, press the **Mode** down ▼ rocker switch again to leave the name-edit mode, without making any changes, and begin the procedure again at step 2.

- 5 To save the changes, press and hold **Sel**.
- 6 Repeat steps 2 through 5 until you have modified all the desired names,

**OR**

Do one of the following:

- Press **HOME** to return to normal radio operation.

**OR**

- Press **Page** to return to normal Call Alert operation.

## Failsoft

If the trunked system's central controller fails for any reason, the radio indicates *failsoft*. In this condition, the radio transmits and receives on a pre-determined frequency in a conventional mode.

Failsoft ensures that you will have communications capability at all times. Radios can be programmed by the system administrator so units that normally communicate on the same trunked mode will be assigned to the same failsoft repeater frequency.

Since the normal trunking features do not operate during failsoft, much of the privacy of trunked systems is lost. You must share the channel with other users until the failure is corrected.

To continue, in Failsoft, to communicate with other talkgroups:

- 1 Rotate the **Mode** knob (W4) or press the **Mode** (W5, W7, W9) rocker switch to change to a different repeater frequency.

The failsoft condition is indicated by a faint beeping tone every ten seconds (radio unscelched).

When the trunking system returns to normal operation, the beeping tone stops.

- 2 Press the **PTT** button to talk, and release the button to listen.
- 

Failsoft:

If a system that is in failsoft is accessed while in scan, the radio freezes scan and remains on the failsoft frequency for a period of six seconds. This time period can be changed by a qualified radio technician. This allows the operator to monitor the failsoft frequency for activity before resuming scanning.

On W7 and W9 Control Heads, the nuisance-delete feature can be used to temporarily delete the system in failsoft from the scan list, if desired.

## Dynamic Regrouping (Digital Modes Only)

The dynamic regrouping feature allows the dispatcher to temporarily reassign selected individuals, operating in separate trunked talkgroups, into a single group so that they can communicate.

### Receiving a Dynamic Regrouping ID Assignment (W7 and W9 Control Heads Only)

When your unit receives a dynamic regrouping ID assignment, a unique chirp sounds to alert you that your unit has been dynamically regrouped. The display shows the new dynamic mode name assignment. Examples of the field-programmable dynamic mode names include 16 DYNMC, 8 TACTCL.

- Press the **PTT** button. The radio makes a chirp and transmits on the dynamically assigned mode.

After the dispatcher releases your mobile from the dynamic ID assignment, your radio returns to the last selected, non-dynamic regrouping mode.

- If no dynamic regrouping assignment has been made, a low-pitched tone sounds if you attempt to select a dynamic mode.
-

---

## Selecting Enable and Disable (Digital Modes Only)

The dispatcher may classify regrouped units into one of two categories: *select-enabled* or *select-disabled*.

**Select-enabled** Units are free to make mode changes to any of the available talkgroups, including the dynamic group.

**Select-disabled** Units cannot change modes because the dispatcher has specifically chosen to force the unit to remain in the dynamic mode.

## Requesting a Dynamic Regrouping (W7 and W9 Control Heads Only) (Digital Modes Only)

Press  (W7) or  (W9) to request regrouping.

A high-pitched tone sounds, indicating your request was received by the system's central controller.

The display changes to `RPGM` (W7) or `RPGM RQST` (W9) while the request is being processed.

If the regrouping request is **acknowledged**, a dispatcher-acknowledge signal sounds (four high-pitched tones), and the display shows `ACK RQVD`.

The radio then returns to normal operation.

If the regrouping request is ***not acknowledged*** within six to eight seconds, the display alternates between showing NO ACK and RPGM or (W9 Control Head) RPGM RQST, and a low-pitched tone sounds.

At this time, do one of the following:

- Press the microphone **PTT** button or Sel to resend the regroup request.

OR

- Press HOME to return to normal operation.
-



## SmartZone<sup>®</sup> (W7 and W9 Control Heads Only)

The SmartZone feature extends communications beyond the reach of a single-trunked site (antenna location) when operating in a SmartZone system. SmartZone units provide expanded wide-area coverage.

SmartZone automatically switches the radio to a different site when the current site signal becomes unacceptable. This usually happens when the vehicle in which the radio is located is driven out of the range of one site, and into the range of another.

Under normal conditions, a SmartZone-enabled radio functions invisibly to the operator. However, the operator does have some manual controls on the W7 and W9 Control Heads: the **Site** and **Lock** buttons. These buttons can be used to check, or change, the SmartZone operation.

## Site-Button Operation

To check which site the radio has currently selected:

Press **Ste** (W7) or **Site** (W9) momentarily.

The display momentarily shows the current site name and RSSI (received signal strength indicator).

One of the following conditions can also occur:

- If the radio is not locked onto a site, but is scanning for a new site, the display shows `SCANNING`.
- If the radio has not yet received site ID information for the current site, the radio displays `SITE XX`.

**Note:** You can also initiate scanning to another site by holding down **Ste** until the display shows `SCANNING`.

---

## Locking Onto a Site

In areas that commonly have weak signals, use the SmartZone lock function to prevent the radio from automatically scanning for a new site.

- 1 Press **Lck** (W7) or **Lock** (W9) momentarily to display the current lock status.

**W7 Control Head:** Either the display shows LOCKED or UNLOCKED.

**W9 Control Head:** Either the display shows SITE LOCKED or SITE UNLCKD.

- 2 To change the locked or unlocked condition, press and hold **Lck** (W7) or **Lock** (W9) until a tone sounds and the display changes.

After temporarily displaying the new condition, the radio returns to normal operation.

---

## Site Trunking

In a SmartZone system, if the zone controller for a particular site fails, the site enters into a site-trunking operational mode. In this mode of operation, the user can only communicate with other units at the same site.

Radios in a SmartZone system can be programmed by a qualified radio technician to display `STE TRNK (W7)` or `STE TRUNK (W9)` when site trunking becomes active. The display alternates with the current mode display as long as the radio remains in site trunking. The radio also sounds a valid-key chirp when it first detects site trunking.

## Out-of-Range Indication

The out-of-range display/audible indication feature can be enabled by a qualified radio technician. The display alternately shows **OUT OF RANGE** and the current selected mode, and a low-pitched tone sounds every six seconds:

- When the radio is out of range of the system and can no longer lock onto the control channel

### **OR**

- When the radio is in failsoft and cannot lock onto the failsoft channel.

The out-of-range indication remains in effect until one of the following conditions occur:

- The radio locks on a control channel
- The radio locks on a failsoft channel
- The radio is turned off

## Trunked Announcement

The announcement capability allows a user to make announcements to the entire user group, as well as monitor talkgroup calls and other announcements.

Announcement calls are handled in two different ways, depending on the trunked central controller configuration. The two types are called *ruthless* and *non-ruthless* preemption.

- **Ruthless Preemption:** When a ruthless preemption announcement call is initiated, the requesting radio begins transmitting immediately. All associated talkgroup calls taking place on other channels are immediately halted, and the radios are steered to the announcement call.

Transmitting radios continue to transmit until the PTT button is released, at which time they also unmute for the announcement call. Individual calls (Private Conversation and telephone interconnect) are not affected.

- **Non-Ruthless Preemption:** When a non-ruthless preemption announcement is initiated, the initiating unit receives a telephone-type busy tone, followed by a call back when all associated talkgroup conversations end.

Once an announcement call is pending, any attempts by other users to initiate a talkgroup call will result in a telephone-type busy tone. These users will not receive a call back until the announcement call is complete.

## Initiate an Announcement

If your radio has been programmed to allow announcement calls:

- 1 Turn the **Mode** knob (W4) or press the **Mode** rocker switch (W5, W7, W9) to locate the announcement-group mode.
  - 2 Press the microphone **PTT** button to initiate the announcement.
-





# Secure Operation

---

## Features Available on Secure XTL 5000

This chapter covers features available on XTL 5000 Digital Mobile Radios with secure encryption. The following topics are covered:

- Receiving a Private Message (page 94)
- Transmitting a Private Message (page 94)
- System Considerations (page 95)
- Loss Indication (page 96)
- Selecting an Encryption Key (Conventional Only) (page 97)
- Selecting an Encryption Index (Conventional Only) (page 99)

## Receiving a Private Message

- 1 Select a mode by turning the **Mode** knob (W4) or pressing the **Mode** rocker switch (W5, W7, W9).
- 2 Using the **Volume** knob (W4) or the **Vol** rocker switch (W5, W7, W9), adjust the volume to a comfortable listening level.

In conventional modes and, if enabled, in trunking modes, the **BUSY** light blinks and the radio unmutes when the radio is receiving a private message.

**Note:** The secure on/off state does not affect received messages. The radio automatically receives coded or clear messages.

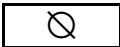

---

## Transmitting a Private Message

- 1 Press  to turn on the coded mode.

Some radio modes may have secure automatically set on or off if the *mode-strapped Secure* feature is enabled.

The display shows the current key if *multi-key* has been enabled.

- Note:** If the coded mode is selected, the  is on. If the standard (clear) mode is selected, the  indicator is off.
- 2 Monitor the mode to be sure it is not in use.
  - 3 Press and hold the **PTT** button to transmit.

The **XMIT** indicator lights, and the display shows the current key selected when transmitting in the coded mode, if *multikey* and *Display on PTT* are enabled.

---

## System Considerations

- **Trunked Systems only:** If you press the **PTT** button when no secure-voice channel is available, the display shows **NO SEC** (W4, W5, W7) or **NO SECURE** (W9), and a continuous talk-prohibit tone sounds until you release the **PTT** button.
- **Analog trunking systems:** You **are not allowed** to change from a secure transmission to a clear transmission during a secure trunked call. If you attempt to change from a secure to a clear transmission during a call, the radio generates a talk-prohibit tone, and the display will show **SEC ONLY** or **SECURE ONLY**.
- **Digital trunking systems:** You **are allowed** to change from a secure transmission to a clear transmission during a secure trunked call.

## Loss Indication

When you press the PTT button while in the coded mode and without the encryption module containing a valid key, the speaker generates bursts of alert tones, and the display shows `KEY FAIL` until you release the PTT button.



When the radio is first turned on, six medium-pitched tones sound and the display momentarily shows `KEY FAIL` to indicate that the encryption module does not contain a valid key for the current mode.

If the periodic keyfail tone feature is enabled, six medium-pitched tones are generated every five to ten seconds while the radio is not transmitting or receiving to remind you that the radio does not have a valid key for the current mode. The keyfail reminder will not sound when the radio is in clear mode.

## Selecting an Encryption Key (Conventional Only)

The Select Key feature allows you to manually select any one of the 16 encryption keys.

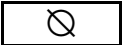
If the current mode is programmed with key selection being strapped to force the current mode to use a predetermined key, the Select Key menu will not appear as a Secure menu item.

- 1 Press and hold down  until a tone sounds, which indicates entry into the Advanced Secure menu.
- 2 Turn the **Mode** knob (W4) or press the **Mode** rocker switch (W5, W7, W9) to locate the KEY SEL option.
- 3 Press  to enter the Key Selection menu.

The display changes to show the last user-selected key.

- 4 Do one of the following:
  - Turn the **Mode** knob (W4) or press the **Mode** rocker switch (W5, W7, W9) to review the encryption keys,

**OR**

- Use direct keypad entry to access the encryption keys.
- 5 Choose one of the following:

- To save a key, press .

The radio returns to the home display.

- To select the default encryption keys on a radio-wide basis, press  while the radio displays PRESET.

Selecting preset causes the radio to return to its preprogrammed keys on a per-zone/-mode basis.

**Note:** When you scroll to an erased key, the display alternates between the key name and ERASED.

**6** To abort this menu, press **HOME** or the **PTT** button.

Pressing **HOME** exits the key-select menu without saving the selected key choice.

Pressing the **PTT** button exits the menu without saving the selected key choice and allows the radio to transmit.



When you abort the key-select menu, the radio uses the key that was selected prior to entry into the menu.

---

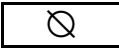

## Selecting an Encryption Index (Conventional Only)

The *Select an Index* feature allows you to select one or more groups of several encryption keys from among the available keys stored in the radio. For example, you could have a group of three keys structured to one index, and another group of three different keys structured to another index. By changing indices, you would automatically switch from one set of keys to the other.

If the mobile does not support indexing, the index menu will not appear as a Secure menu item.

- 1 Press and hold down  until a tone sounds, which indicates entry into the Advanced Secure menu.
- 2 Turn the **Mode** knob (W4) or press the **Mode** rocker switch (W5, W7, W9) to locate the **INDX SEL** option.
- 3 Press  to enter the Index Selection menu.

The display changes to show the last index that was selected and stored after the Index Selection menu was entered.

- 4 Turn the **Mode** knob (W4) or press the **Mode** rocker switch (W5, W7, W9) to locate the desired key index.
  - 5 Choose one of the following:
    - To save an index key, press . The radio will save the index and return to normal operation,
    - To abort from the Index Selection menu, press  or the **PTT** button. (Pressing the **PTT** button allows the radio to transmit.)
-

## Troubleshooting

The following are suggestions to assist you in troubleshooting possible operating problems.

	<b>CAUTION</b>
<p>The cables that connect to the rear of the radio could have live voltage on some of their pins. Do not remove or reconnect these cables. Only a qualified radio technician should perform this task. Service performed by unauthorized personnel may cause the radio to transmit an emergency alarm even if the unit is turned off.</p>	

If your radio is locked up or the display shows FL 01/90 (W4, W5, W7) or FAIL 01/90 (W9), turn the radio off and then back on. If this does not correct the condition, take the radio to a qualified radio technician for service.

If radio operation is intermittent, check with other persons using the system for similar problems before taking the radio in for service. Similar problems indicate a system malfunction rather than a radio failure.

If symptoms persist or, if your unit exhibits other problems, contact a qualified radio technician.



# Glossary

---

<b>ACK</b>	Acknowledgment of communication.
<b>Channel</b>	A group of characteristics, such as transmit/receive frequency pairs, radio parameters, and encryption encoding.
<b>Coded Squelch</b>	Tone Private-Line™ or Digital Private-Line. Used on conventional channels to make sure you hear only the communication meant for you.
<b>Control Channel</b>	In a trunking system, one of the channels that is used to provide a continuous, two-way/data communications path between the central controller and all radios on the system.
<b>Conventional</b>	Typically refers to radio-to-radio communications, sometimes through a repeater. You share a frequency, or frequencies, with other users without the aid of a central controller to assign communication channels. Therefore, you should monitor each channel before transmitting to avoid interfering with another user who may be transmitting.
<b>Cursor</b>	A visual tracking marker (a blinking line) that indicates a location on the display.
<b>Digital Private-Line (DPL) Coded Squelch</b>	A continuous, sub-audible data signal, transmitted with the carrier.
<b>Dispatcher</b>	An individual who has radio system management duties.
<b>Failsoft</b>	A back-up system allowing you to communicate in a non-trunked, conventional mode should the trunked system fail.
<b>FCC</b>	Federal Communications Commission.

<b>Hang Up</b>	Disconnect.
<b>Home Display</b>	The first display information after the radio completes its self test.
<b>LCD</b>	Liquid-Crystal Display.
<b>Mode</b>	A programmed combination of operating parameters; for example, a channel or talkgroup.
<b>Mode-Slaving</b>	Radio programmed to automatically give the proper operation for a given mode you have selected.
<b>Monitoring (Conventional Operation)</b>	Press a programmed monitor button to listen to another user active on the channel. This way, you may be prevented from talking over someone else's conversation.
<b>Page</b>	A one-way alert, with audio and/or display messages.
<b>Push-To-Talk (PTT) button</b>	The PTT button engages the transmitter and puts the radio in transmit (send) operation when pressed. Press this button to transmit; release it to receive.
<b>Repeater</b>	A conventional radio feature, in which you talk through a receive/transmit facility (repeater) that re-transmits received signals in order to improve communications range and coverage.
<b>RF</b>	Radio Frequency. A part of the general frequency spectrum between the audio and infrared light regions (about 10 kHz to 10,000,000 MHz).
<b>RSSI</b>	Received <b>S</b> ignal <b>S</b> trength <b>I</b> ndicator.

<b>Squelch</b>	The muting of audio circuits when received signal levels fall below a pre-determined threshold. With carrier squelch, you hear all channel activity which exceeds the radio's preset squelch level.
<b>Standby</b>	An operating condition whereby the radio's speaker is muted but still continues to receive data.
<b>Talkgroup</b>	An organization (or group) of radio users who communicate with each other, using the same communication path.
<b>Tone Private-Line (PL) Coded Squelch</b>	A continuous sub-audible tone transmitted with the carrier.
<b>Trunking</b>	The automatic sharing of communications paths between a large number of users (see Conventional). Allows radio users to share a smaller number of frequencies because a repeater, or communications path, is assigned to a talkgroup for the length of a conversation.
<b>Zone</b>	A grouping of channels or talkgroups.

## Notes

## Patent Disclosure

This product is covered by one or more of the following United States patents:

4,512,035 4,551,856 4,653,117 4,816,774 4,829,594 4,837,853 4,864,252  
4,885,550 4,914,321 4,918,403 4,959,617 4,975,650 4,994,768 5,006,730  
5,021,754 5,079,526

## Commercial Warranty (Standard)

Motorola radio communications products are warranted to be free from defects in material and workmanship for a period of ONE (1) YEAR, (except for crystals and channel elements which are warranted for a period of ten [10] years) from the date of shipment. Parts, including crystals and channel elements, will be replaced free of charge for the full warranty period, but the labor to replace defective parts will only be provided for one-hundred-twenty (120) days from the date of shipment. Thereafter, purchaser must pay for the labor involved in repairing the product or replacing the parts at the prevailing rates together with any transportation charges to or from the place where warranty service is provided. This express warranty is extended by Motorola Communications and Electronics, Inc., 1301 E. Algonquin Road, Schaumburg, Illinois 60196, to the original purchaser only, and only to those purchasing for purpose of leasing or solely for commercial, industrial, or governmental use.

THIS WARRANTY IS GIVEN IN LIEU OF ALL OTHER WARRANTIES EXPRESS OR IMPLIED WHICH ARE SPECIFICALLY EXCLUDED, INCLUDING WARRANTIES OR MERCHANTABILITY OR FITNESS FOR A PARTICULAR PURPOSE. IN NO EVENT SHALL MOTOROLA BE LIABLE FOR INCIDENTAL OR CONSEQUENTIAL DAMAGES TO THE FULL EXTENT SUCH MAY BE DISCLAIMED BY LAW.

In the event of a defect, malfunction, or failure to conform to specifications established by seller, or if appropriate, to specifications accepted by seller in writing, during the period shown, Motorola, at its option, will either repair or replace the product or refund the purchase price thereof, and such action on the part of Motorola shall be the full extent of Motorola's liability hereunder.

This warranty is void if:

- a. the product is used in other than its normal and customary manner;
- b. the product has been subject to misuse, accident, neglect, or damage;
- c. unauthorized alterations or repairs have been made, or unapproved parts used in the equipment.

This warranty extends only to individual products, batteries are excluded, but carry their own separate limited warranty. Because each radio system is unique, Motorola disclaims liability for range, coverage, or operation of the system as a whole under this warranty except by a separate written agreement signed by an officer of Motorola.

Non-Motorola manufactured products are excluded from this warranty, but subject to the warranty provided by their manufacturers, a copy of which will be supplied to you on specific written request.

In order to obtain performance of this warranty, purchaser must contact a Motorola salesperson or Motorola at the address shown above, Attention Quality Assurance Department.

This warranty applies only within the United States.

# Index

---

## Symbols

800 MHz frequencies .....2

## A

add scan list channel .....34

adjust

display brightness .....6

squelch level .....18

volume .....6

alarms

activate non-permanent .....36

activate permanent .....37

change selected .....38

horn and lights .....36

initiate

emergency .....21

emergency call and alarm ....23

silent emergency .....24

non-permanent horn and lights

activation .....36

non-rearmable external .....39

optional external .....36

permanent horn and lights

activation .....37

rearmable external .....39

receiving call when turned on ..39

alert tones .....8

analog

mode .....3

trunking system considerations 95

answer

Call Alert page .....53

Enhanced Private Conversation

call .....66, 75

phone call .....42

ASTRO mode .....3

automatic scanning .....26

autoscan .....26

## B

basic operation .....11

box, hang up (HUB) .....36

buffered overdial .....45

button

Del .....31

Dim .....39

PTT .....30

Zone down .....34

Zone up .....34

## C

call

answer phone .....42

conventional talkgroup .....62

emergency .....20

Enhanced Private Conversation .  
67, .....76

initiate

emergency .....22

Enhanced Private

Conversation .....67, 76

from phone list .....42

phone number not in list .....44

receiving when alarms

turned on .....39

Call Alert page

answering .....53

description .....50

placing .....51

selecting unit to call .....51

sending .....51

calls, status .....58

change

mode .....12

mode in current zone .....13

mode not in current zone .....13

mode priorities .....33

selected alarms .....38

zone .....12

channels, conventional .....7

considerations

analog trunking systems .....95

digital trunking systems .....95

trunked systems .....95

control head  
 operation .....5  
 status display .....8  
 conventional  
 channel .....7  
 mode .....15  
 scan list .....26  
 selecting talkgroup .....62  
 talkaround .....64  
 talkgroup calls .....62  
 conventional mode, monitoring  
 activity .....17  
 current zone  
 change mode .....13  
 select mode .....13

**D**

Del button .....31  
 delete  
 nuisance mode .....31  
 scan list channel .....35  
 digital trunking system  
 considerations .....95  
 Dim (dimmer) button .....39  
 direct-entry keyboard, send  
 status .....60  
 display, brightness adjustment .....6  
 dynamic regrouping  
 receiving an ID assignment ....82  
 requesting .....83

**E**

edit name in list .....47, 55, 79  
 embedded signaling .....2  
 emergencies, special  
 considerations .....25  
 emergency call  
 initiating .....22  
 trunking .....20  
 emergency call and alarm  
 description .....20  
 initiating .....23  
 encryption key

index selection .....99  
 selecting .....97  
 Enhanced Private Conversation  
 answer a call .....66, 75  
 description .....74  
 initiate call .....67, 76  
 select unit to call .....67, 76  
 entering keypad characters .....49  
 external alarms .....36  
 activate non-permanent horn and  
 lights .....36  
 activate permanent horn and  
 lights .....37  
 non-rearmable .....39  
 rearmable .....39

**F**

failsoft .....81  
 FLASHport technology .....3  
 frequency ranges  
 800 MHz .....2

**G**

glossary .....101

**H**

hang time .....27  
 hang up box (HUB) .....36  
 Home  
 mode, selecting .....14  
 horn and lights alarms .....36  
 HUB (hang up box) .....36

**I**

identification, radio .....4  
 indicator  
 N PRI (non-priority) .....27  
 Phone .....44  
 PRI (priority) .....27  
 scan .....27  
 initiate  
 emergency alarm .....21



- 
- emergency call and alarm .....23
  - Enhanced Private Conversation
    - call .....67, 76
    - phone call from list .....42
    - silent emergency alarm .....24
    - trunked announcement .....91
  - interconnect, unlimited telephone 44
  - introduction to radios ..... 1
  
  - K**
  - key, encryption
    - index selection .....99
    - selecting .....97
  - keypad
    - character selection sequence ..49
    - entering characters .....49
  - knob
    - Mode .....4, 29
    - Volume .....4
  
  - L**
  - list
    - edit name .....47
    - editing a name .....55, 79
    - phone, place call .....42
    - scan .....26
    - store phone number .....46
    - storing unit ID number .....54, 78
    - telephone interconnect .....41
  - live overdial .....45
  - lock on a site, SmartZone .....87
  - loss indication, secure operation .96
  
  - M**
  - Mode
    - knob .....4, 29
    - rocker button .....29
  - mode
    - analog .....3
    - ASTRO .....3
    - changing .....13
    - changing outside current zone 13
  - Mode
    - knob .....29
    - rocker button .....29
    - priorities, changing .....33
    - selecting .....13
    - selecting Home .....14
    - selecting outside current zone 13
    - selection .....12
    - slaving .....7
    - transmitting (conventional) .....15
    - transmitting (trunked) .....15
    - trunked .....7
  - monitoring
    - conventional mode activity ..... 17
  
  - N**
  - N PRI (non-priority) indicator ..... 27
  - non-priority scanning .....26
  - non-rearmable external alarms ...39
  - non-ruthless preemption .....90
  - non-talkback scan .....30
  - nuisance mode
    - deleting .....31
    - restoring .....32
  
  - O**
  - operation
    - basic .....11
    - control head .....5
    - scan .....26
    - secure .....93
    - SmartZone site-button .....86
    - trunking .....73
  - operator-selectable scan .....26
  - out-of-range indication .....89
  - overdial
    - buffered .....45
    - live .....45
  
  - P**
  - patent disclosure .....105
  - Phone indicator .....44

phone numbers, preprogrammed	41	operator-selectable	26
place phone call from list	42	priority	26
placing Call Alert page	51	talkback	30
power level selection	16	transmit while on	30
powering on radio	5	turning on	27
preemption		scan list	
non-ruthless	90	add a channel	34
ruthless	90	conventional	26
preprogrammed phone numbers	41	delete a channel	35
PRI (priority) indicator	27	modes	26
priority scanning	26	programming	34
private message		restore mode priorities	33
receive	94	talkgroup scan	26
transmit	94	trunked priority	26
programming scan list	34	viewing	29
PTT button	30	secure operation	93
PTT-ID		select	
(Push-to-Talk identification)	40	Call Alert page unit	51
Push-to-Talk identification		conventional talkgroup	62
(PTT-ID)	40	encryption key	97
		encryption key index	99
		Home mode	14
<b>R</b>		mode	12
radio identification	4	mode in current zone	13
rearmable external alarms	39	mode not in current zone	13
receive		power level	16
call with alarms turned on	39	volume level	6
private message	94	zone	12
requesting a dynamic regrouping	83	selected-disabled units	83
restore		selected-enabled units	83
mode priorities	33	send	
nuisance mode	32	Call Alert page	51
rocker button		status call	58
Mode	29	site trunking	
Vol (volume)	39	SmartZone	88
ruthless preemption	90	site-button operation, SmartZone	86
		slaved programming	7
		slaving, mode	7
		smart PTT	61
		SmartZone	
		description	85
		lock on a site	87
		site trunking	88
<b>S</b>			
scan			
autoscan	26		
indicator	27		
non-priority	26		
non-talkback	30		
operation	26		

- 
- site-button operation .....86
  - squelch, adjusting level ..... 18
  - status calls
    - description .....58
    - sending .....58
  - status display, control head .....8
  - store phone number in list .....46
- T**
- talk direct (mobile-to-mobile) .....64
  - talkback scan .....30
  - talkgroup scan list .....26
  - telephone interconnect list .....41
  - time-out timer .....40
  - tones, alert .....8
  - transmit
    - conventional modes ..... 15
    - private message .....94
    - trunked modes ..... 15
    - with scan on .....30
  - transmitting ..... 15
  - troubleshooting .....100
  - trunked
    - announcement
      - capability .....90
      - initiate .....91
    - Call Alert page .....50
    - mode .....7, 15
    - priority scan list .....26
    - system considerations .....95
  - trunking
    - answer phone call .....42
    - emergency call .....20
    - Enhanced Private
      - Conversation .....74
    - failsoft .....81
    - initiating emergency call .....22
    - operation .....73
    - status calls .....58
    - telephone interconnect list .....41
    - unlimited telephone
      - interconnect .....44
  - turn on
    - radio ..... 5
    - scan ..... 27
- U**
- unit ID number, store in list ... 54, 78
  - units
    - select-disabled .....83
    - select-enabled .....83
    - troubleshooting ..... 100
  - unlimited telephone interconnect 44
- V**
- viewing scan list .....29
  - Vol (volume) rocker button ..... 39
  - Volume knob ..... 4
  - volume, adjusting ..... 6
- W**
- W4 Control Head Foldout ..... i
  - W5 Control Head Foldout ..... i
  - W7 Control Head Foldout ..... 113
  - W9 Control Head Foldout ..... 113
  - warranty, standard commercial 105
- Z**
- Zone down button ..... 34
  - zone selection ..... 12
  - Zone up button ..... 34

## Notes





# ASTRO® XTL™ 5000 Digital Mobile Radio with W7 Control Head

## Quick Reference Card

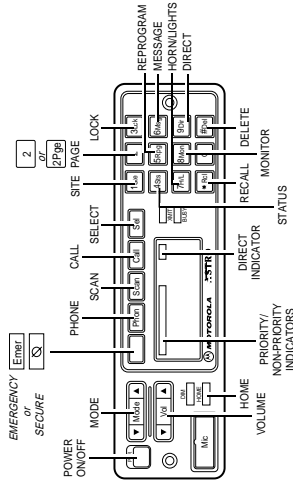

### BASIC OPERATION

#### Turning the Radio On and Off

Press the **PWR** button once.

#### Setting the Volume and Squelch

- Hold the **Vol** rocker switch down to increase or decrease volume as desired, then release. The display shows volume levels from **0** to **15**.
- On conventional modes with Private-Line or Digital Private-Line, press **Mon** or remove the microphone from the hang-up clip to defeat the coded squelch.
- Press **Mon** again, or replace the microphone on the hang-up clip to return to coded-squelch operation.
- To adjust squelch level, hold **Mon** until a tone sounds.
- Press the **Mode** rocker switch to select squelch level.
- Press **HOME**.

#### Changing Modes

Press the **Mode** rocker switch to select the desired mode

**OR**

Press **HOME** to access the preprogrammed Home mode.

#### Transmitting

- Press and hold the microphone **PTT** button.
- When the transmit light comes on solid and no alert tones sound (or a talk-permit tone or ID sidetone sounds), speak into the microphone in a normal voice.
- State your FCC call sign at the beginning of each transmission.

### Transmitting (Conventional Modes)

- Press **Dir** (Direct). The **Dir** indicator lights.
- Press **Dir** again to return to repeater operation.

#### Activating Scan

- Press **Scan** to start a scan. If no activity exists, the display shows your selected mode. When a scanned channel or talkgroup becomes active, the display shows the active mode name. The **PRI** and **NPRI** indicators show priority.
- Press **Scan** again to stop scanning.

#### Programming a Scan List

- Hold **Scan** until a tone sounds and the scan indicator blinks.
- Press the **Mode** rocker switch to select the mode you want to program.

**OR**

Press the **Rcl** button to scroll through the modes currently in the scan list.

- Press the **Sel** button as indicated in the table below to add or remove the displayed mode from the scan list.
- Repeat the previous steps to continue editing the list.
- Press **HOME** or **Scan** to exit.

Press Sel	Mode	Indicator
One time	Non-Priority	<b>NPRI</b> lit
Two times	Second Priority	<b>PRI</b> lit
Three times	First Priority	<b>PRI</b> blinks
Four times	Delete from List	No indicator

## Selecting Scan Mode Priority

- 1 Press the **Sel** button as indicated in the table above to designate up to two modes as priorities.
- 2 Press **HOME** or **Scan** to end scan list selection.

## Sending an Emergency Alarm or Call

Press the emergency actuator (**Emer** button, footswitch, hidden pushbutton) to begin an emergency transmission.

For conventional modes, a silent or non-silent emergency alarm data transmission is sent.

For trunked modes, emergency call (priority access to a voice channel), silent or non-silent emergency alarm, or emergency alarm and call is entered.

Depending on your radio's programming, one of the emergency sequences described in the table below occur.

Alarm Type	Indications/Actions
Call (Trunked Modes only)	A tone sounds and the display flashes <b>EMERGENCY</b> . Press the <b>PTT</b> button and talk. After completing the call, press and hold the emergency actuator until a tone sounds to return to normal operation.
Alarm and Call	After the display shows <b>ACK RCVD</b> (see Non-Silent Alarm above), the radio has priority voice-channel access. Press the <b>PTT</b> button and talk. After completing the call, press and hold the emergency actuator until a tone sounds to return to normal operation.

## Sending a Status Transmission

1	Press <b>Sts</b> . The display shows the last acknowledged status or first status name.
2	Press the <b>Mode</b> rocker switch to select other statuses.
3	Press <b>Sel</b> to send the transmission. The display flashes the selected status name until the dispatcher acknowledges, at which time alert tones sound and the display shows <b>ACK RCVD</b> . The radio then returns to normal operation.

## Sending a Direct-Entry Keyboard Status Transmission

Press the appropriate **Sts #** button that you wish to send. The associated indicator blinks until an acknowledgment is received, then it lights steadily.

## Sending a Direct-Entry Enhanced Private Conversation Call

- 1 Press **Sel** or the **PTT** button. A single tone sounds and the display changes to **PLS WAIT**, followed by telephone-type ringing if the receiving unit is in service.
- 2 If the receiving unit answers, press the **PTT** button to identify yourself and proceed with your call.  
**OR**  
If the called unit does not respond, press **Sel** or the **PTT** button again to leave a Call Alert page message and your ID.  
A single tone followed by four tones sounds if the called unit acknowledges the page.

## Initiating a Call Alert Page

- 1 Press the **Page** button.
- 2 Follow the instructions for initiating a Private Conversation to select a unit ID.
- 3 Press **Sel** or the **PTT** button to send a Call Alert page to the displayed ID.  
**OR**  
To send a Call Alert page following an Enhanced Private Conversation attempt, follow the instructions for sending a direct-entry Enhanced Private Conversation call.



## Answering a Call Alert Page

Four tones sound and **PRG** **RDV** flashes on the display. The tone and display repeat every five seconds.

- 1 Press the **PTT** button.

**OR**

Initiate an Enhanced Private Conversation call to the caller.

## Selecting a Zone/Mode (Optional)

- 1 Press the Zone Up ▲ button or Zone Down ▼ button to scroll to the desired zone.
- 2 Press the **Mode** rocker switch to select the mode.

## Selecting a Home Zone/Home Mode

Press the **HOME** button.

## Requesting Dynamic Regrouping

Press **Rpg**. A central acknowledgement tone sounds and the display shows **RPGM** **ROST** while the request is being processed. When the dispatcher acknowledges, four additional tones sound, the display shows **RCK** **ROVD**, and your radio returns to normal operation.

## Automatic Multiple Site Selection (AMSS)

*View the Current Site*

Press **Ste** momentarily. If the radio is scanning for a new site, the display shows **SCANNING**.

## Initiating a Site Scan

Press and hold **Ste** until a tone sounds and the display shows **SCANNING**.

## Locking on a Site

- 1 Press **Lck** to lock the radio onto the current site.
- 2 To view its condition (locked or unlocked), press **Lck** momentarily. The display shows **LOCKED** or **UNLOCKED**.

**OR**

To toggle to the opposite condition, press and hold **Lck** until a beep sounds and the display changes to the other condition. The radio then returns to normal operation.

## Selecting Secure Mode

Press and release the **Sec** button. The **Sec** indicator lights up.

## Selecting an Encryption Key

- 1 Press and hold the **Key** button until a tone sounds.
- 2 Press the **Mode** rocker switch to scroll to **KEY SEL**.
- 3 Press **Sel** to enter the Key Selection Menu.
- 4 Press the **Mode** rocker switch to select the desired key.
- 5 Press **Sel** to select the key.
- 6 Press **HOME** or the **PTT** button to quit.

## Selecting a Key Index

- 1 Press and hold the **Key** button until a tone sounds.
- 2 Press the **Mode** rocker switch to scroll to **INDEX SEL**.
- 3 Press **Sel** to enter the Index Selection Menu.
- 4 Press the **Mode** rocker switch to select the desired index.
- 5 Press **Sel** to select the index.
- 6 Press **HOME** or the **PTT** button to quit.

## Erasing an Encryption Key

- 1 Press and hold the **Key** button until a tone sounds.
- 2 Press the **Mode** rocker switch to scroll to **ERASE KEY**.
- 3 Press **Sel** to enter the Key Erase Menu.
- 4 Press the **Mode** rocker switch to select the desired index.
- 5 Press **Sel** to select the index.
- 6 Press **HOME** or the **PTT** button to quit.

## DISPLAY AND LIGHT INDICATORS

Display/Light	Meaning
BUSY light on	The display shows a conventional mode with activity on it, or selected trunked system is currently busy. Wait for callback.
XMIT light on	Indicates you are transmitting.
Dir indicator lit	Radio is in direct (mobile-to-mobile) operation.
PRI, NPRI indicators lit	The display shows a mode in the scan list with the indicated priority level.
P displayed	Telephone dialing pause. Press <b>SEL</b> to continue the dialing.
NO ACK displayed	Unit being called with the Enhanced Private Conversation or Call Alert Page feature is not in service, or emergency alarm or status/message transmission is not acknowledged by dispatcher.
NO ANSWER displayed	Unit being called with Enhanced Private Conversation or Call Alert Page does not respond, but is operational.
EMERGENCY displayed	Radio is in emergency alarm or call state.
NO EMERG displayed	A mode incapable of emergency transmission has been selected.
OUT RING displayed	Radio is out of range of the trunking system.

## ALERT TONES

Type of Tone	Name	Explanation
1 Low-Pitched Tone	Invalid Key Alert	Feature button pressed is not valid in selected mode, or a Call Alert or emergency alarm was not acknowledged.
1 High-Pitched Tone	Central Acknowledge or Valid Key	Central controller has received request for Call Alert or emergency alarm transmission. You pressed a valid key.
4 High-Pitched Tones	Dispatcher or Mobile Unit Acknowledge	Dispatcher is acknowledging your emergency transmission. Mobile unit has received your Call Alert.
5 High-Pitched Tones		The above two acknowledge tones, heard in tandem.
2 High-Pitched Tones	Private Conversation	You have an incoming call. Press <b>CALL</b> , then the <b>PTT</b> button, then talk.
4 High-Pitched Tones every 6 seconds	Call Alert Page	Call Alert page has been received.
3 Short High-Tones (after requesting a busy channel) (upon pressing the <b>PTT</b> button)	Automatic Call Back or Talk Permit	Channel is available for previously requested transmission. System is accepting your transmission.

## ALERT TONES (Continued)

Type of Tone	Name	Explanation
Low-Pitched Tone (upon pressing the <b>PTT</b> button during Transmit) (Operation Error)	Talk Prohibit/ Out-of-Range, or Time-Out Timer, or Illegal Mode	Out of trunked radio system range or system is out of service. Present transmission will soon be disabled. You have entered a mode where normal system traffic will be missed, or you attempted something that is not allowed. (See examples below.)
High-Pitched Tone every 10 seconds in unmuted receive condition	Failsafe	System central controller failure. The radio reverts from trunked operation to operation similar to a conventional repeater. Others may share the channel.

**Examples:** Not exiting phone mode after a call (radio cannot receive fleet or subfleet calls), transmitting in receive-only conventional mode, trying to select a dynamic mode when no dynamic ID assignment has been made.

# ASTRO® XTL™ 5000 Digital Mobile Radio with W9 Control Head

## Quick Reference Card

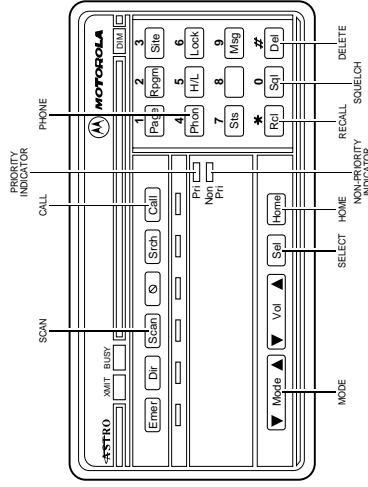

### BASIC OPERATION

#### Turning the Radio On and Off

Slide the power switch on the bottom of the control unit to the left.

#### Setting the Volume and Squelch

- 1 Hold the **Vol** rocker switch down to increase or decrease volume as desired, then release. The display shows volume levels from **0** to **15**.
- 2 On conventional modes with Private-Line or Digital Private-Line, press **Sq1** or remove the microphone from the hang-up clip to defeat the coded squelch.
- 3 Press **Sq1** again to return to coded-squelch operation.
- 4 To adjust squelch level, hold **Sq1** until a tone sounds.
- 5 Press the **Mode** rocker switch to select squelch level.
- 6 Press **Home**.

#### Changing Modes

Press the **Mode** rocker switch to scroll to the desired mode

OR

Press **Home** to access the preprogrammed Home mode.

#### Transmitting

- 1 Press and hold the microphone **PTT** button.
- 2 When the transmit light comes on solid and no alert tones sound (or a talk-permit tone or ID sidetone sounds), speak into the microphone in a normal voice.
- 3 State your FCC call sign at the beginning of each transmission.

### Transmitting (Conventional Modes)

- 1 Press **Dir** (Direct). The **Dir** indicator lights.
- 2 Press **Dir** again to return to repeater operation.

### TELEPHONE OPERATION

#### Making a Phone Call

Press **Phon** to select the phone function. The display shows the last phone number dialed or a series of dashes.

#### Dialling the Number in the Display

- 1 Press **Sel** or the **PTT** button, and wait for dial tone.
- 2 Press **Sel** or the **PTT** button again to dial the number in the display.

#### Dialling a Number from the Pre-Stored List

- 1 Press the **Mode** rocker switch to scroll to the number or name you want to call.
- 2 Press **Sel** or the **PTT** button, and wait for dial tone.
- 3 Press **Sel** or the **PTT** button again to dial the number in the display.

#### Dialling or Direct Dialling a New Number

- 1 Using the keypad, enter the telephone number.
- 2 Press **Sel** or the **PTT** button, and wait for dial tone.
- 3 Press **Sel** or the **PTT** button again to dial the number in the display.

### Answering a Phone Call in Trunked Modes

When a call is received, ringing tones are heard from the speaker, and the display shows **PHONE**.

- 1 Press **PHON** and begin your conversation.
- 2 Press **Home** to hang up.

### Making a Call (Trunked Modes Only)

A tone sounds and the display alternates between **EMERGENCY** and the zone/channel.

- 1 Press the **PTT** button and talk.
- 2 After completing the call, press and hold the emergency actuator until a tone sounds to return to normal operation.

### Alarm and Call

After the display shows **RCK RCVU**, your radio has priority voice-channel access.

- 1 Press the **PTT** button and talk.
- 2 After completing the call, press and hold the emergency actuator until a tone sounds to return to normal operation.

### Sending a Status Transmission

- 1 Press **Sts**. The display shows the last acknowledged status or first status name.
- 2 Press the **Mode** rocker switch or use the keypad to select other statuses.

- 3 Press **Se1** or the **PTT** button to send the transmission. The display flashes the **FLERSE WRTT** until the dispatcher acknowledges, at which time alert tones sound and the display shows **RCK RCVU**. The radio then returns to normal operation.

### Sending a Direct-Entry Keyboard Status Transmission

Press the appropriate **Sts #** button that you wish to send. The associated indicator blinks until an acknowledgment is received, then it lights steadily.

### Initiating an Enhanced Private Conversation Call

- 1 Press **Sel** or the **PTT** button. A single tone sounds and the display changes to **FLERSE WRTT**, followed by telephone-type ringing if the receiving unit is in service.
- 2 If the receiving unit answers, press the **PTT** button to identify yourself and proceed with your call.

**OR**

If the called unit does not respond, press **Sel** or the **PTT** button again to leave a Call Alert page message and your ID.  
A single tone followed by four tones sounds if the called unit acknowledges the page.

### Initiating a Private Conversation II

- 1 Press the **PTT** button to initiate a Private Conversation I or II call.
- 2 Pause for a second, then begin the conversation.
- 3 Press **Home** or **Call** to hang up.

### Initiating a Call Alert Page

- 1 Press the **Page** button.
- 2 Follow the instructions for initiating an Enhanced Private Conversation to select a unit ID.

- 3 Press **Sel** or the **PTT** button to send a Call Alert page to the ID in the display.

**OR**

To send a Call Alert page following an Enhanced Private Conversation attempt, follow the instructions for sending an Enhanced Private Conversation call.

### Answering a Call Alert Page

Four tones sound and **PAGE RCVU** flashes on the display.

- 1 Press either the microphone **PTT** button or the **Call** button to clear the Call Alert state.

### Answering a Private Conversation Call

Two tones sound and **CALL RCVU** flashes on the display.

- 1 Press the **Call** button.
- 2 Press the microphone **PTT** button, and speak into the microphone.
- 3 Press **Home** or **Call** to hang up.

## Requesting Dynamic Regrouping

Press **Rpgm**. A central acknowledgement tone sounds and the display shows **RPGM REQUEST** while the request is being processed.  
When the dispatcher acknowledges, four additional tones sound, the display shows **ACK RCVD**, and your radio returns to normal operation.

## Automatic Multiple Site Selection (AMSS)

### Viewing the Current Site

Press **Site** momentarily. If the radio is scanning for a new site, the display shows **SCANNING**.

### Initiating a Site Scan

Press and hold **Site** until a tone sounds and the display shows **SCANNING**.

### Locking on a Site

- 1 Press **Lock** to lock the radio onto the current site.
- 2 To view its condition (locked or unlocked), press **Lock** momentarily. The display shows **SITE LOCKED** or **SITE UNLOCKD**.

### OR

To toggle to the opposite condition, press and hold **Lock** until a tone sounds and the display changes to the other condition.  
The radio then returns to normal operation.

## Selecting Secure Mode

Press and release the **SEL** button. The **SEL** indicator lights up.

### Selecting an Encryption Key

- 1 Press and hold the **SEL** button until a tone sounds.
- 2 Press the **Mode** rocker switch to scroll to **KEY SEL**.
- 3 Press **Sel** to enter the Key Selection Menu.
- 4 Press the **Mode** rocker switch to select the desired key.
- 5 Press **Sel** to select the key.
- 6 Press **HOME** or the **PTT** button to quit.

### Selecting a Key Index

- 1 Press and hold the **SEL** button until a tone sounds.
- 2 Press the **Mode** rocker switch to scroll to **INDEX SEL**.
- 3 Press **Sel** to enter the Index Selection Menu.
- 4 Press the **Mode** rocker switch to select the desired index.
- 5 Press **Sel** to select the index.
- 6 Press **HOME** or the **PTT** button to quit.

## Erasing an Encryption Key (Single-Key Option Only)

- 1 Press and hold the **SEL** button until a tone sounds. The display changes to **ERASE KY**.
- 2 Press **Sel** to erase the key.
- 3 Press **HOME** or the **PTT** button to quit.

## Erasing an Encryption Key

- 1 Press and hold the **SEL** button until a tone sounds.
- 2 Press the **Mode** rocker switch to scroll to **ERASE KY**.
- 3 Press **Sel** to enter the Key Erase Menu.
- 4 Press the **Mode** rocker switch to select the desired index.
- 5 Press **Sel** to select the index.
- 6 Press **HOME** or the **PTT** button to quit.

## DISPLAY AND LIGHT INDICATORS

<i>Message</i>	<i>Meaning</i>
<b>BUSY</b> light on	Displayed conventional mode has activity on it, or selected trunked system is currently busy. Wait for callback.
<b>XMIT</b> light on	Indicates you are transmitting.
<b>Pri</b> indicator blinks	Mode displayed is first priority.
<b>Pri</b> indicator lit	Mode displayed is second priority.
Non <b>Pri</b> lit	Mode displayed is non-priority.
<b>P</b> displayed	Telephone dialing pause. Press <b>SEL</b> to continue the dialing.
<b>NO ACK</b> displayed	Unit being called with the Enhanced Private Conversation or Call Alert Page feature is not in service, or emergency alarm or status/message transmission is not acknowledged by dispatcher.
<b>LIST FULL</b> displayed	Scan list full. Delete a mode before adding another.
<b>PHON BUSY</b> displayed	Trunked phone interconnect is busy.
<b>NO ANSWER</b> displayed	Unit being called with Enhanced Private Conversation or Call Alert Page does not respond, but is operational.
<b>EMERGENCY</b> displayed	Radio is in emergency alarm or call state.
<b>NO EMERGENCY</b> displayed	A mode incapable of emergency transmission has been selected.
<b>OUT OF RANGE</b> displayed	Radio is out of range of the trunking system.

## ALERT TONES

<i>Type of Tone</i>	<i>Name</i>	<i>Explanation</i>
1 Low-Pitched Tone	Invalid Key Alert	Feature button pressed is not valid in selected mode, or a Call emergency alarm was not acknowledged.
1 High-Pitched Tone	Central Acknowledge or Valid Key	Central controller has received request for Call Alert, emergency alarm, reprogram request, or status/message transmission. You pressed a valid key.
4 High-Pitched Tones	Dispatcher or Mobile Unit Acknowledge	Dispatcher is acknowledging your emergency transmission. Mobile unit has received your Call Alert.
5 High-Pitched Tones		The above two acknowledge tones, heard in tandem.
2 High-Pitched Tones	Private Conversation	You have an incoming call. Press <b>Call</b> , then the <b>PTT</b> button and talk.
4 High-Pitched Tones every 6 seconds	Call Alert Page	Call Alert page has been received.
Phone-Type Busy Tone (when pressing the <b>PTT</b> button)	System Busy	All system radio channels in use. Release the <b>PTT</b> button, and wait for callback.





Motorola, Inc.  
8000 West Sunrise Boulevard  
Ft. Lauderdale, FL 33322

MOTOROLA, the Stylized M Logo, and ASTRO are registered  
in the U.S. Patent and Trademark Office. All other product or  
service names are the property of their respective owners.  
© Motorola, Inc. 2003.  
All rights reserved. Printed in U.S.A.



**68P81096C68-O**