

4.5 Motorola Branded SB9600 Siren Connection to APX 8500

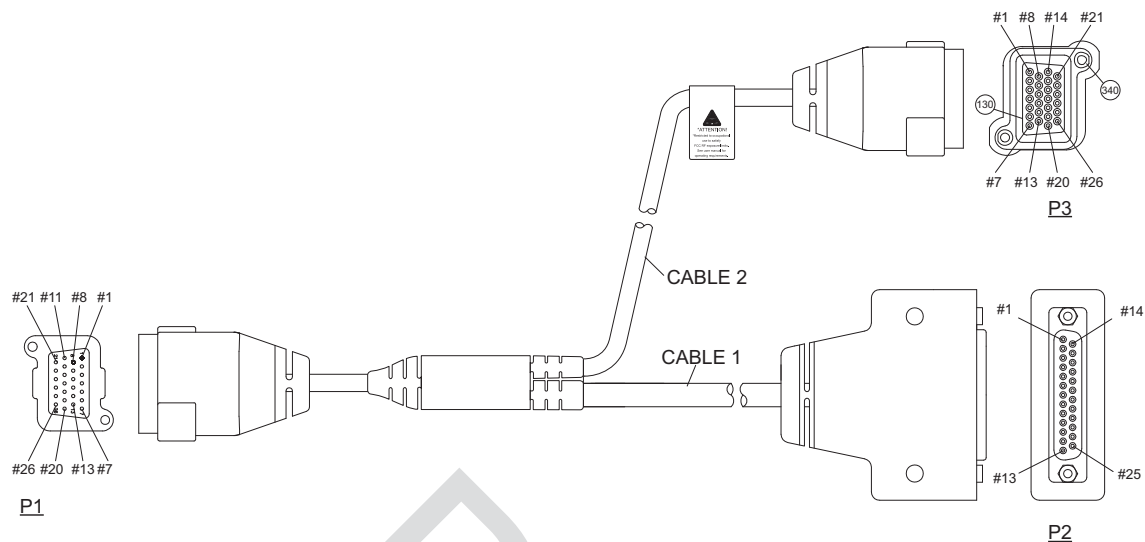

Figure 4-10. J600 Accessory Connector Y-Cable KT000247A01

CONNECTION

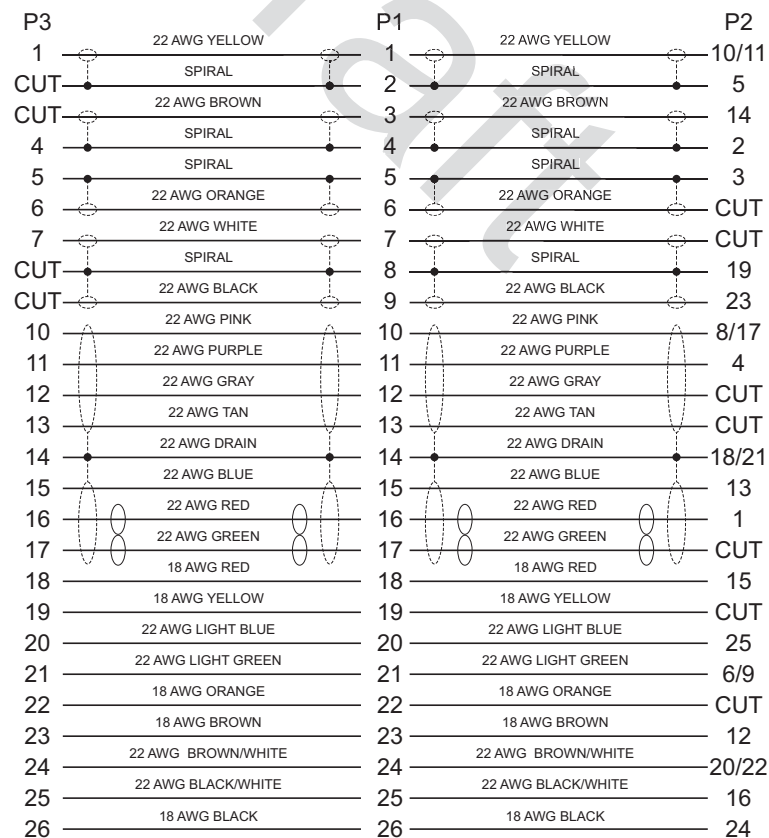

Figure 4-11. Pinout for cable KT000247A01

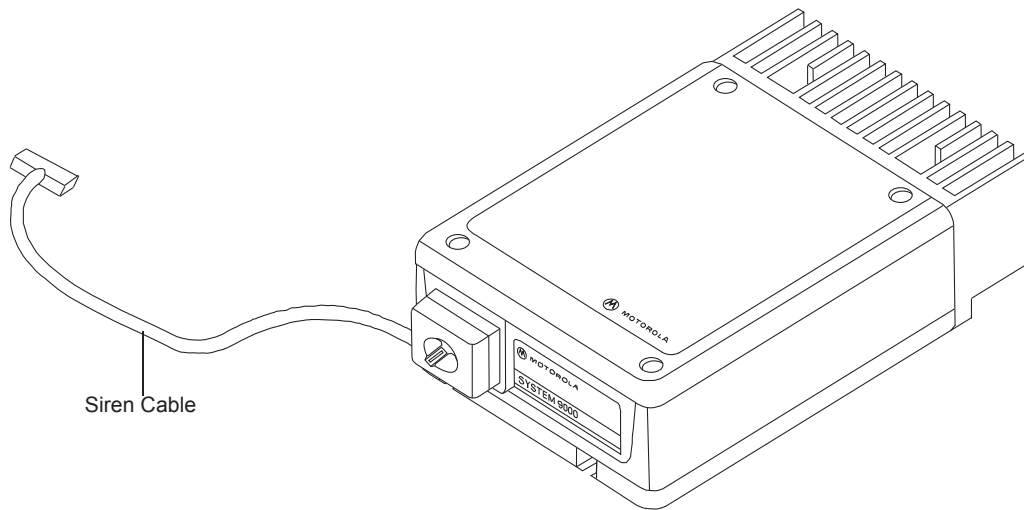

Figure 4-12. Interfacing the Y-cable to the Motorola Branded SB9600 Siren and External Accessories

The Y-cable KT000247A01 is primarily designed to allow for simultaneous operation of the Motorola Branded SB9600 siren and still retain duplicate access to all the MAP (J2) connector pins located on the APX 8500 remote TIB. Use of emergency accessories, speakers, programming cables, VIPs, etc are possible via the P3 connector of Y-cable KT000247A01. The 25pin connector P2 does not contain every signal from the legacy DB25 port, called J600 on the APX 7500. Therefore, some legacy functionality (i.e. A+) is reduced with the APX 8500 remote mount configuration compared to the APX 7500 remote mount configuration.

NOTE: Only USB 1.5 meter data cable HKN6163_ is approved for use in series with the Y-cable KT000247A01 at connector P3. USB 4 meter data cable HKN6172_ is not approved for use in series with the Y-cable at connector P3.

4.6 Compatibility of Emergency when Attaching a Motorola Branded SB9600 Siren

When using emergency footswitch or pushbutton with siren/PA configuration, **REMOVE** pin 8 (emergency) from the siren connector of the HKN4363_ siren cable as follows:

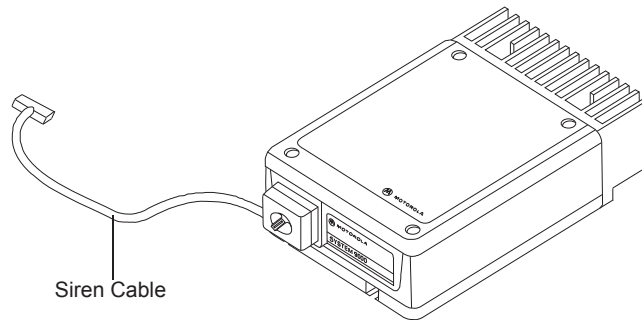

Figure 4-13. Field adjustment for Emergency Operation with Siren Accessory

1. Remove the knob from the siren/PA cable connector.
2. Remove all four screws from the connector in the siren/PA cable.
3. Open the connector cap and locate pin 8.
4. Using the contact removal tool (6684690C02), remove pin 8 from the connector.
5. Put the connector cap in place and proceed to reinstall the four screws and the knob.

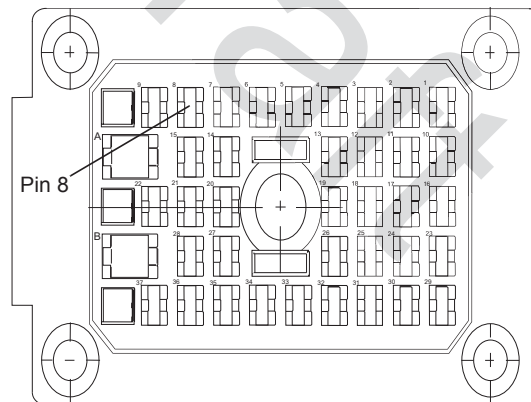

Figure 4-14. Location for Pin 8

Notes

Draft

Chapter 5 Motorcycle Radio Installation

5.1 Motorcycle Radio Description

The motorcycle model includes all the same components in the standard radio. The following paragraphs describe the unique items provided with the motorcycle models.

A small label is included with the motorcycle radio, which can be placed on the radio to identify it as a motorcycle radio. The label should be placed on a flat and protected area to avoid damage during handling. See Figure 5-1.

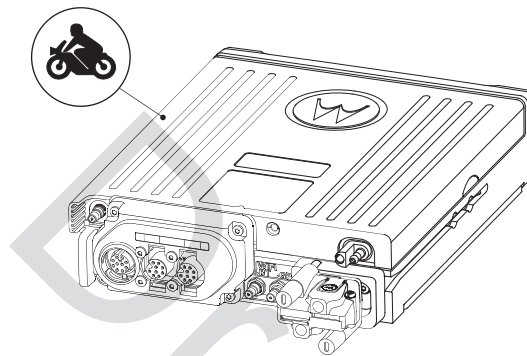

Figure 5-1. Identification of a Motorcycle Radio by Using a Label

5.1.1 Transceiver Enclosure

The transceiver is mounted in the weather-resistant enclosure that consists of a bottom housing and a hinged top cover. The top cover has a locking latch that requires a key to open. The enclosure is mounted above the rear motorcycle wheel, oriented so that the lock is forward and the hinged cover opens toward the rear of the motorcycle. The bottom housing has a grommeted hole for cable entry and weep holes to permit water drainage.

The enclosure is mounted on the motorcycle with a universal mounting plate and shock and vibration isolators. A large, braided ground-strap (installed between the mounting plate bolts and the motorcycle frame) grounds the transceiver.

5.1.2 Control/Display Unit

All radio functions, except push-to-talk (PTT), are activated from the control head, which also is weather-resistant. The control head and the external speaker are mounted for easy access near the center of the handlebars. The control head is positioned for unobstructed viewing, and it may be tilted on the horizontal axis for ease of viewing. The microphone cable port on the front of the control head is plugged and is not used.

5.1.3 Control Head Cable

The control-head cable connects the control head to the transceiver. The cable is routed along the motorcycle's frame and has weather-resistant connections at both ends. Excess cable is coiled under the transceiver inside the weather-resistant enclosure.

Each end of the cable is strain-relieved with jackscrews at the control head and the transceiver. The cable is shielded to reduce the effects of radio frequency interference and ignition sense noise.

5.1.4 Microphone

A weather-resistant, palm microphone and coiled cord plug into a pigtail connector on the control cable. The microphone attaches to a hang-up bracket located within easy reach of the motorcycle rider. The coiled cord is long enough to be operated by someone standing next to the motorcycle, yet short enough to not interfere with the motorcycle's steering or operation.

5.1.5 External Speaker

A 3.2-ohm, 10-watt-rated-audio-power, external speaker is mounted on the front of the motorcycle. The speaker cable is routed along the motorcycle frame to the transceiver's rear accessory connector. A sealed, weather-resistant, speaker-muting (toggle) switch is mounted on top of the speaker.

The external speaker connects to the rear accessory connector of the transceiver.

5.1.6 Headset Capability

The motorcycle radio is compatible with various headset accessories that provide hands-free operation of the radio. Motorola does not manufacture headset equipment, but provides the interconnection for headset equipment with the motorcycle radio. Aftermarket headset equipment is available through Motorola (see [Appendix A: Replacement Parts Ordering](#)).



Caution

To avoid loud audio, refer to the CPS help menu for audio settings if the Motorola mobile radio is used with any motorcycle helmet headset.

5.1.7 Antenna

The antenna(s) are mounted on top of the transceiver's weather-resistant enclosure. The enclosure's metal lining acts as the antenna's ground plane.

5.1.8 Ignition Sense (ACC) Wire

The ignition sense wire connects to the motorcycle's fuse box and is routed along the motorcycle frame to the transceiver's rear accessory connector.

The radio is wired so that transmission is inhibited if the motorcycle's ignition sense switch is off. If the PTT switch is pressed with the ignition sense off, a low-frequency tone sounds. The receiver is controlled by the control head on/off switch.

5.2 Installation Overview

5.2.1 General

All APX mobile radios are tested and inspected before shipment. It is, however, suggested that the transmitter frequency, deviation, and power output be checked at the time of installation. It is the license holder's responsibility to ensure that the operating parameters of his station comply with applicable laws governing radio communications equipment. For tests and alignment procedures, refer to the appropriate service manual (refer to "Related Publications").

Generally, the installation of the motorcycle radio takes place in the following parts:

- Mounting the universal mounting plate and related hardware at the rear of the motorcycle;
- Mounting the control head, speaker, microphone, and related hardware forward on the motorcycle;
- Routing the power cable, control-head cable, speaker cable, and ignition sense cable to the weather-resistant enclosure;
- Mounting the weather-resistant enclosure and radio chassis, and connecting the cables;
- Mounting the antenna(s) to the weather-resistant enclosure.

A universal mounting plate, supplied by Motorola, is first mounted to either a motorcycle carrier at the rear of the motorcycle or to the rear frame of the motorcycle itself. The mounting procedures for the universal mounting plate vary from motorcycle to motorcycle. Therefore, the procedures given in this manual for installing the mounting plate may not specifically apply, but are provided for guidance.

The control head, speaker, and microphone are mounted forward on the motorcycle, on or near the steering column. There are several possible mounting configurations which use a combination of Motorola and customer-built brackets. These configurations are outlined in this manual. Because of the large number of motorcycle makes and models in existence, the customer-built brackets are necessary to tailor the mounting of the Motorola equipment to the particular motorcycle being used. Suggestions for customer-built brackets are given in this manual.

The power cable, control-head cable, speaker cable, and ignition sense cable are routed to the weather-resistant enclosure position. The enclosure and the radio chassis are then mounted. Special care is required when connecting cables to the radio equipment within the enclosure.

5.2.2 Important Motorcycle Installation Hints

Consider the following when mounting the radio components:

- Excess lengths of control-head, power, ignition sense, and speaker cables must be routed in the enclosure as shown in [Figure 5-19](#).
- All components must be mounted securely in order to withstand the constant and sometimes severe vibration experienced on a motorcycle.
- No cantilever action, which could cause severe vibration, should be generated in the mounting hardware.
- The control head and microphone must be placed for ease of accessibility by the motorcycle operator.
- Forward components (control head, microphone, and speaker) should not interfere with visual or physical access to controls and instruments.
- Forward components should not interfere with the handling of the motorcycle.
- Cabling between the control head and the radio chassis should be run to minimize interference with operator movements.
- The weather-resistant enclosure should be placed to avoid any interference with the motorcycle operator.
- Electrical continuity must be present through the enclosure shock mounts to the motorcycle frame for proper electrical and RF grounding.
- The antenna(s) are designed for mounting on the top of the weather-resistant enclosure and an adequate metal ground plane.
- Only the supplied microphone mounting clip should be used to ensure secure mounting of the microphone. This clip has a very strong spring to ensure positive retention of the microphone over rough terrain. Also, there must be electrical continuity from this clip to the motorcycle frame for DC grounding.
- Direct access to the microphone should be provided from both sides of the motorcycle.
- Sufficient slack in the microphone coiled cord should be allowed so as not to impede steering.
- Mounting hardware must be stainless steel to prevent corrosion.
- If an extra length of cable is used to extend the microphone, ensure that the added capacitance does not interfere with the operation of the radio.
- A suitable covering should be applied to the DB-9 receptacle when the water resistant microphone (HMN1079) is not connected.

5.2.3 Parts Identification

The following installation procedures refer to [Figure 5-2](#) through [Figure 5-20](#). Detailed descriptions of the mounting hardware used in each procedure are provided in parts lists located in the exploded views located in the APX Mobile Basic Service Manual (see related documentation). Those parts supplied by Motorola are contained in one of the following kits:

- Motorcycle Weather-Resistant Microphone
- Motorcycle Weather-Resistant Speaker with Mute Switch
- Motorcycle Hardware Kit SECURENET or Motorcycle Hardware Kit
- Motorcycle Power Cable Kit
- Motorcycle Mounting Kit
- Weather-Resistant Enclosure
- Antenna

5.2.4 Order of Installation

Before starting the installation, familiarize yourself with the mounting hardware (see [Figure 5-2](#) through [Figure 5-20](#)). Perform the installation procedures in the order that follows.

1. Install the universal mounting plate on the motorcycle.
2. Install the control head and speaker.
3. Install the microphone hang-up clip.
4. Install antenna base and cable onto enclosure.
5. Install the cables.
6. Install the weather-resistant enclosure on the universal mounting plate.
7. Route the cables inside the weather-resistant enclosure.
8. Install the transceiver in the weather-resistant enclosure.
9. Install the antenna(s) on the enclosure.

5.3 Installing the Universal Mounting Plate

The universal mounting plate, supplied with the motorcycle radio, must be mounted on the motorcycle first. It provides the base on which the weather-resistant enclosure is to be mounted. The method used for mounting the plate depends on the make and model of the motorcycle and whether the plate is mounted to a carrier or to the motorcycle chassis. After the plate has been securely mounted to the motorcycle, mounting the weather-resistant enclosure onto the plate is straightforward.

Figure 5-2 illustrates the universal mounting plate mounted to a motorcycle carrier. Since there are so many makes and models of motorcycles and motorcycle carriers, it is impossible to give specific step-by-step instructions for mounting the universal mounting plate. However, noting the following considerations will aid in the installation procedure.

- A minimum of holes are predrilled into this plate as supplied. Mounting holes must be drilled as required for the particular motorcycle on which the plate is being mounted.
- The universal mounting plate should be mounted on the motorcycle in such a manner that the later mounting of the weather-resistant enclosure will not interfere with the motorcycle seat back, with any other obstacles, or with the motorcycle operator. The enclosure may be temporarily bolted to the universal mounting plate and the unit positioned on the motorcycle to ensure the above criteria are met.
- To ensure a good grounding path from the universal mounting plate to the motorcycle carrier or frame, stainless steel lock washers must be used with the mounting hardware in two areas to score through the paint on the universal mounting plate and on the carrier or frame, thereby, providing good electrical contact with the underside of the motorcycle carrier or motorcycle frame.

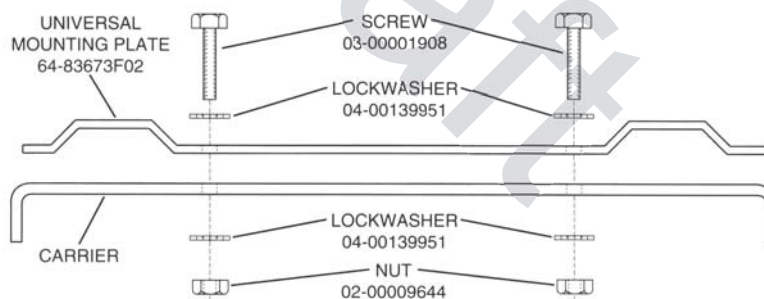

Figure 5-2. Universal Mounting Plate Installation (Part of Radio Enclosure Kit)

Follow the procedures below to mount the universal mounting plate to the motorcycle (see Figure 5-2).

1. Determine the mounting position for the mounting plate.
2. Determine whether stainless steel spacers are required for clearance in mounting the plate.
3. Drill four 9/32-inch holes in the mounting plate and the corresponding motorcycle carrier or chassis for mounting the plate.
4. Attach the universal mounting plate to the motorcycle using four machine screws, eight lock washers, and four nuts. Tighten screws securely. The lock washers must cut through the paint on the plate and motorcycle carrier or frame to ensure a good ground path.

5.4 Installing the Speaker and Control Head

NOTE: To disable the internal speaker of the O2 Control Head, please refer to [Section 2.5.1: "Internal Speaker Disassembly"](#) .

The control head mounting location and configuration is determined largely by the make and model of motorcycle. Two different mounting configurations are described below. One involves mounting the speaker and control head together as a unit using the combination speaker/control-head bracket (shown in [Figure 5-4](#)) supplied by Motorola. Alternately, the control head may be mounted by itself using a smaller control-head bracket supplied by Motorola. In this case, the speaker is mounted elsewhere. This section outlines installation procedures for each configuration mentioned above. The customer (or installer) is in the best position to determine the most appropriate mounting configuration for the control head and speaker based on the particular motorcycle on which the equipment is to be mounted.

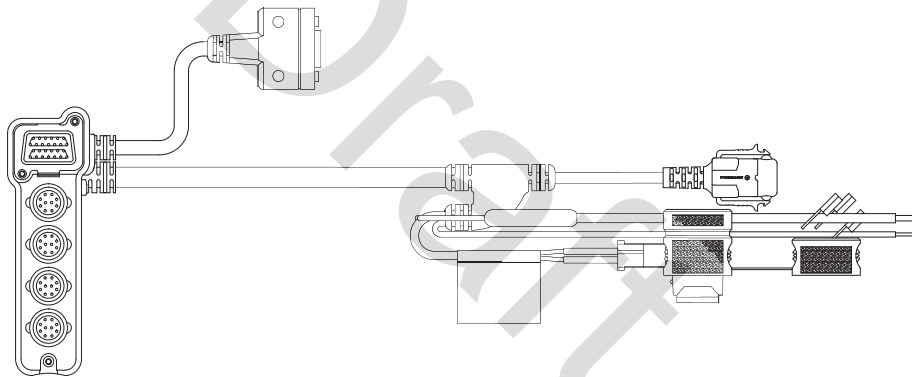
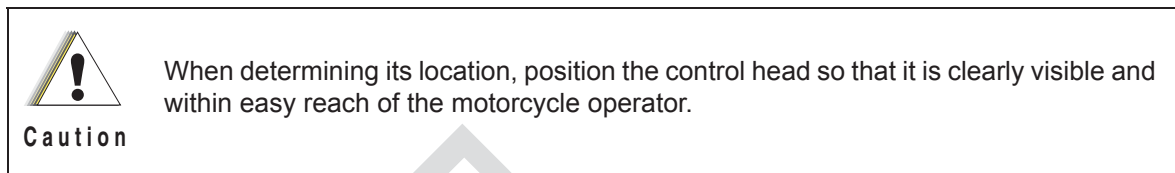

Figure 5-3. Motorcycle Control Head Cabling (3075217A01)

5.4.1 Handlebar Installation with Speaker and Control Head Mounted Together

Figure 5-4 illustrates the combination speaker/control head bracket. This combination bracket is used only when the control head and speaker are to be mounted as a unit. Also illustrated in Figure 5-4 is a handlebar-mounting bracket which may be required if the combination speaker/control-head bracket cannot be easily mounted to the motorcycle. In this case the handlebar-mounting bracket is mounted to the motorcycle, and the combination bracket is then mounted to the handlebar-mounting bracket.

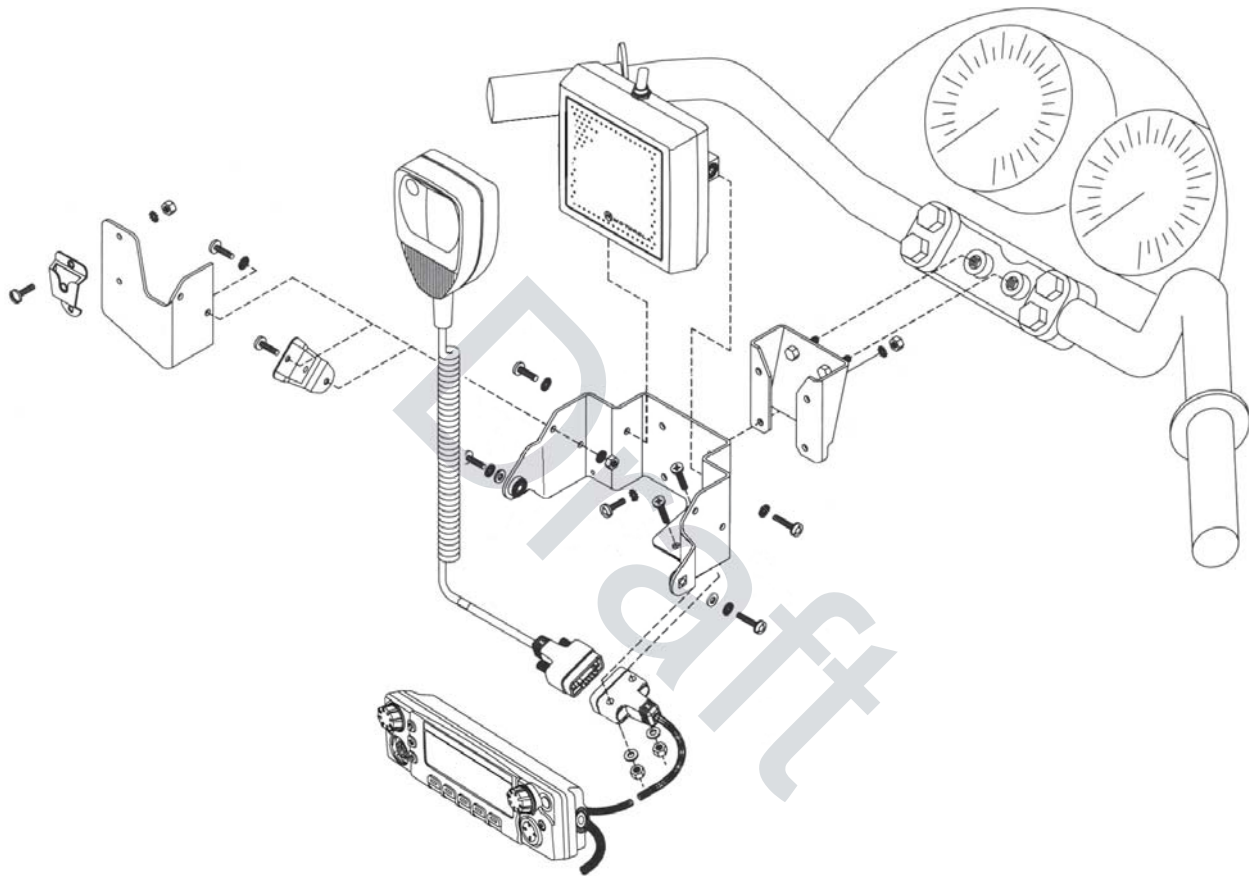

Figure 5-4. Handlebar Installation with Speaker and Control Head Mounted Together

Provision has been made on the combination speaker/control-head bracket for mounting the microphone hang-up clip. If that mounting is desired, the hang-up clip must be attached to the bracket before installing the control head and speaker. See [Section 5.6: "Installing the Microphone Hang-Up Clip"](#) for the hang-up clip procedure. Install the speaker and control head as described below.

1. Determine the location where the speaker/control head is to be mounted. Consider how the speaker/control-head bracket may be mounted, and whether or not a handlebar-mounting bracket is needed. Take care to select a location that is not only mechanically convenient, but is located for ease of operation.

NOTE: The angle at which the handlebar-mounting bracket or the speaker/control-head bracket is mounted to the motorcycle determines the firing angle of the speaker.

2. If the handlebar-mounting bracket is needed, install it first.
3. Mount the speaker/control-head bracket, either directly to the motorcycle, or, if used, to the handlebar-mounting bracket, using four stainless-steel machine screws, lock washers, and nuts.
4. Mount the 9-pin D-connector end of the motorcycle control-head cable to the speaker/control head bracket, using two machine screws, flat washers, and nuts. (Cable routing directions appear later in this section.)
5. Mount the speaker on the speaker/control-head bracket, using two machine screws and lock washers. Torque these screws to 20 in-lbs.
6. Attach the control-head cable to the control head and tighten the locking screws on the connector. This connection must be made before you mount the control head in the bracket. (Cable routing directions appear later in this section.)
7. Mount the control head to the bracket, using two machine screws, lock washers, and flat washers.
8. Adjust the control head viewing angle by loosening its mounting screws and rotating the control head to the desired angle. Then, retighten screws to 20 in-lbs torque. This concludes the speaker/control-head installation.

5.4.2 Fuel Tank Console Installation with Speaker and Control Head Mounted Together

Some motorcycles provide a console for mounting radio equipment. This console is attached to the top of the fuel tank. With the use of a mounting bracket, screws, nuts, and lock washers, the combination speaker/control-head bracket can be mounted to this console. [Figure 5-5](#) illustrates this type of mounting.

The console attachment screws must be removed, and the console must be lifted slightly from the fuel tank to gain access in order to attach mounting hardware, and to route cables later.

In this installation, the microphone (mic), mic hang-up bracket, and mic extension bracket will interfere with handlebar travel.

Installation using this method is the same as in [Section 5.4.1: "Handlebar Installation with Speaker and Control Head Mounted Together"](#).

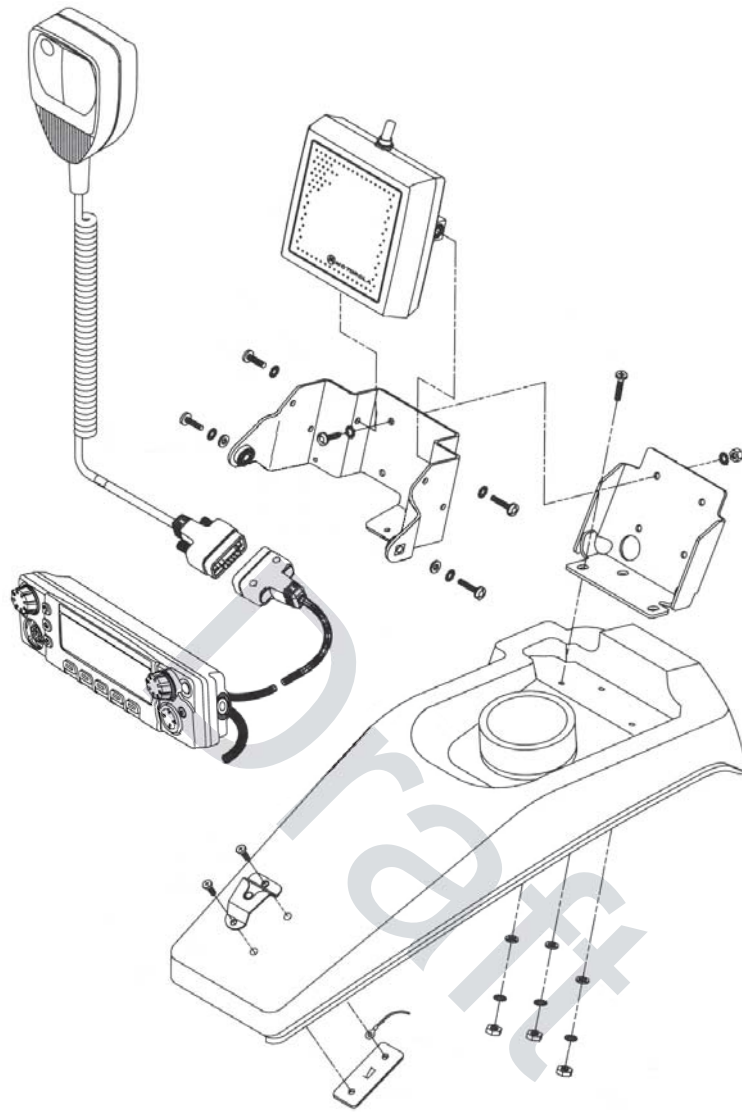

Figure 5-5. Fuel Tank Console Installation with Speaker and Control Head Mounted Together

5.4.3 Handlebar Installation with Speaker and Control Head Mounted Separately

It may be necessary to use the smaller control head bracket (part number 07-80127N02) and mount the speaker and microphone hang-up clip in another location on the motorcycle.

Before installing the control head using the bracket described above, the control-head end of the control-head cable should be temporarily fastened to the control head, and the control head fastened to its bracket. Motorola-supplied spacers and the mic-cable bracket are required to mount the control head to the handlebar. This mic-cable bracket has holes to mount the microphone-cable connector.

Follow these procedures when mounting the smaller control-head bracket:

1. Determine the location at which the control head is to be mounted. Take care to choose a location that is not only mechanically convenient, but is located for ease of operation.
2. Securely mount the Motorola-supplied spacers, mic-cable bracket, and small control-head bracket to the handlebars.
3. Mount the 9-pin D-connector end of the motorcycle control-head cable to the mic-cable bracket, using two machine screws, flat washers, and nuts. (Cable routing directions appear later in this section.)
4. Attach the control-head end of the cable to the control head and tighten the locking screws on the connector.
5. Mount the control head to the small control-head bracket, at the proper viewing angle, using two wing screws. **Tighten firmly.** This concludes the control-head installation.

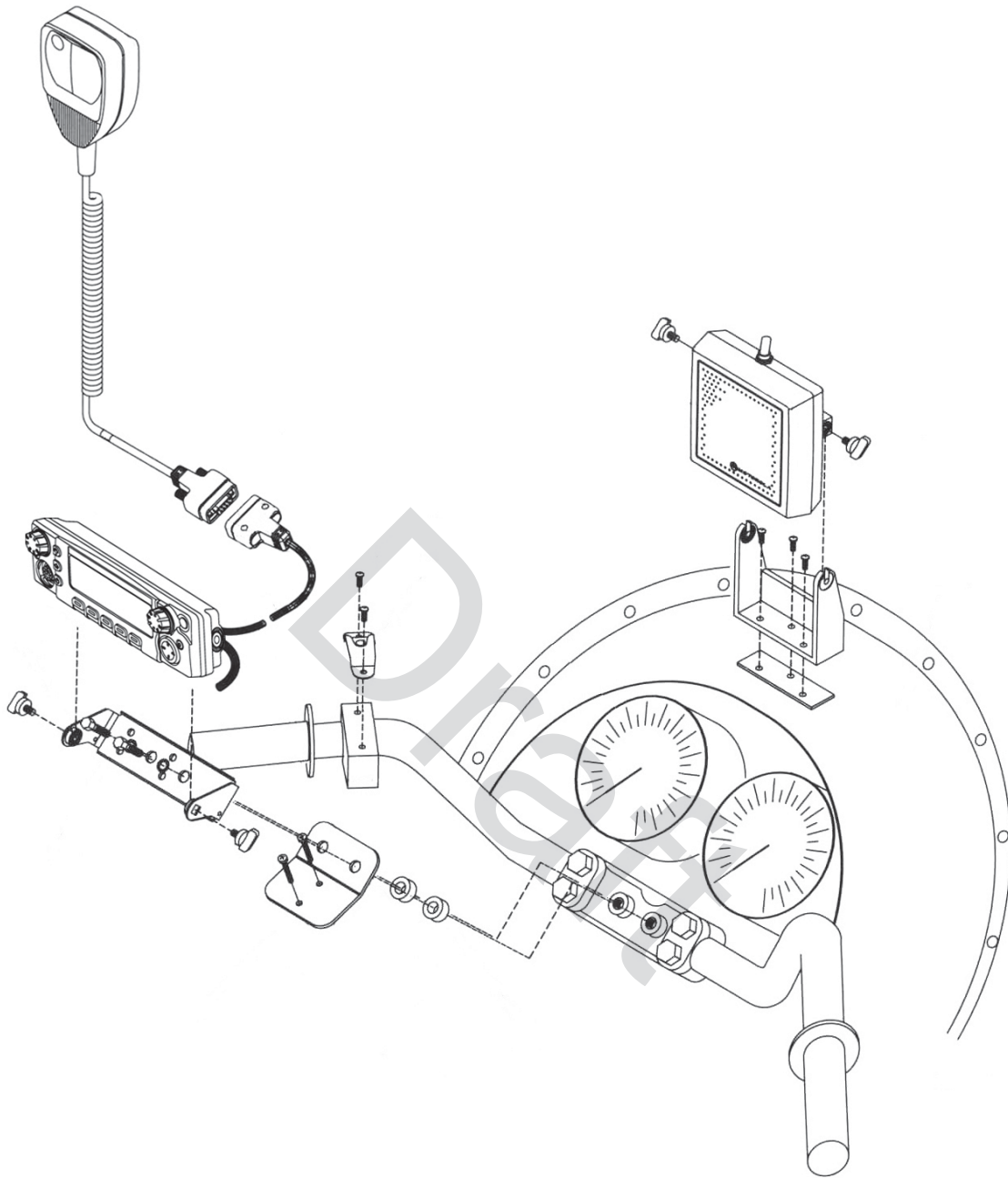

Figure 5-6. Handlebar Installation with Speaker and Control Head Mounted Separately

5.4.4 Fuel Tank Console Installation with Speaker and Control Head Mounted Separately

The control head may be mounted to the fuel tank console using the smaller control-head bracket and spacers/hardware. In this configuration, the microphone cable connector may be attached directly to the console, eliminating the need for a custom bracket.

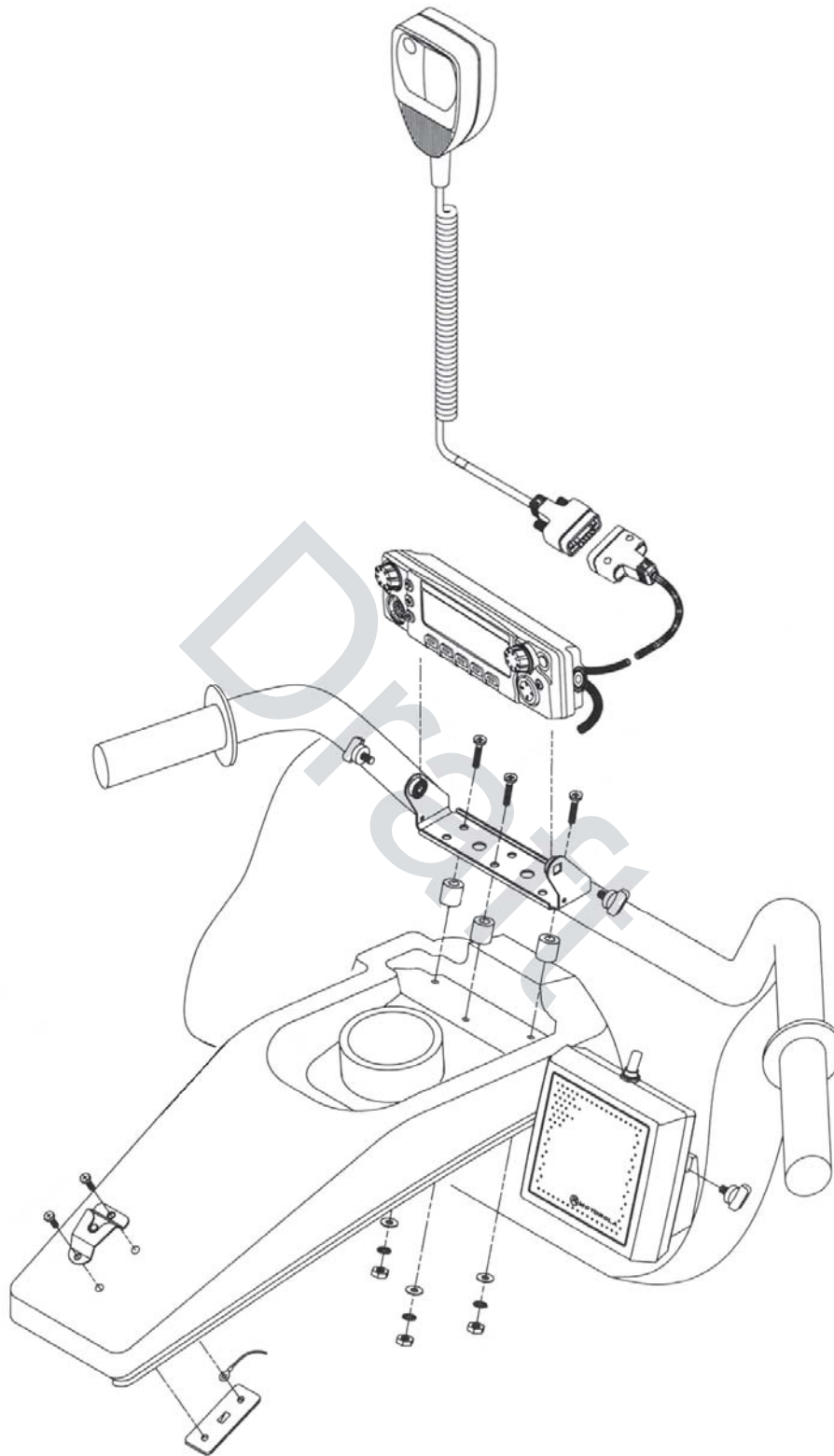

Figure 5-7. Fuel Tank Console Installation with Speaker and Control Head Mounted Separately

Installation is the same as detailed in [Section 5.4.2: “Fuel Tank Console Installation with Speaker and Control Head Mounted Together”](#) and [Section 5.4.3: “Handlebar Installation with Speaker and Control Head Mounted Separately”](#) .

5.5 Installing the Speaker

NOTE: To disable the internal speaker of the O2 Control Head, please refer to [Section 2.5.1: "Internal Speaker Disassembly"](#) .

Use the following procedure when the speaker is mounted separate from the control head. The speaker bracket supplied with the speaker may be used alone if a suitable location can be found, or if necessary, a customer-supplied bracket may be fabricated for mounting the speaker.

1. Determine the location in which the speaker is to be mounted and whether there is a requirement for a customer-supplied bracket.
2. Fabricate a bracket if required. Use the Motorola-supplied speaker bracket as a template for drilling mounting holes. Also drill holes in the fabricated bracket for mounting to the motorcycle.
3. Mount the fabricated bracket to the motorcycle chassis.
4. Mount the Motorola-supplied bracket to the fabricated bracket using two machine screws, flat washers, lock washers, and nuts.
5. Mount the speaker to the speaker bracket using two wing screws. Directions for speaker cable routing appear later in this section. Speaker mounting is now complete.

5.6 Installing the Microphone Hang-Up Clip

Install the hang-up clip either on the supplied microphone extension bracket or on the side of the speaker/control head bracket. Both methods are shown in [Figure 5-4](#). Determine the mounting location and install as described in the following paragraphs.

NOTE: Wherever the hang-up clip is mounted, it must be DC grounded for proper operation. After mounting the clip, be sure there is electrical continuity between the clip and the motorcycle chassis.

5.6.1 Extension Bracket Mounting

Using this method, you can mount the clip so that it faces the operator.

1. Attach the bracket to the speaker/control-head bracket using two machine screws, four lock washers, and two nuts as shown in [Figure 5-4](#).
2. Torque nuts to 20 in-lbs torque.
3. Fasten the hang-up clip to the extension bracket using two machine screws, lock washers, and nuts as shown in [Figure 5-4](#).
4. Torque nuts to 20 in-lbs torque.

5.6.2 Speaker/Control Head Bracket Side Mounting

Attach the hang-up clip to the left side of the speaker/control-head bracket using two machine screws, lock washers, and nuts as shown in [Figure 5-4](#). Torque nuts to 20 in-lbs. torque.

5.6.3 Other Hang-Up Clip Mounting

To mount the microphone hang-up clip in another location, a customer-supplied bracket may be used. Suggested locations include the handlebars, fuel-tank console, or any location which provides easy access to the microphone without blocking controls and indicators and without interfering with motorcycle handling. See [Figure 5-5](#), [Figure 5-6](#), and [Figure 5-7](#) for alternative microphone hang-up clip mounting methods.

1. Fabricate a bracket, then secure it to the motorcycle.
2. Use two machine screws, lock washers, and nuts to secure the hang-up clip to the customer-supplied bracket. Ensure that the microphone clip is DC grounded to the motorcycle chassis (a grounding lug and strap are provided in the hang-up clip kit for this purpose) – this is essential for proper radio operation.

5.7 Installing Antenna Base, Cables and Multiplexer

NOTE: Antenna hole placement and cable routing in 700/800, VHF and UHF antenna manuals are not applicable for the APX Series.

The GPS antenna assembly must be done after the removal of the metal liner but before reinstalling the APX Series liner.

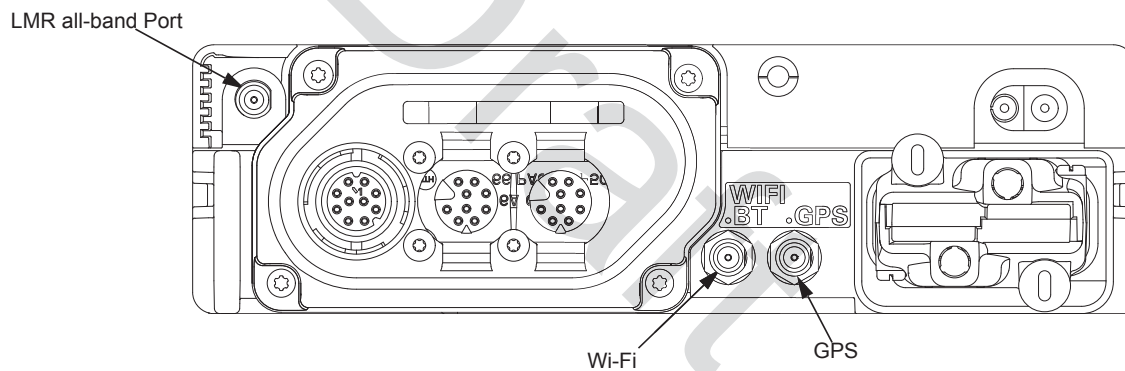

Figure 5-8. Antenna Band Identification

1. Open the top cover of the weather-resistant enclosure.
2. Uninstall the metal liner that is shipped attached to the weather-resistant enclosure. This liner has one depressed area at the top of the enclosure liner just toward the rear of the enclosure. This metal liner is not used with APX Series products.
3. Place the metal liner with two round, depressed areas toward the enclosure hinge and 1 inch hole near the front of the housing, inside the top cover, and align the six slots in the metal liner with the screw holes in the top housing.
4. The metal liner of the enclosure's top cover acts as a ground plane for the antenna.
5. Locate the two round, depressed areas about 3 inches in diameter in the metal liner near the enclosure hinge. Referring to [Figure 5-9](#), these areas are either VHF or UHF depending on the antenna port locations. For the GPS antenna, use the 1 inch hole near the front of the housing near the lock.

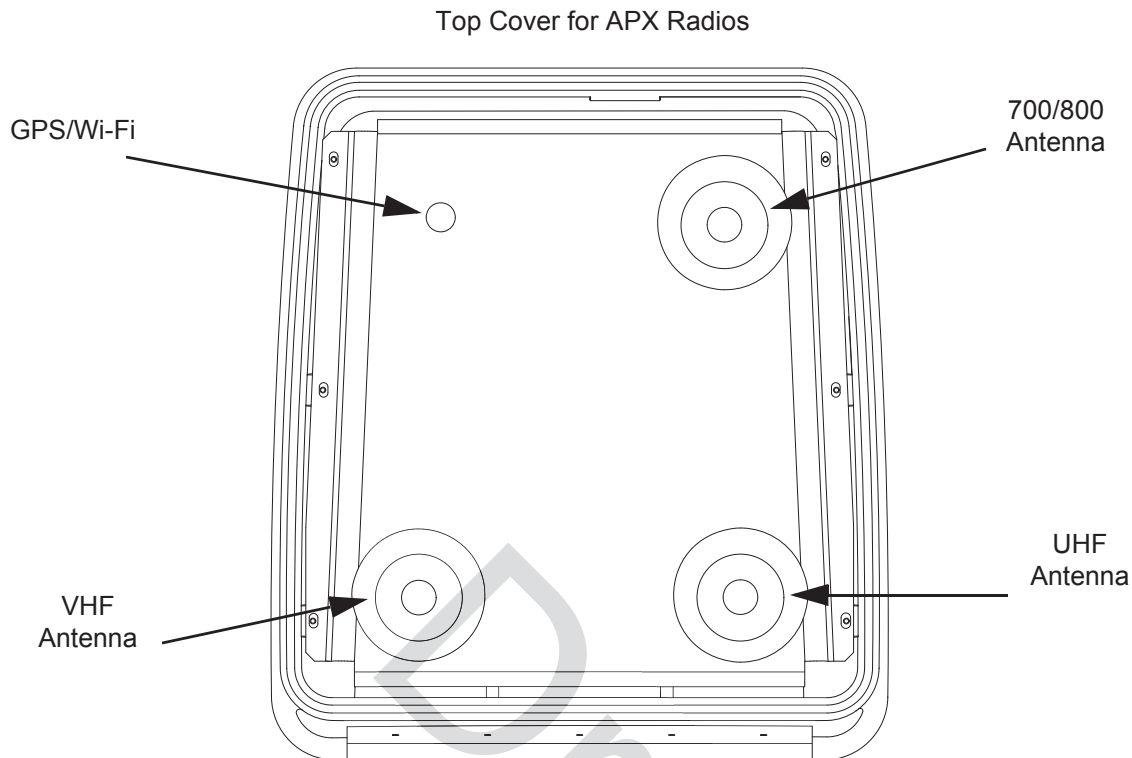

Figure 5-9. Antenna Port Locations

6. These holes in the metal liner is used as a template to mark the position of the hole(s) to be drilled at the top cover. Follow the below guidelines for the various options.
7. Remove the metal liner from the top cover.
8. For LMR all-band antenna, use the Motorola RPX-4378A Hole-Cutting Saw or equivalent, and carefully drill a 3/4-inch hole at the marked location from the inside of the cover until the saw bottoms out. For the GPS/WiFi carefully drill a 1 1/16-inch hole at the marked location from the inside of the cover until the saw bottoms out. The saw should clean a neat circle to assure good contact between the antenna and the housing.

IMPORTANT: For proper seating of the antennas, deburr and scrape any foreign matter from both sides of the hole, being careful not to mar the finish of the shell.

9. Clean the mounting surface around the hole to remove dirt and wax.
10. Refer to the Motorcycle GPS Instruction Manual for further installation instruction for the GPS. GPS must be mounted before the APX metal liner is installed.
11. Reinstall the APX metal liner with the cable clamps provided in the weather-resistant housing.
12. Attach the 700/800, VHF or UHF antenna base per Antenna Installation Manual.

IMPORTANT: Antenna Placement and Cable Routing in the Antenna Installation Manual is not applicable for the APX series.

13. Route the coaxial cable for the 700/800, VHF or UHF antenna(s) through the cable clamps per [Figure 5-11](#) for VHF hole, [Figure 5-12](#) for 700/800 hole and [Figure 5-13](#) for UHF hole.



Caution Be sure to observe the correct routing of the antenna cable. Failure to do so can damage the cable.

14. After routing cable, allow enough of the cable to reach the radio's antenna connector and cut off any excess length of the cable.
15. Install the connector per Antenna Installation Manual.

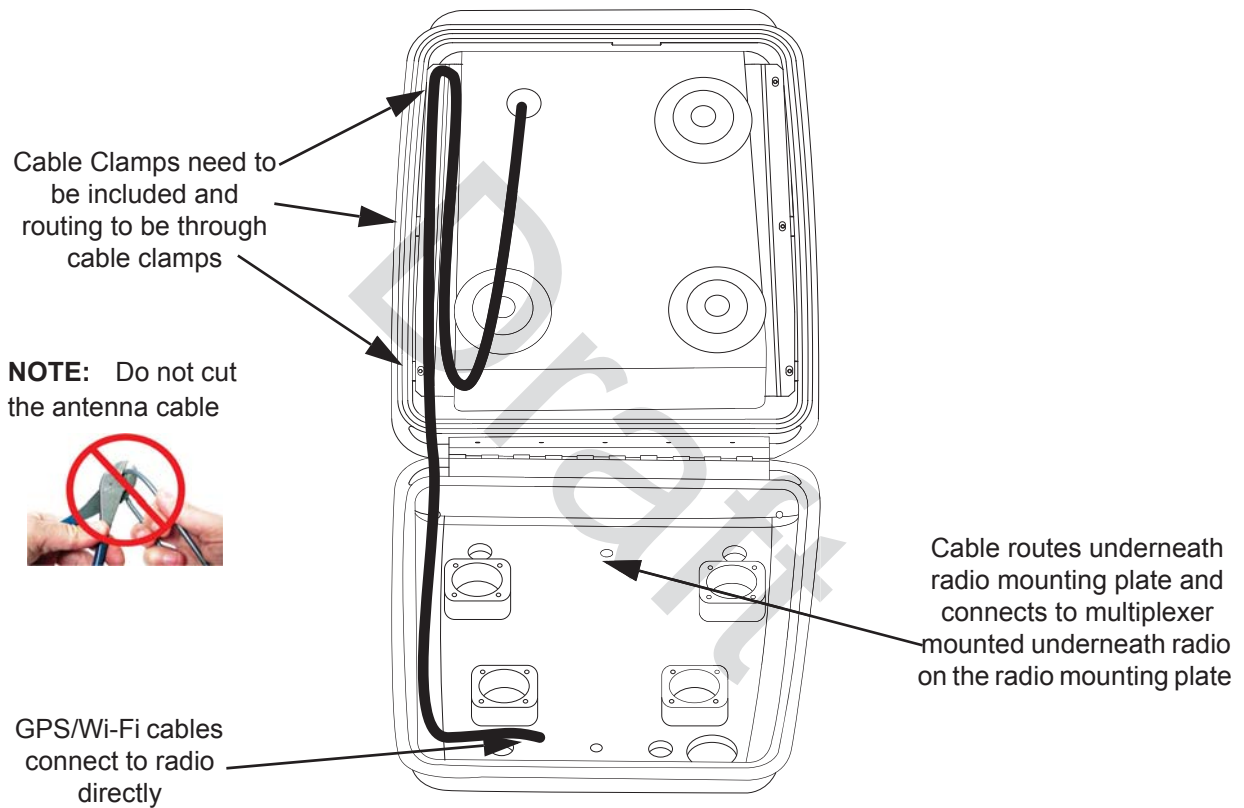

Figure 5-10. Routing the GPS/Wi-Fi Cable

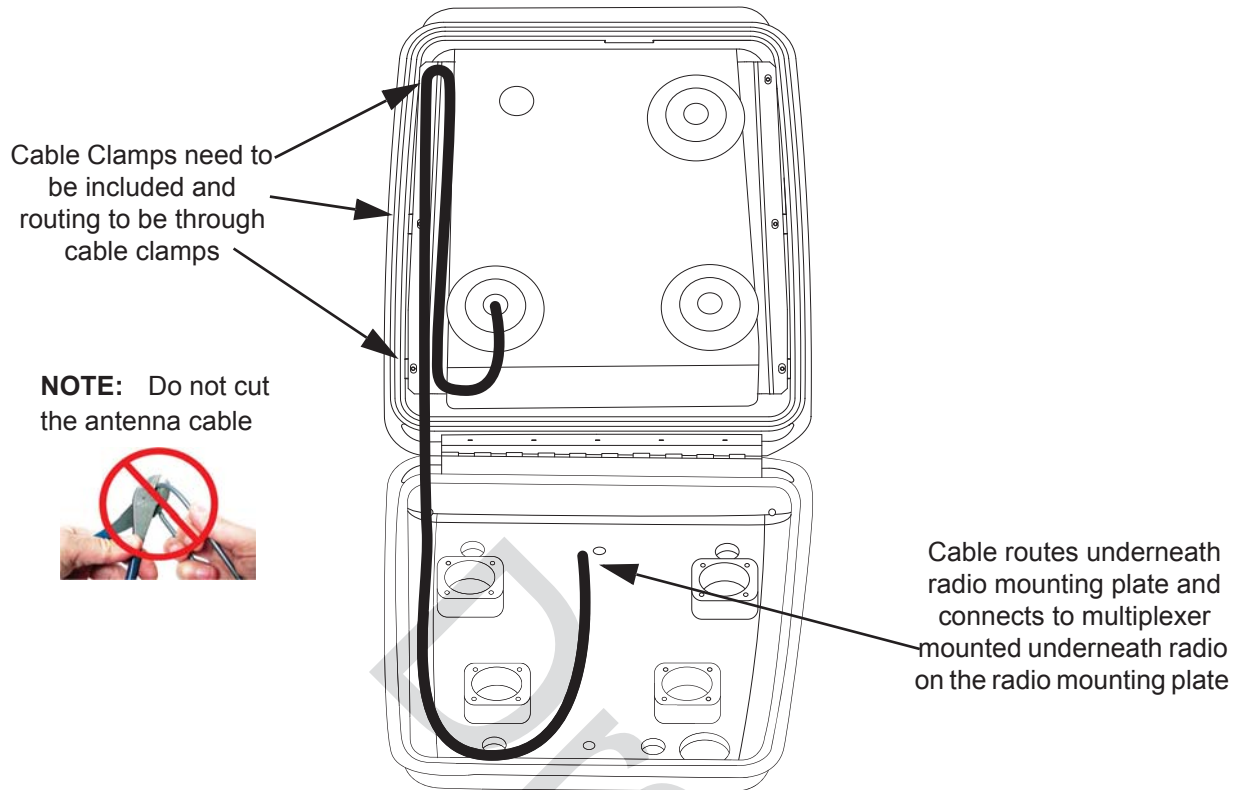

Figure 5-11. Routing the VHF Antenna Cable

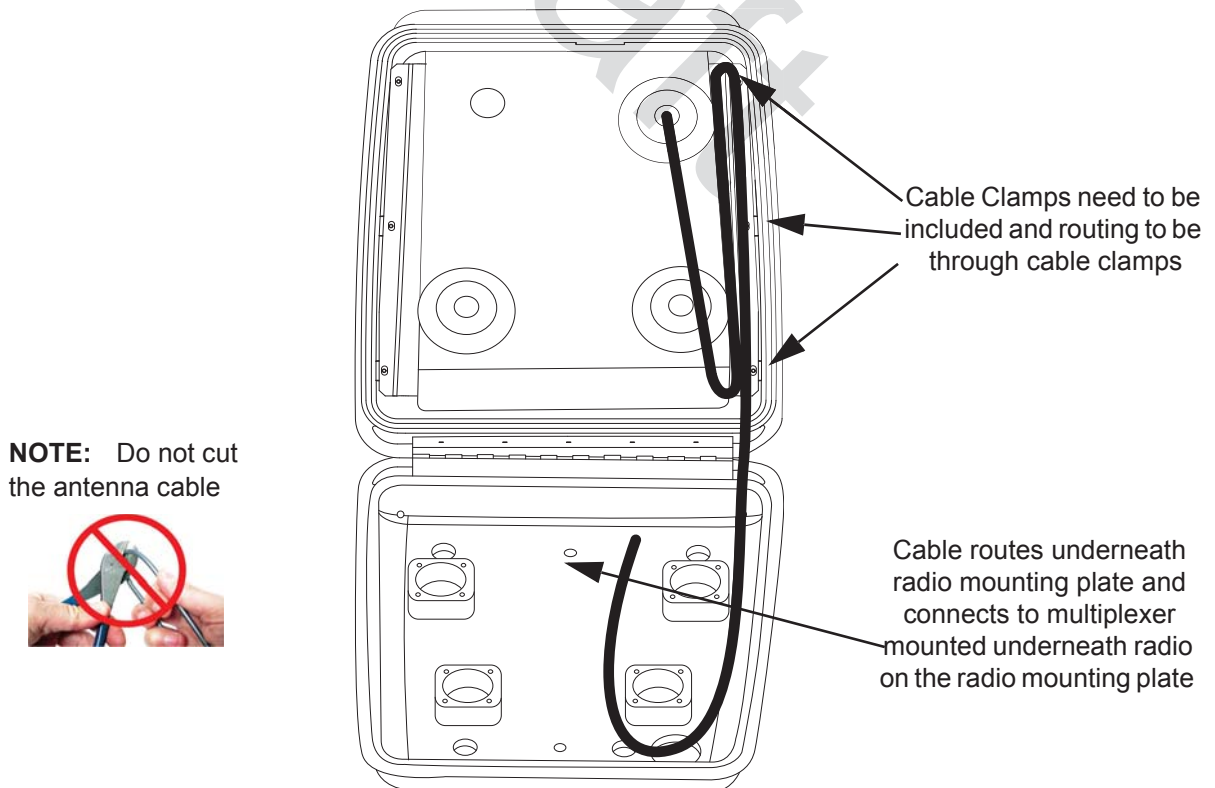

Figure 5-12. Routing the 700/800 Antenna Cable

NOTE: Do not cut the antenna cable

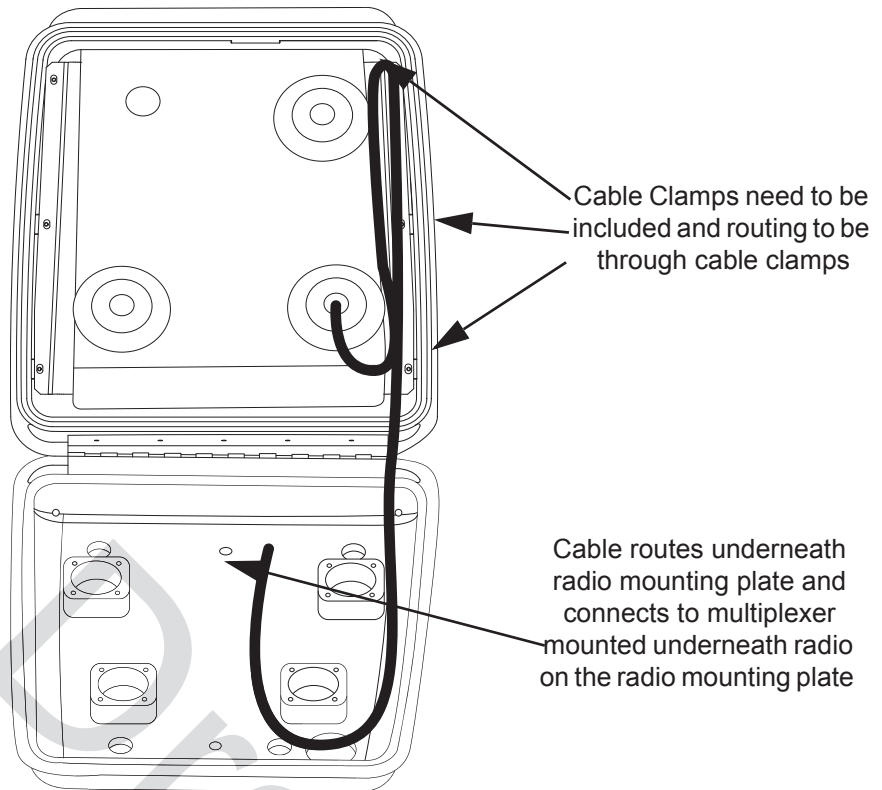

Figure 5-13. Routing the UHF Antenna Cable



Figure 5-14. Multiplexer and Trunion Mounting

NOTE: Do not cut the antenna cable



Figure 5-15. Cable Routing

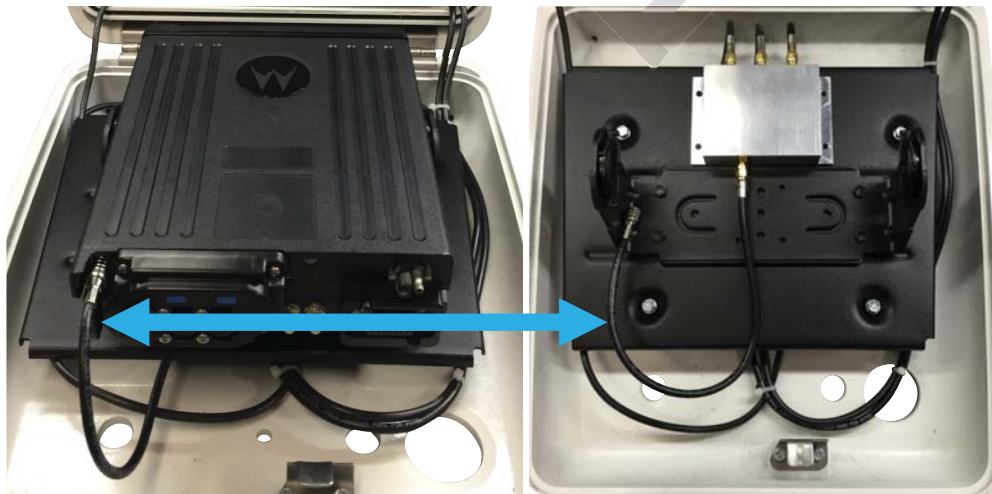

Figure 5-16. Cable from Radio to Multiplexer

NOTE: Radio has to be mounted with the TIB facing the front of the enclosure

5.8 Installing the Antenna

IMPORTANT: Antenna Placement and Cable Routing as described inside the Antenna Installation Manual is not applicable for the APX radio series. Refer to information listed below.

- Connect the appropriate antenna connectors to the antenna receptacles on the radio. Tighten the coupling until fully engaged.

5.9 Cable Routing

Five cables must be installed to interconnect the components of the radio system as shown in Figure 5-17. The antenna cable is routed away from the other cables inside the enclosure's hinged cover (see Section 5.7). The four remaining cables, routed along the motorcycle frame, are described in the following paragraphs.

NOTE: Antenna Hole Placement and Cable Routing information in the Antenna Installation Manual is not applicable to the APX series.

Removal of the fuel tank and seat from the motorcycle will facilitate routing the cables along the frame. Motorcycles with consoles attached to fuel tanks require routing cables between console and fuel tank. In this case the tank is not removed.

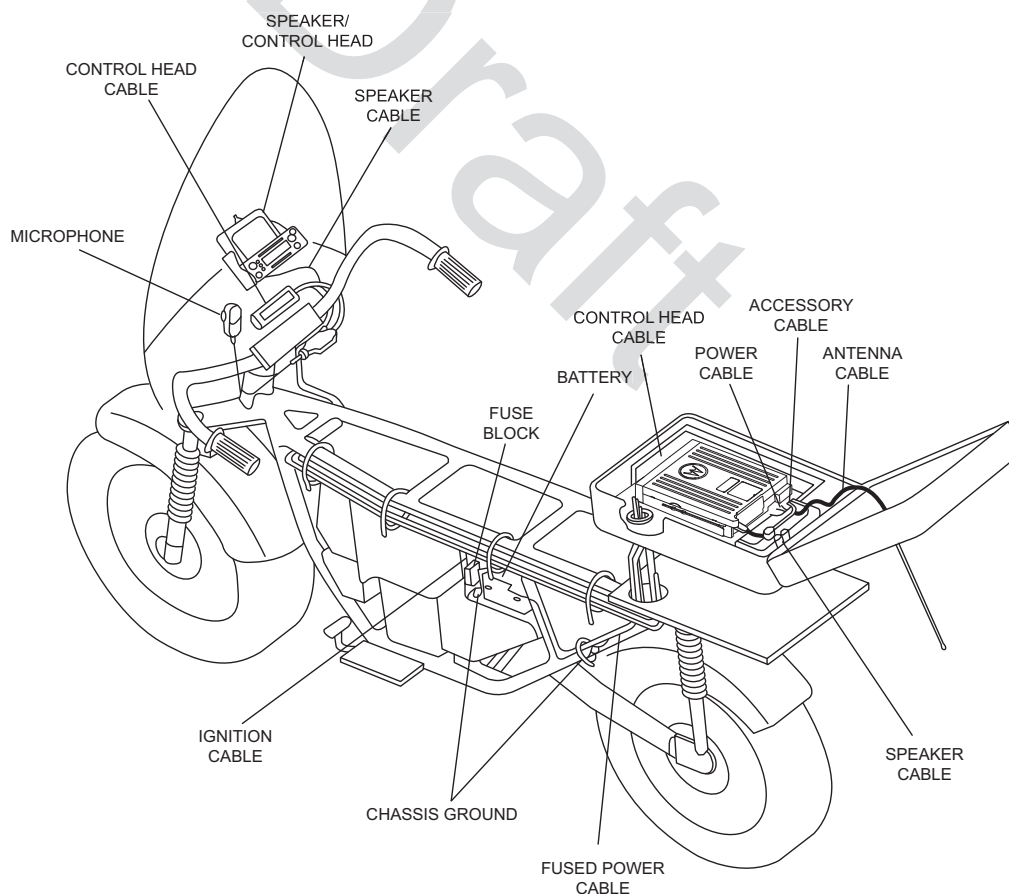

Figure 5-17. Cable Routing

1. **Speaker Cable** – runs from the speaker to the accessory-cable connector inside the weather-resistant enclosure.

2. **Control Cable** – runs from the rear of the control head to the front of the transceiver inside the enclosure.
3. **Ignition Sense (Red) Wire Portion of Accessory Cable** – runs from the ignition sense fuse terminal of the fuse box to the rear area inside the enclosure. The lug for attaching the ignition sense wire is contained on the accessory cable.
4. **Power Cable** – The red, unterminated end runs from the positive terminal of the battery to the power connector that plugs in the rear of the transceiver. Lugs for attaching the red and black leads are contained in the motorcycle power-cable kit. The black, unterminated end runs from a suitable motorcycle chassis ground to the power connector. **DO NOT** connect the black lead directly to the negative battery post.

You may route the cables in any order. As you route each cable, temporarily fasten it at both ends. When all cables have been run, permanently fasten the cables with appropriate cable tie wraps. Observe the following during routing and hook-up:

1. Route the cables so that none interfere with motorcycle operation.
2. Fasten the cables with supplied nylon tie wraps. The wraps should be firmly installed at frequent intervals along the cable length in such a manner that motorcycle vibration will not cause metal fatigue and subsequent breakage of the cable wires.
3. Take care to position cables away from parts of the motorcycle that get hot.

Bundle excess cable length inside the weather-resistant enclosure as discussed later in [Section 5.11: "Transceiver, Cabling and Multiplexer Installation"](#).

The fifth cable is the microphone with coiled cord. Plug the 9-pin D-connector end of the coiled cord into its mating connector, which was attached near the control head discussed in an earlier paragraph. Tighten the coiled-cord-retention screws. Insert the S-hook strain relief (terminated to the coiled cord) into the hole in the mounting bracket. Slide the microphone into the microphone hang-up bracket.

5.10 Installing the Weather-Resistant Enclosure

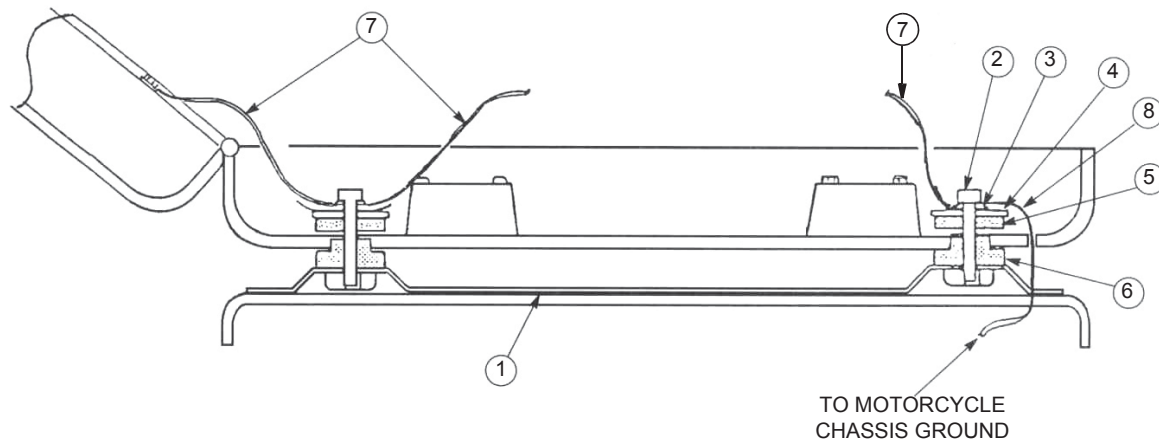

Item No.	Description	Item No.	Description
1	Universal Mounting Plate	5	Flat Rubber Washer
2	Machine Screw	6	Shouldered Rubber Washer
3	Lockwasher	7	7-1/2-inch Ground Strap
4	Flat Washer	8	Ground Strap

Figure 5-18. Weather-Resistant Enclosure Installation

1. Remove the radio-mounting plate by removing four screws, lock washers, and flat washers.
2. The weather-resistant enclosure is mounted to the universal mounting plate using shock mounts. Assemble the shock-mount components exactly as shown in Figure 5-18. Be sure to install ground straps between the shock-mount and the transceiver trunnion mount, and install one 7-1/2-inch ground strap between the right rear mount and the enclosure lid's antenna ground plane 0 (shown in Figure 5-18 and in Figure 5-20).
3. The order of assembly is important to ensure proper shock mount operation. All components are supplied with the mounting kit. The five 7- 1/2-inch straps are used on the rear and front shock mounts – four from shock mount to trunnion, and one from the shock mount to the lid's antenna ground plane.

NOTE: Grounding through the power-supply cable is NOT sufficient. Whether the radio transceiver is mounted to a carrier or the chassis itself, the transceiver MUST be properly grounded to the motorcycle chassis. The ground strap supplied with the installation kit may have to be used to ensure a good RF ground path from the radio transceiver to the motorcycle chassis.

4. Install the 3-foot ground strap on one of the front shock mounts. Route it through the cable-routing hole and connect the other end to the motorcycle frame (see Figure 5-18).

 WARNING	<p>DO NOT connect the ground strap directly to the negative battery post.</p>
---	--

5. The diagram of the shock mount is shown loosely assembled. After the hex screws are tightened, the rubber washers are compressed to fasten the weather-resistant enclosure securely to the universal mounting plate.
6. [Figure 5-20](#) is an exploded view of the enclosure; it shows details that will help to understand how the enclosure is mounted. After the enclosure is completely mounted, check for proper ground connection—continuity between the antenna ground plane and the motorcycle frame.

5.11 Transceiver, Cabling and Multiplexer Installation

After the weather-resistant enclosure has been installed, the radio chassis (transceiver) is installed in the enclosure and then appropriate cables are connected. However, before the transceiver can be installed, the cabling must be properly positioned in the enclosure.

5.11.1 Installing Cabling in the Enclosure

Position the cabling in the weather-resistant enclosure as follows:

1. Run the speaker, power, control-head, and ignition sense cables into the enclosure.
2. Lay the excess cable length between the radio mounting bosses in an S configuration as shown in [Figure 5-19](#). Do not coil any excess cable. Use the supplied tie wraps to bundle cable as shown.

NOTE: If the extra cable length is not sufficient to match the illustrated cable routing, then match the illustration as closely as possible.

3. Connect the speaker cable to the accessory cable connector.

NOTE: The accessory-cable emergency connector is shipped with a shorting plug installed. The headset connector is also shipped with a shorting plug installed. The plugs must remain in if an emergency switch and/or headset is not used. If an emergency switch and/or headset is used, remove the shorting plug(s) and discard.

4. Install the mounting plate in position on top of the cables installed above. Take care not to damage or pinch the cables when securing the mounting plate in position.

NOTE: At this point, the control-head cable plug should be located at the forward end of the enclosure, and the power-cable, speaker-cable, and accessory-cable plugs should be located at the rear of the enclosure.

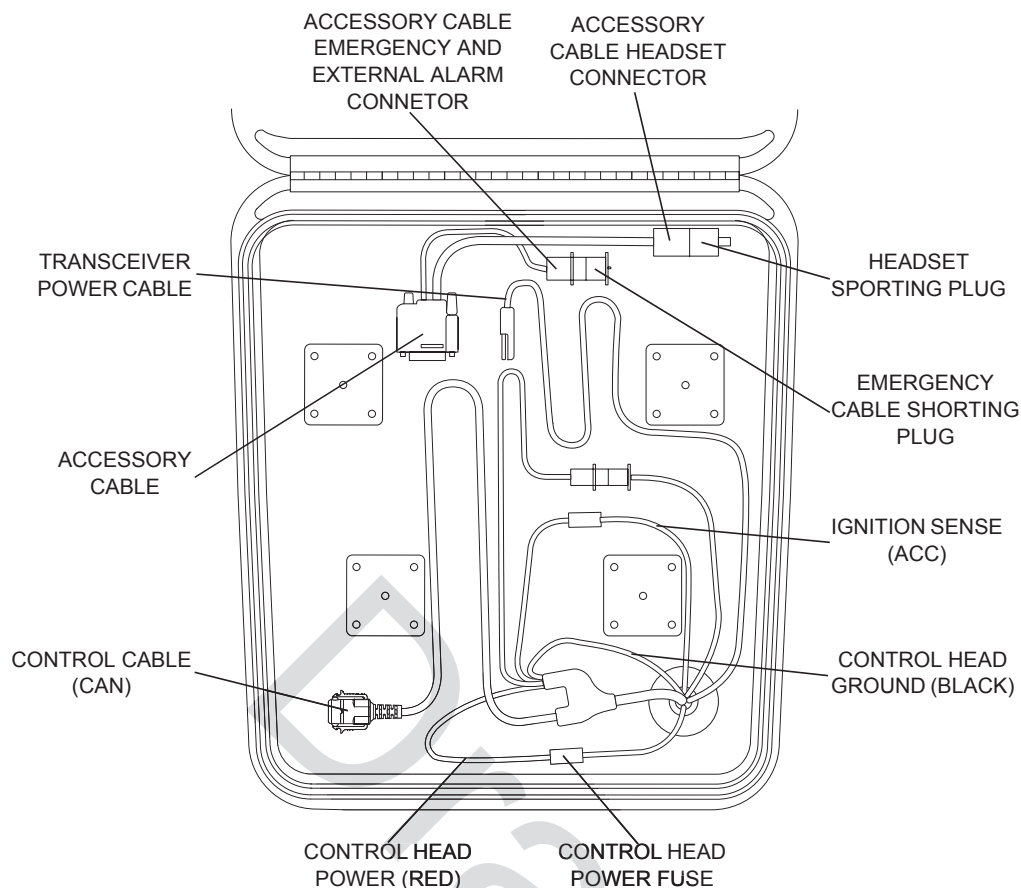

Figure 5-19. Installing Cables

5.11.2 Installing the Transceiver

Install the transceiver in the weather-resistant enclosure as follows (see [Figure 5-20](#)).

NOTE: For new or existing installations, use only the APX mobile trunnion (kit number: HLN7002_).

1. Install the mounting trunnion and loose ends of the four ground straps to the radio-mounting plate, using four screws, flat washers, and external-tooth lock washers (see [Figure 5-20](#)). The ground straps must be sandwiched between the flat washers and lock washers. The lock washer must be against the trunnion. The flat washer must be under the screw head.
2. Attach the transceiver to the mounting trunnion and secure with the two screws provided.
3. Connect the control cable to the front of the transceiver. Ensure the control-cable connector screws are tightened.
4. Attach the accessory connector to the transceiver. Plug in the power connector.
5. Install the grommet around the cables and push the grommet into the cable-routing hole of the weather-resistant enclosure.

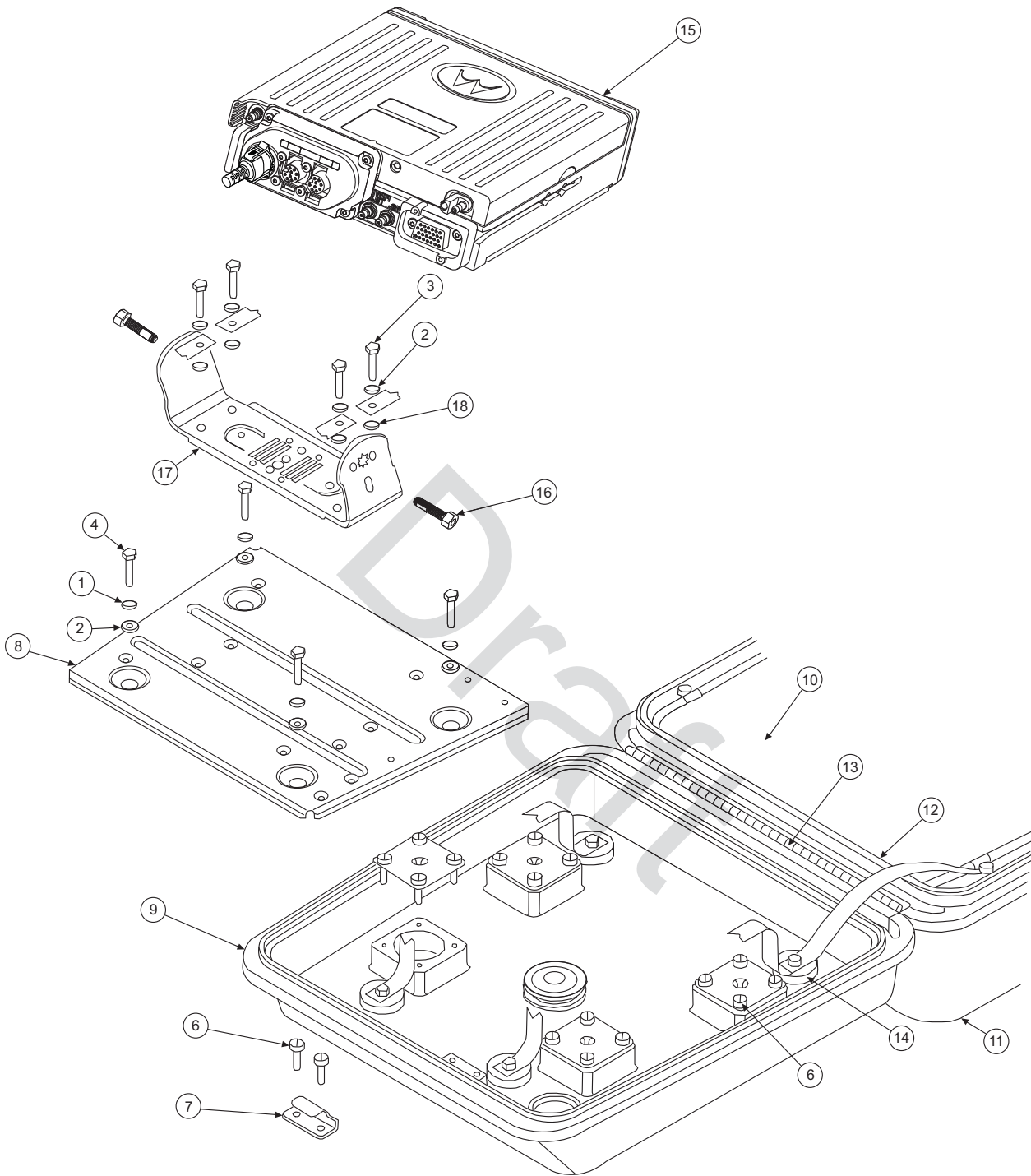

Figure 5-20. Installing the Transceiver

Table 5-1. Transceiver Installation Parts List

Item No.	Description	Item No.	Description
1	Lock washer	10	Ground shield plane
2	Flat washer (8 used)	11	Top cover
3	Screw	12	Gasket
4	Screw	13	Hinge
5	Grommet	14	Enclosure mounts
6	Screw	15	Transceiver
7	Lock catch	16	Screw
8	Radio mounting plate	17	Trunnion
9	Bottom housing	18	External tooth lock washer (8 used)

5.12 Installing the Emergency Switch Option

Use the two-conductor, green/black cable which has as one end terminated with two contacts (part number 3080221P02) and which is supplied with this W688 Motorcycle Emergency Push Button. Disconnect the emergency switch shorting plug from the accessory cable. Replace the shorting wire of the shorting plug with the terminated end of the green/black emergency cable. Reconnect the plug to the accessory cable.

5.13 Installing the External Alarm Relay Option

The motorcycle radio is offered with only one optional relay connection. If both horn and lights are required, wire a second relay coil parallel to the first relay. Use the two-conductor green/black cable which has one end terminated with two contacts (part number 3080221P02) and which is supplied with this W116 Motorcycle Alarm Relay Option. Insert the contacts into positions 3 and 4 of the emergency shorting plug of the accessory cable. Refer to [Figure 5-26](#).

5.14 Installing the Headset Accessory

A six-position connector on the accessory cable has been made available for connecting a headset accessory. Headset manufacturers should be consulted for compatibility with the motorcycle radio prior to purchase and installation of the headset. To install, disconnect the headset shorting plug. Remove the headset shorting wire from the headset shorting plug. Terminate the contacts provided to the applicable wires of the headset cable. Insert the terminated wires into the headset shorting plug per the contact positions illustrated in the typical headset schematic found in this manual. Reconnect the terminated headset shorting plug to the accessory cable.

When upgrading from an APX mobile radio, the existing headset cable HLN6890 requires these two pins to be swapped (see [Figure 5-21](#)). The other motorcycle headset cable with this pin change already performed is called cable 3080010R04.

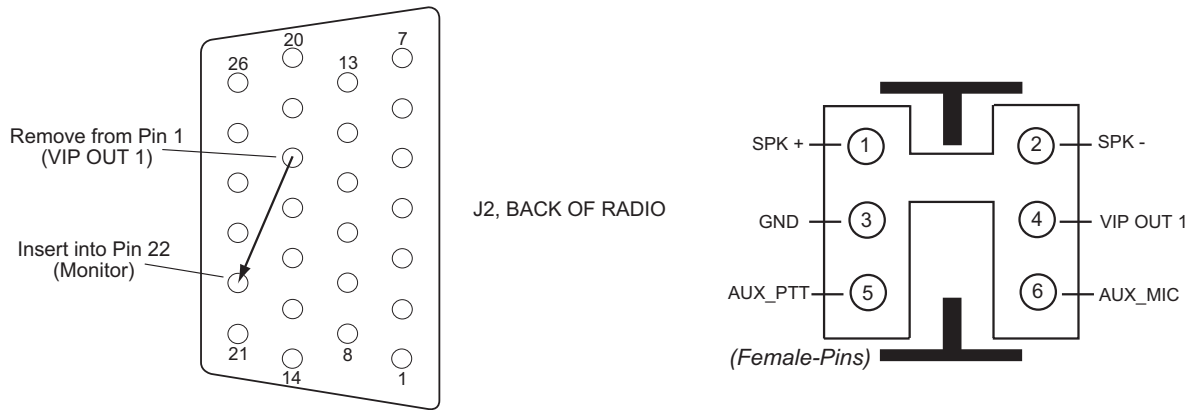

Rework for Handlebar HUB operation when upgrading existing cable HLN6890.

Figure 5-21. Motorcycle Wiring Harness Rework

Draft

5.15 Installing the O5 Control Head Sunshield

Install the sunshield (part number NNTN7279_) to the O5 control head as follows.

1. Assemble the sunshield to the remote mount trunnion as shown in [Figure 5-22](#). The same process can be used for the motorcycle trunnion.

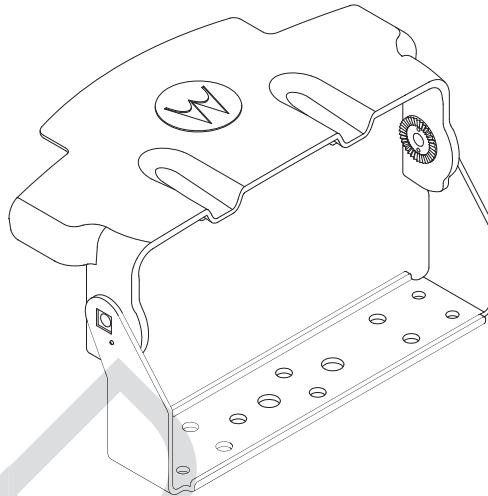

Figure 5-22. Remote Mount Trunnion with Sunshield

2. Position the sunshield as shown in [Figure 5-23](#) and remove the Velcro adhesive backing.

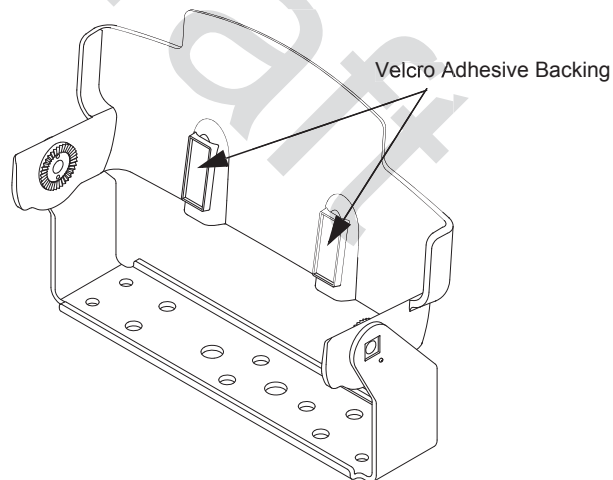

Figure 5-23. Position the Sunshield

- Slide the control head onto the trunnion while aligning the edge of the control head with the edge of the sunshield as shown in [Figure 5-24](#). Make sure the Velcro properly adheres to the control head.

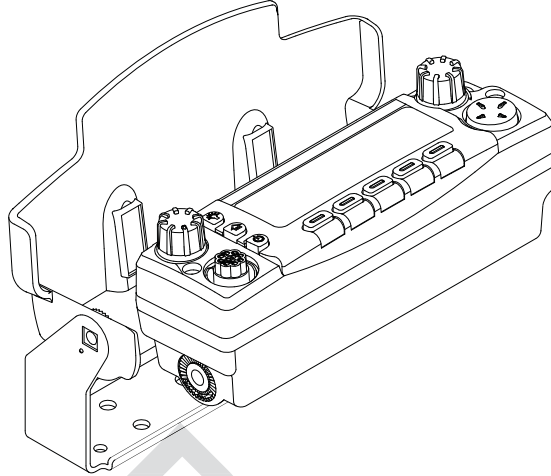

Figure 5-24. Slide the Control Head onto Trunnion

- Position control head as desired and install screws as shown in [Figure 5-25](#).

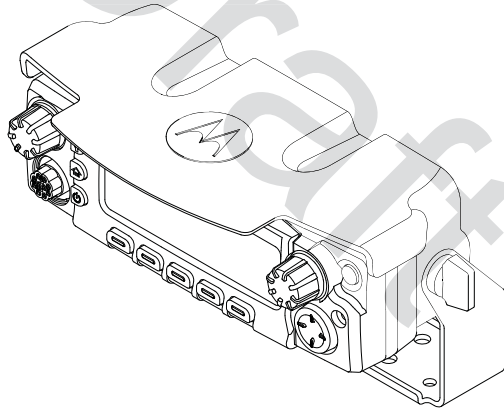

Figure 5-25. Position Control Head as Desired

5.16 Horn/Lights Wiring

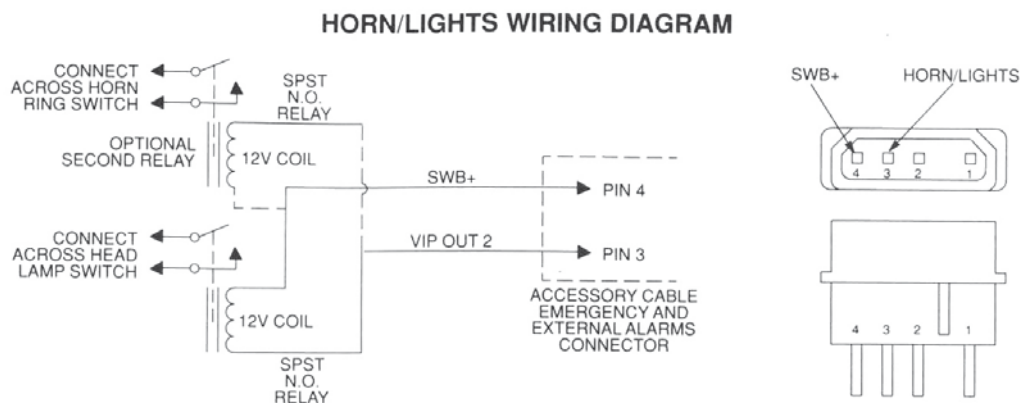

Figure 5-26. Horn/Lights Wiring Diagram

5.17 Emergency Switch Wiring

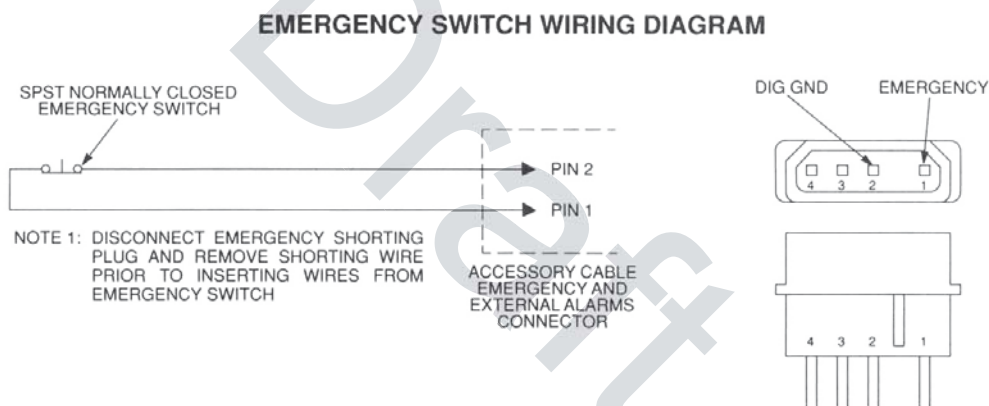



Figure 5-27. Emergency Switch Wiring Diagram

 WARNING	<p>Motorcycle products must have pins 1 and 2 connected together to allow the radio to power down. Opening this connection by REMOVING the emergency shorting plug, or pressing the emergency switch, will turn on the radio. Failure to maintain a normally-closed path could drain the vehicle battery if left unchecked.</p> <p>EMERGENCY-equipped radios are capable of TRANSMITTING without warning.</p>
---	--

Draft

Chapter 6 Finishing the Installation

6.1 Cable Connection

6.1.1 O2 Control Head

Perform the following if it has not been previously done:

1. Remove the control head from its mounting trunnion. Plug the radio's CAN cable into the proper location on the back of the control head (see [Figure 2-21](#) and [Figure 2-23](#) in Chapter 2). The connectors “click” when snapped into place. The control head model can have the microphone plugged into the lower left corner of the control head front panel.
2. Connect the plug from the speaker lead to the mating connector coming out of the power cable.
3. Plug the VIP connector into the correct location on the back of the control head.
4. Connect the CAN cable to the proper location on the transceiver.

NOTE: Connector-protective covers are provided with the radio. They should be used for added environmental robustness.

Be sure the control head and microphone PTT switches are OFF. Install the 15-amp fuse in the radio power cable fuseholder and the 3- or 4-amp fuse(s) in the ignition sense cable fuseholder(s).

Turn the radio **ON** at the control head and verify proper operation of all controls and indicators. Radio operation in some installations require turning on the ignition sense. Perform a complete operational check of the radio.

Dress the control and power cables out of the way to prevent damage (pull any excess cable into the trunk area) securing with clamps and tie wraps where necessary.

6.1.2 O3 Control Head

Perform the following if it has not been previously done:

1. Unplug the CAN coiled cable connector on the Transceiver Interface. Plug in the connector again. A “click” sound should be heard. Ensure location of CAN connector is correct (i.e. J800L or J800R) on the transceiver interface.

Connect the plug from the speaker lead to the mating connector of J2.

6.1.3 O5 Control Head

Perform the following if it has not been previously done:

1. Remove the control head from its mounting trunnion. Plug the radio's CAN cable into the proper location on the back of the control head (see [Figure 2-21](#) and [Figure 2-23](#) in Chapter 2). The connectors “click” when snapped into place. The control head model can have the microphone plugged into the lower left corner of the control head front panel.
 2. Connect the plug from the speaker lead to the mating connector coming out of the power cable.
-

3. Plug the VIP connector into the correct location on the back of the control head.
4. Connect the CAN cable to the proper location on the transceiver.

6.1.4 O7 Control Head

Perform the following if it has not been previously done:

1. Remove the control head from its mounting trunnion. Plug the radio's CAN cable into the proper location on the back of the control head (see [Figure 2-21](#) and [Figure 2-23](#) in Chapter 2). The connectors “click” when snapped into place. The control head model can have the microphone plugged into the lower left corner of the control head front panel.
2. Connect the plug from the speaker lead to the mating connector coming out of the power cable.
3. Plug the VIP connector into the correct location on the back of the control head.
4. Connect the CAN cable to the proper location on the transceiver.

6.1.5 O9 Control Head

Perform the following if it has not been previously done:

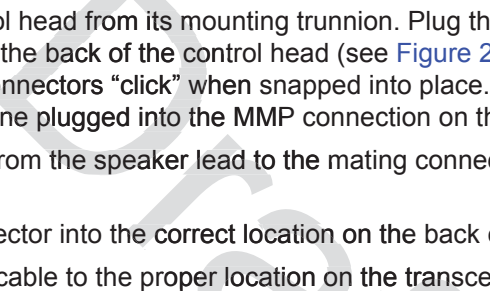
1. Remove the control head from its mounting trunnion. Plug the radio's CAN cable into the proper location on the back of the control head (see [Figure 2-22](#) and [Figure 2-23](#) in Chapter 2). The connectors “click” when snapped into place. The control head model can have the microphone plugged into the MMP connection on the control head back panel.
 2. Connect the plug from the speaker lead to the mating connector coming out of the power cable.
 3. Plug the VIP connector into the correct location on the back of the control head.
 4. Connect the CAN cable to the proper location on the transceiver.
- 

6.2 Dust Cover Installation

To help protect and ensure debris does not effect or damage your unused connectors, please use the provided dust covers. Refer to [Figure 6-1](#) to determine which cover is for which connector.

Table 6-1 Dust Cover Kit Number

Kit Number	Description
KT000245A01	Dash Mount
KT000246A01	Remote Mount

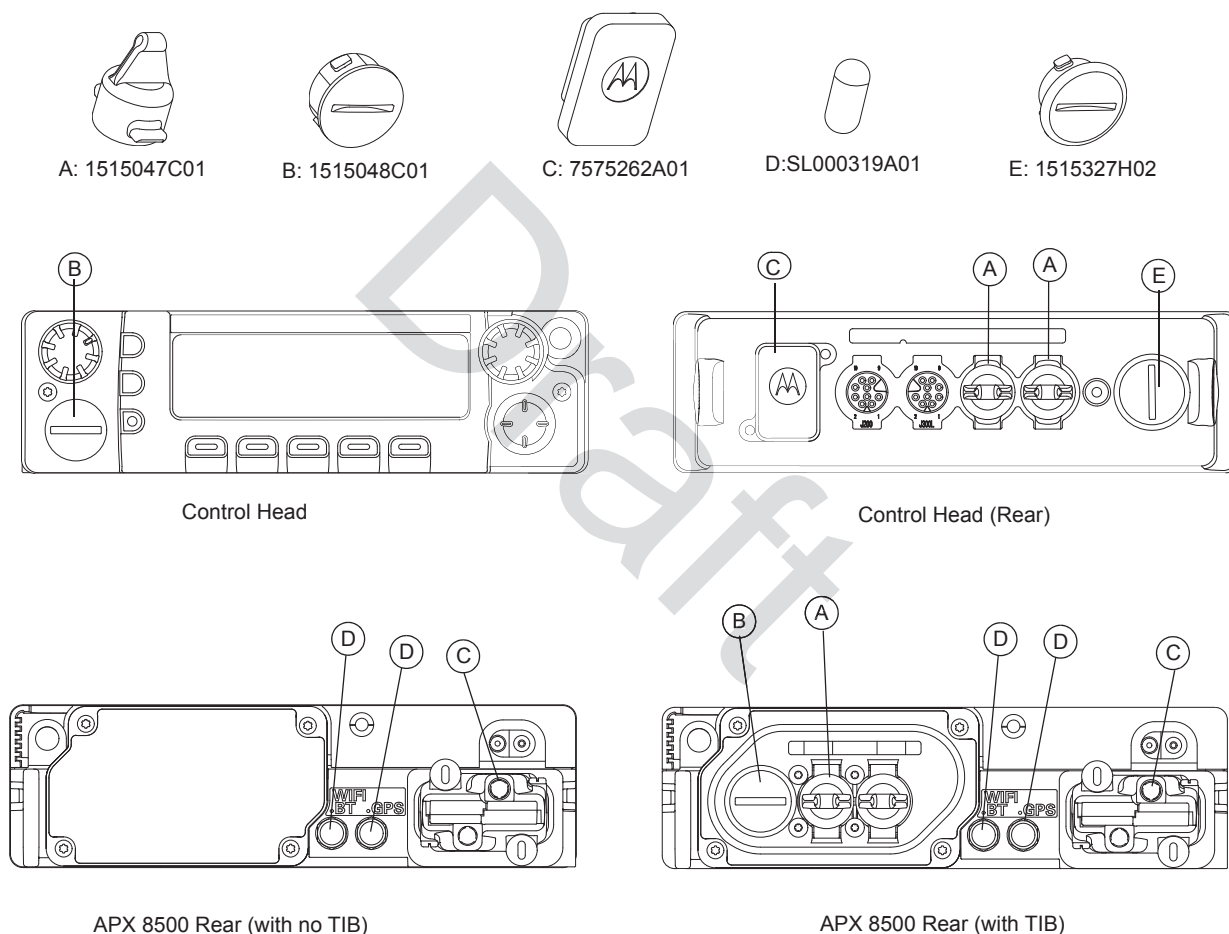

Figure 6-1. Dust Cover Installation Locations

NOTE: Parts B and E require inserting then turning approximately 1/3 turn using a coin as a tool until it contacts the stop.

Part C shall be installed onto DB25 accessory cable assembly when the corresponding cable assembly connection is not in use.

Draft

Chapter 7 Best Practices: Installation & Troubleshooting

In this section are Motorola recommended vehicle installation practices that can address or prevent many issues, including:

- Radio circuit damage due to over voltage condition
- Radio/Accessories "lock up"
- Radio/Accessories change state/lock-up when radio PTT is depressed
- Radio powers up in the FL 01/90 state (general communication error code)
- Radio intermittently resets
- Radio loses secure key
- Transmit audio distortion on motorcycle radio when engine is running
- Keypad buttons become inoperative for motorcycle radios when engine is running
- Alternator whine present when transmitting with engine running
- Radio/Accessories turn themselves on/off

7.1 Check Wiring of Ignition and Radio Ignition Sensing

- If it is required to turn the radio on and off via the ignition sense switch, in addition to the control head's on/off switch, connect the ignition sense lead to the accessory terminal from the ignition switch (usually in the vehicle's fuse panel under accessory or radio).

NOTE: Motorola Solutions recommends protecting or isolating the radio's ignition sense input from voltage spikes in excess of +/- 40VDC. Such spikes can be hundreds of volts in amplitude and are common in larger vehicles (utility trucks, buses and etc.), especially when the source is common to a solenoid coil. A triggerable oscilloscope is required to determine the existence of such spikes as most voltmeters cannot measure in short duration (< 1 msec). If the condition of the intended ignition sense source is unknown, Motorola Solutions recommends isolating the source from the radio with a relay or the use of a suppression diode wired between the source and ground. Any high current suppression diode (i.e. MR2535) with a breakdown voltage of between 18 and 40 volts will suffice. A suitable diode kit is available from Motorola Solutions parts, kit number HLN6325_.

- If it is required to have the radio power up only via the control head's on/off switch, then connect the ignition sense lead directly to the positive terminal of the battery. This will mean the ignition sense will always be ignored and a re-wiring will be necessary in the future if the operator chooses any ignition sense CPS setting.
-

7.2 Check Physical Installation of Radio Ground and Radio Accessory Wiring

- Take care to scrape away paint on the chassis at the place where the ground connection is to be made, and try to keep the ground lead as short as possible.

NOTE: Some vehicles have dedicated ground points. If available, use the ground points for the radio ground connection.

- Verify that the A+ lead (red) is connected directly to the positive terminal of the battery and the ground lead (black) is connected to the vehicle's chassis using as short of a length of wire as is practical.
- For vehicles that have other types of electronic equipment installed (lights, flashers, computers siren/PA and etc.), use a separate ground for the mobile radio equipment.
- Make sure that the mobile radio antenna is the minimum required distance (three feet) from the mobile radio equipment to prevent radio frequency interference (RFI) from interfering with the radio and/or accessories.

NOTE: If multiple radios/antennas are installed, ensure that the minimum antenna separation requirements are met.

- Do not coil up any excess length of the A+ (red) lead. Doing this may cause a large transient voltage to be produced when there is a high current drain (e.g. during transmit). This could cause the radio to reset when the push-to-talk (PTT) is depressed.
- For motorcycle mounted radios, make sure that the antenna ground connection is solid. An intermittent ground connection can cause the transmission to be distorted when the motorcycle's engine is running.
- Do not coil up any excessive length of antenna cable, if possible. It may affect the radio's receive performance.
- If an extra length of cable is used to extend the microphone, make sure the added capacitance does not interfere with the operation of the radio.

7.3 Improve the Electrical Quality of the Power and Ignition Lines

- Use a relay to isolate the vehicle's ignition switch point (ACC) from the radio's ignition sense point. Control this relay from the vehicle's ignition switch point (ACC). Supply a cleaner voltage from the positive terminal of the battery into the relay, which will now be attached to the radio's ignition sense point. Now the ACC line toggles the relay, instead of directly toggling the radio's ignition sense line.
- Install a Power Line Filter between the A+ lead and the positive terminal of the battery. This is intended to filter the battery power applied to the transmitter power amplifiers. Pay extra caution to this because the series filter will introduce a negative spike when the radio transmits that may cause problems with radio operation.
- For vehicles that use electromechanical relays to control external devices (lights, motors, switch boxes and etc.), these relay circuits should be isolated as best as possible from the mobile radio equipment. Also, diode suppression should be used across the relay contacts to minimize the noise produced by the collapsing magnetic field.
- If the ignition sense switch is to be used, make sure that there is not a large voltage drop between the A+ point (usually the positive terminal of the battery) and the ignition sense point. In general, the voltage difference between these two points, should not be greater than 1.5 volts when all accessories/air-conditioner, etc. are turned on. Refer to the Basic Service Manual for specifications for minimum and maximum voltage levels. Typical battery voltage levels are 13.6V +/- 20%.

7.4 Minimize the Effect of Poorly Grounded Antennas

- For vehicles with high power radios that use glass mount antennas, care must be taken to keep the radio and antenna cable as far as possible from the radiating element of the antenna. If a sufficient distance is not maintained, the glass mount antenna's lack of a proper ground plane may cause the radio's transmit signal to interfere with itself and cause a reset. To minimize this effect, it may be necessary to install ferrite beads on the antenna cable to protect the radio from this interference.

7.5 Jump-Start the Vehicle



Caution

Do not jump-start vehicle with radio power or ignition sense cables connected. Damage to the radio and/or accessories may result.

Jump-starting a motorcycle can crank **300+ volts** through the vehicle's charging system and these transients can damage electrical equipment.

The state of your radio prior to needing a jump-start may be unknown, and the radio may attempt to return to its last state (radio ON), when doing a jump-start. Therefore, Motorola recommends the following steps be taken before jump-starting any vehicle containing a radio.

1. Locate the ignition sense line (thin yellow wire or thin red wire, depending on dash mount or remote mount installation) and the main power leads (thick red wire) near the battery positive terminal.

NOTE: These lines are fused. In the event these lines are not fused (add the appropriate fuse in line) use whatever tools necessary to physically disconnect the ignition sense and power lines from the battery terminal.

Make sure that the disconnected lines are not in the way of moving motorcycle parts or interfering with the motorcycle operation in any way.

2. Open up the fuse holders and remove the fuses out of the kits.
3. Re-tighten the fuse holders but without the fuses to insure that ignition sense and power lines do not interfere with moving motorcycle parts.
4. Proceed with the jump-start routine as described by your vehicle owner's manual.
5. Once the jump-start process is complete, re-install the fuses into their holders.

7.6 Eliminate Noise/Howling from PA Speaker

1. Refer to [Section 2.1.1](#) for recommended methods of installation available for the mobile two-way radio, with accessories placed on or inside the vehicle.
2. Refer to [Section 2.1.2](#) for the wiring diagrams for the recommended configurations.
3. Refer to the Siren/PA User Manual for further details on lowering the wattage.

Notes

Draft

Appendix A Replacement Parts Ordering

A.1 Basic Ordering Information

When ordering replacement parts or equipment information, the complete identification number should be included. This applies to all components, kits, and chassis. If the component part number is not known, the order should include the number of the chassis or kit of which it is a part, and sufficient description of the desired component to identify it.

The ASTRO APX Mobile Radio Basic Service Manual includes complete parts lists and part numbers.

Refer to Table of Content for applicable manual numbers.

A.2 Motorola Online Service and Support

For general support, users can access

- http://www.motorolasolutions.com/en_us/support.html
- http://www.motorolasolutions.com/en_us/contact-us.html
- http://www.motorolasolutions.com/en_us/products/two-way-radios/project-25-radios/mobile-radios/apx8500.html
- Motorola Online Website: <https://businessonline.motorolasolutions.com/>



The screenshot displays the Motorola Online Americas website. At the top left is the Motorola logo, followed by the text "MOTOROLA ONLINE AMERICAS". Below this is a navigation bar with a warning: "MOL performs best using Internet Explorer. IE8+ does require users add MOL to their browser's Compatibility View settings. CLICK HERE to be redirected to Microsoft's website for steps to update IE Compatibility View settings." The main content area features a "Motorola Online Login" form on the left with fields for "User ID" and "Password", each with a "Forgot" link, and a "Login" button. Below the form is a link for "Sign Up Now" and a "Contact Us" link. On the right is a large graphic with the Motorola logo and the text "MOTOROLA SOLUTIONS".

To register for online access:

- Domestic customers: please call 800-814-0601 (U.S. and Canada).
- International customers: please go to <https://businessonline.motorolasolutions.com/> and click on "Sign Up Now."

- ECAT

Motorola SOLUTIONS

Home | Buying Center | Resource Center | Training | Order Mgmt | My Carts | Repair Center | Account Status | Settings | Case Mgmt

Change

Home > Resource Center
(800) 814-0601 Contact Motorola Solutions for your customer care needs.

RESOURCE CENTER

Advanced Search
ecat

- Contacts and Locations
- General Business Information
- Price Book Information
 - ECAT (Electronic Catalog)
 - Select Systems
 - APB (Above the Price Book)
 - ASTRO 25 RF Site Products
 - PCR Direct/List Pricing
 - RNSD
 - Services
 - Product Information
 - Software
 - Marketing Information
 - Training

Price Book Information > ECAT (Electronic Catalog)

ECAT (Electronic Catalog)

US ECAT Electronic Catalog (15 Sep 2016 Application 120MB)
This is a monthly copy of the U.S. Electronic Catalog (ECAT) which includes detailed product information.

Motorola Product Catalog ECAT_DUP_Sep_2016.exe

ELECTRONIC CATALOG

Motorola Product Catalog
2016

Readme
View Catalog
Browse CD
Exit

MOTOROLA

As a registered user, you have access to the electronic catalogue for purchasing accessories and radios.

A.3 Accessories Aftermarket Division (AAD)

The Accessories Aftermarket Division is able to provide Motorola Solutions Branded accessories for all your radio needs. Contact Motorola Solutions after you have a KIT number, identified from the Motorola Online website and/or the ECAT catalog. You can contact them at: 800-422-4210.

Index

A

accessories	
connector assembly	4-1, 4-9
assembly	4-10
disassembly	4-9
exploded view	4-10
connector pins	4-8
headset	5-2, 5-27
installing	
dash mount	4-1
horn relay	4-3
light relay	4-3
remote mount	4-9
antenna	5-5
cable, see Cables, antenna	
installing	2-32, 5-21
motorcycle	5-2
mounting	2-32
site	2-32

B

base stations	1-11
black lead	2-30, 5-22, 5-27

C

cables	5-3, 5-4, 5-5, 5-24
accessory	4-1, 4-2, 5-22, 5-27
antenna	2-18
battery	4-9
connection	6-1, 7-1
diagrams	2-22, 5-21, 5-25
emergency	5-27
excess	5-24
ignition	4-9
microphone	5-2, 5-12
motorcycle control head	5-1, 5-9, 5-11, 5-22
motorcycle control head, installing	5-21
motorcycle transceiver	5-24
power	2-30, 5-22
remote mount	2-21
routing	5-22
speaker	5-2, 5-14, 5-21
configurations	
dash mount	1-6
motorcycle	1-11
multi control	1-11
remote mount	1-8
control head	2-26, 4-6, 4-8
cabling	2-21
diagrams	2-22, 2-23
multi	1-11
remote mount	1-8
control stations	1-11

D

dash mount	
accessories installations	4-1
configuration	1-6
installation examples	2-2
radio dimensions	1-1, 1-2, 1-3, 1-4
trunnion	2-19

E

emergency footswitch	4-1
emergency pushbutton	4-1
emergency switch	
installing	5-27
wiring	5-31
external alarm	
installing	5-27
see also Horn relay or Light relay	

F

footswitch, emergency	4-1
-----------------------	-----

H

horn relay	4-2, 4-3, 5-27, 5-31
------------	----------------------

I

ignition	
cable	4-9
wire	5-22
wire, for motorcycle	5-2
installation	
examples	2-2
important hints	5-4
order of	5-5

J

J2	4-7, 4-8
----	----------

L

leads	
black	2-30, 5-22, 5-27
light relay	4-2, 4-3, 5-27, 5-31
locking kit, installing	2-29

M

microphone	5-2, 5-4
hang-up clip, installing	5-14
hang-up clip, standard	2-38, 5-5, 5-9, 5-11
mounting	5-4
motorcycle	
antenna	5-2
configuration	1-11
control head cable	5-1

display unit	5-1	S	
external speaker	5-2	speaker	5-5
headset	5-2	cable, see Cables, speaker	
ignition wire	5-2	external	5-2
installation	5-3	fuel tank console installation	5-9, 5-10, 5-12
antenna	5-21	handlebar installation	5-8, 5-11, 5-12
cables	5-21	installing	5-7, 5-9, 5-14
cabling	5-24	mounting	2-35
control head	5-7		
emergency switch	5-27, 5-31	T	
external alarm	5-27	trunnion	2-22
fuel tank console	5-9, 5-10, 5-12	bracket for speaker	2-35
handlebar	5-8, 5-11	dash mount	2-19
headset	5-27	diagrams	2-22
horn/lights wiring	5-31	locking kit	2-29
microphone hang-up clip	5-14	motorcycle installation	5-25
speaker	5-7, 5-14	mounting bracket	2-19
transceiver	5-24, 5-26	remote mount	1-8, 2-21
universal mounting plate	5-6	transmission hump mounting	2-20
weather-resistant enclosure	5-23		
microphone	5-2	U	
transceiver	5-1	universal mounting plate	5-1, 5-3, 5-5
mounting configurations	2-18	installing	5-6
dash	1-6, 2-19		
motorcycle	1-11	V	
multi control	1-11	VIP	
remote	1-8, 2-21	connector	4-2, 6-2
mounting plate, universal	5-1, 5-3, 5-5	input connections	4-8
installing	5-6	output connections	4-7
mounting, antenna			
restrictions	2-32	W	
roof top	2-32	wiring diagrams	2-3
trunk lid	2-32		
multi control			
configuration	1-11		
O			
ordering replacement parts	A-1		
P			
parts, ordering replacement	A-1		
pin			
SW B+	4-3, 4-7, 4-8		
VIP in	4-8		
VIP out	4-3, 4-7		
pushbutton, emergency	4-1		
R			
relays			
horn	4-2, 4-3, 5-27, 5-31		
light	4-2, 4-3, 5-27, 5-31		
remote mount			
accessory installations	4-9		
cabling	2-21		
configuration	1-8		
control cable installation	2-26		
installation examples	2-2		
trunnion	2-21		
replacement parts, ordering	A-1		

Glossary

This glossary contains an alphabetical listing of terms and their definitions that are applicable to the ASTRO radio.

Term	Definition
band	Frequencies allowed for a specific purpose.
CPS	<i>See Customer Programming Software.</i>
Customer Programming Software	Software with a graphical user interface containing the feature set of an ASTRO radio.
default	A pre-defined set of parameters.
D.E.K	Direct Entry Keyboard.
digital	Refers to data that is stored or transmitted as a sequence of discrete symbols from a finite set; most commonly this means binary data represented using electronic or electromagnetic signals.
FCC	Federal Communications Commission.
firmware	Code executed by an embedded processor such as the Host or DSP in a subscriber radio. This type of code is typically resident in non-volatile memory and as such is more difficult to change than code executed from RAM.
frequency	Number of times a complete electromagnetic-wave cycle occurs in a fixed unit of time (usually one second).
GLONASS	GLObalnaya NAvigatsionnaya Sputnikovaya Sistema: The Russian Global Navigation satellite system, consisting of at least 24 operational satellites which fly in medium Earth orbit at an altitude of approximately 19,130 km. Each satellite circles the Earth slightly faster than twice a day. GLONASS provides Time and Location to anywhere on Earth, where there is an unobstructed line of sight to four or more GPS satellites. A GLONASS receiver triangulates its position using these satellites.
GNSS	Global Navigation Satellite System: Standard generic term for satellite navigation systems that provide geo-spatial positioning with global coverage. This term includes GPS, GLONASS, Galileo, Beidou and other regional systems. GNSS is a term used worldwide The advantage to having access to multiple satellites is accuracy, redundancy and availability at all times.

Term	Definition
GPS	Global Positioning System: U.S.A.'s Satellite based radio navigation system developed by the U.S. Department of Defense and operated by the U.S. Air Force, which consists of at least 24 operational satellites which fly in medium Earth orbit at an altitude of approximately 20,180 km. Each satellite circles the Earth twice a day. GPS provides Time and Location to anywhere on Earth, where there is an unobstructed line of sight to four or more GPS satellites. A GPS receiver triangulates its position using these satellites.
kHz	<i>See kilohertz.</i>
kilohertz	One thousand cycles per second. Used especially as a radio-frequency unit.
MCU	<i>See microcontroller unit.</i>
MHz	<i>See Megahertz.</i>
Megahertz	One million cycles per second. Used especially as a radio-frequency unit.
microcontroller unit	Also written as μC . A microprocessor that contains RAM and ROM components, as well as communications and programming components and peripherals.
PA	Power amplifier.
paging	One-way communication that alerts the receiver to retrieve a message.
PTT	<i>See Push-to-Talk.</i>
Publication Manual Revision	A publication that provides supplemental information for its parent publication before it is revised and reissued.
Push-to-Talk	The switch or button that causes the radio to transmit when pressed. When the PTT switch or button is released, the unit returns to standby or receive operation.
radio frequency	The portion of the electromagnetic spectrum between audio sound and infrared light (approximately 10 kHz to 10 GHz).
receiver	Electronic device that amplifies RF signals. A receiver separates the audio signal from the RF carrier, amplifies it, and converts it back to the original sound waves.
registers	Short-term data-storage circuits within the microcontroller unit or programmable logic IC.
RESET	Reset line: an input to the microcontroller that restarts execution.
RF	<i>See radio frequency.</i>
RX	Receive.

Term	Definition
signal	An electrically transmitted electromagnetic wave.
software	Computer programs, procedures, rules, documentation, and data pertaining to the operation of a system.
time-out timer	A timer that limits the length of a transmission.
TOT	<i>See time-out timer.</i>
transceiver	Transmitter-receiver. A device that both transmits and receives analog or digital signals. Also abbreviated as XCVR.
transmitter	Electronic equipment that generates and amplifies an RF carrier signal, modulates the signal, and then radiates it into space.
Triangulation	A method of determining the relative positions of points in space by measuring the distances, and sometimes angles, between those points and other reference points whose positions are known. Triangulation involves the use of trigonometry. It is commonly used in the navigation of vehicles, aircraft and boats, and is the method used in the Global Positioning System, in which the reference points are satellites.
TX	Transmit.
UHF	Ultra-High Frequency.
Universal Serial Bus	An external bus standard that supports data transfer rates of 12 Mbps.
USB	<i>See Universal Serial Bus.</i>
VHF	Very-High Frequency.
Waypoint	Geographic Coordinates of a specific location. It can also be an Intermediate point on a route or line of travel.
Wi-Fi	Wireless Data Transmission protocol 802.11.
XCVR	<i>See transceiver.</i>

Draft

Draft

Draft



MOTOROLA SOLUTIONS

Motorola Solutions, Inc.
1303 East Algonquin Road
Schaumburg, Illinois 60196 U.S.A.

MOTOROLA, MOTO, MOTOROLA SOLUTIONS and the Stylized M logo are trademarks or registered trademarks of Motorola Trademark Holdings, LLC and are used under license. All other trademarks are the property of their respective owners.
© 2016 Motorola Solutions, Inc. All rights reserved.
Oct 2016



MN003109A01_AA