



Mission Critical MC-EDGE Owner's Manual

MAY 2018 MN004736A01-A

© 2018 Motorola Solutions, Inc. All rights reserved

Contact Us

Motorola Solution Support Center

The Solution Support Center (SSC) is the primary Motorola Solutions support contact. Call:

1. Before any software reload.
2. To confirm troubleshooting results and analysis before removing and replacing a Field Replaceable Unit (FRU) and Field Replaceable Entity (FRE) to repair the system.

| For... | Phone |
|---------------------|---------------------|
| United States Calls | 800-221-7144 |
| International Calls | 302-444-9800 |

North America Parts Organization

For assistance in ordering replacement parts or identifying a part number, contact the Motorola Parts organization. Your first response when troubleshooting your system is to call the Motorola SSC.

| For... | Phone |
|--------------|--|
| Phone Orders | 800-422-4210 (US and Canada Orders) For help identifying an item or part number, select choice 3 from the menu. 302-444-9842 (International Orders) Includes help for identifying an item or part number and for translation as needed. |
| Fax Orders | 800-622-6210 (US and Canada Orders) |

Comments

Send questions and comments regarding user documentation to documentation@motorolasolutions.com.

Provide the following information when reporting a documentation error:

3. The document title and part number
4. The page number with the error
5. A description of the error

We welcome your feedback on this and other Motorola manuals. To take a short, confidential survey on Motorola Customer Documentation, go to docsurvey.motorolasolutions.com or scan the following QR code with your mobile device to access the survey.



Latest Manual Versions

You can verify the latest version of this manual at <https://businessonline.motorolasolutions.com>

Copyrights

The Motorola products described in this document might include copyrighted Motorola computer programs. Laws in the United States and other countries preserve for Motorola certain exclusive rights for copyrighted computer programs. Accordingly, any copyrighted Motorola computer programs contained in the Motorola products described in this document might not be copied or reproduced in any manner without the express written permission of Motorola.

© 2018 Motorola Solutions, Inc. All Rights Reserved

No part of this document might be reproduced, transmitted, stored in a retrieval system, or translated into any language or computer language, in any form or by any means, without the prior written permission of Motorola Solutions, Inc.

Furthermore, the purchase of Motorola products shall not be deemed to grant either directly or by implication, estoppel or otherwise, any license under the copyrights, patents or patent applications of Motorola, except for the normal non-exclusive, royalty-free license to use that arises by operation of law in the sale of a product.

Disclaimer

Note that certain features, facilities, and capabilities described in this document might not be applicable to or licensed for use on a particular system, or might be dependent upon the characteristics of a particular mobile subscriber unit or configuration of certain parameters. Please refer to your Motorola contact for further information.

Trademarks

MOTOROLA, MOTO, MOTOROLA SOLUTIONS, and the Stylized M Logo are trademarks or registered trademarks of Motorola Trademark Holdings, LLC and are used under license. All other trademarks are the property of their respective owners.

European Union (EU) Waste of Electrical and Electronic Equipment (WEEE) directive



The European Union's WEEE directive requires that products sold into EU countries must have the crossed out trash bin label on the product (or the package in some cases).

As defined by the WEEE directive, this cross-out trash bin label means that customers and end-users in EU countries should not dispose of electronic and electrical equipment or accessories in household waste.

Customers or end-users in EU countries should contact their local equipment supplier representative or service centre for information about the waste collection system in their country.

Document History

| Edition | Description | Date |
|---------------|--------------------|---------------|
| MN004736A01-A | <i>Release 1.0</i> | February 2018 |

FCC Information

This device complies with Part 15 of the FCC rules:

Operation is subjected of the following two conditions:

- (1) This device may not cause harmful interference, and (2) This device must accept any interference received, including interference that may cause undesired operation.

The user is cautioned that changes or modifications not expressly approved by the manufacturer could void the user's authority to operate the equipment.

FCC ID and IC of radio units:

| Radio | FCC ID | IC |
|------------------------|-------------|---------------|
| APX4000 VHF | AZ492FT1112 | 109U-92FT7112 |
| APX4000 UHF R1 | AZ492FT7113 | 109U-92FT7113 |
| APX4000 UHF R2 | AZ492FT7114 | 109U-92FT7114 |
| APX4000 700/800 | AZ492FT7115 | 109U-92FT7115 |
| APX4000 900 | AZ492FT7116 | 109U-92FT7116 |
| LTE Band 4 and Band 13 | N7NHL7588 | 2417C-HL7588 |
| LoRa Module | SQG-1001 | 3147A-1001 |

Important Safety Information

ATTENTION!

This radio is restricted to occupational use only to satisfy FCC RF energy exposure requirements.

Before using this product, read the RF energy awareness information and operating instructions in the Product Safety and RF Exposure booklet enclosed with your radio (Motorola Publication part number 6802988C84-B to ensure compliance with RF energy exposure limits.

Notice to Users (FCC and Industry Canada)

This device complies with Part 15 of the FCC rules and Industry Canada's license-exempt RSS's per the following conditions:

- This device may not cause harmful interference.
- This device must accept any interference received, including interference that may cause undesired operation.
- Changes or modifications made to this device, not expressly approved by Motorola, could void the authority of the user to operate this equipment.

“Under Industry Canada regulations, this radio transmitter may only operate using an antenna of a type and maximum (or lesser) gain approved for the transmitter by Industry Canada. To reduce potential radio interference to other users, the antenna type and its gain should be so chosen that the equivalent isotropically radiated power (e.i.r.p.) is not more than that necessary for successful communication”

This radio transmitter has been approved by Industry Canada to operate with Motorola-approved antenna with the maximum permissible gain and required antenna impedance for each antenna type indicated. Antenna types not included in this list, having a gain greater than the maximum gain indicated for that type, are strictly prohibited for use with this device.

This device complies with part 15 of the FCC Rules. Operation is subject to the following two conditions: (1) This device may not cause harmful interference, and (2) this device must accept any interference received, including interference that may cause undesired operation.

Industry Canada Compliance Statement

This Class B digital apparatus complies with Canadian ICES-003
Avis de conformité à la réglementation d'Industrie Canada
Cet appareil numérique de la classe B est conforme à la norme NMB-003 du Canada.

Contents

| | |
|---|-----------|
| Contact Us | 1 |
| Motorola Solution Support Center | 2 |
| North America Parts Organization | 2 |
| Comments | 2 |
| Latest Manual Versions | 2 |
| Copyrights | 2 |
| Disclaimer | 3 |
| Trademarks | 3 |
| European Union (EU) Waste of Electrical and Electronic Equipment (WEEE) directive | 3 |
| Document History | 4 |
| FCC Information | 5 |
| List of Figures | 11 |
| List of Tables | 15 |
| List of Procedures | 19 |
| Glossary | 23 |
| About MC-EDGE | 26 |
| What is Covered in This Manual | 26 |
| Helpful Background Information | 26 |
| Related Information | 26 |
| MC-EDGE Description | 27 |
| General Description | 29 |
| MC-EDGE Construction | 29 |
| Inputs and Outputs (I/Os) | 29 |
| Built-in Radios | 29 |
| LoRaWAN software upgradeable | 29 |
| LTE Verizon Bands Software Upgradeable | 30 |
| Communication Interfaces | 30 |
| Memory | 32 |
| CPU Real Time Clock (RTC) | 32 |
| MC-EDGE Components | 32 |
| MC-EDGE CPU | 35 |
| CPU Pushbutton | 36 |
| CPU LEDs | 36 |

| | |
|--|-----------|
| I/O Expansion Modules | 38 |
| MC-EDGE I/O Module LEDs | 40 |
| MC-EDGE Input Module I/O Arrangement | 43 |
| MC-EDGE Output Module I/O Arrangement | 43 |
| MC-EDGE Mixed I/O Module Arrangement | 44 |
| MC-EDGE I/O Module Terminal Block Connectors | 45 |
| MC-EDGE Hardware Test | 45 |
| MC-EDGE Antennas | 45 |
| MC-EDGE External Power Supply or Battery | 46 |
| MC-EDGE External Devices | 47 |
| Disposal of Components | 48 |
| MC-EDGE Installation | 49 |
| General | 49 |
| Mounting the MC-EDGE on a DIN Rail | 50 |
| Connecting an I/O Expansion Module to the MC-EDGE CPU | 52 |
| Connecting an I/O Expansion Module to another I/O Expansion Module | 54 |
| MC-EDGE Power and Ground Connections | 54 |
| Connecting the MC-EDGE to Power and Ground | 55 |
| Connecting MC-EDGE Data Cables | 58 |
| Connecting MC-EDGE I/Os | 58 |
| Bundling MC-EDGE Cables | 59 |
| Extracting Terminal Block Connectors from the I/O Module | 60 |
| Adding an Optional SD Card | 61 |
| Connecting Antennas to the MC-EDGE | 62 |
| Replacing the MC-EDGE DC Power Cable Fuse | 64 |
| Optional Auxiliary Radios and Installation Kits | 65 |
| MC-EDGE Supported Radio Types | 65 |
| Installation Kits for MC-EDGE Auxiliary Radios | 65 |
| MTM5200, MOTOTRBO XPR 5350 and APX 6500 Radio | 66 |
| Installation Kits | 66 |
| Installing the Mobile Radio Installation Kits | 66 |
| Configuration and Programming for the ASTRO APX 4000/APX 6500 Radio | 69 |
| Configuring the RTU Port Type for the APX 4000/APX 6500 Radio | 69 |
| RTU Port Type Advanced Parameter Configuration (for APX 4000/APX 6500 Radio) | 70 |
| IP Conversion Table for the APX 4000/APX 6500 Radio | 70 |
| APX 4000/APX 6500 Radio Programming using CPS | 71 |
| Connecting the APX 4000/APX 6500 Radio | 71 |
| Disassembling the APX 6500 Radio | 71 |
| Programming the APX Radio | 72 |

Contact Us

| | |
|--|------------|
| Infrastructure Configuration for the APX 6500 Radio | 73 |
| ASTRO APX 6500Li Options for MC-EDGE | 73 |
| Appendix A: MC-EDGE Specifications | 75 |
| MC-EDGE General Specifications | 75 |
| MC-EDGE Input Module Specifications | 80 |
| MC-EDGE Output Module Specifications | 82 |
| MC-EDGE Mixed I/O Module Specifications | 83 |
| MC-EDGE Regulatory Specifications | 84 |
| Appendix B: Cables and Adaptors | 85 |
| General | 85 |
| Connection to a Computer via RS232 | 85 |
| Connection to a Modem via RS232 | 86 |
| Connection to a PLC/RTU/FEP via RS232 | 87 |
| Connection to a PLC/RTU/FEP via RS485 | 89 |
| Connection to a Computer (Ethernet) | 90 |
| Connection to a Computer (USB OTG) | 90 |
| MC-EDGE CPU to MC-EDGE I/O Expansion Module Connection | 90 |
| Appendix C: MC-EDGE I/O References | 92 |
| Input /Mixed IO Module Block Diagram | 92 |
| Digital Output Circuit Diagrams | 93 |
| Analog Output Circuit Diagram | 93 |
| Output Module Block Diagram | 94 |
| Digital Output Circuit Diagrams | 96 |
| Analog Output Circuit Diagram | 96 |
| Appendix D: MC-EDGE External Connector Pin Outs | 100 |
| MC-EDGE CPU LAN Port Connector | 100 |
| MC-EDGE CPU RS232 Port Connector | 100 |
| MC-EDGE CPU RS485 Port Connector | 101 |
| MC-EDGE CPU I/O Connector | 101 |
| MC-EDGE CPU RJ50 Connector | 101 |
| MC-EDGE Input Module RJ50 Connector | 102 |
| MC-EDGE Input Module DI Connector | 103 |
| MC-EDGE Input Module AI Connector | 104 |
| MC-EDGE Output Module RJ50 Connector | 105 |
| MC-EDGE Output Module DO Connector | 106 |
| Appendix E: MC-EDGE Field Replacement Units | 110 |
| MC-EDGE Field Replacement Units and Parts | 110 |

List of Figures

- Figure 1 MC-EDGE Unit with Two I/O Expansion Modules with Covers. 15
- Figure 2 MC-EDGE Unit with two I/O Expansion Modules without Front Panel Covers. 16
- Figure 3 MC-EDGE CPU– General View with and without Side. 20
- Figure 4 MC-EDGE – Front View.. 20
- Figure 5 CPU Front Panel LEDs. 21
- Figure 6 MC-EDGE Input Expansion Module. 23
- Figure 7 MC-EDGE Output Expansion Module. 24
- Figure 8 MIXED IO Module. 24
- Figure 9 MC-EDGE Input Module I/O Arrangement 28
- Figure 10 MC-EDGE Output Module I/O Arrangement 29
- Figure 11 Dimensions of MC-EDGE Unit 35
- Figure 12 Plastic Tab in the MC-EDGE Unit 37
- Figure 13 Hooking the MC-EDGE Unit onto the DIN Rail 37
- Figure 14 Hooking the MC-EDGE Unit with I/O Expansion Module onto the DIN Rail 38
- Figure 15 MC-EDGE CPU Side Cover 38
- Figure 16 MC-EDGE CPU Connection to I/O Expansion Module. 39
- Figure 17 MC-EDGE I/O Expansion Module Connection to I/O Expansion Module. 40
- Figure 18 MC-EDGE DC Power Cable with Fuse. 41
- Figure 19 MC-EDGE Power and Ground Connections. 42
- Figure 20 MC-EDGE with I/O Expansion Power and Ground Connections. 42
- Figure 21 MC-EDGE I/O Module with TB Connector 44
- Figure 22 MC-EDGE Cables in Plastic Fastener 45
- Figure 23 TB Extractor on TB.. 46
- Figure 24 MC-EDGE CPU SD Cover 47
- Figure 25 Outdoors Installation of MC-EDGE Antennas. 48
- Figure 26 MTM5200, MOTOTRBO XPR 5350 and APX 6500 Radio Installation Kit Bracket Assembly 51
- Figure 27 MTM5200, MOTOTRBO XPR 5350 and APX 6500 Radio Installation Kit Bracket Assembly on DIN Rail 52
- Figure 28 APX 6500 Radio on DIN Rail 52
- Figure 29 XPR 5350 Radio on DIN Rail 53
- Figure 30 MTM5200 Radio on DIN Rail 53
- Figure 31 RTU Site Configuration for MDLC over ASTRO APX Radio – Advanced Parameters. 54
- Figure 32 MC-EDGE RJ45 RS232 connector 68
- Figure 33 Computer-RS232 Connectivity. 69
- Figure 34 RS232- Modem Connectivity. 70
- Figure 35 RS232-RTU/FEP Connectivity. 71

Contact Us

| | |
|---|----|
| Figure 36 RS232-PLC Connectivity. | 71 |
| Figure 37 RS485- PLC/RTU/FEP Connectivity. | 72 |
| Figure 38 B-6 MC-EDGE CPU to MC-EDGE I/O Expansion Module Connectivity. | 74 |
| Figure 39 12 DI/8 AI – Input module 7 DI/4 AI – Mixed IO module. | 75 |
| Figure 40 Digital Output Circuit Diagrams. | 76 |
| Figure 41 Analog Output Circuit Diagram.. | 76 |
| Figure 42 Output Module Block Diagram.. | 77 |
| Figure 43 Digital Output Circuit Diagrams. | 78 |
| Figure 44 Analog Output Circuit Diagram.. | 78 |
| Figure 45 MC-EDGE Input Module RJ50 Connector | 83 |

List of Procedures

| | |
|---|----|
| Procedure 1. Mounting the MC-EDGE on a DIN Rail | 38 |
| Procedure 2. Connecting an I/O Expansion Module to the MC-EDGE CPU | 39 |
| Procedure 3. Connecting an I/O Expansion Module to another I/O Expansion Module | 41 |
| Procedure 4. Connecting the MC-EDGE to Power and Ground | 42 |
| Procedure 5. Connecting the MC-EDGE Data Cables | 44 |
| Procedure 6. Connecting the MC-EDGE I/Os | 44 |
| Procedure 7. Bundling the MC-EDGE Cables | 45 |
| Procedure 8. Extracting the TB Connector from the I/O Module | 46 |
| Procedure 9. Adding an Optional SD Card | 47 |
| Procedure 10. Replacing the MC-EDGE DC Power Cable Fuse | 49 |
| Procedure 11. Installing the Mobile Radio Installation Kits | 52 |
| Procedure 12. Making the Bracket Smaller for MOTOTRBO XPR 5350 and MTM5200 Radios | 55 |
| Procedure 13. Mounting the Mobile Radio Power Supply for MC-EDGE | 56 |
| Procedure 14. Installing the APX 4000 Radio Installation Kit | 58 |
| Procedure 15. Installing the XPR 7350/80 Radio Installation Kit | 60 |
| Procedure 16. Configuring the MC-EDGE Port for the APX 4000/APX 6500 Radio | 63 |
| Procedure 17. Configuring the Advanced Parameters of the MC-EDGE Port for the ASTRO APX Radio | 64 |
| Procedure 18. Connecting the APX 4000/APX 6500 Radio to the CPS | 65 |
| Procedure 19. Disassembling the APX 4000 Radio | 65 |
| Procedure 20. Disassembling the APX 6500 Radio | 66 |
| Procedure 21. Programming the APX Radio Settings | 66 |
| Procedure 22. Configuring the MC-EDGE Port for the XPR 5350 MOTOTRBO Digital Radio | 68 |

| | |
|---|----|
| Procedure 23. Connecting the XPR 5350 MotoTRBO Digital Radio to the CPS | 70 |
| Procedure 24. Connecting the XPR 5350 MotoTRBO Digital Radio to the CPS | 70 |
| Procedure 25. Disassembling the XPR 5350 MOTOTRBO Digital Radio from the MC-EDGE Unit | 70 |
| Procedure 26. Programming the MOTOTRBO Digital Radio | 71 |
| Procedure 27. How to Configure the MC-EDGE Port for the MotoTrbo Connect Plus RadioPart 1: FIU Configuration to XRT Gateway | 72 |
| Procedure 28. How to Modify the Default Advanced Port Parameters for MotoTrbo Connect Plus Radio | 75 |
| Procedure 29. How to Connect the MotoTrbo Connect Plus Radio to the CPS | 77 |
| Procedure 30. How to Disassemble the MotoTrbo Connect Plus Radio from the MC-EDGE Metal Chassis | 78 |
| Procedure 31. Configuring the MC-EDGE Port for the XPR 5350 MOTOTRBO Digital Radio | 80 |
| Procedure 32. Configuring the Advanced Parameters of the MC-EDGE Port for the ASTRO APX Radio | 82 |
| Procedure 33. Configuring the MC-EDGE Port for the MTM5200 Radio | |

Glossary

| | |
|----------|--|
| ACE | Advanced Control Equipment |
| AI | Analog Input |
| AO | Analog Output |
| AWG | American Wire Gauge |
| DFM | Direct Frequency Modulation |
| DI | Digital (Discrete) Input |
| DO | Digital (Discrete) Output |
| DPSK | Differential Phase Shift Keying |
| EPP | Environmentally Preferred Product |
| ESD | Electrostatic Discharge |
| EU | European Union |
| FCC | Federal Communication Commission |
| FEP | Front End Processor |
| FPGA | Field Programmable Gate Array |
| FSK | Frequency Shift Keying |
| GND | Ground |
| GPS | Global Positioning Satellite |
| HW | Hardware |
| IC | Industry Canada |
| IEC | International Electrotechnical Commission |
| IO (I/O) | Input/Output |
| IP | Internet Protocol |
| LAN | Local Area Network |
| LED | Light Emitting Diode |
| NEMA | National Electrical Manufacturers Association (issues enclosure standards) |
| NC | Normally Closed |
| NO | Normally Open |
| OTG | On-The-Go (USB port as host or device) |
| PC | Personal Computer |
| PPS | Parts per Second |
| RAM | Random Access Memory |
| RF | Radio Frequency |
| RTU | Remote Terminal Unit |
| RX | Receive |
| SCADA | Supervisory Control and Data Acquisition |
| DRAM | Dynamic Random Access Memory |
| SW | Software |
| UHF | Ultra High Frequency |
| USB | Universal Serial Bus |
| VHF | Very High Frequency |
| WLAN | Wireless Local Area Netwo |

About MC-EDGE

This manual provides functional overview and procedures for the MC-EDGE.

What is Covered in This Manual

This manual contains the following sections:

Helpful Background Information

Motorola Solutions offers various courses designed to assist in learning about the system. For information, go to <http://www.motorolasolutions.com/training> to view the current course offerings and technology paths.

Related Information

Unless otherwise specified, the Motorola documents listed here are available from Motorola Online at <http://businessonline.motorolasolutions.com>. If you are new to Motorola Online, follow the on-screen instructions to sign up for an account. To access Public Safety LTE infrastructure manuals, select **Resource Center** → **Product Information** → **Manuals** → **MC-IOT** and select the appropriate release. The Resource Center also provides a Search function.

Additional informaton can be found in the below link

<https://code.motorolasolutions.com/iiot/MCEDGE>

Customers outside of the Americas can contact Motorola Solutions for the documentation listed here.

MC-EDGE Description

The IoT Mission Critical EDGE is a part of MSI mission critical IoT portfolio which provides an ecosystem for IoT developers, integrators and users to build out an IoT base solutions

The MC EDGE is an highly secured communication agnostic versatile IoT Gateway which uses LoRaWAN for Wireless Sensor Connectivity, extensive Physical I/O suite of interfaces.

The MC EDGE provides a suite of tools for edge analytics creation and data manipulation creation which varies from easy /intuitive Codeless web based tools to an highly suffictated C based SDK. The MC EDGE utilize an inherited LTE CAT- 4 and ASTRO (P25) connectivity capabilities

This solution is targeting two main markets: Mission critical with public safety oriented solution e.g. smart early warning, Safe city , Perimeter security etc. and critical infrastructure e.g. Smart water and electricity management

On the mission critical side, Highly secured mission critical IoT ecosystem will create a major differentiation points as well as migration path between LMR to PS LTE infrastructure. On the Critical infrastructure side, Communication agnosticism , Highly reliable Industrial GW will provide a market differentiation and superiority

Figure 1. MC-EDGE Unit with Two I/O Expansion Modules with Covers

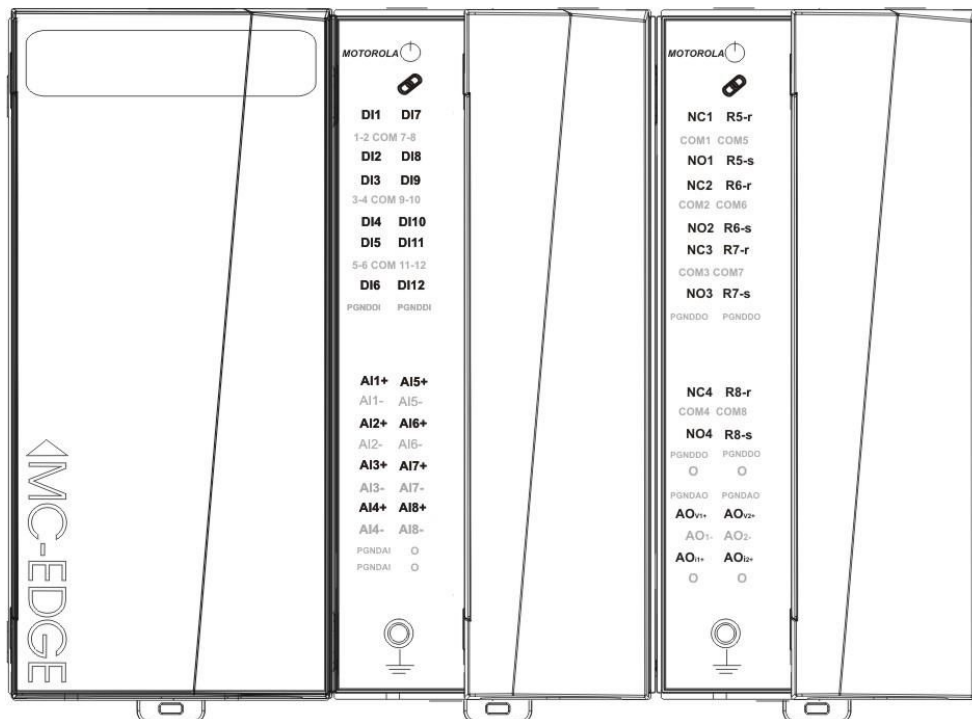
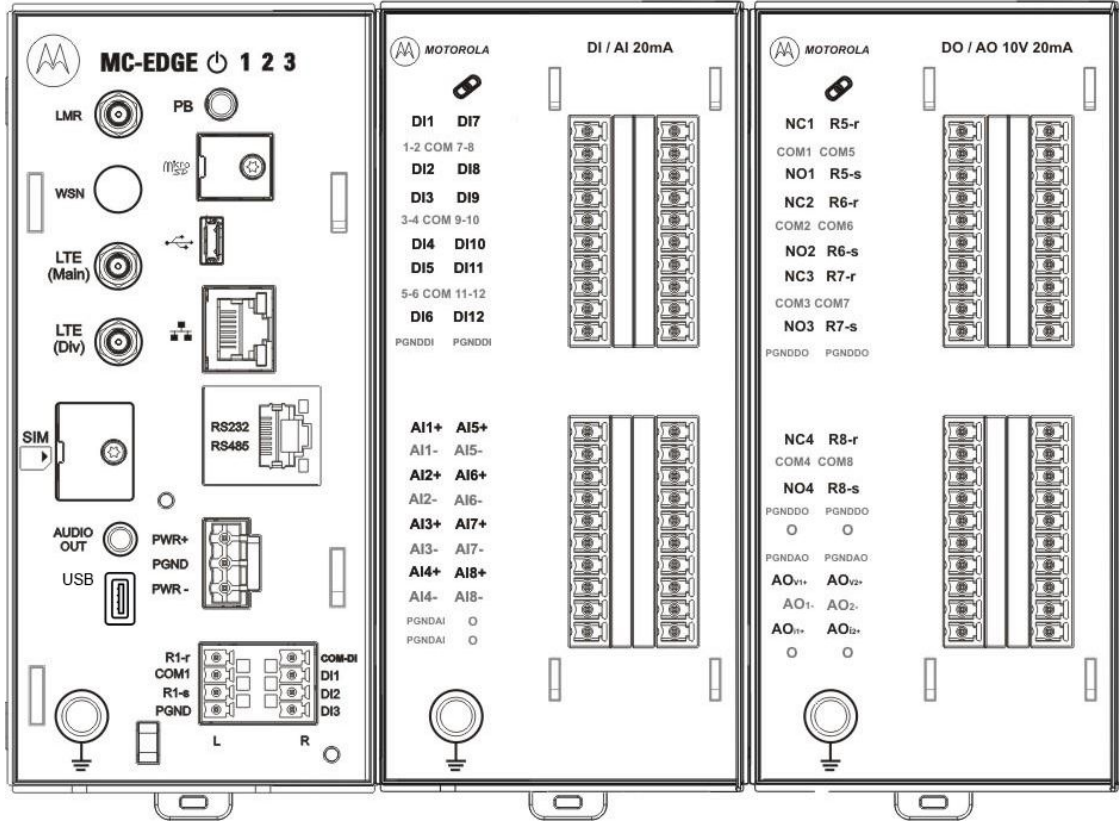

Figure 2. MC-EDGE Unit with two I/O Expansion Modules without Front Panel Covers



General Description

MC-EDGE Construction

Each MC-EDGE module is enclosed in a compact protective plastic housing. The CPU front panel provides easy access to connectors, ports and antennas. The I/O module front panel includes terminal block connectors for sensor/device wire connection.

The MC-EDGE is mounted on a DIN rail, in a customer-supplied plastic or metal enclosure.

For more information on mounting the unit and for enclosure requirements, see [MC-EDGE Installation](#).

For the unit dimensions and weight, see [Appendix A: MC-EDGE Specifications](#).

Inputs and Outputs (I/Os)

The MC-EDGE CPU module includes three Digital Inputs (DI) and one Digital Output (DO). In addition, up to two Input/Output (I/O) expansion modules can be added to the MC-EDGE CPU.

For details on the CPU and expansion module I/O specifications, see [Appendix A: MC-EDGE Specifications](#).

For details on the I/O expansion modules, see [I/O Expansion Modules](#).

Built-in Radios

The MC-EDGE unit includes the following set of communication radios:

LoRaWAN software upgradeable (Future option Hardware ready)

LoRa (Low power Radio) for customers that are seeking to deploy Internet of Things (IoT) applications fast in areas where large distances are involved, yet low capacity is needed. Wireless Sensors Network Class 1, 8 Channels at freq range of 902 to 928 MHz

LoRa has several benefits and characteristics as detailed below:

1. Long range enables solutions such as smart city applications.
2. Low power means long battery life for devices.
3. Low bandwidth makes it ideal for practical IoT deployments with less data and/or with data transmissions.
4. Low(er) connectivity costs.
5. Wireless, easy to set up and fast deployment.
6. Security: a layer of security for the network and one for the application with AES encryption knowing the concerns and security risks regarding IoT.
7. Fully bi-directional communication.
8. Open alliance and an open standard.

ASTRO P25

- 700/800
- VHF
- UHF R1
- UHF R2
- 900

LTE Verizon Bands Software Upgradeable

- LTE Air Prime HL7588
- B4 and B13 per 3GPP

Communication Interfaces

The MC-EDGE unit includes the following set of communication interfaces, for MDLC communication (between the FEP-RTU and RTU-RTU) and for non-MDLC communication (general communication with the FEP or RTU.)

1. USB1 Console port (device)
2. MDLC Communication via radio: ASTRO APX IV&D, LAN Ethernet 10/100 Mb/s port (ETH1)
3. Ethernet communication (MDLC and non-MDLC)
4. Non-MDLC MODBUS communication: SCADA Center slave, PLC master/slave
5. User defined communication: user application/user device

6. Configurable RS232 or RS485 serial port (SI1/UART1)
7. Cellular, General PPP connection (MDLC and non-MDLC)
Certified with the following modems: Sierra wireless -AirLINK FXT edge, Maxon
– Intelimax, Telit- Gate Tel GT-HE910-EUD
Other similar cellular modems can be used with MC-EDGE.



NOTICE: It is the user's responsibility to validate operation of any other modem.

8. Serial data modem communication: MDS SD 4710 modem (MDLC and non- MDLC)
9. External null modem communication: Westremo (MDLC and non-MDLC)
10. Communication via radio: TETRA MTM5200 radio (MDLC and non-MDLC)
11. Serial RS232 communication (MDLC and non-MDLC)
12. Serial RS485 multidrop communication (MDLC and non-MDLC)
13. Non-MDLC MODBUS communication: SCADA Center slave, PLC master/slave
14. Time synchronization via GPS
15. User defined communication: user application/user device
16. USB 2.0 Host port (USB4)
17. MDLC communication via radio: ASTRO APX IV&D. The following additional port can be added to the CPU on an optional plug-in board:
18. the following connector enables the connection of an MC-EDGE CPU to an MC-EDGE I/O expansion module. For information, see *MC-EDGE I/O Expansion Modules*.
19. RJ50 I/O expansion connector

Memory

The MC-EDGE unit includes the following memory:

1. 256 MB FLASH memory/at least 32 MB available for user data
2. 256 MB LPDDR DRAM/32 MB available for user data
3. Micro SD Card slot, up to 32 GB (card not supplied). In security systems used for CRYPTR module

CPU Real Time Clock (RTC)

The MC-EDGE CPU includes a low drift RTC. The date and time are retained using an on-board rechargeable lithium battery.

The CPU date and time can be set using the Web browser-based Easy Configurator tool or the STS. The CPU can also be synchronized with other RTUs in the system, using the system clock, or via GPS, using a PPS signal connected to the DCD line of the RS232 port.

MC-EDGE Components

The table below lists the components which can be included in the MC-EDGE.

Contact Us

Table 1. MC-EDGE Components

| Component | Function | Notes |
|--|--|--|
| CPU | Communicates with the control center, RTUs and other devices via the communication ports. | See <i>MC-EDGE CPU</i> . |
| 115/230 VAC to 12VDC power supply or 115/230 VAC to 24VDC power supply | Converts the main AC power source to the voltages required by the unit/radio. | See <i>MC-EDGE External Power Supply</i> . |
| I/O expansion module (up to two modules per CPU) | Matches between the MC-EDGE and signals of various types/levels. Interfaces between the MC-EDGE and the process signals. | See <i>MC-EDGE I/O Expansion Modules</i> . |
| Terminal blocks (TB) | Connects the signals to the I/O modules. | See <i>MC-EDGE I/O Expansion Modules</i> . |
| RS232 cable + adaptor (FKN0022) | Connects devices to RS232 port | See <i>Appendix B: Cables and Adaptors</i> . |
| RS485 cable (FKN0030 #CB000207A01) | Connects devices to RS485 port | See <i>Appendix B: Cables and Adaptors</i> |
| External DC power cable (FKN0033 #CB000170A01) | Connects CPU to external power supply | See <i>Appendix B: Cables and Adaptors</i> . |
| MTM5200 data cable (FKN0027) | Connects MTM5200 radio to CPU. | See <i>MC-EDGE Radio Types and Installation Kits</i> . |
| APX 6500 data cable (FKN0035) | Connects APX 6500 radio to CPU. | See <i>MC-EDGE Radio Types and Installation Kits</i> . |
| Ground cable (FKN0034 #30009286001) | Connects modules to ground. | |
| Expansion module cable (FHN0065 #30013144001) | Connects CPU to I/O expansion module, and I/O expansion module to I/O expansion module. | See <i>Appendix B: Cables and Adaptors</i> . |

MC-EDGE CPU

The MC-EDGE CPU controls all components attached to the unit. It includes a plug-in board with either APX4000 + LTE modem + LoWan or APX4000 + LTE modem

Figure 3 provides a general view of the MC-EDGE CPU.

Figure 3. MC-EDGE CPU– General View with and without Side Cover

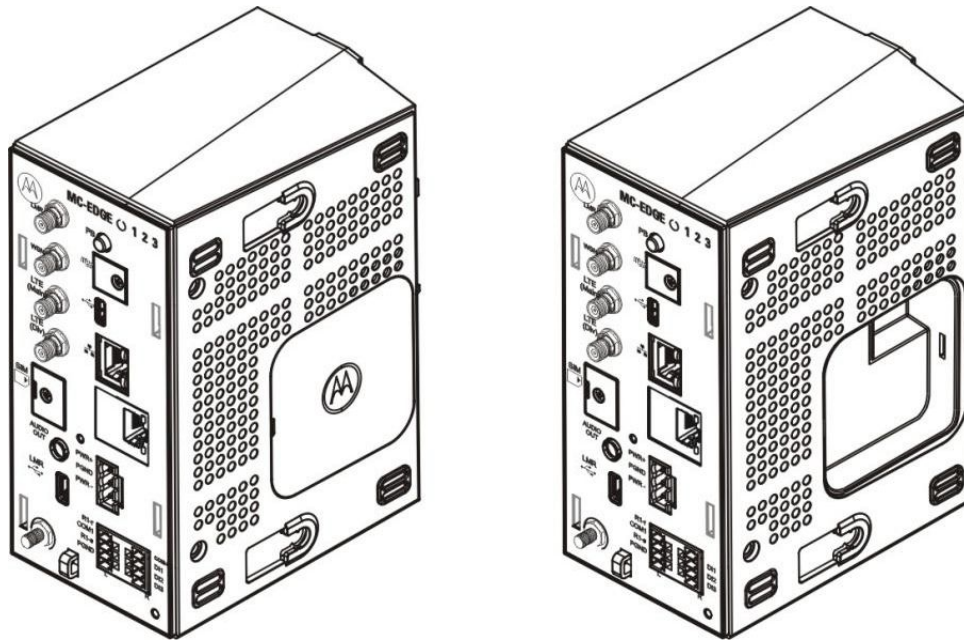

The MC-EDGE CPU panel includes status, user, power and communication port LEDs, a pushbutton, communication ports, antenna and ground connectors, and I/O connectors. Figure 4 shows the front view of the CPU.

Figure 4. MC-EDGE – Front View

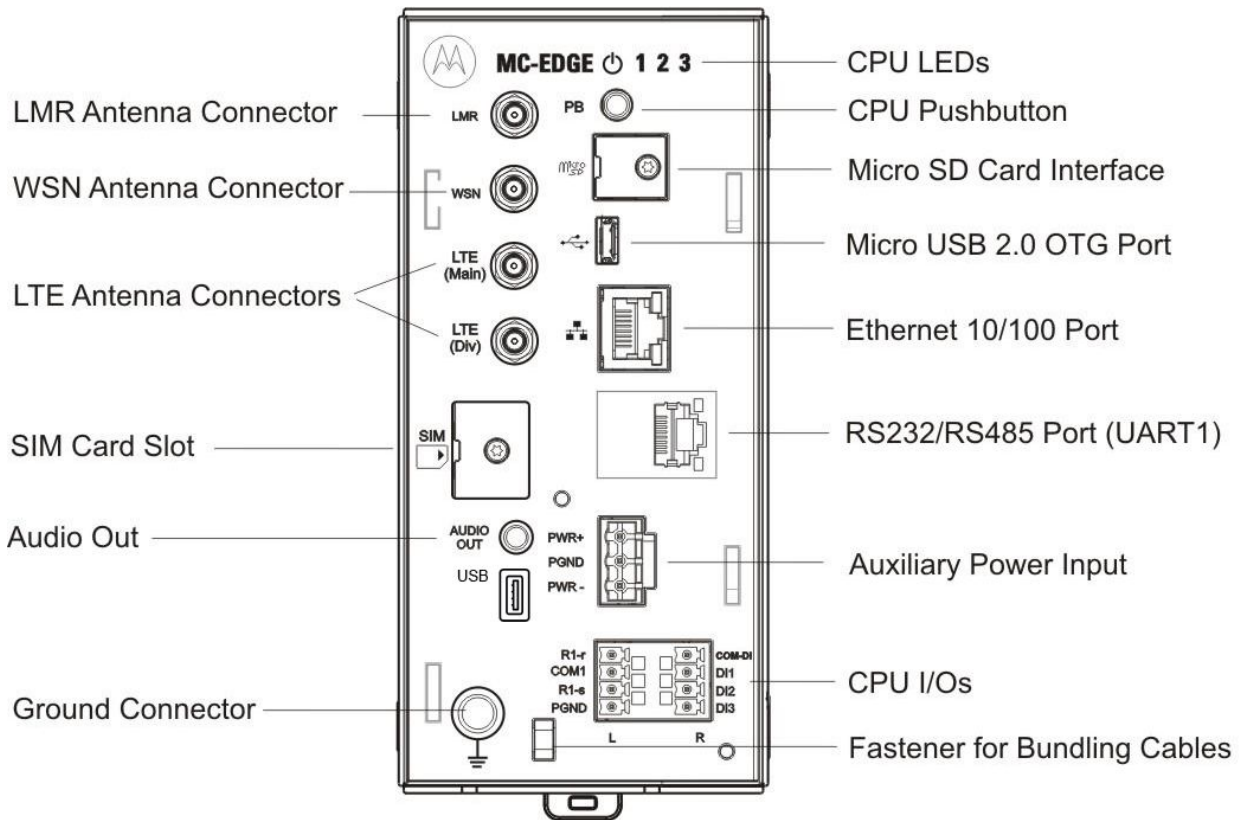

CPU Pushbutton

The pushbutton on the MC-EDGE CPU front panel has several functions:

1. LED activation – Hold the pushbutton pressed for one second to activate the LEDs for a preconfigured period of time.
2. Status indications - Press the pushbutton for three seconds to toggle between LED pages (see *MC-EDGE CPU LEDs*).
3. Note : Please be aware Press button more than 10 Sec cause restart to the RTU MicroControllers (CPU+I/O)

CPU LEDs

The MC-EDGE CPU front panel includes a power LED, status LEDs for onboard DIs/DO, and status LEDs on the communication ports. Some of the LEDs are single color (green) and some are bicolor LEDs (red or green). The LEDs are used to indicate various situations.

Figure 5. CPU Front Panel LEDs



By default, the CPU LEDs provide power, error, sleep mode, and DO status indications. Table 1-2 details the default display of the CPU LEDs (Page 0).

To see DI status indications, press the pushbutton for three seconds, to toggle to Page 1. Table 1-3 details the additional Page 1 CPU LEDs functionality. To toggle back to Page 0, press the pushbutton for again for three seconds.

Table 2. CPU LEDs – Page 0 (Default Display)

| LED Name | Description | Status |
|---|-----------------|---|
|  | Power/Error LED | <p>Off - Unit is powered off.</p> <p>Steady Green - Unit is powered on.</p> <p>Steady Red - Unit is powered on with errors in the Error Logger.</p> <p>Fast Blinking Green (once per second) - Unit is in boot state.</p> <p>Medium Blinking Red or Green (once every 10 seconds)</p> <ul style="list-style-type: none"> - Low input voltage fault state, when the processor is off. <p>Slow Blinking Red or Green (once every 30-90 seconds)</p> <ul style="list-style-type: none"> - Unit is in sleep mode. |
| 1 | DO Status | <p><u>Reset state</u>: The LED is off.</p> <p><u>Set state</u>: The LED is on (green).</p> |
| 2 | Not in Use | N/A |
| 3 | Not in Use | N/A |

Table 3. CPU LEDs - Page 1 (DI Display)

| LED Name | Description | Status |
|---|-----------------|---|
|  | Power/Error LED | <p>Fast Blinking Green (once in every 2 seconds) - Unit is powered on in Page 1.</p> <p>Fast Blinking Red (once in every 2 seconds) - Unit is powered on with errors in the Error Logger.</p> |
| 1 | DI1 Status | <p>Green - A powered-on DI is On (high from 6-30V).</p> <p>Off - DI is Off (low 0–3 V).</p> |
| 2 | DI2 Status | <p>Green - A powered-on DI is On (high from 6-30V).</p> <p>Off - DI is Off (low 0–3 V).</p> |
| 3 | DI3 Status | <p>Green - A powered-on DI is On (high from 6-30V).</p> <p>Off - DI is Off (low 0–3 V).</p> |

Table 4. CPU Port LEDs

| Description | Status |
|-------------|--------|
|-------------|--------|

Contact Us

| | |
|-------------------------------|--|
| Ethernet 10/100 port LED | Green - Unit is connected to Ethernet. Green Blinking – Transmitting/receiving data |
| RS232/RS485 Port (UART1) LEDs | Green - Transmitting data Yellow - Receiving data |

I/O Expansion Modules

The MC-EDGE RTU can include up to I/O expansion modules. Four I/O module types are available:

1. Input module with mixed 12 DI and 8 AI 4-20mA
2. Input module with mixed 12 DI and 8 AI 0-5V
3. Output module with mixed 8 DO and 2 AO
4. Mixed IO module with 7 DI 6DO 4 AI 1 AO

The I/O modules are attached in a daisy-chain, with the first module attached to the CPU, and the next module attached to the first. A cable with two RJ50 connectors is used to connect the I/O module to the CPU or to another I/O module.

Each I/O module includes a power LED, a link LED (future use), individual I/O status LEDs, and an array of I/O connectors.

An I/O module can only be added/removed to/from an MC-EDGE unit when the power to the unit is off.

For detailed specifications of each I/O expansion module, see *Appendix A: General Specifications*.

Figure 6 depicts the Input expansion module without a cover and with a cover.

Figure 7 depicts the Output expansion module without a cover and with a cover.

Figure 8 depicts the Mixed I/O expansion module without a cover and with a cover

Figure 6. MC-EDGE Input Expansion Module

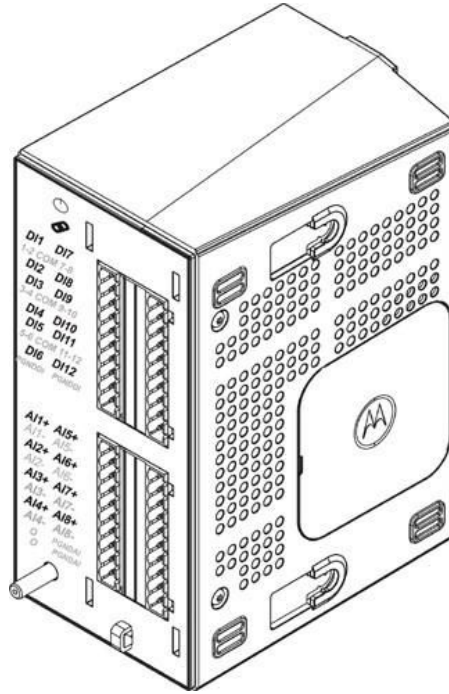

General View

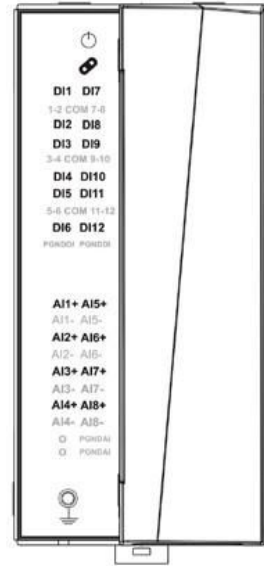

Front View with Cover

Figure 7. MC-EDGE Output Expansion Module

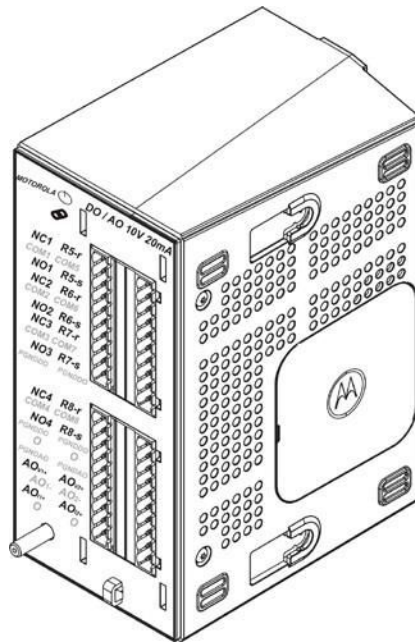

General View

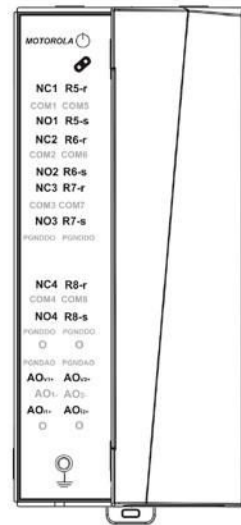

Front View with Cover

Figure 8. 1-8 MIXED IO Module

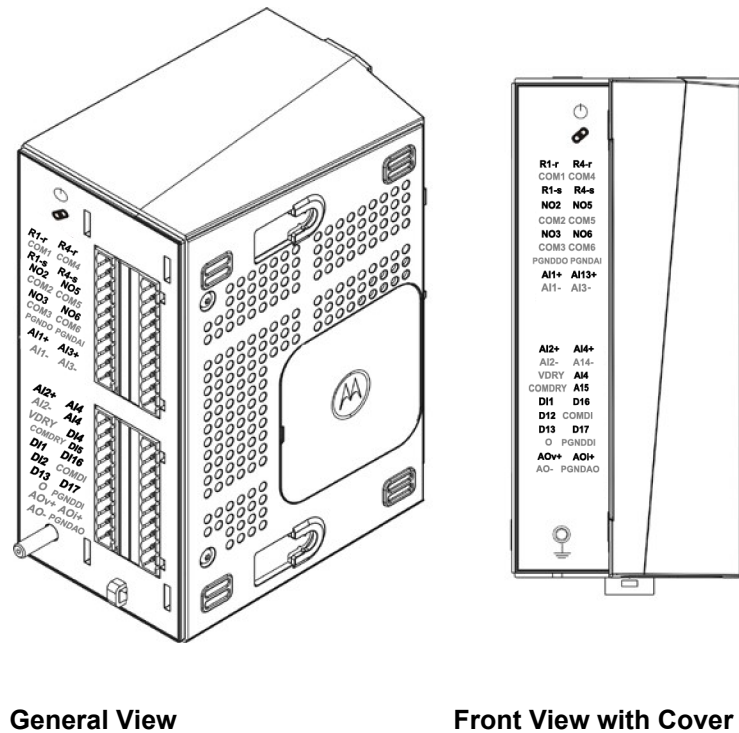



MC-EDGE I/O Module LEDs

The I/O module LEDs are used to indicate module and I/O status. LED indications are arranged according to the pins in the connectors.

The Input module has one LED indication for each I/O. The Output module has two LED indications for each DO and one LED indication for each AO. See *Table 1-5*, *Table 1-6*, and *Table 1-7* for LED functionality of the modules.

The Mixed IO Module has Two LED indications for each DO and one LED indication for AO one LED indication for each input.

Table 5. Input Module LEDs

| LED Name | Description | Status |
|---|-------------|--|
|  | Power LED | Off – I/O module is powered off. Steady Green – I/O module is powered on. Fast Blinking Green (once per second) – I/O module is in boot state. |
|  | Link LED | Green – Proper Communication with Main CPU Red - No Communication with Main CPU. |
| DI1-DI12 | DI Status | Green - A powered-on DI is On (high from 6-30V). Off - DI is Off (low 0-3V). |
| AI1 - AI8 | AI Status | Green - AI value is in range (0-20mA, 4-20mA, or 0-5V). |

| | | |
|--|--|---------------------------------|
| | | Red - AI value is not in range. |
|--|--|---------------------------------|

Table 6. Output Module LEDs







| LED Name | Description | Status |
|---|--------------------|---|
|  | Power LED | Off – I/O module is powered off. Steady Green – I/O module is powered on. Fast Blinking Green (once per second) – I/O module is in boot state. |
|  | Link LED | Green – Proper Communication with Main CPU Red - No Communication with Main CPU. |
| NC1/NO1 - NC4/NO4 | EE DO Relay Status | <u>Default (non-operated) state:</u> The NC# LED is on (green). The NO# LED is off. The NC# (normally closed) pin is connected to the COM# pin. <u>Operate state:</u> The NC# LED is off. The NO# LED is on. The NO# (normally open) pin is connected to the COM# pin. |
| R1-r/R1-s - R8-r/r8-s | ML DO Relay Status | <u>Reset state:</u> The R#_r LED is on (green). The R#_s LED is off. The R#_r pin is connected to the COM# pin. <u>Set state:</u> The R#_r LED is off. The R#_s LED is on (green). The R#_s pin is connected to the COM# pin.  NOTICE: The ML relay can be configured via software to preserve or reset the DO status at startup. |
| AOv1/2, AOi1/2 | AO Status | Green - AO is active. Off - AO is not active. |

Table 7 Mixed IO Module LEDs

| LED Name | Description | Status |
|---|-------------|--|
|  | Power LED | Off – I/O module is powered off. Steady Green – I/O module is powered on. Fast Blinking Green (once per second) – I/O module is in boot state. |
|  | Link LED | Green – Proper Communication with Main CPU Red - No Communication with Main CPU. |

Contact Us

| | | |
|--|-----------------------------------|--|
| <p>NC2/NO2 – NC3/NO3 NC5/NO5 NC6/NO6</p> | <p>EE DO Relay Status</p> | <p><u>Default (non-operated) state:</u> The NC# LED is on (green). The NO# LED is off. The NC# (normally closed) pin is connected to the COM# pin.</p> <p><u>Operate state:</u> The NC# LED is off. The NO# LED is on. The NO# (normally open) pin is connected to the COM# pin.</p> |
| <p>R1-r/R1-s –R4-r/r4- s</p> | <p>ML DO Relay Status</p> | <p><u>Reset state:</u> The R#_r LED is on (green). The R#_s LED is off. The R#_r pin is connected to the COM# pin.</p> <p><u>Set state:</u> The R#_r LED is off. The R#_s LED is on (green). The R#_s pin is connected to the COM# pin.</p> <p> NOTICE: The ML relay can be configured via software to preserve or reset the DO status at startup.</p> |
| <p>DI1-DI12</p> | <p>DI Status</p> | <p>Green - A powered-on DI is On (high from 6-30V). Off - DI is Off (low 0-3V).</p> |
| <p>AI1 – AI4</p> | <p>AI Status</p> | <p>Green - AI value is in range (0-20mA, 4-20mA, or 0-5V). Red - AI value is not in range.</p> |

MC-EDGE Input Module I/O Arrangement

In the Input module, the upper 20 pins belong to the 12 Digital Inputs (DI). DIs are arranged in groups of three pins, e.g. DI1:COM1-2:DI2. Each group is isolated one from the other and has its own COM pin. PGNDDI pins must be connected to protected ground (ground screw).

The lower 20 pins of the Input module belong to the 8 Analog Inputs (AI). AIs are arranged in couples with positive and negative pins. Each AI channel is isolated from the other and isolated from the logic circuit. PGNDAI pins must be connected to protected ground (ground screw). AIs are calibrated in the factory.

Figure 9. MC-EDGE Input Module I/O Arrangement

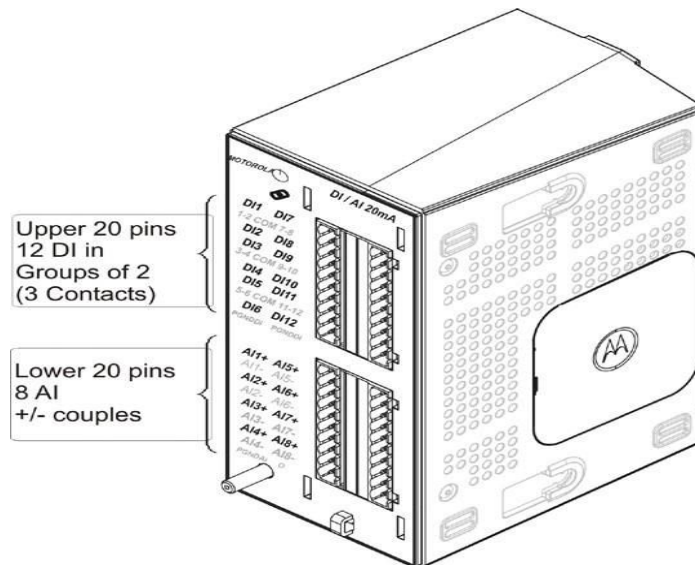

For details on AI calibration, see the "MC-EDGE Hardware Test" section of the *MC-EDGE Easy Configurator User Guide*.

MC-EDGE Output Module I/O Arrangement

In the Output module, the upper pins belong to the 8 Digital Outputs. The first four DOs are Electrically Energized (EE). The EE DOs are arranged in groups of three pins per relay, e.g. NC1:COM1:NO1. The second four DOs are Magnetically Latched (ML). The ML DOs are arranged in groups of three pins per relay, e.g. R5-r:COM5:R5-s. Each group is isolated from the other and has its own PGNDDO pin. PGNDDO pins must be connected to protected ground (ground screw).

The lower pins of the Output module belong to the 2 Analog Outputs (AO). The AOs are arranged in groups of three pins, e.g. AOv1+:AO1-:AOi1+.

5. AOv1+:AO1- and AOv2+:AO2- are Voltage output pins.
6. AOi1+:AO1- and AOi2+:AO2- are current output pins.

The PGNDAO pins must be connected to protected ground (ground screw). The AOs are calibrated in the factory.

Figure 10. MC-EDGE Output Module I/O Arrangement

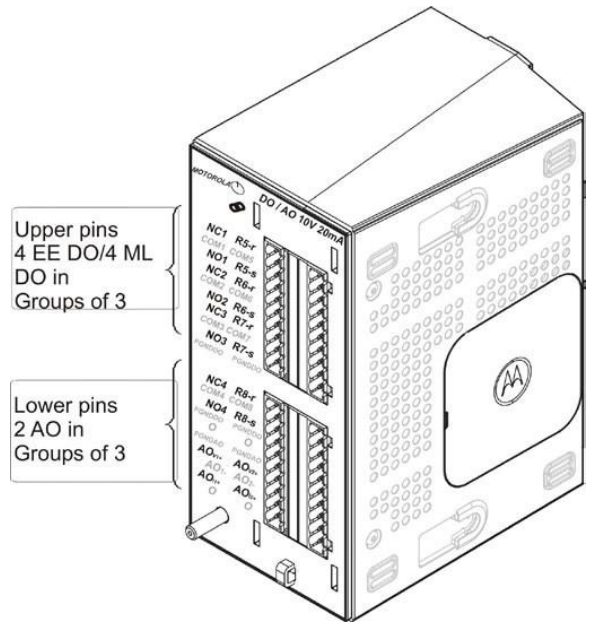

For details on AO calibration, see "MC-EDGE Hardware Test" section of the *MC-EDGE Easy Configurator User Guide*.

For pin table details and I/O module block diagrams, see *Appendix C: MC-EDGE I/O References*.

MC-EDGE Mixed I/O Module Arrangement

In the Mixed module the upper pins belong to the 6 Digital outputs

DO's 1 & 4 are Magnetically Latched (ML). The ML DOs are arranged in groups of three pins per relay, e.g. R4-r:COM4:R4-s. Each group is isolated from the other and has its own PGND pin. PGND pins must be connected to protected ground (ground screw).

DO's 2-3-5-6 are Electrically Energized (EE) .

The EE DOs are arranged in groups of two pins per relay, e.g. COM2:NO2

There are 4 AI inputs located in the Middle of the module AIx+ - AIx-

The 1 AO voltage or current are located on the bottom of the module AOV+, AOI+, AO-

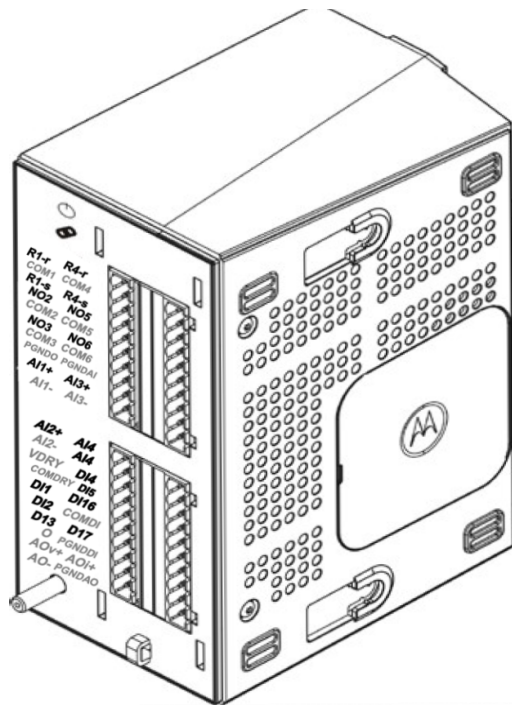

MC-EDGE I/O Module Terminal Block Connectors

Each I/O module is equipped with a set of two terminal block (TB) connectors (5 mm pitch), with 20 pins each. Each TB connector has a fixed female side on the module and two male plugs for the sensor/device wire connection. The TB male side (#FHN0061A) is screw type for up to 2mm (12 AWG) wire. See *MC-EDGE Installation* chapter for details on connecting MC-EDGE I/Os.

A TB extractor tool (FKN0024A) is provided for easy removal of TBs. See *MC-EDGE Installation* chapter for details on extracting the TB connectors from the module.

MC-EDGE Hardware Test

The MC-EDGE unit can be tested using the Web browser-based MC-EDGE Easy Configurator tool. The tests include retrieving general information, performing I/O operations, setting power management profiles, testing LEDs, and testing service mode. In addition, the user 'C' application can call system services to retrieve information from the main board and to set the main board DO.

For more information, see "MC-EDGE Hardware Test" section of the *MC-EDGE Easy Configurator User Guide*.

MC-EDGE Antennas

Only the approved antenna listed below can be used with the MC-EDGE.

1. BMLPVMBLTENGP-VP: MLPV Low-Profile Vertical Antenna for 698-960 MHz, 1710-2700 MHz
2. MWV1365S: WIDEBAND VHF NO TUNE ANTENNA for 132-174 MHz
3. MWU4002S: Wideband No Tune UHF ANT Antennas for 380-520 MHz
4. MC-EDGE Models, Options and Accessories

MC-EDGE Ordering available options

The following MC-EDGE models and options are available:

1. F0016A - MC-EDGE CPU module
2. F0043A - ACE1100 FEP (VA00154AA)
3. VA00007AA /FLN0050A - 12DI/8AI 20mA module
4. VA00047AA /FLN0051A - 12DI/8AI 5V module
5. VA00008AA /FLN0052A - 8DO/2AO 10V, 20mA module
6. VA00598AA/FLN0116A - 7 DI 6DO 4 AI 1 AO module
7. FLN0100A – APX 6500Li Installation Kit
8. VA00710AA - APX4000 VHF FOR MC-EDGE
9. VA007111AA - APX4000 UHF R1 FOR MC-EDGE
10. VA00712AA - APX4000 UHF R2 FOR MC-EDGE
11. VA00713AA - APX4000 700/800 FOR MC-EDGE
12. VA00714AA - APX4000 900 FOR MC-EDGE

13. VA00715AA - LTE VERIZON USA/CANADA MODEM FOR MC-EDGE
14. VA00726AA - LORA 902 - 928 MHZ USA/CANADA MODEM FOR MC-EDGE (Future Option)
15. MC-EDGE I/O configuration available options

The following configurations are available for MC-EDGE systems:

1. MC-EDGE CPU only (F0016A)
2. MC-EDGE CPU + 12DI/8AI (20mA or 5V) module
3. MC-EDGE CPU + two 12DI/8AI (20mA or 5V) modules
4. MC-EDGE CPU + 12DI/8AI (20mA or 5V) module+ 8DO/2AO module
5. MC-EDGE CPU + 8DO/2AO module
6. MC-EDGE CPU + two 8DO/2AO modules
7. MC-EDGE CPU + Mixed IO module
8. MC-EDGE CPU + two Mixed IO modules
9. MC-EDGE CPU + Mixed IO module+2DI/8AI (20mA or 5V) module
10. MC-EDGE CPU + Mixed IO module+8DO/2AO module

MC-EDGE I/O accessories options

The following accessories are available for MC-EDGE systems:

1. VA00015AA/FHN0054A - DIN Rail 26 CM
2. FHN0057A - DIN Rail Stopper
3. FHN0058A - CPU Cable Cover
4. FHN0059A - I/O Module Cable Cover
5. FHN0060A - SD Cover
6. FHN0061A - Terminal Block Male 10 PIN 5MM
7. FHN0062A - Terminal Block Male 3 PIN 5 MM
8. FHN0063A - Terminal Block Male 2 PIN 5 MM
9. FHN0064A - Terminal Block Male 4 PIN 3.5MM
10. FHN0065 - RJ50 I/O Module Cable
11. FKN0022 - RS232 Data Cable Adaptor
12. VA00153AA/FKN0024A - Terminal Block Connector Extractor
13. FKN0030 - RS485 Port 120 OHM Termination Cable
14. VA00155AA/FKN0033 - DC Power Cable

The full list of MC-EDGE options and accessories are listed in the MC-EDGE System Planner.

MC-EDGE External Power Supply or Battery

Contact Us

The MC-EDGE can be ordered with an external AC/DC power supply. These are drop ship items that are provided with the MC-EDGE unit. The following power supplies are available:

1. Lambda Electronics DPP120-12-1 AC power supply 12VDC/10A, 120W, 90-264VAC (mounted on DIN rail) DC output
2. Artesyn ADN5-24-1PM-C AC power supply 24VDC/5A, 120W, 85-264VAC (mounted on DIN rail) DC output, Limited temp. -25 - +70

Alternatively, a customer-supplied AC/DC power supply or DC power source (DC/DC converter or battery) can be used. See the MC-EDGE input voltage and power consumption specifications in *Appendix A: MC-EDGE Specifications.*)

MC-EDGE External Devices

The following external devices have been tested and certified as compatible with the MC-EDGE:

1. Serial data modem (Data radio): MDS SD Series
2. Cellular/general PPP: Sierra wireless - AirLink FXT edge, Maxson – intelimax, Telit-Gate Tel GT-HE910-EUD
3. External/Null modem: Westremo TD36
4. Astro (IV&D) radio: APX 4000, APX 6500
5. MOTOTRBO radio: XPR 5350/80, XPR 7350/80
6. SanDisk Cruzer Blade (SDZ50-032G) and SanDisk Cruzer Blade (SDZ50-004G)
7. GPS Receiver: NMEA-0183

Other similar devices can be used with MC-EDGE.



NOTICE: It is the user's responsibility to validate compatibility of any other devices.



CAUTION: Do not remove a storage device from the USB Host port while the MC-EDGE unit is in sleep mode.



MISES EN GARDE: Ne retirez pas un périphérique de stockage du port hôte USB alors que l'unité MC-EDGE est en mode veille

Disposal of Components

All components of the MC-EDGE should be properly disposed of, in accordance with local regulatory standards and laws.

MC-EDGE Installation

General

The MC-EDGE is shipped from the factory ready for mounting on a wall or in a customer's enclosure.



WARNING:

Installation of the MC-EDGE should be done only by authorized and qualified service personnel in accordance with the US National Electrical Code. Only UL Listed parts and components will be used for installation. Use UL Listed devices having an environmental rating equal to or better than the enclosure rating to close all unfilled openings.

If the installation involves high-voltage connections, technicians must be specifically qualified to handle high voltage.



AVERTISSEMENT:

L'installation de l'unité MC-EDGE doit être effectuée exclusivement par le personnel de service autorisé et qualifié, conformément au code national de l'électricité des États-Unis. Seuls des pièces et composants identifiés UL seront utilisés pour l'installation. Utiliser des appareils identifiés UL dont l'indice de protection environnementale est égal ou supérieur à l'indice de protection du boîtier pour fermer toutes les ouvertures non couvertes.

Dans les cas où l'installation comporterait des connexions haute tension, les techniciens doivent être spécialement qualifiés pour travailler avec cette haute tension.

INSTALLATION CODES

This device must be installed according to the latest version of the country's national electrical codes. For North America, equipment must be installed in accordance to the applicable requirements in the US National Electrical Code and the Canadian Electrical Code.

INTERCONNECTION OF UNITS

Cables for connecting RS232 and Ethernet Interfaces to the unit must be UL-certified type DP-1 or DP-2. (Note-when residing in a non LPS circuit.)

Do not remove the SD card when the unit is energized.

OVERCURRENT PROTECTION

A readily accessible 2-pole Listed branch circuit overcurrent protective device rated 20 A must be incorporated in the building wiring.

CODES D'INSTALLATION

Cet appareil doit être installé conformément à la plus récente version des codes nationaux de l'électricité du pays. En Amérique du Nord, l'équipement doit être installé conformément aux exigences en vigueur dans le code national de l'électricité des États-Unis et le Code canadien de l'électricité.

INTERCONNEXION DES UNITÉS

Les câbles pour la connexion des interfaces RS232 et Ethernet à l'unité doivent être certifiés UL type DP-1 ou DP-2. (Remarque-dans un circuit non LPS.)

Ne pas retirer la carte SD lorsque l'unité est sous tension.

PROTECTION CONTRE LA SURINTENSITÉ

Un appareil de protection contre les surintensités dans le circuit de dérivation, de 20 A et à deux pôles, doit être intégré dans le câblage de l'édifice.

 **CAUTION:** If the MC-EDGE is subject to high levels of shock or vibration, you must take suitable measures to reduce the acceleration or amplitude. We recommend that you install the MC-EDGE on vibration-damping materials (for example, rubber-metal anti-vibration mountings).

Ethernet LAN, RS485 and I/O cables can be a maximum length of 100m.

 **MISES EN GARDE:** Si le module MC-EDGE est soumis à des niveaux élevés de chocs ou de vibrations, vous devez prendre des mesures adéquates pour en réduire l'accélération ou l'amplitude. Nous vous recommandons d'installer le module MC-EDGE sur une surface qui atténue les vibrations (sur un support de métal et caoutchouc antivibration, par exemple).

Câbles Ethernet LAN, RS485 et E/S peuvent avoir un maximum de 100 mètres.

Mounting the MC-EDGE on a DIN Rail

The MC-EDGE is mounted on a customer-supplied 35 cm DIN rail, which can be installed either on a wall or in a plastic or metal enclosure.

Figure 11 shows the dimensions of the unit. Allow an additional 5 cm (2") (in W, H) and 10 cm (4") (in D) around the unit. When mounted in an enclosure, allow an additional 6 cm (2.4") (in W, H) and 7 cm (2.75") (in D) around the enclosure.

Figure 11. Dimensions of MC-EDGE Unit

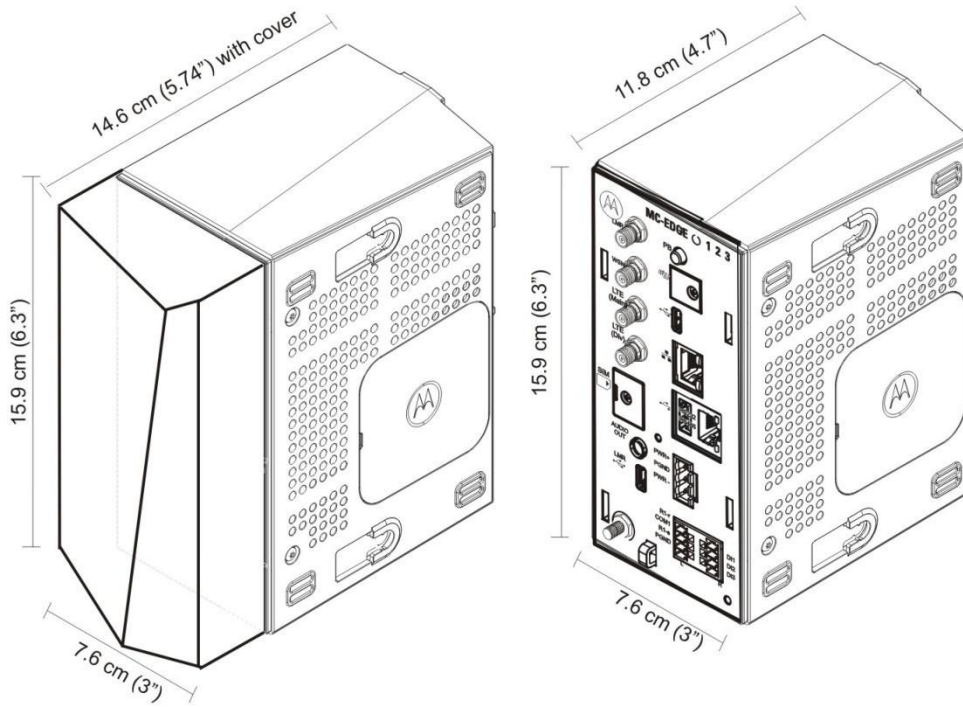

Prerequisite: Before performing this procedure, secure the DIN rail using at least three M5 screws and three M5 washers.

Prerequisite: Connect the MC-EDGE CPU to any I/O expansion modules before mounting on the DIN rail. See Procedure 2-2.

Contact Us

Procedure 1. Mounting the MC-EDGE on a DIN Rail

1. Slide the supplied plastic tab at the back of the unit all the way down to the bottom of the unit. See Figure 12. If the MC-EDGE unit includes one or more I/O expansion modules, repeat this step for all I/O expansion modules.

Figure 12. Plastic Tab in the MC-EDGE Unit

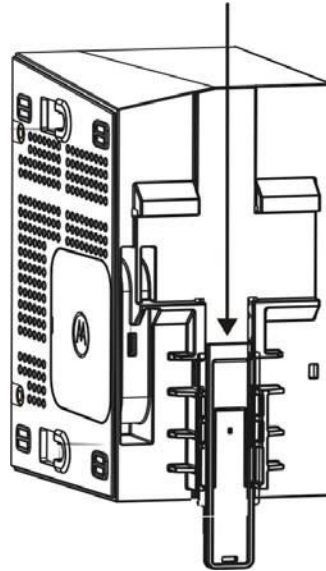

2. Lift the MC-EDGE unit and hang onto the DIN rail, using the hooks in the back of the unit. See Figure 13.

Figure 13. Hooking the MC-EDGE Unit onto the DIN Rail

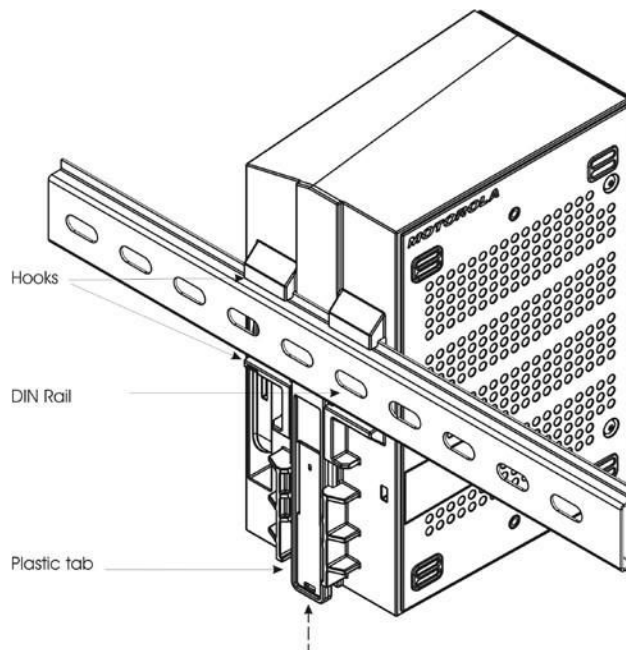

3. Slide the plastic tab upwards, until it locks against the DIN rail. See Figure 13. If the MC-EDGE unit includes one or more I/O expansion modules, repeat this step for all

I/O expansion modules. See Figure 14.

Figure 14. Hooking the MC-EDGE Unit with I/O Expansion Module onto the DIN Rail

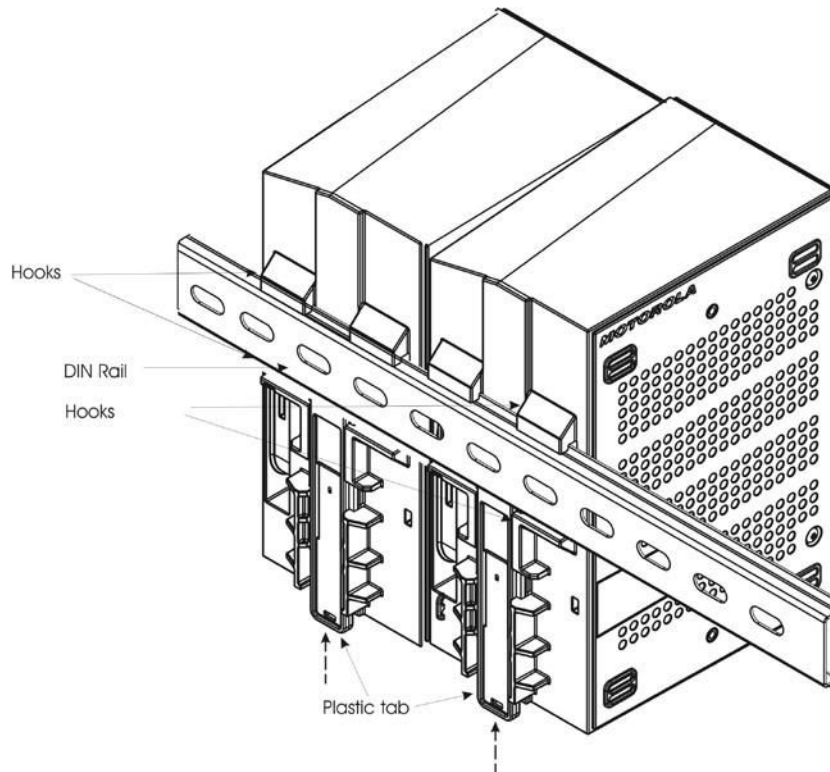

4. (Optional) Clip two stoppers onto the DIN rail, one to the left and one to the right of the unit to keep the unit in place. Tighten the built in screws.
5. Connect the data cables to the unit. See *Connecting MC-EDGE Data Cables*.
6. Connect the I/O sensors. See *Connecting MC-EDGE I/Os*.
7. Bundle the cables and attach them to the fastener on the module. See *Bundling MC-EDGE Cables*.
8. Insert the four legs of the front cover into the matching grooves on the front of each module and slide the cover down.

Connecting an I/O Expansion Module to the MC-EDGE CPU

The I/O expansion modules must be connected to the MC-EDGE CPU before mounting the unit on the DIN rail. Follow the procedure below to connect an I/O expansion module to the MC-EDGE CPU.

Procedure 2. Connecting an I/O Expansion Module to the MC-EDGE CPU

1. Insert a narrow tool (e.g. flat screwdriver) into the groove of the side cover on the right side of the MC-EDGE CPU and remove the cover.

Contact Us

Figure 15. MC-EDGE CPU Side Cover

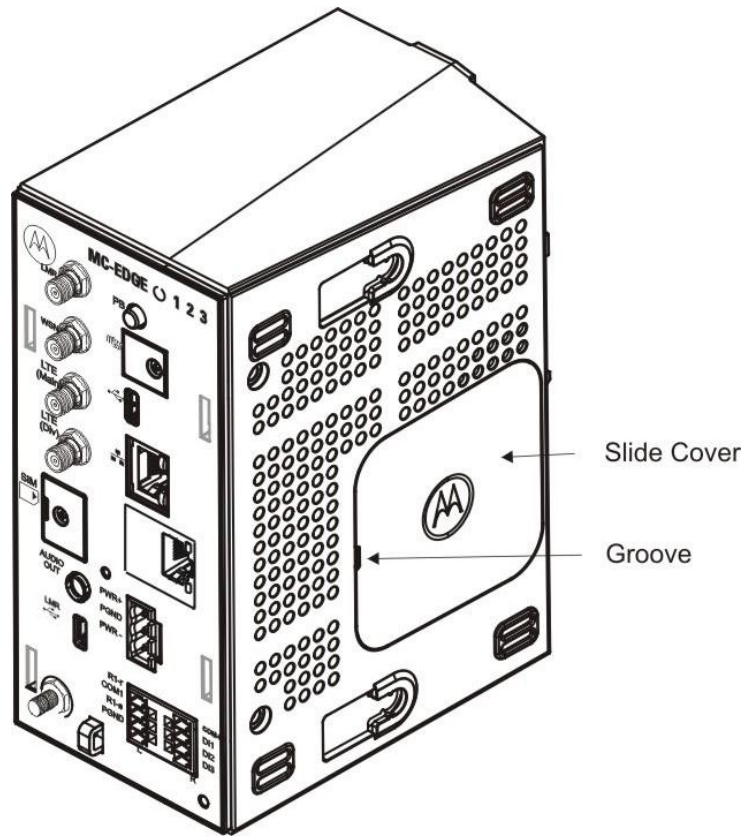

2. Click the 90° bent end of the 10-pin I/O connector cable (#30013144001) into the RJ50 connector on the right side of the CPU. See Figure 16.

Figure 16. MC-EDGE CPU Connection to I/O Expansion Module

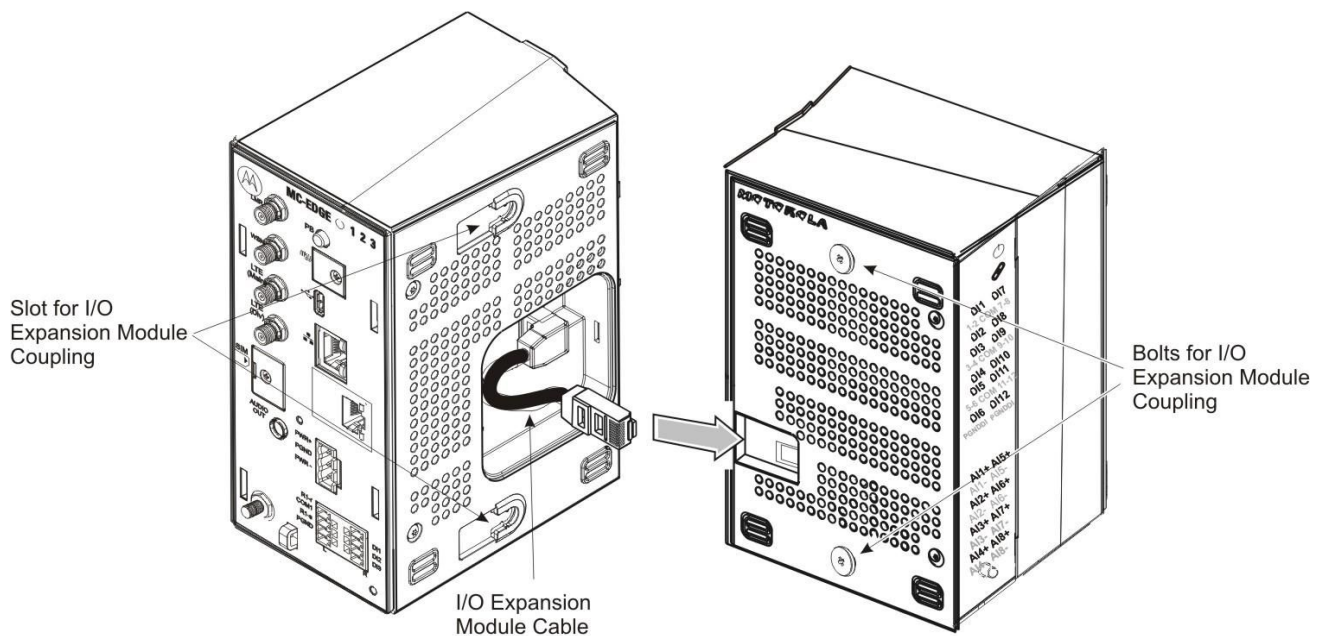

3. Click the other end of the I/O 10-pin connector cable into the RJ50 connector on the left side of the I/O expansion module. See Figure 16.
4. With the front of the modules facing you, press the CPU and I/O expansion modules together while sliding the bolts on the I/O expansion module into the slots on the CPU. Be careful not to pinch the cable between the modules.
5. Press the I/O expansion module slightly back and the CPU module slightly forward until they click.

Connecting an I/O Expansion Module to another I/O Expansion Module

Follow the procedure below to connect more than one I/O expansion module to the MC-EDGE unit.

Procedure 3. Connecting an I/O Expansion Module to another I/O Expansion Module

1. Remove the cover from the right side of the MC-EDGE I/O expansion module.
2. Click the 90° bent end of the 10-pin I/O connector cable into the RJ50 connector on the right side of the leftmost I/O expansion module. See Figure 17.

Figure 17. MC-EDGE I/O Expansion Module Connection to I/O Expansion Module

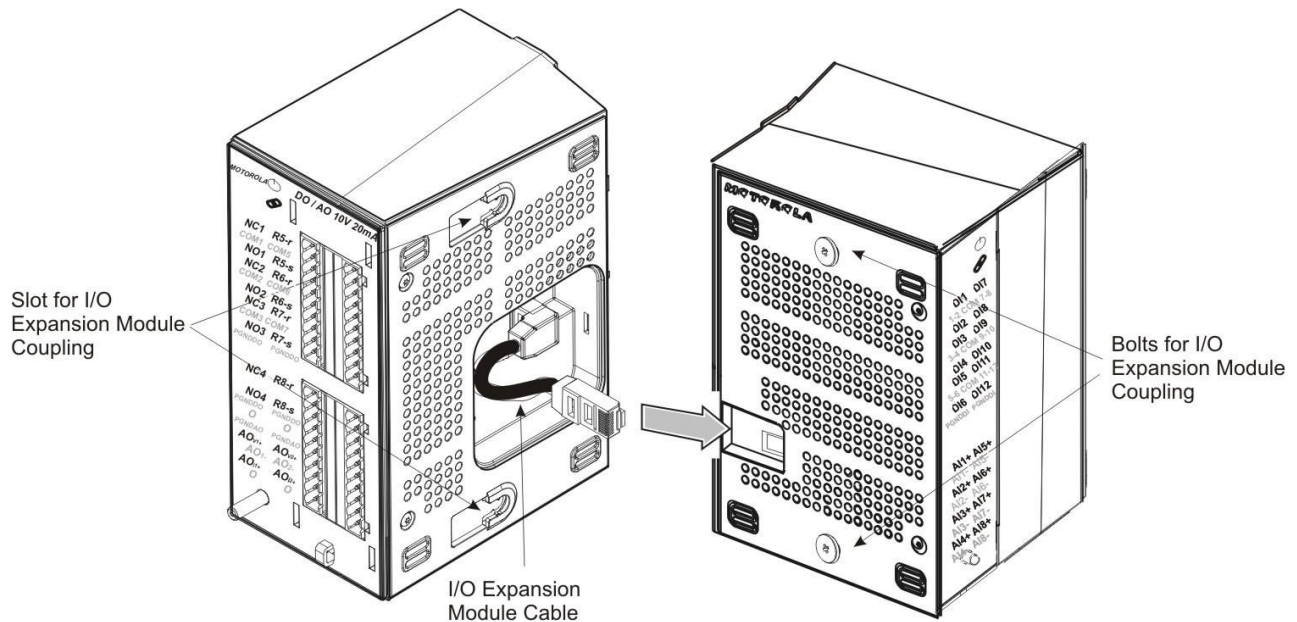



3. Click the other end of the I/O 10-pin connector cable into the RJ50 connector on the left side of the next I/O expansion module. See Figure 17.
4. Press the two I/O expansion modules together while sliding the bolts on the rightmost module into the slots on right side of leftmost module. Be careful not to pinch the cable between the modules.
5. Press the rightmost module slightly back and the leftmost module slightly forward until they click.

MC-EDGE Power and Ground Connections

All internal electrical connections are performed in the factory and supplied with the RTU. During installation, only the main power and ground must be connected.

The procedures for the main power, ground and battery connections are provided below.

 **WARNING:** The power and ground connections should be performed only by qualified and authorized service personnel. All power and ground connections must be in accordance with local standards and laws.

 **AVERTISSEMENT:** Les connexions d'alimentation et de mise à la masse doivent uniquement être effectuées par un personnel de service qualifié et autorisé. Toutes les connexions d'alimentation et de mise à la masse doivent être conformes aux normes et aux lois locales.

 **NOTICE:** Make sure that the ground cable is long enough to reach the grounding point, but as short as possible. The wire gauge of the ground wire in the cable must be 6 AWG.

Only a single wire can be connected to a contact in the Terminal Block connector. Wire size for the CPU Power connector must be AWG 12.

Connecting the MC-EDGE to Power and Ground

Follow the procedure below to connect the MC-EDGE unit to power and ground. See Figure 2- 9 and Figure 2-10.

Procedure 4. Connecting the MC-EDGE to Power and Ground

1. Once the MC-EDGE unit (including any I/O expansion modules) is installed on the DIN rail, mount the power supply (not supplied) nearby.
2. Connect one end of the DC power cable (FKN0033) to the 9-30 VDC power supply (red to + and black to -).

 **NOTICE:** The DC power cable includes a 5A fuse.

Figure 18. MC-EDGE DC Power Cable with Fuse



3. Connect the other end of the power cable to the DC power connector on the front panel of the MC-EDGE unit.
4. Connect the yellow wire from the power cable to the grounding screw on the front panel of the MC-EDGE unit.
5. Connect the protective ground cable (optional FKN0034) between the grounding screw on the unit (CPU or I/O expansion module) (ground screw nuts torque 4 LB-IN) to the grounding point outside of the enclosure. In an MC-EDGE unit with I/O expansion, all grounding strips should be connected to a common grounding point.
6. Bundle the cables as described in *Bundling MC-EDGE Cables*.
7. Connect the power supply power cable (AC power cable is not supplied).

Contact Us

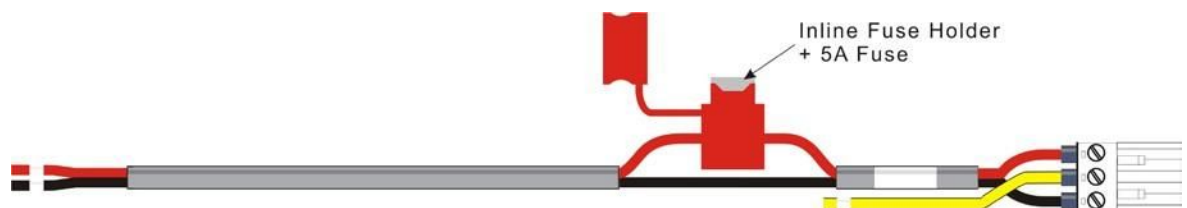
Figure 19. MC-EDGE Power and Ground Connections

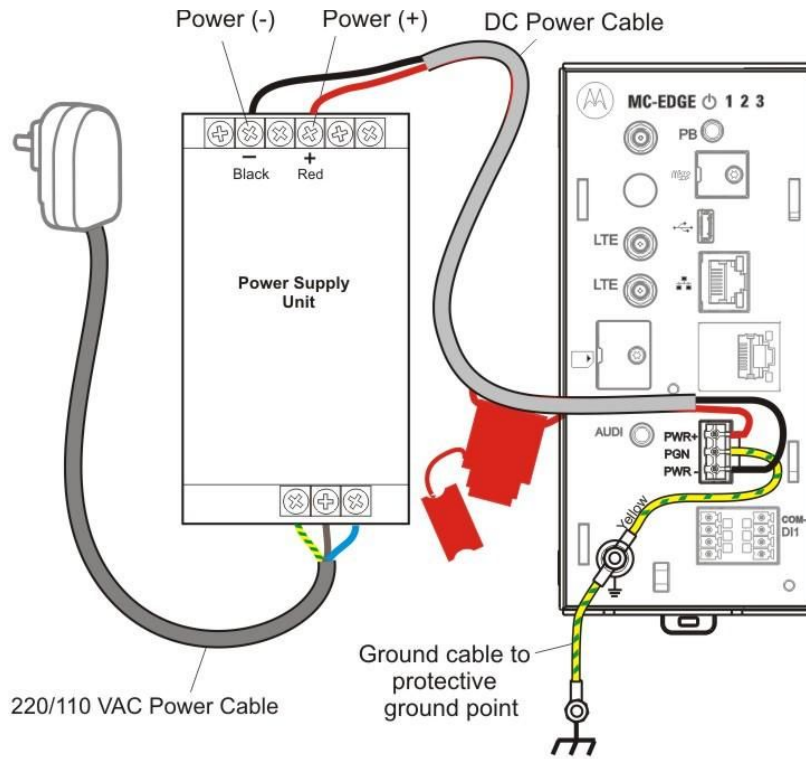
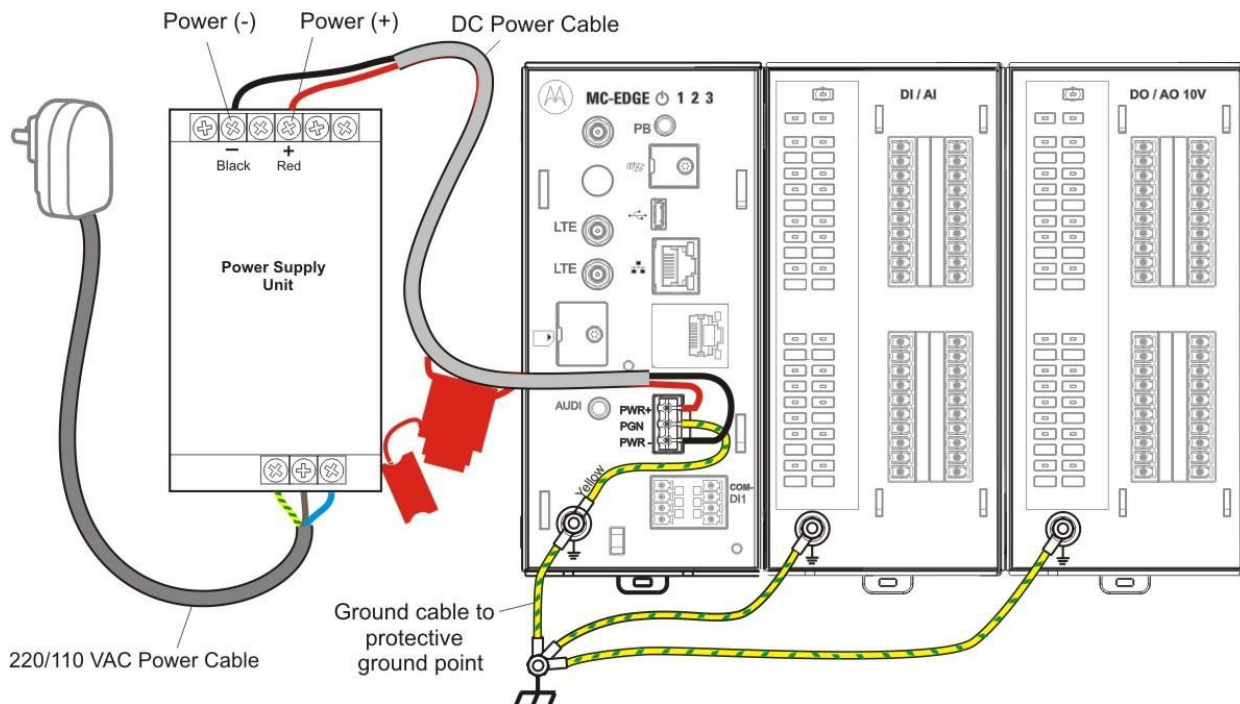

Figure 20. MC-EDGE with I/O Expansion Power and Ground Connections



Connecting MC-EDGE Data Cables

Follow the procedure below to connect the data cables to the MC-EDGE RTU ports.

Procedure 5. Connecting the MC-EDGE Data Cables

1. Connect the data cable(s) (RS232, RS485, LAN) from the MC-EDGE CPU to the appropriate device(s). For details, see *Appendix B: Cables and Adaptors*.
2. Bundle and attach the cable(s) to the fastener on the CPU module, as described in *Bundling MC-EDGE Cables*.

Connecting MC-EDGE I/Os

Follow the procedure below to connect a user-supplied I/O sensors/device to the MC-EDGE RTU I/O modules.



NOTICE: Only a single wire can be connected to a contact in the TB connector. Wire size for the CPU I/O connectors can be AWG 16,18,20,22,24,30. Wire size for the I/O expansion module connectors can be AWG 12,14,16,18,20,22,24,26. Wire size for the PGND in must be AWG 12.

Procedure 6. Connecting the MC-EDGE I/Os

1. Using a small flat screwdriver, loosen the screws on the TB connector (#FHN0061A). Insert the exposed wire tips from the I/O sensors/devices. Tighten the screws (torque 2 LB-IN).
2. Line the TB connector up to the corresponding connector on the I/O module and press it forward into the module, as shown in Figure 22. Then press downwards to lock.

Figure 22. MC-EDGE I/O Module with TB Connector

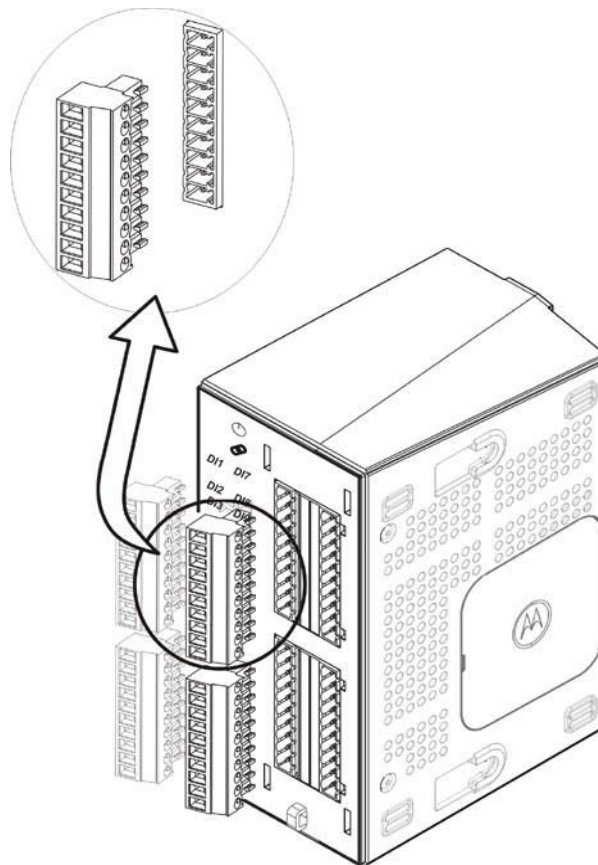

3. Bundle and attach the I/O cables to the fastener on the I/O module, as described in *Bundling MC-EDGE Cables*.

Bundling MC-EDGE Cables

All MC-EDGE cables must be bundled in a tear-off cable tie for strain relief at the bottom of the module's front panel. Follow the procedure below to bundle the MC-EDGE cables.

Procedure 7. Bundling the MC-EDGE Cables

4. Once all cables are connected to the module, collect all cables in one or more tear-off cable tie(s) (not supplied). See Figure 23.
5. Thread the cable tie through the plastic fastener at the bottom of the front panel. See Figure 24.

Figure 23. MC-EDGE Cables in Plastic Fastener

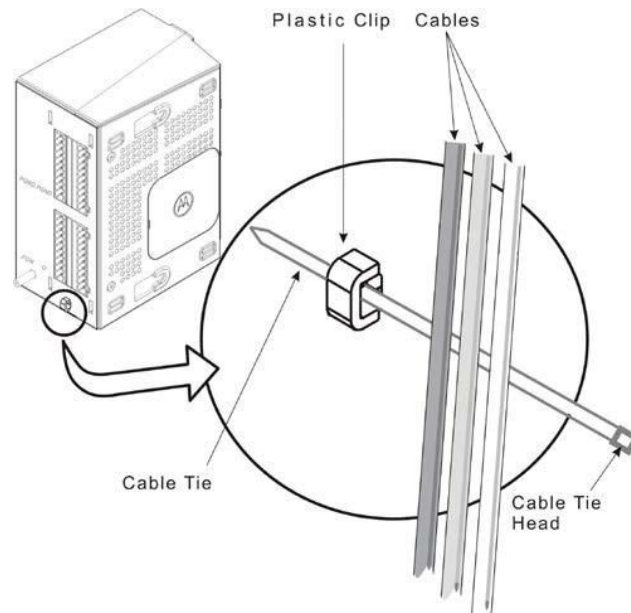

6. Slide the pointed tip of the cable tie through the head and pull tightly.
7. Snip off the extra plastic at the end of the tie.

Extracting Terminal Block Connectors from the I/O Module

Follow the procedure below to extract the TB connector from an MC-EDGE I/O module.

Procedure 8. Extracting the TB Connector from the I/O Module

8. Lift and remove the cover of the I/O module to expose the TB connectors. (See I/O module with and without cover in Figure 3.)
9. Position the TB extractor to the right of the preferred TB connector, and fit the curved tip behind the TB. (See Figure 24)
10. Press down on the TB extractor and rotate counter clockwise, and then rotate clockwise to extract the TB connector from the I/O module.

Contact Us

Figure 24. TB Extractor on TB

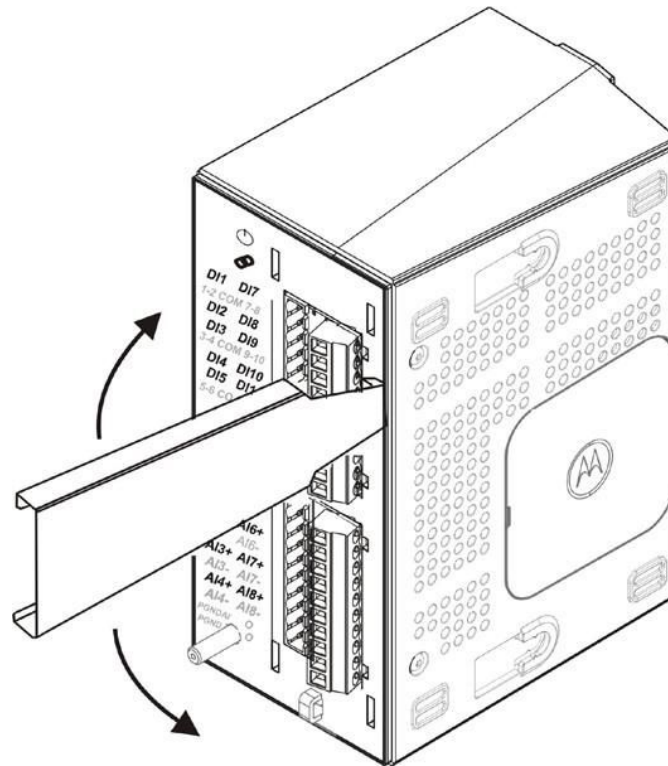

Adding an Optional SD Card

Follow the procedure below to add an optional SD card (not supplied) to an MC-EDGE CPU.

Procedure 9. Adding an Optional SD Card

1. Using a Phillips screwdriver, loosen the screw on the SD cover (torque 2 LB-IN). See Figure 25.
2. Gentle pull the screw outwards, on its axis, to remove the SD cover.

Figure 25. MC-EDGE CPU SD Cover

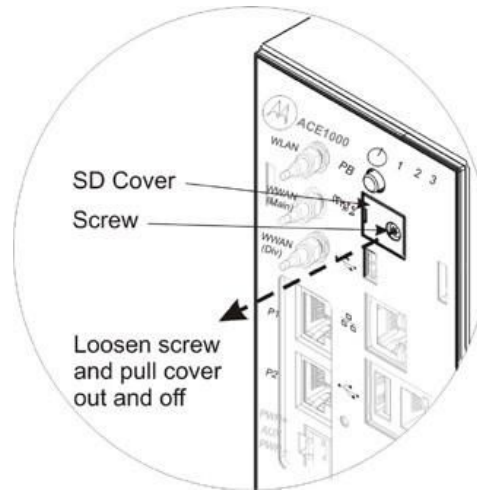

Connecting Antennas to the MC-EDGE

Once the MC-EDGE unit is installed, install the supplied antennas and connect the antenna cable connectors on the front panel of the MC-EDGE unit.

Before installing the antennas, read the installation instructions provided with each antenna installation kit.



NOTICE: Before installing the antennas, refer to RF Energy Exposure Training and Product Safety Information for Fixed Site Infrastructure Installed as Fixed Site Stations guide P.N: MN004607A01-A

To install the MC-EDGE, refer to [Figure 26](#).

Contact Us

Figure 26. Outdoors Installation of MC-EDGE Antennas

Keep at least 25 to 20cm lateral distance between antennas

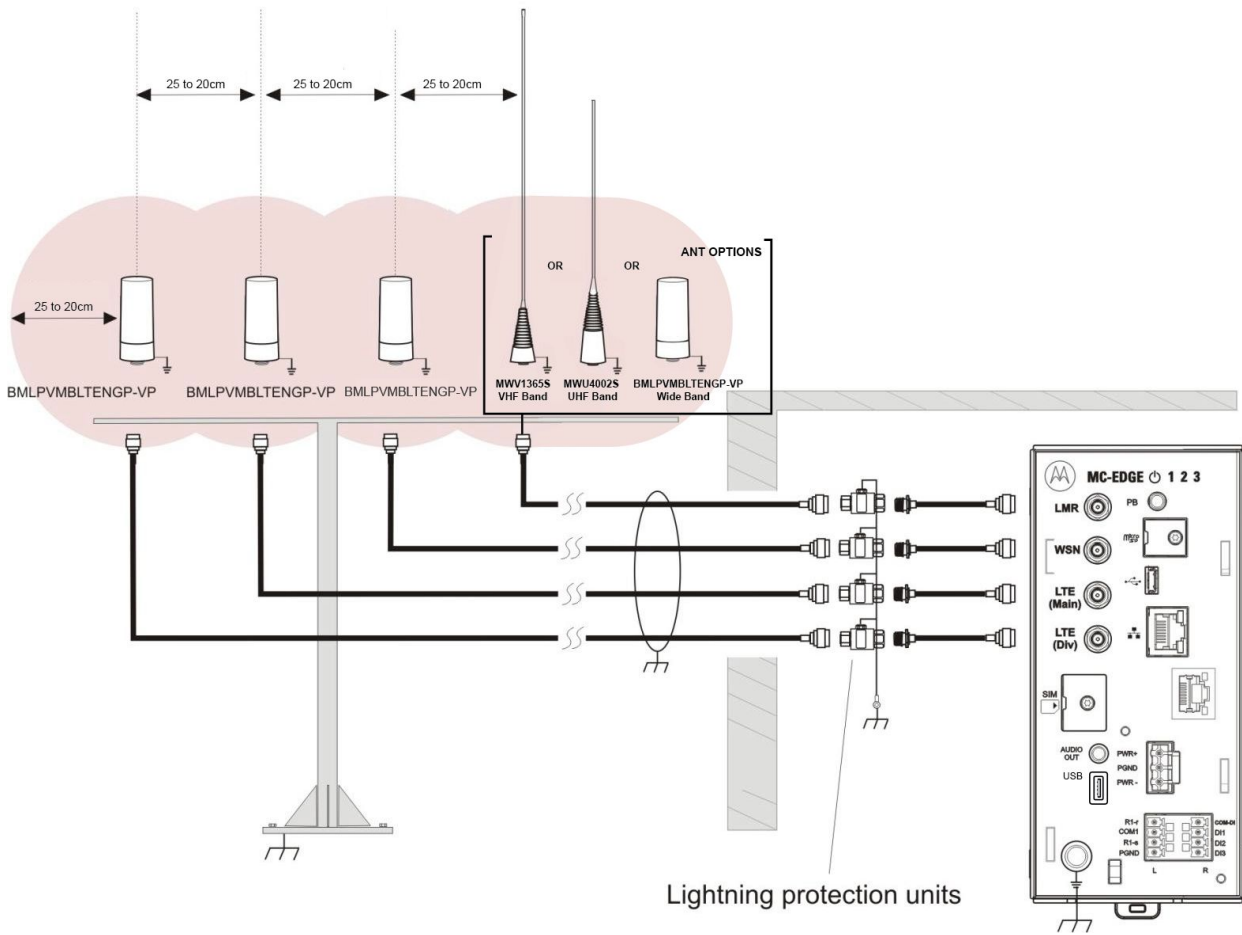

Replacing the MC-EDGE DC Power Cable Fuse

Follow the procedure below to replace the fuse on the MC-EDGE DC power cable (FKN0033).

Procedure 10. Replacing the MC-EDGE DC Power Cable Fuse

1. Remove the faulty 5A fuse from the fuse holder. See Figure 18.
2. Plug the new 5A fuse (# 6580283E03) into the fuse holder.

Optional Auxiliary Radios and Installation Kits

MC-EDGE Supported Radio Types

The MC-EDGE RTU supports a set of radios. See Table 8.

The APX™ and MOTOTRBO™ radios are connected to the USB OTG port. The TETRA radio and the modems are connected to an RS232 port. For information on configuring CPU ports for various radios/modems, see the *MC-EDGE Easy Configurator User Guide*.

All the radios listed below are external radios and should be operated according to their specifications. For complete radio specifications such as modulations, standards, Tx power output, Rx sensitivity, supply voltage, and power consumption, see the specific radio owner's manual.

Table 8. MC-EDGE Auxiliary Radios

| Description | Nomenclature | Band |
|---|---------------------|-------------|
| APX™ 6500Li P25 Mobile Radio, 136-174 MHz, 10-50W | M25KSS9PW1 N VHF | 136-174 MHz |
| APX™ 6500Li P25 Mobile Radio, 380-470 MHz, 10-40W | M25QSS9PW1 N UHF R1 | 380-470 MHz |
| APX™ 6500Li P25 Mobile Radio, 450-520 MHz, 10-45W | M25SSS9PW1 N UHF R2 | 450-520 MHz |
| APX™ 6500Li P25 Mobile Radio, 764-870 MHz, 10-35W | M25URS9PW1 N 7/800M | 764-870 MHz |

Installation Kits for MC-EDGE Auxiliary Radios

The following radio installation kits enable the user to install a radio in the MC-EDGE RTU.

Table 9. Installation Kits for MC-EDGE Auxiliary Radios

| Radios | Option/Kit |
|---------------|------------|
| APX™ 6500Li | FLN0100A |
| TETRA MTM5200 | FLN0043A |

For instructions on mounting the radio near the MC-EDGE unit, see the relevant installation instructions below.



NOTICE: A Torx screwdriver is required for the installation kits.

MTM5200, MOTOTRBO XPR 5350 and APX 6500 Radio

Installation Kits

The MTM5200, MOTOTRBO XPR 5350 and APX 6500 radio installation kits (MC-EDGE options FLN0043A, FLN0093A, VA00245AA and FLN0100A) enables the user to install the MTM5200, MOTOTRBO XPR 5350 and APX 6500 radios near the ACE100 RTU.

The following hardware and firmware are required:

1. MC-EDGE firmware 1.00 and above
2. ACE3600 System Tools Suite (STS) version 18.50 and above

The FLN0043A, FLN0093A, FLN0115A, FLN0100A installation kits include brackets, cables, and screws.

Note the MTM5200 works with the RS232 cable and RJ45 to DB9 adaptor (FKN022A). This is not the same adaptor that is used with the ACE3600.

Installing the Mobile Radio Installation Kits

Follow the procedure below to install the MTM5200, MOTOTRBO XPR 5350 and APX 6500 radio installation kits (FLN0093A, VA00245AA, FLN0042A, and FLN0100A).

Procedure 11. Installing the Mobile Radio Installation Kits

1. For the MOTOTRBO XPR 5350 and MTM5200 radios, adjust the bracket size. See *Making the Bracket Smaller for MOTOTRBO XPR 5350 and MTM5200 Radios*.
2. Place the bracket assembly (see Figure 3-1) on the DIN rail with the bracket hooked over the top of the DIN rail (see Figure 3-2.)

Figure 27. MTM5200, MOTOTRBO XPR 5350 and APX 6500 Radio Installation Kit Bracket Assembly

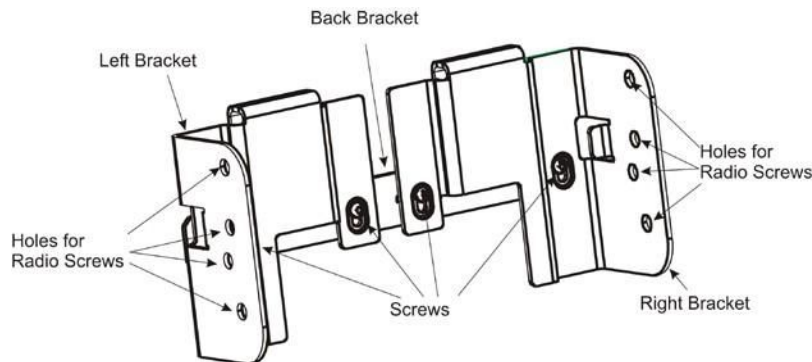

Contact Us

Figure 28. MTM5200, MOTOTRBO XPR 5350 and APX 6500 Radio Installation Kit Bracket Assembly on DIN Rail

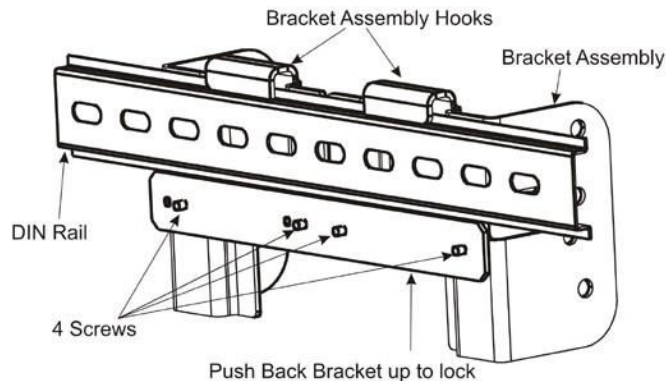

3. Push the back bracket up to lock the bracket assembly on the DIN rail.
4. Using a Torx T8 screwdriver, tighten the four screws in the bracket (See Figure 28).
5. Connect the data cable (FKN0027 9-pin connector for MTM5200, FKN0026 26-pin connector for XPR 5350 – digital mode, CB000344A01 26-pin connector for XPR 5350 – Connect Plus mode, and FKN0035 26-pin connector for APX 6500) to the Accessory connector on the back of the XPR 5350/ APX 6500 radio, or on the front of the MTM5200.
6. Connect the DC power cable (FKN0036) to the Power connector on the radio.
7. Put the radio into the bracket assembly, lining up the holes on the sides of the radio with holes on the side of the bracket (see holes in Figure 27).
8. For the APX 6500 radio, using an Allen wrench, screw in the four supplied screws, to attach the radio to the bracket assembly. See Figure 29.
9. For the MTM5200 and MOTOTRBO XPR 5350 radios, manually screw in the two supplied wing screws, to attach the radio to the bracket assembly. See Figure 30 and Figure 31.

Figure 29. APX 6500 Radio on DIN Rail

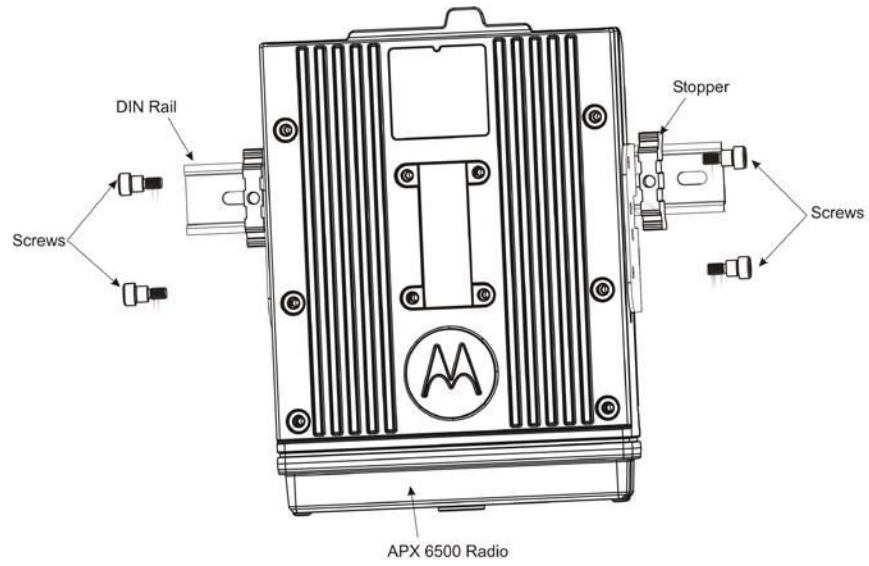

Figure 30. XPR 5350 Radio on DIN Rail

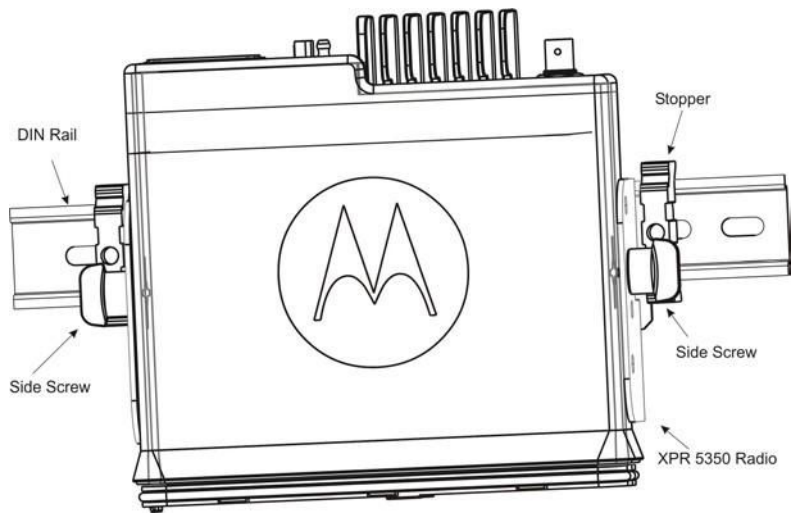
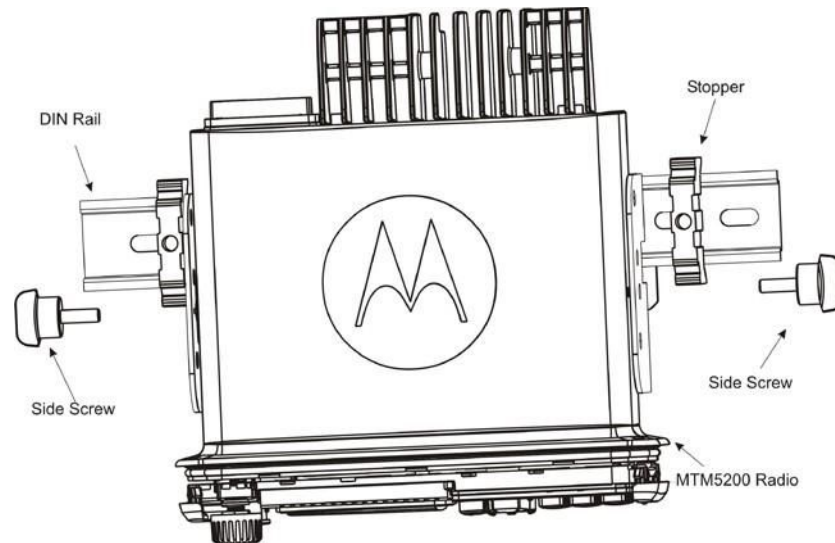

Figure 31. MTM5200 Radio on DIN Rail



10. (Optional) Clip two stoppers (see Figure 3-3, Figure 3-4, Figure 3-5) onto the DIN rail, one to the left and one to the right of the radio, to keep the radio in place. Tighten the built in screws.
11. Connect the communication cable to the MC-EDGE CPU module port configured for the radio (USB for APX 6500 and XPR 5350, or RS232 for MTM5200). See *Configuring the RTU Port Type for the APX 4000/APX 6500 Radio* below.
12. Connect the antenna cable/antenna according to the radio instructions.

Before operating the radio, the MC-EDGE RTU port must be configured for the radio, and the radio may need to be programmed using the appropriate CPS.

Configuration and Programming for the ASTRO APX 4000/APX 6500 Radio

To enable MDLC communication using the APX 4000/APX 6500 radio in an MC-EDGE-only system, configure the port via Web browser. See the “Configuring Communication in an MC-EDGE RTU” section of the *MC-EDGE Easy Configurator User Guide*. To configure the radio in a mixed system, see the procedure below.

Configuring the RTU Port Type for the APX 4000/APX 6500 Radio

Procedure 16. Configuring the MC-EDGE Port for the APX 4000/APX 6500 Radio

1. In the ACE3600 STS click on the preferred site, and open the site view.
2. In the Port Tab, click on the USB port through which the RTU will communicate with the APX 6500 radio.
3. Confirm that the port parameters and data speed are as shown in the screen below.
4. Define preferred links.

5. Save the changes.

RTU Port Type Advanced Parameter Configuration (for APX 4000/APX 6500 Radio)

Figure 44. RTU Site Configuration for MDLC over ASTRO APX Radio – Advanced Parameters

| Parameter | Default | Value |
|---|-------------|---------|
| Link ID Parameters | | |
| Link name: | | LINE 1 |
| TX to failed RTU every <0-DISABLE 0-30> min | [3]: | 3 |
| Periodic check of failed RTU | [Disable]: | Disable |
| Default group IP address: | [0.0.0.0]: | 0.0.0.0 |
| Get host by name using DNS | [Enable]: | Enable |
| Notify changes from other links | [Never]: | Never |
| MDLC over IP port number: | | |
| MDLC over IP port number: | [2002]: | 2002 |
| Enable sync | [Disable]: | Disable |
| Enable reply to time synchronization | [Disable]: | Disable |
| Enable routing on MDLC over IP port | [Disable]: | Disable |
| Notify IP address when connecting | [Enable]: | Enable |
| Notify private site IDs when connecting | [Enable]: | Enable |
| Check alive timeout (sec) <0-65535> | [35]: | 35 |
| Poll interval (sec) <0-255> | [10]: | 10 |
| Maximum number of polls <0-255> | [3]: | 3 |

Generally no other changes are required to Advanced Physical or Link Layer parameters. For information on these parameters, see the “MDLC over IP” chapter of the *ACE3600 STS Advanced Features* manual.

Procedure 17. Configuring the Advanced Parameters of the MC-EDGE Port for the ASTRO APX Radio

1. If any changes are required, click on the appropriate screen in the Port Tab.
2. Change the settings as necessary.



NOTICE: The Default Group ID Address should be left 000.000.000. The actual values will be read by the RTU from the radio upon connection.

3. Save any changes.
4. Save the project.
5. Download the site configuration to the MC-EDGE RTU.

IP Conversion Table for the APX 4000/APX 6500 Radio

Prepare an IP conversion table if the RTU must communicate with another RTU or an IP Gateway. In the IP conversion table, specify the IP address of each RTU port (site ID + link ID). This IP address is assigned by the infrastructure operator.

Note that an IP address is obtained from the radio once it is connected to the RTU port over

Contact Us

USB. The IP address obtained from the radio is not the real IP address set by the infrastructure, but rather a dummy address. This dummy is configured in the radio via the CPS Mobile Computer IP address parameter (by default 192.168.128.2).

When device LINxL level 0 is retrieved using the MC-EDGE STS Software Diagnostics tool, the IP Address displayed is this dummy address and not the actual IP address assigned by the infrastructure operator.

It is recommended to create two IP conversion tables:

1. The first is downloaded to the FIU or IP Gateway on the LAN and includes the site and IP information for each RTU.
2. The second is downloaded to all RTUs which are connected to the infrastructure with ASTRO IV&D radios, and includes the site and IP information for the FIU and IP Gateway.

For detailed instructions on preparing the IP conversion table, refer to the “MDLC over IP Communication” chapter of the *ACE3600 STS Advanced Features* manual.

APX 4000/APX 6500 Radio Programming using CPS

The APX 4000/APX 6500 radio is programmed for MC-EDGE in the factory and is ready for digital ASTRO IV&D trunked communication. For user programming of site-specific parameters, the radio should be brought to the Motorola Service Center.

Connecting the APX 4000/APX 6500 Radio

To program the APX 4000/APX 6500 radio with Customer Programming Software (CPS), the radio must be connected to a PC.

Procedure 18. Connecting the APX 4000/APX 6500 Radio to the CPS

1. Connect one end of the programming cable (PMKN4012B for APX 4000, HKN6184C for APX 6500) to the Accessory connector on the radio. The HKN6184C programming cable is not supplied and must be ordered separately.
2. Connect the other end to the USB port of a PC on which the ASTRO CPS software (RVN4185) is installed.

Disassembling the APX 6500 Radio

If the APX 6500 radio is to be programmed at an authorized laboratory, disassemble the radio from the MC-EDGE unit as follows:

Procedure 20. Disassembling the APX 6500 Radio

1. Disconnect the antenna cable from the Antenna connector on the APX 6500 radio.
2. Disconnect the DC power cable (FKN0036) from the Power connector on the radio.
3. Disconnect the connector of the data cable (FKN0035) from the Accessory connector on the radio.
4. Using an Allen wrench, unscrew the four screws which attach the radio to the bracket assembly. See Figure 3-3.
5. Remove the radio from the DIN rail.
6. Take the radio to a laboratory to be programmed as described in CPS Programming

Settings below.

Programming the APX Radio

Follow the procedure below to change the APX 4000/APX 6500 radio settings for ASTRO IV&D trunking using the CPS.

Procedure 21. Programming the APX Radio Settings

1. Open the codeplug in the CPS (either by reading the radio or by opening the already saved codeplug).
2. In the navigation pane extend the Codeplug Configuration tree and select the 'Radio Wide'.
3. In the 'Features' section set the 'Ignition Switch' to 'Soft Power Off'.
4. Extend the 'Radio Ergonomics Configuration' branch, select the 'Radio Ergonomics Wide' and in the 'Advanced' section enable the 'Last selected Channel Per Zone Enable' option.
5. Extend the 'Data Configuration' branch and select the 'Data Wide'.
6. In the 'NAT List' section, add an entry to the NAT List (the Plus sign):
7. The 'WAN port' should be set to the MDLC over IP port number (e.g. 2002).
8. The 'LAN port' should be set to the MDLC over IP port number (e.g. 2002).
9. The 'Static NAT IP Address' should be set to the Peer IP Address (e.g. 192.168.128.2).
10. Under the 'Data configuration' branch, extend the 'Data Profile' branch and select 'Profile 1'.
11. In the 'General' section, set the 'Data Profile Type' to 'Trunking'.
12. In the 'General' section, disable the 'RX Voice Interrupts Data' option.
13. In the 'Features' section, enable the 'Terminal Data' option.
14. Extend the 'Trunking configuration' branch, then extend the 'Trunking System' branch and select the 'Trk Sys 1'.
15. In the 'General' section:
16. Set the 'System Type' to 'ASTRO 25'. If the proper system key was loaded, the System Key field should already be enabled.
17. Set the 'System ID', 'Home WACN ID' and 'Unit ID' to values obtained from the radio system administrator.
18. Set the 'Coverage Type' to 'SmartZone'.
19. Select 'Profile 1' in the 'Data Profile Selection' option box.
20. In the 'Control Channels' section, enter the control channels with which the data subscriber should be able to affiliate. Consult your radio system administrator for the list of control channels.
21. In the 'ASTRO 25 Channel ID' section, enable at least the first channel.
22. Under the 'Trunking configuration' branch, extend the 'Trunking Personality' branch

Contact Us

and select the 'Trk Per 1'.

23. In the Talkgroup section, set the radio talkgroup ID value in hexadecimal. Consult your radio system administrator for the talkgroup information.
24. Extend the 'Zone Channel Assignment' branch and select the '1-Zone 1'.
25. In the 'Zone section', set the Zone to the preferred zone name (e.g. ZONE1).
26. In the 'Channels' section,
27. Add the amount of needed channels - Consult your radio system administrator for the talkgroup information.
28. Set the 'Channel name' which will be displayed on the radio screen (if the radio is Model II or III).
29. Select the 'Channel Type' as Trk in each channel
30. Select the 'Personality' of that channel (if you have more than one trunking personality configurations).
31. Specify the 'Trunking Talkgroup' of each channel.
32. Select File -> Save to save changes to the radio.
33. Select File -> Write Device to download the configuration to the radio.

Infrastructure Configuration for the APX 6500 Radio

In order for the MC-EDGE RTU to communicate over the ASTRO IV&D infrastructure using the APX 6500 digital radio, the infrastructure must be properly configured using the UCM (User Configuration Manager) tool.



NOTICE: If configuring a border router or any firewall within the CEN (Customer Enterprise network), make sure that the MC-EDGE's MDLC over IP UDP port number 2002 is enabled for inbound and outbound messages.

In the UCM Radio User Data Settings tab, be sure to set the IP address as Static, to enable Generate ICMP and Source Address Checking, and the Ready timer set to 10 seconds.

Set the "Ignore Affiliation Inactivity Timeout" setting to Enabled.

ASTRO APX 6500Li Options for MC-EDGE

All of the following options should be ordered with the APX 6500Li Radio:

Table 10. ASTRO APX 6500Li Options for MC-EDGE

| Option Name | Option Number |
|--------------------------------|---------------|
| ADD: NO SPEAKER NEEDED APEX | G142AD |
| ADD: O5 CONTROL HEAD | G442AJ |
| ADD: APX CONTROL HEAD SOFTWARE | G444AE |
| ADD: DASH MOUNT | G66AM |
| ADD: NO RF ANT NEEDED | G89AC |
| ADD: NO MICROPHONE NEEDED | G90AC |

| | |
|-------------------------------------|-----------|
| ADD: TDMA OPERATION | GA00580AA |
| ADD: DATA LINK MANAGER | QA00205AH |
| ENH: 9600 OR 3600 SINGLE SYSTEM DIG | QA02756AC |
| ADD: ENHANCED DATA APX | QA03399AA |

Appendix A: MC-EDGE Specifications

MC-EDGE General Specifications

Table 14. MC-EDGE General Specifications

| Attribute | Specifications |
|-------------------------|--|
| CPU MODULE | |
| Processor | TI Sitara Cortex A8 AM3356 microprocessor |
| Frequency | 600 MHz (default), 300 MHz in Low Power mode configuration |
| ON-BOARD RADIOS | |
| LoRaWAN (Future Option) | <ul style="list-style-type: none"> - Wireless Sensors Network Class 1, 8 Channels - Radio Chipset: SX1301 & SX1257 - Freq range: 902 to 928 MHz - RX Sensitivity: Up to -140dBm - Max RF Output: +27dBm - External Network Server - Optional - Clear LoRa – Optional |
| APX4000 | <p>Land Mobile Radio ASTRO P25</p> <p>700/800:</p> <ul style="list-style-type: none"> - Tx Bands: 763-776,793-806 MHz / 806-825,851-870 MHz - Rx Bands: 763-776 MHz / 851-870 MHz - C.Spacing: 25/12.5 KHz -RF OutPut Power: 1-3 W - Rx Sensitivity (12dB SINAD):0.250uV <p>VHF:</p> <ul style="list-style-type: none"> - Tx /Rx Bands: 136-174Mhz - C. Spacing: 30/25/12.5 KHz - RF OutPut Power: 1-5 W - Rx Sensitivity (12dB SINAD):0.216uV <p>UHF R1,R2:</p> <ul style="list-style-type: none"> - Tx Bands: 380-470,480-520 Mhz - Rx Bands: 340-470,450-520 MHz - C.Spacing: 25/12.5 KHz -RF OutPut Power: 1-5 W - Rx Sensitivity (12dB SINAD):0.234uV 900 MHz: - Rx /Tx Bands: 896-902,935-941MHz - C.Spacing: 12.5 KHz |

LTE

-RF OutPut Power: 1-2.5 W
 - Rx Sensitivity (12dB SINAD):0.236uV
 LTE Air Prime HL7588
 B4 B13 per 3GPP
 Table 11.Supported Bands

| RF Band | Transmit Band (Tx) | Receive Band (Rx) | Maximum Output Power |
|---------|--------------------|-------------------|--------------------------------|
| LTE B4 | 1710 to 1755 MHz | 2110 to 2155 MHz | 22.5 dBm (+/- 2dBm) Class 3bis |
| LTE B13 | 777 to 787 MHz | 746 to 756 MHz | 22.5 dBm (+/- 2dBm) Class 3bis |

Sim Interface

- 1.8V/3.3V support
- Conforms with ETSI UICC Specifications
- SIM/USIM support

Table 13.Table Conducted RX Sensitivity (dBm)

| Frequency Band | | Primary (Typical) | Secondary (Typical) | SIMO (Typical) |
|----------------|----------------------|-------------------|---------------------|----------------|
| LTE B4 | Full RB; BW: 20 MHz* | -94.5 | -94.5 | -97.5 |
| LTE B13 | Full RB; BW: 10 MHz* | -97.5 | -98.5 | -101.5 |

* Sensitivity values scale with bandwidth: $x_MHz_Sensitivity = 10 MHz_Sensitivity - 10 \cdot \log(10 MHz/x_MHz)$

| | |
|------------------------------------|---|
| MEMORY | |
| Flash | 256 MB, at least 32 MB available for user data |
| DDR | 256 MB LPDDR memory, at least 32 MB available for user data |
| Micro SD Card Slot | Micro SD Card Slot for user logging or CRYPTR |
| Optional user-supplied flash drive | Up to 32 GB on Sandisk Cruzer Blade (SDZ50-032G) or 4GB on Sandisk Cruzer Blade (SDZ50-004G) (not supplied) |
| <hr/> | |
| CPU | SITARA TI AM3356 Cortex A8 microprocessor Clock: 600 MHz (default), 300 MHz (low power) |

Contact Us

| Operating System | Linux (Kernel version 4.9) |
|-------------------------|---|
| Real Time Clock | Hardware clock with year, month, date, day, hour, minute, and second supported. |
| Internal Backup Battery | The backup battery can maintain the RTC for at least 30 days@ +25°C, when main power is disconnected. |
| Real Time Clock (RTC) | ±20ppm@25C or 2sec per day (24hours) @ 25C ±0.04ppm/(°C) ² |
| POWER IN | Hardware clock with year, month, date, day, hour, minute, and second Leap years support RTC crystal accuracy: max. ±20ppm@25 °C RTC crystal drift: ± 0.04ppm/ °C RTC Internal Backup Battery – Backup for at least 30 days @ 25 °C |
| Input Voltage | 9-30 V DC |
| Power In Connector | 5mm pitch, Maximum 12 AWG |
| Power Consumption | CPU module All Radio Off: max. 300mA / typ. 150mA @ 12V (w/o SD card and USB) CPU module All Radio On: max. 450mA / typ. 250mA @ 12V (w/o SD card and USB) Input module: max. 180mA / typ. 100mA @ 12V Output module: max. 450mA / typ.250mA @ 12VMixed IO module: Max 194.4mA@12V/Typical 64mA@12V Sleep mode: typical 5.5 mA @12V |
| Attribute | Specifications |
| ENVIRONMENTAL | |
| Physical Dimensions | 7.6 cm (W) x 15.9 cm (H) x 11.8 cm (D) (3" x 6.3" x 4.7") (WxHxD) The depth of the unit including the front cover is 14.59 cm (5.74"). The depth to the tip of the grounding screw is 13.73 cm (5.41"). |
| Weight | Approx. 0.5 Kg |
| DIN Rail | Maximum thickness 1.0 mm Minimum length 26 cm |
| Operating Temperature | -30 °C to +60 °C (-4 °F to 122 °F) |
| Storage Temperature | -55 °C to +85 °C (-67 °F to 185 °F) |
| Operating Humidity | 5% to 95% RH @ 50 °C for 8 hours without condensation. For an uncontrolled humidity environment, it is recommended to use an enclosure |
| Housing Sealing | IP30 |
| Mechanical Vibrations | EIA/TIA 603 Base station, Sinusoidal 0.07mm @ 10-30 Hz, 0.035 mm @ 30-60 Hz |

| | |
|---|--|
| Operating Altitude | -400 to +4000 meter (-1312 to + 13120 ft) |
| Communication Ports | Serial RS232/RS485 port (configurable) - RS-232 up to 115.2 Kb/s - RS485 up to 460.8 Kb/s USB ports: - USB 2.0 On-the-Go - USB 2.0 Host Ethernet port : -10/100 Mb/s Optional plug-in ports with two RS232 ports: - Up to 115.2 Kb/s 2 isolated (2500V) |
| CPU ON-BOARD I/O | |
| <u>Digital Inputs</u> | |
| Total Number of Inputs | 3 DI Wet inputs |
| DI Fast Counter Input Mode | Max 2.0 kHz (minimum pulse width 250 μ S) |
| Max. DC Input Voltage | 30V DC |
| “ON” DC Voltage Range | +6 to 30V DC |
| “OFF” DC Voltage Range | 0 to +3V DC |
| Input Current | Max 8 mA@30V DC |
| DI Isolation to CPU | 2500 V |
| <u>Digital Output</u> | |
| Total Number of Outputs | 1 Magnetically Latched (ML) |
| DO Max. Contact Ratings | 2A@30VDC or 0.6A@30VAC |
| DO Isolation | 1500V |
| Maximum Number of I/O Expansion Modules | 2 |
| PROTOCOL SUPPORT | |
| MDLC | Serial/Ethernet/USB |
| MODBUS Master | Serial/Ethernet |
| MODBUS Slave | |

Contact Us

CONFIGURATION & PROGRAMMING TOOLS ACE3600 STS

| | |
|---------------------|--|
| CodeSys Programmer | Configuration (Mixed System only) |
| 'C' Programming SDK | IEC61131-3 compliant application 'C' Language API |

| | |
|----------------------|---|
| Time Synchronization | NTP, MDLC Ext. GPS/GLONASS, NMEA-0183, 1PPS, RS232 |
|----------------------|---|

| | |
|----------|-----------------|
| Security | HTTPS, SSL, SSH |
|----------|-----------------|

MC-EDGE Input Module Specifications

The MC-EDGE input module (mixed DI/AI) specifications are listed below.

Table A-2 MC-EDGE Input Module Specifications

| Attribute | Specifications |
|--------------------------------------|--|
| Total Number of Inputs | 12 DI wet inputs 8 AI: 0-20 mA (4-20 mA), 0-5 VDC differential inputs |
| Digital Inputs | |
| DI Fast Counter Input Mode Frequency | Max 2.0 kHz (minimum pulse width 250 μ S) |
| Max. DC Input Voltage | 30V DC |
| "ON" DC Voltage Range | +6 to 30V DC |
| "OFF" DC Voltage Range | 0 to +3V DC |
| Analog Input | |
| Input Current | Max 8 mA@30V DC |
| DI De-bouncing Filter | 10, 20, 30, 40, 50 msec |
| Diagnostic LEDs | Status LED per each input |
| User Connection | 2 Terminal Blocks, with maximum 12 AWG |
| DI Isolation to CPU | 2500 V |
| Analog Inputs | |
| A/D resolution | 16 bit (including sign) |
| AI Accuracy | \pm 0.1% of full scale |
| AI Temperature Drift | \pm 25PPM/C |
| AI Smoothing | User configurable |
| AI Scaling | User configurable (positive range only) |

| | |
|---------------------|---|
| AI Fast sampling | User configurable: No filtering – 10 samples /sec 60 Hz filtering – 7.5 samples /sec 50 Hz filtering –6.25 samples /sec |
| Impedance | Voltage channels - range 0 -5 V, 200K input impedance or Current channels - range 0 -20 mA, 250 Ω input impedance |
| Physical Dimensions | 7.6 cm (W) x 15.9 cm (H) x 11.8 cm (D) (3" x 6.3" x 4.7") (WxHxD) The depth of the unit including the front cover is 14.59 cm (5.74"). The depth to the tip of the grounding screw is 13.73 cm (5.41"). |
| Weight | 0.82 Kg (1.64 Lb) |

MC-EDGE Output Module Specifications

The MC-EDGE output (mixed DO/AO) module specifications are listed below.

Table A-3 MC-EDGE Output Module Specifications

| Attribute | Specifications |
|---------------------------|---|
| Total Number of Outputs | 8 DO: 4 ML/4 EE Form C (SPDT) 2 AO: current (0-20 mA) or voltage (0-10 V) |
| Digital Outputs | |
| DO Frequency | Max 10 Hz |
| DO Max. Contact Ratings | 2A@30VDC or 0.6A@30VAC |
| DO Isolation | 1500V |
| Analog Output | |
| Output Arrangement | 0-20 mA or 0-10 V DC voltage; no isolation between channels |
| D to A Resolution | 12 bit |
| AO Accuracy | $\pm 0.1\%$ of full scale @ 25 °C |
| AO Temperature Stability | $\pm 0.5\%$ of full scale @ all range |
| AO Internal Settling Time | 1mS |
| AO Load | Voltage: >1K Ω Current: <1K Ω |
| Output Protection | Voltage output: short circuit current, max. 35mA Current output: No-load voltage max. 31V DC |
| User Connection | 2 Terminal Blocks, with maximum 12 AWG |
| Isolation to CPU | 1.5 kV between output and module logic |
| Physical Dimensions | 7.6 cm (W) x 15.9 cm (H) x 11.8 cm (D) (3" x 6.3" x 4.7") (WxHxD) The depth of the unit including the front cover is 14.59 cm (5.74"). The depth to the tip of the grounding screw is 13.73 cm (5.41"). |
| Weight | approx. 0.5 Kg (1.64 Lb) |
| Power Consumption | Output module: max 450 mA @12V/typical 250 mA @12V |

Contact Us

MC-EDGE Mixed I/O Module Specifications

Table A-4 MC-EDGE Output Module Specifications

| Attribute | Specifications |
|--------------------------------------|---|
| Total Number of Outputs | 6 DO: 2 ML/4 EE Form C (SPDT) 1 AO: current (0-20 mA) or voltage (0-10 V) |
| Digital Outputs | |
| DO Frequency | Max 10 Hz |
| DO Max. Contact Ratings | 2A@30VDC or 0.6A@30VAC |
| DO Isolation | 1500V |
| Analog Output | |
| Output Arrangement | 0-20 mA or 0-10 V DC voltage; no isolation between channels |
| D to A Resolution | 12 bit |
| AO Accuracy | ±0.1% of full scale @ 25 °C |
| AO Temperature Stability | ±0.5% of full scale @ all range |
| AO Internal Settling Time | 1mS |
| AO Load | Voltage: >1K Ω Current: <1K Ω |
| Output Protection | Voltage output: short circuit current, max. 35mA Current output: No-load voltage max. 31V DC |
| User Connection | 2 Terminal Blocks, with maximum 12 AWG |
| Isolation to CPU | 1.5 kV between output and module logic |
| Total Number of Inputs | 7 DI wet inputs 4 AI: 0-20 mA (4-20 mA) |
| Digital Inputs | |
| DI Fast Counter Input Mode Frequency | Max 2.0 kHz (minimum pulse width 250 μS) |
| Max. DC Input Voltage | 30V DC |
| “ON” DC Voltage Range | +6 to 30V DC |
| “OFF” DC Voltage Range | 0 to +3V DC |
| Analog Input | |
| Input Current | Max 8 mA@30V DC |
| DI De-bouncing Filter | 10, 20, 30, 40, 50 msec |
| Diagnostic LEDs | Status LED per each input |
| User Connection | 2 Terminal Blocks, with maximum 12 AWG |
| DI Isolation to CPU | 2500 V |

Contact Us

| | |
|-----------------------------|--|
| Analog Inputs | |
| A/D resolution | 16 bit (including sign) |
| AI Accuracy | ± 0.1% of full scale |
| AI Temperature Drift | ±25PPM/C |
| AI Smoothing | User configurable |
| AI Scaling | User configurable (positive range only) |
| AI Fast sampling | User configurable: No filtering – 10 samples /sec 60 Hz filtering – 7.5 samples /sec 50 Hz filtering –6.25 samples /sec |
| Impedance | Voltage channels - range 0 -5 V, 200K input impedance or Current channels - range 0 -20 mA, 250 Ω input impedance |
| Physical Dimensions | 7.6 cm (W) x 15.9 cm (H) x 11.8 cm (D) (3" x 6.3" x 4.7") (WxHxD) The depth of the unit including the front cover is 14.59 cm (5.74"). The depth to the tip of the grounding screw is 13.73 cm (5.41"). |
| Weight | approx. 0.5 Kg (1.64 Lb) |
| Power Consumption all on | 194.4mA@12V |
| Power Consumption Idle | 64mA@12V |

MC-EDGE Regulatory Specifications

The MC-EDGE regulatory specifications are listed below.

Table A-6 MC-EDGE Regulatory Specifications

| Standard | Specification |
|-----------------|---|
| Safety | UL 60950-1 (UL listed) EN60950-1 |
| Emission | CFR 47 FCC part 15, subpart B (class A) |
| Housing Sealing | IP30 |

Appendix B: Cables and Adaptors

General

This appendix provides the information required for connecting an MC-EDGE RTU and ACE1100 FEP to various interfaces, as detailed below:

1. Connection to a computer via RS232
2. Connection to a modem via RS232
3. Connection to a PLC/RTU/FEP via RS232
4. Connection to a PLC/RTU/FEP via RS485
5. Connection to a computer via Ethernet
6. Connection to a computer via USB
7. MC-EDGE CPU to MC-EDGE I/O Expansion Module Connection



NOTICE: On the MC-EDGE RJ45 RS232 connector, the numbering of the pins is different than the ACE3600, as shown in Figure 61. Pin 8-1 are left to right. Therefore, only original Motorola MC-EDGE cables should be used.

Figure 61 MC-EDGE RJ45 RS232 connector

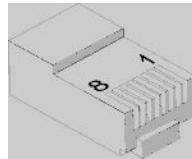

For information on connecting the MC-EDGE to a radio via USB or RS232, see *MC-EDGE Radio Types and Installation Kits*.

Connection to a Computer via RS232

Use this connection to configure an MC-EDGE mixed system using the ACE3600 STS.

To connect the unit's RS232 serial port to a computer, use the RS232 data cable (FKN0022), which includes an RJ45-to-RJ45 cable (3008439S01) and an adaptor (0189968V32) with a male 9-pin, D-type connector. Add a null modem cable (female-to-female) which is not provided. See Figure 62.



NOTICE: The FKN0022 adaptor is not the same adaptor that is used with the ACE3600.

Contact Us

Figure 62. Computer-RS232 Connectivity

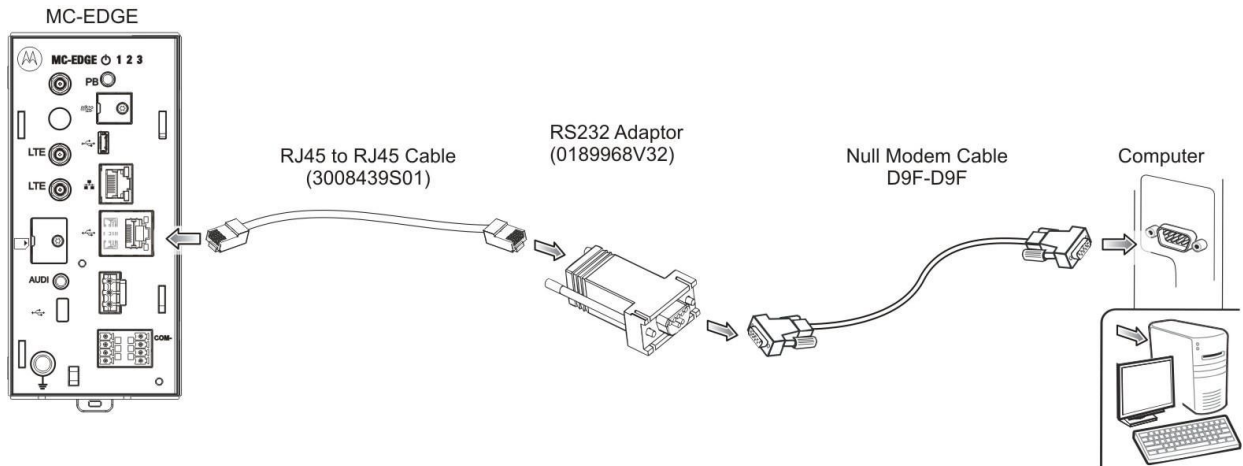

The unit port is defined as an MDLC protocol port.

The signals that appear on the male 9-pin D-type connector are according to the RS232 standard. See the following table.

Table 15. RS232-Computer Connection Pin Out

| 8-pin Connector (on RTU) | RS232 Adaptor (0189968V32) 9-pin D-type | Null Modem 9-pin Female (No flow control) | 9-pin Male (on Computer/ Terminal) |
|--------------------------|---|---|------------------------------------|
| 7 (Rx) ← | 2 | 3 | 3 (Tx) |
| 8 (Tx) → | 3 | 2 | 2 (Rx) |
| 4 (DCD) ← | 1 | NC | 7 (RTS) |
| 1 (DTR) → | 4 | NC | 8 (CTS) |
| 2 (NC) | NC (not connected) | NC | 6 (DSR) |
| 5 (GND) | 5 | 5 | 5 (GND) |
| 6 (CTS) ← | 8 | NC | 4 (DTR) |
| 3 (RTS) → | 7 | NC | 1 (DCD) |
| | NC | NC | 9 (RI) |

Connection to a Modem via RS232

Use this connection to communicate from an MC-EDGE unit over a modem.

To connect the unit's RS232 serial port to a modem, use the RS232 data cable (FKN0022), which includes an RJ45-to-RJ45 cable (3008439S01) and an adaptor (0189968V32) with a male 9-pin, D-type connector. See Figure 63.

Figure 63. RS232- Modem Connectivity

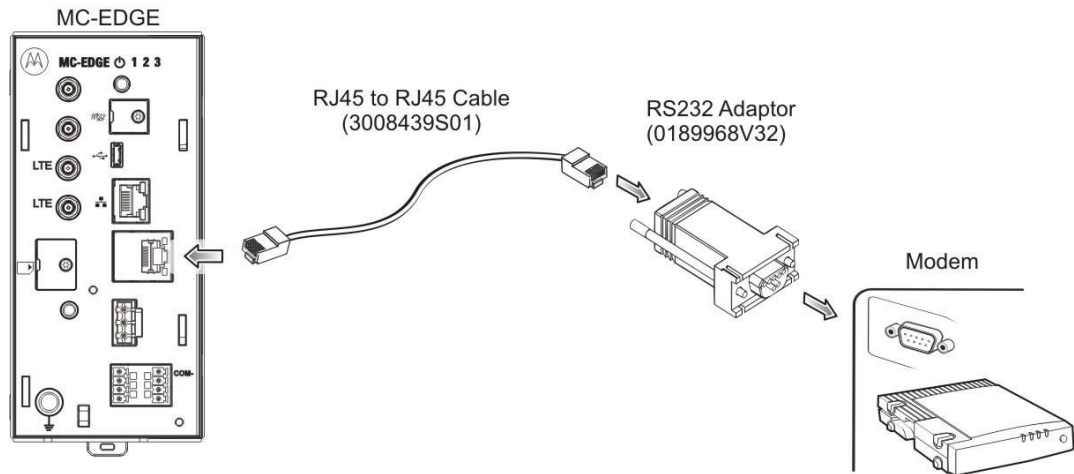

The unit port is defined as an MDLC protocol port.

The signals that appear on the male 9-pin D-type connector are according to the RS232 standard. See the following table.

Figure 64. RS232-Modem Connection Pin Out

| 8-pin Connector (on RTU) | RS232 Adaptor (0189968V32) 9-pin D-type | 9-pin Female (on Modem) |
|--------------------------|---|-------------------------|
| 7 (Rx) ← | 2 | 2 (Rx) |
| 8 (Tx) → | 3 | 3 (Tx) |
| 4 (DCD) ← | 1 | 1 (DCD) |
| 1 (DTR) → | 4 | 4 (DTR) |
| 2 (NC) | NC | 6 (DSR) |
| 5 (GND) | 5 | 5 (GND) |
| 6 (CTS) ← | 8 | 8 (CTS) |
| 3 (RTS) → | 7 | 7 (RTS) |
| | NC | 9 (RI) |

Connection to a PLC/RTU/FEP via RS232

To connect the unit's RS232 serial port to a PLC/RTU/FEP, connect an RS232 data cable (FKN0022), which includes an RJ45-to-RJ45 cable (3008439S01) and an adaptor (0189968V32) with a male 9-pin, D-type connector, to each unit. Add a null modem cable (female-to-female), which is not provided, between the two data cables. See Figure 65.

Contact Us

Figure 65. RS232-RTU/FEP Connectivity

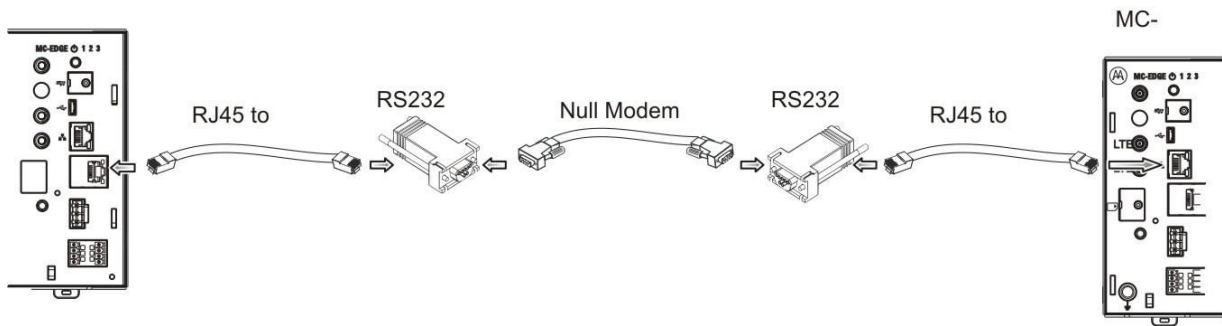
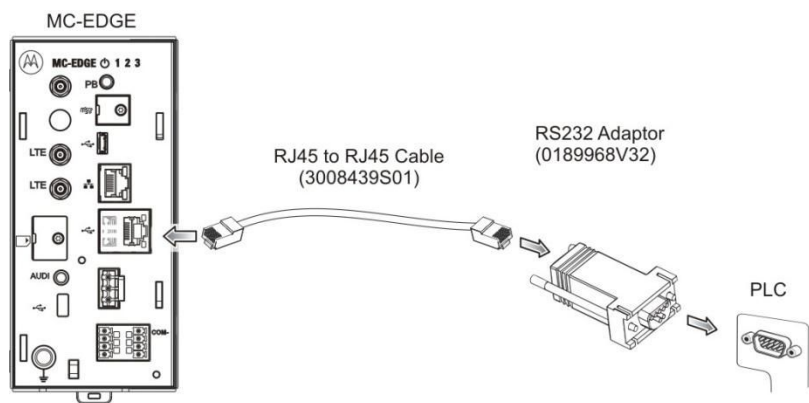

Figure 66. RS232-PLC Connectivity



The unit port is defined as an MDLC protocol port. For RS232-RTU/FEP connectivity, the port is defined as RTU-to-RTU with no flow control. Both null modem cables are supported, with or without flow control, because the FEP or RTU ignore these signals.

The signals that appear on the male 9-pin D-type connector are according to the RS232 standard. See the following tables.

Table 16. RS232-PLC/RTU/FEP Connection Pin Out without Flow Control

| 8-pin Connector (on RTU) | RS232 Adaptor (0189968V32) 9-pin D-type | Null Modem 9-pin Female (No Flow Control) | RS232 Adaptor (0189968V32) 9-pin D-type | 8-pin Connector (on RTU/FEP) |
|--------------------------|---|---|---|------------------------------|
| 7 (Rx) ← | 2 | 3 | 3 | 8 (Tx) |
| 8 (Tx) → | 3 | 2 | 2 | 7 (Rx) |
| 4 (DCD) ← | 1 | NC | 1 | 4 (DCD) |
| 1 (DTR) → | 4 | NC | 4 | 1 (DTR) |
| 2 (NC) | NC | NC | NC | 2 (NC) |
| 5 (GND) | 5 | 5 | 5 | 5 (GND) |
| 6 (CTS) ← | 8 | NC | 8 | 6 (CTS) |
| 3 (RTS) → | 7 | NC | 7 | 3 (RTS) |

| | | | | |
|--|----|----|----|--|
| | NC | NC | NC | |
|--|----|----|----|--|

Table 17. RS232-PLC/RTU/FEP Connection Pin Out with Partial Flow Control

| 8-pin Connector (on RTU) | RS232 Adaptor (0189968V32) 9-pin D-type | Null Modem 9-pin Female (with Partial Flow Control) | RS232 Adaptor (0189968V32) 9-pin D-type | 8-pin Connector (on RTU/FEP) |
|--------------------------|---|---|---|------------------------------|
| 7 (Rx) ← | 2 | 3 | 3 | 8 (Tx) |
| 8 (Tx) → | 3 | 2 | 2 | 7 (Rx) |
| 4 (DCD) ← | 1 | NC | 1 | 4 (DCD) |
| 1 (DTR) → | 4 | NC | 4 | 1 (DTR) |
| 2 (NC) | NC | NC | NC | 2 (NC) |
| 5 (GND) | 5 | 5 | 5 | 5 (GND) |
| 6 (CTS) ← | 8 | 7 | 7 | 3 (RTS) |
| 3 (RTS) → | 7 | 8 | 8 | 6 (CTS) |
| | NC | NC | NC | |

Connection to a PLC/RTU/FEP via RS485

To connect the unit's RS485 serial port to a PLC/RTU/FEP, use the RS485 adaptor cable (FKN0030A) which ends with a female 9-pin, D-type connector.

Table 18. RS485- PLC/RTU/FEP Connectivity

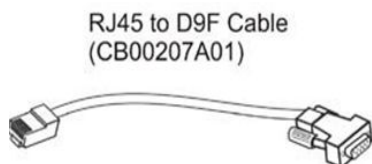

The unit port is defined as an MDLC protocol port.

The signals that appear on the female 9-pin D-type connector are according to the RS485 standard with internal 120 Ω resistance. See the following table.

Table 19. RS485-PLC/RTU/FEP Connection Pin Out

| 8-pin Connector (on RTU) | 9-pin Female on Adaptor Cable (CB00207A01) |
|--------------------------|--|
| 1 (Tx/RX+) ← | 3 (Tx/RX+) |
| 2 (NC) | 1 (NC) |
| 3 (NC) | 2 (NC) |
| 4 (NC) | 4 (NC) |
| 5 (GND) | 5 (GND) |
| 6 (NC) | 6 (NC) |

Contact Us

| | |
|--------------|------------|
| 7 (NC) | 8 (NC) |
| 8 (Tx/RX-) ← | 7 (Tx/RX-) |

Connection to a Computer (Ethernet)

Use this connection to configure an MC-EDGE mixed system using the ACE3600 STS or to configure an MC-EDGE system using the MC-EDGE Easy Configurator.

To connect the RTU LAN port to a computer via Ethernet, use a standard Ethernet cable.

In the Google Chrome™ web browser, on your computer, enter the allocated IP address of the TCP/IP port of the RTU/FEP.

If the PC/laptop does not have an appropriate local area connection for accessing the unit, do the following:

1. In Control Panel -> Network and Internet -> Network Connections, select a TCP/IP connection and click Properties.
2. If your PC/laptop is connected to the USB OTG port, click **Use the following IP address** and enter **https://192.168.9.10**. This is the address allocated to a PC/laptop communicating with the USB OTG part.
3. To use a dynamically allocated IP address, click **Obtain an IP address automatically**.
4. If you are prompted that the site's security certificate is not trusted, click **Proceed anyway**.

Connection to a Computer (USB OTG)

Use this connection to configure an MC-EDGE mixed system using the ACE3600 STS or to configure an MC-EDGE system using the MC-EDGE Easy Configurator.

To connect the RTU USB OTG (as device) port to a computer, use a USB 2.0 cable with a Micro-B connector.

In the Google Chrome™ web browser on your computer, enter the IP address of the USB OTG port of the RTU/FEP, **https://192.168.9.9**.

5. In Control Panel -> Network and Internet -> Network Connections, select a TCP/IP connection and click Properties.
6. If your PC/laptop is connected to the USB OTG port, click **Use the following IP address** and enter **https://192.168.9.10**. This is the address allocated to a PC/laptop communicating with the USB OTG part.
7. To use a dynamically allocated IP address, click **Obtain an IP address automatically**.
8. If you are prompted that the site's security certificate is not trusted, click **Proceed anyway**.

MC-EDGE CPU to MC-EDGE I/O Expansion Module Connection

To connect the MC-EDGE CPU to an MC-EDGE I/O expansion module, or to connect one MC-EDGE I/O expansion module to another MC-EDGE I/O expansion module, use the 26 AWG RJ50 cable (#30013144001.)

Table 20. B-6 MC-EDGE CPU to MC-EDGE I/O Expansion Module Connectivity

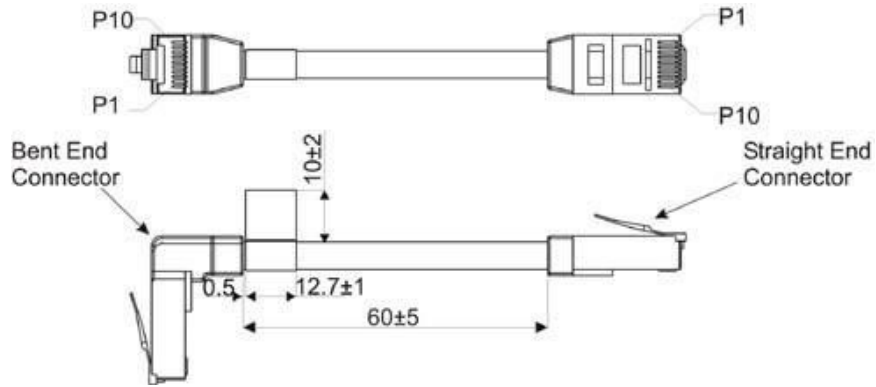

Table 21. CPU-Expansion Module Connection Pin Out

| Function | RJ50 Connector 1 | RJ50 Connector 2 |
|----------|------------------|------------------|
| GND | 1 | 1 |
| GND | 2 | 2 |
| GND | 3 | 3 |
| CAN "-" | 4 | 4 |
| CAN "+" | 5 | 5 |
| CONFIG | 6 | 6 |
| RSV | 7 | 7 |
| PWR | 8 | 8 |
| PWR | 9 | 9 |
| PWR | 10 | 10 |

Appendix C: MC-EDGE I/O References

Input /Mixed IO Module Block Diagram

Figure 67. 12 DI/8 AI – Input module 7 DI/4 AI – Mixed IO module

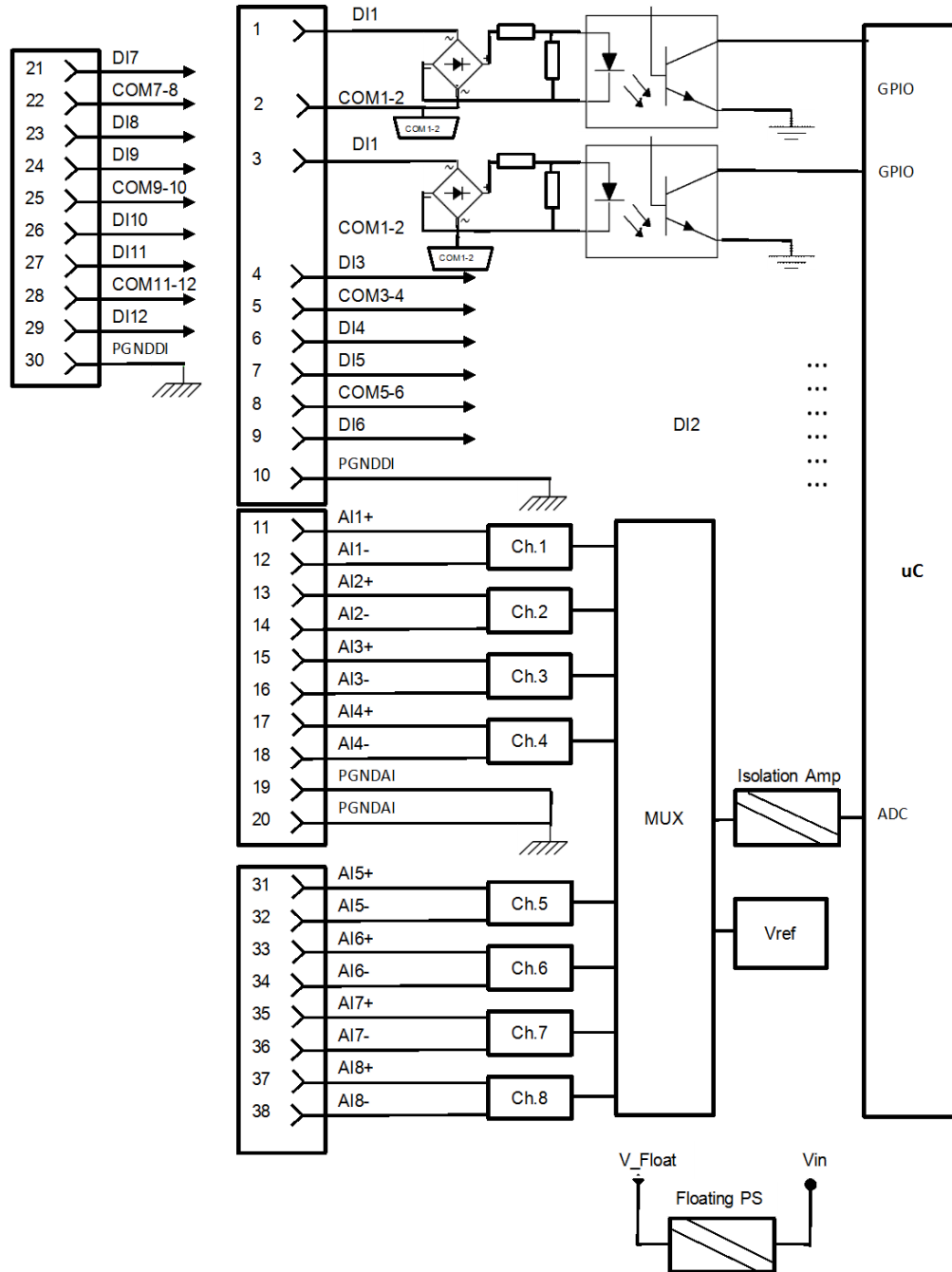

Digital Output Circuit Diagrams

Figure 68. Digital Output Circuit Diagrams

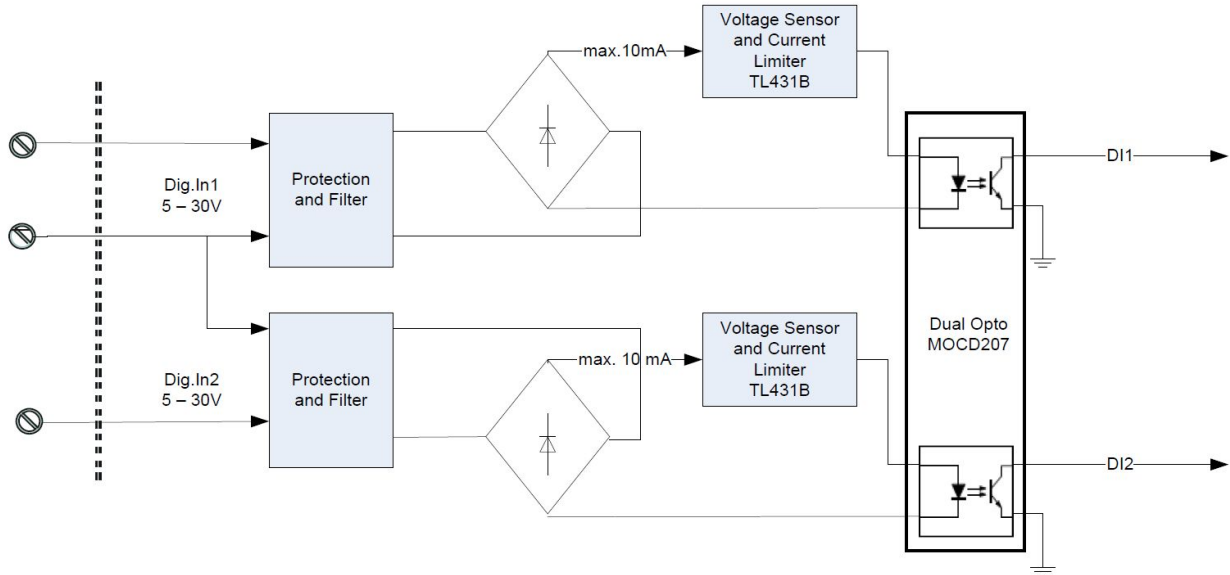

Analog Output Circuit Diagram

Figure 69. Analog Output Circuit Diagram

AI ± 5 V - Typical Input Circuit

Contact Us

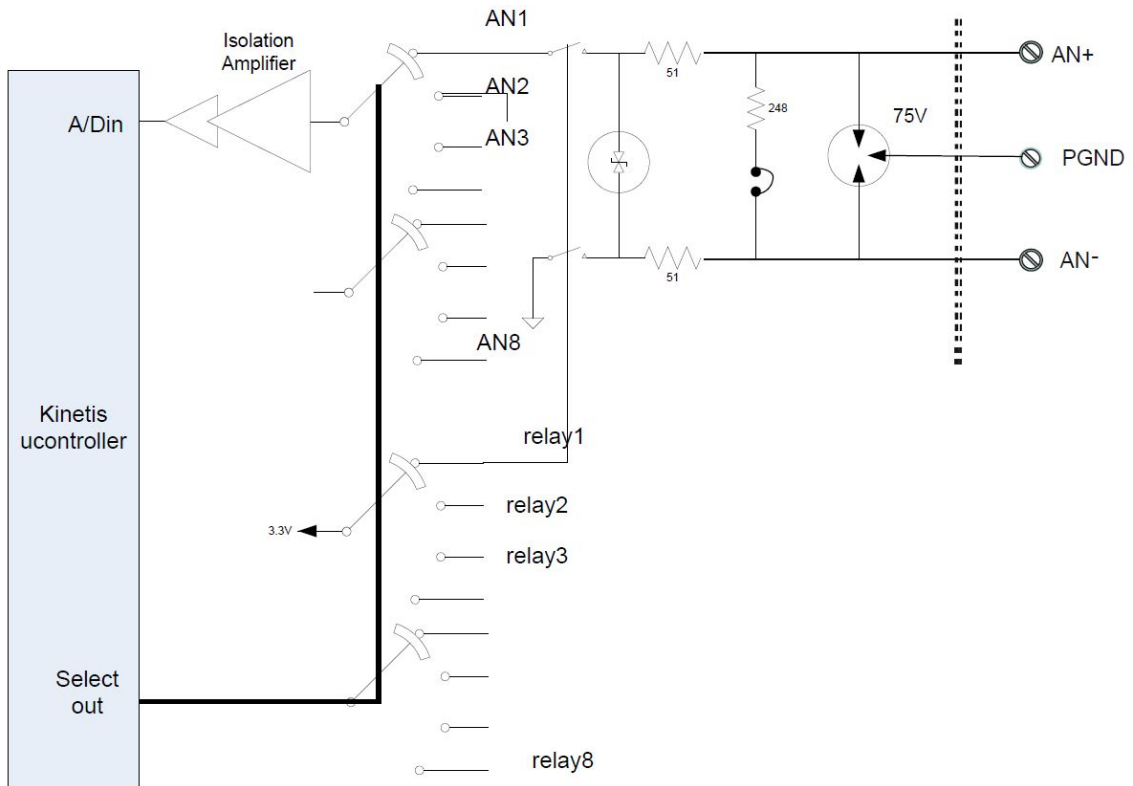

Output Module Block Diagram

Figure 70. Output Module Block Diagram

8 DO/2 AO

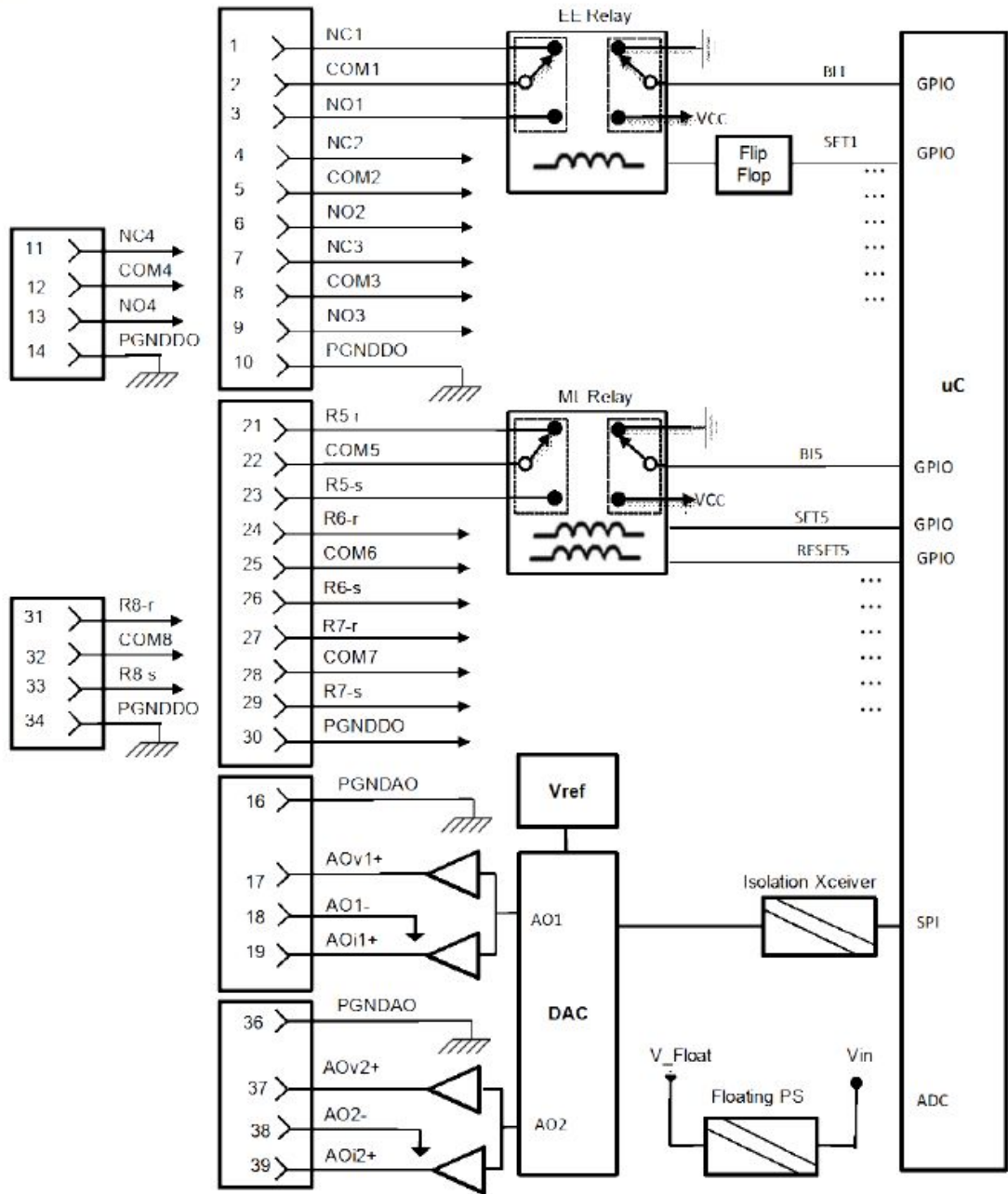

Digital Output Circuit Diagrams

Figure 71. Digital Output Circuit Diagrams

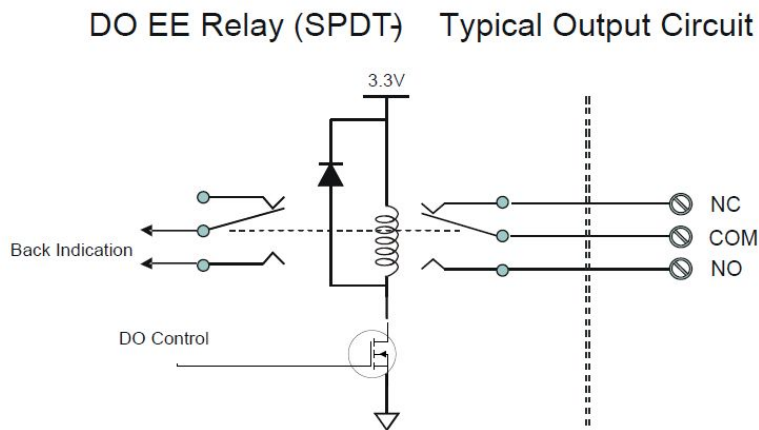
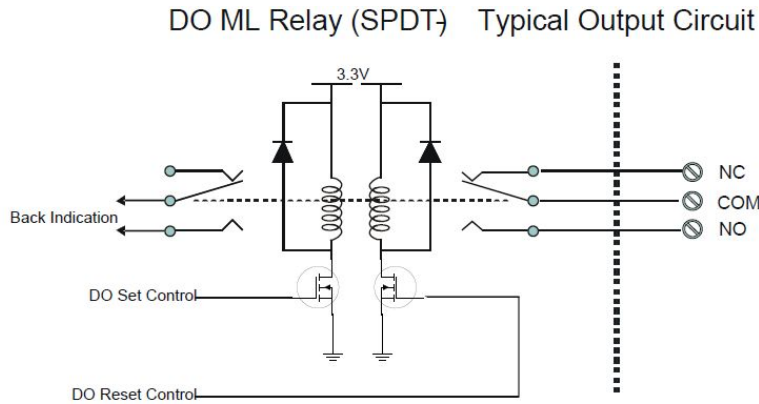

Analog Output Circuit Diagram

Figure 72. Analog Output Circuit Diagram

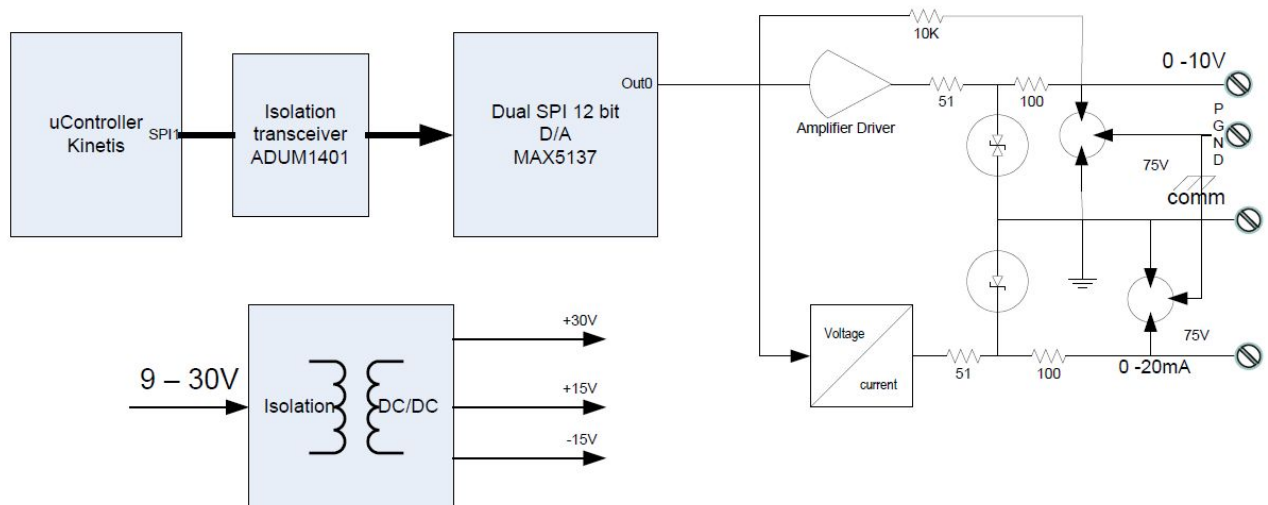

I/O Connection Charts

I/O Expansion Inputs

| Pin | Function | Pin | Function |
|---------------------|----------|-----|----------|
| Connector P3 | | | |
| 1 | DI1 | 11 | DI7 |
| 2 | COM1-2 | 12 | COM7-8 |
| 3 | DI2 | 13 | DI8 |
| 4 | DI3 | 14 | DI9 |
| 5 | COM3-4 | 15 | COM9-10 |
| 6 | DI4 | 16 | DI10 |
| 7 | DI5 | 17 | DI11 |
| 8 | COM5-6 | 18 | COM11-12 |
| 9 | DI6 | 19 | DI12 |
| 10 | PGNDDI | 20 | PGNDDI |
| Connector P4 | | | |
| 11 | AI1+ | 31 | AI5+ |
| 12 | AI1- | 32 | AI5- |
| 13 | AI2+ | 33 | AI6+ |
| 14 | AI2- | 34 | AI6- |
| 15 | AI3+ | 35 | AI7+ |
| 16 | AI3- | 36 | AI7- |
| 17 | AI4+ | 37 | AI8+ |
| 18 | AI4- | 38 | AI8- |
| 19 | PGNDAI | 39 | NC |
| 20 | PGNDAI | 40 | NC |

I/O Expansion Outputs

| Pin | Function | Pin | Function |
|---------------------|-------------------|-----|-------------------|
| Connector P3 | | | |
| 1 | NC1 | 11 | R5-r NC |
| 2 | COM1 | 12 | COM5 |
| 3 | NO1 | 13 | R5-s NO |
| 4 | NC2 | 14 | R6-r NC |
| 5 | COM2 | 15 | COM6 |
| 6 | NO2 | 16 | R6-s NO |
| 7 | NC3 | 17 | R7-r NC |
| 8 | COM3 | 18 | COM7 |
| 9 | NO3 | 19 | R7-s NO |
| 10 | PGNDDO | 30 | PGNDDO |
| Connector P4 | | | |
| 11 | NC4 | 31 | R8-r NC |
| 12 | COM4 | 32 | COM8 |
| 13 | NO4 | 33 | R8-s |
| 14 | PGNDDO | 34 | PGNDDO |
| 15 | NC | 35 | NC |
| 16 | PGNDAO | 36 | PGNDAO |
| 17 | AO _{v1+} | 37 | AO _{v2+} |
| 18 | AO1- | 38 | AO2- |
| 19 | AO _{i1+} | 39 | AO _{i2+} |
| 20 | NC | 40 | NC |

I/O Expansion Mixed IO

| Pin | Function | Pin | Function |
|---------------------|-----------------|------------|-----------------|
| Connector P3 | | | |
| 1 | R1-r | 11 | R4-r |
| 2 | COM1 | 12 | COM4 |
| 3 | R1-s | 13 | R4-s |
| 4 | NO2 | 14 | NO5 |
| 5 | COM2 | 15 | COM5 |
| 6 | NO3 | 16 | NO6 |
| 7 | COM3 | 17 | COM6 |
| 8 | PGNDDO | 18 | PGNDAI |
| 9 | AI1+ | 19 | AI3+ |
| 10 | AI1- | 20 | AI3- |
| Connector P4 | | | |
| 11 | AI2+ | 31 | AI4+ |
| 12 | AI2- | 32 | AI4- |
| 13 | VDRY | 33 | DI4 |
| 14 | COMDRY | 34 | DI5 |
| 15 | DI1 | 35 | DI6 |
| 16 | DI2 | 36 | COMDI |
| 17 | DI3 | 37 | DI7 |
| 18 | NC | 38 | PDNDDI |
| 19 | AOV+ | 39 | AOI+ |
| 20 | AO- | 40 | PGNDAO |

Appendix D: MC-EDGE External Connector Pin Outs

MC-EDGE CPU LAN Port Connector

The table below lists the pin out for the LAN (ETH1) port connector on the MC-EDGE CPU module.

Table 22. out for the LAN (ETH1) port connector on the MC-EDGE CPU module

| Pin | Direction | Description | Max Voltage | Operational Current |
|-----|-----------|-------------|--|-----------------------------------|
| 1 | OUT | TX + | 100Base-T: 1.05V differential 10Base-T: 2.8V differential | 100Base-T: 10mA 10Base-T: 30mA |
| 2 | OUT | TX - | | |
| 3 | IN | RX + | NA | NA |
| 4 | NC | NC | | |
| 5 | NC | NC | | |
| 6 | IN | RX- | NA | NA |
| 7 | NC | NC | | |
| 8 | NC | NC | | |

MC-EDGE CPU RS232 Port Connector

The table below lists the pin out for the RS232 port connector on the MC-EDGE CPU module.

 **NOTICE:** On the MC-EDGE RS232 port connector, the numbering of the pins is the opposite of that of the ACE3600 RS232 port connector.

Table 23. Pin out for the RS232 port connector on the MC-EDGE CPU module

| Pin | Direction | Description | Max Voltage | Operational Current |
|-----|-----------|-------------|-------------|---------------------|
| 1 | OUT | TX | ±5.4V | 2mA |
| 2 | IN | RX | ±12V | 4mA |
| 3 | IN | CTS | ±12V | 4mA |
| 4 | GND | GND | | |
| 5 | IN | CD | ±12V | 4mA |
| 6 | OUT | RTS | ±5.4V | 2mA |
| 7 | NC | NC | | |
| 8 | OUT | DTR/RS485 | ±5.4V | 2mA |

MC-EDGE CPU RS485 Port Connector

The table below lists the pin out for the RS485 port connector on the MC-EDGE CPU module.

Table 24. Pin out for the RS485 port connector on the MC-EDGE CPU module

| Pin | Direction | Description | Max Voltage | Operational Current |
|-----|-----------|-------------|-----------------|--------------------------|
| 1 | OUT | TX+ | 2V differential | 30mA (on 60ohm resistor) |
| 2 | NC | NC | | |
| 3 | NC | NC | | |
| 4 | NC | NC | | |
| 5 | NC | NC | | |
| 6 | NC | NC | | |
| 7 | NC | NC | | |
| 8 | OUT | TX- | 2V differential | 30mA |

MC-EDGE CPU I/O Connector

The table below lists the pin out for the I/O connector on the MC-EDGE CPU module.

Table 25. pin out for the I/O connector on the MC-EDGE CPU module

| Pin | Direction | Description | Max Voltage | Max Current |
|-----|-----------|-------------|-------------|--------------|
| 1 | I/O | R1-S | 30VDC | 2A @ 30VDC |
| 2 | I/O | COM1 | 60VDC | 0.6A @ 60VDC |
| 3 | I/O | R1-S | 30VAC | 0.6A @ 30VAC |
| 4 | PGNDDI | PGNDi | | |
| 5 | IN | COM-DI | -/+30VDC | 11mA |
| 6 | IN | DI 1 | -/+30VDC | 11mA |
| 7 | IN | DI 2 | -/+30VDC | 11mA |
| 8 | IN | DI 3 | -/+30VDC | 11mA |

MC-EDGE CPU RJ50 Connector

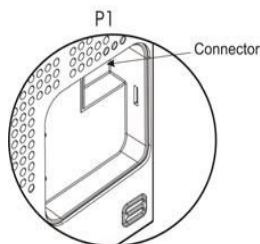

The table below lists the pin out for the RJ50 connector on the MC-EDGE CPU module.

Table 29. Pin out for the RJ50 connector on the MC-EDGE CPU module

| Pin | Direction | Description | Max Voltage | Operational Current |
|------|-----------|-------------|-----------------|------------------------------|
| 1 | GND | GND | | |
| 2 | GND | GND | | |
| 3 | GND | GND | | |
| 4, 5 | I/O | CANH, CANL | 3V differential | 50mA |
| 6 | OUT | Config | 3.6V | 0.33mA |
| 7 | NC | NC | | |
| 8 | PWR | PWR | 30V | 1A @12V (2 I/O expansion) |
| 9 | PWR | PWR | 30V | |
| 10 | PWR | PWR | 30V | |

MC-EDGE Input Module RJ50 Connector

Figure 73. MC-EDGE Input Module RJ50 Connector

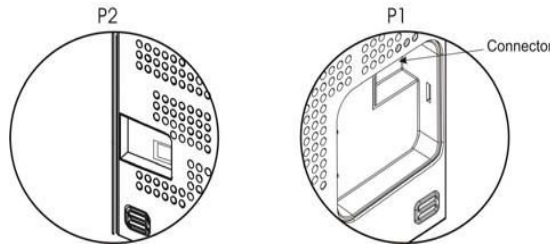

The table below lists the pin out for the P1 RJ50 Power/CAN connector on the right side of the MC-EDGE Input module.

Table 30. Pin out for the P1 RJ50 Power/CAN connector on the right side of the MC-EDGE Input module

| Pin | Direction | Description | Max Voltage | Max Current |
|-----|----------------|-------------|-------------|-------------|
| 1 | GND | Vin Ret | 30V | 1.5A |
| 2 | GND | Vin Ret | 30V | 1.5A |
| 3 | GND | Vin Ret | 30V | 1.5A |
| 4 | Bidirectional | CANL | 5V | NA |
| 5 | Bidirectional | CANH | 5V | NA |
| 6 | OUT/Open Drain | Config Out | 5V | NA |
| 7 | NC | NC | | |

Contact Us

| | | | | |
|----|--------|-----|-----|------|
| 8 | Supply | Vin | 30V | 1.5A |
| 9 | Supply | Vin | 30V | 1.5A |
| 10 | Supply | Vin | 30V | 1.5A |

The table below lists the pin out for the P2 RJ50 Power/CAN connector on the left side of the MC-EDGE Input module.

Table 31. Pin out for the P2 RJ50 Power/CAN connector on the left side of the MC-EDGE Input module

| Pin | Direction | Description | Max Voltage | Max Current |
|-----|---------------|-------------|-------------|-------------|
| 1 | GND | Vin Ret | 30V | 1.5A |
| 2 | GND | Vin Ret | 30V | 1.5A |
| 3 | GND | Vin Ret | 30V | 1.5A |
| 4 | Bidirectional | CANL | 5V | NA |
| 5 | Bidirectional | CANH | 5V | NA |
| 6 | IN | Config In | 5V | NA |
| 7 | NC | NC | | |
| 8 | Supply | Vin | 30V | 1.5A |
| 9 | Supply | Vin | 30V | 1.5A |
| 10 | Supply | Vin | 30V | 1.5A |

MC-EDGE Input Module DI Connector

The table below lists the pin out for the P3 TB Digital Input connector on the MC-EDGE Input module.

Table 32. pin out for the P3 TB Digital Input connector on the MC-EDGE Input module

| Pin | Direction | Description | Max Voltage | Max Current |
|-----|-----------|-------------|-------------|-------------|
| 1 | IN | DI1_1 | ±30V | 11mA |
| 2 | IN | DI1_2/DI2_2 | ±30V | 11mA |
| 3 | IN | DI2_1 | ±30V | 11mA |
| 4 | IN | DI3_1 | ±30V | 11mA |
| 5 | IN | DI3_2/DI4_2 | ±30V | 11mA |
| 6 | IN | DI4_1 | ±30V | 11mA |
| 7 | IN | DI5_1 | ±30V | 11mA |
| 8 | IN | DI5_2/DI6_2 | ±30V | 11mA |
| 9 | IN | DI6_1 | ±30V | 11mA |
| 10 | PGNDDI | PGND1 | N/A | N/A |

| | | | | |
|----|--------|---------------|------|------|
| 21 | IN | DI7_1 | ±30V | 11mA |
| 22 | IN | DI7_2/DI8_2 | ±30V | 11mA |
| 23 | IN | DI8_1 | ±30V | 11mA |
| 24 | IN | DI9_1 | ±30V | 11mA |
| 25 | IN | DI9_2/DI10_2 | ±30V | 11mA |
| 26 | IN | DI0_1 | ±30V | 11mA |
| 27 | IN | DI11_1 | ±30V | 11mA |
| 28 | IN | DI11_2/DI12_2 | ±30V | 11mA |
| 29 | IN | DI12_1 | ±30V | 11mA |
| 30 | PGNDDI | PGND1 | N/A | N/A |

MC-EDGE Input Module AI Connector

The table below lists the pin out for the P4 TB Analog Input connector on the MC-EDGE Input module.

Table 33. pin out for the P4 TB Analog Input connector on the MC-EDGE Input module

| Pin | Direction | Description | Max Voltage | Max Current |
|-----|-----------|-------------|-------------|-------------|
| 11 | IN | AN1_1 | ±7V | 30mA |
| 12 | IN | AN1_2 | ±7V | 30mA |
| 13 | IN | AN2_1 | ±7V | 30mA |
| 14 | IN | AN2_2 | ±7V | 30mA |
| 15 | IN | AN3_1 | ±7V | 30mA |
| 16 | IN | AN3_2 | ±7V | 30mA |
| 17 | IN | AN4_1 | ±7V | 30mA |
| 18 | IN | AN4_2 | ±7V | 30mA |
| 19 | PGNDAI | PGND2 | N/A | N/A |
| 20 | PGNDAI | PGND2 | N/A | N/A |
| 31 | IN | AN5_1 | ±7V | 30mA |
| 32 | IN | AN5_2 | ±7V | 30mA |
| 33 | IN | AN6_1 | ±7V | 30mA |
| 34 | IN | AN6_2 | ±7V | 30mA |
| 35 | IN | AN7_1 | ±7V | 30mA |
| 36 | IN | AN7_2 | ±7V | 30mA |
| 37 | IN | AN8_1 | ±7V | 30mA |
| 38 | IN | AN8_2 | ±7V | 30mA |
| 39 | NC | NC | | |

Contact Us

| | | | | |
|----|----|----|--|--|
| 40 | NC | NC | | |
|----|----|----|--|--|

MC-EDGE Output Module RJ50 Connector

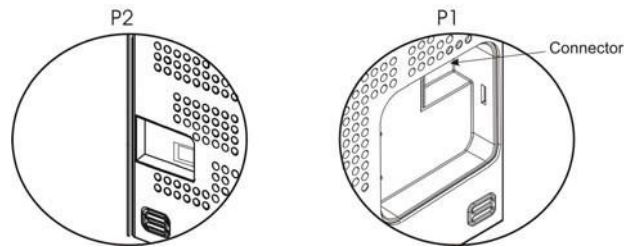

The table below lists the pin out for the P1 RJ50 Power/CAN connector on the right side of the MC-EDGE Output module.

Table 34. Pin out for the P1 RJ50 Power/CAN connector on the right side of the MC-EDGE Output module

| Pin | Direction | Description | Max Voltage | Max Current |
|-----|-----------|-------------|-------------|-------------|
| 1 | GND | GND | | 1.7A |
| 2 | GND | GND | | 1.7A |
| 3 | GND | GND | | 1.7A |
| 4 | I/O | CAN+ | 3.3V | NA |
| 5 | I/O | CAN- | 3.3V | NA |
| 6 | OUT | Config | 3.6V | NA |
| 7 | NC | NC | | |
| 8 | PWR | PWR | 30V | 1.7A |
| 9 | PWR | PWR | 30V | 1.7A |
| 10 | PWR | PWR | 30V | 1.7A |

The table below lists the pin out for the P2 RJ50 Power/CAN connector on the left side of the MC-EDGE Output module.

Table 35. Pin out for the P2 RJ50 Power/CAN connector on the left side of the MC-EDGE Output module

| Pin | Direction | Description | Max Voltage | Max Current |
|-----|-----------|-------------|-------------|-------------|
| 1 | GND | GND | | 1.7A |
| 2 | GND | GND | | 1.7A |
| 3 | GND | GND | | 1.7A |
| 4 | I/O | CANL | 3.3V | N/A |
| 5 | I/O | CANH | 3.3V | N/A |
| 6 | IN | Config | 3.6V | N/A |
| 7 | NC | NC | | |
| 8 | PWR | PWR | 30V | 1.7A |

| | | | | |
|----|-----|-----|-----|------|
| 9 | PWR | PWR | 30V | 1.7A |
| 10 | PWR | PWR | 30V | 1.7A |

MC-EDGE Output Module DO Connector

The table below lists the pin out for the P3 TB Digital Output connector on the MC-EDGE Output module.

Table 36. Pin out for the P3 TB Digital Output connector on the MC-EDGE Output module

| Pin | Direction | Description | Max Voltage | Max Current |
|-----|-----------|-------------|-------------------------|--|
| 1 | I/O | NC1 | 30VDC 60VDC 30VAC | 2A @ 30VDC 0.6A @ 60VDC 0.6A @ 30VAC |
| 2 | I/O | COM1 | | |
| 3 | I/O | NO1 | | |
| 4 | I/O | NC2 | | |
| 5 | I/O | COM2 | | |
| 6 | I/O | NO2 | | |
| 7 | I/O | NC3 | | |
| 8 | I/O | COM3 | | |
| 9 | I/O | NO3 | | |
| 10 | PGNDDO | PGNDDO | N/A | N/A |
| 21 | I/O | R5-R | 30VDC 60VDC 30VAC | 2A @ 30VDC 0.6A @ 60VDC 0.6A @ 30VAC |
| 22 | I/O | COM5 | | |
| 23 | I/O | R5-S | | |
| 24 | I/O | R6-R | | |
| 25 | I/O | COM6 | | |
| 26 | I/O | R6-S | | |
| 27 | I/O | R7-R | | |
| 28 | I/O | COM7 | | |
| 29 | I/O | R7-S | | |
| 30 | PGNDDO | PGNDDO | N/A | N/A |

MC-EDGE Output Module DO/AO Connector

The table below lists the pin out for the P4 TB Digital Output/Analog Output connector on the MC-EDGE Output module.

Table 37. Pin out for the P4 TB Digital Output/Analog Output connector on the MC-EDGE Output module

| Pin | Direction | Description | Max Voltage | Max Current |
|-----|-----------|-------------|-------------|-------------|
|-----|-----------|-------------|-------------|-------------|

Contact Us

| | | | | |
|----|--------|--------|-------------------------|--|
| 11 | I/O | NC4 | 30VDC 60VDC 30VAC | 2A @ 30VDC 0.6A @ 60VDC 0.6A @ 30VAC |
| 12 | I/O | COM4 | | |
| 13 | I/O | NO4 | | |
| 14 | PGNDDO | PGNDDO | N/A | N/A |
| 15 | NC | NC | | |
| 16 | PGNDAO | PGNDAO | N/A | N/A |
| 17 | OUT | AO1V+ | 11V | 45mA |
| 18 | OUT | AORet | 0 | 45mA |
| 19 | OUT | AO1I+ | 30V | 25Ma |
| 20 | NC | NC | | |
| 31 | I/O | R8-R | 30VDC 60VDC 30VAC | 2A @ 30VDC 0.6A @ 60VDC 0.6A @ 30VAC |
| 32 | I/O | COM8 | | |
| 33 | I/O | R8-S | | |
| 34 | PGNDDO | PGNDDO | N/A | N/A |
| 35 | NC | NC | | |
| 36 | PGNDAO | PGNDAO | N/A | N/A |
| 37 | OUT | AO2V+ | 11V | 45mA |
| 38 | OUT | AORet | 0 | 45mA |
| 39 | OUT | AO2I+ | 30V | 25mA |
| 40 | NC | NC | | |

MC-EDGE Mixed Module Connector

The table below lists the pin out for the MC-EDGE Mixed Module Connector

Table 38. Pin out for the MC-EDGE Mixed Module Connector

| Pin | Direction | Description | Max Voltage | Max Current |
|-----|-----------|-------------|-------------------------|--|
| 1 | I/O | R1-r | 30VDC 60VDC 30VAC | 2A @ 30VDC 0.6A @ 60VDC 0.6A @ 30VAC |
| 2 | I/O | COM1 | | |
| 3 | I/O | R1-s | | |
| 4 | I/O | NO2 | | |
| 5 | I/O | COM2 | | |
| 6 | I/O | NO3 | | |
| 7 | I/O | COM3 | | |
| 8 | I/O | PGNDDO | | |
| 9 | IN | AI1+ | ±7V | 30mA |

| | | | | |
|----|--------|--------|-------------------------|--|
| 10 | IN | AI1- | ±7V | 30mA |
| 21 | I/O | R4-r | 30VDC 60VDC 30VAC | 2A @ 30VDC 0.6A @ 60VDC 0.6A @ 30VAC |
| 22 | I/O | COM4 | | |
| 23 | I/O | R4-r | | |
| 24 | I/O | NO5 | | |
| 25 | I/O | COM5 | | |
| 26 | I/O | NO6 | | |
| 27 | I/O | COM6 | | |
| 28 | PGNDAI | PGNDAI | N/A | N/A |
| 29 | IN | AI3+ | ±7V | 30mA |
| 30 | IN | AI3+ | ±7V | 30mA |
| 11 | IN | AI2+ | ±7V | 30mA |
| 12 | IN | AI2+ | ±7V | 30mA |
| 13 | O | VDRY | NA | NA |
| 14 | O | COMDRY | NA | NA |
| 15 | IN | DI1 | ±30V | 11mA |
| 16 | IN | DI2 | ±30V | 11mA |
| 17 | IN | DI3 | ±30V | 11mA |
| 18 | NC | | | |
| 19 | OUT | AOV+ | 11V | 45mA |
| 20 | OUT | AO- | 0 | 45mA |
| 31 | IN | AI4+ | ±7V | 30mA |
| 32 | IN | AI4+ | ±7V | 30mA |
| 33 | IN | DI4 | ±30V | 11mA |
| 34 | IN | DI5 | ±30V | 11mA |
| 35 | IN | DI6 | ±30V | 11mA |
| 36 | IN | COMDI | ±30V | 11mA |
| 37 | IN | DI7 | ±30V | 11mA |
| 38 | PDNDDI | PDNDDI | NA | NA |
| 39 | OUT | AOI+ | 30V | 25mA |
| 40 | PGNDAO | PGNDAO | NA | NA |

Contact Us

Appendix E: MC-EDGE Field Replacement Units

MC-EDGE Field Replacement Units and Parts

The table below lists the accessories and field replacement units for the MC-EDGE RTU model (F0016A) and ACE1100 FEP/IRM1100 (F0043A).

Table 39. MC-EDGE Field Replacement Units and Parts

| Kit # | Name |
|----------|---------------------------------------|
| FKN0022 | RS-232 DATA CABLE |
| FKN0024A | TERMINAL BLOCK CONNECTOR EXTRACTOR |
| FKN0027 | MTM5200 DATA CABLE |
| FKN0030 | RS-485 PORT 120 OHM TERMINATION CABLE |
| FKN0033 | DC POWER CABLE |
| FKN0034 | GROUND CABLE |
| FLN0050A | 12DI/8AI MODULE 0-20MA |
| FLN0051A | 12DI/8AI MODULE 0-5V |
| FLN0052A | 8DO/2AO MODULE 0-20MA, 0-10V |
| FLN0116A | 7DI/6DO/4AI/1AO MODULE 0-20mA |
| FHN0054A | DIN RAIL 26 CM |
| FHN0056A | DIN RAIL 42 CM |
| FHN0057A | DIN RAIL STOPPER |
| FHN0058A | CPU CABLE COVER |
| FHN0059A | I/O MODULE CABLE COVER |
| FHN0060A | SD COVER |
| FHN0061A | TERMINAL BLOCK MALE 10 PIN 5MM |
| FHN0062A | TERMINAL BLOCK MALE 3 PIN 5 MM |
| FHN0063A | TERMINAL BLOCK MALE 2 PIN 5 MM |
| FHN0064A | TERMINAL BLOCK MALE 4 PIN 3.5MM |
| FHN0065 | RJ50 I/O MODULE CABLE |
| FLN0100A | APX 6500 INSTALLATION KIT |