



MOTOROLA

HT1250•LS⁺ User Guide







Professional Radio - As Dedicated As You Are™

CONTENTS

Computer Software Copyrights	5	Operational Cautions	12
Safety	7	Antennas	12
User Safety, Training, and		Batteries	12
General Information	7	Battery Information	12
Compliance with RF Energy Exposure		Charging Batteries	12
Standards	7	Introduction	13
Operational Instructions and Training		Trunked Radio Systems	13
Guidelines	8	PassPort™ Trunked Systems	13
Transmit and Receive	8	LTR™ Trunked Systems	13
Hand-held Radio Operation	8	Conventional Radio Systems	14
Body-worn Operation	8	HT1250•LS+ Radio Features	14
Antenna & Batteries	9	Radio Wide Features	14
Approved Accessories	9	PassPort Zone Features	14
Electromagnetic Interference/Compatibility	9	LTR Zone Features	15
Facilities	9	Conventional Zone Features	15
Aircraft	9	Radio Overview	17
Medical Devices	10	Parts of the Radio	17
Driver Safety	10	HT1250•LS+ Model	17
Operational Warnings	11	On/Off/Volume Knob	18
For Vehicles With an Air Bag	11	Zone Selector Knob	18
Potentially Explosive Atmospheres	11	LED Indicator	18
Blasting Caps and Areas	11	Push-to-Talk (PTT) Button	18
		Microphone	18
		Menu Keys	18
		Keypad Keys	19

Display	21	Call Light	
Programmable Buttons	22	(Trunked Operation Only)	38
Audio Indicators for Programmable		Home Channel Revert	39
Buttons	27	Sounding an Emergency Siren	39
Battery Information	29	To Start the Emergency Siren	39
Charging the Battery	29	To Stop the Emergency Siren	39
Getting Started	29	PASSPORT TRUNKING	41
Battery Charge Status	30	Seamless Roaming	41
Attaching the Battery	31	Initial Registration	41
Removing the Battery	31	Roaming and Registering Between	
Accessory Information	31	Sites	42
Attaching the Antenna	31	Site/MIN View	43
Removing the Antenna	32	Roam Request	43
Attaching the Belt Clip	33	To Start a Roam Request	44
Removing the Belt Clip	33	To Cancel a Roam Request	44
Attaching the Side Connector Cover	34	Site Lock	45
Turning the Radio On or Off	34	To Start Site Lock	45
Adjusting the Volume	35	To Cancel Site Lock	45
Selecting a Trunked Zone and Talkgroup	35	Troubleshooting	46
Sending a Trunked Call	36	Making a Selective Call	47
Selecting a Conventional Zone and		Radio Calls	
Channel	37	(Trunked Operation Only)	47
Sending a Conventional Call	37	Receiving a Selective Call 🎵	48
Receiving a Trunked or Conventional Call	37	Receiving a Call Alert Page	49
Repeater or Talkaround → Mode			
(Conventional Operation Only)	38		

Radio Check (LTR Trunked Operation Only)	49	To Start or Stop All Group Scan Operation through the Menu	58
Editing a Radio Call List <input type="checkbox"/>	50	System Scan  (LTR Trunked and Conventional Operation).	59
Name and Call Tone Tagging (LTR Trunked Operation Only)	51	When System Scan is Enabled	59
To Tag a Specific User's Name	52	To Start or Stop a System Scan Operation.	59
To Tag a Type of Radio Call	52	Deleting a Nuisance Channel/Talkgroup (PassPort Group Scan or System Scan Operation Only)	60
Scan	55	To Temporarily Delete the Channel/ Talkgroup	60
Talkback	55	Restoring a Channel/Talkgroup Back to the Scan List.	60
PassPort Primary Auto Group Scan	56	Editing a Scan List (PassPort Group Scan or System Scan Operation Only)	60
Passport Group Scan  (PassPort Trunked Operation Only)	56	Adding or Deleting Talkgroups or Channels in a Scan List	61
When PassPort Group Scan is Enabled	56	Prioritizing a Talkgroup or Channel in a Scan List (System Scan Operation Only).	62
To Start or Stop PassPort Group Scan Operation through a Preprogrammed Button	57	Phone.	65
To Start or Stop PassPort Group Scan Operation through the Menu.	57	Making a Phone Call  Through a Trunked System	65
Auto Group Scan  (LTR Trunked Operation Only)	57		
To Start Auto Group Scan	57		
To Stop Auto Group Scan	58		
All Group Scan  (LTR Trunked Operation Only)	58		
To Start or Stop All Group Scan Operation through the Menu	58		

Making a Phone Call ① Through a Conventional System	66	Recorded Message Delete.	78
Receiving a Phone Call ① Through a Trunked or Conventional System	68	To Delete a Message using the Preprogrammed Delete Playback Button	78
Modifying the Phone List □	69	To Delete a Message using the Menu	79
To Add an Entry.	69	Recorded Message Transmission	79
To Delete an Entry.	70	To Transmit a Recorded Message	79
To Edit an Entry.	71	Automatic Message Reply: "When Available" (LTR Trunked Operation Only).	80
Voice Storage	73	To Enable the Automatic Message Reply Feature	80
Incoming Call Recording.	74	To Disable the Automatic Message Reply Feature	81
Selective Incoming Call Recording	74	Audio/Tone Settings	83
All Incoming Call Recording	74	Utilities	85
Voice Memo Recording	76	Setting Tight or Normal Squelch (Conventional Operation Only).	88
To Record a Voice Memo using the Preprogrammed Record/Playback Button	76	Setting the Power Level LH	89
To Record a Voice Memo using the Menu	76	Setting the Clock/Alarm	90
Recorded Message Playback.	77	Warranty	91
To Play Back a Message using the Preprogrammed Record/Playback Button	77	Limited Warranty	91
To Playback a Message using the Menu	78		

Accessories	97
Carry Cases	97
Chargers	97
Headsets and Accessories	98
Microphones	99
Ear Microphone System	99
Integrated Microphone/Receiver	100
Earpiece	100
Adapters	101
Batteries	101
Antennas	101
Manuals	101

COMPUTER SOFTWARE COPYRIGHTS

The Motorola products described in this manual may include copyrighted Motorola computer programs stored in semiconductor memories or other media. Laws in the United States and other countries preserve for Motorola certain exclusive rights for copyrighted computer programs, including, but not limited to, the exclusive right to copy or reproduce in any form the copyrighted computer program. Accordingly, any copyrighted Motorola computer programs contained in the Motorola products described in this manual may not be copied, reproduced, modified, reverse-engineered, or distributed in any manner without the express written permission of Motorola. Furthermore, the purchase of Motorola products shall not be deemed to grant either directly or by implication, estoppel, or otherwise, any license under the copyrights, patents or patent applications of Motorola, except for the normal non-exclusive license to use that arises by operation of law in the sale of a product.

SAFETY

USER SAFETY, TRAINING, AND GENERAL INFORMATION

READ THIS IMPORTANT INFORMATION ON SAFE AND EFFICIENT OPERATION BEFORE USING YOUR MOTOROLA HANDHELD PORTABLE TWO-WAY RADIO

The information provided in this document supersedes the general safety information contained in user guides published prior to June 2001. For information regarding radio use in a hazardous atmosphere please refer to the Factory Mutual (FM) Approval Manual Supplement or Instruction Card, which is included with radio models that offer this capability.

COMPLIANCE WITH RF ENERGY EXPOSURE STANDARDS

Your Motorola two-way radio is designed and tested to comply with a number of national and international standards and guidelines (listed below) regarding human exposure to radio

frequency electromagnetic energy. This radio complies with the IEEE (FCC) and ICNIRP exposure limits for occupational/controlled RF exposure environment at duty cycles of up to 50% talk-50% listen and should be used for occupational use only. In terms of measuring RF energy for compliance with the FCC exposure guidelines, your radio radiates measurable RF energy only while it is transmitting (during talking), not when it is receiving (listening) or in standby mode. Note that the approved, supplied batteries for this radio are rated for a 5-5-90 duty cycle (5% talk-5% listen - 90% standby), even though this radio complies with the FCC occupational exposure limits at duty cycles of up to 50% talk.

Your Motorola two-way radio complies with the following RF energy exposure standards and guidelines:

- United States Federal Communications Commission, Code of Federal Regulations; 47CFR part 2 sub-part J
- American National Standards Institute (ANSI) / Institute of Electrical and Electronic Engineers (IEEE) C95. 1- 1992

- Institute of Electrical and Electronic Engineers (IEEE) C95.1- 1999 Edition
- International Commission on Non-Ionizing Radiation Protection (ICNIRP) 1998
- Ministry of Health (Canada) Safety Code 6. Limits of Human Exposure to Radiofrequency Electromagnetic Fields in the Frequency Range from 3 kHz to 300 GHz, 1999
- Australian Communications Authority Radiocommunications (Electromagnetic Radiation - Human Exposure) Standard 1999 (applicable to wireless phones only)
- ANATEL, Brasil Regulatory Authority, Resolution 256 (April 11, 2001) “additional requirements for SMR, cellular and PCS product certification.”

To assure optimal radio performance and make sure human exposure to radio frequency electromagnetic energy is within the guidelines set forth in the above standards, always adhere to the following procedures:

OPERATIONAL INSTRUCTIONS AND TRAINING GUIDELINES



To ensure optimal performance and compliance with the occupational/controlled environment RF energy exposure limits in the above standards and guidelines, users should transmit no more than 50% of the time and always adhere to the following procedures:

Transmit and Receive

- **To transmit (talk), push the Push-To-Talk (PTT) button; to receive, release the PTT button.**

Hand-held Radio Operation

- Hold the radio in a vertical position with the microphone one to two inches (2.5 to 5 cm) away from the lips.

Body-worn Operation

- **Always place the radio in a Motorola approved clip, holder, holster, case, or body harness for this product. Use of non-Motorola-approved accessories may exceed FCC RF exposure guidelines.**

- If you do not use a Motorola approved body-worn accessory and are not using the radio in the intended use position in front of the face, then ensure the antenna and the radio are kept 2.5 cm (one inch) from the body when transmitting.

Antenna & Batteries

- **Use only Motorola approved supplied antenna or Motorola approved replacement antenna.** Unauthorized antennas, modifications, or attachments could damage the radio and may violate FCC regulations.
- **Use only Motorola approved, supplied batteries or Motorola approved replacement batteries.** Use of non-Motorola-approved antennas or batteries may exceed FCC RF exposure guidelines.

Approved Accessories

For a list of approved Motorola accessories see the accessory section of this User Guide.

ELECTROMAGNETIC INTERFERENCE/COMPATIBILITY

Note: Nearly every electronic device is susceptible to electromagnetic interference (EMI) if inadequately shielded, designed, or otherwise configured for electromagnetic compatibility.

Facilities

To avoid electromagnetic interference and/or compatibility conflicts, turn off your radio in any facility where posted notices instruct you to do so. Hospitals or health care facilities may be using equipment that is sensitive to external RF energy.

Aircraft

When instructed to do so, turn off your radio when on board an aircraft. Any use of a radio must be in accordance with applicable regulations per airline crew instructions.

Medical Devices

- **Pacemakers**

The Advanced Medical Technology Association (AdvaMed) recommends that a minimum separation of 6 inches (15 centimeters) be maintained between a handheld wireless radio and a pacemaker. These recommendations are consistent with those of the U. S. Food and Drug Administration.

Persons with pacemakers should:

- ALWAYS keep the radio more than 6 inches (15 centimeters) from their pacemaker when the radio is turned ON.
- not carry the radio in the breast pocket.
- use the ear opposite the pacemaker to minimize the potential for interference.
- turn the radio OFF immediately if you have any reason to suspect that interference is taking place.

- **Hearing Aids**

Some digital wireless radios may interfere with some hearing aids. In the event of such interference, you may want to consult your

hearing aid manufacturer to discuss alternatives.

- **Other Medical Devices**

If you use any other personal medical device, consult the manufacturer of your device to determine if it is adequately shielded from RF energy. Your physician may be able to assist you in obtaining this information.

Driver Safety

Check the laws and regulations on the use of radios in the area where you drive. Always obey them.

When using your radio while driving, please:

- Give full attention to driving and to the road.
- Use hands-free operation, if available.
- Pull off the road and park before making or answering a call if driving conditions so require.

OPERATIONAL WARNINGS



WARNING

For Vehicles With an Air Bag

Do not place a portable radio in the area over an air bag or in the air bag deployment area. Air bags inflate with great force. If a portable radio is placed in the air bag deployment area and the air bag inflates, the radio may be propelled with great force and cause serious injury to occupants of the vehicle.

Potentially Explosive Atmospheres

Turn off your radio prior to entering any area with a potentially explosive atmosphere, unless it is a radio type especially qualified for use in such areas as “Intrinsically Safe” (for example, Factory Mutual, CSA, UL, or CENELEC). Do not remove, install, or charge batteries in such areas. Sparks in a potentially explosive atmosphere can cause an explosion or fire resulting in bodily injury or even death.

The areas with potentially explosive atmospheres referred to above include fueling areas such as below decks on boats, fuel or chemical transfer or storage facilities, areas where the air contains chemicals or particles, such as grain, dust or metal powders, and any other area where you would normally be advised to turn off your vehicle engine. Areas with potentially explosive atmospheres are often but not always posted.

Blasting Caps and Areas

To avoid possible interference with blasting operations, turn off your radio when you are near electrical blasting caps, in a blasting area, or in areas posted: “Turn off two-way radio.” Obey all signs and instructions.

OPERATIONAL CAUTIONS



Caution

Antennas

Do not use any portable radio that has a damaged antenna. If a damaged antenna comes into contact with your skin, a minor burn can result.

Batteries

All batteries can cause property damage and/or bodily injury such as burns if a conductive material such as jewelry, keys, or beaded chains touch exposed terminals. The conductive material may complete an electrical circuit (short circuit) and become quite hot. Exercise care in handling any charged battery, particularly when placing it inside a pocket, purse, or other container with metal objects.

BATTERY INFORMATION

Charging Batteries

This product is powered by a nickel-metal-hydride (NiMH), or lithium-ion rechargeable battery. Charge the battery before use to ensure optimum capacity and performance. The battery was designed specifically to be used with a Motorola charger. Charging in non-Motorola equipment may lead to battery damage and void the battery warranty.

Note: When charging a battery attached to a radio, turn the radio off to ensure a full charge.

The battery should be at about 77°F (25°C) (room temperature), whenever possible. Charging a cold battery (below 50° F [10°C]) may result in leakage of electrolyte and ultimately in failure of the battery. Charging a hot battery (above 95°F [35°C]) results in reduced discharge capacity, affecting the performance of the radio. Motorola rapid-rate battery chargers contain a temperature-sensing circuit to ensure that batteries are charged within the temperature limits stated above.

INTRODUCTION



Welcome to Motorola's HT Series family of radio users. The HT1250•LS⁺, the Intelligent Radio, combines the very latest in two-way technology while delivering outstanding functionality

at the touch of a button.

The HT1250•LS⁺ portable radio operates on PassPort and LTR trunked and conventional radio systems.

TRUNKED RADIO SYSTEMS

Trunked systems allow a large number of users to share a relatively small number of frequencies or repeaters without interfering with each other. The airtime of all the repeaters in a trunked system is pooled, which maximizes the amount of airtime available to any one radio and minimizes channel congestion.

PassPort™ Trunked Systems

PassPort is an enhanced trunking protocol developed by Trident Micro Systems that supports wide area dispatch networking. A network is formed by linking several trunked sites together to form a single system. This offers users an extended communication coverage area. Additionally, users with PassPort can seamlessly roam among all sites within the network. Seamless roaming means that the radio user does not have to manually change the zones on the radio when roaming from site-to-site.

LTR™ Trunked Systems

LTR is a transmission based trunking protocol developed by the E. F. Johnson Company for primarily single site trunking applications. In transmission trunking, a repeater is used for only the duration of a single transmission. Once a transmission is completed, that repeater becomes available to other users. This means that a conversation comprised of many transmissions may occur over several different channels within the LTR system. This method of trunking provides system efficiency

by making repeaters available to all users after every transmission.

CONVENTIONAL RADIO SYSTEMS

Conventional radio systems typically refers to unit-to-unit communications through a single channel. Conventional systems also allow radio users to extend communication coverage by relaying their messages through a repeater. To ensure coordinated use by multiple talkgroups, each radio user must monitor the channel or repeater before transmitting to verify that the system is not currently busy.

HT1250•LS+ RADIO FEATURES

Note: Throughout this manual there are features listed as trunked and conventional. **Trunked** indicates the feature functions in both PassPort and LTR zones unless otherwise noted. **Conventional** indicates the feature functions in Conventional zones only.

HT1250•LS+ Portable Feature Highlights:

Radio Wide Features

- 14-Character Alphanumeric Display
- 7 Programmable Feature Buttons
- Up to 15 PassPort and/or LTR Zones with up to 16 Talkgroups per Zone
- Up to 16 Conventional Channels
- X-Pand Audio Enhancement Selectable by Conventional Channel, LTR repeater or PassPort Talkgroup
- Home Channel Revert
- Telephone Interconnect
- User-programmable Phone and Scan Lists
- Voice Storage Capability

PassPort Zone Features

- Unique Mobile Identity Number per radio
- Unique Electronic Serial Number per radio
- Registration/Deregistration upon power up/power down
- Automatic Seamless Roaming Between Networked Sites
- Registered Site and Mobile Identity View
- User Initiated Roam Request
- PassPort Primary Group Auto Scan and Passport Scan
- PTT ID (Display of Mobile Identification Number)

PassPort Zone Features (Cont.)

- Call Signalling Features
 - Call Alert
 - Selective Call
- Site Lock

LTR Zone Features

- MDC 1200 Signaling
 - Call Alert
 - Radio Check
 - Selective Call
 - Caller ID
- Auto Group System, All Group Scan
- System Scan with 2 Priority Levels

Conventional Zone Features

- Monitor and Sticky Permanent Monitor
- System Scan with 2 priority levels

Notes

RADIO OVERVIEW

PARTS OF THE RADIO

HT1250•LS⁺ Model

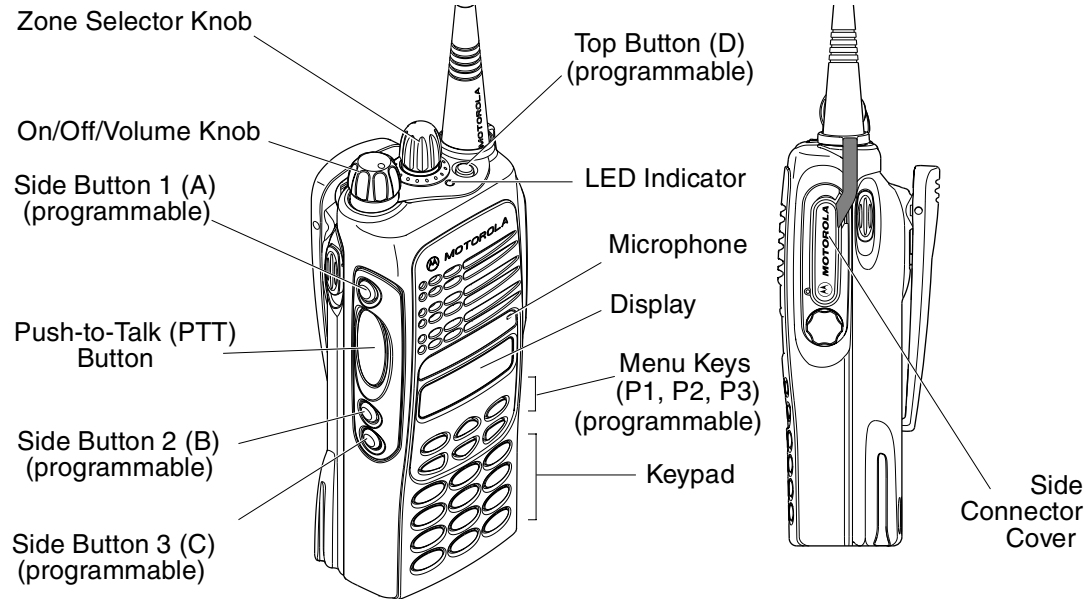

On/Off/Volume Knob

Turns the radio on or off, and adjusts the radio's volume.

Zone Selector Knob

Switches the radio to different LTR trunked and conventional zones. It is also used to scroll through menu choices when in Menu Mode.

LED Indicator

Indicates battery status (see page 30); or the status of power-up, scan, or receipt of a talkgroup or selective call (see table below):

LED Color	Indicates
Steady red	Radio is transmitting (PTT button pressed)
Flashing red	Radio is attempting to access trunked system (PTT button pressed), or Radio is receiving (PTT button released)
Single flashing yellow	Call Light feature, or Individual Selective Call Received (LTR trunked only)

LED Color	Indicates
Double flashing yellow	Group Selective call received (LTR trunked only)
Momentary green	Radio has powered-up successfully
Double flashing green	System or All Group Scan operation, PassPort Group Scan

Push-to-Talk (PTT) Button

Press and hold down this button to talk; release it to listen.

Microphone

When sending a message, hold the microphone 1 to 2 inches (2.5 to 5 cm) away from your mouth, and speak clearly into the microphone.

Menu Keys

Exit



Left

Up



Down

Menu/Select



Right



Menu/Select Key

Used to enter menu mode. When in menu mode, this key is also used to make menu selections.

Exit Key

Used to move to the previous menu level (short press) or to exit menu mode (long press).

Up Key

- Used to scroll through the preprogrammed talkgroups of a selected trunked zone, or through conventional channels when in conventional zone.
- Used for scrolling when in menu mode.
- The **P2** key can also be programmed with a radio feature (see page 22).

Right Key

Moves the cursor right or inserts a space when editing call, scan, and phone lists. This key can also be programmed with a radio feature (see page 22).

Left Key

Used as a backspace key when editing radio call, scan, and phone lists. This key can also be programmed with a radio feature (see page 22).

Keypad Keys

These keys are used for:

- Dialing a phone number
- Entering a specific radio ID number when making a selective call or call alert
- Entering information when programming radio call, scan, and phone lists

Each key can generate several different characters. For example, to enter the character “C,” press the key three times. (Refer to the following table.)



Entering Characters Using the Keypad



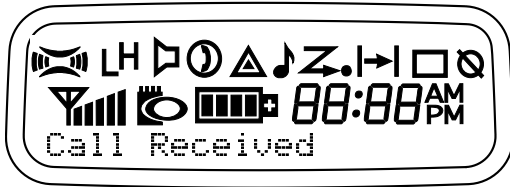

Key	Number of Times Key is Pressed														
	1	2	3	4	5	6	7	8	9	10	11	12	13	14	15
0	0	()	< >												
1	1	&	%	#	*										
2 abc	A	B	C	2	a	b	c	2	Á	Ç	à	á	ç		
3 def	D	E	F	3	d	e	f	3	È	É	Ê	è	é	ê	
4 ghi	G	H	I	4	g	h	i	4	Í	Ì	Í				
5 jkl	J	K	L	5	j	k	l	5							
6 mno	M	N	O	6	m	n	o	6	Ñ	Ó	Ô	ò	ó	ô	ö
7 pqrs	P	Q	R	S	7	p	q	r	s	7					
8 tuv	T	U	V	8	t	u	v	8	Ú	Ù	Ú				
9 wxyz	W	X	Y	Z	9	w	x	y	z	9	Ý	ý			
*	*	/	+	-	=										
#	#	Blank Space	-	.	!	?	'	”	,	;	:				





Display





The top two screen rows display menu and radio status information:

Symbol	Indication
 X-Pand	The X-Pand feature is activated. When in narrow band, this feature improves audio quality.
LH Power Level	Low Power “L” or High Power “H” is activated.
 Monitor	The selected channel is being monitored (conventional operation only).
 Phone	Phone mode is selected.

Symbol	Indication
 Emergency	An Emergency Siren is being sounded.
 Call Received	A Selective Call or Call Alert has been received (LTR trunked operation only).
 Scan	When the green LED is blinking, indicates that the System, PassPort Scan, or All Group Scan feature has been activated. When the green LED is off, indicates that non-prioritized Auto Group Scan has been activated.
 •Priority 1 Scan (● flashing)	Indicates activity on a priority 1 talkgroup or channel during System Scan.

Symbol	Indication
 Priority 2 Scan (● steady)	<ul style="list-style-type: none"> When the green LED is on, indicates activity on a priority 2 talkgroup or channel during System Scan. When the green LED is off, indicates prioritized Auto Group Scan has been activated.
 Talkaround	You are not transmitting through a repeater (Conventional operation only).
 Programming Mode	A Program list is being edited.
 Keypad Lock	Keypad is locked.
 Battery Level	The number of bars (0–4) shown indicates the charge remaining in your battery.

Symbol	Indication
 Clock	Shows the time (12- or 24-hour).
 Signal Strength	The more bars, the stronger the signal being received by your radio.
 PassPort Zone	A PassPort zone has been selected.

Programmable Buttons

Several of your radio's buttons can be programmed by your dealer as shortcuts to many of the radio's features.

Programmable buttons include:

- The Three Side Buttons (A, B, C) and the Top Button (D)
- The Three Lower Menu Keys (P1, P2, P3) (when the radio is not in menu mode)

Each button can access up to two features, depending on the type of button press:

- **Short Press**—quickly pressing and releasing the programmable buttons,
or
- **Long Press**—pressing and holding the programmable buttons for a period of time (programmable for 1/2 to 1 1/2 seconds),
or
- **Hold Down**—pressing and holding down the programmable buttons while checking status or making adjustments.

The table on page 24 summarizes the programmable features available and shows the page number where the feature is explained.

In the “Button” column, have your dealer write down the programmable buttons next to the features that have been programmed to them.

Use the abbreviations (for example, A for Side Button 1, D for Top Button, etc.) shown in the radio illustration at the front of this manual.

Also, where a choice exists, have your dealer indicate whether the button press is short press (SP) or long press (LP).

Check with your dealer for a complete list of features your radio supports.

Programmable Features

Feature	Indicator	Short Press	Long Press	Hold Down	Page	Button
Battery Gauge	LED Color	—	—	Check the battery's charge status.	30	
Emergency Siren (Top button only)	▲	Initiate Emergency Siren.	Cancel Emergency Siren.	—	39	
Home Channel Revert	—	Directly access your favorite trunked zone and talkgroup or conventional channel.†		—	39	
Keypad Lock	Ⓚ	—	Toggle keypad between locked and unlocked.	—	—	
Light	—	Turn on your radio backlight.†		—	—	
Monitor §	▶	Exit permanent monitor mode.	Enter permanent monitor mode.	Continually monitor channel	—	
Phone	Ⓣ	Directly access Phone mode.†		—	66	
Power Level	LH	Toggle transmit power level between high and low.†		—	88	
Radio Call ‡	LED Color	Directly access radio call menu.†		—	47	

† This feature is activated by **EITHER** a short **OR** a long press, but not both.

§ Conventional operation only. ‡LTR trunked operation only. *PassPort trunked operation only.

Programmable Features (Continued)

Feature	Indicator	Short Press	Long Press	Hold Down	Page	Button
Repeater/ Talkaround §	→	Toggle between using a conventional repeater or transmitting directly to another radio.†		—	38	
Roam Request*	Searching	Manually initiate PassPort roaming function.†	Stop PassPort roaming function.	—	43	
Scan/Delete Nuisance Channel	↯	Turn PassPort Group, All Group, and System scan on or off.	Delete a nuisance channel while scanning.	—	60	
Site/MIN View*	—	Displays the PassPort site number on which the unit is registered, the home site and unit's MIN (Mobile Identity Number).†		—	43	
Speed Dial	—	Quickly access speed dial phone list.†		—	67	
Squelch§	—	Toggle squelch level between tight and normal.†		—	88	
Site Lock	Locked	Directly access "Home Site Lock" or "Current Site Lock" options.		—		

† This feature is activated by **EITHER** a short **OR** a long press, but not both.

§ Conventional operation only. ‡ LTR trunked operation only. *PassPort trunked operation only.

Programmable Features (Continued)

Feature	Indicator	Short Press	Long Press	Hold Down	Page	Button
Voice Storage Record/Playback	—	Playback recorded messages.	Record voice memos.	—	77	
Voice Storage Playback Exit	—	Exit Voice Storage Play Back mode.†		—	77	
Voice Storage Playback Delete	—	Delete recorded messages.†		—	78	
Volume Set	—	—	—	Sound a tone for adjusting your radio's volume level.	35	
Edit Scan List	—	Add, Delete, or prioritize talkgroups or channels.			60	

† This feature is activated by **EITHER** a short **OR** a long press, but not both.

§ Conventional operation only. ‡ LTR trunked operation only. *PassPort trunked operation only.

AUDIO INDICATORS FOR PROGRAMMABLE BUTTONS

In addition to having visual indicators, some programmable buttons use tones to indicate one of two modes:



High-Low Tone



Low-High Tone

Button	High-Low Tone	Low-High Tone
Scan	Stop scan	Start scan
Power Level	High power selected	Low power selected
Squelch (no visual indicator)	Normal squelch	Tight squelch
Keypad Lock	Unlocked	Locked
Repeater/Talkaround	Uses conventional repeater	Does not use conventional repeater

Notes

GETTING STARTED

BATTERY INFORMATION

Charging the Battery

If a battery is new or its charge level is very low, you need to charge it before you can use it.

Note: Batteries are shipped uncharged from the factory. Always charge a new battery 14 to 16 hours before initial use, regardless of the status indicated by the charger.

To charge the battery:

Place the battery, with or without the radio, in the charger. The charger LED indicates the charging progress:

LED Color	Battery/Charger Status
No LED Indication	Battery inserted incorrectly.
Single Green Flash	Successful charger power-up.
Flashing Red*	Battery unchargeable or not making proper contact.
Steady Red	Battery in rapid-charge mode.
Flashing Yellow	Battery in charger, not in rapid-charge mode but waiting to be charged.
Flashing Green†	Battery 90% (or more) charged.
Steady Green	Battery fully charged.







* Remove the battery from the charger. Clean battery contacts with isopropyl alcohol applied to a soft cloth. Place the battery back in the charger. If the LED indicator continues to flash red, replace the battery.

† A standard battery may require one hour to charge to 90%.

Battery Charge Status

You can check your battery's charge status in two ways:

- The charge status is shown by the  status indicator symbol on the display. This does not require any action by you; the symbol is shown automatically.
- Hold down the preprogrammed **Battery LED Indicator** button (see page 22). The charge status is shown by the color of the radio's LED indicator.

Battery Level	LED Indicator	Status Indicator 
High	Green	
Sufficient	Yellow	 or 
Low	Flashing red	
Very Low	None	 (flashing)

Battery charges will only charge the Motorola-authorized batteries listed below; other batteries may not charge.

Part No.	Description
HNN9008	1200 mAh NiMH High Capacity Battery (standard)
HNN9009	1900 mAh NiMH Ultra High Capacity Battery
HNN9010	1850 mAh NiMH, Ultra High Capacity - Factory Mutual
HNN9011	1200 mAh Ni-Cad, High Capacity Battery - Factory Mutual
HNN9012	1350 mAh Ni-Cad High Capacity Battery
HNN9013	1200 mAh Lithium Ion Battery

Attaching the Battery

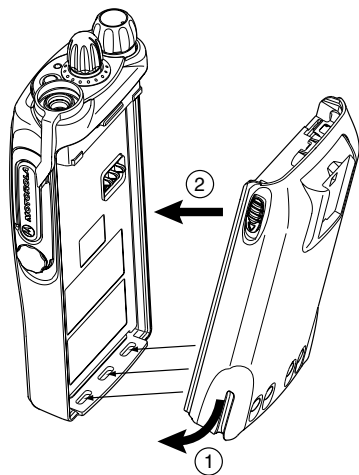

- 1 Fit the extensions at the bottom of the battery into the bottom slots on the radio.
- 2 Press the top part of the battery toward the radio until you hear a click.

Removing the Battery

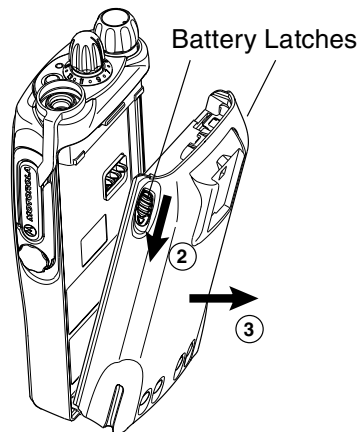

- 1 Turn off the radio (see page 34).
- 2 Slide both battery latches downward.
- 3 Pull the top part of the battery away from the radio.

ACCESSORY INFORMATION

Attaching the Antenna

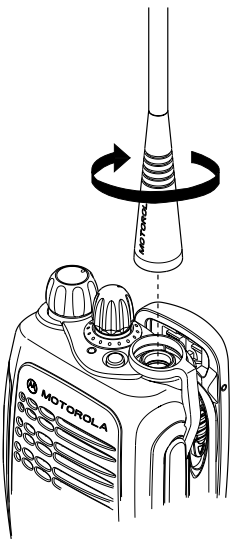

1 Turn the antenna clockwise to attach it.

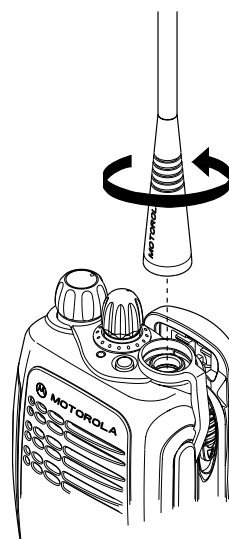

1 Turn the antenna clockwise to remove it.

Removing the Antenna

Attaching the Belt Clip

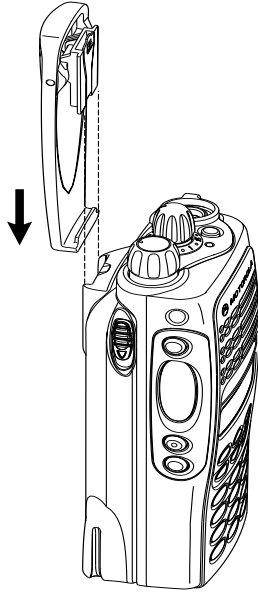

- 1 Align the grooves of the belt clip with those of the battery.
- 2 Press the belt clip downward until you hear a click.

Removing the Belt Clip

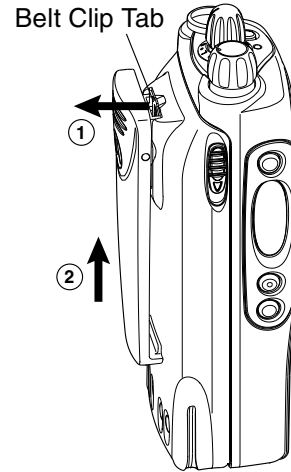

- 1 Use a key to press the belt clip tab away from the battery.
- 2 Slide the belt clip upward to remove it.

Attaching the Side Connector Cover

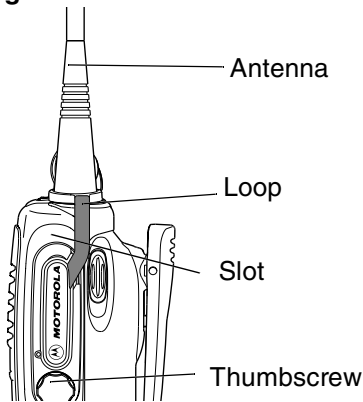

- 1 Place the loop (attached to the side connector cover) over the antenna; then slide it downward until it touches the top of the radio.
- 2 Insert the tab on the top of the cover into the slot above the connector.
- 3 Position the cover over the connector and align the thumbscrew with the threaded hole in the radio.
- 4 Tighten the thumbscrew to hold the cover in place. **Do not overtighten the thumbscrew.**

TURNING THE RADIO ON OR OFF

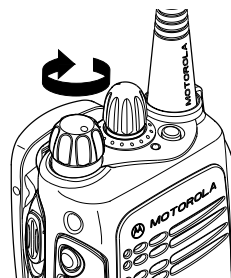

ON

Turn the **On/Off/Volume** knob clockwise.

If power-up is successful, you hear the Self-Test Pass Tone



and see the LED momentarily turn green.

If the radio fails to power up, you hear the Self-Test Fail Tone .

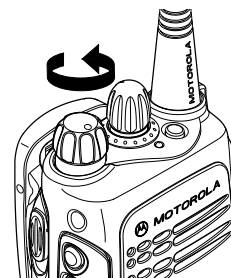

OFF

Turn the **On/Off/Volume** knob counterclockwise until you hear a click.

ADJUSTING THE VOLUME

Turn the **On-Off/Volume Control** knob clockwise to increase the volume or counterclockwise to decrease the volume.

—or—



- 1 Hold down the **Volume Set** button (see this page); you hear a continuous tone.
- 2 Turn the **On-Off/Volume Control** knob to the desired volume level.
- 3 Release the **Volume Set** button.

SELECTING A TRUNKED ZONE AND TALKGROUP

Note: Throughout this manual there are features listed as trunked and conventional. **Trunked** indicates the feature functions in both PassPort and LTR zones unless otherwise noted. **Conventional** indicates the feature functions in Conventional zones only.

Up to 15 PassPort and/or LTR trunked zones (containing 16 talkgroups each) can be programmed into your radio.

To select a trunked zone and talkgroup:

- 1 Use the **Zone Selector** knob to select the appropriate trunked Zone.
- 2  or  until you see the desired preprogrammed talkgroup on the display

Note:  (the PassPort Zone symbol) appears when a PassPort Zone has been selected.

SENDING A TRUNKED CALL

To send a trunked call:

- 1 Hold the radio in a vertical position at a distance of about 1 to 2 inches (2.5 to 5 cm) from your mouth.





- 2 Press and hold the **PTT** button.
–or–
Press and release the **PTT** button and wait 3 seconds.
 - If access to the trunked system was successful, the LED indicator lights steady red.
 - In addition, your dealer can program your radio to sound a short, high-pitched (talk permit) tone, indicating successful trunked system access.
 - If access to the trunked system was unsuccessful, the LED indicator flashes red and a low-pitched (talk prohibit) tone sounds, indicating that the system was busy or out-of-range.

- 3 With the **PTT** button depressed, speak clearly into the microphone.

- 4 Release the **PTT** button to listen.
-

SELECTING A CONVENTIONAL ZONE AND CHANNEL

- 1 Use the **Zone Selector** knob to select the appropriate conventional zone.
- 2  or  until you see the desired conventional channel on the display.

SENDING A CONVENTIONAL CALL

Note: In the United States, FCC regulations require you to monitor the conventional channels before sending a call. The monitor feature (see page 22) can be accessed through one of your programmable buttons.

- 1 Hold the radio in a vertical position at a distance of about 1 to 2 inches (2.5 to 5 cm) from your mouth.



- 2 Press the **PTT** button and speak clearly into the microphone. The LED indicator lights steady red while the call is being sent.
- 3 Release the **PTT** button to listen.

RECEIVING A TRUNKED OR CONVENTIONAL CALL

- 1 Turn your radio on.
- 2 Adjust your radio's volume (see page 35).
- 3 Use the **Zone Selector** knob to select the desired trunked or conventional zone.
 - Make sure the **PTT** button is released.
- 4 Listen for voice activity. The LED indicator flashes red when your radio is receiving.

Note: In PassPort mode,  the Mobile Identity Number (XXXX) of the calling radio appears on the display if enabled.

REPEATER OR TALKAROUND |→| MODE

(CONVENTIONAL OPERATION ONLY)

Talkaround mode enables you to communicate with another radio when either:

- The repeater is not operating
–or–
- Your radio is out of the repeater's range but within communicating distance of another radio.



Note: The |→| symbol appears on the display when talkaround mode is selected.

To Select Repeater Mode or Talkaround Mode

Press the preprogrammed **Repeater/Talkaround** button (see page 22) to toggle between repeater mode and talkaround mode.

–or–



1  to enter menu mode.

2  or  until

Rptr/Talkarnd

3  to select

Rptr/Talkarnd

4  or  until

Rptr/Talkarnd

–or– until

Talkarnd Mode

5  to confirm your selection.

CALL LIGHT

(TRUNKED OPERATION ONLY)

The **Call Light** indicator informs you that you have received a call from a specified talkgroup (as programmed by your dealer). The yellow LED indicator will flash continuously, indicating that a trunked call has been received.

To Turn the Call Light Off

- Press the **PTT** button.
- Select another trunked or conventional zone.
- Press any preprogrammed button.
- Turn the radio off, then on again.

HOME CHANNEL REVERT

The Home Channel Revert feature allows you to instantly access your favorite trunked

talkgroup or conventional channel at the touch of a button.

To Activate Home Channel Revert

Press the preprogrammed **Home Channel Revert** button (see page 26).

SOUNDING AN EMERGENCY SIREN

In the event of an emergency, you may need to quickly get the attention of others for help. The Emergency Siren feature (if programmed by your dealer) causes your radio to emit a continuous, high-pitched tone.

Note: The  symbol appears on the display when the Emergency Siren has been activated.

To Start the Emergency Siren

Press the preprogrammed **Emergency Siren** button (see page 26).

To Stop the Emergency Siren

Press the **Emergency Siren** button again or press the **PTT** button.

Notes

PASSPORT TRUNKING

PassPort is an enhanced, wide-area trunking protocol developed by Trident Micro Systems. Up to 128 trunked sites can be linked together to form one PassPort system, which means that your communications can extend far beyond the reach of a single trunked site.

SEAMLESS ROAMING

Passport Trunking systems offer you the ability to seamlessly roam among all sites in a network. Seamless Roaming means that you do not have to manually change the zones on the radio when roaming from site-to-site. As you roam throughout a Passport System's coverage area, your HT1250•LS⁺ radio is regularly monitoring the RSSI (Received Signal Strength Indication) level of the site on which you are currently registered. In addition, if the signal strength falls below the acceptable threshold pre-programmed by your dealer, your radio starts monitoring the RSSI level of adjacent sites within the network. This allows the HT1250•LS⁺ radio to quickly roam to the site with the strongest signal, which provides

you with optimal audio quality throughout your communications.

Initial Registration

Before communications with your talkgroup can begin, your radio needs to register on the PassPort system. Registration automatically takes place upon radio power up or after selecting the desired PassPort zone on the selector knob. What you see:

- 1 Upon radio Power up, you see:
(if you select a PassPort zone after the radio is powered up, see step 2).

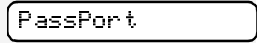

PassPort

- 2 The selected **PassPort zone alias** appears on the display.
- 3 The selected **Talk-group Alias** appears on the display.

Note: If the radio performs a more extensive frequency search in order to attempt successful registration, you may see:

SEARCHING

- 4 Upon successful PassPort Registration, you see:

REG SITE XXX

Note: Your radio sounds a “Low-High” tone upon successful PassPort System registration. The XXX number indicates the site within the PassPort system on which you have registered.

- 5 After successfully registering at a site, the selected PassPort talkgroup alias appears and remains on the display.

YOUR TLKGRP ALIAS

Roaming and Registering Between Sites

Once initial registration with the PassPort system has occurred, your radio constantly monitors the RSSI to ensure an acceptable signal level is maintained (as programmed by your dealer). When the RSSI in the radio falls below this acceptable level, the HT1250•LS⁺ attempts to roam to and register onto another site within the PassPort system.

This process happens automatically and requires no action by you. What you see:

- 1 When the radio is searching for a new site or attempting successful registration to a site, you see:

SEARCHING

Note: This message is displayed until successful registration.

- 2 When the radio has successfully registered to the new PassPort System, XXX indicates the site number you see:

REG SITE XXX

- The selected Pass-Port talkgroup alias appears and remains on the display.

TLKGRP ALIAS

SITE/MIN VIEW

There may be circumstances when you want to view the number of the PassPort site on which you are registered as well as your Mobile Identity Number (MIN).

To Start and Stop Viewing Site/MIN

- Press the preprogrammed **SITE/MIN View** button (see page 22).

The display shows the number of the site on which you are currently registered.

site now XXX

Note: If the preprogrammed button is activated prior to or during registration, a bad key chirp is sounded and you see:

site now n/a

The display indicates the Home site number (ASID) and Mobile Identity Number. XXX indicates the ASID, YYYYY indicates the MIN.

IAM XXX-YYYYY

Note: This message can be activated if the radio is not registered.

ROAM REQUEST

Because of the RSSI feature, the HT1250•LS+ radio automatically roams to a different site when the signal from the registered site becomes too weak for quality communication. This RSSI threshold is programmed by your dealer. However, if you believe the signal strength would be better on another site, you may want to manually initiate the roaming process. This feature is called Roam Request.

To Start a Roam Request

1 Press the preprogrammed **Roam Request** button (see page 22).

2 When the radio is searching for a new site or attempting successful registration to a site, you see:

A rectangular display box with rounded corners containing the word "SEARCHING" in a monospaced font.

3 When the radio has successfully registered to the new PassPort System, you see:

A rectangular display box with rounded corners containing the text "REG SITE XXX" in a monospaced font.

Note: A bad key chirp may sound and you see:

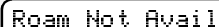
A rectangular display box with rounded corners containing the text "Roam Not Avail" in a monospaced font.

- When registration to a site with a higher RSSI than your current site is unavailable.
- When the preprogrammed button is pressed before the radio has collected its “neighbor list”. A Neighborlist” is a list of frequencies from adjoining sites within the PassPort system that are used during the roam process.
- When the radio is programmed for a single home system.

In these cases, wait a few seconds and try again.

4 The selected Pass-Port talkgroup alias appears and remains on the display:

A rectangular display box with rounded corners containing the text "TLKGRP ALIAS" in a monospaced font.

To Cancel a Roam Request

1 Press and hold the preprogrammed **Roam Request** button (see page 25) again.

You see

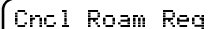
A rectangular display box with rounded corners containing the text "Cnc1 Roam Req" in a monospaced font.

Note: The radio then attempts to return to the previously registered site.

SITE LOCK



Because of the RSSI (Received Signal Strength Indication) feature, the HT1250•LS⁺ radio automatically roams to a different site when the signal falls below the RSSI level programmed in your radio by your dealer. In some instances (inside a building or in fringe areas), you may want to prevent your radio from roaming. This is possible by enabling the Site Lock functions.

To Start Site Lock

- 1 Press the preprogrammed **Site Lock** button (see page 25).

You see:

Home Site Lock

- 2  or  until

Home Site Lock

–or–

Current Site Lock

- 3 Press the preprogrammed **Site Lock** button again to make your selection.

Note: If Home Site Lock is selected, your radio reverts and locks onto your home site.
If Current Site Lock is selected, your radio reverts and locks onto the site that currently has the strongest RSSI level.

- 4 The site name and number appear on the display.

You see:

Site Name & No.

–or–

Locked

To Cancel Site Lock

Turn off your radio or change zones/talkgroups to cancel the Site Lock feature. Your radio automatically re-registers on the PassPort system.

TROUBLESHOOTING

While in PassPort zones, there are some specific display messages that indicate you should contact your dealer for assistance.

Message	What it Means
“Invalid Group ID”	Your dealer needs to verify talk-group programming in your radio or the PassPort system.
“DISABLED”	Your radio requires reactivation on the PassPort system (not applicable to conventional and LTR functionality).
Blank display upon power up with a full charged battery.	Your radio needs to be returned to your dealer for reactivation or service.

RADIO CALLS

(TRUNKED OPERATION ONLY)

MAKING A SELECTIVE CALL



You can make a selective call to a particular radio or group or radios, as programmed by your dealer.

To Make a Selective Call

Press the preprogrammed Radio Call button (see page 24), and proceed to step 4.

–or–



1  to enter menu mode.

2  or  until

Radio Call

3  to select



Radio Call

4  or  until

Selective Call

5  to select

Selective Call

6  or  to locate the desired ID in the Radio Call List.

–or–

Enter the ID number of the radio you want to call. (Full keypad model only.)

7 Press the **PTT** button to send the call.

- The radio sounds a continuous tone, if programmed by your dealer.
- The LED lights a solid yellow.

8 Press the **PTT** button and talk; release the **PTT** button to listen.

If not received, you see:

No Acknowledge

9  to return to

Selective Call

–or–

Hold down  to exit menu mode.

RECEIVING A SELECTIVE CALL 🎵

When you Receive a Selective Call

- The display shows 🎵 the preprogrammed name or ID of the calling radio.
- The LED indicator flashes yellow, if programmed by your dealer.
- You hear an alert tone.

To answer the call, press the **PTT** button.

Note: In LTR trunked mode, unless you make a Selective Call back to the caller, your response is heard by all members of your talkgroup.



SENDING A CALL ALERT PAGE

You can alert another person by sending a Call Alert page.

To Send a Call Alert Page

Press the preprogrammed Radio Call button (see page 26) and proceed to step 4:



1  to enter menu mode.

2  or  until

Radio Call

3  to select



Radio Call

4  or  until

Call Alert

5  to select

Call Alert

6  or  to locate the desired ID in the Radio Call List.

–or–

Enter the ID number of the radio you want to page.

7 Press the **PTT** button.

You see:

Call In Prog

and the preprogrammed name or ID alternating on the display.

- The LED alternates between a solid yellow and solid red while the call is in process.

- 8 If the Call Alert page is received by the target radio, you see:

Acknowledge

If not received, you see:

No Acknowledge

- The radio sounds a short alert tone if, programmed by your dealer.

- 9  to return to

Call Alert

–or–

Hold down  to exit menu mode.

RECEIVING A CALL ALERT PAGE

When you Receive a Call Alert Page

- The display shows  Call Received and the preprogrammed name or ID of the calling radio.

- You hear four alert tones, either once or continuously, as programmed by your dealer.
- The LED indicator flashes a single yellow for a group call, or flashes a double yellow for an individual call.











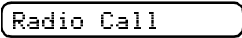

To answer the page, press the **PTT** button; to cancel the page, press any other key.

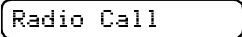
Note: Your radio displays only the last Call Alert page received. Also, your radio does not receive any Selective Calls until you clear the page.

RADIO CHECK (LTR TRUNKED OPERATION ONLY)

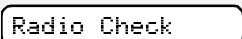
Radio Check allows you to determine if a radio is within the range of the trunked system and turned on, without disturbing the user of that radio. This feature can also be used when attempts with Selective Call and Call Alert fail.

To Perform a Radio Check

- 1  to enter menu mode.
- 2  or  until 
- 3  to select 
- 4  or  until 
- 5  to select 
- 6  or  to locate the desired ID in the Radio Call list
 -or-
 Enter the ID number of the radio you are checking.
- 7 Press the **PTT** button.
 You see: 

- 8 If the Radio Check is received by the target radio, you see:

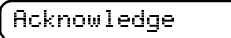

If not received, you see:

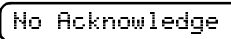

- 9 (to return to

-or-

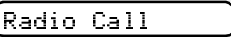

Hold down (to exit menu mode.

EDITING A RADIO CALL LIST K

Your radio has a Radio Call list that contains the names and radio IDs of several talkgroups or individuals. The ID numbers in the Radio Call List are programmed by your dealer, and cannot be changed from your radio. However, you can edit the names associated with these IDs. The  symbol appears on the display when you are editing.

Note: The radio cannot receive any calls while you are editing.

To Edit a Call List Entry



1  to enter menu mode.

2  or  until

Program Lists

3  to select

Program Lists

4  or  until

RadioCall List

5  to select



RadioCall List

6  or  until

Edit Entry?

7  to select

Edit Entry?

8  or  until you locate the desired entry.

9  to select the entry.

10 Use your keypad to edit the entry (page 19).

11  to save your changes.

Edit Entry?

12  to return to

Edit Entry?

–or–

Hold down  to exit menu mode.















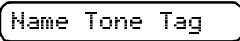

NAME AND CALL TONE TAGGING (LTR TRUNKED OPERATION ONLY)

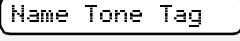
You can program your radio to sound a particular alert tone when a specific user is calling (name tone tagging), or when receiving a particular type of radio call (call tone tagging).

Note: Name and call tone tagging are valid only for selective calls and call alerts.

There are seven alert tones to select from. (See table, page page 84.)

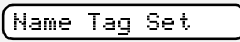

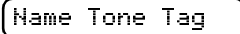









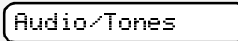

To Tag a Specific User's Name

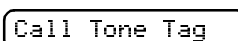
- 1  to enter menu mode.
- 2 + or  until 
- 3  to select 
- 4  or  until 
- 5  to select 
- 6  or  until you see the name you want to tag.
- 7  to confirm the selection.
- 8  or  until you see and hear the tone you want to use for this name.
- 9  to confirm the selection.
You see: 
- 10  to return to 

-or-

Hold down  to exit menu mode.

To Tag a Type of Radio Call

- 1  to enter menu mode.
- 2  or  until 
- 3  to select 
- 4  or  until 
- 5  to select 
- 6  or  until you see the call type you want to tag.
- 7  to confirm the selection.
- 8  or  until you see and hear the tone you want to use for this type of call.
- 9  to confirm the selection.

You see:

Call Tone Set

10  to return to

Call Tone Tag

—or—

Hold down  to exit menu mode.

Notes