

Professional Digital Two-Way Radio System

MOTOTRBO™ XPR 4500 / XPR 4550 Display Mobile

User Guide



Declaration of Conformity

Declaration of Conformity

This declaration is applicable to your radio *only* if your radio is labeled with the FCC logo shown below.

DECLARATION OF CONFORMITY

Per FCC CFR 47 Part 2 Section 2.1077(a)



Responsible Party
Name: Motorola, Inc.

Address: 1301 East Algonquin Road, Schaumburg, IL 60196-1078, U.S.A.
Phone Number: 1-888-567-7347

Hereby declares that the product:

Model Name: **XPR 4500/XPR 4550**

conforms to the following regulations:

FCC Part 15, subpart B, section 15.107(a), 15.107(d) and section 15.109(a)

Class B Digital Device

As a personal computer peripheral, this device complies with Part 15 of the FCC Rules. Operation is subject to the following two conditions:

1. This device may not cause harmful interference, and
2. This device must accept any interference received, including interference that may cause undesired operation.

Note: This equipment has been tested and found to comply with the limits for a Class B digital device, pursuant to part 15 of the FCC Rules. These limits are designed to provide reasonable protection against harmful interference in a residential installation. This equipment generates, uses and can radiate radio frequency energy and, if not installed and used in accordance with the instructions, may cause harmful interference to radio communications. However, there is no guarantee that interference will not occur in a particular installation.

If this equipment does cause harmful interference to radio or television reception, which can be determined by turning the equipment off and on, the user is encouraged to try to correct the interference by one or more of the following measures:

- Reorient or relocate the receiving antenna.
- Increase the separation between the equipment and receiver.
- Connect the equipment into an outlet on a circuit different from that to which the receiver is connected.
- Consult the dealer or an experienced radio/TV technician for help.

Contents

This User Guide contains all the information you need to use the MOTOTRBO XPR Series Digital Mobile Radios.

Declaration of Conformity	i
Important Safety Information	vii
Product Safety and RF Exposure Compliance ..	vii
Computer Software Copyrights	viii
Getting Started	1
How to Use This User Guide	1
What Your Dealer/System Administrator Can Tell You	1
Powering Up the Radio	2
Adjusting the Volume	2
Identifying Radio Controls	3
Radio Controls You Will Be Using	3
Programmable Buttons	4
Assignable Radio Functions	4
Assignable Settings/Utility Functions	5
Accessing the Programmed Functions	5
Push-To-Talk (PTT) Button	6
Switching Between Analog and Digital Mode	6

Identifying Status Indicators	7
Display Icons	7
Call Icons	8
Sent Item Icons	8
LED Indicators	9
Audio Tones	9
Receiving and Making Calls	10
Selecting a Zone	10
Selecting a Radio Channel, Subscriber Alias or ID, or Group Alias or ID	11
Receiving and Responding to a Radio Call	11
Receiving and Responding to a Group Call	12
Receiving and Responding to a Private Call	12
Receiving an All Call	13
Making a Radio Call	14
Making a Call with the Channel Rocker	14
Making a Group Call	14
Making a Private Call	15
Making an All Call	16
Making a Group or Private Call with the One Touch Call Button	16
Talkaround	17
Permanent Monitor	17



Advanced Features	18	Activating and Deactivating Call Ringers for Text Messaging	28
Radio Check	18	Assigning Ring Styles	28
Sending a Radio Check	18	Escalating Alarm Tone Volume	29
Remote Monitor	19	Call Log Features	29
Initiating Remote Monitor	19	Viewing Recent Calls	29
Scan Lists	21	Missed Call Screen	30
Viewing an Entry in the Scan List	21	Deleting a Call from a Call List	30
Editing the Scan List	21	Call Alert Operation	31
Adding a New Entry to the Scan List	21	Receiving and Acknowledging a Call Alert	31
Deleting an Entry from the Scan List	22	Making a Call Alert from the Contacts List	31
Setting and Editing Priority for an Entry in the Scan List	22	Making a Call Alert with the One Touch Call Button	32
Scan	23	Emergency Operation	32
Starting and Stopping Scan	23	Receiving an Emergency Alarm	33
Responding to a Transmission During a Scan	24	Responding to an Emergency Alarm	33
Deleting a Nuisance Channel	24	Sending an Emergency Alarm	34
Restoring a Nuisance Channel	25	Sending an Emergency Alarm with Call	34
Contacts Settings	25	Sending an Emergency Alarm with Voice to Follow	35
Making a Group Call from Contacts	26	Reinitiating an Emergency Mode	36
Making a Private Call from Contacts	26	Exiting Emergency Mode	36
Call Indicator Settings	27	Text Messaging Features	37
Activating and Deactivating Call Ringers for Private Calls	27	Sending a Quick Text Message	37

Contents

Sending a Quick Text Message with the One Touch Call Button	37
Managing Fail-to-Send Text Messages	38
Resending a Text Message	38
Forwarding a Text Message	38
Managing Sent Text Messages	39
Viewing a Sent Text Message	39
Sending a Sent Text Message	39
Deleting All Sent Text Messages from Sent Items	40
Receiving a Text Message	41
Reading a Text Message	41
Managing Received Text Messages	41
Viewing a Text Message from the Inbox	42
Replying to a Text Message with Quick Text	42
Deleting a Text Message from the Inbox	43
Deleting All Text Messages from the Inbox	44
Privacy	44
Security	45
Radio Disable	45
Radio Enable	46
Utilities	47
Setting the Squelch Level	47
Setting the Power Level	48
Turning the Option Board Feature(s) On or Off	48
Turning the Public Address System On or Off	48
Turning the External Public Address System On or Off	48
Controlling the Display Backlight	49
Turning Horns/Lights On or Off	49
Turning Radio Tones/Alerts On or Off	50
Turning the Talk Permit Tone On or Off	50
Turning the LED Indicators On or Off	50
Turning the Introduction Screen On or Off	51
Accessing General Radio Information	51
Checking the Radio ID	51
Checking the Firmware Version	52
Checking the Codeplug Version	52
Keypad Microphone Features	52
Using the Keypad	53
Turning Keypad Tones On or Off	54
Additional Advanced Features	54
Initiating a Radio Check by Manual Dial	54
Initiating Remote Monitor by Manual Dial	55
Making a Private Call by Manual Dial	56

Making a Private Call by Alias Search	56
Storing an Alias or ID from the Missed Call List	57
Making a Call Alert by Manual Dial	58
Text Messaging	58
Writing and Sending a Text Message	58
Replying to Text Messages from the Inbox	59
Editing a Quick Text Message	60
Managing Fail-to-Send Text Messages	61
Forwarding a Text Message by Manual Dial	61
Editing a Text Message	61
Security	62
Radio Disable via Manual Dial	62
Radio Enable via Manual Dial	62
Accessories	63
Antennas	63
Audio	64
Cables	64
Desktop Accessories	64
Mounting Kits	65
Speakers	65
Miscellaneous Accessories	65
Limited Warranty	66

----- Important Safety Information

Product Safety and RF Exposure Compliance



Before using this product, read the operating instructions for safe usage contained in the Product Safety and RF Exposure booklet enclosed with your radio.

Caution

ATTENTION!

This radio is restricted to occupational use only to satisfy FCC RF energy exposure requirements. Before using this product, read the RF energy awareness information and operating instructions in the Product Safety and RF Exposure booklet enclosed with your radio (Motorola Publication part number 6881095C99_) to ensure compliance with RF energy exposure limits.

For a list of Motorola-approved antennas and other accessories, visit the following website:

<http://www.motorola.com/governmentandenterprise>

Computer Software Copyrights

The Motorola products described in this manual may include copyrighted Motorola computer programs stored in semiconductor memories or other media. Laws in the United States and other countries preserve for Motorola certain exclusive rights for copyrighted computer programs including, but not limited to, the exclusive right to copy or reproduce in any form the copyrighted computer program. Accordingly, any copyrighted Motorola computer programs contained in the Motorola products described in this manual may not be copied, reproduced, modified, reverse-engineered, or distributed in any manner without the express written permission of Motorola. Furthermore, the purchase of Motorola products shall not be deemed to grant either directly or by implication, estoppel, or otherwise, any license under the copyrights, patents or patent applications of Motorola, except for the normal non-exclusive license to use that arises by operation of law in the sale of a product.

The AMBE+2™ voice coding Technology embodied in this product is protected by intellectual property rights including patent rights, copyrights and trade secrets of Digital Voice Systems, Inc.

This voice coding Technology is licensed solely for use within this Communications Equipment. The user of this Technology is explicitly prohibited from attempting to decompile, reverse engineer, or disassemble the Object Code, or in any other way convert the Object Code into a human-readable form.

U.S. Pat. Nos. #5,870,405, #5,826,222, #5,754,974, #5,701,390, #5,715,365, #5,649,050, #5,630,011, #5,581,656, #5,517,511, #5,491,772, #5,247,579, #5,226,084 and #5,195,166.

Getting Started

Take a moment to review the following:

- How to Use This User Guide. page 1
- What Your Dealer/System Administrator Can Tell You . page 1
- Powering Up the Radio page 2
- Adjusting the Volume. page 2

How to Use This User Guide

This User Guide covers the basic operation of the MOTOTRBO Mobiles.

However, your dealer or system administrator may have customized your radio for your specific needs. Check with your dealer or system administrator for more information.

Throughout this publication, two icons are used to differentiate Analog mode and Digital mode only features:



Indicates an Analog Mode only feature.



Indicates a Digital Mode only feature.

For features that are available in both Analog and Digital modes, no icon is shown.

What Your Dealer/System Administrator Can Tell You

You can consult your dealer or system administrator about the following:

- Is your radio programmed with any preset conventional channels?
- Which buttons have been programmed to access other features?
- What optional accessories may suit your needs?

■ Powering Up the Radio

Press the On/Off Button briefly. You see Motorola and MOTOTRBO (™) on the radio's display momentarily, followed by Motorola once more.

The green LED blinks and the Home screen lights up if the backlight setting is set to turn on automatically.

NOTE: The Home screen does not light up during a power up if the LED indicators are disabled (see **Turning the LED Indicators On or Off** on page 50).

A brief tone sounds, indicating that the power up test is successful.

NOTE: There is no power up tone if the radio tones/alerts function is disabled (see **Turning Radio Tones/Alerts On or Off** on page 50).

If your radio does not power up, contact your dealer.

To turn off the radio, press and hold the On/Off Button until you see *Powering Down* on the radio's display.

■ Adjusting the Volume

To increase the volume, turn the **Volume Knob** clockwise.

To decrease the volume, turn this knob counterclockwise.

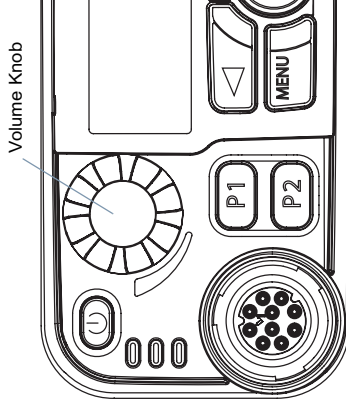

Identifying Radio Controls

Take a moment to review the following:

Radio Controls You Will Be Using	page 3
Programmable Buttons	page 4
Accessing the Programmed Functions	page 5
Push-To-Talk (PTT) Button	page 6
Switching Between Analog and Digital Mode	page 6

Radio Controls You Will Be Using

- 1 On/Off Button
- 2 Volume Knob
- 3 Front Button P1*
- 4 Display
- 5 Channel Rocker
- 6 Speaker
- 7 Front Button P3*
- 8 Front Button P4*
- 9 Menu Navigation Buttons
- 10 Front Button P2*
- 11 Accessory Connector
- 12 LED Indicators

* These buttons are programmable.

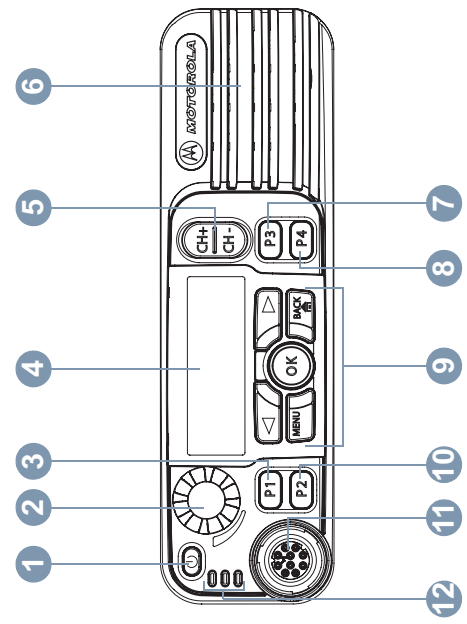

■ Programmable Buttons

Your dealer can program the programmable buttons as shortcuts to radio functions or preset channels/groups depending on the duration of a button press:

- Press – Pressing and releasing rapidly.
- Long press – Pressing and holding for the programmed duration (between 0.25 seconds and 3.75 seconds).
- Hold down – Keeping the button pressed.

📄 Assignable Radio Functions

Contacts – Provides direct access to the Contacts list.

Emergency – Depending on the programming, initiates or cancels an emergency alarm or call.

Ext PA On/Off – Toggles the audio routing between the connected public address (PA) loudspeaker amplifier and the radio's internal public address (PA) system.

Manual Dial  – Initiates a call by keying in any subscriber ID. Only available with a keypad microphone.

Nuisance Channel Delete  – Temporarily removes an unwanted channel, except for the Selected Channel, from the scan list. The Selected Channel refers to the user's selected zone/channel combination from which scan is initiated.

One Touch Call  – Directly initiates a predefined Group or Private Call, a Call Alert or a Quick Text message.

Option Board Feature  – Toggles option board features on or off for option board-enabled channels.

PA On/Off  – Toggles the radio's internal public address (PA) system on or off.







Permanent Monitor  – Monitors a selected channel for all radio traffic until function is disabled.

Privacy  – Toggles privacy on or off.





Radio Check  – Determines if a radio is active in a system.

Radio Enable  – Allows a target radio to be remotely enabled.

Radio Disable  – Allows a target radio to be remotely disabled.

- Remote Monitor**  – Turns on the microphone of a target radio without it giving any indicators.
- Repeater/Talkaround**  – Toggles between using a repeater and communicating directly with another radio.
- Scan**  – Toggles scan on or off.
- Telemetry Control**  – Controls the Output Pin on a local or remote radio.
- Text Message**  – Selects the text message menu.
- Zone**  – Allows selection from a list of zones.

Assignable Settings/Utility Functions





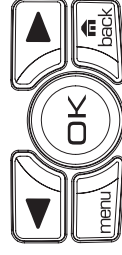

- All Tones/Alerts**  – Toggles all tones on or off.
- Backlight**  – Controls the backlight intensity.
- Horns/Lights**  – Toggles horns and lights feature on or off.
- Power Level**  – Toggles transmit power level between high and low.
- Squelch**  – Toggles squelch level between normal and tight.

■ **Accessing the Programmed Functions**

You can access various radio functions through one of the following ways:



OR

- Use the Menu Navigation Buttons as follows:
 - 1 To access the menu, press the  button. Press the appropriate **Menu Scroll** button ( or ) to access the menu functions.
 - 2 To select a function or enter a sub-menu, press the  button.
 - 3 To go back one menu level, or to return to the previous screen, press the  button. Long press the  button to return to the Home screen.

*The Menu Navigation Buttons are also available on a keypad microphone (see **Using the Keypad** on page 53).*

NOTE: Your radio automatically exits the menu after a period of inactivity and returns to your Home screen.

Identifying Radio Controls

■ Push-To-Talk (PTT) Button

The **PTT** button on the side of the microphone serves two basic purposes:

- While a call is in progress, the **PTT** button allows the radio to transmit to other radios in the call.

Press and hold down **PTT** button to talk. Release the **PTT** button to listen.

The microphone is activated when the **PTT** button is pressed.

- While a call is not in progress, the **PTT** button is used to make a new call (see **Making a Radio Call** on page 14).

If the **Talk Permit Tone** is enabled (see **Turning the Talk Permit Tone On or Off** on page 50), wait until the short alert tone ends before talking.

 During a call, if the **Channel Free Indication** feature is enabled on your radio (programmed by your dealer), you will hear a short alert tone the moment the target radio (the radio that is receiving your call) releases the **PTT** button, indicating the channel is free for you to respond.

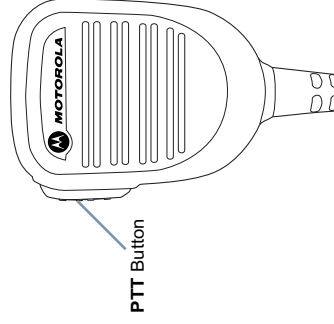

You will also hear the **Channel Free Indication** tone if your call is interrupted, for example when the radio receives an **Emergency Call**.

You can turn off the **Channel Free Indication** tone by disabling all radio tones and alerts (see **Turning Radio Tones/Alerts On or Off** on page 50).

■ Switching Between Analog and Digital Mode

Each channel in your radio can be configured as an analog channel or a digital channel. Use the **Channel Rocker** to switch between an analog or a digital channel.

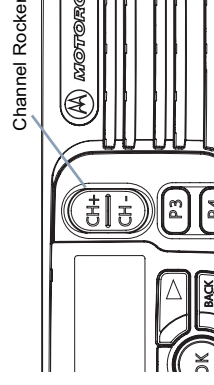

When switching from digital to analog mode, certain features are unavailable. Icons for the digital features (such as Messages) reflect this change by appearing "grayed out". Disabled features are hidden in the menu.

Your radio also has features available in both analog and digital mode. However, the minor differences in the way each feature works does **NOT** affect the performance of your radio.

NOTE: Your radio also switches between digital and analog modes during a dual mode scan (see **Scan** on page 23).

Identifying Status Indicators

Your radio indicates its operational status through the following:

Display Icons	page 7
Call Icons	page 8
Sent Item Icons	page 8
LED Indicators	page 9
Audio Tones	page 9

Display Icons

The liquid crystal display (LCD) of your radio shows the radio status, text entries, and menu entries.

The following are the icons that appear on the radio's display.



Received Signal Strength Indicator (RSSI)

The number of bars displayed represents the radio signal strength. Four bars indicates the strongest signal. This icon is only displayed while receiving.

Monitor

Selected channel is being monitored.

Power Level

Radio is set at Low power.

Radio is set at High power.



Tones Disable

Tones are turned off.



Option Board

The Option Board is enabled.



Option Board Non-Function

The Option Board is disabled.



GPS Available

The GPS feature is enabled. The icon stays lit when a position fix is available.



GPS Not Available/Out of Range

The GPS feature is enabled but is not receiving data from the satellite.

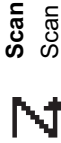

Scan

Scan feature is activated.



Priority Scan

Radio detects activity on channel/group designated as Priority 1 (if ● is blinking) or Priority 2 (if ● is steady).



Unread Message

User has unread message(s) in the Inbox.



Inbox Full

User's Inbox is full.

Identifying Status Indicators

Emergency

Radio is in Emergency mode.



Privacy

The Privacy feature is enabled.



Talkaround

In the absence of a repeater, radio is currently configured for direct radio to radio communication.



Call Icons

The following icons appear on the radio's display during a call. These icons also appear in the Contacts list to indicate alias or ID type.

Private Call

Indicates a Private Call in progress. In the Contacts list, it indicates a subscriber alias (name) or ID (number).



Group Call/All Call

Indicates a Group Call or All Call in progress. In the Contacts list, it indicates a group alias (name) or ID (number).



Sent Item Icons

The following icons appear at the top right corner of the radio's display in the Sent Items folder.



Sent Successfully

The text message is sent successfully.



Send Failed

The text message cannot be sent.



In-Progress

- The text message to a group alias or ID is pending transmission.
- The text message to a subscriber alias or ID is pending transmission, followed by waiting for acknowledgement.

LED Indicators

LED indicators show the operational status of your radio.

Blinking red – Radio is receiving an Emergency transmission or has failed the self-test upon powering up.

Solid yellow – Radio is monitoring a channel.

Blinking yellow – Radio is scanning for activity or receiving a Call Alert.

Solid green – Radio is transmitting.

Blinking green – Radio is powering up, receiving a non-privacy-enabled call or data, or detecting activity over the air.

Rapidly blinking green – Radio is receiving a privacy-enabled call or data.

NOTE: When the green LED blinks, it indicates the radio detects activity over the air. Due to the nature of the digital protocol, this activity may or may not affect the radio's programmed channel.

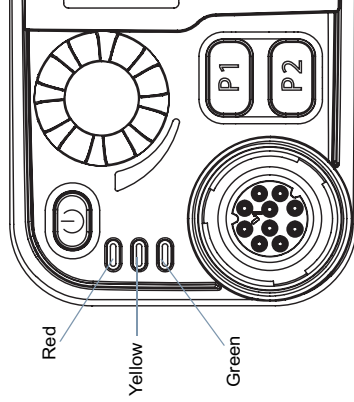

Upon a **PTT** button press, if the radio is programmed for polite operation, the radio automatically determines whether a transmission is permitted via a **Talk Permit** or a **Talk Denial** tone.

Audio Tones

Alert tones provide you with audible indications of the radio's status or the radio's response to data received.

Continuous Tone  A monotone sound. Sounds continuously until termination.

Periodic Tone  Sounds periodically depending on the duration set by the radio. Tone starts, stops, and repeats itself.

Repetitive Tone  A single tone that repeats itself until it is terminated by the user.

Momentary Tone  Sounds only once for a short period of time defined by the radio.

Identifying Status Indicators

Receiving and Making Calls

Once you understand how your MOTOTRBO Mobile is configured, you are ready to use your radio.

Use this navigation guide to familiarize yourself with the basic Call features:

Selecting a Zone	page 10
Selecting a Radio Channel, Subscriber Alias or ID, or Group Alias or ID	page 11
Receiving and Responding to a Radio Call	page 11
Making a Radio Call	page 14
Talkaround	page 17
Permanent Monitor	page 17







Selecting a Zone

A zone is a group of channels. Your radio supports up to a maximum of 50 zones.

Use the following procedure to select a zone.

Procedure:

Press the programmed **Zone** button and proceed to step 3. **OR** Follow the procedure below.

- 1 Press  to access the menu.
- 2 Press  or  to **Zone** and press  to select.
- 3 The current zone is displayed and indicated by a ✓.
- 4 Press  or  to the required zone and press  to select.
- 5 The display shows **<Zone> Selected** momentarily and returns to the selected zone screen.

■ Selecting a Radio Channel, Subscriber Alias or ID, or Group Alias or ID

Procedure:

Once the required zone is displayed (if you have multiple zones in your radio), press the Channel Rocker to select the channel, subscriber alias or ID, or group alias or ID.

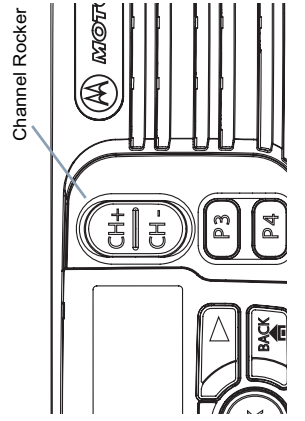

■ Receiving and Responding to a Radio Call

Once the channel, subscriber alias or ID, or group alias or ID is displayed, you can proceed to receive and respond to calls.

The green LED lights up while the radio is transmitting and blinks when the radio is receiving.

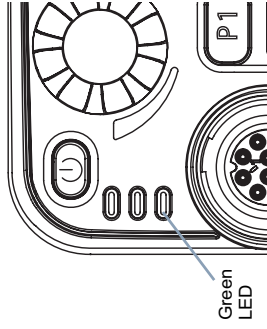

NOTE: The green LED lights up while the radio is transmitting and blinks rapidly when the radio is receiving a privacy-enabled call.

To unscramble a privacy-enabled call, your radio must have the same Privacy Key (programmed by your dealer) as the transmitting radio (the radio you are receiving the call from). See **Privacy** on page 44 for more information. 

 **Receiving and Responding to a Group Call**

To receive a call from a group of users, your radio must be configured as part of that group.

Procedure:

When you receive a Group Call (while on the Home screen):

- 1 The green LED blinks.
- 2 The first line of the display shows the caller alias or ID, and the RSSI icon. The second line displays the group alias or ID, and the Group Call icon (in Digital mode only).
 If the Channel Free Indication feature is enabled, you will hear a short alert tone the moment the transmitting radio releases the **PTT** button, indicating the channel is free for you to respond.
- 3 Press the **PTT** button to respond to the call. The green LED lights up.
- 4 Wait for the Talk Permit Tone to finish (if enabled) and speak clearly into the microphone.
- 5 Release the **PTT** button to listen.

- 6 If there is no voice activity for a predetermined period of time, the call ends.

See **Making a Group Call** on page 14 for details on making a Group Call.

NOTE: If the radio receives a Group Call while not on the Home screen, it remains on its current screen prior to answering the call.

Long press the  button to go to Home screen to view the caller alias before replying.

 **Receiving and Responding to a Private Call** 

A Private Call is a call from an individual radio to another individual radio.

There are two types of Private Calls. The first type, where a radio presence check is performed prior to setting up the call, while the other sets up the call immediately.

When your radio is checked, the green LED blinks.

Only one of these call types can be programmed to your radio by your dealer.

Procedure:

When you receive a Private Call:

- 1 The green LED blinks.
- 2 The first line of the display shows the subscriber alias or ID, and the RSSI icon. The second line displays **Private Call** and the Private Call icon.
If the Channel Free Indication feature is enabled, you will hear a short alert tone the moment the transmitting radio releases the **PTT** button, indicating the channel is free for you to respond.
- 3 Press the **PTT** button to respond to the call. The green LED lights up.
- 4 Wait for the Talk Permit Tone to finish (if enabled) and speak clearly into the microphone.
- 5 Release the **PTT** button to listen.
- 6 If there is no voice activity for a predetermined period of time, the call ends.
- 7 You hear a short tone. The display shows **Call Ended**.

See **Making a Private Call** on page 15 for details on making a Private Call.

 **Receiving an All Call**

An All Call is a call from an individual radio to every radio on the channel. It is used to make important announcements requiring the user's full attention.

Procedure:

When you receive an All Call:

- 1 A tone sounds and the green LED blinks.
- 2 The first line of the display shows the caller alias, and the RSSI icon. The second line displays **All Call** and the All Call icon.
- 3 Once the All Call ends, the radio returns to the previous screen before receiving the call.
 If the Channel Free Indication feature is enabled, you will hear a short alert tone the moment the transmitting radio releases the **PTT** button, indicating the channel is now available for use.

You cannot respond to an All Call.



See **Making an All Call** on page 16 for details on making an All Call.

NOTE: The radio stops receiving the All Call if you switch to a different channel while receiving the call.
During an All Call, you will **not** be able to continue with any menu navigation or editing until the call ends.

Receiving and Making Calls

■ Making a Radio Call

You can select a channel, subscriber alias or ID, or group alias or ID by using:

- The Channel Rocker
- A programmed **One Touch Call** button 
- The Contacts list (see **Contacts Settings** on page 25)
- Manual Dial (via Contacts) – This method is for Private Calls only and is dialed using a keypad microphone (see **Making a Private Call by Manual Dial** on page 56) 

NOTE: Your radio must have the Privacy feature enabled on the channel to send a privacy-enabled transmission. Only target radios with the same Privacy Key as your radio will be able to unscramble the transmission. See **Privacy** on page 44 for more information. 

📄 Making a Call with the Channel Rocker

📄 Making a Group Call

To make a call to a group of users, your radio must be configured as part of that group.

Procedure:

- 1 Press the Channel Rocker to select the channel with the active group alias or ID.
- 2 Press the **PTT** button to make the call. The green LED lights up. The display shows the group alias or ID, and the Group Call icon.
- 3 Wait for the Talk Permit Tone to finish (if enabled) and speak clearly into the microphone.
- 4 Release the **PTT** button to listen. When the target radio responds, the green LED blinks. You see the Group Call icon, the group alias or ID, and transmitting radio alias or ID on your display.

- 5 If the Channel Free Indication feature is enabled, you will hear a short alert tone the moment the target radio releases the **PTT** button, indicating the channel is free for you to respond. Press the **PTT** button to respond. 
OR
If there is no voice activity for a predetermined period of time, the call ends.
- 6 Radio returns to the previous screen you were on prior to receiving the call.

*You can also make a Group Call via Contacts (see **Making a Group Call from Contacts** on page 26).*

Making a Private Call

Procedure:

- 1 Press the Channel Rocker to select the channel with the active subscriber alias or ID.
- 2 Press the **PTT** button to make the call. The green LED lights up. The first line displays the subscriber alias or ID. The second line displays **Private Call** and the Private Call icon.

- 3 Wait for the Talk Permit Tone to finish (if enabled) and speak clearly into the microphone.
- 4 Release the **PTT** button to listen. When the target radio responds, the green LED blinks.
- 5 If the Channel Free Indication feature is enabled, you will hear a short alert tone the moment the target radio releases the **PTT** button, indicating the channel is free for you to respond. Press the **PTT** button to respond.
OR
If there is no voice activity for a predetermined period of time, the call ends.
- 6 You hear a short tone. The display shows **Call Ended**.

*You can also make a Private Call via Contacts (see **Making a Private Call from Contacts** on page 26), manually dial a Private Call (see **Making a Private Call by Manual Dial** on page 56) or perform a quick alphanumeric search for the required target alias via a keypad entry (see **Making a Private Call by Alias Search** on page 56).*

Receiving and Making Calls

 **Making an All Call**

This feature allows you to transmit to all users on the channel. Your radio must be programmed to allow you to use this feature.

Procedure:

- 1 Press the Channel Rocker to select the channel with the active All Call group alias or ID.
- 2 Press the **PTT** button to make the call. The green LED lights up. The display shows the All Call group alias or ID, and the All Call icon.
- 3 Wait for the Talk Permit Tone to finish (if enabled) and speak clearly into the microphone.

Users on the channel cannot respond to an All Call.

 **Making a Group or Private Call with the One Touch Call Button** 

The One Touch Call feature allows you to make a Group or Private Call to a predefined alias or ID easily. This feature can be assigned to a short or long programmable button press.

You can **ONLY** have one alias or ID assigned to a **One Touch Call** button. Your radio can have multiple **One Touch Call** buttons programmed.

Procedure:

- 1 Press the programmed **One Touch Call** button to make a Group or Private Call to the predefined alias or ID.
- 2 Press the **PTT** button to make the call. The green LED lights up. The display shows the group/subscriber alias or ID, and the Group/Private Call icon.
- 3 Wait for the Talk Permit Tone to finish (if enabled) and speak clearly into the microphone.
- 4 Release the **PTT** button to listen. When the target radio responds, the green LED blinks.
- 5 If the Channel Free Indication feature is enabled, you will hear a short alert tone the moment the target radio releases the **PTT** button, indicating the channel is free for you to respond. Press the **PTT** button to respond.
OR
If there is no voice activity for a predetermined period of time, the call ends.
- 6 Radio returns to the screen you were on prior to receiving the call.

For a Private Call, you hear a short tone when the call ends.

■ Talkaround











You can continue to communicate when your repeater is not operating, or when your radio is out of the repeater's range but within talking range of other radios. This is called "talkaround".

Procedure:

Press the programmed **Repeater/Talkaround** button to toggle between talkaround and repeater modes.

OR

Follow the procedure below.

- 1 Press  to access the menu.
- 2 Press  or  to Utilities and press  to select.
- 3 Press  or  to Radio Settings and press  to select.
- 4 Press  or  to Talkaround and press  to select.

5 You see **Turn On** if the radio is currently in Repeater mode.

OR

You see **Turn Off** if the radio is currently in Talkaround mode.

6 Press  to select.

7 The display shows **Talkaround On**.

OR

The display shows **Talkaround Off**.

8 The screen automatically returns to the previous menu.

The Talkaround setting is retained even after powering down.

■ Permanent Monitor

Use the Permanent Monitor feature to continuously monitor a selected channel for activity.

Procedure:

- 1 Press the programmed **Permanent Monitor** button.
- 2 Radio sounds an alert tone, the yellow LED lights up, and the display shows **Permanent Monitor On**. The monitor icon appears on the display.
- 3 Press the programmed **Permanent Monitor** button to exit Permanent Monitor mode.
- 4 Radio sounds an alert tone, the yellow LED turns off, and display shows **Permanent Monitor Off**.

Advanced Features

Use this navigation guide to learn more about advanced features available with your radio:

Radio Check	page 18
Remote Monitor	page 19
Scan Lists	page 21
Scan	page 23
Contacts Settings	page 25
Call Indicator Settings	page 27
Call Log Features	page 29
Call Alert Operation	page 31
Emergency Operation	page 32
Text Messaging Features	page 37
Privacy	page 44
Security	page 45
Utilities	page 47

Radio Check



If enabled, this feature allows you to determine if another radio is active in a system without disturbing the user of that radio. No audible or visual notification is shown on the target radio.

This feature is only applicable for subscriber aliases or IDs.

Sending a Radio Check

Procedure:

Using the programmed **Radio Check** button.

- 1 Press the programmed **Radio Check** button.
- 2  or  to the required subscriber alias or ID and press  to select.
- 3 The display shows **Radio Check: <Subscriber Alias or ID>**, indicating that Radio Check is in progress. The green LED lights up.
- 4 Wait for acknowledgement.
- 5 If the target radio is active in the system, a tone sounds and the display briefly shows **Target Radio Available**.
OR
If the target radio is not active in the system, a tone sounds and the display briefly shows **Target Radio Not Available**.
- 6 Radio returns to the subscriber alias or ID screen.

OR

Procedure:

Using the menu.

- 1  to access the menu.

- 2 or to **Contacts** and press to select.
- 3 or to the required subscriber alias or ID and press to select.
- 4 or to **Radio Check** and press to select.
- 5 The display shows **Radio Check: <Subscriber Alias or ID>**, indicating that Radio Check is in progress. The green LED lights up.
- 6 Wait for acknowledgement.
- 7 If the target radio is active in the system, a tone sounds and the display briefly shows **Target Radio Available**.
OR
If the target radio is not active in the system, a tone sounds and the display briefly shows **Target Radio Not Available**.
- 8 Radio returns to the subscriber alias or ID screen.

If the button is pressed when the radio is waiting for acknowledgement, a tone sounds, and the radio terminates all retries and exits Radio Check mode.

You can also initiate Radio Check via manual dial (see **Initiating a Radio Check by Manual Dial** on page 54).

■ Remote Monitor

Use the Remote Monitor feature to turn on the microphone of a target radio (subscriber IDs only). No audible or visual indication is given to the target radio. You can use this feature to monitor, remotely, any audible activity surrounding the target radio. Your radio must be programmed to allow you to use this feature.

Initiating Remote Monitor

Procedure:

Using the programmed **Remote Monitor** button.











- 1 Press the programmed **Remote Monitor** button.
- 2 or to the required subscriber alias or ID and press to select.
- 3 Radio sounds an alert tone and the green LED blinks.
- 4 Wait for acknowledgement.
- 5 The display shows **Remote Monitor Successful**.
OR
The display shows **Remote Monitor Failed**.

- 6** If successful:
The radio starts receiving audio from the monitored radio for a programmed duration.
Once the timer expires, the radio sounds an alert tone and the green LED turns off. The display shows Remote Monitor Ended.
OR
If unsuccessful:
The radio repeats the attempt until the programmed number of tries expires.

OR

Procedure:

Using the menu.

- 1  to access the menu.
- 2  or  to Contacts and press  to select.
- 3  or  to the required subscriber alias or ID and press  to select.
- 4  or  to Remote Mon., and press  to select.

- 5 Radio sounds an alert tone and the green LED blinks.
- 6 Wait for acknowledgment.
- 7 The display shows Remote Monitor Successful.
OR
The display shows Remote Monitor Failed.
- 8 If successful:
The radio starts receiving audio from the monitored radio for a programmed duration.
Once the timer expires, the radio sounds an alert tone and the green LED turns off. The display shows Remote Monitor Ended.
OR
If unsuccessful:
The radio repeats the attempt until the programmed number of tries expires.

*You can also manually select a target radio address (see **Initiating Remote Monitor by Manual Dial** on page 55).*

■ Scan Lists









Scan lists are created and assigned to individual channels/groups. Your radio scans for voice activity by cycling through the channel/group sequence specified in the scan list for the current channel/group.

Your radio can support up to 32 scan lists, with a maximum of 16 members in a list. Each scan list supports a mixture of both analog and digital entries.

You can add, delete, or prioritize channels by editing a scan list.

📄 Viewing an Entry in the Scan List

Procedure:

- 1  to access the menu.
- 2  or  to Scan and press  to select.
- 3  or  to View/Edit List and press  to select.
- 4 Use  or  to view each member on the list.























*The priority icon appears left of the member's alias, if set, to indicate whether the member is on a Priority 1 or Priority 2 channel list. You **cannot** have multiple Priority 1 or Priority 2 channels in a scan list.*

*There is no priority icon if priority is set to **None**.*

📄 Editing the Scan List

📄 Adding a New Entry to the Scan List



















Procedure:

- 1  to access the menu.
- 2  or  to Scan and press  to select.
- 3  or  to View/Edit List and press  to select.
- 4  or  to Add Member and press  to select.
- 5  or  to the required alias or ID and press  to select.
- 6  or  to the required priority level and press  to select.
- 7 The display shows *Entry Saved, followed immediately by Add Another?*
- 8  or  to Yes and press  to select, to add another entry, and repeat steps 5 and 6.
OR
 or  to No and press  to select to save the current list.

Advanced Features

Deleting an Entry from the Scan List

















Procedure:

- 1  to access the menu.
- 2  or  to Scan and press  to select.
- 3  or  to View/Edit List and press  to select.
- 4  or  to the required alias or ID and press  to select.
- 5  or  to Delete and press  to select.
- 6 At Delete Entry?,  or  to Yes and press  to select, to delete the entry. The display shows Entry Deleted.
OR
 or  to No and press  to select to return to the previous screen.
- 7 Repeat steps 4 to 6 to delete other entries.

After deleting all required aliases or IDs, long press  to return to the Home screen.

Setting and Editing Priority for an Entry in the Scan List

Procedure:

- 1  to access the menu.
- 2  or  to Scan and press  to select.
- 3  or  to View/Edit List and press  to select.
- 4  or  to the required alias or ID and press  to select.
- 5  or  to Edit Priority and press  to select.
- 6  or  to the required priority level and press  to select.
- 7 The display shows Entry Saved before returning to the previous screen.
- 8 The priority icon appears left of the member's name.

There is no priority icon if priority is set to **None**.

■ Scan

When you start a scan, your radio cycles through the programmed scan list for the current channel looking for voice activity.

The yellow LED blinks and you see the scan icon on the display. During a dual mode scan, if you are on a digital channel, and your radio locks onto an analog channel, it automatically switches from digital mode to analog mode for the duration of the call. This is also true for the reverse.





There are two ways of initiating scan:

- **Main Channel Scan (Manual):** Your radio scans all the channels/groups in your scan list. On entering scan, your radio may – depending on the settings – automatically start on the last scanned “active” channel/group or on the channel where scan was initiated.
- **Auto Scan (Automatic):** Your radio automatically starts scanning when you select a channel/group that has Auto Scan enabled.

📄 Starting and Stopping Scan

Procedure:

Press the programmed **Scan** button to start or stop Scan. **OR** Follow the procedure below.

- 1 Use the Channel Rocker to select a channel programmed with a scan list.
- 2  to access the menu.
- 3  or  to **Scan** and press  to select.
- 4 The display shows **Turn On** if scan is disabled. **OR** The display shows **Turn Off** if scan is enabled.
- 5 Press  to select.
- 6 The yellow LED blinks and the scan icon is displayed when Scan is enabled. **OR** The LED turns off and the scan icon is not displayed when Scan is disabled.

While scanning, the radio will only accept data (e.g. text message, location, telemetry, or PC data) if received on its Selected Channel.



Responding to a Transmission During a Scan

During scanning, your radio stops on a channel/group where activity is detected. The radio stays on that channel for a programmed time period known as “hang time”.

Procedure:

- 1 If the Channel Free Indication feature is enabled, you will hear a short alert tone the moment the transmitting radio releases the **PTT** button, indicating the channel is free for you to respond.  Press the **PTT** button during hang time. The green LED lights up.
- 2 Wait for the Talk Permit Tone to finish (if enabled) and speak clearly into the microphone.
- 3 Release the **PTT** button to listen.
- 4 If you do not respond within the hang time, the radio returns to scanning other channels/groups.



Deleting a Nuisance Channel

If a channel continually generates unwanted calls or noise (termed a “nuisance” channel), you can temporarily remove the unwanted channel from the scan list.

This capability does not apply to the channel designated as the Selected Channel.

Procedure:

- 1 When your radio “locks on to” an unwanted or nuisance channel, press the programmed **Nuisance Channel Delete** button until you hear a tone.
- 2 Release the **Nuisance Channel Delete** button. The nuisance channel is deleted.

*Deleting a “nuisance” channel is **only possible through the programmed Nuisance Channel Delete button. This feature is not accessible through the menu.***

Restoring a Nuisance Channel

Procedure:

To restore the deleted nuisance channel, do **one** of the following:

- Power the radio off and then powering it on again, **OR**
- Stop and restart a scan via the programmed **Scan** button or menu, **OR**
- Change the channel via the Channel Rocker.

■ Contacts Settings

Contacts provides “address-book” capabilities on your radio. Each entry corresponds to an alias or ID that you use to initiate a call.

Additionally, each entry, depending on context, associates with **one** of five types of calls: Group Call, Private Call, All Call, PC Call or Dispatch Call.

PC Call and Dispatch Call are data-related. They are only available with the applications. Refer to the data applications documentation for further details.

NOTE: If the Privacy feature is enabled on a channel, you can make privacy-enabled Group Call, Private Call, and All Call on that channel. Only target radios with the same Privacy Key as your radio will be able to unscramble the transmission. See **Privacy** on page 44 for more information. 

Your radio supports two Contacts lists, one for Analog contacts (with a maximum of 128 members) and one for Digital contacts (with a maximum of 256 members).

Each entry within Contacts displays the following information:

- Call Type
- Call Alias
- Call ID







Advanced Features

NOTE: You can add, delete, or edit subscriber aliases or IDs for the Digital Contacts list.

For the Analog Contacts list, you can only view the list and initiate a Call Alert. Adding, deleting, and editing capabilities can only be performed by your dealer.

Making a Group Call from Contacts







Procedure:

- 1  to access the menu.
- 2  or  to **C**ontacts and press  to select. The entries are alphabetically sorted.
- 3  or  to the required group alias or ID.
- 4 Press the **PTT** button to make the call. The green LED lights up. The display shows the group alias or ID, and the Group Call icon.
- 5 Wait for the Talk Permit Tone to finish (if enabled) and speak clearly into the microphone.
- 6 Release the **PTT** button to listen. When any user in the group responds, the green LED blinks. You see the Group Call icon, the group alias or ID, and that user's alias or ID on your display.

- 7 If the Channel Free Indication feature is enabled, you will hear a short alert tone the moment the target radio releases the **PTT** button, indicating the channel is free for you to respond. Press the **PTT** button to respond.  **OR**
If there is no voice activity for a programmed period of time, the call ends.

Making a Private Call from Contacts

Procedure:

- 1  to access the menu.
- 2  or  to **C**ontacts and press  to select. The entries are alphabetically sorted.
- 3  or  to the required subscriber alias or ID.
- 4 Press the **PTT** button to make the call. The green LED lights up. The first line displays the subscriber alias or ID. The second line displays **P**ri~~v~~ate **C**all and the Private Call icon.
- 5 Wait for the Talk Permit Tone to finish (if enabled) and speak clearly into the microphone.

- 6 Release the **PTT** button to listen. When the target radio responds, the green LED blinks and the display shows the transmitting user's alias or ID.
- 7 If the Channel Free Indication feature is enabled, you will hear a short alert tone the moment the target radio releases the **PTT** button, indicating the channel is free for you to respond. Press the **PTT** button to respond.
- OR**
If there is no voice activity for a programmed period of time, the call ends.
- 8 You hear a short tone. The display shows **Call Ended**.

NOTE: If you release the **PTT** button while the radio is setting up the call, it exits without any indication and returns to the previous screen.

Your radio may be programmed to perform a radio presence check prior to setting up the Private Call. If the target radio is not available, you hear a short tone and see **Party Not Available** on the display.

The radio returns to the menu prior to initiating the radio presence check.

Call Indicator Settings

Activating and Deactivating Call Ringers for Private Calls

You can turn on or off the ringing tones for a received Private Call.























Procedure:

- 1 Press **Menu** to access the menu.
- 2 Press **Left Arrow** or **Right Arrow** to **Utilities** and press **OK** to select.
- 3 Press **Left Arrow** or **Right Arrow** to **Radio Settings** and press **OK** to select.
- 4 Press **Left Arrow** or **Right Arrow** to **Tones/Alerts** and press **OK** to select.
- 5 Press **Left Arrow** or **Right Arrow** to **Call Ringers** and press **OK** to select.
- 6 Press **Left Arrow** or **Right Arrow** to **Private Call** and press **OK** to select.
- 7 The display shows **Turn On**. Press **OK** to enable Call Ringers for Private Calls. The display shows **Private Call Ringer On**.
OR
The display shows **Turn Off**. Press **OK** to disable Call Ringers for Private Calls. The display shows **Private Call Ringer Off**.

Activating and Deactivating Call Ringers for Text Messaging

You can turn on or off the ringing tones for a received Text Message.













Procedure:

- 1  to access the menu.
- 2  or  to Utilities and press  to select.
- 3  or  to Radio Settings and press  to select.
- 4  or  to Tones/Alerts and press  to select.
- 5  or  to Call Ringers and press  to select.
- 6  or  to Text Message and press  to select.
- 7 The current tone is indicated by a ✓.
- 8  or  to the preferred tone and press  to select. The display shows Tone <Number> Selected and a ✓ appears left of the selected tone.
OR
 or  to Turn Off and press  to select. The display shows Text Message Ringer Off and a ✓ appears left of Turn Off.

Assigning Ring Styles

You can program your radio to sound one of ten predefined ringing tones when receiving a Call Alert or a Text Message from a particular contact.

Procedure:















- 1  to access the menu.
- 2  or  to Contacts and press  to select. The entries are alphabetically sorted.
- 3  or  to the required alias or ID and press  to select.
- 4  or  to Ring Style and press  to select.
- 5 A ✓ indicates the current selected tone.
- 6  or  to the required tone and press  to select.
- 7 The display shows Contact Saved.

The radio sounds out each ring style as you navigate through the list.

Escalating Alarm Tone Volume

You can program your radio to continually alert you when a radio call remains unanswered. This is done by automatically increasing the alarm tone volume over time. This feature is known as Escalater.

Procedure:

- 1  to access the menu.
- 2  or  to Utilities and press  to select.
- 3  or  to Radio Settings and press  to select.
- 4  or  to Tones/Alerts and press  to select.
- 5  or  to Escalater and press  to select.
- 6 The display shows Turn On. Press  to enable Escalater.
The display shows Escalater On.
OR
The display shows Turn Off. Press  to disable Escalater.
The display shows Escalater Off.

Call Log Features

Your radio keeps track of all recent outgoing, answered, and missed Private Calls. Use the call log feature to view and manage recent calls.









You can perform the following tasks in each of your call lists:

- Store alias or ID to Contacts
- Delete

Viewing Recent Calls

The lists are Missed, Answered, and Outgoing.

Procedure:

- 1  to access the menu.
- 2  or  to Call Log and press  to select.
- 3  or  to preferred list and press  to select.
- 4 The display shows the most recent entry at the top of the list.
- 5  or  to view the list.

Press the **PTT** button to start a *Private Call with the current selected alias or ID.*

Missed Call Screen

Whenever a call is missed, your radio displays a missed call message. Select **View** to view it immediately or **View Later** to view at a later time.

NOTE: The radio exits the Missed Call screen and sets up a Private Call if you press the **PTT** button while viewing a missed call number.

Procedure:

- 1 The display shows **Missed Calls**, along with the number of calls missed and **View**.
- 2 Press **OK** to view the missed call alias or ID. The missed call log list appears on display.
Press **OK** to store or delete the entry.
OR
◀ or **▶** to **View Later** and press **OK** to select. You return to the Home screen.

To store/save an alias or ID from the Missed Call list, see **Storing an Alias or ID from the Missed Call List** on page 57.

Deleting a Call from a Call List

Procedure:

- 1 **Menu** to access the menu.
- 2 **◀** or **▶** to **Call Log** and press **OK** to select.
- 3 **◀** or **▶** to the required list and press **OK** to select.
- 4 **◀** or **▶** to the required alias or ID and press **OK** to select.
- 5 **◀** or **▶** to **Delete Entry** and press **OK** to select.
- 6 **◀** or **▶** to **Yes** and press **OK** to select.
- 7 The display shows **Entry Deleted**.

When you select a call list and it contains no entries, the display shows *List Empty*, and sounds a low tone if Keypad Tones are turned on (see **Turning Keypad Tones On or Off** on page 54).

■ Call Alert Operation

Call Alert paging enables you to alert a specific radio user to call you back when they are able to do so.

This feature is applicable for subscriber aliases or IDs only and is accessible through the menu via Contacts or manual dial.

Receiving and Acknowledging a Call Alert

When you receive a Call Alert page, you see `Call Alert` that alternates with the alias or ID of the calling radio on the display.

Procedure:

- 1 You hear a repetitive tone. The yellow LED blinks.
- 2 Press and release the **PTT** button to acknowledge the alert.
OR
Press **OK** to exit the Call Alert.

Making a Call Alert from the Contacts List

Procedure:

- 1 Press **Menu** to access the menu.
- 2 Press **Left Arrow** or **Right Arrow** to `Contacts` and press **OK** to select.
- 3 Press **Left Arrow** or **Right Arrow** to the required subscriber alias or ID and press **OK** to select.
- 4 Press **Left Arrow** or **Right Arrow** to `Call Alert` and press **OK** to select.
- 5 The display shows `Call Alert: <Subscriber Alias or ID>`, indicating that the Call Alert has been sent.
- 6 The green LED lights up when your radio is sending the Call Alert.
- 7 If the Call Alert acknowledgement is received, a tone sounds and the display shows `Call Alert Successful`.
OR
If the Call Alert acknowledgement is not received, a tone sounds and the display shows `Call Alert Failed`.

You can also send a Call Alert by manually dialing the subscriber ID (see **Making a Call Alert by Manual Dial** on page 58).

Making a Call Alert with the One Touch Call Button

Procedure:

- 1 Press the programmed **One Touch Call** button to make a Call Alert to the predefined alias or ID.
- 2 The display shows `Call Alert: <Subscriber Alias or ID>`, indicating that the Call Alert has been sent.
- 3 The green LED lights up when your radio is sending the Call Alert.
- 4 If the Call Alert acknowledgement is received, a tone sounds and the display shows `Call Alert Successful`.

OR

If the Call Alert acknowledgement is not received, a tone sounds and the display shows `Call Alert Failed`.

Emergency Operation

An Emergency Alarm is used to indicate a critical situation. You are able to initiate an Emergency at any time on any screen display even when there is activity on the current channel.

Your radio supports 3 Emergency Alarms:

- Emergency Alarm
- Emergency Alarm with Call
- Emergency Alarm with Voice to Follow 

In addition, each alarm has the following types:

- Regular – Radio transmits an alarm signal and shows audio and/or visual indicators.
- Silent – Radio transmits an alarm signal without any audio or visual indicators. There will be no response (call) from the target radio until you press the **PTT** button to initiate the call.
- Silent with Voice – Radio transmits an alarm signal and is able to receive an incoming call, without any audio or visual indicators, until you press the **PTT** button to initiate, or respond to, the call.

Only **one** of the Emergency Alarms above can be assigned to the programmed **Emergency** button or the **Emergency** footswitch.

Receiving an Emergency Alarm

Procedure:

- 1 When receiving an Emergency Alarm, the display shows the Emergency icon, the number of alarms received, and **Emergency Received**, which alternates with the alias or ID of the sender.
- 2 A tone sounds and the red LED blinks.
- 3 If enabled, your radio automatically acknowledges the Emergency Alarm.

When your radio receives an Emergency Alarm, it displays the Emergency Alarm received indications until acknowledgement is sent and you exit the Emergency mode.



You will not be able to receive any other indications or displays for any other calls until you exit the Emergency Alarm received screen.

NOTE: Short press , then long press the programmed **Emergency** button to clear the Emergency Alarm received indications and exit Emergency mode.

Responding to an Emergency Alarm

Procedure:

When receiving an Emergency Alarm:

- 1 Press any button to stop all Emergency Alarm received indications.
- 2 If the Channel Free Indication feature is enabled, you will hear a short alert tone the moment the transmitting radio releases the **PTT** button, indicating the channel is free for you to respond. 
Press **PTT** button to initiate a call with the emergency initiating radio. The green LED lights up. Your radio remains in the Emergency mode.
- 3 Wait for the Talk Permit Tone to finish (if enabled) and speak clearly into the microphone.
- 4 Release the **PTT** button to listen. When the emergency initiating radio responds, the green LED blinks. You see the Group Call icon, the group alias or ID, and transmitting radio alias or ID on your display.
- 5 Once your call ends, short press , then long press the programmed **Emergency** button to clear the Emergency Call received indications and exit Emergency mode.
- 6 The radio returns to the Home screen.

Sending an Emergency Alarm

This feature allows you to send an Emergency Alarm, a non-voice signal, which triggers an alert indication on another radio.

Procedure:

- 1 Press the programmed **Emergency** button or the **Emergency** footswitch.
- 2 The display shows **Sending Alarm**, which alternates with your radio ID. The green LED lights up and the Emergency icon appears on the Home screen display.
- 3 When an Emergency Alarm acknowledgment is received, the Emergency tone sounds and the green LED blinks. The display shows **Emergency Alarm Successful**.
OR
If your radio does not receive an Emergency Alarm acknowledgement, and after all retries have been exhausted, a tone sounds and the display shows **Emergency Alarm Failed**.
- 4 Radio exits the Emergency Alarm mode and returns to the Home screen.

If your radio is set to Silent, it will not display any audio or visual indicators during Emergency mode.

Sending an Emergency Alarm with Call

This feature allows you send an Emergency Alarm to another radio. Upon acknowledgement, both radios can communicate over a programmed Emergency channel.

Procedure:

- 1 Press the programmed **Emergency** button or the **Emergency** footswitch.
- 2 The display shows **Sending Alarm**, which alternates with your radio ID. The green LED lights up and the Emergency icon appears on the Home screen display.
- 3 When an Emergency Alarm acknowledgment is received, the Emergency tone sounds and the green LED blinks. The display shows **Emergency Alarm Successful**.
- 4 Press **PTT** button to make the call. The green LED lights up and the group icon appears on the display.
- 5 Wait for the Talk Permit Tone to finish (if enabled) and speak clearly into the microphone.
- 6 Release the **PTT** button to listen.

- 7 If the Channel Free Indication feature is enabled, you will hear a short alert tone the moment the target radio releases the **PTT** button, indicating the channel is free for you to respond. 
- OR**
- Long press the programmed **Emergency** button to exit the Emergency mode.

- 8 The radio returns to the Home screen.

*If your radio is set to Silent, it will not display any audio or visual indicators during Emergency mode, or receive any response (call) from the target radio, until you press the **PTT** button to initiate the call.*

*If your radio is set to Silent with Voice, it will not display any audio or visual indicators during Emergency mode, or when you are receiving a call from the target radio. The indicators will only appear once you press the **PTT** button to initiate, or respond to, the call.*

Sending an Emergency Alarm with Voice to Follow

This feature allows you to send an Emergency Alarm to another radio. Upon acknowledgement, your radio's microphone is automatically activated, allowing you to communicate with the other radio without pressing the **PTT** button.

This activated microphone state is also known as "hot mic".

If you press the **PTT** button during the programmed hot mic transmission period, the radio ignores the **PTT** press and remains in Emergency mode.

NOTE: If you press the **PTT** button during hot mic, and continue to press it after the hot mic duration expires, the radio continues to transmit until you release the **PTT** button.

Procedure:

- 1 Press the programmed **Emergency** button or the **Emergency** footswitch.
- 2 The display shows **Sending Alarm**. The green LED lights up and the Emergency icon is displayed.

Advanced Features

- 3 Once the display shows **Emergency Alarm Successful**, speak clearly into the microphone. When hot mic has been enabled, the radio automatically transmits without a **PTT** press until the hot mic duration expires.
- 4 While transmitting, the green LED lights up and the Emergency icon appears on the display.
- 5 Once the hot mic duration expires, the radio automatically stops transmitting. To transmit again, press the **PTT** button.

*If your radio is set to Silent, it will not display any audio or visual indicators during Emergency mode, or receive any response from the target radio, until the programmed hot mic transmission period is over, and you press the **PTT** button.*

*If your radio is set to Silent with Voice, it will not display any audio or visual indicators during Emergency mode when you are making the call with hot mic, or when the target radio responds after the programmed hot mic transmission period is over. The indicators will only appear when you press the **PTT** button.*

NOTE: If the Emergency Alarm request fails, the radio returns to the Home screen.

Reinitiating an Emergency Mode

There are two instances where this can happen:

- You change the channel while the radio is in Emergency mode. This exits the Emergency mode. If Emergency Alarm is enabled on this new channel, the radio reinitiates Emergency.
- You press the programmed **Emergency** button during an Emergency initiation/transmission state. This causes the radio to exit this state, and to reinitiate Emergency.

Exiting Emergency Mode

Your radio exits Emergency mode when **one** of the following occurs:

- Emergency Alarm acknowledgement is received (for **Emergency Alarm only**), **OR**
- All retries to send the alarm have been exhausted, **OR**
- The programmed **Emergency** button is long pressed.

NOTE: If your radio is powered off, it exits the Emergency mode. The radio will not reinitiate the Emergency mode automatically when it is turned on again.

■ Text Messaging Features

Sending a Quick Text Message

Your radio supports a maximum of ten (10) Quick Text messages as programmed by your dealer.













NOTE: While Quick Text messages are programmed, you can edit each message before sending it. Only available with a keypad microphone (see *Editing a Quick Text Message* on page 60).

Procedure:

Press the programmed **Text Messaging** button and proceed to step 3.

OR

Follow the procedure below.

- 1  to access the menu.
- 2  or  to **Messages** and press  to select.
- 3  or  to **Quick Text** and press  to select.
- 4  or  to the required Quick Text and press  to select.
- 5  or  to the required alias or ID and press  to select.
- 6 The display shows **Text Message: <Subscriber/Group Alias or ID>**, confirming your message is being sent.

Advanced Features

7 If the message is sent successfully, a tone sounds and the display shows **Message Sent**.

OR

If the message cannot be sent, the display shows **Message Send Failed**.

*If the message fails to send, the radio returns you to the **Resend** option screen (see **Managing Fail-to-Send Text Messages** on page 38).*

Sending a Quick Text Message with the One Touch Call Button

1 Press the programmed **One Touch Call** button to send a predefined Quick Text message to a predefined alias or ID.

2 The display shows **Text Message: <Subscriber/Group Alias or ID>**, confirming your message is being sent.

3 If the message is sent successfully, a tone sounds and the display shows **Message Sent**.

OR

If the message cannot be sent, the display shows **Message Send Failed**.

*If the message fails to send, the radio returns you to the **Resend** option screen (see **Managing Fail-to-Send Text Messages** on page 38).*

Managing Fail-to-Send Text Messages

You can select one of the following options while at the **Resend** option screen:

- Resend
- Forward
- Edit (Only available with a keypad microphone – see *Editing a Text Message* on page 61 for more information)

Resending a Text Message





Procedure:

- 1 Press **OK** to resend the same message to the same subscriber/group alias or ID.
 - 2 If the message is sent successfully, a tone sounds and the display shows **Message Sent**.
- OR**
- If the message cannot be sent, the display shows **Message Send Failed**.

Forwarding a Text Message

Select **Forward** to send the message to another subscriber/group alias or ID.

Procedure:

- 1  or  to **Forward** and press **OK** to select.
 - 2  or  to the required alias or ID and press **OK** to select.
 - 3 The display shows **Text Message: <Subscriber/Group Alias or ID>**, confirming your message is being sent.
 - 4 If the message is sent, a tone sounds and the display shows **Message Sent**.
- OR**
- If the message is not sent, a low tone sounds and the display shows **Message Send Failed**.

You can also manually select a target radio address (see **Forwarding a Text Message by Manual Dial** on page 61).

Managing Sent Text Messages

Once a message is sent to another radio, it is saved in Sent Items. The most recent sent text message is always added to the top of the Sent Items list.

The Sent Items folder is capable of storing a maximum of thirty (30) last sent messages. When the folder is full, the next sent text message automatically replaces the oldest text message in the folder.

NOTE: Press  at any time to return to the previous screen or long press  to return to the Home screen.











Viewing a Sent Text Message

Procedure:

Press the programmed **Text Message** button and proceed to step 3.

OR

Follow the procedure below.

- 1  to access the menu.
- 2  or  to Messages and press  to select.
- 3  or  to Sent Items and press  to select.
- 4  or  to the required message and press  to select.





The icon at the top right corner of the screen indicates the status of the message (see **Sent Item Icons** on page 8).

Sending a Sent Text Message



You can select one of the following options while viewing a sent text message:

- Resend
- Forward
- Edit
- Delete

Procedure:

- 1 Press  again while viewing the message.
- 2  or  to Resend and press  to select.
- 3 The display shows Sending to: <Subscriber/Group Alias or ID>, confirming that the same message is being sent to the same target radio.
- 4 If the message is sent, a tone sounds and the display shows Message Sent.
OR
If the message is not sent, a low tone sounds and the display shows Message Send Failed.

If the message fails to send, the radio returns you to the Resend option screen. Press  to resend the message to the same subscriber/group alias or ID.

NOTE: Changing the volume, and pressing any button, except for , , or , returns you to the message.

The radio exits the **Resend** option screen if you press the **PTT** button to initiate a Private or Group Call, or to respond to a Group Call. It also exits the screen when the radio receives a text or telemetry message, an emergency call or alarm, or a call alert.

The display returns to the **Resend** option screen if you press the **PTT** button to respond to a Private Call (except if the radio is displaying the Missed Call screen), and at the end of an All Call.

Press  or  to access the *Forward*, *Edit*, or *Delete* option screen:

- Select *Forward* to send the selected text message to another target radio (see **Forwarding a Text Message** on page 38). You can also manually select a target radio address using a keypad microphone (see **Forwarding a Text Message by Manual Dial** on page 61).
- Select *Edit* to edit the selected text message before sending it (see **Editing a Text Message** on page 61). Only available with a keypad microphone.
- Select *Delete* to delete the text message.

NOTE: If you exit the message sending screen while the message is being sent, the radio updates the status of the message in the Sent Items folder without providing any indication in the display or via sound.

If the radio changes mode or powers down before the status of the message in Sent Items is updated, the radio cannot complete any In-Progress messages and automatically marks it with a Send Failed icon.

The radio supports a maximum of five (5) In-Progress messages at one time. During this period, the radio cannot send any new message and automatically marks it with a Send Failed icon.







Deleting All Sent Text Messages from Sent Items

Procedure:

Press the programmed **Text Message** button and proceed to step 3.

OR

Follow the procedure below.

- 1  to access the menu.
- 2  or  to Messages and press  to select.
- 3  or  to Sent Items and press  to select.

4 or to Delete All and press to select.

5 At Delete Message?, press to select Yes. The display shows Sent Items Cleared.

OR

At Delete Message?, or to No and press to return to the previous screen.

*When you select Sent Items and it contains no text messages, the display shows List Empty, and sounds a low tone if Keypad Tones are turned on (see **Turning Keypad Tones On or Off** on page 54).*

Receiving a Text Message

When receiving a message, the display shows the alias or ID of the sender and the message icon at the far left of the screen.

You can select one of the following options when receiving a text message:

- Read
- Read Later
- Delete

NOTE: The radio exits the Text Message alert screen and sets up a Private or Group Call if the **PTT** button is pressed when the radio is displaying the alert screen.

Reading a Text Message

Procedure:

1 or to Read and press to select.

2 Selected message in the Inbox opens.

3 Press to return to the Inbox.

OR

Press to reply, forward, or delete the text message.

Press or to access the *Read Later* or *Delete* option screen:

- Select *Read Later* to return to the screen you were on prior to receiving the text message.
- Select *Delete* to delete the text message.



Managing Received Text Messages

Use the Inbox to manage your text messages. The Inbox is capable of storing a maximum of 30 messages.

Your radio supports the following options for text messages:













- Reply (via Quick Text)
- Forward
- Delete
- Delete All

Text messages in the Inbox are sorted according to the most recently received.

NOTE: Press  at any time to return to the previous screen or long press  to return to the Home screen.

Viewing a Text Message from the Inbox

Procedure:

- 1  to access the menu.
 - 2  or  to Messages and press  to select.
 - 3  or  to Inbox and press  to select.
 - 4  or  to view the messages.
 - 5 Press  to select the current message, and press  again to reply, forward, or delete that message.
- OR**
- Long press  to return to the Home screen.

Unread messages are indicated with an exclamation mark (!).

















Replying to a Text Message with Quick Text



Procedure:

Press the programmed **Text Messaging** button and proceed to step 3.

OR

Follow the procedure below.

- 1  to access the menu.
- 2  or  to Messages and press  to select.
- 3  or  to Inbox and press  to select.
- 4  or  to the required message and press  to select.
- 5 Press  once more to access the sub-menu.
- 6  or  to Reply and press  to select.
- 7  or  to Quick Text and press  to select.

- 8  or  to the required message and press  to select.
- 9 The display shows Text Message: <Subscriber/Group Alias or ID>, confirming your message is being sent.
- 10 If the message is sent successfully, a tone sounds and the display shows Message Sent.
OR
If the message cannot be sent, the display shows Message Send Failed.

If the message fails to send, the radio returns you to the *Resend* option screen (see **Managing Fail-to-Send Text Messages** on page 38).

NOTE: If you are using a keypad microphone, you can also write and send a new message (see **Writing and Sending a Text Message** on page 58) or modify a Quick Text message before sending it (see **Editing a Quick Text Message** on page 60).

















Deleting a Text Message from the Inbox

Procedure:

Press the programmed **Text Messaging** button and proceed to step 3.

OR

Follow the procedure below.

- 1  to access the menu.
- 2  or  to Messages and press  to select.
- 3  or  to Inbox and press  to select.
- 4  or  to the required message and press  to select.
- 5 Press  once more to access the sub-menu.
- 6  or  to Delete and press  to select.
- 7 At Delete Message?,  or  to Yes and press  to select.
- 8 The display shows Message Deleted.
- 9 The screen returns to the Inbox.













Deleting All Text Messages from the Inbox

Procedure:

Press the programmed **Text Messaging** button and proceed to step 3.

OR

Follow the procedure below.

- 1  to access the menu.
- 2  or  to **Messages** and press  to select.
- 3  or  to **Inbox** and press  to select.
- 4  or  to **Delete All** and press  to select.
- 5 At **Delete Message?**,  or  to **Yes** and press  to select.
- 6 The display shows **Inbox Cleared**.

*When you select the **Inbox** and it contains no text messages, the display shows **List Empty**, and sounds a low tone if **Keypad Tones** are turned on (see **Turning Keypad Tones On or Off** on page 54).*

NOTE: Additional text messaging features are available with a keypad-enabled microphone. Refer to **Text Messaging** on page 58 for more details.

See **Audio** on page 64 or visit the following website for a list of Motorola-approved microphones:
<http://www.motorola.com/governmentandenterprise>

■ Privacy

If enabled, this feature helps to prevent eavesdropping by unauthorized users on a channel by the use of a software-based scrambling solution. The signaling and user identification portions of a transmission are not scrambled.

Your radio must have privacy enabled on the channel to send a privacy-enabled transmission, although this is not a necessary requirement for receiving a transmission. While on a privacy-enabled channel, the radio is still able to receive clear (unscrambled) transmissions.

To unscramble a privacy-enabled call or data transmission, your radio must have the same Privacy Key (programmed by your dealer) as the transmitting radio. If your radio receives a scrambled call that is of a different Privacy Key, you will hear a garbled transmission.

The green LED lights up while the radio is transmitting and blinks rapidly when the radio is receiving an ongoing privacy-enabled transmission.











NOTE: Some radio models may not offer this Privacy feature. Check with your dealer or system administrator for more information.

Procedure:

Press the programmed **Privacy** button to toggle privacy on or off.

OR

Follow the procedure below.

- 1 Press  to access the menu.
- 2 Press  or  to **Utilities** and press  to select.
- 3 Press  or  to **Radio Settings** and press  to select.
- 4 Press  or  to **Privacy** and press  to select.
- 5 The display shows **Privacy** and **Turn On**. Press  to enable privacy. The display shows **Privacy On**.

OR

The display shows **Privacy** and **Turn Off**. Press  to disable privacy. The display shows **Privacy Off**.

When privacy is enabled, the Home screen shows the Privacy icon, except when the radio is sending or receiving an Emergency call or alarm.

Security 



You can enable or disable any radio in the system. For example, you might want to disable a stolen radio, to prevent the thief from using it, and enable that radio, when it is recovered.

NOTE: Performing **Radio Disable** and **Enable** is limited to radios with these functions enabled.

 **Radio Disable**

Procedure:











Using the programmed **Radio Disable** button.

- 1 Press the programmed **Radio Disable** button.
- 2 Press  or  to the required subscriber alias or ID and press  to select.
- 3 The display shows **Radio Disable: <Subscriber Alias or ID>** and the green LED lights up.
- 4 Wait for acknowledgment.
- 5 If successful, a tone sounds and the display shows **Radio Disable Successful**.
OR
If not successful, a tone sounds and the display shows **Radio Disable Failed**.

OR

Procedure:

Using the menu.

- 1  to access the menu.
- 2  or  to **Contacts** and press  to select. The entries are alphabetically sorted.
- 3  or  to the required subscriber alias or ID and press  to select.
- 4  or  to **Radio Disable** and press  to select. The green LED blinks.
- 5 The display shows **Radio Disable: <Subscriber Alias or ID>** and the green LED lights up.
- 6 Wait for acknowledgment.
- 7 If successful, a tone sounds and the display shows **Radio Disable Successful**.

OR

If not successful, a tone sounds and the display shows **Radio Disable Failed**.



Do not press  during the Radio Disable operation as you will not get an acknowledgement message.

*You can also access this feature using manual dial (see **Radio Disable via Manual Dial** on page 62).*

 **Radio Enable**

Procedure:

Using the programmed **Radio Enable** button.

- 1 Press the programmed **Radio Enable** button.
- 2  or  to the required subscriber alias or ID and press  to select.
- 3 The display shows **Radio Enable: <Subscriber Alias or ID>** and the green LED lights up.
- 4 Wait for acknowledgment.
- 5 If successful, a tone sounds and the display shows **Radio Enable Successful**.





OR







If not successful, a tone sounds and the display shows **Radio Enable Failed**.

OR

Procedure:

Using the menu.

- 1  to access the menu.
- 2  or  to **Contacts** and press  to select. The entries are alphabetically sorted.

- 3  or  to the required subscriber alias or ID and press  to select.
- 4  or  to Radio Enable and press  to select. The green LED blinks.
- 5 The display shows Radio Enable: <Subscriber Alias or ID> and the green LED lights up.
- 6 Wait for acknowledgment.
- 7 If successful, a tone sounds and the display shows Radio Enable Successful.
OR
If not successful, a tone sounds and the display shows Radio Enable Failed.

Do not press  during the Radio Enable operation as you will not get an acknowledgement message.

You can also access this feature using manual dial (see **Radio Enable via Manual Dial** on page 62).

■ Utilities

Setting the Squelch Level

You can adjust your radio's squelch level to filter out unwanted calls with low signal strength or channels that have a higher than normal background noise.











Settings: Normal is the default. Tight filters out (unwanted) calls and/or background noise. However, calls from remote locations may also be filtered out.

Procedure:

Press the programmed **Squelch** button to toggle squelch level between normal and tight.

OR

Follow the procedure below.

- 1  to access the menu.
- 2  or  to Utilities and press  to select.
- 3  or  to Radio Settings and press  to select.
- 4  or  to Squelch and press  to select.
- 5 Choose either Tight or Normal and press  to select.
- 6 Screen returns to the previous menu.

 **Setting the Power Level**

You can customize your radio's power setting to high or low for each channel.











Settings: High enables communication with radios located at a considerable distance from you. Low enables communication with radios in closer proximity.

Procedure:

Press the programmed **Power Level** button to toggle transmit power level between high and low.

OR

Follow the procedure below.

- 1  to access the menu.
- 2  or  to Utilities and press  to select.
- 3  or  to Radio Settings and press  to select.
- 4  or  to Power and press  to select.
- 5 Change your current setting as prompted on the display.
- 6 Press  to select a new power level.
- 7 Screen returns to the previous menu.

Long press  to return to the Home screen. The power level icon is visible.

 **Turning the Option Board Feature(s) On or Off**

A channel can support up to 6 option board features. Refer to your dealer or system administrator for more information.

Procedure:

Press the programmed **Option Board Feature** button to toggle the feature on or off.

 **Turning the Public Address System On or Off**

You can enable and disable the radio's internal public address (PA) system.

Procedure:

Press the programmed **PA On/Off** button to toggle the feature on or off.

 **Turning the External Public Address System On or Off**

You can enable or disable the audio routing between the connected public address (PA) loudspeaker amplifier and the radio's internal public address (PA) system.

Procedure:

Press the programmed **Ext PA On/Off** button to toggle the feature on or off.

Controlling the Display Backlight













You can set the radio's display backlight intensity to either Low, Medium, High, or Off, to light up the display and the Menu Navigation Buttons backlighting accordingly. The setting also affects the keypad backlighting on a keypad microphone.

Procedure:

Press the programmed **Backlight** button to set the backlight intensity. Each press changes the display backlight setting to a new setting.

OR

Follow the procedure below.

- 1  to access the menu.
- 2  or  to Utilities and press  to select.
- 3  or  to Radio Settings and press  to select.
- 4  or  to Backlight and press  to select.
- 5 A ✓ indicates the current setting.
- 6  or  to the required setting and press  to select.
- 7 The display lights up accordingly and the screen returns to the previous menu.

*The display backlight, buttons and/or keypad backlighting are automatically turned off if the LED indicators are disabled (see **Turning the LED Indicators On or Off** on page 50).*

Turning Horns/Lights On or Off

Your radio is able to notify you of an incoming call via the horns and lights feature. When activated, an incoming call sounds your vehicle's horn and turns on its lights.













This feature needs to be installed through your radio's rear accessory connector by your dealer.

Procedure:

Press the programmed **Horns/Lights** button to toggle horns and lights feature on or off.

OR

Follow the procedure below.

- 1  to access the menu.
- 2  or  to Utilities and press  to select.
- 3  or  to Radio Settings and press  to select.
- 4  or  to Horns/Lights and press  to select.
- 5 The display shows Turn On. Press  to enable the horns and lights feature. The display shows Horns and Lights On.
OR
The display shows Turn Off. Press  to disable the horns and lights feature. The display shows Horns and Lights Off.

 **Turning Radio Tones/Alerts On or Off**















You can enable and disable all radio tones and alerts (except for the incoming Emergency alert tone) if needed.

Procedure:

Press the programmed **All Tones/Alerts** button to toggle all tones on or off.

OR















Follow the procedure below.

- 1  to access the menu.
- 2  or  to Utilities and press  to select.
- 3  or  to Radio Settings and press  to select.
- 4  or  to Tones/Alerts and press  to select.
- 5  or  to All Tones and press  to select.
- 6 The display shows Turn On. Press  to enable all tones and alerts. The display shows All Tones On.
OR
The display shows Turn Off. Press  to disable all tones and alerts. The display shows All Tones Off.

 **Turning the Talk Permit Tone On or Off**

You can enable and disable the Talk Permit Tone if needed.







Procedure:

- 1  to access the menu.
- 2  or  to Utilities and press  to select.
- 3  or  to Radio Settings and press  to select.
- 4  or  to Tones/Alerts and press  to select.
- 5  or  to Talk Permit and press  to select.
- 6 Select Turn On. Press  to enable the Talk Permit Tone. The display shows Talk Permit Tone On.
OR
Select Turn Off. Press  to disabled the Talk Permit Tone. The display shows Talk Permit Tone Off.

 **Turning the LED Indicators On or Off**

You can enable and disable the LED Indicators if needed.

Procedure:

- 1  to access the menu.
- 2  or  to Utilities and press  to select.
- 3  or  to Radio Settings and press  to select.

- 4 or to LED Indicator and press to select.
- 5 Select Turn On. Press to enable the LED Indicators. The display shows ALL LEDs On.
OR
Select Turn Off. Press to disable the LED Indicators. The display shows ALL LEDs Off.

The display backlight, buttons and/or keypad backlighting are automatically turned off if the LED Indicators are disabled (see **Controlling the Display Backlight** on page 49).

Turning the Introduction Screen On or Off

You can enable and disable the Introduction Screen if needed.

Procedure:

- 1 to access the menu.
- 2 or to Utilities and press to select.
- 3 or to Radio Settings and press to select.
- 4 or to Intro Screen and press to select.
- 5 The display shows Turn On. Press to enable the Introduction Screen. The display shows Intro Screen On.
OR
The display shows Turn Off. Press to disable the Introduction Screen. The display shows Intro Screen Off.

Accessing General Radio Information

Your radio contains information on the following:

- Radio ID
- Software Version
- Codeplug Version

NOTE: Press at any time to return to the previous screen or long press to return to the Home screen.

Checking the Radio ID

Displays the ID of your radio.











Procedure:

- 1 to access the menu.
- 2 or to Utilities and press to select.
- 3 or to Radio Info and press to select.
- 4 or to My Number and press to select.
- 5 The radio ID is displayed.

Checking the Firmware Version

Displays the firmware version on your radio.









Procedure:

- 1  to access the menu.
- 2  or  to Utilities and press  to select.
- 3  or  to Radio Info and press  to select.
- 4  or  to Firmware Ver., and press  to select.
- 5 The current firmware version is displayed.

Checking the Codeplug Version

Displays the codeplug version on your radio.

Procedure:

- 1  to access the menu.
- 2  or  to Utilities and press  to select.
- 3  or  to Radio Info and press  to select.
- 4  or  to CP Ver., and press  to select.
- 5 The current codeplug version is displayed.

Keypad Microphone Features

The following additional features for your radio are available with a keypad-enabled microphone:

- Using the Keypad page 53
- Additional Advanced Features. page 54
- Text Messaging page 58
- Security page 62

Keypad Microphone Features

Using the Keypad















You can use the 3 x 4 alphanumeric keypad on the keypad microphone (Motorola part number: RMN5065_) to access your radio's features. You can use the keypad to enter subscriber aliases or IDs, and text messages. Many characters require that you press a key multiple times. The table below shows the number of times a key needs to be pressed to generate the required character.

Key	Number of Times Key is Pressed												
	1	2	3	4	5	6	7	8	9	10	11	12	13
1 [?]	1	.	,	?	!	@	&	'	%	-	:	*	#
2 ^{abc}	A	B	C	2									
3 ^{def}	D	E	F	3									
4 ^{ghi}	G	H	I	4									
5 ^{jkl}	J	K	L	5									
6 ^{mnp}	M	N	O	6									
7 ^{qrst}	P	Q	R	S	7								
8 ^{uvw}	T	U	V	8									
9 ^{wxyz}	W	X	Y	Z	9								
0 ⁺	0	NOTE: Press to enter "0" and long press to activate the CAPS lock. Another long press to turn off the CAPS lock.											
* ^{del}	* or del	NOTE: Press during text entry to delete the character. Press during numeric entry to enter a "****".											
# [—]	# or space	NOTE: Press during text entry to insert a space. Press during numeric entry to enter a "#".											

Turning Keypad Tones On or Off

You can enable and disable Keypad Tones if needed.













Procedure:

- 1  to access the menu.
- 2  or  to Utilities and press  to select.
- 3  or  to Radio Settings and press  to select.
- 4  or  to Tones/Alerts and press  to select.
- 5  or  to Keypad Tones and press  to select.
- 6 The display shows Turn On. Press  to enable keypad tones. The display shows Keypad Tone On.
OR
 The display shows Turn Off. Press  to disable keypad tones. The display shows Keypad Tone Off.

Additional Advanced Features













Initiating a Radio Check by Manual Dial



Procedure:

- 1  to access the menu.
- 2  or  to Contacts and press  to select.
- 3  or  to Manual Dial and press  to select.
- 4 If there is a previously dialed subscriber ID, the ID appears along with a blinking cursor.
 Use the keypad to edit the ID. Press  to select.
OR
 Use the keypad to enter a new subscriber ID. Press  to select.
- 5  or  to Radio Check and press  to select.
- 6 The display shows Radio Check: <Subscriber ID>, indicating that Radio Check is in progress. The green LED lights up.







Keypad Microphone Features

- 7 Wait for acknowledgement.
 - 8 If the target radio is active in the system, a tone sounds and the display briefly shows **Target Radio Available**.
OR
If the target radio is not active in the system, a tone sounds and the display briefly shows **Target Radio Not Available**.
 - 9 Radio returns to the subscriber ID screen.

If the  button is pressed when the radio is waiting for acknowledgement, a tone sounds, and the radio terminates all retries and exits Radio Check mode.
- ### Initiating Remote Monitor by Manual Dial
- Procedure:**
- 1  to access the menu.
 - 2  or  to **Contacts** and press  to select.
 - 3  or  to **Manual Dial** and press  to select.
- 4 If there is a previously dialed subscriber ID, the ID appears along with a blinking cursor.
Use the keypad to edit the subscriber ID. Press  to select.
OR
Use the keypad to enter a new subscriber ID. Press  to select.
 - 5  or  to **Remote Mon.** and press  to select.
 - 6 Wait for acknowledgement.
 - 7 The display shows **Remote Monitor Successful**.
OR
The display shows **Remote Monitor Failed**.
 - 8 If successful:
Once the timer expires, the radio sounds an alert tone and the green LED turns off. The display shows **Remote Monitor Ended**.
OR
If unsuccessful:
The radio repeats the attempt until the programmed number of tries expires.

 **Making a Private Call by Manual Dial** 

Procedure:

- 1  to access the menu.
- 2  or  to **Contacts** and press  to select. The entries are alphabetically sorted.
- 3  or  to **Manual Dial** and press  to select.
- 4 If there is a previously dialed subscriber ID, the ID appears along with a blinking cursor. Use the keypad to edit the subscriber ID.
OR
Use the keypad to enter a new subscriber ID.
- 5 Press the **PTT** button to make the call. The green LED lights up. The first line displays the target radio's ID. The second line displays **Private Call** and the Private Call icon.
- 6 Wait for the Talk Permit Tone to finish (if enabled) and speak clearly into the microphone.
- 7 Release the **PTT** button to listen. When the target radio responds, the green LED blinks.

- 8 If the Channel Free Indication feature is enabled, you will hear a short alert tone the moment the target radio releases the **PTT** button, indicating the channel is free for you to respond. Press the **PTT** button to respond.
OR
If there is no voice activity for a programmed period of time, the call ends.





- 9 You hear a short tone. The display shows **Call Ended**.

 **Making a Private Call by Alias Search** 

















You can also use alias or alphanumeric search to retrieve the required subscriber alias.

This feature is only applicable while in Contacts.

Procedure:











- 1  to access the menu.
- 2  or  to **Contacts** and press  to select. The entries are alphabetically sorted.
- 3 Key in the first character of the alias.

Keypad Microphone Features



- 4  or  to the required alias.
 - 5 Press the **PTT** button to make the call. The green LED lights up. The first line displays the target radio's ID. The second line displays **Private Call** and the **Private Call** icon.
 - 6 Wait for the **Talk Permit Tone** to finish (if enabled) and speak clearly into the microphone
 - 7 Release the **PTT** button to listen. When the target radio responds, the green LED blinks.
 - 8 If the **Channel Free Indication** feature is enabled, you will hear a short alert tone the moment the target radio releases the **PTT** button, indicating the channel is free for you to respond. Press the **PTT** button to respond.
OR
If there is no voice activity for a programmed period of time, the call ends.
 - 9 You hear a short tone. The display shows **Call Ended**.
-  **Storing an Alias or ID from the Missed Call List**
- Procedure:**
- 1  to access the menu.
 - 2  or  to **Call Log** and press  to select.
 - 3  or  to **Missed** and press  to select.
 - 4  or  to the required missed call alias or ID and press  to select.
 - 5  or  to **Store** and press  to select.
 - 6 A blinking cursor appears. If needed, key in the alias for that ID and press .
 - 7 The display shows **Contact Saved**.
- You can also store an ID without an alias.*

Making a Call Alert by Manual Dial

Procedure:

- 1  to access the menu.
- 2  or  to **Contacts** and press  to select.
- 3  or  to **Manual Dial** and press  to select.
- 4 A blinking cursor appears. Enter the subscriber ID you want to send the Call Alert to and press .
- 5  or  to **Call Alert** and press  to select.
- 6 The display shows **Call Alert: <Subscriber ID>**, confirming that the Call Alert has been sent.
- 7 The green LED lights up when your radio is sending the Call Alert.
- 8 If the Call Alert acknowledgement is received, a tone sounds and the display shows **Call Alert Successful**.
OR
If the Call Alert acknowledgement is not received, a tone sounds and the display shows **Call Alert Failed**.

Text Messaging

NOTE: Press  at any time to return to the previous screen or long press  to return to the Home screen.

Writing and Sending a Text Message









The maximum length of characters for a text message is 140.

Procedure:

Press the programmed **Text Messaging** button and proceed to step 3.

OR

Follow the procedure below.

- 1  to access the menu.
- 2  or  to **Messages** and press  to select.
- 3  or  to **Write** and press  to select.
- 4 Use the keypad to type your message.
Press  to move one space to the left.
Press  or the # key to move one space to the right.
Press the * key to delete any unwanted characters.

- 5 Press **OK** once message is composed.
- 6 **◀** or **▶** to the required subscriber alias or ID and press **OK** to select.
OR
▶ or **▶** to Manual Dial and press **OK** to select.
 Key in the subscriber ID and press **OK**.
- 7 The display shows Text Message: <Subscriber Alias or ID>, confirming your message is being sent.
- 8 If the message is sent, a tone sounds and the display shows Message Sent.
OR
 If the message is not sent, the display shows Message Send Failed.

*If the message fails to send, the radio returns you to the Resend option screen (see **Managing Fail-to-Send Text Messages** on page 61 and page 61).*

Replaying to Text Messages from the Inbox

Procedure:

Press the programmed **Text Messaging** button and proceed to step 3.

OR

Follow the procedure below.

- 1 **Menu** to access the menu.
- 2 **◀** or **▶** to Messages and press **OK** to select.
- 3 **◀** or **▶** to Inbox and press **OK** to select.
- 4 **◀** or **▶** to the required message and press **OK** to select.
- 5 Press **OK** once more to access additional options.
- 6 **◀** or **▶** to Reply and press **OK** to select.
- 7 **◀** or **▶** to Write and press **OK** to select.
 A blinking cursor appears. Use the keypad to type your message.
 Press **◀** to move one space to the left.
 Press **▶** or the # key to move one space to the right.
 Press the * key to delete any unwanted characters.

Keypad Microphone Features

- 8 Press **OK** once message is composed.
- 9 The display shows **Text Message: <Subscriber/Group Alias or ID>**, confirming your message is being sent.
- 10 If the message is sent, a tone sounds and the display shows **Message Sent**.
OR
If the message is not sent, a tone sounds and the display shows **Message Send Failed**.







*If the message fails to send, the radio returns you to the **Resend** option screen (see **Managing Fail-to-Send Text Messages** on page 38 and page 61).*







Editing a Quick Text Message

Procedure:
Press the programmed **Text Messaging** button and proceed to step 3.

OR

Follow the procedure below.

- 1  to access the menu.
- 2  or  to **Messages** and press **OK** to select.
- 3  or  to **Quick Text** and press **OK** to select.
- 4  or  to the required **Quick Text** and press **OK** to select.

- 5 A blinking cursor appears. Use the keypad to edit the message.
Press  to move one space to the left.
Press  or the # key to move one space to the right.
Press the * key to delete any unwanted characters.
- 6 Press **OK** once message is composed.
- 7  or  to the required subscriber alias or ID and press **OK** to select.
OR
 or  to **Manual Dial** and press **OK** to select.
Key in the subscriber ID and press **OK**.
- 8 The display shows **Text Message: <Subscriber Alias or ID>**, confirming your message is being sent.
- 9 If the message is sent, a tone sounds and the display shows **Message Sent**.
OR
If the message is not sent, a tone sounds and the display shows **Message Send Failed**.

*If the message fails to send, the radio returns you to the **Resend** option screen (see **Managing Fail-to-Send Text Messages** on page 38 and page 61).*







Managing Fail-to-Send Text Messages

if the message fails to send, the radio returns you to the **Resend** option screen.

Forwarding a Text Message by Manual Dial

Select **Forward** to send the message to another subscriber/group alias or ID.













Procedure:

- 1  or  to **Forward** and press  to select.
- 2  or  to **Manual Dial** and press  to select.
Key in the subscriber ID and press .
- 3 The display shows **Text Message: <Subscriber/Group Alias or ID>**, confirming your message is being sent.
- 4 If the message is sent, a tone sounds and the display shows **Message Sent**.
OR
If the message is not sent, a low tone sounds and the display shows **Message Send Failed**.

Editing a Text Message

Select **Edit** to edit the message before sending it.

Procedure:











- 1  or  to **Edit** and press  to select.
- 2 A blinking cursor appears beside the message.
Use the keypad to edit your message.
Press  to move one space to the left.
Press  or the # key to move one space to the right.
Press the *DEL key to delete any unwanted characters.
- 3 Press  once message is composed.
- 4  or  to the required alias or ID and press  to select.
OR
 or  to **Manual Dial** and press  to select.
Key in the subscriber ID and press .
- 5 The display shows **Text Message: <Subscriber/Group Alias or ID>**, confirming your message is being sent.
- 6 If the message is sent, a tone sounds and the display shows **Message Sent**.
OR
If the message is not sent, a low tone sounds and the display shows **Message Send Failed**.

Keypad Microphone Features

Security

Radio Disable via Manual Dial











Procedure:

- 1  to access the menu.
- 2  or  to Contacts and press  to select. The entries are alphabetically sorted.
- 3  or  to Manual Dial and press  to select. Key in the subscriber ID and press .
- 4  or  to Radio Disable and press  to select. The green LED blinks.
- 5 The display shows Radio Disable: <Subscriber ID> and the green LED lights up.
- 6 Wait for acknowledgment.
- 7 If successful, a tone sounds and the display shows Radio Disable Successful.
OR
If not successful, a tone sounds and the display shows Radio Disable Failed.

Do not press  during the Radio Disable operation as you will not get an acknowledgement message.

Radio Enable via Manual Dial

Procedure:

- 1  to access the menu.
- 2  or  to Contacts and press  to select. The entries are alphabetically sorted.
- 3  or  to Manual Dial and press  to select. Key in the subscriber ID and press .
- 4  or  to Radio Enable and press  to select. The green LED blinks.
- 5 The display shows Radio Enable: <Subscriber ID> and the green LED lights up.
- 6 Wait for acknowledgment.
- 7 If successful, a tone sounds and the display shows Radio Enable Successful.
OR
If not successful, a tone sounds and the display shows Radio Enable Failed.

Do not press  during the Radio Enable operation as you will not get an acknowledgement message.

Accessories

Your radio is compatible with the accessories listed in this chapter. Contact your dealer for details.

Antennas	page 63
Audio	page 64
Cables	page 64
Desktop Accessories	page 65
Mounting Kits	page 65
Speakers	page 65
Miscellaneous Accessories	page 65

Antennas

- VHF, 136 – 144 MHz, 1/4 Wave, Through-Hole Mount, Mini-U (HAD4006_)
- VHF, 146 – 150.8 MHz, 1/4 Wave, Through-Hole Mount, Mini-U (HAD4007_)
- VHF, 150.8 – 162 MHz, 1/4 Wave, Through-Hole Mount, Mini-U (HAD4008_)
- VHF, 162 – 174 MHz, 1/4 Wave, Through-Hole Mount, Mini-U (HAD4009_)
- VHF, 146 – 172 MHz, 3.0 dB Gain, Through-Hole Mount, Mini-U (HAD4014_)

- UHF, 403 – 430 MHz, 1/4 Wave, Through-Hole Mount, Mini-U (HAE4002_)
- UHF, 450 – 470 MHz, 1/4 Wave, Through-Hole Mount, Mini-U (HAE4003_)
- UHF, 470 – 527 MHz, 1/4 Wave, Through-Hole Mount, Mini-U (HAE4004_)
- UHF, 406 – 420 MHz, 3.5 dB Gain, Through-Hole Mount, Mini-U (HAE4010_)
- UHF, 450 – 470 MHz, 3.5 dB Gain, Through-Hole Mount, Mini-U (HAE4011_)
- UHF, 470 – 494 MHz, 3.5 dB Gain, Through-Hole Mount, Mini-U (HAE4012_)
- UHF, 494 – 512 MHz, 3.5 dB Gain, Through-Hole Mount, Mini-U (HAE4013_)
- UHF, 403 – 527 MHz, 2.0 dB Gain, Through-Hole Mount, Mini-U (HAE6022_)
- UHF, 450 – 470 MHz, 5.0 dB Gain, Through-Hole Mount, Mini-U (RAE4004_)

For XPR 4550 GPS Models Only

- Combination GPS/VHF, 136 – 144 MHz, 1/4 Wave, Through-Hole Mount, Mini-U (RAD4214_)
- Combination GPS/VHF, 146 – 150.8 MHz, 1/4 Wave, Through-Hole Mount, Mini-U (RAD4215_)

- Combination GPS/VHF, 150.8 – 162 MHz, 1/4 Wave, Through-Hole Mount, Mini-U (RAD4216_)
- Combination GPS/VHF, 162 – 174 MHz, 1/4 Wave, Through-Hole Mount, Mini-U (RAD4217_)
- Combination GPS/VHF, 146 – 172 MHz, 3.0 dB Gain, Through-Hole Mount, Mini-U (RAD4218_)
- Combination GPS/UHF, 403 – 527 MHz, 2.0 dB Gain, Through-Hole Mount, Mini-U (HAE6019_)
- Combination GPS/UHF, 470 – 527 MHz, 1/4 Wave, Through-Hole Mount, Mini-U (HAE6020_)
- Combination GPS/UHF, 470 – 494 MHz, 3.0 dB Gain, Through-Hole Mount, Mini-U (HAE6024_)
- Combination GPS/UHF, 494 – 512 MHz, 3.0 dB Gain, Through-Hole Mount, Mini-U (HAE6026_)
- Combination GPS/UHF, 403 – 430 MHz, 1/4 Wave, Through-Hole Mount, Mini-U (PMAE4030_)
- Combination GPS/UHF, 450 – 470 MHz, 1/4 Wave, Through-Hole Mount, Mini-U (PMAE4031_)
- Combination GPS/UHF, 406 – 420 MHz, 3.5 dB Gain, Through-Hole Mount, Mini-U (PMAE4032_)
- Combination GPS/UHF, 450 – 470 MHz, 3.5 dB Gain, Through-Hole Mount, Mini-U (PMAE4033_)
- Combination GPS/UHF, 450 – 470 MHz, 5.0 dB Gain, Through-Hole Mount, Mini-U (PMAE4034_)

Accessories

64

- Fixed Mount GPS Active Antenna (PMAN4000_)
- Window Mount GPS Active Antenna (PMAN4001_)
- Magnetic Mount GPS Active Antenna (PMAN4002_)

Audio

- Telephone Style Handset (HMN4098_)
- Desktop Microphone (RMN5050_)
- Compact Microphone (RMN5052_)
- Heavy Duty Microphone with Enhanced Audio (RMN5053_)
- Visor Microphone with Enhanced Audio (RMN5054_)
- Keypad Microphone with Enhanced Audio (RMN5065_)

Cables

- Power Cable to Battery, 10-foot (3-metre) Cable, 15 amp (1 – 25 Watt) (HKN4137_)
- Power Cable to Battery, 10-foot (3-metre) Cable, 20 amp (1 – 45 Watt) (HKN4191_)
- Power Cable to Battery, 20-foot (6-metre) Cable, 20 amp (1 – 45 Watt) (HKN4192_)
- Mobile and Repeater Rear Accessory Connector Universal Cable (PMKN4018_)

- Ignition Sense Cable (RKN4136_)

■ Desktop Accessories

- Radio Power Cable for GPN6145 (GKN6266_)
- Desktop Tray without Speaker (GLN7318_)
- Desktop Tray with Speaker (RSN4005_)
- Switchmode Power Supply (1 – 25 Watt Models) (CE marked) (GPN6145_)
- Mobile Mini-U Antenna Adapter, 8-foot (2.4-metre) Cable (HKN9088_)
- Power Supply and Cable (25 – 60 Watt Models) (HPN4007_)
- Power Supply and Cable (1 – 25 Watt Models) (HPN4008_)
- Hardware Kit for Rear Accessory Connector (PMLN5072_)

■ Mounting Kits

- In Dash (DIN) Mounting Kit (RLN5933_)
- Low Profile Trunnion Kit (RLN6077_)
- High Profile Trunnion Kit (RLN6078_)
- Key Lock Trunnion Kit (RLN6079_)

■ Speakers

- 13-Watt External Speaker (RSN4002_)
- 7.5-Watt External Speaker (RSN4003_)
- 5-Watt External Speaker (RSN4004_)

■ Miscellaneous Accessories

- Display Mobile Button Kit (Includes Buttons for Monitor, Scan, Backlight, Emergency, Talkaround, Text Message, and Contacts) (HKLN4291_)
- Mobile Button Kit (Includes Buttons for Remote Monitor, Radio Check, Radio Disable, and VOX) (HKLN4292_)
- PL259/Mini-U Antenna Adapter, 8-foot (2.4-metre) Cable (HKN9557_)
- Microphone Hang Up Clip (All Microphones) (HLN9073_)
- Universal Microphone Hang Up Clip (All Microphones) (HLN9414_)
- Push Button **PTT** (RLN5926_)
- Emergency Footswitch (RLN5929_)

Accessories

Limited Warranty

MOTOROLA COMMUNICATION PRODUCTS

I. WHAT THIS WARRANTY COVERS AND FOR HOW LONG:

MOTOROLA INC. ("MOTOROLA") warrants the MOTOROLA manufactured Communication Products listed below ("Product") against defects in material and workmanship under normal use and service for a period of time from the date of purchase as scheduled below:

XPR Series Digital Mobile Radios	Two (2) Years
Product Accessories	One (1) Year

MOTOROLA, at its option, will at no charge either repair the Product (with new or reconditioned parts), replace it (with a new or reconditioned Product), or refund the purchase price of the Product during the warranty period provided it is returned in accordance with the terms of this warranty. Replaced parts or boards are warranted for the balance of the original applicable warranty period. All replaced parts of Product shall become the property of MOTOROLA.

This express limited warranty is extended by MOTOROLA to the original end user purchaser only and is not assignable or transferable to any other party. This is the complete warranty for the Product manufactured by MOTOROLA. MOTOROLA assumes no

obligations or liability for additions or modifications to this warranty unless made in writing and signed by an officer of MOTOROLA.

Unless made in a separate agreement between MOTOROLA and the original end user purchaser, MOTOROLA does not warrant the installation, maintenance or service of the Product.

MOTOROLA cannot be responsible in any way for any ancillary equipment not furnished by MOTOROLA which is attached to or used in connection with the Product, or for operation of the Product with any ancillary equipment, and all such equipment is expressly excluded from this warranty. Because each system which may use the Product is unique, MOTOROLA disclaims liability for range, coverage, or operation of the system as a whole under this warranty.

II. GENERAL PROVISIONS:

This warranty sets forth the full extent of MOTOROLA'S responsibilities regarding the Product. Repair, replacement or refund of the purchase price, at MOTOROLA'S option, is the exclusive remedy. THIS WARRANTY IS GIVEN IN LIEU OF ALL OTHER EXPRESS WARRANTIES. IMPLIED WARRANTIES, INCLUDING WITHOUT LIMITATION, IMPLIED WARRANTIES OF MERCHANTABILITY AND FITNESS FOR A PARTICULAR PURPOSE, ARE LIMITED TO THE DURATION OF THIS LIMITED WARRANTY. IN NO EVENT SHALL MOTOROLA BE LIABLE FOR DAMAGES IN EXCESS OF THE PURCHASE PRICE OF THE PRODUCT, FOR ANY LOSS OF USE, LOSS OF TIME, INCONVENIENCE, COMMERCIAL LOSS, LOST PROFITS OR SAVINGS OR OTHER INCIDENTAL, SPECIAL OR CONSEQUENTIAL DAMAGES ARISING OUT OF THE USE OR

INABILITY TO USE SUCH PRODUCT, TO THE FULL EXTENT SUCH MAY BE DISCLAIMED BY LAW.

III. STATE LAW RIGHTS:

SOME STATES DO NOT ALLOW THE EXCLUSION OR LIMITATION OF INCIDENTAL OR CONSEQUENTIAL DAMAGES OR LIMITATION ON HOW LONG AN IMPLIED WARRANTY LASTS, SO THE ABOVE LIMITATION OR EXCLUSIONS MAY NOT APPLY.

This warranty gives specific legal rights, and there may be other rights which may vary from state to state.

IV. HOW TO GET WARRANTY SERVICE:

You must provide proof of purchase (bearing the date of purchase and Product item serial number) in order to receive warranty service and, also, deliver or send the Product item, transportation and insurance prepaid, to an authorized warranty service location. Warranty service will be provided by MOTOROLA through one of its authorized warranty service locations. If you first contact the company which sold you the Product (e.g., dealer or communication service provider), it can facilitate your obtaining warranty service. You can also call MOTOROLA at 1-800-927-2744 US/Canada.

V. WHAT THIS WARRANTY DOES NOT COVER:

- A) Defects or damage resulting from use of the Product in other than its normal and customary manner.
- B) Defects or damage from misuse, accident, water, or neglect.

- C) Defects or damage from improper testing, operation, maintenance, installation, alteration, modification, or adjustment.
- D) Breakage or damage to antennas unless caused directly by defects in material workmanship.

E) A Product subjected to unauthorized Product modifications, disassembles or repairs (including, without limitation, the addition to the Product of non-MOTOROLA supplied equipment) which adversely affect performance of the Product or interfere with MOTOROLA's normal warranty inspection and testing of the Product to verify any warranty claim.

F) Product which has had the serial number removed or made illegible.

G) Rechargeable batteries if:

- (1) any of the seals on the battery enclosure of cells are broken or show evidence of tampering.
- (2) the damage or defect is caused by charging or using the battery in equipment or service other than the Product for which it is specified.

H) Freight costs to the repair depot.

I) A Product which, due to illegal or unauthorized alteration of the software/firmware in the Product, does not function in accordance with MOTOROLA's published specifications or the FCC type acceptance labeling in effect for the Product at the time the Product was initially distributed from MOTOROLA.

J) Scratches or other cosmetic damage to Product surfaces that does not affect the operation of the Product.

K) Normal and customary wear and tear.

Limited Warranty

VI. PATENT AND SOFTWARE PROVISIONS:

MOTOROLA will defend, at its own expense, any suit brought against the end user purchaser to the extent that it is based on a claim that the Product or parts infringe a United States patent, and MOTOROLA will pay those costs and damages finally awarded against the end user purchaser in any such suit which are attributable to any such claim, but such defense and payments are conditioned on the following:

- A) that MOTOROLA will be notified promptly in writing by such purchaser of any notice of such claim;
- B) that MOTOROLA will have sole control of the defense of such suit and all negotiations for its settlement or compromise; and
- C) should the Product or parts become, or in MOTOROLA's opinion be likely to become, the subject of a claim of infringement of a United States patent, that such purchaser will permit MOTOROLA, at its option and expense, either to procure for such purchaser the right to continue using the Product or parts or to replace or modify the same so that it becomes non-infringing or to grant such purchaser a credit for the Product or parts as depreciated and accept its return. The depreciation will be an equal amount per year over the lifetime of the Product or parts as established by MOTOROLA.

MOTOROLA will have no liability with respect to any claim of patent infringement which is based upon the combination of the Product or parts furnished hereunder with software, apparatus or devices not furnished by MOTOROLA, nor will MOTOROLA have any liability for the use of ancillary equipment or software not furnished by MOTOROLA which is attached to or used in connection with the Product. The foregoing states the entire liability of MOTOROLA with respect to infringement of patents by the Product or any parts thereof.

Laws in the United States and other countries preserve for MOTOROLA certain exclusive rights for copyrighted MOTOROLA software such as the exclusive rights to reproduce in copies and distribute copies of such MOTOROLA software. MOTOROLA software may be used in only the Product in which the software was originally embodied and such software in such Product may not be replaced, copied, distributed, modified in any way, or used to produce any derivative thereof. No other use including, without limitation, alteration, modification, reproduction, distribution, or reverse engineering of such MOTOROLA software or exercise of rights in such MOTOROLA software is permitted. No license is granted by implication, estoppel or otherwise under MOTOROLA patent rights or copyrights.

VII. GOVERNING LAW:

This Warranty is governed by the laws of the State of Illinois, U.S.A.

MOTOROLA
XPR Series Digital Mobile Radios
Quick Reference Card

Radio Controls

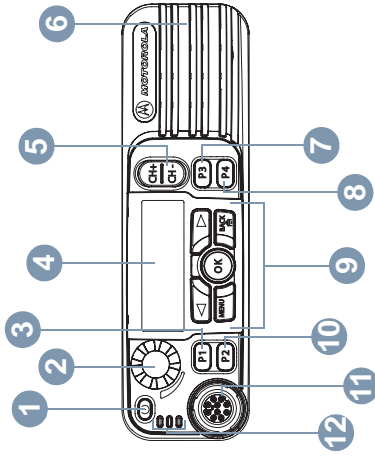

Record your radio's programmable button functions in the blanks provided. **SP** represents Short Press, **LP** represents Long Press.

- 1 On/Off Button

- 2 Volume Knob
- 3 **SP:** _____ **LP:** _____
Front Button P1 (Programmable)
- 4 Display
- 5 Channel Rocker
- 6 Speaker
- 7 **SP:** _____ **LP:** _____
Front Button P3 (Programmable)
- 8 **SP:** _____ **LP:** _____
Front Button P4 (Programmable)
- 9 Menu Navigation Buttons
- 10 **SP:** _____ **LP:** _____
Front Button P2 (Programmable)
- 11 Accessory Connector
- 12 LED Indicators

Menu Navigation Buttons

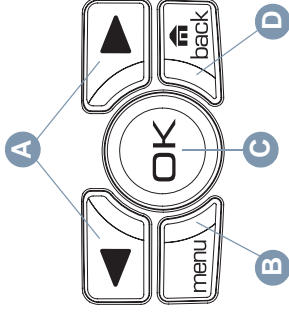

- A Left/Right Navigation Buttons
- B Menu Button
- C OK Button
- D Back/Home Button



6880309T08-D

English

■ Display Icons

The following are the icons that appear on the radio's display.



The number of bars displayed represents the radio signal strength. Four bars indicates the strongest signal. This icon is only displayed while receiving.



Selected channel is being monitored.



Radio is currently set at Low Power (L) or High Power (H).



Tones are set off.



The Option Board is enabled.



The Option Board is disabled.



The GPS feature is enabled. The icon stays lit when a position fix is available. ●



The GPS feature is enabled but is not receiving data from the satellite. ●



Scan feature is activated.



Radio recognizes activity on the channel/group designated as Priority 1 (if ● is blinking) or as Priority 2 (if ● is steady).



Unread message in the Inbox. ●



User's Inbox is full. ●



Radio is in Emergency mode.



The Privacy feature is enabled. ●



In the absence of a repeater, radio is currently configured for direct radio to radio communication.

■ Call Icons

The following icons appear on the radio's display during a call. These icons also appear in the Contacts list to indicate ID type.



Indicates a Private Call in progress. In Contacts list, it indicates a subscriber alias or ID.



Indicates a Group Call or All Call in progress. In Contacts list, it indicates a group alias or ID.

■ Sent Items Icons

The following icons appear at the top right corner of the radio's display in the Sent Items folder.



The text message is sent successfully.



The text message cannot be sent.



• The text message to a group alias or ID is pending transmission.

• The text message to a subscriber alias or ID is pending transmission, followed by waiting for acknowledgement.

■ LED Indicators

Blinking red – Radio is receiving an Emergency transmission or has failed the self-test upon powering up.

Solid yellow – Radio is receiving a request for a Private Call, or monitoring a channel.

Blinking yellow – Radio is scanning for activity or receiving a Call Alert.

Solid green – Radio is transmitting.

Blinking green – Radio is powering up, receiving a non-privacy-enabled call or data, or detecting activity over the air.

Rapidly blinking green – Radio is receiving a privacy-enabled call or data. ●

■ Powering the Radio On or Off

Press the On/Off Button briefly to turn on the radio, and press and hold the On/Off Button to turn it off.

■ Adjusting the Volume

Turn the Volume Knob clockwise to increase volume or counterclockwise to decrease volume.



■ Selecting a Zone

Press the programmed **Zone** button and proceed to step 3.

OR

Follow the procedure below.

1  to access the menu.

2  or  to **Zone** and press  to select.

3 The current zone is displayed and indicated by a ✓.

4  or  to the required zone and press  to select.

5 The display shows **<Zone> Selected** momentarily and returns to the selected zone screen.

■ Selecting a Radio Channel, Subscriber ID, or Group ID

1 Press the On/Off Button.

2 Press the Channel Rocker to select the required channel, subscriber ID, or group ID.

■ Making a Group Call

Press the programmed **One Touch Call** button and proceed to step 2.



OR



Follow the procedure below.

1 Press the Channel Rocker to select the channel with the active group alias or ID.

OR

 to access the menu.

 or  to **Contacts** and press  to select.

 or  to the ID you want to call and press  to select.

2 Press the **PTT** button to make the call. The green LED lights up. The display shows the group alias or ID, and the Group Call icon.

3 Wait for the Talk Permit Tone to finish (if enabled) and speak clearly into the microphone.

4 Release the **PTT** button to listen.

5 When the target radio responds, the green LED blinks. You see the Group Call icon, the group ID, and target radio ID on your display.

6 If the Channel Free Indication feature is enabled, you will hear a short alert tone the moment the target radio releases the **PTT** button, indicating the channel is free for you to respond. Press the **PTT** button to respond. 

OR

If there is no voice activity for a programmed period of time, the call ends.

To make a call to a group of users, your radio must be configured as part of that group.

 Your radio must have the **Privacy feature enabled on the channel to send a privacy-enabled transmission. Only target radios with the same Privacy Key as your radio will be able to unscramble the transmission.**

■ Making a Private Call

Press the programmed **One Touch Call** button and proceed to step 2.



OR



Follow the procedure below.

1 Press the Channel Rocker to select the channel with the active subscriber alias or ID.

OR

 to access the menu.

 or  to **Contacts** and press  to select.

 or  to the ID you want to call and press  to select.

2 Press the **PTT** button to make the call. The green LED lights up. The first line displays the target radio's ID. The second line displays **Private Call** and the Private Call icon.

3 Wait for the Talk Permit Tone to finish (if enabled) and speak clearly into the microphone.

- 4 Release the **PTT** button to listen.
- 5 If the Channel Free Indication feature is enabled, you will hear a short alert tone the moment the target radio releases the **PTT** button, indicating the channel is free for you to respond. Press the **PTT** button to respond.
OR
If there is no voice activity for a programmed period of time, the call ends.
- 6 You hear a short tone. The display shows **Call Ended**.
Your radio must have the Privacy feature enabled on the channel to send a privacy-enabled transmission. Only target radios with the same Privacy Key as your radio will be able to unscramble the transmission.

■ Making an All Call

Your radio must be programmed to allow you to use this feature. Users on the channel cannot respond to an All Call.

- 1 Press the Channel Rocker to select the channel with the active All Call group alias or ID.
- 2 Press the **PTT** button to make the call. The green LED lights up. The display shows the All Call group alias or ID, and the All Call icon

- 3 Wait for the Talk Permit Tone to finish (if enabled) and speak clearly into the microphone.

- 4 If there is no voice activity for a programmed period of time, the call ends.

When you receive an All Call, a message appears and remains on your radio's display until the call ends. You will not be able to continue with any menu navigation or editing until the call ends.





Once the All Call ends, the radio returns to the menu prior to receiving the call.

■ Scanning Channels

Press the programmed **Scan** button to turn scan on or off.

OR

Follow the procedure below.

- 1  to access the menu.
- 2  or  to **Scan** and press  to select.
- 3 You see **Scan On** or **Scan Off** depending on previous selection.











During scan, the yellow LED blinks and the scan icon is displayed.

■ Making a Call Alert

Press the programmed **One Touch Call** button and proceed to step 5.

OR

Follow the procedure below.

- 1  to access the menu.
- 2  or  to **Contacts**. Press  to select.
- 3  or  to the required subscriber alias or ID and press  to select.
- 4  or  to **Call Alert** and press  to select.

- 5 The display shows **Call Alert:**
<Subscriber Alias or ID>. The green LED lights up.

- 6 If the Call Alert acknowledgement is received, a tone sounds and the display shows **Call Alert Successful**.

OR

If the Call Alert acknowledgement is not received, a tone sounds and the display shows **Call Alert Failed**.

■ Sending a Quick Text Message

Press the programmed **Text Messaging** button and proceed to step 3.



OR



Press the programmed **One Touch Call** button to send a predefined Quick Text message to a predefined alias or ID and proceed to step 6.

OR

Follow the procedure below.

1  to access the menu.

2  or  to **Messages** and press  to select.

3  or  to **Quick Text** and press  to select.

4  or  to the required **Quick Text** and press  to select.

5  or  to the required alias or ID and press  to select.

6 The display shows **Text Message:**
<Subscriber/Group Alias or ID>.

7 If the message is sent successfully, a tone sounds and the display shows **Message Sent**.

OR

If the message cannot be sent, the display shows **Message Send Failed**.

If the message fails to send, the radio returns you to the *Resend* option screen.

- Press  to resend the message to the same subscriber/group alias or ID.

- Select *Forward* to send the message to another subscriber/group alias or ID.

- Select *Edit* to edit the message before sending it.

NOTE: Once a message is sent to another radio, it is saved in Sent Items. The most recent sent text message is always added to the top of the Sent Items list.

The Sent Items folder stores a maximum of thirty (30) last sent messages. When the folder is full, the next sent text message automatically replaces the oldest text message in the folder.

The icon at the top right corner of the screen indicates the status of the message.

■ Replying to a Text Message with



Quick Text from the Inbox

Press the programmed **Text Messaging** button and proceed to step 3.

OR

Follow the procedure below.



1  to access the menu.

2  or  to **Messages** and press  to select.

3  or  to **Inbox**. Press  to select.

4  or  to the required message and press  to select.

5 Press  once more to access the sub-menu.

6  or  to **Reply** and press  to select.

7  or  to **Quick Text** and press  to select.

8 Press  once more to send the reply.

9 The display shows **Text Message:**
<Subscriber/Group Alias or ID>.

10 If the message is sent successfully, a tone sounds. The display shows **Message Sent**.

OR

If the message cannot be sent, the display shows **Message Send Failed**.

If the message fails to send, the radio returns you to the *Resend* option screen.

- Press  to resend the message to the same subscriber/group alias or ID.

- Select *Forward* to send the message to another subscriber/group alias or ID.

- Select *Edit* to edit the message before sending it.

■ Sending an Emergency Alarm

- 1 Press the programmed **Emergency** button or the **Emergency** footswitch.
 - 2 The display shows **Sending Alarm**, which alternates with your radio ID. The green LED lights up and the Emergency icon appears on the Home screen display.
 - 3 When an Emergency Alarm acknowledgment is received, the Emergency tone sounds and the green LED blinks. The display shows **Emergency Alarm Successful**.
- OR**
- If your radio does not receive an Emergency Alarm acknowledgement, and after all retries have been exhausted, a tone sounds and the display shows **Emergency Alarm Failed**.
 - 4 Radio exits the Emergency Alarm mode and returns to the Home screen.













If your radio is set to Silent, it will not display any audio or visual indicators during Emergency mode.

■ Privacy

Press the programmed **Privacy** button to toggle privacy on or off.

OR

Follow the procedure below.

- 1  to access the menu.
 - 2  or  to Utilities. Press  to select.
 - 3  or  to Radio Settings. Press  to select.
 - 4  or  to Privacy. Press  to select.
 - 5 The display shows **Privacy and Turn On**. Press  to enable privacy. The display shows **Privacy On**.
- OR**
- 5 The display shows **Privacy and Turn On**. Press  to disable privacy. The display shows **Privacy Off**.



MOTOROLA

Motorola, Inc.
1301 E. Algonquin Rd.
Schaumburg, IL 60196-1078, U.S.A.

MOTOROLA and the Stylized M Logo are
registered in the U.S. Patent and Trademark Office.
All other product or service names are the property
of their respective owners.

© 2006 - 2008 by Motorola, Inc.
All rights reserved. Printed in the U.S.A.
February 2008

www.motorola.com/mototibo



6880309T15-D