

Introduction

The antennas described in this section are supplied with an appropriate antenna whip, coaxial cable and connector, and mounting hardware. Mounting hardware and installation are described for two different types of mounting:

- roof mount
- trunk lip mount

Refer to Table 1 for model identification. Figures 1 through 4 identify the component parts of the antenna. Refer to the recommendations for antenna location paragraph at the end of this instruction section for safety information.

ROD WITH CHROME NUT (ROD)	ANTENNA ONLY		
	MOTOROLA PART NO.	ANTENNA MODEL NO.	FREQ. RANGE (MHz)
01-80352A05	01-83938B01	HAD4006A	136-144
01-80352A06	01-83938B02	HAD4007A	144-150.8
01-80352A07	01-83938B03	HAD4008A	150.8-162
01-80352A08	01-83938B04	HAD4009A	162-174
01-80352A11	01-83938B06	HAE4003A	450-470
01-80352A90	01-83938B11	HAF4002A	806-870
01-80305J99	01-80305J98	HAF4012A	746-794

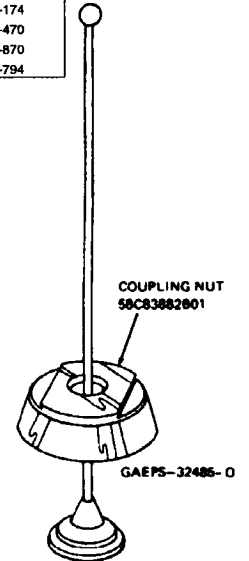

Figure 1. Whip Parts Identification

Table 1. Model Complement

Antenna Model	Frequency Range (MHz)
<i>Roof Mount Models</i>	
HAD4006A	136-144
HAD4007A	144-150.8
HAD4008A	150.8-162
HAD4009A	162-174
HAE4003A	450-470
HAF4002A	806-870
HAF4012A	746-794
<i>Trunk Lip Mount Models</i>	
HAD4010A	136-144
HAD4011A	144-150.8
HAD4012A	150.8-162
HAD4013A	162-174
HAE4007A	449-470
HAF4003A	806-870

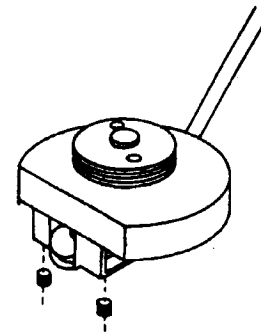

Figure 2. Antenna Trunk Lip Mount



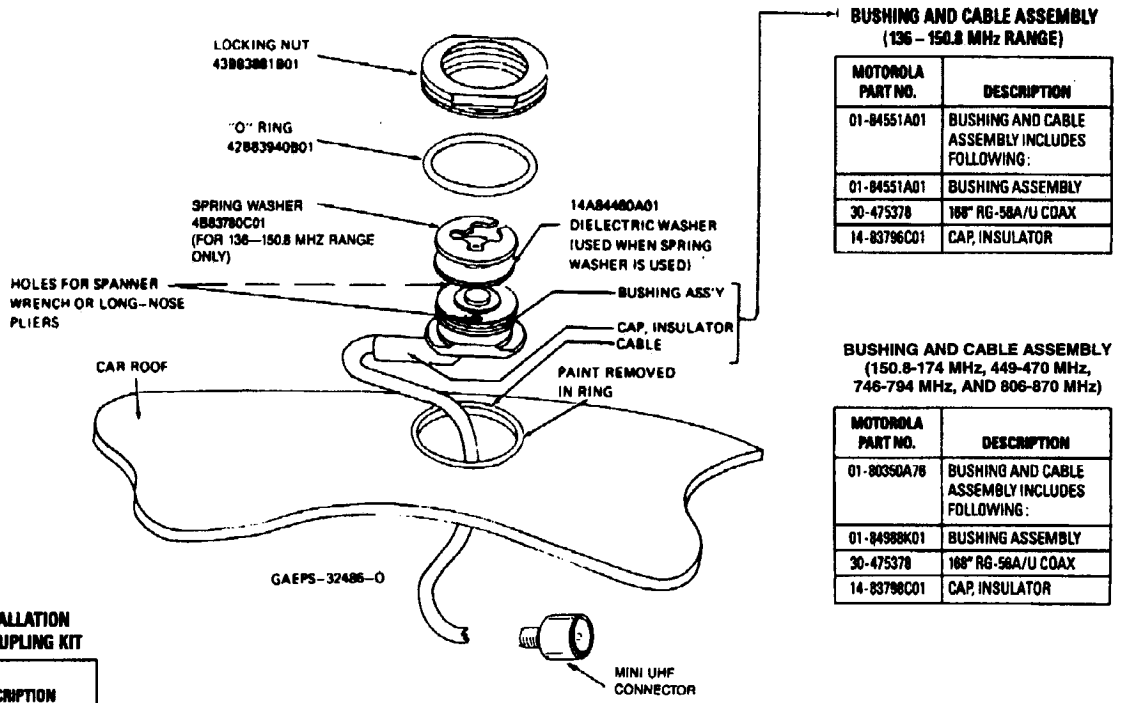

Figure 3. Roof Mount Parts Identification

REPLACEMENT INSTALLATION HARDWARE KIT W/O COUPLING KIT

MOTOROLA PART NO.	DESCRIPTION
11-80389B40	SILICONE GREASE
28-84606M01	MINI UHF CONNECTOR
42-83940B01	"O" RING
43-83881B01	LOCKING NUT

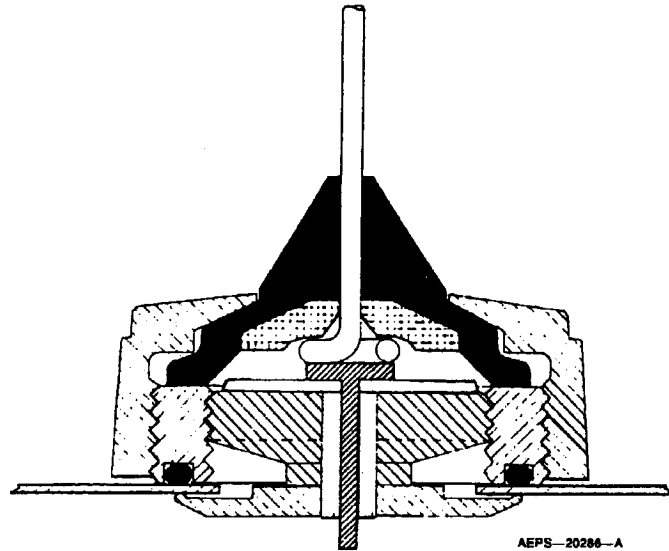

Figure 4. Cross-Section of Assembled Antenna

Installation

Mounting Hardware Installation – Roof Mount

General

The installation procedure which follows is for a typical passenger car. The procedure may vary slightly with the type of vehicle on which the antenna is to be installed. Generally speaking, however, the procedures outlined are of a universal nature.

NOTE

The antenna should be mounted on a flat metal roof of .020 to .040 inch thickness.

1. First, select a location for the antenna as near the center of the roof as possible.
2. The headlining may be probed with the fingers to make sure that all points of obstruction are avoided.

Installation Procedure Single Wall Construction

1. Locate the center of the roof by careful measurement, remove the headlining as necessary, and drill a pilot hole down through the roof. If the interior light of the car is centered in the roof, remove this light and fixture and drill the pilot hole up through the roof at about the center of the interior light mountings. This centers the antenna mount on the roof and allows for easy access.
2. Drill a 3/4-inch hole from the top of the roof until the saw bottoms. Use a Motorola hole cutting saw (01-80382A25) or equivalent. When the saw bottoms on the roof, it cleans off the paint in a neat circle and assures good contact with the locking nut.

IMPORTANT

For proper seating of brushing assembly, remove burrs and scrape any foreign matter from underside of hole out to at least 1/8-inch from edge.

3. Determine the routing of the cable from the antenna mounting base to the radio set; then remove the molding and trim necessary to facilitate pulling the cable through.

NOTE

To ensure ease of assembly, thread the locking nut on and then off the bushing assembly before installation. This removes any burrs which may be present.

4. Refer to Figure 5. From the top, feed the RG-58A/U lead-in cable between the headlining and the metal roof. Then route the cable between the roof and the radio set.
5. Refer to Figure 6. The bushing assembly is now in a position to drop into the hole in the roof. It should be tilted at a slight angle and fed into the 3/4-inch hold. The threaded top will not fall through the hole.
6. Refer to Figure 7. Hold the antenna bushing assembly in place with the index finger and thread the locking nut onto it as shown.
7. Pull up on the bushing assembly as illustrated in Figure 8, and make sure it is centered and seated (both shoulders inside the drilled hole), and that the "O" ring is in the groove in the locking nut. (As furnished, the "O" ring has been placed in the locking nut groove and imbedded in silicone grease.) Use a 15/16-inch open-end wrench to tighten the locking nut until it bottoms firmly against the roof top.

IMPORTANT

Refer to Figure 3. If the bushing assembly should slip or rotate for any reason during the tightening procedure, insert the tips of a long nose plier or spanner wrench into the two holes in the bushing assembly and apply force to prevent rotation until the locking nut is tight.

The locking nut *must* come into contact with the car roof to insure the proper antenna radiation pattern. This can only happen when the rubber "O" ring is fully compressed.

8. Take up the slack in the cable and replace the headlining retainer molding.
9. Replace headlining and dome light if removed.

Installation Procedure - Double Wall Construction

Vehicles With Dome Lights or Removable Headlining

1. Remove the dome light from its mount or remove the headlining from the installation area.
2. Drill a small pilot hole centered in the roof of the vehicle. The center of the cavity where the dome light was removed is sufficiently close.
3. Using a 1-1/4-inch diameter hole saw cut a hole in the inside layer of the metal.

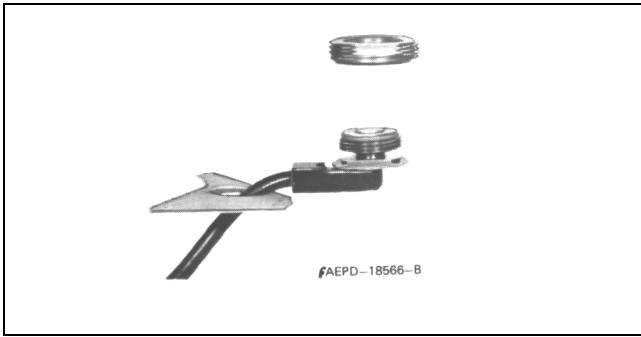

Figure 5. Coaxial Cable Insertion

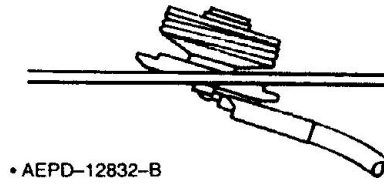

Figure 6. Bushing Assembly Insertion

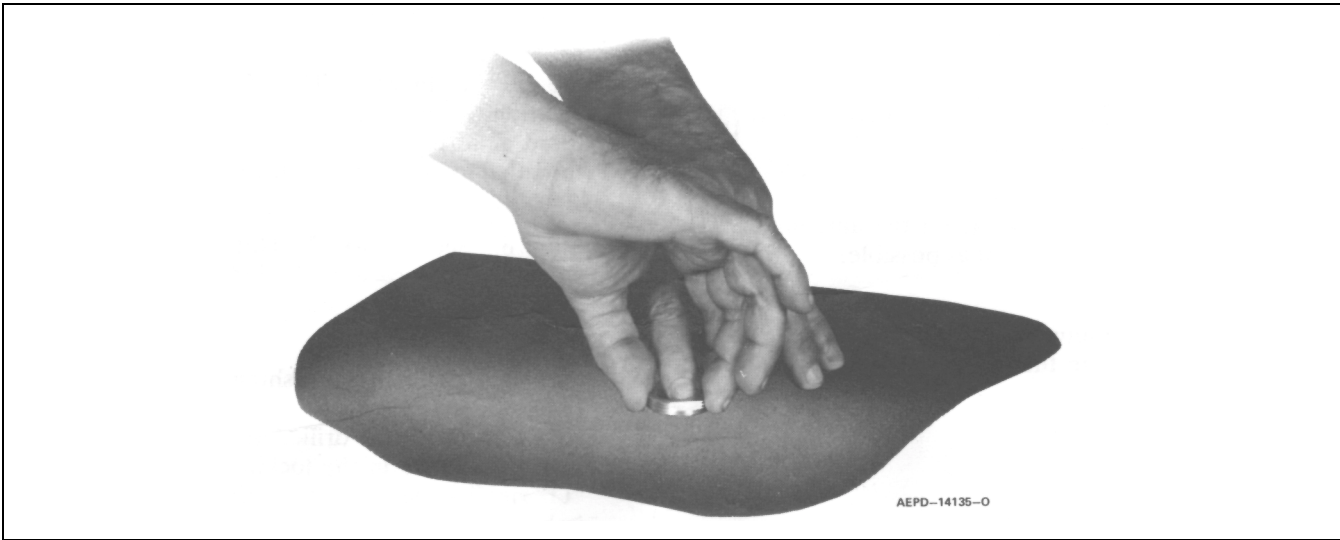

Figure 7. Locking Nut Positioning

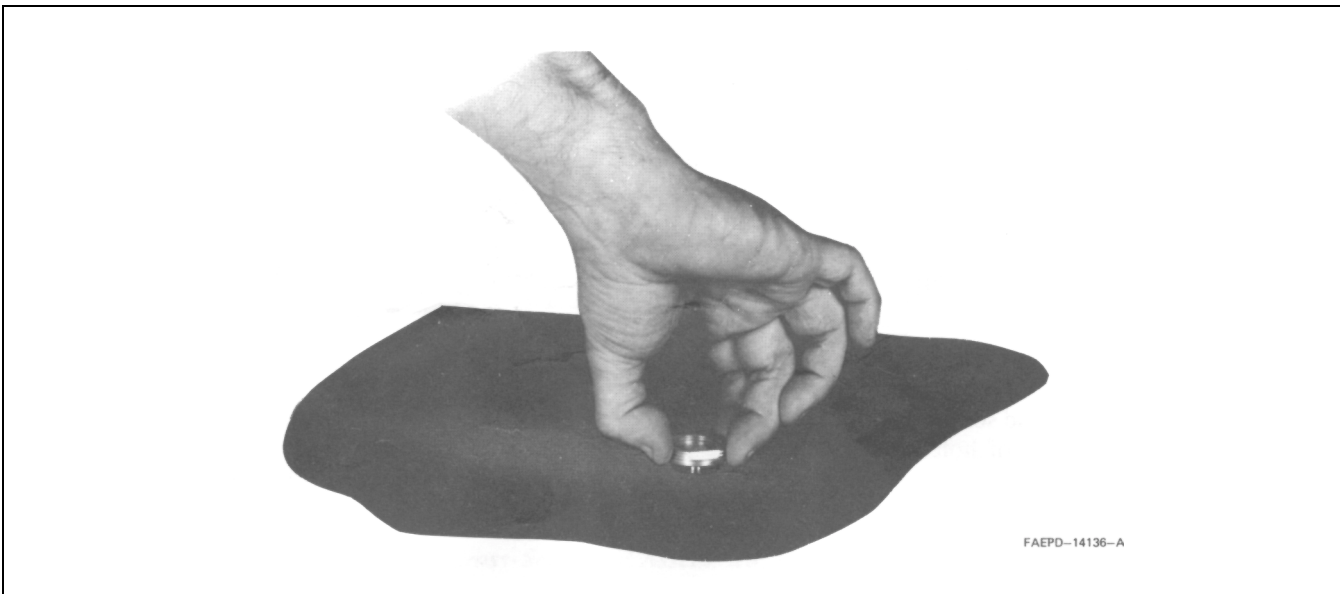

Figure 8. Locking Nut Tightening

4. Remove the metal and filler from this 1-1/4-inch diameter hole.
5. Complete the installation per installation procedure given for vehicles with single wall construction. A completed mount is illustrated in Figure 9.

Vehicles Without Dome Lights

When the vehicle has no dome light, and it is not feasible to remove the headlining to get to the inside surface, proceed as follows:

1. Locate the center of the roof and make sure the area beneath this point is clear to allow passage of a drill.
2. With a 3/4-inch diameter hole cutting saw carefully cut a 3/4-inch hole from the top of the roof through both thicknesses of metal. Clean the metal in a neat circle around the hole to assure a good contact between the roof metal and the locking nut.
3. Remove any burrs and remove the filler separating the roof thickness for a distance of 1/4-inch back from the hole.

4. Install the mount to the outside roof thickness per installation procedure given for vehicles with single wall construction.

Mounting Hardware Installation – Trunk Lip Mount

NOTE

Not recommended for transmitters with power outputs of 7 W or greater.

1. Refer to Figure 11 for antenna location.
2. Using the Allen wrench supplied, turn the two set screws counterclockwise until their threads are not visible on the underside of the clamp bracket.
3. Raise the trunk lid to pass the coaxial cable through; then tilt the mounting base slightly to hook the clamp bracket on the trunk lip. The coaxial cable, coming from under the mounting base, may have to be bent down to accomplish this step. When the base is in position, the coaxial cable should not bind in any way, or be pinched under a set screw.
4. Tighten the two set screws.

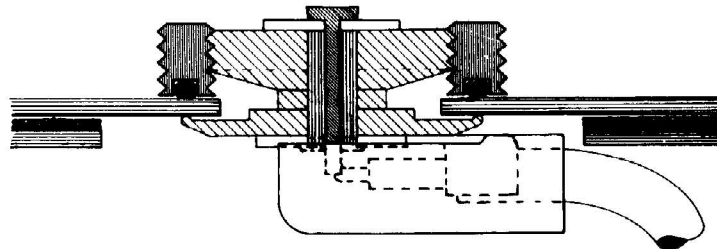

GAEPS-8707-C

Figure 9. Roof Mount in Vehicle With Dome Light or Removable Headlining

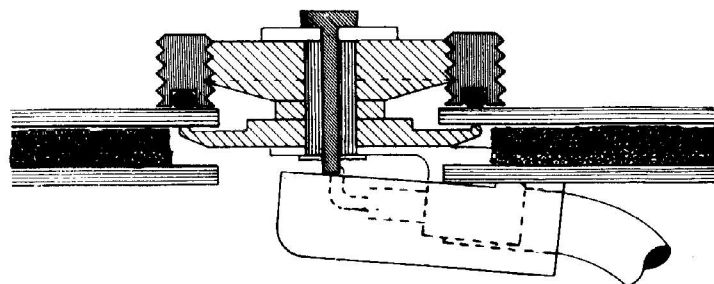

GAEPS-8708-D

Figure 10. Roof Mount in Vehicle Without Dome Light

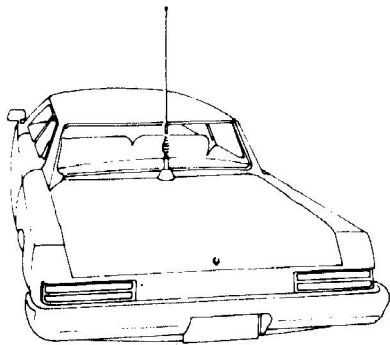

GAEPS-13094-0

Figure 11. Typical Mount Location

NOTE

The coaxial cable will normally not be harmed by opening and closing the trunk, although reasonable care should be exercised. The rubber molding around the trunk lid will prevent damage to the cable.

5. Route the cable from the mounting base to the radio set. Rubber grommets should be used in any sheet metal holes through which the cable is routed. Ensure that the cable will not be pinched during normal vehicle operation.

Mini-UHF Connector Installation

Use Motorola hand tool part #66-80388A26 (Refer to Figure 12). A deluxe ratchet type tool is available; order part #66-80334B40.

Installation Instructions

1. Slip ferrule and collar onto cable. Refer to Figure 13.
2. Prepare cable to strip dimensions per Figure 14, which is also marked on the hand tool.
3. Insert stripped cable into plug body until conductor is exposed (front end) and dielectric bottoms inside body. Refer to Figure 13.

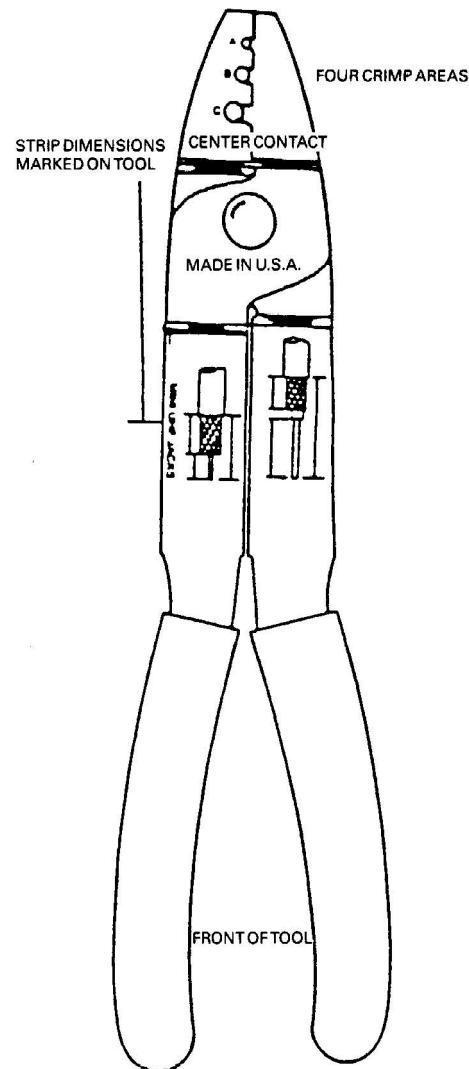

Figure 12.

4. Crimp center contact using proper crimp section of tool. Refer to Figure 12 marked "CENTER CONTACT."
5. Push collar forward onto plug assembly. Fit cable braid over the support sleeve of the connector. Refer to Figure 13.
6. Push ferrule over braid until flange butts against connector body. Refer to Figure 13. Using the correct crimp area of the tool, crimp the ferrule close to the plug body. See Figure 12, crimp location "C." Crimp ferrule a second time close to the cable end.
7. The protruding center conductor should be trimmed flush with the end of the center contact.

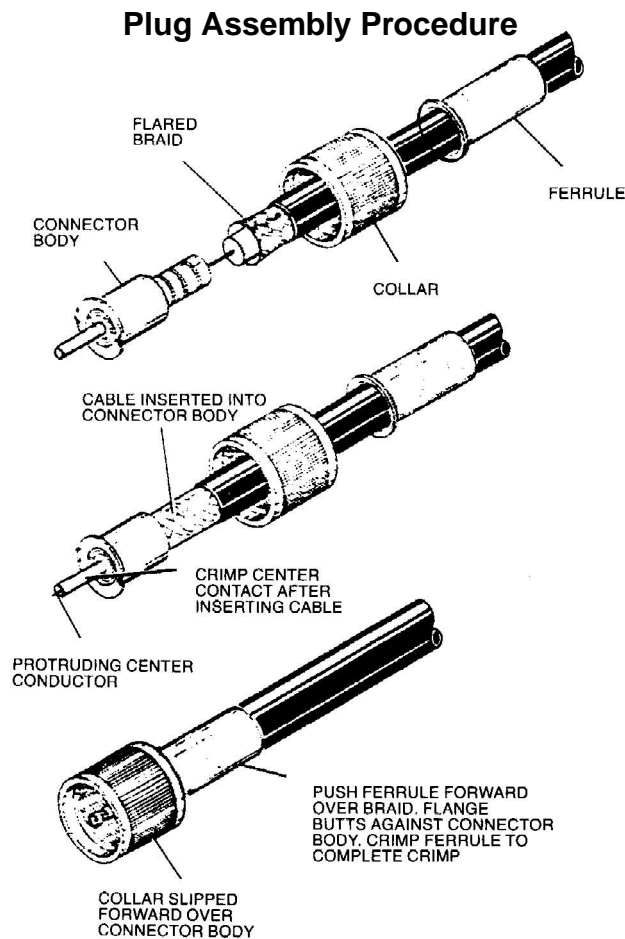

Figure 13. Plug Assembly Procedure

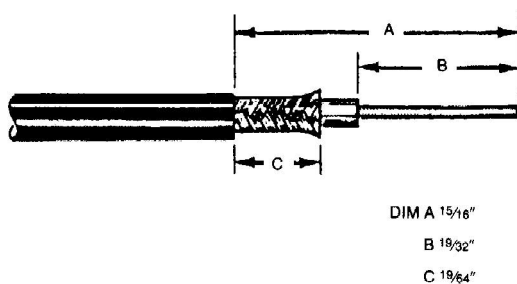

Figure 14.

Frequency Conversion

See Table 1. Antennas in each band are equipped with whip radiators cut to the proper length for that specific band. To change from one band to another, a whip assembly of the proper length should be substituted for one previously in use. Antennas in the 136-150.8 MHz range are also equipped with a spring washer

(roof mount models only; see Figure 3) to provide for proper impedance matching. Should it be desired to change from an antenna in the 136-150.8 MHz range to one in the other ranges, this washer must be removed in addition to changing the whip assembly. Conversely, to shift from the other ranges to the 136-150.8 MHz range, a spring washer must be installed in addition to changing the whip assembly.

Motorola Recommendations for Mobile Antenna Location

Recommended mobile antenna installations are limited to metal body vehicles at the center of the roof and center of the trunk deck locations. Refer to Table 2.

The antenna installation must additionally be in accordance with:

- the requirements of the antenna manufacturer/supplier
- instructions in the Radio Installation manual.

Antenna Location

Mobile Antenna Installation

Mobile Radio Operation and EME Exposure

Observe the following caution and electromagnetic energy exposure (EME) statements when installing antennas:

CAUTION

Use caution when installing antennas with mobile radio equipment using transmitter power of 7 W or greater. Install antennas only on metal bodied vehicles.

NOTE

For low-power mobile radios (less than 7 W) there are no antenna type or installation restrictions.

To assure optimal radio performance and that human exposure to radio frequency electromagnetic energy is within the guidelines referenced in this document, transmit **only** when people inside and outside the vehicle are at least the minimum distance away from a properly installed, externally-mounted antenna.

Table 3 lists the minimum distance for several different ranges of rated radio power.

Selecting an Antenna Site

1. Install the vehicle antenna **external** to the vehicle and in accordance with the requirements contained in this manual.

2. The best mounting location for the antenna is in the center of a large, flat conductive surface. In almost all vehicles, mounting the antenna in the center of the roof will satisfy these requirements. A good alternative location is in the center of the trunk lid. If you use the trunk lid, ensure that the trunk lid is grounded by connecting grounding straps between the trunk lid and the vehicle chassis.
3. Ensure the antenna cable can be easily routed to the radio. Ensure that the antenna cable is routed separately and not in parallel to any other vehicle wiring or mobile radio cable wiring.
4. Check the antenna location for any electrical interference.

NOTE

Any two metal pieces rubbing against each other (such as seat springs, shift levers, trunk and hood lids, exhaust pipes, etc.) in close proximity to the antenna can cause severe receiver interference.

5. If the vehicle is equipped with an electronic anti-lock braking system (ABS), mount the antenna at the center of the roof or trunk lid and do not route the antenna cable near the ABS Modulator Box. Mount the radio as far away from the Modulator Box as physically possible. This minimizes radio interference to the modulator box from the radio.
6. Make sure the mobile radio antenna is installed at least one foot (30.48cm) away from any other antenna on the vehicle.

Table 2.

Standard metal passenger vehicles	Center roof or center trunk lid
Vans, pickups, and other light trucks (metal roofs)	Center roof
Heavy duty equipment with metal roofs (heavy duty trucks, semi-tractors, heavy refuse trucks, cement mixer trucks)	Center cab roof
Specialty vehicles (such as T-roofs, sun roofs, or convertibles)	Center trunk lid – recommended only for transmitter output of less than 7 W.
Other vehicles	Contact your Motorola Field Technical Representative. Do not install closer than the distances shown in Table 3, for the relevant transmitter output power, from occupants or without proper antenna ground plane.

Table 3. Rated Power and Distance

Rated Power of Vehicle-installed Mobile Two-Way Radios	Minimum Distance from Transmitting Antenna
7 to 15 W	1 Foot (30.5cm)
16 to 50 W	2 Feet (61cm)
More than 50 W	3 Feet (91.5cm)