

Boost Mobile[®]

i776 iDEN Handset

User's Guide

DECLARATION OF CONFORMITY

Per FCC CFR 47 Part 2 Section 2.1077(a)



Responsible Party Name: Motorola, Inc.

Address: 8000 West Sunrise Boulevard
Plantation, FL 33322 USA
Phone Number: 1 (800) 453-0920

Hereby declares that the product:

Product Name: i776

Model Number: H02XAH6JR6AN

Conforms to the following regulations:

FCC Part 15, subpart B, section
15.107(a), 15.107(d) and section
15.109(a)

Class B Digital Device

As a personal computer peripheral, this device complies with Part 15 of the FCC Rules. Operation is subject to the following two conditions: (1) this device may not cause harmful interference, and (2) this device must accept any

interference received, including interference that may cause undesired operation.

Note: This equipment has been tested and found to comply with the limits for a Class B digital device, pursuant to part 15 of the FCC Rules. These limits are designed to provide reasonable protection against harmful interference in a residential installation. This equipment generates, uses and can radiate radio frequency energy and, if not installed and used in accordance with the instructions, may cause harmful interference to radio communications. However, there is no guarantee that interference will not occur in a particular installation.

If this equipment does cause harmful interference to radio or television reception, which can be determined by turning the equipment off and on, the user is encouraged to try to correct the interference by one or more of the following measures:

- Reorient or relocate the receiving antenna.
- Increase the separation between the equipment and receiver.
- Connect the equipment into an outlet on a circuit different from that to which the receiver is connected.
- Consult the dealer or an experienced radio/TV technician for help.

Getting Started

Introduction

Welcome to Boost Mobile®

With Boost Mobile you pay up front, stay in control of your monthly costs, and get all the mobile freedom you want. No long-term contracts, no bills, no credit checks. This phone has the latest features including Nationwide Boost™ Walkie-Talkie, Wireless Web, Instant Messaging, Text and Multi-Media Messaging and GPS technology.

Make your phone all your own

Boost Mobile® offers the best in wireless entertainment services such as Boost™ Call Tones, Instant Messaging, and Boost™ Loopt as well as the latest games, applications, real music ringtones, wallpapers and more.*

Two easy ways to purchase content and get information on the latest services:

- From your handset: **boostLIVE** from the Main Menu
- On the web: Check out boostmobile.com

Purchases are deducted from your Boost Mobile account. No credit card needed.

Re-Boost®

You can recharge your account directly from your handset using the **Re-Boost** menu option. On your phone, launch the service from the Main Menu. You will then be able to log on and recharge

* Network dependent feature, not available in all areas. Airtime, data charges, and/or additional charges may apply.

your account using your credit card or Re-Boost® Card. You can also view your account balance and call credit expiration date. The account pass code is the same one that you use to access your account.

Instant Re-Boost®

You can recharge instantly by dialing the letters ADD (233) from your mobile phone and press Send. You are not required to enter your personal telephone number (PTN) or passcode.

If you select Prepaid Card, you will be asked to enter the 14-digit card number printed on the Re-Boost® Card. If you've selected credit card, you will be asked simply to confirm your purchase. You will need to have a credit card already on file to use it for purchasing airtime. Call 1-888-BOOST-4U to have your credit card added to your account.

Boost Customer Care

1-888-BOOST-4U (1-888-266-7848) or dial 611 from your i776 phone.

Important: Before using your phone please read the "Terms and Conditions of Service", "Driving Tips" and "Safety and General Information".

Check it out

Introducing your Motorola i776 wireless phone. Here is a quick anatomy lesson.

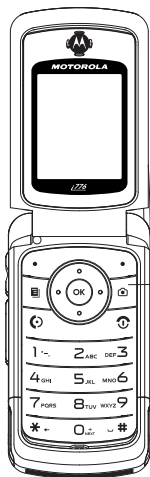

Camera Key

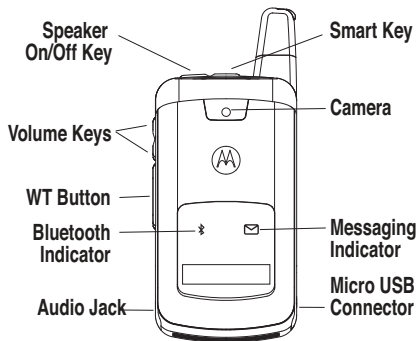

Speaker
On/Off Key

Smart Key

Camera

Volume Keys

WT Button

Bluetooth
Indicator

Messaging
Indicator

Audio Jack

Micro USB
Connector

Home Screen

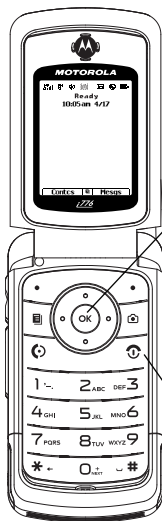



② Customizable  key that can be used to open the **Settings** screen

① Press and hold the **Power Key**  for a few seconds, or until the screen lights up, to turn on your phone.

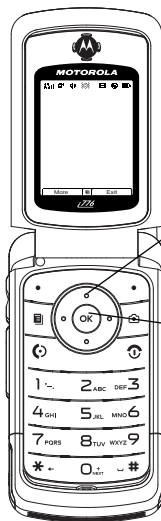
Main Menu



③ Press the Navigation Key **up, down, left or right** () to highlight a menu feature.

④ Press the  key to select.

Motorola, Inc.
Consumer Advocacy Office
1307 East Algonquin Road
Schaumburg, IL 60196

www.hellomoto.com

1-800-331-6456 (United States)
1-888-390-6456 (TTY/TDD United States for hearing
impaired)
1-800-461-4575 (Canada)

Product Support:

www.motorola.com/iden

Certain mobile phone features are dependent on the capabilities and settings of your service provider's network. Additionally, certain features may not be activated by your service provider, and/or the provider's network settings may limit the feature's functionality. Always contact your service provider about feature availability and functionality. All features, functionality, and other product specifications, as well as the information contained in this user's guide are based upon the latest available information and are believed to be accurate at the time of printing. Motorola reserves the right to change or modify any information or specifications without notice or obligation.

This device supports Bluetooth 1.2 and HS/HF/OPP/DUN/BPP profiles. In order for Bluetooth devices to communicate with one another, they must utilize the same Bluetooth profile. To determine the profiles supported by other Motorola devices, visit www.hellomoto.com/bluetooth. For other devices, contact their respective manufacturer.

Certain Bluetooth features including those listed may not be supported by all compatible Bluetooth-enabled devices, and/or the functionality of such features may be limited in certain devices, or by certain wireless carriers. Contact your wireless carrier about feature availability and functionality.

Caution: Changes or modifications made in the radio phone, not expressly approved by Motorola, will void the user's authority to operate the equipment.

MOTOROLA and the Stylized M Logo are registered in the US Patent & Trademark Office. All other product or service names are the property of their respective owners. Java and all other Java-based marks are trademarks or registered trademarks of Sun Microsystems, Inc. in the U.S. and other countries.

© Motorola, Inc., 2008.

Manual Number: NNTN7463A

Contents

Getting Started	1	Call a stored phone number or		Boost Mobile®	
Introduction	1	Walkie-Talkie ID	22	Services	65
Re-Boost®	1	Your phone number and Walkie-Talkie ID	23	Accessories	65
Instant Re-Boost®	2	Text messages.	23	Wireless local number portability:	
Boost Customer Care	2			Bringing your phone number from another carrier	65
Check it out	3	Main Attractions	29	Boost Customer Care	65
Menu Map	8	Media center.	29	Customize	67
Use and Care	11	Camera	30	Ringtones.	67
Essentials	13	boostLIVE	32	Wallpaper	68
About this guide.	13	WT Features	32	Backlight	69
SIM chip	14	One touch WT	37	LED indicators.	69
Battery.	15	WT service.	38	Datebook	69
Turn it on & off	19	MMS	38	Hide or show location information.	70
Enable security	20	Bluetooth®	54	Calls	71
Make a call.	20	Basics	59	Recent calls	71
Answer a call	20	Display	59	Redial	72
Make a Walkie-Talkie call	21	Text entry	60	Voice names	72
Answer a Walkie-Talkie call	21	Volume	62	Caller ID	72
Store a phone number or Walkie-Talkie ID.	21	Navigation key	63	Call forward.	73
		Handsfree speaker.	63	Emergency calls.	73
		Lock & unlock phone	63		
		Airplane Mode	64		

International calls . . .	74	Smart Practices	
Speed dial	74	While Driving	104
Turbo dial	75	Index	106
Voice mail	75		
Other features	77		
Advanced calling . . .	77		
Contacts	78		
Datebook	78		
GPS	79		
Handsfree	81		
Personalize	82		
PC applications	82		
TTY	83		
Security	84		
Safety and General			
Information	86		
Motorola Limited			
Warranty for the			
United States			
and Canada	93		
Hearing Aid			
Compatibility	98		
Information From the			
World Health			
Organization	100		
California Perchlorate			
Label	102		
Privacy and Data			
Security	103		

Menu Map

Main Menu



Re-Boost

WT Service

- Send Picture
- Send Event
- Send My Info
- Send Contact
- Configure



Web



Games & Apps.



Ringtones

- Buy Ringtones
- Vibrate All: On/Off
- Ringers
- Vibrate
- Silent



Recent Calls



Settings

- (see next page)



My Info

- My Name
- Line 1
- Walkie-Talkie #
- Group ID
- Carrier IP
- IP1 Address
- IP2 Address
- Circuit Data



Datebook



Contacts



Messages

- [Create Message]
- Voice Mail
- Inbox
- Drafts
- Sent Items
- Net Alert
- SMS



Voice Notes

- [New VoiceRec]
- Surveillance



Profiles

- [New Profile]
- Standard
- Car
- At Work/In Class
- At Concert
- On a Date
- Using Headset
- Rec WT Only
- Rec Cntcs Only



boostLIVE



Memo



Shortcuts

- [New Entry]
- Shortcuts
- Cntcs[New Contact]
- Recent Calls
- Contacts
- Re-Boost
- Messages
- VoiceRecord
- Web
- Ringtones



Call Timers

- Last Call
- Phone Reset
- Phone Lifetime
- WT Reset
- WT Lifetime
- Circuit Reset
- Circuit Lifetime
- Kbytes Reset



GPS

- Position
- Privacy
- Interface



Call Alert



Call Forward

- Forward
- To: On/Off



Camera



Media Center



Bluetooth

- Hands Free
- Link to Devices
- Device History
- Setup
- Find Me

This is the standard Main Menu layout. Your phone's menu may be a little different.

Settings Menu

Display/Info

- Wallpaper
- Text Size
- Theme
- Home Icons
- Backlight
 - Backlight
 - Java Timer
 - Logo Flash: On/Off
 - WT Backlight: On/Off
- Clock
- Menu View
- Large Dialing
- Contrast
- Language

Phone Calls

- Any Key Ans
- Auto Redial
- Call Waiting
- Auto Ans
- Minute Beep
- Call Duration
- TTY
- Notifications
- DTMF Dialing
- Prepend

WT Options

- Tkgpr Silent: On/Off
- Tkgpr Area
- One Touch WT
- Alert Type
- On/Off WT Features
 - Pictures
 - Events
- Store Received Info
- WT Backlight: On/Off

Personalize

- Menu Options
- Up Key
- Down Key
- Left Key
- Right Key
- Center Key
- Left Softkey
- Right Softkey
- Power Up

Volume

- Line 1
- Messages
- Earpiece
- Speaker
- Keypad
- Java Earpiece
- Java Speaker
- Data

Security

- Phone Lock
- Keypad Lock
- SIM PIN
- GPS PIN
- Change Passwords

Advanced

- Alert Timeout
- Headset/Spkr
- Connectivity
- Reset Defaults
- Return to Home
- Transmitters: On/Off
- Baud Rate

Use and Care

To care for your Motorola phone, please keep it away from:



liquids of any kind

Don't expose your phone to water, rain, extreme humidity, sweat, or other moisture.



dust and dirt

Don't expose your phone to dust, dirt, sand, food, or other inappropriate materials.



extreme heat or cold

Avoid temperatures below -10°C/14°F or above 45°C/113°F.



cleaning solutions

To clean your phone, use only a dry soft cloth. Don't use alcohol or other cleaning solutions.



microwaves

Don't try to dry your phone in a microwave oven.



the ground

Don't drop your phone.

Essentials

CAUTION: Before using the phone for the first time, read the *Important Safety and Legal Information* included in the gray-edged pages at the back of this guide.



About this guide

This guide shows how to locate a menu feature as follows:

Find it:  > 

This means that, from the home screen:

- 1 Press the *menu button*  to open the **Main Menu**.

- 2 Press the *navigation key*  to scroll to , and press the *center key*  to select it.

symbols



This means a feature is network/subscription dependent and may not be available in all areas. Contact your service provider for more information.



This means a feature requires an optional accessory.

SIM chip

Your Subscriber Identity Module (SIM) chip can be found attached to a piece of plastic about the size of a credit card inside the “Starter Kit” that came with your phone. Your SIM chip contains personal information like your phone number and phonebook entries.

To activate your phone, you will need the SIM ID and the Activation Number located on the back of the plastic.

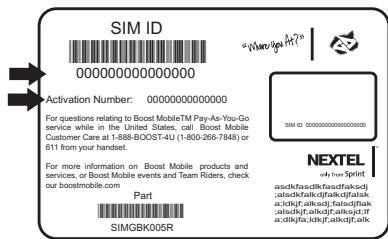

Pop out the SIM chip from the plastic card and insert it into the back of your phone as described next.

Caution: Don't bend or scratch your SIM chip. Keep it away from static electricity, water, and dirt.

Installing the SIM chip

Turn off your phone and remove your battery before you install or remove a SIM chip.

- 1 Carefully slide the SIM chip into your phone, until it lies flat in the SIM chip holder.

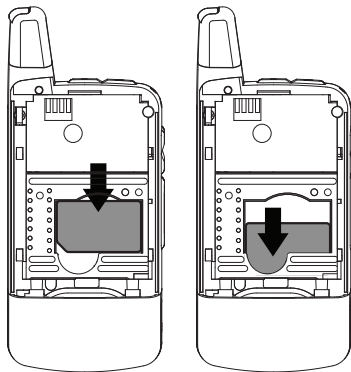

Removing the SIM Chip

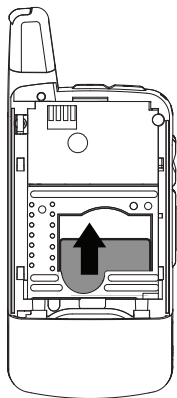

Warning: To avoid loss or damage, do not remove your SIM chip from your phone unless absolutely necessary.

Battery

Battery Use & Battery Safety

- Motorola recommends you always use Motorola-branded batteries and chargers. The warranty does not cover damage caused by non-Motorola batteries and/or chargers. Caution: Use of an unqualified battery or charger may present a risk of fire, explosion, leakage, or other hazard. Improper battery use, or use of a damaged battery, may result in a fire, explosion, or other hazard.
- Battery usage by children should be supervised.
- **Important:** Motorola mobile devices are designed to work best with qualified batteries. If you see a message on your display such as **Invalid Battery**

or **Unable to Charge**, take the following steps:

- Remove the battery and inspect it to confirm that it bears a Motorola “Original Equipment” hologram;
- If there is no hologram, the battery is not a qualified battery;
- If there is a hologram, replace the battery and retry charging it;
- If the message remains, contact a Motorola Authorized Service Center.
- New batteries or batteries stored for a long time may take more time to charge.
- Charging precautions: When charging your battery, keep it near room temperature. Never expose batteries to temperatures below 0°C (32°F) or above 45°C (113°F) when charging. Always take your mobile device with you when you leave your vehicle
- When storing your battery, keep it in a cool, dry place.
- It is normal over time for battery life to decrease, and for the battery to exhibit shorter runtime between charges or require more frequent or longer charging times.
- Avoid damage to battery and mobile device. Do not disassemble, open, crush, bend, deform, puncture, shred, or submerge the battery or mobile device. Avoid dropping the battery or mobile device, especially on a hard surface. If your battery or mobile device has been subjected to such damage, take it to a Motorola Authorized Service Center before using. Do not attempt to dry it with an

appliance or heat source, such as a hair dryer or microwave oven.

- **Use care when handling a charged battery**—particularly when placing it inside a pocket, purse, or other container with metal objects. Contact with metal objects (e.g., jewelry, keys, beaded chains) could complete an electrical circuit (short circuit), causing the battery to become very hot, which could cause damage or injury.

Promptly dispose of used batteries in accordance with local regulations. Contact your local recycling center for proper battery disposal.



Warning: Never dispose of batteries in a fire because they may explode.

Battery installation

- 1 Slide the battery door up until it is released.

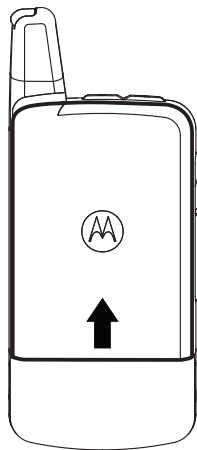

- 2 Remove battery door.

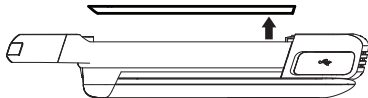

- 3 Insert battery as shown below. Push the battery down until it snaps in place.

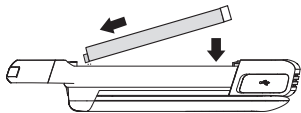

- 4 Replace the battery door.

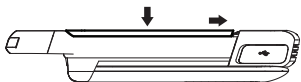

Battery charging

New batteries are not fully charged. Plug the battery charger into your phone and an electrical outlet. Your phone might take several seconds to start charging the battery.

To charge using the charger:

- 1 Pull out the connector cover, and insert the charger into the micro-USB connector on your phone as shown

- 2 Plug the other end of the charger into the appropriate electrical outlet.

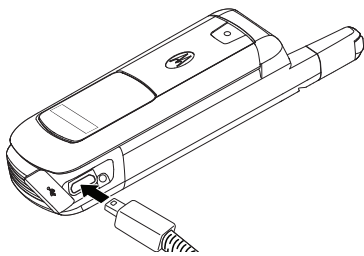

- 3 When your phone displays **Charge Complete**, remove the charger.

When you charge the battery, the battery level indicator at the upper right of the screen shows charging progress. At least one segment of the indicator must be visible to ensure full phone functionality while charging.

Tip: Motorola batteries have circuitry that protects the battery from damage from overcharging. Of course, unplugging the charger from the wall will avoid current drain.

To charge from your computer



You can partially charge your phone's battery by connecting a Motorola-approved USB cable from your phone's micro-USB port to a high-power USB connector on a computer (not a low-power one, such as the USB connector on your keyboard or bus-powered USB hub). Typically, USB high-power connectors are located directly on your computer.

Your computer must be turned on, and you must have correct software drivers installed on your computer. If the Phone is off when the USB cable is connected between the computer and the phone, the phone will power up in charging mode. This mode allows the phone to charge fastest and quickest.

Note: If the battery is very low, the phone will not turn On, but it will continue to charge at a low rate. The phone will power up in charging mode

when the battery has been charged to approximately 5% of its capacity.

If the phone is turned on while charging from a computer, it will not fully charge the battery. In this case, the battery charge will be maintained approximately between 80% and 95% of the battery's capacity. Cables and software drivers are available in Motorola Original™ data kits, sold separately.

Turn it on & off

To turn on your phone, press and hold  for a

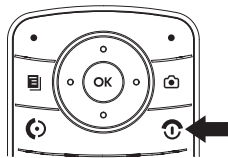



few seconds or until the display turns on.

To turn off your phone, press and hold  for two seconds.

Note: If you press  for more than four seconds, the handset will power “On” on “Transmitter Off” mode. See “Airplane Mode” on page 63.

Enable security

You must enable security the first time you power on your phone or within 10 days of first activation.

- 1 Press  under **Ok**.
- 2 You are prompted to enable security. Press  under **Yes**. A series of screens followed by the default home page displays.
- 3 Press  to return to the home screen.

Make a call





Enter a phone number and press  to make a call or use a voice name. See “Voice names” on page 72.

Note: For best call quality avoid covering the antenna with your hand.

To hang up press .

Answer a call

When your phone rings and/or vibrates, you have the following options to answer:

- 1 If you want to answer the call on the handsfree speaker phone, press the speaker key  with the flip closed. To hang up press the smart key .
- 2 If you want to answer the call using the handset, just open the flip and press . To hang up press  or close the flip.

Note: You must have the **Flip Activation** feature On. See “Advanced calling” on page 77.

Make a Walkie-Talkie call

With Walkie-Talkie calls service, you use your phone as a long-range, digital 2-way radio using one-to-one Walkie-Talkie calls.

Your Walkie-Talkie ID is the number at which you receive one-to-one Walkie-Talkie calls.

To Make a Walkie-Talkie Call

- 1 Enter the Walkie-Talkie ID you want to call.
- 2 Press and hold the WT button. Begin talking after your phone emits a chirping sound.
- 3 Release the WT button to listen.

To end the call press .

Note: A Walkie-Talkie ends automatically if there is no activity on the call for a few seconds.

Tip: To let someone know you want to talk to them on a Walkie-Talkie, press  under **Alert**.

Answer a Walkie-Talkie call

- 1 When your phone emits a chirping sound or vibrates to indicate you are receiving a Walkie-Talkie call, wait for the caller to finish speaking.
- 2 Press and hold the WT button and begin talking after your phone emits a chirping sound.
- 3 Release the WT button to listen.
To end the call press  under **Exit**.

Store a phone number or Walkie-Talkie ID

You can store a phone number or Walkie-Talkie ID in **Contacts**:

- 1 Press  >  > **[New Contact]**.

- 2 Enter a name for the new entry. Each entry's name can contain up to 20 characters.
- 3 Select **Ringer** if you wish to assign a specific ring tone to that phone number.
- 4 Select a type for the entry (**Mobile, Walkie-Talkie, Work1, Work2, Home, Email, Fax, Pager, IP** or **Other**). To store a Walkie-Talkie ID, choose **Walkie-Talkie**.
- 5 Enter the number for the entry and press  under **Done** to save the entry.

Tip: Before saving the entry, you can save more information. You can store E-mail addresses or IP addresses. You can assign each number a speed dial number and voice name.

After you have saved the number, the new Contacts entry is displayed.

Call a stored phone number or Walkie-Talkie ID

Shortcut: From the home screen press

 under **Contacts**

or

Find it:  > 

- 1 Scroll to the **Contacts** entry.
Tip: By pressing the first letter of the name of the **Contacts** you want, you will be taken to all the contact names starting with the letter you pressed.
- 2 If the Contacts entry contains more than one number, scroll left or right until the type of the number you want to call is displayed (**Mobile, Walkie-Talkie, Work1, Work2, Home**, etc.).
- 3 If you choose a phone number, press  to call the entry.
or

If you choose a Walkie-Talkie ID, press and hold the WT button to call the number.

Tip: If the Contacts entry you scrolled to contains a Walkie-Talkie ID, you can make an instant Walkie-Talkie call to that Walkie-Talkie ID by pressing and holding the WT button, even if the Walkie-Talkie ID is not the type of number displayed.

Your phone number and Walkie-Talkie ID

Find it:  > **My Info**

Tip: Want to see your phone number or Walkie-Talkie ID while you're on a call? Press  > **My Info**.

Text messages





If your service provider offers text messaging, your phone sends text messages using Mobile Originated

Short Messaging Services (MOSMS) and receives text messages from other phones that are using MOSMS.

Note: The Message LED will be activated when you receive a new Message/vmail/NetMail/OAP alert. It will remain on until there are no unread items in Message Center or until it reaches the 30 minute timeout.

Set it up

Before you begin using text messaging, you may need to set up your signature, service center number, and expiration information.

Shortcut: From the home screen press  under **Msgs** >  >

Text Msg Setup.

or

Find it:  >  >  > **Text Msg Setup**



The following options become available:

option
Friendly Name: Enter your name (up to 20 characters long).
Signature: Enter your signature (up to 100 characters long).
Quick Notes: Quick Notes are short, pre-written text messages that you can create, edit, and send in your text messages. You can store up to 20 quick notes. A quick note may be up to 30 characters long. You can create a [New Quicknote] or press  under Edit to change the pre-written quick notes.

option
Replies: Replies are short, pre-written text messages that you can create, edit, and send in your text messages. You can store up to 20 quick notes. A quick note may be up to 30 characters long. You can create a [New Reply] or press  under Edit to change the customized pre-written reply.
Cleanup: Set this option to On if you want your phone to delete sent messages. If you set Cleanup to On , select Clean Up After to set the number of days after which sent messages are deleted or the number of messages to be kept.

Press  under **Done** to save the information you entered.

Receive a text message

- 1 To view the message press  under **Read**.
- 2 To dismiss the message notification press  under **Exit**.



Note: If your phone is powered off when you receive a text message, your phone notifies you the next time you power it on. If you are out of your coverage area, your phone alerts you when you return to your coverage area.

Tip: While reading a text and numeric message that contains a phone number, you can press  to call that number.

Read from the message center

- 1 From the home screen press  under **Msgs > Inbox > Text Inbox**.
- 2 Select the message you want to read or press the number of the message you want to read. If the message fills more than one screen, scroll to read it.

Tip: Scrolling through one message lets you view the next message.

- 3 To reply to the message, press  under **Reply** or to see all other choices, including forwarding and deleting the message, calling the sender, or storing the sender's number in **Contacts**, press .

Create and send text messages

- 1 From the home screen press  under **Msgs > [Create Message] > [Create Txt Msg]**.



or

Select **Inbox > Text Inbox**, or **Outbox > Text Outbox**, or **Drafts > Text Draft**.

- 2 To address the message use the keypad to enter the phone number of the person you want to send the message to and press .

or

Press  under **Contacs**, and select the number you want.

- 3 Select **Msg** and enter the text of the message or to use a quick note press  under **QNotes** and scroll to the quick note you want.
- 4 If you want to send the message, press  under **Send** or to delete the message without sending it, press  under **Cancel**.

Use drafts

When you save a message as a draft, it is saved in the drafts folder.

Shortcut: From the home screen press  under **Msgs > Drafts > Text Drafts**.

- 1 Select the draft you want to edit. You also have the choice to create new text messages from this menu.
- 2 To edit the fields you want to change, follow step 2 through step 5 in “create and send text messages” above.

Resend text messages

Shortcut: From the home screen press  under **Msgs > Outbox > Text Outbox**.



- 1 Scroll to the message you want to resend or press the number of the message you want to resend.
- 2 Press  under **Resend**.

Delete sent text messages

Shortcut: From the home screen press

 under **Msgs > Outbox >**

Text Outbox.

- 1 Scroll to the message you want to delete.
- 2 Press  under **Delete.**
- 3 Press  under **Yes** to confirm.

Delete all unlocked sent messages

Shortcut: From the home screen press

 under **Msgs > Outbox >**

Text Outbox.

- 1 Press  > **Delete All.**
- 2 Press  under **Yes** to confirm.

Go to a website

If a message contains one or more website URLs, you can go to that website. See “Go to a website” on page 48.

Manage Memory



Your text inbox, outbox, and drafts folder have a set amount of memory available for storing messages.

The text inbox holds 20 messages. If the text inbox is full, you cannot receive messages until you delete some.

The outbox and drafts folder share memory space. Together they can hold 30 messages. If the outbox and drafts folder memory is full, you cannot send messages or save drafts until you delete some.

To view the amount of memory available in your text inbox:

Shortcut: From the home screen press

 under **Msgs >  > Setup >**

Memory Size.

Main Attractions

Media center

The media center lets you access pictures and audio recordings stored in your phone's memory.

The following audio recordings can be accessed through the media center:

- Voice records
- Musical ring tones in the list of ring tones
- Audio recordings saved from MMS messages received
- Audio recordings downloaded to your phone

Items in the media center can be sent in messages and with Bluetooth. See "MMS" on page 38 and "Bluetooth®" on page 54.

Pictures in the media center can be sent in Walkie-Talkie calls using Send via WT. See "WT Features" on page 32.

Audio files supported by the Media Center include:

Format	Sampling Rates/Bit Rates
.au	8 KHz/8 kbps
.midi	8 KHz
.mp3	8 KHz/8 kbps
.wav	8 KHz/64 kbps

Image files supported by the Media Center include:

Format	Max. Image Size (in pixels)
.png	640 x 480
.gif	640 x 480

Format	Max. Image Size (in pixels)
.jpg	640 x 480
.bmp	127 x 127



Camera

The camera with a digital, external viewfinder in your handset takes pictures. You can save these pictures in your phone's memory. You can access these saved pictures through the media center.

You can send the pictures you take either in Walkie-Talkie calls or with Bluetooth. You can also set them as your phone's wallpaper.

Access the camera

There are many ways to access the camera. The simplest way is to press .

To take pictures aim the camera lens on the flip and press  under **Capture** or press .



To save the picture, press .

To discard the picture without saving it, press  under **Discard**.

From the camera viewfinder, you can press  to enter **Menu Options**.

The following options become available:



option
Media Center: Opens the Media Center application.
Lighting: Turn on the spotlight On before taking a picture in low light conditions. You can set it up to be Normal or Low Light .

option
Self Timer: Delay capturing the picture for a selected number of seconds. The values are: Off (default), 10 seconds , 15 seconds , and 20 seconds .
To turn off the timer before the picture is captured, press  under Cancel .
Picture Quality: Adjust the picture quality to Normal or Fine .
Picture Size: Set up the picture size to Xlarge (640x480) , Large (320x240) , Medium (160x120) , Small (128x96) , or Wallpaper (128x160) . You can also set picture size from the viewfinder by pressing  left and right.

Access the Media Center

You can access the media center from the camera at any time by pressing  > **Media Center**, except when you

are using the **Camera Setup** menu or viewing the memory screen.

The media center contains all your pictures, and music files located on your phone's memory. Use the  or the  to filter your results.

Customize the camera

Find it:  >  > **Camera Setup**

The following options become available:

option
Ask for Name: If this option is On , you are prompted to enter a name for each picture before saving. Otherwise, pictures are automatically saved with the date and a number as their names.
Default Size: Sets the default value for the Picture Size option.
Default Quality: Sets the default value for the quality of the picture.

boostLIVE

Your i776 comes with a main menu icon that takes you directly to **boostLIVE** web site .

You can download ringtones, wallpapers and Java applications over the air.

WT Features

Your phone can send and receive the following items through Walkie-Talkie calls with other phones that have this capability:



- Pictures*
- Datebook events
- My Info
- Contact information

You can choose to send My Info and contact information to any Walkie-Talkie ID.

*. Additional charges may apply.

You can choose to send pictures, messages, events to the Walkie-Talkie ID you are engaged in a a Walkie-Talkie call with, Walkie-Talkie IDs on the **Recent Calls** list, and Walkie-Talkie IDs stored in **Contacts**.

When you make or receive a Walkie-Talkie call, your phone automatically determines whether the phone you are engaged in a Walkie-Talkie call with is able to receive each of these items. Your phone saves this information for as long as the Walkie-Talkie ID is on your **Recent Calls** list or is saved in your **Contacts**. Your phone updates the saved information each time you make or receive a call to or from that Walkie-Talkie ID.

You can turn your phone's ability to send and receive messages, pictures, events on and off.

Send pictures



You can send pictures stored in **Media Center** through Walkie-Talkie calls. The picture you send appears on the Walkie-Talkie call recipient's display.

If the recipient accepts the picture, their phone saves the picture.

The first time you send a stored picture after turning the phone on, **Picture Fees May Apply. Continue?** appears and you are prompted to respond.

Note: You cannot make or receive Walkie-Talkie calls while transmitting or receiving a picture.

Send a picture during a call

- 1 While in a Walkie-Talkie call, press  under **Picture** or press  > **Use WT Feature > Send Picture.**

A list of pictures that can be included in a Walkie-Talkie call appears.

- 2 Select the picture you want to send.
- 3 Press the WT button to send the picture.
- 4 Wait while the picture is transmitted. The Walkie-Talkie call is temporarily interrupted while a picture is transmitted.
- 5 When prompted, press the WT button to resume the Walkie-Talkie call.

Start a call by sending a picture

From Media Center

Find it:  > **Media Center**

- 1 Select the picture you want to send.
- 2 Press  > **Use WT Feature > Send Picture.**

A list of contacts that have Walkie-Talkie IDs and are able to receive pictures appears.

- 3 Select the name of the person you want to send the picture to.
- 4 Press the WT button to send the picture.
- 5 When prompted, press the WT button to resume the Walkie-Talkie call.

From the WT Service:

Find it:  >  > **Send Picture**

- 1 Select **A Contact**, or **A Recent Call** to see a list of entries that can receive pictures.
- 2 Select the entry containing the Walkie-Talkie ID you want to send the message to.
- 3 Select the picture you want to send.
- 4 Press the WT button to send the picture.
- 5 Once picture has been sent, when prompted press the WT button to resume the call.

Receive a picture

When someone sends you a picture, your phone emits a tone or vibrates and a message appears asking if you want to accept the picture.

Pictures you receive are saved to your phone's memory. They are accessible through **Media Center**.

When you see a message asking if you want to accept the picture, press **Yes** to accept or **No** to decline.

Tip: If you want to stop the transmission before it is finished, press .



Note: The first time you accept a stored picture after turning the phone on, **Picture Fees May Apply. Continue?** appears and you are prompted to respond. Press  under **Yes** to accept the picture.

Clear a picture from the display

If you want to clear a picture from your phone's display while still on a call, press  > **Clear Screen**.

The picture will not appear on the display again the next time you receive a call from person who sent it. This does not delete the picture from the **Media Center**.

Send my info

- 1 While in a Walkie-Talkie Call press  > **Send via WT**, and push the WT button to send.
or
- 2 From the home screen press  > **My Info** >  > **Send via WT** and push the WT button to send.

Set my info sending option

You can control what portion of the information in **My Info** is sent and whether it is sent automatically in



every call or only when you choose to send it.



Find it:  >  > **Configure** > **WT My Info** > **Info to Send**

- 1 Select or remove the fields you want to send.
- 2 Press  under **Done**.

The information your phone sends always includes **My Name** and **Walkie-Talkie**. You may also send **Line 1**, **Line 2**, **Carrier IP**, and **Circuit Data** depending on your sending options.

Automatic sending

To control whether you send your information automatically:





Find it:  >  > **Configure** > **WT My Info** > **Auto Send**

- 1 Select **On** or **Off**.

When you make a call in which your information is sent automatically, the name you entered in the **My Name** field of **My Info** appears on the display of the

recipient's phone, even if your name and Walkie-Talkie ID are not stored in the recipient's Contacts.

Send contact information

- 1 While in a Walkie-Talkie Call press  > **Use WT Feature**.
- 2 Select **Send Contact** and select the contact information you want to send.
- 3 Push the WT button to send.
or
- 1 From the home screen press  >  > **Send Contact**.
- 2 Enter the Walkie-Talkie ID number of the person you want to send the Contact information to or press  under **Browse**.
- 3 Select from **Recent Calls, Contacts,** or **Memo**.

- 4 Select the contact information you want to send and push the WT button.

Turn WT Features on and off



You can turn your phone's ability to send and receive messages, pictures, and Datebook events on and off.

You cannot turn your phone's ability to send and receive My Info and contact information on and off.

Find it:  >  > **Configure**

- 1 Select **On/Off WT**.
- 2 Check or uncheck **Messages, Pictures** and/or **Events**.

One touch WT

Find it:  >  > **Configure** > **One Touch WT**

One Touch WT sets your phone to do any of the following each time you press the WT button from the home screen:

option
Off: Nothing happens when you press the WT button from the home screen.
Last Call: Call the most recent Walkie-Talkie ID on the recent calls list.
Assigned No.: Call a Walkie-Talkie ID you assign. Enter the number using your keypad, or press  under Search . Select Contacts , Recent Calls , or Memo .
WT Service: Go to WT Service. See “WT service” on page 38.

option
Send Message: Go to the first screen to send a message.
Send Picture: Go to the first screen to send pictures. See “Send pictures” on page 33.
Send Event: Go the first screen to send a Datebook event.
Send My Info: Go to the first screen to send My Info. See “Send my info” on page 35.
Send Contact: Go to the first screen to send a contact. See “Send contact information” on page 36.

WT service



The **WT Service** lets you quickly access WT features, and other Walkie-Talkie call features, from the main menu.

You can also access the Quick WT feature and set the One Touch WT feature.

Find it:  > 

- 1 Select **Send Picture**, **Send Event**, **Send My Info**, or **Send Contact**. After choosing what WT item you are sending, select a contact and press the WT button to send.
or
- 2 Select **Configure** to configure your **WT My Info**, **One Touch WT**, or **On/Off WT Features**.

MMS





Multi-Media Messaging Service (MMS) lets you send and receive messages that may include text, pictures and audio recordings.

Note: If your service provider offers text messaging in addition to MMS, you will have a separate **Inbox**, **Outbox**, and **Drafts** Folder for Text Messages See “Text messages” on page 23.

Create a message

Shortcut: From the home screen press  under **Msgs** > **[Create Message]**.

or

Find it:  >  > **[Create Message]**



Select **To** and add the phone number or email address or select from **Contacts** or **Recent Calls** and press  under **Back**.

Tip: To remove a phone number or email address from the list of message recipients, scroll to the phone number or

email address and press  under **Remove**.

When you are finished addressing the message, press  under **Back**.

To enter or edit the body of the message:

- 3 Select **Mesg** and enter text or press  under **QNotes** to select a pre-written quick note.
- 4 Press  and  under **Send**.

More message options



To view more message fields in a message you are creating, select**MORE**..... or press  under **More**.

option
Subject: Create or edit the subject line.
Attach: Attach a picture, audio file or voice record.
Cc: Send a copy of this message to someone else.
Auto Replies: Allows you to create a list of possible short answers for the recipient to choose when replying to your message.
Priority: Set priority Normal or High .
Report: Set receipt confirmation On Delivery .
Valid Until: Set a date after which attempts to deliver the message end, or press  under No Date .

Reply to a message

You can reply to a message while you are viewing it, or while a previously viewed message is highlighted in the message center. You cannot reply to unread messages.

To reply to a message:



- 1 View the message you want to reply to.
- 2 To reply to the sender only, press  under **Reply** or if you wish to include all the people copied in the message, press  under **Reply All**.

A list of short phrases appears. Select any of these phrases to add it to your messages or select **[Create Reply]**.

- 3 Edit any message fields you want to change.
- 4 Press  under **Send**.

Quick notes

When you are filling in the **Message** and **Subject** message fields, you can add ready-made words or short phrases called Replies. After you add these words or phrases, you can edit them as you would any other text.

- 1 While you are creating a message, scroll to or select **Message** or **Subject**.
- 2 Press  under **Replies**.
Select the Reply you want to insert into the message.
- 3 Press  under **Send**.

Attach a picture, audio and voice recording

You can attach one or more pictures, audio or voice recordings from your phone into the body of the message. You can include text in the body of your message in addition to these items.

While you are filling in the **Attach** field, press **[New] > Browse Pictures** or **Browse Audio**.

A list of available pictures, audio and voice recordings appears.

Select the picture, audio or voice record you want to attach.



Tip: To view or listen to the item before attaching it, highlight it and press **Preview**.

Note: You can only attach audio files and pictures if they are not forward locked and if their DRM settings do not prevent you from sending.

Forward locked items are usually copyright protected, and you cannot share them with anyone, such as in Walkie-Talkie calls or by uploading them from your phone.

Capture a new picture



You can capture a new picture to send with a message:

- 1 From Contacts, Press .
- 2 Select **Capture Picture**.
- 3 Press  under **Capture Picture**.
- 4 Press  under **Save**.

The picture is attached to the message and is saved in the Media Center.

Create a new voice record

You can create a new voice record to send with a message:

- 1 From Contacts, Press .
- 2 Select **Record Voice**.
- 3 Say the message you want to record into the microphone.
- 4 When you are finished recording, press .

The voice record is attached to the message and saved to the list of voice records.

Remove an attachment

To remove an attachment in a message you are creating:

- 1 Select **Attach**.
- 2 Scroll to the attachment you want to remove.
- 3 Press  > **Unattach**.

Drafts

While you are creating a message, you can save it in the drafts folder before you send it.

You can view, edit, send, or delete saved drafts.

Save a message in the drafts folder

From the Message center press  > **Save**.

You can continue to create the message. The version you saved in the drafts folder will not change.

Send a draft

Shortcut: From the home screen press  under **Msgs > Drafts**.

- 1 Select the draft you want to send.
- 2 Press  under **Send**.



Edit a draft

Shortcut: From the home screen press  under **Msgs > Drafts**.

Select the draft you want to edit and press .

Delete a draft

When you send a draft, it is removed from the drafts folder.

To delete a message in the drafts folder without sending it, scroll to the message you want to delete and press  under **Delete** and  under **Yes**.

Outbox

Messages you have sent or tried to send are stored in the Outbox.

Forward items from the outbox

Shortcut: From the home screen press  under **Msgs > Outbox**.

- 1 Scroll to the message you want to forward.
- 2 Press  > **Forward**.
- 3 Edit and send your message.

Resend

If a message was not sent from your handset, you can resend it.

Shortcut: From the home screen press  under **Msgs > Outbox**.

- 1 Scroll to the message you want to resend.
- 2 Press **Resend**.

Note: If your message was sent successfully, **Resend** will not appear as an option.



Check delivery status

If a message was successfully sent and you set the message to give a report confirming delivery, you can check the delivery status:

Shortcut: From the home screen press  under **Msgs > Outbox**.



- 1 Scroll to the message you want to view.
- 2 Press  > **Delivery Status**.

Delete a message

- 1 Scroll to the message you want to delete.
- 2 Press  under **Delete**.
or
- 3 Press  > **Delete Multiple**.
- 4 Select the message or messages you want to delete.
- 5 Press  under **Delete** to confirm.

Receive a message

When you receive a message, a message notification appears on the display.

- 1 To view the message press .
- 2 If the message fills more than one screen, use the navigation key  to scroll down and read the remaining text.

Message notifications

When you receive a message, your phone notifies you with text on the display, a notification tone or vibration.

You can access the message or dismiss the notification.



If you dismiss the notification, the message is not deleted. It can be accessed through the message center.

If you are not on a phone call when you receive a message, your phone sounds a notification tone every 30 seconds until you access the message or dismiss the alert.

If you are on a call when you receive a message, your phone may sound a notification tone during the call or after you end the call, depending on how you set your notification options.

Set notification options

To control whether your phone sounds message notification tones while you are on a phone call:

Find it:  >  > **Phone Calls** > **Notifications.**

Select from the following options:

option
Receive All: Tones sound during calls for all types of messages.
Msg Mail Only: Tones sound during calls for mail messages; tones for all other types of messages are held until you end calls.
Delay All: Tones for all types of messages are held until you end calls.
Note: Delay All is the default setting.

Tip: To set notification options during a call press  > **Call Setup** > **Notifications.**

Embedded objects and attachments

Messages may contain pictures or audio recordings as part of the body of the message or as attachments.

If a message contains pictures or audio recordings in the body of the message, highlight each picture or audio recording to view or play it.

If a message contains a picture or audio recording as an attachment, open the attachment to view the picture or play the audio recording.

Open attachments

- 1 View the message.
- 2 Highlight the attachment you want to open and press . Attachments appear at the end of a message.

Note: Attachments that are of an unknown type cannot be opened, but they can be deleted.



View received messages from the message center

Shortcut: From the home screen press  under **Msgs > Inbox**.

Use auto replies

If the message you are replying to was sent with auto replies, it contains a numbered list of possible replies for you to send. Press the number of the reply you want to send. The reply is sent immediately without further action.

Delete unread messages



- 1 Scroll to the message you want to delete.
- 2 Press  under **Delete**.
- 3 Press  under **Yes** to confirm.

Forward a message

- 1 Press  > **Forward**.
- 2 Create and send your message. Embedded objects and attachments are included when you forward a message.

Lock and unlock messages

Locked messages cannot be deleted until you unlock them.

- 1 View the message you want to lock or unlock.
- 2 Press  > **Lock Message**
or  > **Unlock Message**.

Call a number in a message



If a message you receive contains a phone number or Walkie-Talkie number ID in the From field, the To field, the Cc field, the subject line, or the body of the message, you can call or send a call alert to that number.

Send a call alert

- 1 View the message.
- 2 Highlight the Walkie-Talkie number you want to alert.
- 3 Press  > **Alert**.
- 4 Push the WT button.

Store message information to contacts

If a message you receive contains a phone number, Walkie-Talkie number, or an email address in the From field, the To field, the Cc field, the subject line, or the body of the message, you can store this information to Contacts.

- 1 View the message.
- 2 Highlight the number or email address you want to save.
- 3 Press  > **Save Number** or  > **Save Email**.
- 4 To store the number or email address as a new entry, select **[New Contact]**.

To store the number or email address to an existing entry, select the entry.

- 5 With the Contacts type field highlighted, scroll left or right to display the Contacts type you want

to assign the number or email address.

- 6 Press  under **Done**.

Go to a website



If a message contains one or more website URLs, you can go to that website.

- 1 View the message.
- 2 Highlight the website URL you want to go to.
- 3 Press  > **Go To Website**.

Note: The entire URL must appear in the message to allow you to open the website.

Save an embedded picture or audio recording

To save a picture or audio recording that is part of the body of a message you receive:



- 1 View the message.
- 2 Highlight the picture or audio recording you want to save.
- 3 Press  > **Save Picture** or  > **Save Audio**.

The item will save in the default storage location.

Note: Some types of pictures and audio recordings can be viewed or played, but not saved.

Delete an embedded picture or audio recording

To delete a picture or audio recording that is part of the body of a message you receive:

- 1 View the message.
- 2 Highlight the picture or audio recording you want to delete.
- 3 Press  > **Delete Picture** or  > **Delete Audio**.

Save attachments

- 1 View the message.
- 2 Highlight the attachment you want to save.
- 3 Press  > **Save Attachment**.

Selected items save to the default storage location.

Note: Some types of pictures and audio recordings can be viewed or played, but not saved. You may save pictures and audio recordings from slide shows individually as you view or listen to them.

Save a picture

- 1 View the slide show.
- 2 When the picture you want to save appears, press  > **Save Picture**.

Save audio

- 1 View the slide show.
- 2 Press  > **Save Audio**.
- 3 If the slide show contains more than one audio recording, a list of the audio recordings appears. Select the audio recording you want to save.

Message transmission

After you start to send a message you have created or start to download a message you have been sent, you can still stop the message transmission from being completed.

With the flip closed, press the smart key on the top . Opening or closing the flip does not interrupt message transmission.

Customize MMS messages

Find it:  >  >  > **Setup**

This option is available from many context-sensitive menus when you are using Messaging.

The Setup menu lets you customize Messaging for your handset with the following options:

option
Friendly Name: Enter text here to create a friendly name. Your friendly name is the name displayed in the From field on other iDEN handsets when they receive messages from you.
Signature: Enter text here to create a signature. Your signature is text that is automatically inserted at the end of all messages you create. You can edit the text before sending the message.

option
Quick Notes: Lets you create new Quick Notes and edit or delete Quick Notes you have created.
Replies: Lets you create new reply phrases and edit or delete reply phrases you have created.
Cleanup: Controls how long messages remain in the Inbox and Sent Items before they are deleted.
Downloads: Controls whether your phone automatically downloads new messages when they arrive, or only after you respond to a prompt or read the message from the Inbox. Set this option to Automatic if you want your phone to download new messages automatically; set the option to Manual if you want your phone to prompt you before downloading new messages.
Memory Size: Shows the total amount of Used , Free , and total Capacity of the phone's memory.

New quick notes and reply phrases

Create quick notes

- 1 From the Setup menu, select **Quick Notes** or **Replies**.
- 2 Select **[New Quicknote]** or **[New Reply]**.
- 3 Enter text from the keypad.



Edit quick notes

You can edit only Quick Notes and reply phrases you have created.

- 1 From the Setup menu, select **Quick Notes** or **Replies**.
- 2 Select the Quick Note or reply phrase you want to edit.
- 3 Edit the text.

Delete only quick notes and reply phrases you have created

- 1 From the **Setup** menu, select **Quick Notes** or **Replies**.

- 2 Scroll to the Quick Note or reply phrase you want to delete.
- 3 Press  under **Delete**.
- 4 Press  under **Yes** to confirm.

Cleanup

The **Cleanup** option controls how long messages remain in the **Inbox** and **Outbox** before they are deleted. You set the cleanup option for the Inbox and Outbox separately.

The cleanup option only deletes unlocked read messages from the Inbox, and sent messages from Sent Items for MMS.

Find it:  >  >  > **Setup** > **Cleanup**

- 1 Select **Inbox** or **Sent Items**.
- 2 Choose a cleanup option from the following list:

option
Off: Messages are never automatically deleted.

option

5 Messages: If you have more than 5 messages, messages are deleted in the order they were received, starting with the oldest, until 5 are left.

10 Messages: If you have more than 10 messages, messages are deleted in the order they were received, starting with the oldest, until 10 are left.

With these options, messages are deleted in the order they were received, starting with the oldest, until the selected number are left.



1 Day: Messages are deleted if they are older than 1 day.

3 Days: Messages are deleted if they are older than 3 days.

With these options, messages are deleted when you exit the message center after setting the option.

option



Custom: Lets you create a clean-up option of up to 99 messages or 99 days.

- 3 Press  under **Yes** to automatically delete messages now or press  under **No** to delete messages later.

Delete multiple or all messages

To delete multiple messages, all read and unread unlocked messages from the Inbox, all messages in the Drafts folder, or all successfully sent messages in the MMS Outbox.

Find it:  > 

- 1 Select **Inbox**, **Drafts**, or **Outbox**.
- 2 Press  > **Inbox**, **Drafts**, or **Outbox** >  > **Delete Multiple**, and check the messages you want to delete.

or

Select **Delete All** and press  under **Yes** to confirm.

Note: Locked messages cannot be deleted from the Inbox.

Bluetooth®

Your phone supports the use of wireless Bluetooth headsets.

Find it:  > 

The Bluetooth connection menu contains an option to search for audio devices.

Turn Bluetooth on or off

You can turn your phone's Bluetooth feature on or off. While Bluetooth power is on, your phone can communicate with other devices.

Find it:  >  > **Setup > Power > On**

- 1 Select **Name** if you wish to assign a name to your headset.



- 2 Select **Find Me Time** to determine the amount of time in which your handset can be found by other Bluetooth devices.

Tip: You can turn off Bluetooth if you want to prolong battery life or if you enter an area where Bluetooth is prohibited.

Note: When the Bluetooth connection is activated, a Bluetooth LED indicator will be lit above the external display.

Make a Bluetooth connection

Connect your phone with a Bluetooth headset

Find it:  >  > **Hands Free > [Find Devices]**

- 1 Follow the instructions on your Bluetooth headset to set it up to be found.
- 2 Once your Bluetooth headset is set to be found press  on your handset. Your phone will scan the

Bluetooth headset until it finds it. Press  when you see the name of the Bluetooth headset on your screen.

- 3 Your phone requires that you create a bond in order to connect with a Bluetooth headset. Press  under **Yes** when you are prompted to bond with the headset.
- 4 Enter the Bluetooth pass key.

Some Bluetooth devices ship with Bluetooth PINs. Please refer to your Bluetooth device's user guide to locate this information.

If a device ships without a Bluetooth PIN, then refer to its user guide to set the PIN on that device. To establish a connection to that device, enter the same PIN for both your phone and the device. For example, if you enter 1234 as the device's PIN, then enter 1234 as your phone's PIN.

- 5 Press  under **Ok**.

Note: This handset offers a Bluetooth auto pair feature with auto pair compatible Motorola devices. When bonded via Bluetooth with a certain device, the pin will not be required.

Connect Your Phone with Another Device

Find it: > > **Link To Devices**



- 1 Select the device you want from the list of found devices on your screen.
- 2 Create a bond if you are prompted to do so.

Tip: If you have previously connected to a device, the device will be stored on your phone so you can connect with it easily.

Use Bluetooth during a call

You can connect with available Bluetooth devices during a call.

Note: If the **Handsfree Devices** list contains only one device, then your phone will automatically try to connect to that device.

- 1 While in a call, press  > **Use Bluetooth.**
- 2 Press  under **Yes** to power On Bluetooth.
- 3 Select the audio device you want to connect to from the list of **Handsfree Devices.**

Send information via Bluetooth

You can use your phone to send Contacts entries, or Datebook events to another Bluetooth device.

The receiving device must be within 32 feet (10 meters) of your phone in order to connect with yours.

Note: Files sent or received may be up to 200 kb, depending on your service provider.



Send contacts

Shortcut: From the home screen press  under **Contacs.**

- 1 Select the contact you want to send.
- 2 Press  > **Send Via... > Bluetooth.**
- 3 Select the device you want to transfer the contact information to.
or
Search for the device by selecting **[Find Devices].**
- 4 If prompted, bond with the device.
Your phone connects with the device and transfers the contact.

Send a datebook event

Find it:  > **Datebook**

- 1 Select the datebook event you want to send.
- 2 Press  > **Send Via... > Bluetooth.**
If the event you select repeats, then you will be prompted to choose

whether to send the selected instance of the event or all instances of the event.

To send only the selected instance of the event, select **This Event Only**.

or

To send all instances of the event, select **Repeat Events**.

- 3 Press under **Yes** to power On Bluetooth.

- 4 Select the device you want to transfer the contact information to.

or

Search for the device by selecting **[Find Devices]**.

- 5 If prompted, bond with the device.

Your phone connects with the device and sends the datebook event.

Basics

See page 3 for a basic phone diagram.

Display

The *home screen* shows when you turn on the phone. To dial a number from the home screen, press number keys and .

Note: Your home screen may look different.

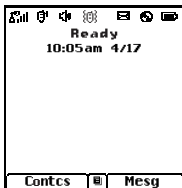



Soft key labels show the current soft key functions. For soft key  locations, see page 3.

Status indicators

Status indicators are shown at the top of the home screen:



- Signal Strength Indicator:** Vertical bars show the strength of the network connection. You can't make or receive calls when  or  shows.
- Active Phone Line:** 1 indicates phone line 1 is ready to make calls.
- Speaker Off:** Sounds associated with Walkie-Talkie calls are set to

come through the earpiece rather than through the speaker.

- 4 Ringer Off:** Your phone is set to not ring.
- 5 Message Indicator:** Shows when you receive a text message. 
- 6 Packet Data:** Your handset is ready to transfer packet data or is transferring packet data.
- 7 Battery Charge Indicator:** A fuller battery indicates a greater charge. Recharge the battery when your phone shows **Low Battery**.

Text entry

Some features let you enter text.

Your phone provides convenient ways to enter words, letters, punctuation, and numbers whenever you are prompted to enter text (for example, when adding a Contacts entry or when text messaging).

Change the character input mode:

- When you see a screen where you can enter text, press  to change the character input mode.
- Select one of the following options:

entry modes	
Alpha	Press a key several times for each character.
Word	Enter words using a predictive text entering system that lets you enter a word with fewer keypresses.
Symbols	Enter symbols.
Numeric	Enter numbers by pressing the numbers on the keypad.
Languages	Lets you select the input language.

Tip: When entering text, press and hold  to change letter capitalization (**Abc** > **ABC** > **abc**).

Word mode

Word English Text Input lets you enter text into your phone by pressing keys just once per letter.

Word English Text Input analyzes the letters you enter using an intuitive word database and creates a suitable word. (The word may change as you type.)

Enter a word using Word Character Input:

- 1 Select the **Word** character input mode.
- 2 Press the corresponding keys once per letter to enter a word (for example, to enter the word **Jeff**, press **5** **3** **3** **3**). (If you make a mistake, press **⌫** under **Delete** or **✕** to erase a single character. Press and hold **⌫** under **Delete** or **✕** to delete an entire entry.)
- 3 To accept a word and insert a space, press **#**.

Alpha mode

Enter characters by tapping the keypad:

- 1 Select the **Alpha** mode.
- 2 Press the corresponding keys repeatedly until the desired letter appears. (For example, to enter the word **Jeff**, press **5** once, **3** two times, **3** three times, and **3** three times again. If you make a mistake, press **⌫** under **Delete** to erase a single character. Press and hold **⌫** under **Delete** to erase an entire entry.)

By default, the first letter of an entry is capitalized and the following letters are lowercased. After a character is entered, the cursor automatically advances to the next space after two seconds or when you enter a character on a different key.

Characters scroll in the following order:

characters	
1	.?!,@&:;"-()'ı%£\$¥
2	ABC2ÁÃÄÅÇ
3	DEF3ÉÊË
4	GHI4ÎÏ
5	JKL5
6	MNO6ÓÔÕÖ
7	PQRS7ß
8	TUV8ÚÛÜÙ
9	WXYZ9
0	+ - 0 * / \ [] = > < # \$
#	Space
*	Back

Volume

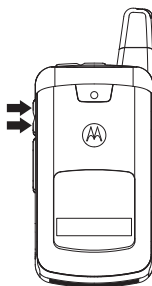

Press the volume keys up or down to:

- turn off an incoming call alert
- change the earpiece volume during calls
- change the ringer volume from the home screen



Tip: You can quickly set your ringer to **Vibrate All** by holding the down volume key in the home screen.

Navigation key

Press the *navigation key*  up, down, left, or right to scroll to items in the display. When you scroll to something, press .

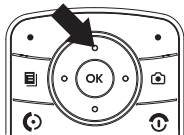

Handsfree speaker

You can use your phone's hands-free speaker to make calls without holding the phone to your ear.

During a call press the speaker key  to turn the hands-free speaker on.

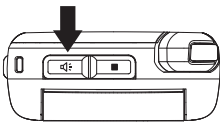

The hands-free speaker stays on until you press the speaker key or end the

call. The next phone call will redirect the audio back to the earpiece.

Lock & unlock phone

Phone Lock — Turns on a feature that locks your phone: **Lock Now** takes effect immediately; **Auto Lock** takes effect when your phone is powered off and then on. An unlock code is required to enable this feature, to unlock the phone, and to set a new unlock code. Contact your service provider for your default unlock code.



Keypad Lock — Locks the phone's keypad, either immediately or automatically after a set period of inactivity.

Lock keypad

You can lock your phone's external keys to prevent accidental key presses.

To lock the external keys automatically after a specified time:



Find it:  > **Settings** > **Security** > **Keypad Lock** > **Auto Lock**.

Tip: You can lock the keypad immediately by pressing  and .

Airplane Mode

Note: Consult airline staff about the use of the Airplane Mode during flight. Turn off your phone whenever instructed to do so by airline staff.

Airplane Mode turns off your phone's calling features in situations where wireless phone use is prohibited, but you can use the phone's other non-calling features when Transmitters turned Off.

Find it:  >  > **Advanced** > **Transmitters**

- 1 Select **Off** to turn on airplane mode.

Accessories

Your phone comes with a Lithium Ion Battery and travel charger.

Various accessories are available for use with your i776 phone, cases, vehicle power charger, data cables, hands-free accessories and more.

To order additional accessories, go to boostmobile.com. You can also contact your Boost Authorized Dealer. For information on Boost retail store locations, go to boostmobile.com.

Wireless local number portability: Bringing your phone number from another carrier

Please contact **Boost Customer Care**

Boost Customer Care

1-888-BOOST-4U (1-888-266-7848) or dial 6-1-1 from your i776 phone.

Customize

Ringtones

To set the ring tone your phone makes when you receive phone calls, call alerts, message notifications, pictures sent using Send via WT or Datebook reminders:



Note: Only ringtones stored in your phone's memory are available in the ringtones list. Not all audio files can be assigned as ringtones.

Find it:  > 

- 1 Make sure **Vibrate All** is set to **Off**.
- 2 Scroll through the list of ringtones and select the one you want to assign. **Vibrate** sets your phone to vibrate instead of making a sound; **Silent** sets your phone to neither vibrate nor make a sound.

Tip: Highlighting a ring tone lets you hear it.

- 3 Select the features you want to assign the ring tone to.
- 4 When you are finished, press **Done**.

Note: This icon  appears on the display if you set your phone to **Silent**. This icon  appears on the display if you set the phone to **Vibrate All**.

Set your phone to vibrate

You can set your phone to vibrate instead of making a sound when you receive all phone calls, Walkie-Talkie calls, call alerts, messages notifications, pictures sent using Send via WT, and Datebook reminders.

Find it:  >  > **Vibrate All**

- 1 Set this option to **On** or **Locked**.

Setting this option to **On** lets you turn **Vibrate All** off by pressing the up volume control. Setting this option to **Locked** requires you to press and hold the up volume control to turn **Vibrate All** off. The **Locked** option helps prevent you from accidentally turning **Vibrate All** off.

To set **Vibrate All** to **On** or **Locked** using the volume controls: Press the volume controls to turn down the volume as far as possible to set **Vibrate All** to **On**. Continue to hold the down volume control to set **Vibrate All** to **Locked**.

To set your phone to vibrate instead of making a sound for some features but not others:

Find it:  > 

- 1 Make sure **Vibrate All** is set to **Off**.
- 2 Select **Vibrate** from the list of ringtones.

- 3 Select the features you want to set to make no sound.
- 4 When you are finished, press  under **Done**.

Wallpaper

Set a photo or picture as a wallpaper (background) image in your phone's home screen or throughout all menu screens.



Find it:  >  > **Display/Info** > **Wallpaper** > **Wallpaper**.

To select a wallpaper image scroll through the list of pictures and press  to select the picture of your choice.

Note: You can set the wallpaper to change automatically after a certain period of time by turning on the **Auto Cycle** feature located in the Wallpaper menu.

Backlight

Set the amount of time that the display and java apps. backlights remain on, or turn off the backlight feature to extend battery life.

Find it:  >  > **Display/Info > Backlight**

LED indicators

You can turn off the bluetooth and messaging indicators on the external display.

Find it:  >  > **Display/Info > Backlight > Bluetooth LED or Messaging LED > Off**

Datebook

Find it:  > **Datebook >  > Setup**

You can view or change these options:

option
Start View: Sets Datebook to start in day view, week view, or month view when you access Datebook.
Daily Begin: Sets the beginning of your day. This is the earliest time of day displayed in week view, if you have a 12-hour day view.
Delete After: Sets the amount of time Datebook waits to delete an event after it occurs.
Time Shift: Lets you shift the times of all Datebook events. This is useful if you are traveling to a different time zone.
Alert Timeout: Sets the amount of time a tone continues to sound when you receive a Datebook reminder.
Clock: Controls whether the time and date appear on the home screen; sets time and date format.

Hide or show location information



Your phone is equipped with a Location feature for use in connection with location-based services that may be available in the future.

The Location feature allows the network to detect your position. Turning Location off will hide your location from everyone except for your local emergency response center.

Note: Turning Location on will allow the network to detect your position using GPS technology, making some applications and services easier to use. Turning Location off will disable the GPS location function for all purposes except 911, but will not hide your general location based on the cell site serving your call. No application or service may use your location without your request or permission.

GPS-enhanced 911 is not available in all areas.

Set your privacy options

Find it:  >  > **Privacy**

Select **Restricted**, **Unrestricted**, or **Ask Access**.

Calls

To make and answer calls, see page 20.

Recent calls

The **Recent Calls** list contains information associated with calls you have made and received and call alerts you have received.

When you send or receive Walkie-Talkie calls, the Recent Call list contains the following WT items with those calls:

- Messages
- Pictures
- Events
- My Info
- Contacts

The recent calls list displays up to 20 of the most recent calls and call alerts.

Find it:  > 

Tip: You can also access the Recent Calls list by pressing the navigation key







down.

- 1 Scroll through the list.
- 2 Highlight the item you want to view or perform some action on.
- 3 To view more details of the item press .

Store an item to contacts from recent calls

Phone calls, Walkie-Talkie calls, My Info received from other phones, or Contacts entries received from other phones can be stored to the Contacts list from the Recent Calls list.

Find it:  > 

- 1 Scroll to or select the item you want to store.
- 2 Press  under **Save** to store the information as a new entry in the Contacts list.
- 3 Press  under **Done** to save your changes.
- 2 Assign a name, phone number and select **[Options]**.
- 3 Select **Voice Name** and follow the prompt to record the voice name.
- 4 Press  under **Back** and  under **Done** to save the entry.

Redial

To redial your last outgoing phone call, press and hold  or push the WT button if it was a Walkie-Talkie call.

Voice names

You can place calls by speaking commands to your phone if you have previously assigned a voice name to your contacts.

Assign voice names to contacts

- 1 Press  under **Contacs** and select **[New Contact]**.

Place a call using voice command

- 1 From the home screen press and hold the speaker key  until you are prompted to say the voice name.

The handset will automatically place the call.

Caller ID

Caller ID allows people to identify a caller before answering the phone by displaying the number of the incoming call. If you do not want your number displayed when you make a call, just follow these easy steps.



To block your phone number from being displayed for a specific outgoing call:

- 1 Press **[*]** **[6]** **[7]**.
- 2 Enter the number you want to call.
- 3 Press **[☎]**.

To permanently block your number, call your service provider's Customer Care.

Call forward

Call forwarding sends calls to the phone numbers you specify. You can forward all calls to one number or forward missed calls to different numbers depending on the reason you missed the call.

Find it: **[☰]** > **»**

- 1 To forward all calls select **All Calls** and select **To** to enter the phone number you want all your calls forwarded to.
or
- 2 You can specify a forwarding number for each type of missed call

by selecting **Detailed** and choosing the following options:

If Busy: When your handset is on a call or transferring data.

If No Answer: When you do not answer on the first 4 rings.

If Unreachable: When your handset is out of coverage or powered off.

Emergency calls

Your service provider programs one or more emergency phone numbers that you can call under any circumstances, even when your phone is locked or the SIM card is not inserted.

Note: Emergency numbers vary by country. Your phone's preprogrammed emergency number(s) may not work in all locations, and sometimes an emergency call cannot be placed due to network, environmental, or interference issues.

Your phone supports emergency calling. Emergency phone calls can be made even when your SIM card is blocked or not in your phone.

Dial 911 or your local emergency number to be connected to an emergency response center. If you are on an active call, you must end it before making an emergency call.

When you make an emergency call, your phone's GPS Enabled feature can help emergency service personnel find you, if you are in a location where your phone's GPS antenna has established a clear view of the open sky and your local emergency response center has the equipment to process location information. Because of the limitations of this feature, always provide your best knowledge of your location to the emergency response center when you make an emergency call.

Note: Emergency calls cannot be placed while the keypad is locked.

Note: If you have not registered on the network, emergency calls cannot be placed while your SIM card is in your phone.

International calls



If your phone service includes international dialing, press and hold 0 to insert your local international access code (indicated by +). Then, press the keypad keys to dial the country code and phone number.

Speed dial

Each phone number stored in Contacts is assigned a Speed Dial number, which you can use to call that number.

- 1 From the home screen, use the keypad to enter the Speed Dial number assigned to the phone number you want to call.
- 2 Press **[#]**.

3 Press .

Turbo dial

The first nine entries in your contacts are set for turbo dial. They can be called by pressing and holding the speed dial number (1 through 9).

Voice mail

Note: To receive voice mail messages, you must first set up a voice mail account with your service provider.





Receive a message

When you receive a voice mail message, **New VoiceMail Message** appears on the display.

To check voicemail messages press  under **Call**.

To dismiss the message notification:

If the flip is closed, press the smart key  on the top.



If the flip is open, press , **Back**, or close the flip.

If the caller leaves a message, this icon  appears on the display, reminding you that you have a new message. Additionally, the Messaging LED indicator will light up.





Note: By default, the Messaging LED indicator will turn off after 30 seconds.

Other features







Advanced calling

feature	
call waiting	<p>Find it: To accept the second call and put the active call on hold press  under Yes.</p> <p>To accept the second call and end the active call press .</p> <p>Your phone rings with the second call for you to answer.</p>











feature	
flip activation	<p>To make your handset to answer and end calls by opening and closing the flip press  >  ></p> <p>Phone Calls > Flip Activation.</p> <p>Select Flip To Ans > On and Flip to End > On.</p>
any key answer	<p>To answer phone calls by pressing any key on the keypad press  >  ></p> <p>Phone Calls > Any Key Ans > On.</p>

Contacts

feature	
edit/delete contact entry	Press  under Contacts . Select a contact and press  > Edit . Change the desired content and press  under Done .
set ringer ID	Press  under Contacts . Select a contact and press  > Edit > Ringer . Select desired ringer, press  under Back , and  under Done .

Datebook

feature	
create datebook events	To create a new Datebook event press  >  > [New Event] .
see datebook event	To see a calendar event press  >  >  left or right to see the day and  up or down to see the events.
event reminder	When an event reminder occurs press  under View . Press  under Back to close the reminder.

feature

receive datebook events via WT

To view the information while still in the Walkie-Talkie call press .

The 5 most recent events received from a Walkie-Talkie ID are stored with the that Walkie-Talkie ID on the recent calls list.

To store events to the Datebook press  under **Save** while viewing the event you want to store.



GPS

To improve GPS performance:

- Stay in the open,
- Move away from other electrical or electronic devices
- Remain stationary.
- Avoid covering the antenna with your hands.

feature



view approximate location

To see your approximate location press  >  > **Position**. Scroll to view the entire screen.

To recalculate position press **Rfrsh**. This may take several minutes.

feature

set GPS privacy options

To set the level of privacy for your GPS system press  >  > **Privacy.**

If your GPS PIN security feature is enabled, enter your GPS PIN and select the privacy option you want.

feature

change GPS PIN

Note: Your default GPS PIN is 0000.

To change your GPS PIN press  >  > **Security > Change Passwds > GPS PIN.**



Enter the current GPS PIN and enter the new 4- to 8-digit GPS PIN. Re-enter the new 4- to 8-digit GPS PIN to confirm.

Handsfree

Note: The use of wireless phones while driving may cause distraction. Discontinue a call if you can't concentrate on driving. Additionally, the use of wireless devices and their accessories may be prohibited or restricted in certain areas. Always obey the laws and regulations on the use of these products



feature

speaker-phone







To activate the speakerphone while driving press and hold the speakerphone key 
.



feature

auto answer

To automatically answer calls when connected to a car kit or headset press  >  > **Phone Calls** > **Auto Ans.** Select the amount of rings before answering.

Personalize

feature	
language	To set the language of your menu press  >  > Display/Info > Language.
backlight time length	To select how long the display screen and keypad are backlit press  >  > Display/Info > Backlight.
menu style	To show the Main Menu as graphic icons or a text-based list press  >  > Display/Info > Menu View.

feature	
clock display	To display the clock on your home screen press  >  > Display/Info > Clock > Display > On.

PC applications

feature	
other PC applications	For a list of complete PC applications visit www.motorola.com/support

TTY



feature	
turn On TTY feature	From the home screen press > > Phone Calls > TTY > Use TTY > On .
choose TTY mode	From the home screen press > > Phone Calls > TTY > Type . Select from TTY , VCO or HCO .
change the TTY baud rate	From the home screen press > > Phone Calls > TTY > Baud . Select 45.45 or 50.00 .

feature	
change TTY mode during a call	While in the TTY call, press > In Call Setup > TTY > Type . Select from TTY , VCO or HCO .

Security

feature	
phone lock	To lock the phone press [Home] > [X] > Security > Phone Lock > Lock Now or Auto Lock .
keypad lock	To lock the keypad press [Home] > [X] > Security > Keypad Lock > Lock Now or Auto Lock . Shortcut: To lock the keypad press [Home] > [X].
enable SIM PIN	To enable SIM PIN, press [Home] > [X] > Security > SIM PIN > On .

feature	
change SIM PIN	To change the SIM PIN, press [Home] > [X] > Security > Change Passwds > SIM PIN .

Note: You can make emergency calls on a locked phone (see page 73). A locked phone still rings or vibrates for incoming calls or messages, but you need to unlock it to answer.



MOTOROLA

Important Safety and Legal Information

Safety and General Information

This section contains important information on the safe and efficient operation of your mobile device. Read this information before using your integrated multi-service portable radio.*

Exposure to Radio Frequency (RF) Energy

Your phone contains a transmitter and receiver. When it is ON, it receives and transmits RF energy. When you communicate with your phone, the system handling your call controls the power level at which your phone transmits.

Your Motorola phone is designed to comply with local regulatory requirements in your country concerning exposure of human beings to RF energy.

Portable Radio Product Operation and EME Exposure

Your Motorola radio product is designed to comply with the following national and international standards and guidelines regarding exposure of human beings to radio frequency electromagnetic energy (EME):

- United States Federal Communications Commission, Code of Federal Regulations; 47 CFR part 2 sub-part J.
- American National Standards Institute (ANSI) / Institute of Electrical and Electronics Engineers (IEEE). C95. 1-1992.
- Institute of Electrical and Electronics Engineers (IEEE). C95. 1-2005 Edition.*
- International Commission on Non-Ionizing Radiation Protection (ICNIRP) 1998.
- Ministry of Health (Canada). Safety Code 6. Limits of Human Exposure to Radiofrequency Electromagnetic Fields in the Frequency Range from 3 kHz to 300 GHz, 1999.
- Australian Communications Authority Radiocommunications (Electromagnetic Radiation - Human Exposure) Standard 2003.
- ANATEL, Brasil Regulatory Authority, Resolution 303 (July 2, 2002) "Regulation of the limitation of exposure to electrical, magnetic, and electromagnetic fields in the

* The information provided in this document supersedes the general safety information in user's guides published prior to May 1, 2006

radio frequency range between 9 kHz and 300 GHz." Attachment to Resolution 303 from July 2, 2002."

Operational Precautions

To assure optimal radio product performance and to be sure that human exposure to RF does not exceed the guidelines set forth in the relevant standards, always follow these instructions and precautions :

Two-way radio operation

Your radio product has been designed and tested to comply with national and international standards and guidelines regarding human exposure to RF electromagnetic energy, when operated in the two-way mode (at the face, or at the abdomen when using an audio accessory) at usage factors of up to 50% talk/50% listen.

Transmit no more than the rated duty factor of 50% of the time. To transmit (talk), push the Walkie-Talkie (WT) button. To receive calls, release the WT button. Transmitting 50% of the time or less, is important because this radio generates measurable RF energy only when transmitting (in terms of measuring for standards compliance).

When using your radio product as a traditional two-way radio, **hold the radio product in a vertical position with the microphone one to two inches (2.5 to 5 cm) away from the lips.**



Product Operation

When placing or receiving a phone call, hold your radio product as you would a wireline telephone. **Speak directly into the microphone.**

If you wear a radio product on your body when transmitting, always place the radio product in a Motorola approved clip, holder, holster, case or body harness. If you do not use a body-worn accessory supplied or approved by Motorola and are not using the radio product in the intended use positions along side the head in the phone mode or in front of the face in the two-way radio mode—or if you hang your device from a lanyard around your neck—keep the device at least 2.5 centimeters (1 inch) from your body when transmitting.

ALL MODELS WITH FCC ID IHDP56HS1 MEET THE GOVERNMENT'S REQUIREMENTS FOR EXPOSURE TO RADIO WAVES.

Your wireless phone is a radio transmitter and receiver. It is designed and manufactured not to exceed the emission limits for exposure to radiofrequency (RF) energy set by the Federal Communications Commission of the U.S. Government. These limits are part of comprehensive guidelines and establish permitted levels of RF energy for the general population. The guidelines are based on standards that were developed by independent scientific organizations through periodic and thorough evaluation of scientific studies. The standards include a substantial safety margin designed to assure the safety of all persons, regardless of age and health.

The exposure standard for wireless mobile phones employs a unit of measurement known as the Specific Absorption Rate, or SAR. The SAR limit set by the FCC is 1.6W/kg.¹ Tests for SAR are conducted using standard operating positions reviewed by the FCC with the phone transmitting at its highest certified power level in all tested frequency bands. Although the SAR is determined at the highest certified power level, the actual SAR level of the phone while operating can be well below the maximum value. This is because the phone is designed to operate at multiple power levels so as to use only the power required to reach the network. In general, the closer you are

to a wireless base station antenna, the lower the power output.

Before a phone model is available for sale to the public, it must be tested and certified to the FCC that it does not exceed the limit established by the government-adopted requirement for safe exposure. The tests are performed in positions and locations (e.g., at the ear and worn on the body) as required by the FCC for each model. The highest SAR value for this model phone when tested for use at the ear is 1.45 W/kg and when tested on the body, as described in this user guide, is 1.35 W/kg during packet data transmission. (Body-worn measurements differ among phone models, depending upon available accessories and FCC requirements.)²

While there may be differences between the SAR levels of various phones and at various positions, they all meet the government requirement for safe exposure.

The FCC has granted an Equipment Authorization for this model phone with all reported SAR levels evaluated as in compliance with the FCC RF exposure guidelines. SAR information on this model phone is on file with the FCC and can be found under the Display Grant section of <http://www.fcc.gov/oet/fccid> after searching on FCC ID IHDP56HS1.

Additional information on Specific Absorption Rates (SAR) can be found on the Cellular Telecommunications Industry Association (CTIA) web-site at <http://www.wow-com.com>.

¹ In the United States and Canada, the SAR limit for mobile phones used by the public is 1.6 watts/kg (W/kg) averaged over one gram of tissue. The standard incorporates a substantial margin of safety to give additional protection for the public and to account for any variations in measurements.

² The SAR information reported to the FCC includes the FCC-accepted Motorola testing protocol, assessment procedure, and measurement uncertainty range for this product.

Approved Accessories

For a list of approved Motorola accessories call 1-800-453-0920, or visit our website at www.motorola.com/iden.

RF Energy Interference/Compatibility

Nearly every electronic device is subject to RF energy interference from external sources if inadequately shielded, designed or otherwise configured for RF energy compatibility. In some circumstances your handset may cause interference with other devices.

Follow Instructions to Avoid Interference Problems

Turn OFF your radio product where posted notices instruct you to do so.

In an aircraft, turn off your radio product whenever instructed to do so by airline staff. If your radio product offers an airplane mode or similar feature, consult airline staff about using it in flight.

Implantable Medical Devices

If you have an implantable medical device, such as a pacemaker or defibrillator, consult your physician before using this radio product.

Persons with implantable medical devices should observe the following precautions:

- ALWAYS keep the phone more than 20 centimeters (8 inches) from the the implantable medical device when the phone is turned ON.
- DO NOT carry the phone in a breast pocket;
- Use the ear opposite the implantable medical device to minimize the potential for interference.
- Turn OFF the phone immediately if you have any reason to suspect that the interference is taking place.

Read and follow the directions from the manufacturer of your implantable medical device. If you have any questions about using your wireless phone with your implantable medical device, consult your health care provider.

Hearing Aids

Some mobile devices may interfere with some hearing aids. In the event of such interference, you may want to consult your hearing aid manufacturer or physician to discuss alternatives.

Other Medical Devices and Health Care Facilities

If you use any other personal medical devices, consult your physician or the manufacturer of your device to determine if it is adequately shielded from RF energy. Turn off your radio product when instructed to do so in hospitals or health care facilities that may be using equipment that is sensitive to external RF energy.

Driving Precautions

Check the laws and regulations on the use of radio products in the area where you drive. Always obey them.

When using your radio product while driving, please:

- Give full attention to driving and to the road. Using a mobile device may be distracting. Discontinue a call if you can't concentrate on driving.
- Use handsfree operation, if available.
- Pull off the road and park before making or answering a call if driving conditions so require.

- Do not place a handset in the airbag deployment area.

Responsible driving practices can be found in the "Smart Practices While Driving" section at the end of this guide and/or at the Motorola Web site: www.motorola.com/callsmart.

Note: The use of wireless phones while driving may cause distraction. Discontinue a call if you can't concentrate on driving. Additionally, the use of wireless devices and their accessories may be prohibited or restricted in certain areas. Always obey the laws and regulations on the use of these products.

Operational Warnings

Obey all posted signs when using mobile devices in public areas.

Potentially Explosive Atmospheres





Areas with potentially explosive atmospheres are often but not always posted, and can include fueling areas such as below decks on boats, fuel or chemical transfer or storage facilities, or areas where the air contains chemicals or particles, such as grain, dust or metal powders.



When you are in such area, turn off your handset, and do not remove, install, or charge batteries unless it is a radio product type especially qualified for use in such areas as "Intrinsically Safe" (for example, Factory Mutual, CSA, or UL approved). In such areas, sparks can occur and cause an explosion or fire.

Batteries and Chargers

Caution: Improper treatment or use of batteries may present a danger of fire, explosion, leakage, or other hazard. For more information, see the “Battery Use and Battery Safety” section in this user’s guide.

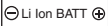
Your battery, charger, or portable radio may contain symbols, defined as follows:

Symbol	Definition
	Important safety information follows.
	Do not dispose of your battery or mobile device in a fire.
	Your battery or mobile device may require recycling in accordance with local laws. Contact your local regulatory authorities for more information.
	Do not throw your battery or mobile device in the trash.
	Your mobile device contains an internal lithium ion battery.

Symbol	Definition
	Do not let your battery, charger, or mobile device get wet.
	Listening at full volume to music or voice through a headset may damage your hearing.

Choking Hazards

Your portable radio or its accessories may include detachable parts, which may present a choking hazard to small children. Keep your device and its accessories away from small children.

Glass Parts

Some parts of your mobile device may be made of glass. This glass could break if the product is dropped on a hard surface or receives a substantial impact. If glass breaks, do not touch or attempt to remove. Stop using your mobile device until the glass is replaced by a qualified service center.

Seizures/Blackouts

Some people may be susceptible to epileptic seizures or blackouts when exposed to flashing lights, such as when playing video games. These may occur even if a person has never had a previous seizure or blackout.

If you have experienced seizures or blackouts, or if you have a family history of such occurrences, please consult with your physician before playing video games or enabling a flashing-lights feature (if available) on your mobile device.

Discontinue use and consult a physician if any of the following symptoms occur: convulsion, eye or muscle twitching, loss of awareness, involuntary movements, or disorientation. It is always a good idea to hold the screen away from your eyes, leave the lights on in the room, take a 15-minute break every hour, and stop use if you are very tired.

Caution About High Volume Usage



Listening at full volume to music or voice through a headset may damage your hearing.

Repetitive Motion

When you repetitively perform actions such as pressing keys or entering finger-written characters, you may experience occasional discomfort in your hands, arms, shoulders, neck, or other parts of your body. If you continue to have discomfort during or after such use, stop use and see a physician.

Service & Repairs

If you have questions or need assistance, we're here to help.

Go to www.motorola.com/iden/support, where you can select from a number of customer care

options. You can also contact the Motorola Customer Support Center at 1-800-453-0920 (United States), 1-877-483-2840 (TTY/TDD United States for hearing impaired).

Motorola Limited Warranty for the United States and Canada

What Does this Warranty Cover?

Note: FOR IDEN SUBSCRIBER PRODUCTS, ACCESSORIES AND SOFTWARE PURCHASED IN THE UNITED STATES OR CANADA

What Does this Warranty Cover?

Subject to the exclusions contained below, Motorola, Inc. warrants its Motorola iDEN Digital Mobile and Portable Handsets ("Products"), Motorola-branded or certified accessories sold for use with these Products ("Accessories") and Motorola software contained on CD-Roms or other tangible media and sold for use with these Products ("Software") to be free from defects in materials and workmanship under normal consumer usage for the period(s) outlined below.

This limited warranty is a consumer's exclusive remedy, and applies as follows to new Products, Accessories and Software purchased by consumers in the United States or Canada,

which are accompanied by this written warranty:

Products Covered	Length of Coverage
Products as defined above.	One (1) year from the date of purchase by the first consumer purchaser of the product.
Accessories as defined above.	One (1) year from the date of purchase by the first consumer purchaser of the product.
Products or Accessories that are Repaired or Replaced.	The balance of the original warranty or for ninety (90) days from the date returned to the consumer, whichever is longer.

Products Covered	Length of Coverage
Software as defined above. Applies only to physical defects in the media that embodies the copy of the software (e.g. CD-ROM, or floppy disk).	Ninety (90) days from the date of purchase.

What is not covered? (Exclusions)

Normal Wear and Tear. Periodic maintenance, repair and replacement of parts due to normal wear and tear are excluded from coverage.

Ornamental Decorations. Ornamental decorations such as emblems, graphics, rhinestones, jewels, gemstones and their settings, and other decorative elements, are excluded from coverage.

Batteries. Only batteries whose fully charged capacity falls below 80% of their rated capacity and batteries that leak are covered by this limited warranty.

Abuse & Misuse. Defects or damage that result from: (a) improper operation, storage, misuse or abuse, accident or neglect, such as physical damage (cracks, scratches, etc.) to the surface of the product resulting from misuse; (b) contact with liquid, water, rain, extreme humidity or heavy perspiration, sand, dirt or the like, extreme heat, or food; (c) use of the Products or Accessories for commercial purposes or subjecting the Product or Accessory to abnormal usage or conditions; or (d)

other acts which are not the fault of Motorola, are excluded from coverage.

Use of Non-Motorola Products and Accessories. Defects or damage that result from the use of Non-Motorola branded or certified Products, Accessories, Software or other peripheral equipment are excluded from coverage.

Unauthorized Service or Modification. Defects or damages resulting from service, testing, adjustment, installation, maintenance, alteration, including without limitation, software changes, or modification in any way by someone other than Motorola, or its authorized service centers, are excluded from coverage.

Altered Products. Products or Accessories with (a) serial numbers or date tags that have been removed, altered or obliterated; (b) broken seals or that show evidence of tampering; (c) mismatched board serial numbers; or (d) nonconforming or non-Motorola housings, antennas, or parts, are excluded from coverage.

Communication Services. Defects, damages, or the failure of Products, Accessories or Software due to any communication service or signal you may subscribe to or use with the Products, Accessories or Software is excluded from coverage.

Software Embodied in Physical Media. No warranty is made that the software will meet your requirements or will work in combination with any hardware or software applications provided by third parties, that the operation of the software products will be uninterrupted or error free, or that

all defects in the software products will be corrected.

Software NOT Embodied in Physical Media.

Software that is not embodied in physical media (e.g. software that is downloaded from the internet), is provided "as is" and without warranty.

Who is covered? This warranty extends only to the first consumer purchaser, and is not transferable.

What will Motorola Do? Motorola, at its option, will at no charge repair, replace or refund the purchase price of any Products, Accessories or Software that does not conform to this warranty. We may use functionally equivalent reconditioned/refurbished/pre-owned or new Products, Accessories or parts. No data, software or applications added to your Product, Accessory or Software, including but not limited to personal contacts, games and ringer tones, will be reinstalled. To avoid losing such data, software and applications please create a back up prior to requesting service.

How to Obtain Warranty Service or Other Information?

To obtain service or information, please call:

Motorola iDEN Customer Services 1-800-453-0920 or 954-723-4910

TTY-877-483-2840

Or visit us online at <http://www.motorola.com/iden/support>

You will receive instructions on how to ship the Products, Accessories or Software, at your

expense, to a Motorola Authorized Repair Center. To obtain service, you must include: (a) a copy of your receipt, bill of sale or other comparable proof of purchase; (b) a written description of the problem; (c) the name of your service provider, if applicable; (d) the name and location of the installation facility (if applicable) and, most importantly; (e) your address and telephone number.

What Other Limitations Are There? ANY IMPLIED WARRANTIES, INCLUDING WITHOUT LIMITATION THE IMPLIED WARRANTIES OF MERCHANTABILITY AND FITNESS FOR A PARTICULAR PURPOSE, SHALL BE LIMITED TO THE DURATION OF THIS LIMITED WARRANTY, OTHERWISE THE REPAIR, REPLACEMENT, OR REFUND AS PROVIDED UNDER THIS EXPRESS LIMITED WARRANTY IS THE EXCLUSIVE REMEDY OF THE CONSUMER, AND IS PROVIDED IN LIEU OF ALL OTHER WARRANTIES, EXPRESS OR IMPLIED. IN NO EVENT SHALL MOTOROLA BE LIABLE, WHETHER IN CONTRACT OR TORT (INCLUDING NEGLIGENCE) FOR DAMAGES IN EXCESS OF THE PURCHASE PRICE OF THE PRODUCT, ACCESSORY OR SOFTWARE, OR FOR ANY INDIRECT, INCIDENTAL, SPECIAL OR CONSEQUENTIAL DAMAGES OF ANY KIND, OR LOSS OF REVENUE OR PROFITS, LOSS OF BUSINESS, LOSS OF INFORMATION OR DATA, SOFTWARE OR APPLICATIONS OR OTHER FINANCIAL LOSS ARISING OUT OF OR IN CONNECTION WITH THE ABILITY OR INABILITY TO USE THE PRODUCTS, ACCESSORIES OR

SOFTWARE TO THE FULL EXTENT THESE DAMAGES MAY BE DISCLAIMED BY LAW.

Some states and jurisdictions do not allow the limitation or exclusion of incidental or consequential damages, or limitation on the length of an implied warranty, so the above limitations or exclusions may not apply to you. This warranty gives you specific legal rights, and you may also have other rights that vary from state to state or from one jurisdiction to another.

Laws in the United States and other countries preserve for Motorola certain exclusive rights for copyrighted Motorola software such as the exclusive rights to reproduce and distribute copies of the Motorola software. Motorola software may only be copied into, used in, and redistributed with, the Products associated with such Motorola software. No other use, including without limitation disassembly of such Motorola software or exercise of the exclusive rights reserved for Motorola, is permitted.

Patent and Software Provisions

MOTOROLA will defend, at its own expense, any suit brought against the end user purchaser to the extent that it is based on a claim that the Product or parts infringe a United States patent, and Motorola will pay those costs and damages finally awarded against the end user purchaser in any such suit which are attributable to any such claim, but such defense and payments are conditioned on the following:

- a. That MOTOROLA will be notified promptly in writing by such purchaser of any notice of such claim;
- b. That MOTOROLA will have sole control of the defense of such suit and all negotiations for its settlement or compromise; and
- c. Should the Product or parts become, or in MOTOROLA'S opinion be likely to become, the subject of a claim of infringement of a United States patent, that such purchaser will permit MOTOROLA, at its option and expense, either to procure for such purchaser the right to continue using the Product or parts or to replace or modify the same so that it becomes non-infringing or to grant such purchaser a credit for the Product or parts as depreciated and accept its return. The depreciation will be an equal amount per year over the lifetime of the Product or parts as established by MOTOROLA.

MOTOROLA will have no liability with respect to any claim of patent infringement which is based upon the combination of the Product or parts furnished hereunder with software, apparatus or devices not furnished by MOTOROLA, nor will MOTOROLA have any liability for the use of ancillary equipment or software not furnished by MOTOROLA which is attached to or used in connection with the Product or any parts thereof.

Laws in the United States and other countries preserve for MOTOROLA certain exclusive rights for copyrighted MOTOROLA software, such as the exclusive rights to reproduce in copies and

distribute copies of such MOTOROLA software. MOTOROLA software may be used in only the Product in which the software was originally embodied and such software in such Product may not be replaced, copied, distributed, modified in any way, or used to produce any derivative thereof. No other use including, without limitation, alteration, modification, reproduction, distribution, or reverse engineering of such MOTOROLA software or exercise or rights in such MOTOROLA software is permitted. No license is granted by implication, estoppel or otherwise under MOTOROLA patent rights or copyrights.

Hearing Aid Compatibility

A number of Motorola phones have been tested for hearing aid compatibility. When some wireless phones are used with certain hearing aids, users may detect a noise which can interfere with the effectiveness of the hearing aid.

Some hearing aids are more “immune” than others to this interference noise, and phones can also vary in the amount of interference noise they may generate. ANSI standard C63.19 was developed to provide a standardized means of measuring both mobile phone and hearing aids to determine usability rating categories for both.

Ratings have been developed for mobile phones to assist hearing aid users find phones that may be compatible with their hearing aid. Not all phones have been rated for compatibility with hearing aids. Phones that have been rated have a label with the rating(s) located on the box, and at www.motorola.com/iden.

These ratings are not guarantees of compatibility. Results will vary depending on the user’s hearing aid and individual type and degree of hearing loss. If a hearing aid is particularly vulnerable to interference, even a phone with a higher rating may still cause unacceptable noise levels in the hearing aid. Trying out the phone with your hearing aid is the best way to evaluate it for your personal needs.

“M” Rating: Phones rated M3 or M4 meet FCC requirements for hearing aid compatibility and are likely to generate less interference to hearing aids than unrated phones. (M4 is the “better” or higher of the two ratings.) On those models with an extendable antenna, this rating is determined only with the antenna extended.

“T” Rating: Phones rated T3 or T4 meet FCC requirements and are likely to be more usable with a hearing aid’s telecoil (“T Switch” or “Telephone Switch”) than unrated phones. (T4 is the “better” or higher of the two ratings.) On those models with a telecoil mode setting, this rating is determined only with the phone so set. For setting instructions, see “Features for the Hearing Impaired” in the section entitled “Advanced Calling Features”. Note that not all hearing aids have telecoils in them.

Hearing aids may also be measured for immunity to interference from wireless phones and may have ratings similar to wireless phones. Ask your hearing healthcare professional for the rating of your hearing aid. Add the rating of your hearing aid and your phone to determine the estimated usability:

- Any combined rating equal to or greater than six offers excellent use.
- Any combined rating equal to five is considered normal use.

- Any combined rating equal to four is considered usable.

Thus, if you use an M3 phone with a M3 hearing aid you will have a combined rating of six for “excellent use.” This methodology applies equally for T ratings.

More information about hearing aid compatibility may be found at:

www.motorola.com/accessibility, www.fcc.gov,
www.fda.gov, and
www.hearingloss.org/learn/cellphonetech.asp

Information From the World Health Organization

Present scientific information does not indicate the need for any special precautions for the use of mobile phones. If you are concerned, you may want to limit your own or your children's RF exposure by limiting the length of calls or by using

hands-free devices to keep mobile phones away from your head and body.

Source: WHO Fact Sheet 193

Further information: <http://www.who.int./peh-emf>

Product Registration

Online Product Registration:

<http://direct.motorola.com/hellomoto/Motosupport/source/registration.asp>

Product registration is an important step toward enjoying your new Motorola product. Registering helps us facilitate warranty service, and permits us to contact you should your product require an update or other service. Registration is for U.S.

residents only and is not required for warranty coverage.

Please retain your original dated sales receipt for your records. For warranty service of your Motorola Personal Communications Product you will need to provide a copy of your dated sales receipt to confirm warranty status.

Thank you for choosing a Motorola product.

Export Law Assurances

This product is controlled under the export regulations of the United States of America and Canada. The Governments of the United States of America and Canada may restrict the exportation or re-exportation of this product to certain destinations. For further information contact the

U.S. Department of Commerce or the Canadian Department of Foreign Affairs and International Trade.

Wireless: The New Recyclable

Your wireless mobile device can be recycled. Recycling your mobile device reduces the amount of waste disposed in landfills and allows recycled materials to be incorporated into new products.

The Cellular Telecommunications Industry Association (CTIA) and its members encourage consumers to recycle their mobile devices and have taken steps to promote the collection and environmentally sound recycling of end-of-life devices.

As a mobile device user, you have an important role in ensuring that this device is recycled properly. When it comes time to give this mobile device up or trade it in for a new one, please remember that the mobile device, the charger, and many of its accessories can be recycled. It's easy. To learn more about CTIA's Recycling Program for Used Wireless Devices, please visit us at:

<http://recycling.motorola.young-america.com/index.html>

California Perchlorate Label

Some mobile phones use an internal, permanent backup battery on the printed circuit board that may contain very small amounts of perchlorate. In such cases, California law requires the following label:

“Perchlorate Material - special handling may apply. See www.dtsc.ca.gov/hazardouswaste/perchlorate.”

There is no special handling required by consumer.

Privacy and Data Security

Motorola understands that privacy and data security are important to everyone. Because some features of your mobile device may affect your privacy or data security, please follow these recommendations to enhance protection of your information:

- **Monitor access** — Keep your mobile device with you and do not leave it where others may have unmonitored access. Lock your device's keypad where this feature is available.
- **Keep software up to date** — If Motorola or a software/application vendor releases a patch or software fix for your mobile device which updates the device's security, install it as soon as possible.
- **Erase before recycling** — Delete personal information or data from your mobile device prior to disposing of it or turning it in for recycling. For step-by-step instructions on how to delete all personal information from your device, see the section entitled "master clear" or "delete data" in this user's guide.

Note: For information on backing up your mobile device data before erasing it, go to www.motorola.com and then navigate to the "downloads" section of the consumer Web page

for "Motorola Backup" or "Motorola Phone Tools."

- **Understanding AGPS** — In order to comply with emergency caller location requirements of the FCC, certain Motorola mobile devices incorporate Assisted Global Positioning System (AGPS) technology. AGPS technology also can be used in non-emergency applications to track and monitor a user's location—for example, to provide driving directions. Users who prefer not to permit such tracking and monitoring should avoid using such applications.

If you have further questions regarding how use of your mobile device may impact your privacy or data security, please contact Motorola at privacy@motorola.com, or contact your service provider.

Smart Practices While Driving

Drive Safe, Call Smart SM

Check the laws and regulations on the use of mobile devices and their accessories in the areas where you drive. Always obey them. The use of these devices may be prohibited or restricted in certain areas. Go to www.motorola.com/callsmart for more information.

Your mobile device lets you communicate by voice and data—almost anywhere, anytime, wherever wireless service is available and safe conditions allow. When driving a car, driving is your first responsibility. If you choose to use your mobile device while driving, remember the following tips:

- **Get to know your Motorola mobile device and its features such as speed dial and redial.** If available, these features help you to place your call without taking your attention off the road.
- **When available, use a hands-free device.** If possible, add an additional layer of convenience to your mobile device with one of the many Motorola Original hands-free accessories available today.
- **Position your mobile device within easy reach.** Be able to access your mobile device without removing your eyes from the road. If you receive an incoming call at



an inconvenient time, if possible, let your voice mail answer it for you.

- **Let the person you are speaking with know you are driving; if necessary, suspend the call in heavy traffic or hazardous weather conditions.** Rain, sleet, snow, ice, and even heavy traffic can be hazardous.
- **Do not take notes or look up phone numbers while driving.** Jotting down a “to do” list or going through your address book takes attention away from your primary responsibility—driving safely.
- **Dial sensibly and assess the traffic; if possible, place calls when your car is not moving or before pulling into traffic.** If you must make a call while moving, dial only a few numbers, check the road and your mirrors, then continue.
- **Do not engage in stressful or emotional conversations that may be distracting.** Make people you are talking with aware you are driving and suspend conversations that can divert your attention away from the road.
- **Use your mobile device to call for help.** Dial 911 or other local emergency number in the case of fire, traffic accident, or medical emergencies.*

- **Use your mobile device to help others in emergencies.** If you see an auto accident, crime in progress, or other serious emergency where lives are in danger, call 911 or other local emergency number, as you would want others to do for you.*
- **Call roadside assistance or a special non-emergency wireless assistance number when necessary.** If you see a broken-down vehicle posing no serious hazard, a broken traffic signal, a minor traffic accident where no one appears injured, or a vehicle you know to be stolen, call roadside assistance or other special non-emergency wireless number.*

* Wherever wireless phone service is available.

Index

A

- accessories 13, 65, 81
- active phone line 59
- advanced calling 77
- alert
 - set 62, 67
 - turn off 62
- answer a call 20
- Audio formats 29
- auto replies 46

B

- backlight 69, 82
- battery 15, 17, 18
 - life, extend 15
- battery indicator 60
- Bluetooth
 - connect 54
 - send information 56
 - setting your phone 54
 - turning on or off 54

bluetooth 54

C

- call
 - answer 20
 - end 20
 - make 20
- call forward 73
- caller ID 72
- calls 71
- camera 30
 - media center 30
 - self-timer 31
- center key 63
- center select key 13
- clock 82
- codes 63
- combined power/end/home key 19, 20
- contacts 78

D

- datebook 78
 - receive events via WT 79
 - setup 69
- dial a phone number 20
- diald calls 71
- display 59
- Drafts 26

E

- earpiece volume 62
- emergency number 73
- end a call 20
- export regulations 100

F

- frequently asked questions
 - service and repairs 92

G

- Getting Started 1
 - Boost Customer Care 2
 - Instant Re-Boost 2
 - Introduction 1

Re-Boost 1

GPS 79

GPS enabled

emergency calls 74

GPS, see GPS enabled

H

- handsfree 81
- handsfree speaker 63
- Hearing Aid Compatibility 98
- home screen 59

I

- Image formats 29
- incoming call message 72
- international calls 74
- iTAP text entry mode 61

K

- keypad
 - locking 63

L

language 82
lock
 phone 63
low battery message 60

M

make a call 20
media center 29
Memory
 text messages 27
Message center
 text messages 25
message indicator 60
messages 82
MMS 38

N

navigation key 13, 63

O

one touch WT 37
optional accessory 13, 81
optional feature 13

P

packet data 60
PC applications 82
personalize 82
phone
 locking 63
phone number 23
private calls
 answer 21
 make 21

Q

Quick Notes 24
Quick WT 38

R

radio frequency 86
received calls 71
recent calls 71
recycling 101
redial 72
ring style indicator 60
ring style, setting 62
ring tones
 vibrate 67, 68

ringer volume 62

ringtones

off 67

setting 67

vibrate 67

S

safety

radio frequency 86

RF energy interference 89

safety information 86

safety tips 104

security 84

send key 20

SIM card 14

change SIM PIN 84

enable SIM PIN 84

soft keys 59

speaker 59, 79

speed dial 74

store your number 23

T

tap text entry mode 61

text entry 60

text messages 23

creating 25

deleting 27

drafts 26

memory 27

message center 25

receiving 25

resend messages 26

sending 25

sent messages 27

setting up 23

transmitters 63

TTY calls 83

turn on/off 19

U

unlock

phone 63

unlock code 63

V

voice mail 75

receiving 75

setting up 75

voice names 72

volume 62

W

wallpaper 68

WHO information 100

WT 32

WT service 38

Y

your phone number 23