

MB87 870 MHz Amplifier

STARLINE[®] Series



Motorola's STARLINE[®] series amplifier, model MB87*/*, leads the industry in features and performance and is designed to meet the needs of today's expanding broadband communication networks. This two-way capable dual output amplifier offers high gain, high output levels, ergonomics, superior distortion performance, four diplex filter options, 15 dB return loss, and Bode equalization. The MB87*/* also allows optional advanced features such as ingress control switching and status monitoring. A third output is user-configurable via splitter or directional coupler plug-in. Single output models are also available.

The MB87 two-way amplifier offers 870 MHz bandwidth capability, high gain, high output level, ergonomics, and superior distortion performance.

ENHANCED GALLIUM ARSENIIDE

The MB87 uses Enhanced Gallium Arsenide (E-GaAs) hybrids. This second generation technology provides superior distortion performance in CTB and CSO over the standard GaAs technology. Compared to silicon and competing GaAs technology, E-GaAs distortion performance remains linear at significantly higher output levels. This higher output level allows the customer to maximize system performance and reduce system costs. We encourage our customers to contact their Motorola Account Representative to determine the optimal levels for their systems.

HIGH GAIN

The MB87 also offers high gain. This allows the operator to hold existing amplifier locations during system upgrades thereby reducing system costs.

BENEFITS INCLUDE:

- 870 MHz Enhanced Gallium Arsenide (E-GaAs) power doubling technology
- High gain
- High output level
- Four diplex filter options
- Ease-of-use ergonomics
- 15 dB return loss
- 60/90 V powering
- Meets Telcordia GR-1098-Core voltage surge requirements using surge waveforms as described in IEEE C62.41
- FCC, CENELEC and CCC approved
- Bode equalization (thermal or auto controlled)
- 15 ampere AC capability
- Optional return path ingress control and status monitor
- Power factor corrected power supply
- Directional coupler -20 dB test points



Motorola, Inc.
Connected Home Solutions
101 Tournament Drive
Horsham, PA 19044
1.800.523.6678
www.motorola.com/broadband

Rev. 1.0
09.01.05



MOTOROLA and the Stylized M Logo are registered in the US Patent & Trademark Office.
All other product or service names are the property of their respective owners.
© Motorola, Inc. 2003

Specifications are subject to change without notice.

BACKWARD COMPATIBILITY

The MB87 electronics package can be made backward compatible with the 10-Amp MB*/* housing by installing the MB-15A Kit or the MB-15A Kit II. These kits contain 50 mil gold plated platform assemblies. This makes it possible for the amplifier to carry 15 Amperes continuous through the input or output ports.

FORWARD PATH

The operational gain of the MB87 is 34 dB or 40 dB depending on model, with 15 dB return loss. Output level control is achieved through the use of an interstage Bode equalizer, which compensates for coaxial cable attenuation changes due to temperature. Equalization may be controlled manually, with a thermal drive unit (model TDU) or with a single pilot closed loop automatic drive unit (model ADU-* or QADU). Both the TDU and the ADU boards are common to the STARLINE family of amplifiers (with the exception of the SLE). ADUs utilize Surface Acoustic Wave (SAW) filters for determining pilot frequency. This improves amplifier stability over temperature.

To further ensure system flexibility, installation ease and maintenance, the amplifier is engineered for compatibility with standard accessories, such as attenuators, equalizers, ADUs or TDUs, return amplifiers, automotive fuses and FTEC - BTA crowbar circuits.

For an optional third output, the MB87 utilizes splitters (model SP) and directional couplers (model DC/*). The SP, DC/8, DC/10, and DC/12 offer superior performance to 1 GHz.

The MB87 uses modular diplex filters, which can be changed for a different frequency split as required. The amplifier is available with S-split filters for a 5-40 MHz return and a 52-870 MHz forward band. K-splits (5-42 MHz/54-870 MHz), J-splits (5-55 MHz/70-870 MHz), and A-splits (5-65 MHz/85-870 MHz) are also available. These same filters can be used for all US-style Motorola RF distribution amplifiers (models BLE, MB/MBE, BT).

RETURN PATH

High gain return amplifier kits can be ordered which provide 20 dB minimum station gain. Return path equalizers from 0 to 12 dB can be customer selected. Optional features include thermal compensation and ingress control switching. Thermal compensation comes in the form of a plug-in JXP-TH*C, which stabilizes gain and match over temperature extremes.

Also available is Ingress Control Switching (ICS) in 3 states. This pin diode attenuator circuit can lower levels by 6 dB or by 38 dB with a controlled slew rate for minimum bit errors. The dual output MB*/* requires two ingress control switches when ordering this option (one ICS required for each output). The LIFELINE® MiniBridger Amplifier transponder, model LL-MB-HMS-*/*, is required to operate the Ingress Control Switch from a remote location.

Model Availability

To reduce customer costs and to accommodate customer specific needs, the STARLINE MB87 can be ordered in a variety of different models. *Please refer to the MB87 ordering information below for options.*



MB87 Specifications

STARLINE®

2 Port, Parallel E-GaAs Hybrid

**Enhanced Gallium Arsenide
MiniBridger Amplifier**

MB87S/XG* Specifications

PARAMETER	UNITS NOTE		FORWARD	RETURN RA-KIT-40H
Passband	MHz	1	52-870	5-40
Flatness	dB	2	± 0.70	± 0.50
Minimum Full Gain	dB	3	45	NA
Operational Gain	dB	4	40	20
Manual Bode Slope Control Range	dB	5	± 5	NA
Interstage Equalizer Slope	dB	6	12 ±1	NA
Noise Figure 40/52/870MHz	dB	7	NA / 12 / 10	9 / NA / NA
Reference Frequency	MHz	8	870 / 550 / 52	40
Output Level	dBmV		43 / 44 / 37	41 FLAT
Channel Loading	NTSC		79	4
Compressed data loading	MHz		320	NA
Distortion (max)	CTB	dBc 9,21,23	75	NA
	XM	dB 10,21	65	69
	CSO	dBc 9,11,21	71	NA
	CCN (-6)	dBc 12	54	NA
	STB	dBc 9	NA	78
	SSO	dBc 9	NA	76
Test Point (all)	dB	13	20 ±1.0	
Return Loss	dB	14	15	
Hum Modulation	dBc	15,20	65	
DC Voltage	VDC	16	+ 24.0 ± 0.25	
Current DC	mA	17	1475	1610
DC Ripple	mV		15 P-P	
Power Consumption	W		44.0	48
AC Input Voltage Range	VAC		38 - 90	
AC Current Draw	@90 VAC	A 18	0.51	0.55
	@75 VAC	A	0.62	0.68
	@60 VAC	A	0.74	0.81
	@53 VAC	A	0.85	0.92
	@45 VAC	A	0.95	1.08
	@38 VAC	A	1.2	1.31
AC Bypass Current	All Ports	A 18	15	
Group Delay (max)		19		
	55.25 to 58.83 MHz	nSec	30	NA
	5.0 to 6.5 MHz	nSec	NA	45
	10.0 to 11.5 MHz	nSec	NA	10
	33.5 to 35.0 MHz	nSec	NA	12
	38.5 to 40.0 MHz	nSec	NA	35
Housing Dimensions			15.4"L x 5.5"W x 9.6"D	39.1cm x 13.97cm x 24.3 cm
Weight			15 Pounds	6.8 kg
Ambient Operating Temperature			-40° to +140° F	-40° to +60° C



STARLINE®

2 Port, Parallel E-GaAs Hybrid

Enhanced Gallium Arsenide
MiniBridger Amplifier

MB87S/XG* Specifications with low gain option P

PARAMETER		UNITS NOTE		FORWARD	RETURN RA-KIT-40H
Passband		MHz	1	52-870	5-40
Flatness		dB	2	± 0.60	± 0.50
Minimum Full Gain		dB	3	39	NA
Operational Gain		dB	4	34	20
Manual Bode Slope Control Range		dB	5	± 5	NA
Interstage Equalizer Slope		dB	6	12 ±1	NA
Noise Figure	40 / 52 / 870MHz	dB	7	NA / 12 / 10	9 / NA / NA
Reference Frequency		MHz	8	870 / 550 / 52	40
Output Level		dBmV		43 / 44 / 37	41 FLAT
Channel Loading		NTSC		79	4
Compressed data loading		MHz		320	NA
Distortion (max)	CTB	dBc	9,21,23	75	NA
	XM	dB	10,21	65	69
	CSO	dBc	9,11,21	75	NA
	CCN (-6)	dBc	12	54	NA
	STB	dBc	9	NA	78
	SSO	dBc	9	NA	76
Test Point (all)		dB	13	20 ±1.0	
Return Loss		dB	14	15	
Hum Modulation		dBc	15,20	65	
DC Voltage		VDC	16	+ 24.0 ± 0.25	
Current DC		mA	17	1475	1610
DC Ripple		mV		15 P-P	
Power Consumption		W		44	48
AC Input Voltage Range		VAC		38 - 90	
AC Current Draw	@90 VAC	A	18	0.51	0.55
	@75 VAC	A		0.62	0.68
	@60 VAC	A		0.74	0.81
	@53 VAC	A		0.85	0.92
	@45 VAC	A		0.95	1.08
	@38 VAC	A		1.2	1.31
AC Bypass Current	All Ports	A	18	15	
Group Delay (max)	55.25 to 58.83 MHz	nSec	19	30	NA
	5.0 to 6.5 MHz	nSec		NA	45
	10.0 to 11.5 MHz	nSec		NA	10
	33.5 to 35.0 MHz	nSec		NA	12
	38.5 to 40.0 MHz	nSec		NA	35
Housing Dimensions				15.4"L x 5.5"W x 9.6"D	39.1cm x 13.97cm x 24.3 cm
Weight				15 Pounds	6.8 kg
Ambient Operating Temperature				-40° to +140° F	-40° to +60° C



STARLINE®

1 Port, Single E-GaAs Hybrid

Enhanced Gallium Arsenide
MiniBridger Amplifier

MB87S/SG* Specifications

PARAMETER		UNITS	NOTE	FORWARD	RETURN RA-KIT-40H
Passband		MHz	1	52-870	5-40
Flatness		dB	2	± 0.70	± 0.50
Minimum Full Gain		dB	3	45	NA
Operational Gain		dB	4	40	20
Manual Bode Slope Control Range		dB	5	± 5	NA
Interstage Equalizer Slope		dB	6	12 ±1	NA
Noise Figure 40/52/870MHz		dB	7	NA / 13 / 11	9.5 / NA / NA
Reference Frequency		MHz	8	870 / 550 / 52	40
Output Level		dBmV		43 / 44 / 37	41 FLAT
Channel Loading		NTSC		79	4
Compressed data loading		MHz		320	NA
Distortion (max)	CTB	dBc	9,21,23	75	NA
	XM	dB	10,21	65	69
	CSO	dBc	9,11,21	71	NA
	CCN (-6)	dBc	12	54	NA
	STB	dBc	9	NA	78
	SSO	dBc	9	NA	76
Test Point (all)		dB	13	20 ±1.0	
Return Loss		dB	14	15	
Hum Modulation		dBc	15,20	65	
DC Voltage		VDC	16	+ 24.0 ± 0.25	
Current DC		mA	17	1475	1610
DC Ripple		mV		15 P-P	
Power Consumption		W		44.0	48
AC Input Voltage Range		VAC		38 - 90	
AC Current Draw	@90 VAC	A	18	0.34	0.39
	@75 VAC	A		0.42	0.48
	@60 VAC	A		0.51	0.57
	@53 VAC	A		0.57	0.65
	@45 VAC	A		0.67	0.75
	@38 VAC	A		0.82	0.93
AC Bypass Current	All Ports	A	18	15	
Group Delay (max)	55.25 to 58.83 MHz	nSec	19	30	NA
	5.0 to 6.5 MHz	nSec		NA	45
	10.0 to 11.5 MHz	nSec		NA	10
	33.5 to 35.0 MHz	nSec		NA	12
	38.5 to 40.0 MHz	nSec		NA	35
Housing Dimensions				15.4"L x 5.5"W x 9.6"D	39.1cm x 13.97cm x 24.3 cm
Weight				15 Pounds	6.8 kg
Ambient Operating Temperature				-40° to +140° F	-40° to +60° C



STARLINE®

1 Port, Single E-GaAs Hybrid

Enhanced Gallium Arsenide
MiniBridger Amplifier

MB87S/SG* Specifications with low gain option P

PARAMETER				UNITS	NOTE	FORWARD	RETURN RA-KIT-40H
Passband		MHz	1		52-870	5-40	
Flatness		dB	2		± 0.70	± 0.50	
Minimum Full Gain		dB	3		39	NA	
Operational Gain		dB	4		34	20	
Manual Bode Slope Control Range		dB	5		± 5	NA	
Interstage Equalizer Slope		dB	6		12 ±1	NA	
Noise Figure 40/52/870MHz		dB	7		NA / 13 / 11	9.5 / NA / NA	
Reference Frequency		MHz	8		870 / 550 / 52	40	
Output Level		dBmV			43 / 44 / 37	41 FLAT	
Channel Loading		NTSC			79	4	
Compressed data loading		MHz			320	NA	
Distortion (max)	CTB	dBc	9,21,23		75	NA	
	XM	dB	10,21		65	69	
	CSO	dBc	9,11,21		75	NA	
	CCN (-6)	dBc	12		54	NA	
	STB	dBc	9		NA	78	
	SSO	dBc	9		NA	76	
Test Point (all)		dB	13		20 ±1.0		
Return Loss (min)		dB	14		15		
Hum Modulation		dBc	15,20		65		
DC Voltage		VDC	16		+ 24.0 ± 0.25		
Current DC		mA	17		1475	1610	
DC Ripple		mV			15 P-P		
Power Consumption		W			44	48	
AC Input Voltage Range		VAC			38 - 90		
AC Current Draw	@90 VAC	A	18		0.34	0.39	
	@75 VAC	A			0.42	0.48	
	@60 VAC	A			0.51	0.57	
	@53 VAC	A			0.57	0.65	
	@45 VAC	A			0.67	0.75	
	@38 VAC	A			0.82	0.93	
AC Bypass Current	All Ports	A	18		15		
Group Delay (max)	55.25 to 58.83 MHz	nSec	19		30	NA	
	5.0 to 6.5 MHz	nSec			NA	45	
	10.0 to 11.5 MHz	nSec			NA	10	
	33.5 to 35.0 MHz	nSec			NA	12	
	38.5 to 40.0 MHz	nSec			NA	35	
Housing Dimensions					15.4"L x 5.5"W x 9.6"D	39.1cm x 13.97cm x 24.3 cm	
Weight					15 Pounds	6.8 kg	
Ambient Operating Temperature					-40° to +140° F	-40° to +60° C	



Notes:

1. Operating passband of station. Diplex filters are plugged into the electronic chassis.
2. Referenced to the average gain across the stated passband.
3. Minimum full gain at 870 MHz includes loss of equalizer but Bode slope reserves have not been set. Return gain includes loss of SRE -4 return equalizer.
4. Operational gain includes loss of slope reserves as well as equalizer.
5. Amount of Bode slope control range from midpoint (typical setting is -4 dB at 870 MHz @ 20°C). This control should not be used for gain reduction.
6. Amount of slope created and cable equivalence of fixed interstage equalizer. Interstage equalizer is a plug-in.
7. Noise Figure performance is specified typical. Noise Figure is specified at the cable entry facility of the housing and includes the loss of 1 dB for the pre-stage equalizer. The return Noise Figure includes the station loss preceding the RF hybrid.
8. Frequencies that relate the picture carriers or passband edges to the specified output levels and tilts.
9. Measured with CW carriers and spectrum analyzer over specified temperature range. References the worst-case channel. Specifications are compliant with the test methods as stated in NCTA RECOMMENDED PRACTICES FOR MEASUREMENTS ON CABLE TELEVISION SYSTEMS.
10. Measured with wave analyzer and synchronous, 100% depth modulated channels. References the worst-case channels over specified temperature range. Specifications are compliant with the test methods as stated in NCTA RECOMMENDED PRACTICES FOR MEASUREMENTS ON CABLE TELEVISION SYSTEMS.
11. Composite Second Order distortion refers only to those beat clusters that fall $+0.75$ MHz and $+1.25$ MHz above the subject picture carrier. CSO beat clusters that have a -0.75 MHz and -1.25 MHz relationship to the subject picture carrier are not included in this specification.
12. CCN (Composite, Carrier-to-Noise Ratio) is a 10 log addition of both the Carrier-to-Noise Ratio (CNR) and Carrier-to-Intermodulation Noise Ratio (CIN).
13. Test points should be used with GFAL adaptor.
14. Match measurement at the station input and output, cable-entry facilities, at the specified passbands for operational gain.
15. Measured with the stated AC Bypass Current.
16. Measured at the power connector.
17. Current draw at $+24.0$ VDC.
18. AC current is stated in RMS continuous.
19. Group Delay is specified for standard NTSC video, where delay is the delta from picture carrier to 3.58 MHz color subcarrier. Reverse delay is in a 1.5 MHz bandwidth.
20. Hum Modulation performance is stated typical. Return band specified from 15 MHz. Hum Modulation (5 MHz to 15 MHz) is -55 dBc.
21. Distortion numbers are worst case over temperature in a cascade.
22. The compressed data loading is QAM carriers and are -6 dB relative to the analog CW carriers.
23. CTB (Composite Triple Beat). At the specified channel loading, Enhanced Gallium Arsenide performance varies on a two point three-for-one (2.3:1) basis with amplifier output level.



MB87 Block Diagram

Dual Output

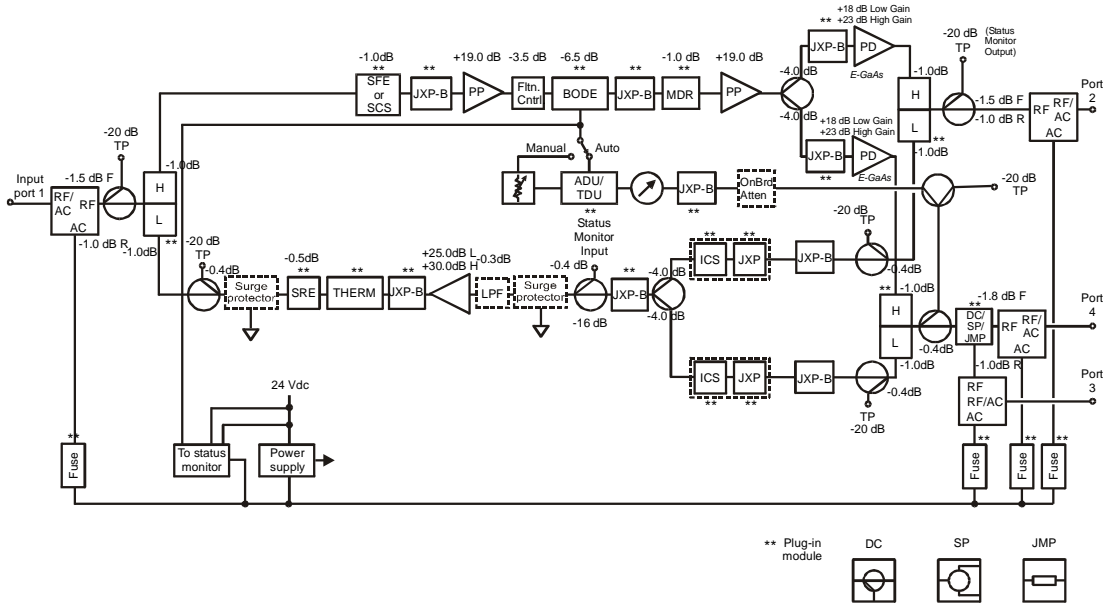

Single Output

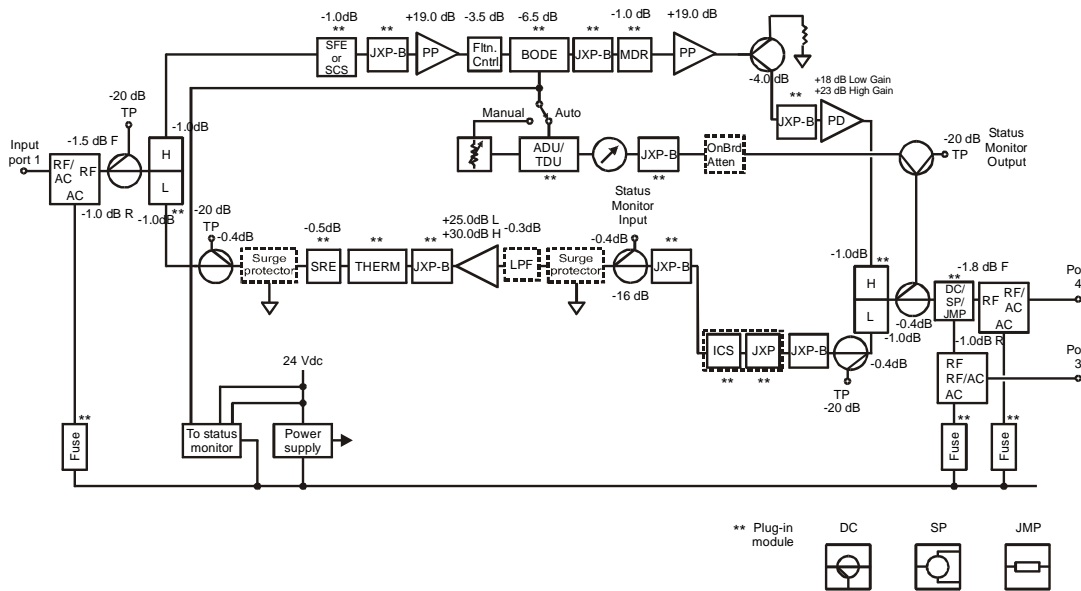

MB87 Ordering Information

Model	Description	Motorola Part Number	Qty per MB
STANDARD MB MODELS			
S-SPLIT			
MB87S/XGXX-HXX-XXX-XC-XXX-XXX-E	5-40 / 52-870 MHz split, two-output, E-GaAs, manual gain control, 12 dB internal slope, high gain return, 40 dB high gain forward, 20A fuses, FTEC, full station	795005-047-00	
MB87S/XGAX-HXX-XXX-XC-XXX-XXX-E	5-40 / 52-870 MHz split, two-output, E-GaAs, ADU 499.25 MHz gain control, 12 dB internal slope, high gain return, 40 dB high gain forward, 20A fuses, FTEC, full station	795005-002-00	
MB87S/XGTX-HXX-XXX-XC-XXX-XXX-E	5-40 / 52-870 MHz split, two-output, E-GaAs, TDU gain control, 12 dB internal slope, high gain return, 40 dB high gain forward, 20A fuses, FTEC, full station	795005-043-00	
MB87S/XGXX-HXX-XPX-XC-XXX-XXX-E	5-40 / 52-870 MHz split, two-output, E-GaAs, manual gain control, 12 dB internal slope, high gain return, 34 dB low gain forward, 20A fuses, FTEC, full station	795005-116-00	
MB87S/XGAX-HXX-XPX-XC-XXX-XXX-E	5-40 / 52-870 MHz split, two-output, E-GaAs, ADU 499.25 MHz gain control, 12 dB internal slope, high gain return, 34 dB low gain forward, 20A fuses, FTEC, full station	795005-072-00	
MB87S/XGTX-HXX-XPX-XC-XXX-XXX-E	5-40 / 52-870 MHz split, two-output, E-GaAs, TDU gain control, 12 dB internal slope, high gain return, 34 dB low gain forward, 20A fuses, FTEC, full station	795005-250-00	
MB87S/XGXX-HXX-XXX-XX-XXX-XXX-E	5-40 / 52-870 MHz split, two-output, E-GaAs, manual gain control, 12 dB internal slope, high gain return, 40 dB high gain forward, 20A fuses, standard surge arrestor, full station	795005-051-00	
K-SPLIT			
MB87K/XGXX-HXX-XXX-XC-XXX-XXX-E	5-42 / 54-870 MHz split, two-output, E-GaAs, manual gain control, 12 dB internal slope, high gain return, 40 dB high gain forward, 20A fuses, FTEC, full station	795005-284-00	
MB87K/XGXX-HXX-XXX-XX-XXX-XXX-E	5-42 / 54-870 MHz split, two-output, E-GaAs, manual gain control, 12 dB internal slope, high gain return, 40 dB high gain forward, 20A fuses, standard surge arrestor, full station	795005-054-00	
MB87K/XGAX-HXX-XXX-XC-XXX-XXX-E	5-42 / 54-870 MHz split, two-output, E-GaAs, ADU 499.25 MHz gain control, 12 dB internal slope, high gain return, 40 dB high gain forward, 20A fuses, FTEC, full station	795005-243-00	
MB87K/XGXX-HXX-XPX-XC-XXX-XXX-E	5-42 / 54-870 MHz split, two-output, E-GaAs, manual gain control, 12 dB internal slope, high gain return, 34 dB low gain forward, 20A fuses, FTEC, full station	795005-088-00	
A-SPLIT			
MB87A/XGXX-HXX-XXX-XX-XXX-XXX-E	5-65 / 85-870 MHz split, two-output, E-GaAs, manual gain control, 12 dB internal slope, high gain return, 40 dB high gain forward, 20A fuses, standard surge arrestor, full station	795005-034-00	
J-SPLIT			
MB87J/XGTX-HXX-XXX-XC-XXX-XXX-E	5-55 / 70-870 MHz split, two-output, E-GaAs, TDU gain control, 12 dB internal slope, high gain return, 40 dB high gain forward, 20A fuses, FTEC, full station	795005-293-00	



NON-STANDARD MB MODELS

MB87S/SGXX-HXX-XXX-XC-XXX-XXX-E	5-40 / 52-870 MHz split, one-output, E-GaAs, manual gain control, 12 dB internal slope, high gain return, 40 dB high gain forward, 20A fuses, FTEC, full station	795005-291-00	
MB87S/XGXX-HXX-XXX-XX-NXX-XXX-E	5-40 / 52-870 MHz split, two-output, E-GaAs, manual gain control, 12 dB internal slope, high gain return, 40 dB high gain forward, 20A fuses, 15 A electronics module only (no housing)	795005-287-00	
MB75S/XGXX-HXX-XXX-XC-XXX-XXX-E	5-40 / 52-750 MHz split, two-output, E-GaAs, manual gain control, 12 dB internal slope, high gain return, 40 dB high gain forward, 20A fuses, FTEC, full station	795005-199-00	
MB87K/SGXX-HXX-XXX-XC-XXX-XXX-E	5-42 / 54-870 MHz split, one-output, E-GaAs, manual gain control, 12 dB internal slope, high gain return, 40 dB high gain forward, 20A fuses, FTEC, full station	795005-310-00	
MB87K/XGXX-HXX-XXX-XX-NXX-XXX-E	5-42 / 54-870 MHz split, two-output, E-GaAs, manual gain control, 12 dB internal slope, high gain return, 40 dB high gain forward, 20A fuses, 15 A electronics module only (no housing)	795005-311-00	
MB87A/XGXX-HXX-XXX-XX-NXX-XXX-E	5-65 / 85-870 MHz split, two-output, E-GaAs, manual gain control, 12 dB internal slope, high gain return, 40 dB high gain forward, 20A fuses, standard surge arrester, 15 A electronics module only (no housing)	795005-312-00	
MB87J/XGXX-XXX-XXX-XX-XXX-XXX-E	5-55 / 70-870 MHz split, two-output, E-GaAs, manual gain control, 12 dB internal slope, no return, 40 dB high gain forward, 20A fuses, standard surge arrester, full station	795005-027-00	
Accessories			
SFE-0 or SFE-1 or SFE-87-* or SFE-75-* or SCS-*	Starline Forward Equalizer, 5 – 1 GHz, 0 dB Starline Forward Equalizer, 5 – 1 GHz, 1 dB Starline Forward 870 MHz equalizer (0 to 22 dB in 1 dB steps) Starline Forward 750 MHz equalizer (0 to 22 dB in 1 dB steps) Starline Cable Simulators	479309-001-00 479309-002-00 477725-* 477822-* 477888-*	1
SRE-**-*	Starline Return Equalizer, 5-40 MHz (S-split), 5-42 (K-split), 5-55 (J-split), 5-65 (A-split), values 0-12 dB in 1 dB steps for S-split (2 dB steps for all other frequency splits)	478176-*	1
JXP-*B	Plug-in attenuator/pad (values 0 to 26 dB, in 1 dB steps)	474011-*	9 (dual) 7 (single)
SP	Splitter	478657-001-00	1 (optional)
DC/8 DC/10 DC/12	Directional Coupler, 8 dB Directional Coupler, 10 dB Directional Coupler, 12 dB	478658-001-00 478658-002-00 478658-003-00	1 (optional)



MOTOROLA Standard MiniBridger Model Guide/Description

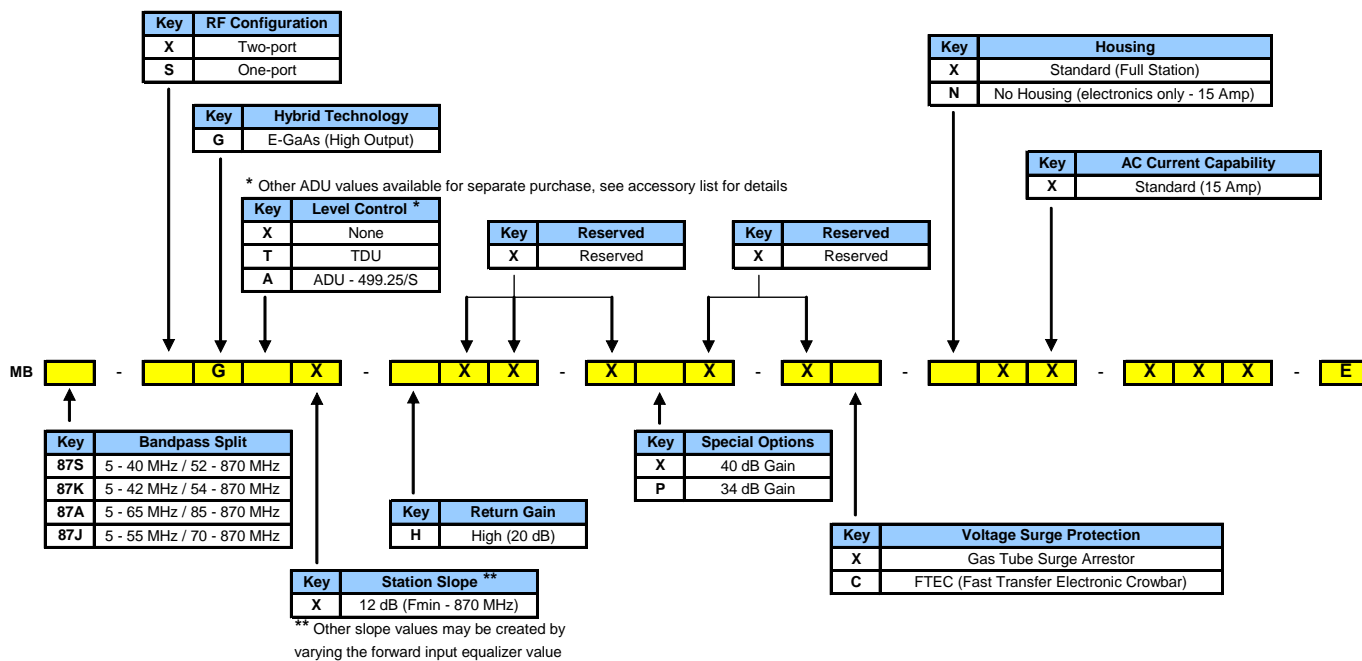

Other Accessories for MB87		
Model	P/N	Description
ADU-*	928129-*	Automatic drive unit
ADU-499.25/S	928129-017	Automatic drive unit - pilot at 499.25 MHz (uses SAW filter)
ADU-439.25/S	928129-018	Automatic drive unit - pilot at 439.25 MHz (uses SAW filter)
ADU-403.25/S	928129-019	Automatic drive unit - pilot at 403.25 MHz (uses SAW filter)
ADU-445.25/S	928129-020	Automatic drive unit - pilot at 445.25 MHz (uses SAW filter)
ADU-549.00/S	928129-010	Automatic drive unit - pilot at 549.00 MHz (uses SAW filter)
ADU-423.25	928129-023	Automatic drive unit - pilot at 423.25 MHz
ADU-498.00	928129-009	Automatic drive unit - pilot at 498.00 MHz
QADU-609.00/S	928129-026	QAM Automatic drive unit - QAM pilot at 609 MHz (uses SAW filter)
F/JXP-20	927714-001	Test probe
FTEC/BTA	928103-000	Fast transfer electronic crowbar surge protector (230V)
FTEC-145	928103-001	Fast transfer electronic crowbar surge protector (145V)
Fuses	928303-tab	Automotive style fuses
Shunts	928303-000	35A automotive style fuses
GFAL	927709-000	Test probe
ICS-II	454056-002	Ingress control switch for amplifiers
JXP-75T	927265-075	75 ohm terminator (short profile)
JXP-RC	927703-002	Forward path (full band) correction board
JXP-RPC	927703-003	Return path correction board (mid-band)
JXP-TH2C	479310-007	2 dB plug-in thermal pad used in return path (two-tier ergonomic)
JXP-TH3C	479310-008	3 dB plug-in thermal pad used in return path (two-tier ergonomic)
LL-MB-HMS-*/*	515883-*	Lifeline transponder for MB (HMS compliant)
MB 15A Kit	951941-005	For MB-550D-H or MB-750D-H upgrade to 15 amps
MB 15AII Kit	951941-007	For MB-75SH upgrade to 15 amps
MPPSII/CVR	484020-001	MB housing lid with MPPS-II (230Vac) power supply
MPPSII/HSG	482592-001	MB housing with MPPS-II (230Vac) power supply
MPPS-II/FJ	518530-001	Field jumper cable kit for MPPS-II to reduce power noise
RA-KIT/H	927810-007	Return path kit (high gain)
RA-KIT/L	927810-006	Return path kit (low gain)
TDU	928119-000	Thermal drive unit
SHP 815	447983-001	Return high pass filter (15 - 65 MHz)
SHP 815-II	447983-003	Return high pass filter (15 - 65 MHz) - smaller design
SHP 825	447983-002	Return high pass filter (25 - 65 MHz) - smaller design
SZW 852	516299-001	Diplex filter, 40/52 MHz S-split
SZW 854	478005-001	Diplex filter, 42/54 MHz K-split
SZW 885	440168-001	Diplex filter, 65/85 MHz A-split
SZW 870	516301-001	Diplex filter, 55/70 MHz J-split
SZW 847	447280-001	Diplex filter, 30/47 MHz E-split

