



---

*Installation Manual*

---

DCX3510-M

High-Definition DVR



©2011 Motorola Mobility, Inc. All rights reserved. No part of this publication may be reproduced in any form or by any means or used to make any derivative work (such as translation, transformation, or adaptation) without written permission from Motorola, Inc. Motorola reserves the right to revise this publication and to make changes in content from time to time without obligation on the part of Motorola to provide notification of such revision or change. Motorola provides this guide without warranty of any kind, implied or expressed, including, but not limited to, the implied warranties of merchantability and fitness for a particular purpose. Motorola may make improvements or changes in the product(s) described in this manual at any time.

MOTOROLA and the Stylized M logo are trademarks or registered trademarks of Motorola Trademark Holdings, LLC. OCAP™, CableCARD™, M-Card™, and DOCSIS® are trademarks or registered trademarks of Cable Television Laboratories, Inc. HDMI, the HDMI Logo and High-Definition Multimedia Interface are trademarks or registered trademarks of HDMI Licensing LLC. Dolby and the double-D symbol are registered trademarks of Dolby Laboratories. This product incorporates copyright protection technology that is protected by U.S. patents and other intellectual property rights. Use of this copyright protection technology must be authorized by Rovi, and is intended for home and other limited viewing uses only unless otherwise authorized by Rovi. Reverse engineering or disassembly is prohibited. All other product or service names are the property of their respective owners.. All other product or service names are the property of their respective owners.

© Copyright 2011 Multimedia over Coax Alliance. All Rights Reserved. MoCA and the MoCA logo is a trademark of Multimedia over Coax Alliance. The Multimedia over Coax Alliance (MoCA), [www.mocalliance.org](http://www.mocalliance.org), is an open, standard body promoting networking of digital video and entertainment through existing coaxial cable in the home.



# Safety & Regulatory Information

## IMPORTANT SAFETY INSTRUCTIONS

- Read these instructions.
- Keep these instructions.
- Heed all warnings.
- Follow all instructions.
- Do not use this apparatus near water.
- Clean only with dry cloth.
- Do not block any ventilation openings. Install in accordance with the manufacturer's instructions.
- Do not install near any heat sources such as radiators, heat registers, stoves, or other apparatus (including amplifiers) that produce heat.
- Do not defeat the safety purpose of the polarized or grounding type plug. A polarized plug has two blades with one wider than the other. A grounding type plug has two blades and a third grounding prong. The wide blade or the third prong is provided for your safety. If the provided plug does not fit into your outlet, consult an electrician for replacement of the obsolete outlet.
- Protect the power cord from being walked on or pinched particularly at plugs, convenience receptacles, and the point where they exit from the apparatus.
- Only use attachments/accessories specified by the manufacturer.
- Unplug this apparatus during lightning storms or when unused for long periods of time.
- Refer all servicing to qualified service personnel. Servicing is required when the apparatus has been damaged in any way, such as the power supply cord or plug is damaged, liquid has been spilled or objects have fallen into the apparatus, the apparatus has been exposed to rain or moisture, does not operate normally, or has been dropped.

## IMPORTANT SAFETY CONSIDERATIONS

The DCX3510-M set-top requires careful handling to avoid potential damage to its internal hard disk drive or the loss of recorded data. Be sure to follow these requirements during transportation and installation.

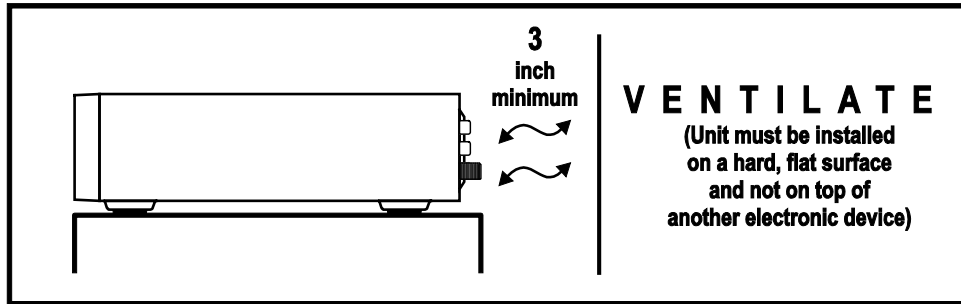
The plug is the main disconnect device. It shall remain readily accessible and operable.

The apparatus shall not be exposed to dripping or splashing and no objects filled with liquids, such as vases, shall be placed on the apparatus.

### During Transportation to the Subscriber Home

Transport the cable terminal in its shipping box or an equally padded container.

Do not expose the terminal to rain or moisture.



### During Installation

- Do not place the terminal in an enclosed area where the cooling vents are blocked or impede the flow of air through the ventilation openings.
- Install the terminal so that its position does not interfere with its proper ventilation. For example, do not place the terminal on a bed, sofa, rug, or similar surface that could block the ventilation openings.
- Install the terminal away from heat sources such as radiators, heat registers and stoves. Installation of the terminal near consumer electronics devices, such as stereo receiver/amplifiers and televisions, is permitted as long as the air surrounding the terminal does not exceed 40° C (104° F).
- Place the terminal on a flat surface not prone to vibration or impact.
- Do not install the terminal in an area where condensation occurs.
- To prevent the temporary loss of guide data and cause a temporarily non-responding terminal, do not plug the AC power cord into a switched power outlet.
- To avoid shock and vibration damage to the internal hard drive, do not move the terminal while it is plugged in.
- To allow the hard drive to spin down and park its heads, wait at least 10 seconds after disconnecting power before moving the terminal.

### FCC Compliance

Note: This equipment has been tested and found to comply with the limits for a Class B digital device, pursuant to part 15 of the FCC Rules. These limits are designed to provide reasonable protection against harmful interference in a residential installation. This equipment uses and can radiate radio frequency energy and, if not installed and used in accordance with the instructions, may cause harmful interference to radio communications. However, there is no guarantee that interference will not occur in a particular installation. If this equipment does cause harmful interference to radio or television reception, which can be determined by turning the equipment off and on, the user is encouraged to try to correct the interference by one or more of the following measures:

- Reorient or relocate the receiving antenna.
- Increase the separation between the equipment and set-top.
- Connect the equipment into an outlet on a circuit different from that to which the set-top is connected.
- Consult the dealer or an experienced radio/TV technician for help.

Caution: Changes or modifications not expressly approved by Motorola for compliance could void the user's authority to operate the equipment.

This device complies with part 15 of the FCC Rules. Operation is subject to the following two conditions: (1) This device may not cause harmful interference, and (2) this device must accept any interference received, including interference that may cause undesired operation.



## FCC Declaration Of Conformity

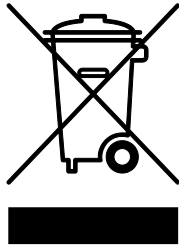
Motorola Mobility, 101 Tournament Drive, Horsham, PA 19044, 1-215-323-1000, declares that the DCX 3510 set-top complies with 47 CFR Parts 2 and 15 of the FCC rules as a Class B digital device.

## Canada Industry Canada (IC)

This Class B digital device complies with Canadian ICES-003.

Cet appareil numérique de la classe B est conforme à la norme NMB-003 du Canada.

## Caring for the Environment by Recycling



When you see this symbol on a Motorola product, do not dispose of the product with residential or commercial waste.

### Recycling your Motorola Equipment

Please do not dispose of this product with your residential or commercial waste. Some countries or regions, such as the European Union, have set up systems to collect and recycle electrical and electronic waste items. Contact your local authorities for information about practices established for your region. If collection systems are not available, call Motorola Customer Service for assistance.



# Software License

IMPORTANT: PLEASE READ THIS SOFTWARE LICENSE ("LICENSE") CAREFULLY BEFORE YOU USE ANY SOFTWARE, FIRMWARE AND RELATED DOCUMENTATION ("SOFTWARE") PROVIDED WITH MOTOROLA'S DIGITAL CABLE RECEIVER OR HOME THEATER SYSTEM (EACH SHALL BE REFERRED TO IN THIS LICENSE AS A "RECEIVER"). BY USING THE RECEIVER AND/OR USING ANY OF THE SOFTWARE, YOU INDICATE YOUR ACCEPTANCE OF EACH OF THE TERMS OF THIS LICENSE. UPON ACCEPTANCE, THIS LICENSE WILL BE A LEGALLY BINDING AGREEMENT BETWEEN YOU AND MOTOROLA. THE TERMS OF THIS LICENSE APPLY TO YOU AND TO ANY SUBSEQUENT USER OF THIS SOFTWARE.

IF YOU DO NOT AGREE TO ALL OF THE TERMS OF THIS LICENSE (I) DO NOT USE THE SOFTWARE AND (II) RETURN THE RECEIVER AND THE SOFTWARE (COLLECTIVELY, "PRODUCT"), INCLUDING ALL COMPONENTS, DOCUMENTATION AND ANY OTHER MATERIALS PROVIDED WITH THE PRODUCT, TO YOUR POINT OF PURCHASE OR SERVICE PROVIDER, AS THE CASE MAY BE, FOR A FULL REFUND.

The Software includes associated media, any printed materials, and any "on line" or electronic documentation. Software provided by third parties may be subject to separate end user license agreements from the manufacturers of such Software. The Software is never sold. Motorola licenses the Software to the original customer and to any subsequent licensee for personal use only on the terms of this License. Motorola and its third party licensors retain the ownership of the Software.

**You may:**

USE the Software only in connection with the operation of the Product.

TRANSFER the Software (including all component parts and printed materials) permanently to another person, but only if the person agrees to accept all of the terms of this License. If you transfer the Software, you must at the same time transfer the Product and all copies of the Software (if applicable) to the same person or destroy any copies not transferred.

TERMINATE this License by destroying the original and all copies of the Software (if applicable) in whatever form.

**You may not:**

(1) Loan, distribute, rent, lease, give, sublicense or otherwise transfer the Software, in whole or in part, to any other person, except as permitted under the TRANSFER paragraph above. (2) Copy or translate the User Guide included with the Software, other than for personal use. (3) Copy, alter, translate, decompile, disassemble or reverse engineer the Software, including but not limited to, modifying the Software to make it operate on non compatible hardware. (4) Remove, alter or cause not to be displayed, any copyright notices or startup message contained in the Software programs or documentation. (5) Export the Software or the Product components in violation of any United States export laws.

The Product is not designed or intended for use in on line control of aircraft, air traffic, aircraft navigation or aircraft communications; or in design, construction, operation or maintenance of any nuclear facility. MOTOROLA AND ITS THIRD PARTY LICENSORS DISCLAIM ANY EXPRESS OR IMPLIED WARRANTY OF FITNESS FOR SUCH USES. YOU REPRESENT AND WARRANT THAT YOU SHALL NOT USE THE PRODUCT FOR SUCH PURPOSES.

Title to this Software, including the ownership of all copyrights, mask work rights, patents, trademarks and all other intellectual property rights subsisting in the foregoing, and all adaptations to and modifications of the foregoing shall at all times remain with Motorola and its third party licensors. Motorola retains all rights not expressly licensed under this License. The Software, including any images, graphics, photographs, animation, video, audio, music and text incorporated therein is owned by Motorola or its third party licensors and is protected by United States copyright laws and international treaty provisions. Except as otherwise expressly provided in this License, the copying, reproduction, distribution or preparation of derivative works of the Software, any portion of the Product or the documentation is



strictly prohibited by such laws and treaty provisions. Nothing in this License constitutes a waiver of Motorola's rights under United States copyright law.

This License and your rights regarding any matter it addresses are governed by the laws of the Commonwealth of Pennsylvania, without reference to conflict of laws principles. THIS LICENSE SHALL TERMINATE AUTOMATICALLY if you fail to comply with the terms of this License.

Motorola is not responsible for any third party software that is provided as a bundled application, or otherwise, with the Software or that is downloaded to, or otherwise installed on, the Product.

#### U.S. GOVERNMENT RESTRICTED RIGHTS

The Product and documentation is provided with RESTRICTED RIGHTS. The use, duplication or disclosure by the Government is subject to restrictions as set forth in subdivision (c)(1)(ii) of The Rights in Technical Data and Computer Software clause at 52.227 7013. The contractor/manufacturer is Motorola Mobility, Inc., 101 Tournament Drive, Horsham, PA 19044.



# Contents

<b>Safety &amp; Regulatory Information</b> .....	<b>i</b>
<b>Software License</b> .....	<b>iv</b>
<b>Tables</b> .....	<b>3</b>
<b>Figures</b> .....	<b>3</b>
<b>Introduction</b> .....	<b>5</b>
Features.....	6
Tuners .....	6
Standard Audio/Video Features.....	6
Standard DVR Functionality.....	7
Standard Data Features.....	8
Standard Miscellaneous Features .....	8
If You Need Help .....	8
Calling for Repairs.....	9
<b>Overview</b> .....	<b>10</b>
Front Panel.....	10
Video Format Indicators (Front Panel Display) .....	11
Rear Panel.....	12
M-Card™.....	12
<b>Installation</b> .....	<b>13</b>
Cold Reset Procedure.....	13
Remote Control Cold Reset .....	13
Clearing the Hard Drive .....	14
Video Connection Options .....	15
Audio Connection Options.....	16
Installation Overview .....	17
Connecting an HDTV — Single Connection for Video/Audio.....	18
Cable In .....	18
HDMI.....	18
IEEE-1394.....	18
Connecting an HDTV — Separate Video/Audio Connections .....	20
Cable In .....	20
Component Video (YPbPr).....	20
Audio .....	20
Connecting an A/V Receiver — Audio .....	22
Connecting a Standard-Definition TV (SDTV).....	24
Connecting a Standard-Definition TV (SDTV) and VCR/DVD Recorder.....	25






---

Connecting an A/V Receiver, SDTV, and VCR .....	27
Connecting to an External eSATA DVR/Hard Drive .....	29
Data Device Connections .....	30
Data Features .....	30
Operational Check for the Remote Control .....	31
<b>Configuring the User Settings .....</b>	<b>32</b>
User Settings Menu Main Screen .....	33
Native Mode Settings Screen .....	38
Additional HDMI Settings Screen .....	41
Additional Closed Caption Settings Screen .....	44
Subtitle and DVS Settings Screen .....	46
Advanced Audio/Video Settings Screen .....	48
Graphics Overlaying the Video .....	49
<b>Diagnostics .....</b>	<b>50</b>
Using the Diagnostics .....	50
General Status .....	51
Purchase Status .....	53
Out-Of-Band (OOB) Status .....	55
Agile OOB Tuner Hunting .....	57
In-Band Status .....	59
Unit Address .....	61
Separable Security .....	63
Current Channel Status .....	65
RF Modem (Upstream) .....	68
Code Modules .....	70
Memory Configuration .....	74
Audio/Video Status .....	74
Interface Status .....	78
DVR/Hard Drive Status .....	80
DOCSIS Status .....	83
Application Specific Information .....	86
Interactive Status .....	87
Connected Home .....	90
<b>Troubleshooting .....</b>	<b>92</b>



# Tables

Table 1: DVR recording time guidelines .....	7
Table 2: Audio Connection Options .....	16
Table 3: Operational check procedures .....	31
Table 4: User Settings—Main Menu Field Descriptions .....	35
Table 5: Native Mode Settings Field Descriptions .....	39
Table 6: Additional HDMI Settings Field Descriptions.....	42
Table 7: Additional Closed Caption Settings Field Descriptions.....	45
Table 8: Subtitle and DVS Settings Field Descriptions .....	47
Table 9: Advanced Audio/Video Settings Field Descriptions.....	49
Table 10: General Status Diagnostic Field Descriptions.....	52
Table 11: Purchase Status Diagnostic Field Descriptions .....	54
Table 12: OOB Diagnostic Field Descriptions .....	56
Table 13: In-Band Status Diagnostic Field Descriptions.....	60
Table 14: Unit Address Diagnostic Field Descriptions.....	62
Table 15: Separable Security Diagnostic Field Descriptions .....	63
Table 16: Current Channel Status Diagnostic Field Descriptions.....	66
Table 17: RF Upstream Modem Diagnostic Field Descriptions .....	70
Table 18: Code Modules Diagnostic Field Descriptions.....	72
Table 19: Memory Configuration Diagnostic Field Descriptions .....	74
Table 20: Audio/Video Status Diagnostic Field Descriptions.....	75
Table 21: Interface Status Diagnostic Field Descriptions.....	79
Table 22: DVR/Hard Drive Status Diagnostic Field Descriptions.....	81
Table 23: DOCSIS Status Diagnostic Field Descriptions.....	83
Table 24: Application Specific Information Diagnostic Field Descriptions.....	86
Table 25: Interactive Status Diagnostic Field Descriptions .....	88
Table 26: Connected Home Diagnostic Field Descriptions .....	91

# Figures

Figure 1: Front and rear views.....	6
Figure 2: Front panel.....	10
Figure 3: Rear Panel .....	12
Figure 4: Connecting an HDTV — Single Connection for Video/Audio.....	19
Figure 5: Connecting an HDTV — Separate Video/Audio Connections.....	21
Figure 6: Connecting an A/V Receiver — Audio .....	23
Figure 7: Connecting a Standard-definition TV (SDTV) .....	24



Figure 8: Connecting a Standard-Definition TV (SDTV) and VCR/DVD Recorder .....	26
Figure 9: Connecting an A/V Receiver, SDTV, and VCR.....	28
Figure 10: Connecting to an External eSATA DVR/Hard Drive.....	29
Figure 11: Examples of Data Devices You Can Connect to the DCX3510-M .....	30
Figure 12: Default User Settings Menu—No HDMI Connection .....	33
Figure 13: Default User Settings Menu —With HDMI Connection .....	34
Figure 14: User Settings Menu – Main Menu Screen.....	34
Figure 15: Native Mode Settings Menu Screen .....	38
Figure 16: Additional HDMI Settings Screen.....	41
Figure 17: Additional Closed Caption Settings Menu Screen .....	44
Figure 18: Subtitle and DVS Settings Menu Screen.....	46
Figure 19: Advanced Audio/Video Settings Menu Screen.....	48
Figure 20: Diagnostic Main Menu Screen .....	51
Figure 21: General Status Diagnostic Screen .....	51
Figure 22: Example General Status display (no error) .....	52
Figure 23: Purchase Status Diagnostic Screen .....	53
Figure 24: Front panel display for Purchase Status diagnostic.....	54
Figure 25: OOB Status Diagnostic Screen .....	55
Figure 26: Front panel display for the OOB diagnostic.....	55
Figure 27: In-Band Status Diagnostic Screen .....	59
Figure 28: Front panel display for in band diagnostic .....	59
Figure 29: Unit Address Diagnostic Screen.....	61
Figure 30: Front panel display of a unit address.....	61
Figure 31: Separable Security Diagnostic Screen.....	63
Figure 32: Current Channel Status Diagnostic Screens .....	65
Figure 33: Current Channel Status Front Panel Displays.....	65
Figure 34: RF Upstream Modem Diagnostic Screen.....	68
Figure 35: RF Upstream Modem Front Panel Display .....	69
Figure 36: Code Modules Diagnostic Screen .....	70
Figure 37: Front Panel Display For Code Modules .....	71
Figure 38: Memory Configuration Diagnostic Screen .....	74
Figure 39: Audio/Video Status Diagnostic Screen .....	75
Figure 40: Interface Status Diagnostic Screens .....	78
Figure 41: DVR/Hard Drive Status Diagnostic Screens .....	80
Figure 42: DOCSIS Status Diagnostic Screens .....	83
Figure 43: Application Specific Information Diagnostic Screen.....	86
Figure 44: Interactive Status Diagnostic Screen .....	87
Figure 45: Interactive Status Front Panel Display.....	87
Figure 46: Connected Home Diagnostic Screens .....	90



# 1

## Introduction

This manual provides instructions for cable operator personnel to install the Motorola DCX3510-M All-Digital High-Definition Dual Tuner DVR Cable Set-top. This unit includes a high-end processor, expanded memory, and enhanced graphics to support digital and on-demand broadcast and interactive services. It provides a full complement of interconnection options.

The DCX3510-M provides advanced capabilities, including:

- Authorization and purchase of on-demand programming
- Dual High-Definition (HDTV) decode of MPEG-2, MPEG-4 AVC (H.264), and VC-1
- HDTV output through component video (YPbPr), High-Definition Multimedia Interface™ (HDMI™), or IEEE-1394
- Surround-sound audio through a variety of digital interconnection options
- Dual-tuner DVR functionality to pause and time shift live video and seamlessly record in conjunction with the Interactive Programming Guide (IPG)
- DOCSIS 2.0+ embedded Cable Modem with support for DSG
- Ethernet and Universal Serial Bus (USB) 2.0 ports for future home networking applications
- Adaptability to various software platforms

As with all Motorola digital cable set-tops, the hardware features are enabled by core operating and third party application software.



**Figure 1: Front and rear views**

## Features

### Tuners

- Two all-digital 1 GHz (54 to 1002 MHz) video tuners
- MPEG-2 Main Profile @ High Level (High-Definition)
- MPEG-4 H.264 (AVC) High-Definition decode
- One dedicated tuner for the DOCSIS high-speed data services channel, up to 1 GHz
- One dedicated tuner for the out-of-band (OOB) control channel

### Standard Audio/Video Features

- ITU standard 64/256 QAM/FEC/enhanced adaptive equalizer
- DES based encryption/DCII (via inserted CableCARD™) access control
- Out-of-band data receiver (70-130 MHz) 2.048 Mbps
- Digital video scaling (picture in graphics)
- Accelerated 2-D and 3-D graphics support in hardware
- Macrovision® copy protection
- High-Definition video output through:



- o HDMI (also compatible with DVI using an HDMI-to-DVI converter cable)
- o Component video (YPbPr)
- o IEEE-1394
- Standard-Definition video output through Baseband
- Audio output through:
  - o S/PDIF optical digital audio connections
  - o One volume-adjustable Baseband L/R stereo analog audio connection

## Standard DVR Functionality

DVR functionality integrated with the IPG enables subscribers to:

- Pause, rewind, fast-forward, or record live TV
- Maintain a personal recorded program library and access it using the IPG
- Select programs to record across multiple channels and time slots
- Rewind and replay recorded programs
- Simultaneously watch two programs, switching easily between them using the swap key
- Record a program in the background while viewing another live program
- Simultaneously record programs from two channels while watching a different pre-recorded program, with the ability to switch viewing between any of the three programs

Motorola cannot guarantee the exact amount of programming that each subscriber will be able to record. The approximate time depends on the programming type and the drive size:

**Table 1: DVR recording time guidelines**

Model	Drive Size	Estimated Recording Hours For:	
		Standard Digital Channels	HDTV Channels
DCX3510-M	500 GB	350 to 700 (MPEG-4)	100 to 160 (MPEG-4)
		175 to 350 (MPEG-2)	50 to 60 (MPEG-2)

All times are approximate. The actual hours a subscriber can record are a function of program bit rate, the IPG type, and the reserved buffer space.



## Standard Data Features

- Integrated DOCSIS 2.0+ capable cable modem
- 64 MB FLASH memory
- 512 MB DRAM available to platform and applications
- One Universal Serial Bus (USB) 2.0 port
- One eSATA (external SATA) connector, un-powered for data-only connectivity, on the rear panel
- 10/100 Mbps Ethernet Port (RJ-45) on the rear panel
- On-board real-time RF return (DOCSIS compliant)

## Standard Miscellaneous Features

- Messaging capabilities
- Digital diagnostics
- Full feature access from front panel using a four-digit, seven-segment LED display

## If You Need Help

If you need assistance while working with the DCX3510-M, contact the Motorola Technical Response Center (TRC):

- Inside the U.S.: 1-888-944-HELP (1-888-944-4357)
- Outside the U.S.: 1-847-725-4011
- **Motorola Mobility Online (MOL):** <http://mobilityonline.motorola.com>.

The TRC is on call 24 hours a day, 7 days a week. In addition, Motorola Online offers a searchable solutions database, technical documentation, and low-priority issue creation and tracking. For specific toll-free numbers when calling from outside the United States, please refer to the product manual or our web page.



## Calling for Repairs

If a Motorola set-top requires repair service, please call one of the following Motorola Authorized Service Centers:

Company	From USA or Canada	Outside USA or Canada
World Wide Digital	1-800-227-0450	1-956-541-0600
Teleplan	1-800-352-5274	1-302-322-6088

To ensure efficient service, request a Return for Service Authorization (RSA) number. Be sure to display the RSA number prominently on all equipment boxes.

The Service Center will provide the shipping address of the location performing your repairs.

To ship your equipment for repair:

- Pack the unit securely, if possible in its original factory shipping carton.
- Print or display the RSA number so it is easily visible on all equipment boxes.
- Enclose a note describing the exact problem. Complete and enclose the checklist provided with the unit.
- Ship the unit *PREPAID* to the address provided by the Service Center.





# 2

## Overview

### Front Panel

The DCX3510 is streamlined with only a mechanical power button on the front panel to turn the set-top on and off. Certain functions, such as those requiring a numeric entry or accessing menus, require a remote control.



**Figure 2: Front panel**

Number	Description
1	Power — Turns the set-top on and off (standby)



## Video Format Indicators (Front Panel Display)

The front panel display of the DCX3510-M set-top is equipped with indicators to the right hand side of the display that are used to indicate the currently-selected video output format on the component video (YPbPr) and HDMI outputs.

The DCX3510-M set-top is capable of providing the following video formats on the YPbPr and HDMI video outputs:

- High Definition 1080i (1920 x 1080 pixels)
- High Definition 720p (1280 x 720 pixels)
- Enhanced Definition 480p (720 x 480 pixels)
- Standard Definition 480i (720 x 480 pixels)

The DCX3510-M set-top is also capable of passing through High-Definition 1080p 24/30/60 (1920 x 1080 pixels) source content over the HDMI video output.

If you cannot get a video display when the DCX set-top is connected to your television via component video or standard HDMI cables, use the User Settings Menu to optimize the DCX3510-M set-top display settings for your television.

*Note: Availability of certain features is dependent upon application support.*



## Rear Panel



**Figure 3: Rear Panel**

Number	Description
1	Cable In — Connects to cable signal from your service provider
2	Digital Audio (Optical S/PDIF) — Provides Dolby® Digital or PCM output
3	Video outputs / YPbPr — Component video output (HDTV)
4	Audio Out — L/R audio
5	HDMI — High-Definition TV (HDTV) connector
6	Video Out — Composite Video (SDTV)
7	eSATA* — External Serial Advanced Technology Attachment disk interface
8	USB* 2.0 — High-Speed peripheral device connection
9	Ethernet* — Network connection
10	External IR Input — Connects to a remote control set-top accessory cable Data test connector (service personnel only)
11	IEEE-1394 — Audio and video device connection
12	Power connector

\* Availability of certain features is dependent upon application support.

## M-Card™

The M-Card is required to view cable television programs, previously recorded programs on the DVR, or interactive on-demand programs. The M-Card should not be removed.



# 3

## Installation

Before you move or change components on the subscriber's entertainment system:

- Review the installation instructions.
- Determine if you are connecting the set-top to the TV by the composite (baseband) video input or a High-Definition video input (component video, HDMI, or IEEE-1394).
- Determine if the subscriber has other equipment to be connected to the terminal (home theater or A/V receiver, VCR, etc.).
- Verify that you have the necessary cables and other required items.
- If the terminal was previously used, clear its hard drive before installing it at a new subscriber location.

### Cold Reset Procedure

This section describes the *Cold Reset* procedure for Motorola's DCX3510-M set-top. The cold reset is generally used by operational and field personnel to accomplish the following:

- Restore the set-top to a known state.
- Clear channel maps and application settings.
- Remove application and software objects above the platform code.
- Clear the Out of Band (OOB) Last Known Carrier (LKC) and force the units to hunt for a new OOB control channel.

### Remote Control Cold Reset

1. Remove the set-top from its packaging.
2. Apply AC power to the set-top.
3. Point the remote control at the set-top and press the SELECT key.  
The POWER LED on the front panel begins to flash slowly.
4. Release the SELECT key.
5. Within 2 seconds, press the 3 key on the remote control.  
The POWER LED flashes quickly.
6. Within 2 seconds, press the 2 key on the remote control.  
The POWER LED will flash slowly.
7. Within 2 seconds, press the 8 key on the remote control.  
The POWER and MESSAGE LEDs flash two times, and the set-top performs a cold reset operation.



## Clearing the Hard Drive

On a previously-used cable terminal, delete all recorded programs from the hard drive before installing it at a new subscriber location. This prevents the new subscriber from viewing programming they may not have purchased or may not want to see.

To prevent subscribers from accidentally deleting all of their recorded programs, a specific set of keystrokes is required to clear the hard drive. The DCX3510-M does not need to be connected to a television in order to clear the hard drive using this process.

To clear the hard drive:

1. Start the diagnostics as described in the [Using the Diagnostics](#) section; d 01 is displayed on the front-panel display.
2. Using a remote control, within five seconds, press REPLAY, MY DVR three times, and LIVE TV. (On some remote controls, the MY DVR key may be labeled LIST.)
3. If you correctly enter this key sequence in five seconds or less, the hard drive is cleared and the front-panel displays *Clr*.
4. If *Clr* is not displayed, re-enter the key sequence in step 2.
5. If *Clr* is displayed, press any other key on the remote control to reset the terminal, turn it off, and complete the clearing process.



## Video Connection Options

Use the following guidelines to determine the best video connection for the subscriber home entertainment system. To determine the available video inputs on the TV, check the manual supplied with the TV or the TV itself.

The DCX3510-M offers the following video outputs:

Connection Type	TV Type	Options
<b>Component (YPbPr)</b>	HDTV and SDTV	The YPbPr output, providing three component analog video signals to the TV, is the most widely supported HD video connection.
<b>HDMI or IEEE-1394</b>	HDTV and SDTV	<ul style="list-style-type: none"> <li>• HDMI and IEEE-1394 provide higher-quality digital HD video signals than component video signals. If the TV has an HDMI or a DVI input, use the HDMI output instead of the IEEE-1394 output.</li> <li>• HDMI and IEEE-1394 are video and audio connections. If you use HDMI or IEEE-1394, no separate audio connection to the TV is required.</li> <li>• HDMI is compatible with DVI. If the TV has a DVI input, you can use an HDMI-to-DVI converter cable or adapter to connect the DVI-equipped TV to the HDMI-equipped DCX3510-M.</li> <li>• If you use the IEEE-1394 connection, the subscriber will be unable to see on-screen graphics (such as the EPG).</li> </ul>
<b>Video (composite)</b>	SDTV only	The composite video is an analog video connection for SDTV services and requires a separate audio connection.



## Audio Connection Options

When connecting to a home theater receiver, depending on its inputs, you can use the following DCX3510-M audio outputs:

**Table 2: Audio Connection Options**

Output	Connection
<b>HDMI</b>	<p>Unlike a DVI connection, an HDMI connection is capable of carrying digital video and audio signals to the TV or a home theater receiver equipped with HDMI switching support.</p> <p>The HDMI connection can deliver Dolby Digital Plus, Dolby Digital, Linear PCM, and other digital audio formats to a compatible TV or home theater receiver.</p>
<b>Digital audio optical (S/PDIF)</b>	<p>If the TV or home theater receiver supports it, use the S/PDIF digital audio optical output to deliver Dolby Digital and Linear PCM audio to a Dolby Digital home theater receiver.</p> <p>For an HDMI or IEEE-1394 video connection, no additional audio connections to the TV are required.</p>
<b>Baseband Audio L and R</b>	<p>If the audio receiver does not support Dolby Digital, use the baseband AUDIO L and R outputs to connect to the audio receiver.</p>

If the customer equipment supports it, use the optical S/PDIF output instead of the AUDIO L and R outputs. The S/PDIF output offers better audio quality, including support for Dolby Digital 5.1 Surround Sound. The HDMI interface supports Dolby® Digital Plus (7.1) audio.

The cabling diagrams show sample audio/video (A/V) connections to an audio receiver, where the receiver functions as an A/V router. When connecting to an audio receiver, reference its installation instructions for directions on connecting to baseband and digital audio (S/PDIF) ports.

*Note: The VCR and TV receive their A/V signals from the currently selected input device on the audio receiver. This is important when the subscriber has another A/V device such as a DVD player, secondary VCR, CD player, or other electronic component. Motorola recommends connecting the TV to the monitor output so on-screen menus for the receiver can be displayed. (Receivers themselves often have interactive on-screen menus.)*



## Installation Overview

1. Determine if you are connecting to a:
  - a. High-Definition TV or monitor:
    - Use the component video (YPbPr), HDMI, or IEEE-1394 outputs. No other video connection supports HDTV.
    - If the TV has a DVI input, connect a DVI-to-HDMI adapter or cable to the HDMI out connector on the DCX set-top instead of the IEEE-1394 connection and the DVI-HDTV connector on the TV.
  - b. Standard- Definition TV: Connect the composite video using a composite (RCA phono) cable.
2. Determine if you are connecting the audio to a home theater receiver or directly to the TV:
  - a. For an HDMI or IEEE-1394 video connection, no additional audio connections to the TV are required.
  - b. If the receiver or TV has a digital audio (S/PDIF) input, use the digital audio optical (S/PDIF) output. Otherwise, use the baseband left and right audio out outputs.
3. Locate the cabling diagram(s) that best match the subscriber's configuration.
4. Connect the audio and video cables in a manner matching that diagram.
5. Determine if you are connecting to a data device (see [Data Device Connections](#)). For installation details, refer to the instructions included with the data device.
6. Connect the cable terminal to the coaxial cable wall outlet.
7. Perform the operational check for the remote control.
8. Optimize the High-Definition settings. See [Configuring the User Settings](#) in this manual.





## Connecting an HDTV — Single Connection for Video/Audio

This section describes steps to connection the DCX to an HDTV using connection options that combine video and audio into a single cable.

### Cable In

Connect an RF coaxial cable to the cable wall outlet and the cable in connector on the DCX set-top.

### HDMI

If the TV has an HDMI input, this is for both audio and video if you are using the TV speakers. Connect a Standard HDMI cable to the TV and to the HDMI connector on the DCX set-top.

### IEEE-1394

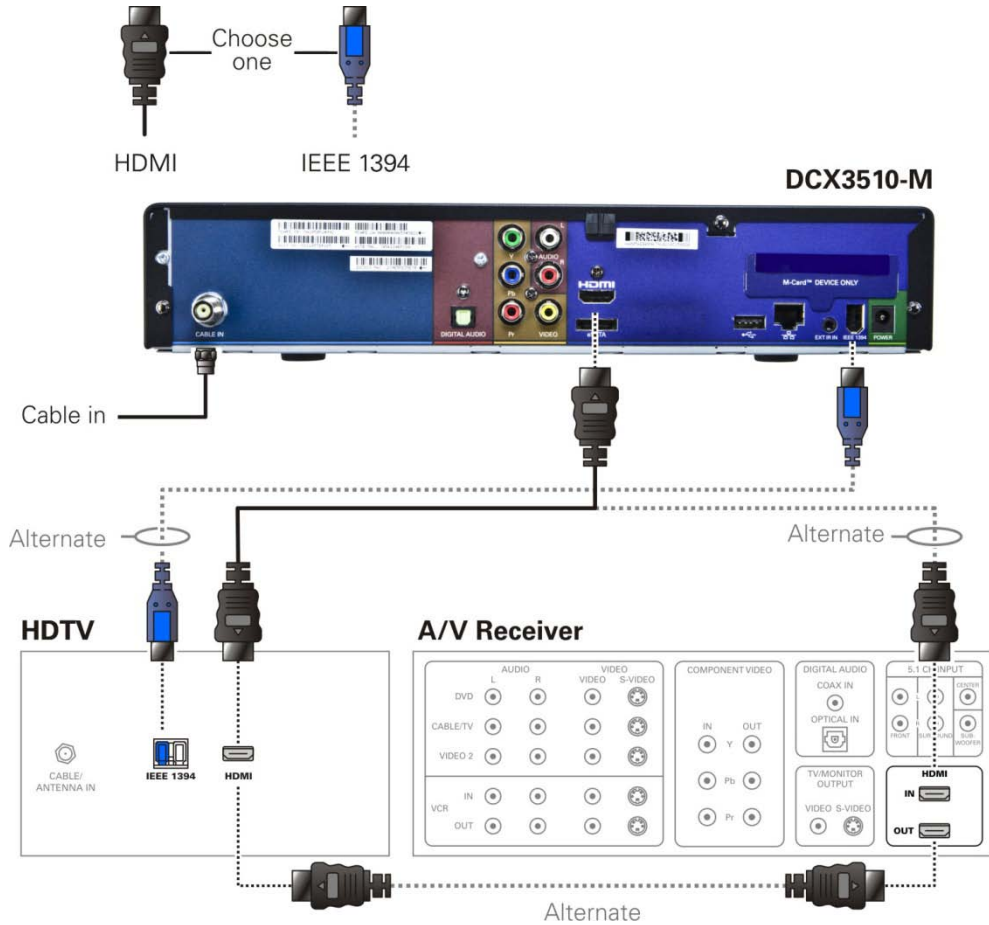
If the HDTV has an IEEE-1394 connector, you can use the IEEE-1394 for both the video and audio connection:

Connect an IEEE-1394 cable to the IEEE-1394 connector on the HDTV and DCX set-top.

*Note: On-screen graphics are not displayed when you are using the IEEE-1394 connection on the rear panel of the DCX set-top.*

If there is an audio/video receiver and you are not using the TV's speakers, go to [Connecting an A/V Receiver — Audio](#).

*Because HDMI and IEEE-1394 provide both video and audio output, no additional audio connections to the TV are required if you use either of these connections.*



**Figure 4: Connecting an HDTV – Single Connection for Video/Audio**

*Note: Only (1) HDTV video/audio connection needs to be made to an HDTV.*

*Note: On-screen graphics will not be displayed when using IEEE-1394 connection. Refer to [Graphics Overlaying the Video](#) for more information.*

*Note: Solid lines indicate optimum connections.*

*Note: Optional HDMI connection to A/V Receiver shown but not required.*



## Connecting an HDTV — Separate Video/Audio Connections

### Cable In

Connect an RF coaxial cable to the cable wall outlet and the cable in connector on the DCX set-top.

### DVI

If the TV has a DVI input, use the DVI connection for the video:

- Connect a HDMI-to-DVI adapter or cable to the HDMI out connector on the DCX set-top and the DVI-HDTV connector on the TV.

*Note: A DVI connection supports only the video connection between the DCX set-top and the HDTV. To connect your audio connections with your TV speakers, go to the [Audio](#) section below. To connect the audio connections for an A/V receiver, go to [Connecting an A/V Receiver — Audio](#).*

### Component Video (YPbPr)

Connect the component video cables to the **Y**, **Pb**, and **Pr** connectors on the HDTV and DCX set-top.

*Note: This connection supports only the High-Definition video connection between the DCX set-top and the HDTV. Be sure to match up each signal to the same connection on the TV, otherwise the colors will not appear correctly on the TV.*

*Note: To connect your audio connections with your TV speakers, go to the [Audio](#) section below.*

### Audio

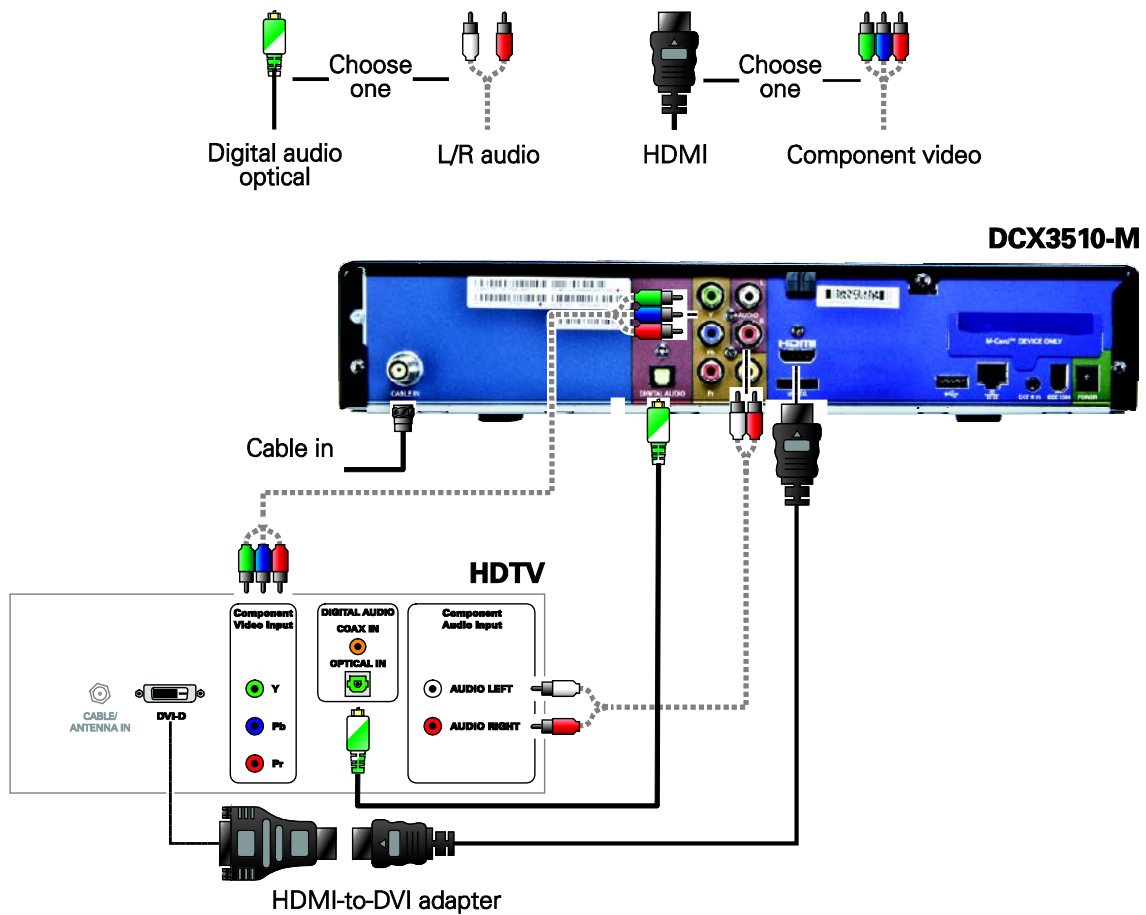
If the TV does not have digital audio inputs:

- Connect the stereo audio cable to the audio l and r connectors on the DCX3510-M Series set-top and the audio left and audio right connectors on the HDTV.

If the TV supports a digital audio input:

- If the equipment supports it, use the digital audio optical S/PDIF output instead of the audio l and r outputs. S/PDIF offers better audio quality, including support for Dolby® Digital audio.

For information on configuring the DCX set-top settings, see [Configuring the User Settings](#).



**Figure 5: Connecting an HDTV – Separate Video/Audio Connections**

*Note: If the receiver can check the baseband and digital audio (S/PDIF) ports for appropriate channels, connect both the baseband and digital audio connections. Otherwise, do not connect both the baseband left/right composite connections and the coaxial digital connection. The baseband connections are not necessary because the digital audio port provides a single audio interface for digital channels.*

*Note: If the A/V receiver includes HDMI inputs and output(s), then the DCX3510-M HDMI output can be directly connected to the A/V receiver.*



## Connecting an A/V Receiver — Audio

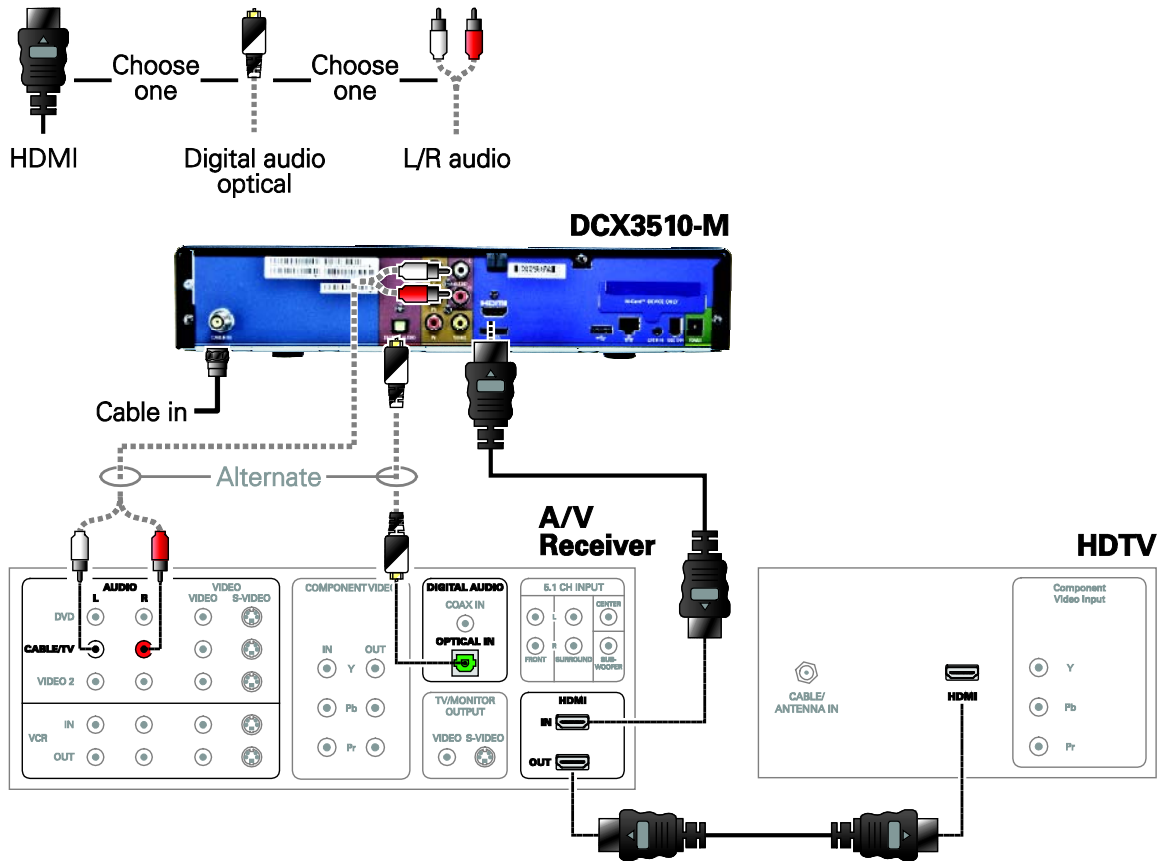
There are several options available for audio connections to the A/V receiver:

- Digital audio (OPTICAL S/PDIF)
- Stereo audio (AUDIO L and R)

If the A/V receiver supports it, the optical S/PDIF digital audio output may be used in place of the stereo audio outputs (audio L and R). These outputs offer a higher level of audio quality, including support for Dolby Digital audio.

- **Digital audio optical (S/PDIF)**—Connect the optical cable to the digital audio OPTICAL connector on the DCX set-top and the optical connector on the A/V receiver.
- **Stereo audio**—Connect the stereo audio cable to the AUDIO L and R connectors on the DCX set-top and the AUDIO L and AUDIO R connectors on the A/V receiver.

For information on configuring the DCX set-top settings, see [Configuring the User Settings](#).



**Figure 6: Connecting an A/V Receiver – Audio**

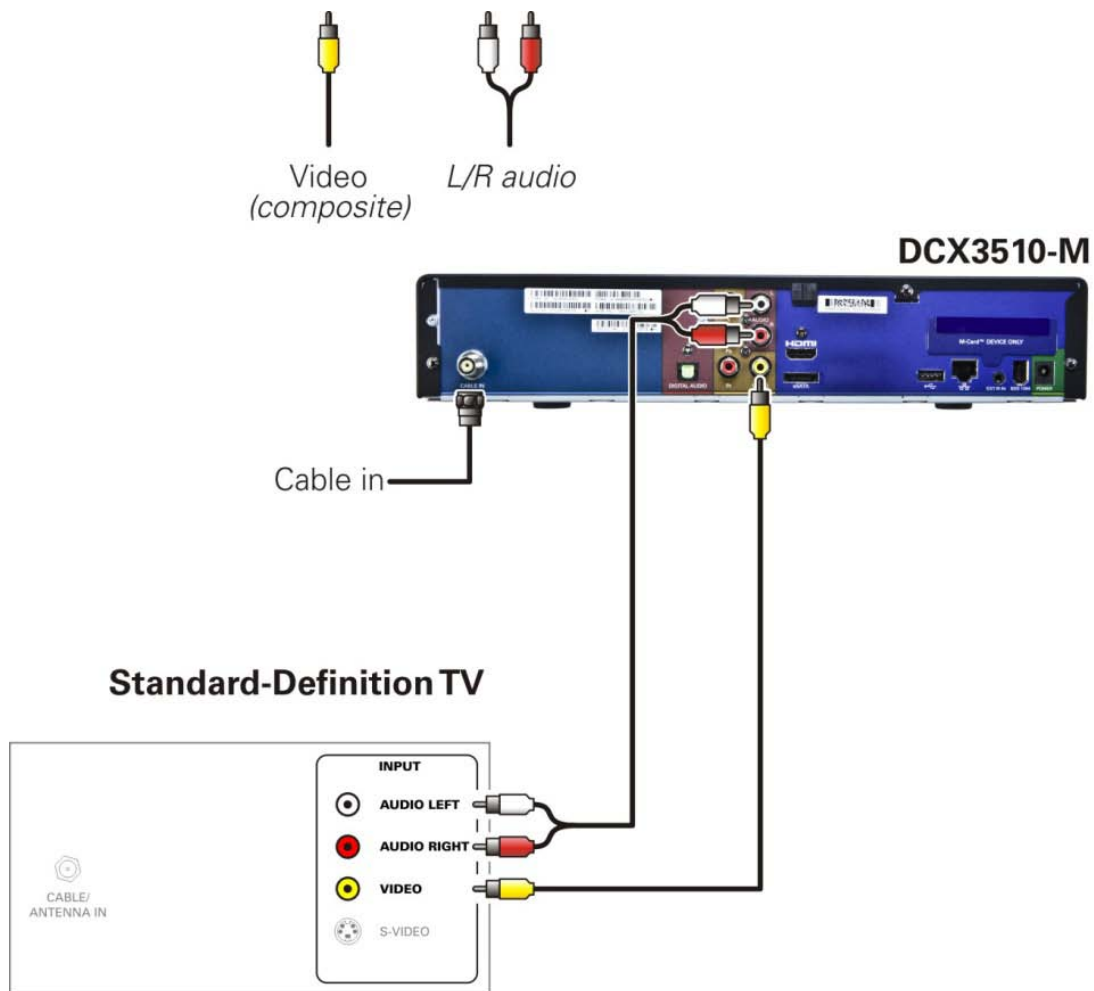
*Note: This connection method does not support HDTV. For information, see [Connecting an HDTV — Separate Video/Audio Connections](#) in this section.*



## Connecting a Standard-Definition TV (SDTV)

1. Connect the stereo audio cable to the AUDIO L and R connectors on the DCX3510-M series set-top and the AUDIO L and R connectors on the SDTV.
2. Connect a video cable to the VIDEO OUT connector on the DCX3510-M series set-top and the INPUT VIDEO on the TV.

*Note: These video connection methods do not support HD video. If you have an HDTV, see [Connecting an HDTV — Separate Video/Audio Connections](#).*



**Figure 7: Connecting a Standard-definition TV (SDTV)**

*Note: Composite video requires separate audio connections.*

*Note: Only one video connection and one audio connection are required.*

*Note: Solid lines indicate optimum connections.*



---

## Connecting a Standard-Definition TV (SDTV) and VCR/DVD Recorder

1. Connect a stereo audio cable to the AUDIO OUT L and R connectors on the DCX3510-M and the INPUT AUDIO L and R connectors on the VCR/DVD Recorder.
2. Connect a video cable to the VIDEO OUT connector on the DCX3510-M and the INPUT VIDEO connector on the VCR/DVD Recorder.
3. Connect a stereo audio cable to the OUTPUT AUDIO L and R connectors on the VCR/DVD Recorder and the INPUT AUDIO L and R connectors on the SDTV.
4. Connect a video cable to the OUTPUT VIDEO connector on the VCR/DVD Recorder and the INPUT VIDEO connector on the SDTV.

*Note: These video connection methods do not support HD video. If there is an HDTV, see [Connecting an HDTV — Separate Video/Audio Connections](#).*



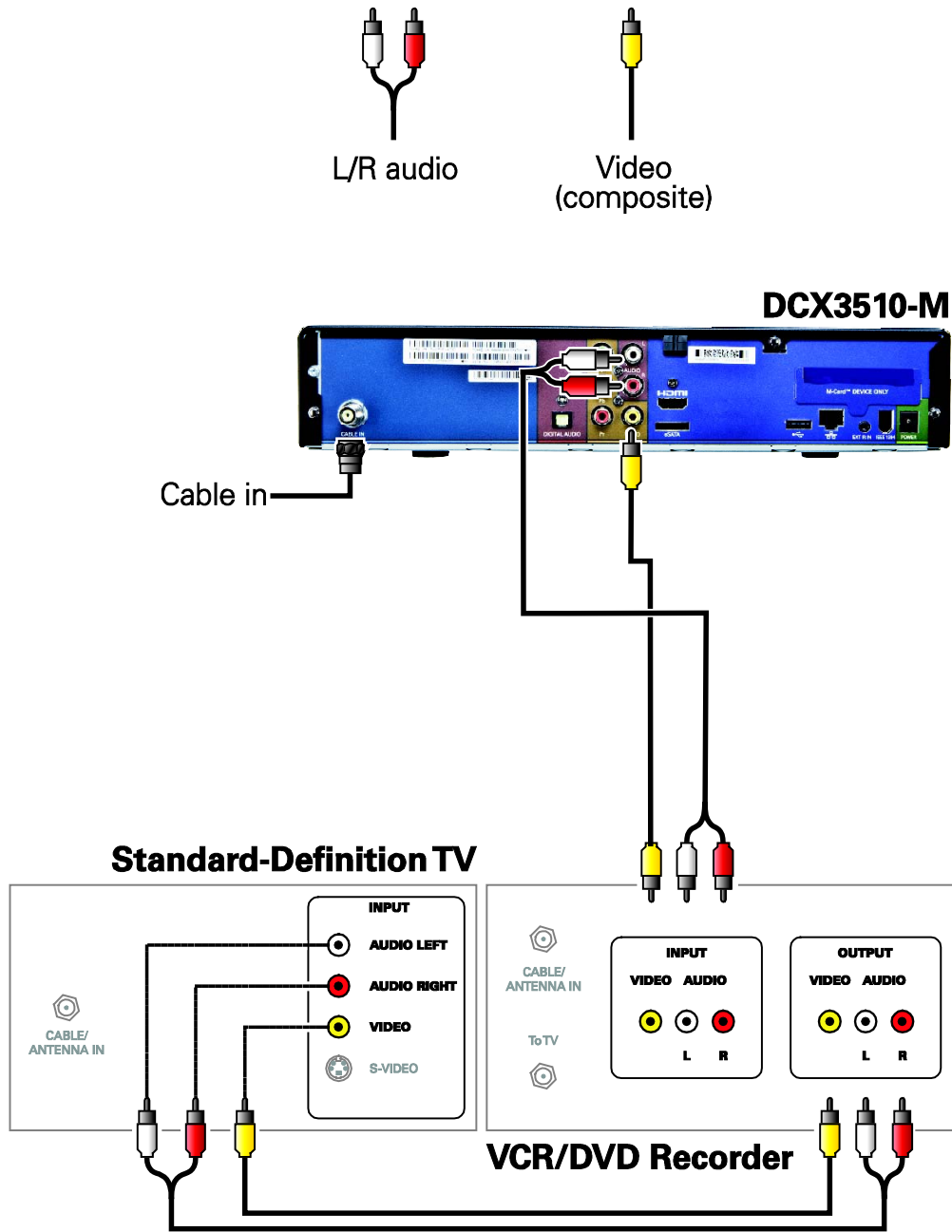


Figure 8: Connecting a Standard-Definition TV (SDTV) and VCR/DVD Recorder

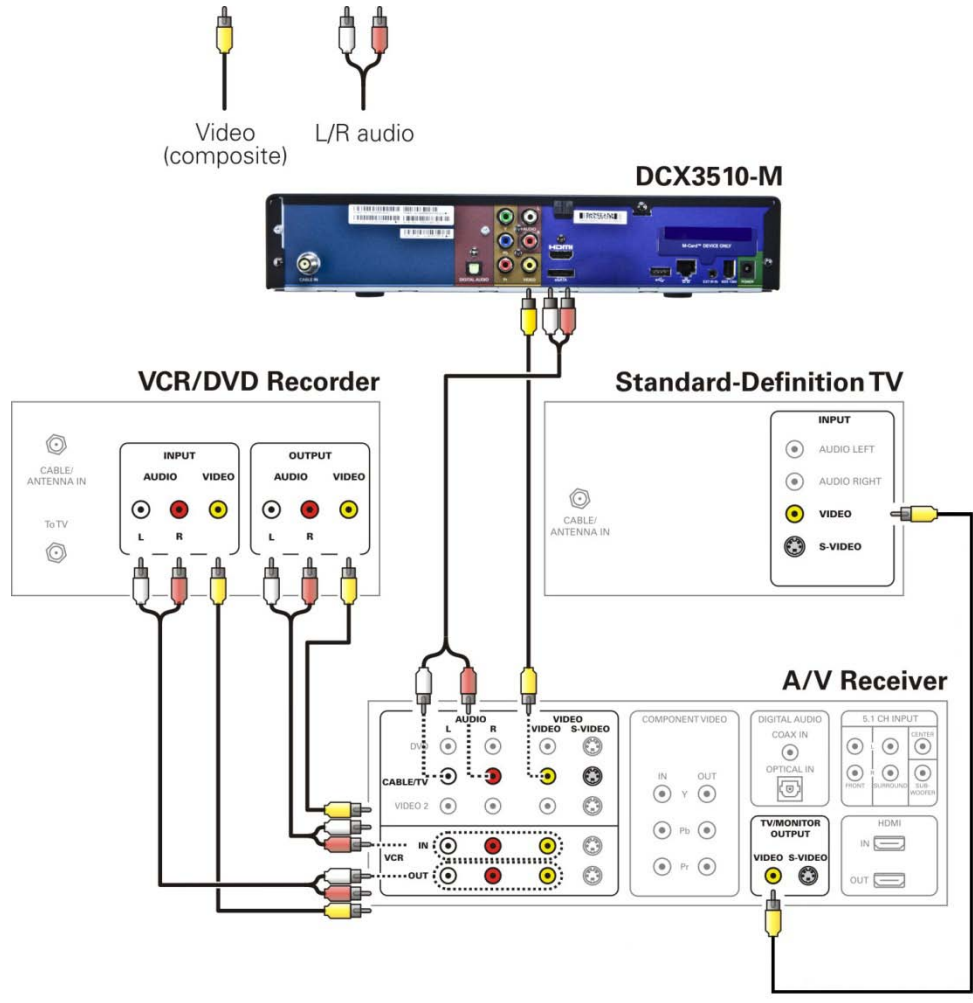


## Connecting an A/V Receiver, SDTV, and VCR

1. Connect a stereo audio cable to the AUDIO OUT L/R connectors on the DCX3510-M series set-top and the INPUT L/R connectors on the A/V receiver.
2. Connect a composite video cable to the composite video out connector on the DCX3510-M series set-top and the composite video connector on the A/V receiver.
3. Connect a stereo audio cable to the VCR AUDIO OUT L/R connectors on the A/V receiver and the INPUT AUDIO L/R connectors on the stereo VCR.
4. Connect a stereo audio cable to the OUTPUT AUDIO OUT L/R connectors on the stereo VCR and the VCR AUDIO IN L/R connectors on the A/V receiver.
5. Connect a composite video cable to the input video connector on the stereo VCR and the video VCR OUT connector on the A/V receiver.
6. Connect a composite video cable to the output video connector on the stereo VCR and the video VCR IN connector on the A/V receiver.
7. Connect a Composite Video cable to the input Composite Video connector on the Standard-Definition TV (SDTV) and the TV/monitor output Composite Video connector on the A/V receiver.

*Note: The digital audio optical (OPTICAL S/PDIF) output may be used in place of the stereo audio outputs (AUDIO L/R). Optical S/PDIF offers a higher level of audio quality, including support for Dolby Digital audio.*

*Note: These video connection methods do not support HD video. If there is an HDTV, see [Connecting an HDTV — Separate Video/Audio Connections](#).*



**Figure 9: Connecting an A/V Receiver, SDTV, and VCR**

*Note: Solid lines indicate optimum connections.*

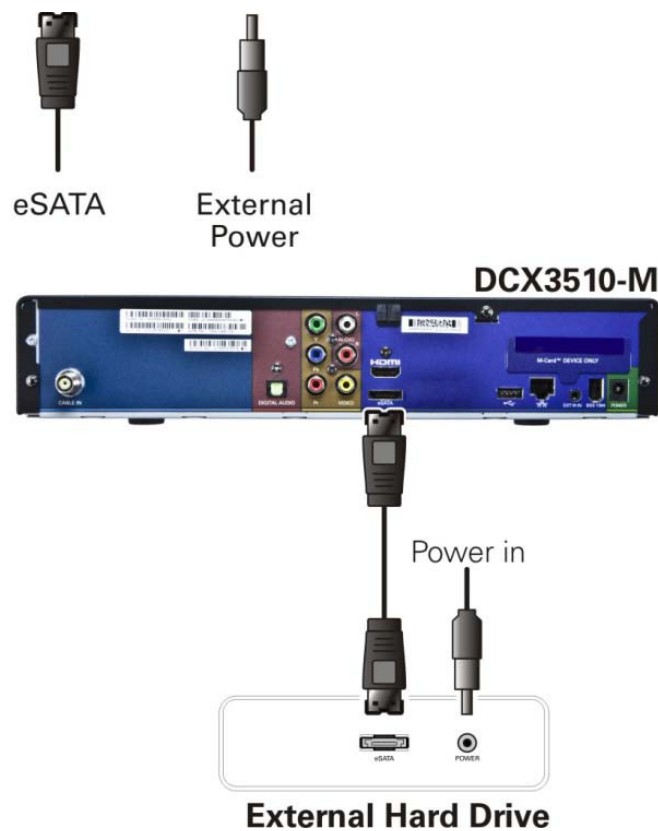
*Note: Consult your A/V receiver manual for additional wiring options or constraints when including a VCR/DVD Recorder in your configuration.*



## Connecting to an External eSATA DVR/Hard Drive

1. Contact your cable service provider to verify the set-top software necessary to support External DVR Storage is available in your area.
2. Connect the AC power cord to the external drive and plug the external drive's AC power adapter into an electrical outlet.
3. Allow approximately 15 to 30 seconds for the external drive to reach operating speed.
4. Connect one end of the eSATA cable to the set-top.
5. Connect the other end of the eSATA cable to the external drive.
6. Follow the on-screen instructions.

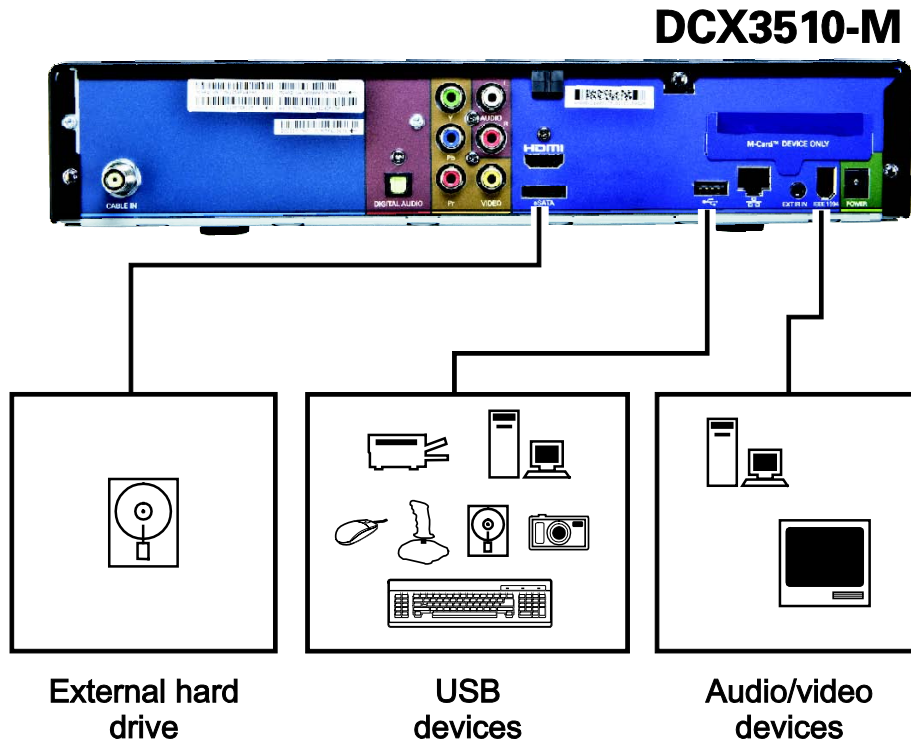
*Note: Only connect external hard drives that have been approved by Motorola for external DVR service. Connecting an external drive that has not been approved could result in poor DVR performance.*



**Figure 10: Connecting to an External eSATA DVR/Hard Drive**



## Data Device Connections



**Figure 11: Examples of Data Devices You Can Connect to the DCX3510-M**

Do not attempt to connect data devices without contacting your service provider. Advanced data features require the proper application and network infrastructure to operate.

### Data Features

In addition to high-quality audio and video, the DCX3510-M can deliver high-speed data services such as Internet access, e-mail, IP telephony, e-commerce, and home banking.

*Note: Your DCX may be equipped with the interface connections illustrated, but their functionality depends on the services offered by your service provider.*



## Operational Check for the Remote Control

The operational check tests communication with the remote control:

**Table 3: Operational check procedures**

Feature	Testing Procedure
<b>Power on</b>	Press power on the remote control to turn on the DCX3510-M. Tune to the output channel (3 or 4), if using the RF output.
<b>Channel selection</b>	Scan through the channels using the channel + or - keys. Tune to several channels by entering the channel number using the numeric keys.
<b>Volume control</b>	Press volume + or - on the remote control to increase the volume to its upper limit, lowest level, and to a comfortable level. Press mute to turn the sound off. Press mute again to restore the sound.

If the DCX3510-M does not operate properly, refer to the Troubleshooting section.



# 4

## Configuring the User Settings

The following describes how to configure the audio (for HDMI connections), SD and HD video, closed caption, subtitle, and power settings for the DCX3501-M.

Before you adjust the output settings:

1. Connect the DCX3501-M to the TV and other home entertainment devices
2. Connect the provided power supply to the DCX3501-M and an AC power outlet
3. Initialize the DCX3501-M and authorize it for services
4. Turn the TV on

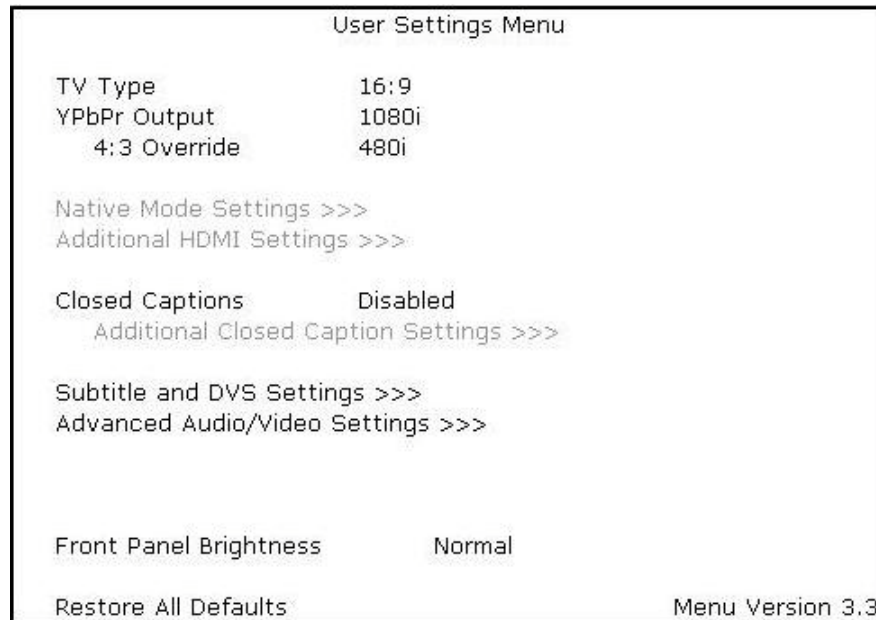
*Note: When using an HDMI connection between the DCX3501-M and the television, be sure to have the cable connected and the TV powered on before adjusting the video settings.*



## User Settings Menu Main Screen

To configure the DCX3510-M settings on the main User Settings menu screen, first power off the DCX3510-M using either the remote control or the Power button and then press the MENU key on the remote control. If the TV is on, the on-screen User Settings menu lists the DCX3510-M settings that can be adjusted.

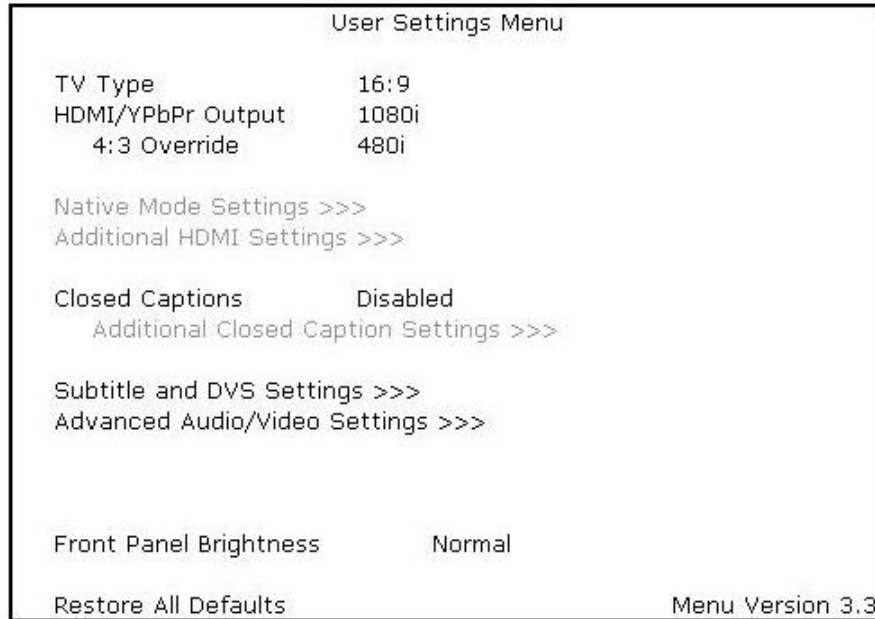
If no HDMI device is connected to the DCX3510-M, the default User Settings menu appears as follows:



**Figure 12: Default User Settings Menu—No HDMI Connection**

If the DCX3510-M is connected via HDMI to a display device such as a television, the default User Settings menu is updated to reflect this information. The YPbPr Output menu option is replaced with the HDMI/YPbPr Output menu option as follows.

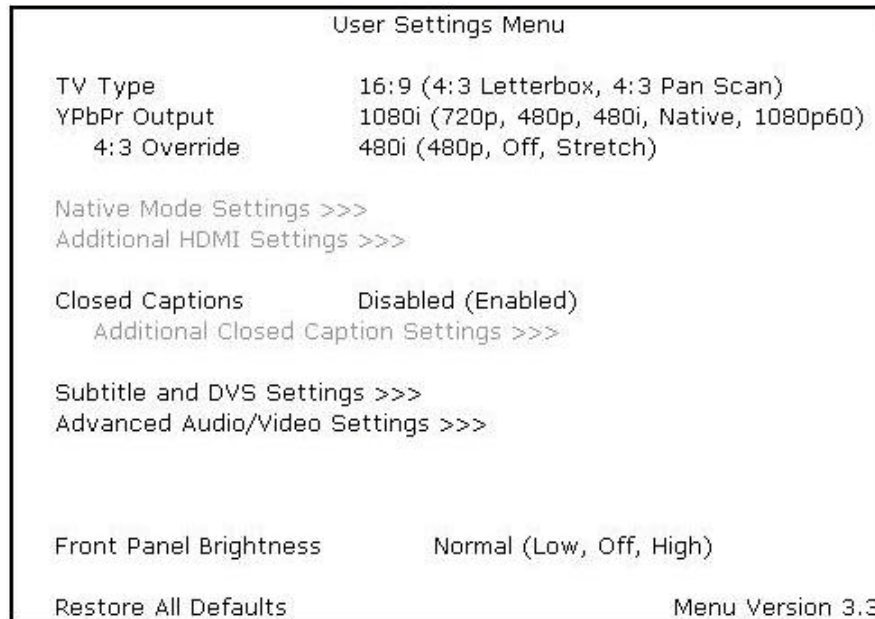




**Figure 13: Default User Settings Menu – With HDMI Connection**

Use the remote control cursor keys to navigate the on-screen menus as follows:

- Press the ▲ and ▼ keys to highlight the setting you wish to change.
- Press the ► key to select an option.
- To exit the setting and move to another setting, press the ▲ or ▼ key.



**Figure 14: User Settings Menu – Main Menu Screen**

**Table 4: User Settings—Main Menu Field Descriptions**

Setting	Description
<b>TV Type</b>	<p>Allows you to specify the style of television connected to the DCX3510-M. The 16:9 option is the default.</p> <ul style="list-style-type: none"> <li>• <b>16:9</b>— A widescreen television is connected to the DCX3510-M.</li> <li>• <b>4:3 Letterbox</b> — A standard-screen television is connected to the DCX3510-M and widescreen programs should be scaled to fit the screen with black bars above and below the picture.</li> <li>• <b>4:3 Pan Scan</b>—A standard-screen television is connected to the DCX3510-M and widescreen programs should be cropped so the picture fills the entire screen.</li> </ul>
<b>HDMI/YPbPr Output</b>	<p>Allows you to select the video format of the HDMI and/or Component Video (YPbPr) outputs:</p> <ul style="list-style-type: none"> <li>• For ALL programs when the 4:3 Override setting is set to either Off or Stretch.</li> <li>• For ONLY widescreen programs when the 4:3 Override is set to either 480i or 480p.</li> </ul> <p>The 1080i option is the default.</p> <ul style="list-style-type: none"> <li>• <b>1080p60</b>—High-Definition 1080p60 format (1920 x 1080 pixels with progressive scanning at 60 frames per second).</li> <li>• <b>1080i</b>—High-Definition 1080i format (1920 x 1080 pixels with interlaced scanning at 30 frames per second).</li> <li>• <b>720p</b>—High-Definition 720p format (1280 x 720 pixels with progressive scanning at 60 frames per second).</li> <li>• <b>480p</b>—Enhanced-Definition 480p format (720 x 480 pixels with progressive scanning at 60 frames per second).</li> <li>• <b>480i</b>—Standard-Definition 480i format (720 x 480 pixels with interlaced scanning at 30 frames per second).</li> <li>• <b>Native</b>—Format that most closely matches the program’s native format according to the list of compatible formats selected from the Native Mode Settings menu screen.</li> </ul> <p><i>Note : Not all televisions will support all available video formats. Consult the television’s user manual for more information on video format compatibility.</i></p> <p><i>The DCX3510-M can detect when the HDMI connection is in use. If you are not using the HDMI connection on the DCX3510-M, the HDMI/YPbPr Output setting will display as YPbPr Output in the User Settings Menu.</i></p> <p><i>Most new HDTVs are equipped with at least one HDMI input and can support the 1080p60 format. The DCX3510-M is designed to provide excellent video quality when converting any program to the 1080p60 video format. If your television supports 1080p60 video input, it is highly recommended to adjust the HDMI/YPbPr Output setting to the 1080p60 setting.</i></p>



Setting	Description
<b>4:3 Override</b>	<p>Allows you to select the video output format of the DCX3510-M when it is tuned to a Standard-Definition program or playing back a Standard- Definition program from the DVR. The 480i option is the default.</p> <ul style="list-style-type: none"> <li>• <b>480i</b>—Standard-Definition 480i format (720 x 480 pixels).</li> <li>• <b>480p</b>—Enhanced-Definition 480p format (720 x 480 pixels).</li> <li>• <b>Stretch</b>—Automatically stretch all Standard-Definition programs to a widescreen (16:9) aspect ratio and present the video in the format designated by the HDMI/YPbPr Output setting. Note that the Stretch option is only available when the TV Type setting is 16:9.</li> <li>• <b>Off</b>—Widescreen version of a Standard-Definition program with black bars to the left and the right of the picture (pillarbox) and the video presented in the format designated by the HDMI/YPbPr Output setting.</li> </ul> <p><i>Note: Not all televisions support all available video formats. Consult your television's user manual for more information on format compatibility.</i></p> <p><i>If the HDMI/YPbPr Output setting is set to either 480i or Native, the 4:3 Override feature is disabled and can't be selected in the menu. The 4:3 Override feature is available when the HDMI/YPbPr Output setting is 1080i, 720p, or 480p.</i></p>
<b>Native Mode Settings</b>	<p>Allows you to customize the Native Mode feature of the DCX3510-M by selecting the video formats supported by your television.</p> <p>Selecting the Native Mode Settings option presents a new menu screen with settings specific to Native Mode operation. These settings are discussed in more detail below.</p> <p>The Native Mode Settings option is only available when the HDMI/YPbPr Output setting is set to Native. Otherwise, the Native Mode Settings option is disabled and can't be selected in the menu.</p>
<b>Additional HDMI Settings</b>	<p>Available whenever an HDMI device is connected to the DCX3510-M. Selecting this option presents a new menu screen with settings specific to the HDMI connection. These settings are discussed in more detail below.</p> <p>If no HDMI device is connected to the DCX3510-M, this option is disabled and can't be selected in the menu.</p>
<b>Closed Captions</b>	<p>Turns closed captions off or on.</p> <p>When this option is set to Disabled, the DCX3510-M does not render (draw) closed captions on any video output.</p> <p>When this option is set to Enabled, the DCX3510-M renders (draws) closed captions on all video outputs if closed captions are included in the program. Disabled is the default setting.</p>



Setting	Description
<b>Additional Closed Caption Settings</b>	<p>Allows you to customize the style and appearance of closed captions.</p> <p>Selecting this presents a new menu screen with settings specific to closed captions, including font style, color, and size. These settings are discussed in more detail below.</p> <p>The Additional Closed Caption Settings option is only available when the Closed Captions setting is set to Enabled. Otherwise, the Additional Closed Caption Settings option is disabled and can't be selected in the menu.</p>
<b>Subtitle and DVS Settings</b>	<p>Allows you to customize the operation of the subtitle and descriptive video service features.</p> <p>Selecting the Subtitle and DVS Settings option presents a new menu screen with settings specific to subtitle and descriptive video service operation. These settings are discussed in more detail below.</p>
<b>Advanced Audio/Video Settings</b>	<p>Allows you to customize several advanced audio and video features of the DCX3510-M.</p> <p>Selecting this option presents a new menu screen with settings specific to closed captions, including font style, color, and size. These settings are discussed in more detail below</p>
<b>Front Panel Brightness</b>	<p>Allows you to adjust the brightness level of the front panel display (clock/channel number and indicator icons) of the DCX3510-M.</p> <ul style="list-style-type: none"> <li>• <b>High</b>—The brightest level. This setting is most useful when using the DCX3510-M in very brightly lit rooms.</li> <li>• <b>Normal</b>—The default brightness level.</li> <li>• <b>Low</b>—The lowest (visible) brightness level. This setting is most useful when using the DCX3510-M in dim or dark rooms.</li> <li>• <b>Off</b>—The front panel display will be turned off completely, including the clock/channel number and all indicator icons. The blue backlighting of the front panel Power button remains illuminated.</li> </ul>
<b>Restore All Defaults</b>	<p>To reset ALL of the DCX3510-M User Settings to their default values, including options stored on other menu screens, move the cursor to this option and press the ► key.</p>



## Native Mode Settings Screen

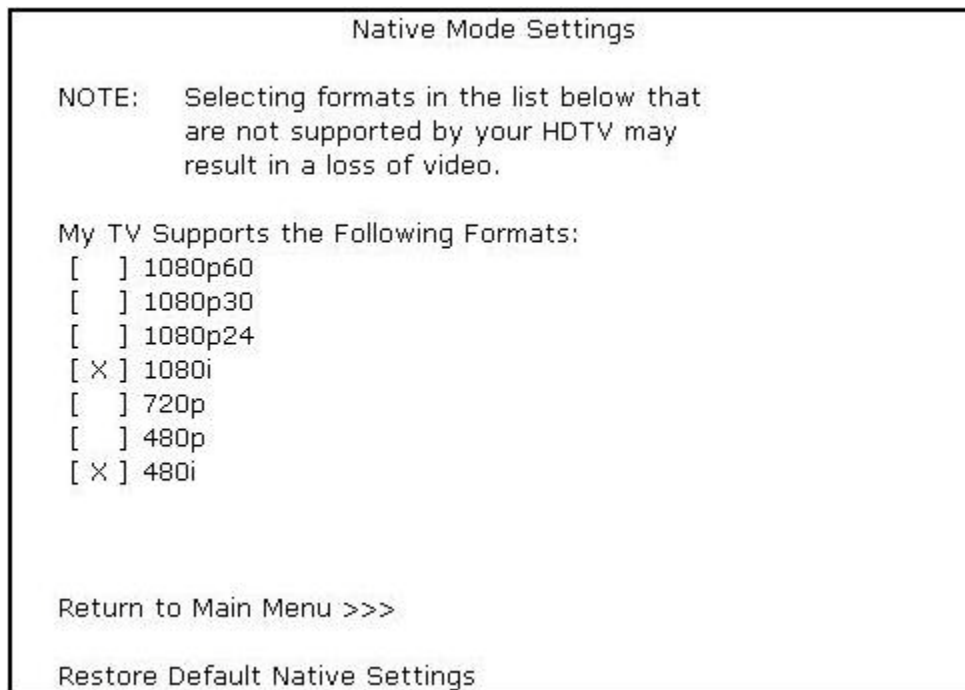
The Native Mode Settings menu configures the operation of the native mode feature on the DCX3510-M. The DCX3510-M can receive and decode a number of different digital video formats. When operating in native mode, the DCX3510-M generates the video output format that most closely matches the broadcast video format.

For example, if the DCX3510-M is configured to operate in native mode, a channel broadcast in the 720p format is output to the television in the 720p format, while a channel broadcast in the 1080i format is output to the television in the 1080i format.

When using the native mode feature of the DCX3510-M, please exercise caution when selecting the formats from the checklist. If a format is selected that is not compatible with the television, there may be a loss of video whenever the DCX3510-M is tuned to a channel broadcast in that format.

If the television is connected to the DCX3510-M using an HDMI cable, the DCX3510-M automatically customizes the checklist of supported formats reported by the television. If the television is connected to the DCX3510-M using Component Video (YPbPr) cables, the checklist needs to be customized manually.

*Note: At least one of the [1080p - 1080i - 720p - 480p - 480i] formats must be selected from the checklist for the DCX3510-M to operate properly in native mode.*



**Figure 15: Native Mode Settings Menu Screen**

**Table 5: Native Mode Settings Field Descriptions**

Setting	Description
<b>1080p60</b> <b>(High Definition)</b>	<p>Generates 1080p60 video on the HDMI output if the program is broadcast in 1080p60 format. The DCX3510-M can also convert any other broadcast format to the 1080p60 video format.</p> <p>1080p60 is a high-definition video image with 1920 x 1080 pixels, progressive scanning, and a frame rate of 60 frames per second.</p> <p>This option is only available if the DCX3510-M is connected to an HDMI display device. If no HDMI connection is detected, this option is disabled and can't be selected in the menu.</p> <p><i>Note: The Component Video (YPbPr) output delivers 480i video whenever the HDMI output is delivering 1080p60 video.</i></p>
<b>1080p30</b> <b>(High Definition)</b>	<p>Generates 1080p30 video on the HDMI output if the program is broadcast in 1080p30 format. The DCX3510-M cannot convert any other broadcast format to the 1080p30 video format.</p> <p>1080p30 is a high-definition video image with 1920 x 1080 pixels, progressive scanning, and a frame rate of 30 frames per second.</p> <p>This option is only available if the DCX3510-M is connected to an HDMI display device. If no HDMI connection is detected, this option is disabled and can't be selected in the menu.</p> <p><i>Note: The Component Video (YPbPr) output delivers 480i video whenever the HDMI output is delivering 1080p30 video.</i></p>
<b>1080p24</b> <b>(High Definition)</b>	<p>Generates 1080p24 video on the HDMI output if the program is broadcast in 1080p24 format. The DCX3510-M cannot convert any other broadcast format to the 1080p24 video format.</p> <p>1080p24 is a high-definition video image with 1920 x 1080 pixels, progressive scanning, and a frame rate of 24 frames per second.</p> <p>This option is only available if the DCX3510-M is connected to an HDMI display device. If no HDMI connection is detected, this option is disabled and can't be selected in the menu.</p> <p><i>Note: The Component Video (YPbPr) output delivers 480i video whenever the HDMI output is delivering 1080p24 video.</i></p>
<b>1080i</b> <b>(High Definition)</b>	<p>Generates 1080i video on both the HDMI and Component Video (YPbPr) outputs if the program is broadcast in 1080i format. The DCX3510-M can also convert any other broadcast format to the 1080i video format.</p> <p>1080i is a high-definition video image with 1920 x 1080 pixels, interlaced scanning, and a frame rate of 30 frames per second.</p>
<b>720p</b> <b>(High Definition)</b>	<p>Generates 720p video on both the HDMI and Component Video (YPbPr) outputs if the program is broadcast in 720p format. The DCX3510-M can also convert any other broadcast format to the 720p video format.</p> <p>720p is a high-definition video image with 1280 x 720 pixels, progressive scanning, and a frame rate of 60 frames per second.</p>

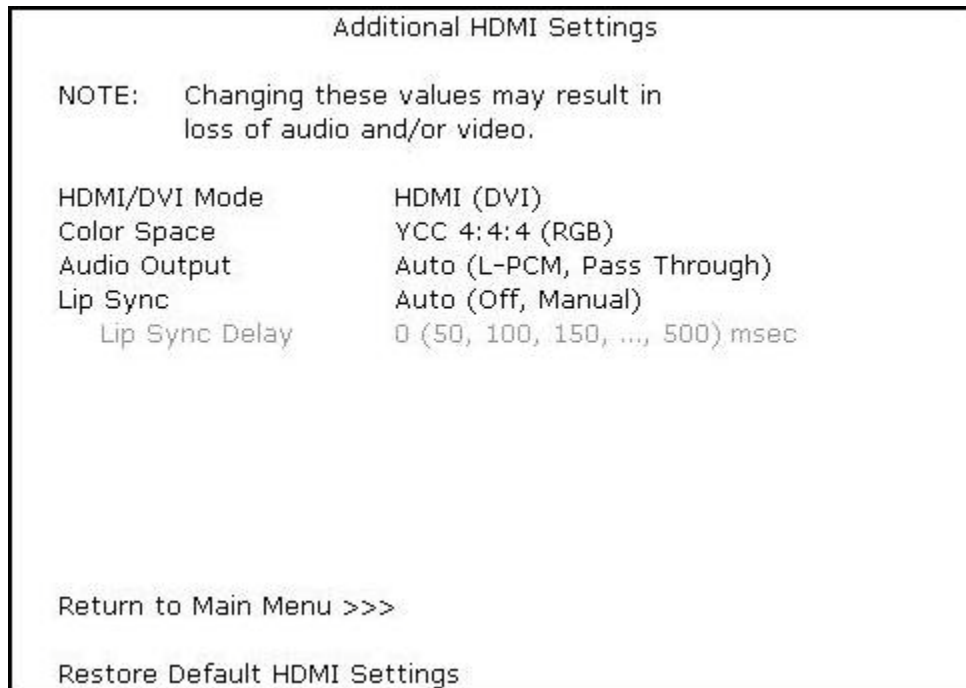


Setting	Description
<b>480p (Enhanced Definition)</b>	<p>Generates 480p video on both the HDMI and Component Video (YPbPr) outputs if the program is broadcast in 480p format. The DCX3510-M can also convert any other broadcast format to the 480p video format.</p> <p>480p is an enhanced-definition video image with 720 x 480 pixels, progressive scanning, and a frame rate of 60 frames per second.</p>
<b>480i (Standard Definition)</b>	<p>If this option is selected, the DCX3510-M generates 480i video on both the HDMI and Component Video (YPbPr) outputs if the program is broadcast in 480i format. The DCX3510-M can also convert any other broadcast format to the 480i video format.</p> <p>480i is a standard-definition video image with 720 x 480 pixels, interlaced scanning, and a frame rate of 30 frames per second.</p>
<b>Restore Default Native Settings</b>	<p>Selecting this option will restore the checklist of video formats to its default configuration. Use this option if audio and/or video has been lost after adjusting these settings from their default values.</p> <p>If you are the HDMI connection to your television, the checklist will be automatically customized according to the supported formats reported by the television.</p> <p>If you are using the Component Video (YPbPr) connection to your television, the checklist will have only the <b>1080i</b> and <b>480i</b> formats selected.</p>
<b>Return to Main Menu</b>	<p>Selecting this option will return you to the User Settings Menu main screen.</p>



## Additional HDMI Settings Screen

The Additional HDMI Settings menu configures advanced options that affect the operation of the DCX3510-M with other HDMI and DVI display devices. Adjustable options include display mode, color space, audio output mode, and audio lip sync delay.



**Figure 16: Additional HDMI Settings Screen**



**Table 6: Additional HDMI Settings Field Descriptions**

Setting	Description
<b>HDMI/DVI Mode</b>	<p>Allows you to optimize the HDMI output to work with both DVI-equipped televisions and HDMI-equipped televisions. HDMI is the default setting.</p> <ul style="list-style-type: none"> <li>• <b>HDMI</b>—Optimized to work with an HDMI television or home theater receiver.</li> <li>• <b>DVI</b>—Optimized to work with a DVI television or display device (connected via an HDMI-to-DVI adapter).</li> </ul>
<b>Color Space</b>	<p>Allows you to adjust the color space used by the DCX3510-M to generate the video signals on the HDMI output. YCC 4:4:4 is the default setting.</p> <ul style="list-style-type: none"> <li>• <b>YCC 4:4:4</b>—Generates video signals within the YCC color space.</li> <li>• <b>RGB</b>—Generates video signals within the RGB color space.</li> </ul> <p><i>Note: Adjusting these settings could result in a loss of video. Only a professional installer or someone with a good working knowledge of the color spaces supported by the TV should change this setting.</i></p>
<b>Audio Output</b>	<p>Allows you to specify the digital audio format delivered over the HDMI output by the DCX3510-M. Options include <b>Auto</b>, <b>L-PCM</b>, and <b>Pass Through</b>. Auto option is the default setting.</p> <ul style="list-style-type: none"> <li>• <b>Auto</b>—Provides the digital audio format specified by the connected device (TV or home theater receiver) when that device was first connected to the DCX3510-M.</li> <li>• <b>L-PCM</b>—Provides all audio in the Linear Pulse Code Modulation digital audio format. The L-PCM format is widely supported by most HDMI televisions and home theater receivers.</li> <li>• <b>Pass Through</b>—Provides the same digital audio format on the HDMI output as is provided with the program being viewed at that time. For example, if the program has a Dolby Digital soundtrack, the DCX3510-M passes the Dolby Digital audio to the HDMI output. This option is most useful when connecting the DCX3510-M to a home theater receiver that has HDMI switching capability.</li> </ul> <p><i>Note: Adjusting these settings could result in a loss of audio. Only a professional installer or someone with a good working knowledge of the digital audio formats supported by the TV and/or home theater receiver should change this setting.</i></p>
<b>Lip Sync</b>	<p>Allows you to adjust the amount of time the audio signal is delayed with respect to the video signal on the HDMI output. Some HDMI televisions and home theater receivers add an extra delay to the video signal during processing which can produce an effect where the audio noticeably “leads” the video.</p> <p>By default, this option is set to <b>Auto</b>. The options are used as follows:</p> <ul style="list-style-type: none"> <li>• <b>Auto</b>—The DCX3510-M automatically delays the audio signal on the HDMI output by the amount of time requested by the connected HDMI device.</li> <li>• <b>Manual</b>—The DCX3510-M delays the audio signal on the HDMI output by the amount of time selected for the <b>Lip Sync Delay</b> setting.</li> <li>• <b>Off</b>—The DCX3510-M will not delay the audio signal on the HDMI output.</li> </ul>

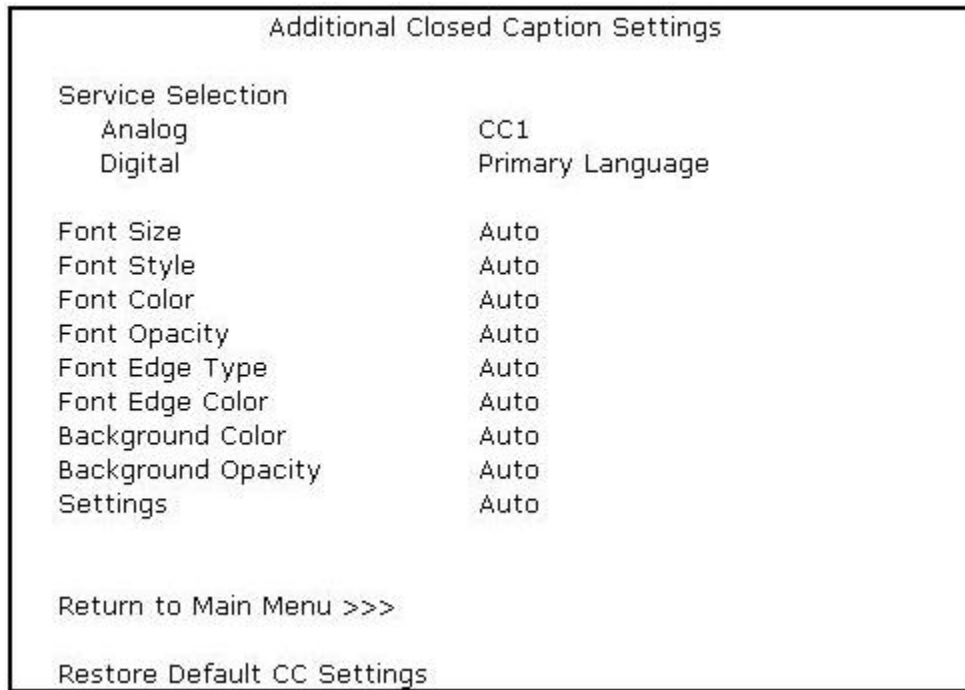


Setting	Description
<b>Lip Sync Delay</b>	<p>Available when the Lip Sync option has been set to Manual.</p> <p>The Lip Sync Delay setting can be adjusted between 0 milliseconds and 500 milliseconds in 50 millisecond increments.</p> <p>If the Lip Sync option has been set to either Auto or Off, this option is disabled and can't be selected in the menu.</p> <p>Use this option to adjust the HDMI audio delay if you notice that the video image routinely seems to be "behind" the audio soundtrack when using your HDMI device.</p>
<b>Return To Main Menu</b>	<p>Returns you to the User Settings Menu main screen.</p>
<b>Restore Default HDMI Settings</b>	<p>Restores all of the settings on this screen (HDMI/DVI Mode, Color Space, Audio Output, and Lip Sync) to their default values.</p> <p>Use this option if you lose audio and/or video after changing these settings from their default values.</p>



## Additional Closed Caption Settings Screen

The Additional Closed Caption Settings menu adjusts the various display options for closed caption legibility. Customizable options include font size, font style, font color, and font opacity. You may also choose to view different closed caption services if these are included within the broadcast program.



**Figure 17: Additional Closed Caption Settings Menu Screen**

**Table 7: Additional Closed Caption Settings Field Descriptions**

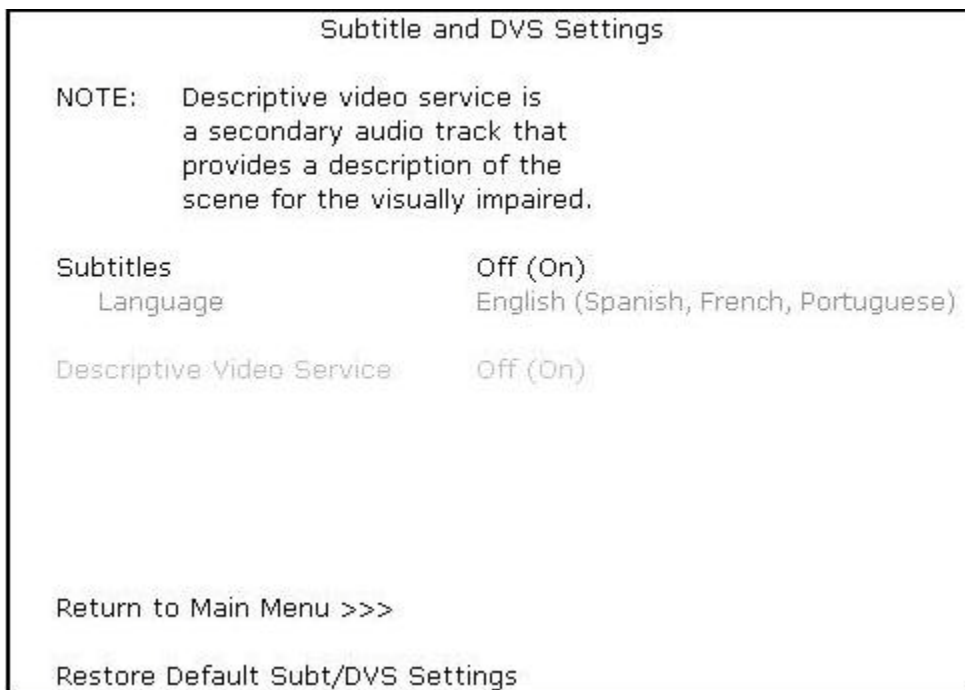
Setting	Description
<b>Service Selection</b>	<p>Sets the service used by the DCX3510-M to render (draw) the closed captions:</p> <ul style="list-style-type: none"> <li>• <b>Analog</b>—Affects closed captions for analog and digital standard definition services. Available options are: CC1, CC2, CC3, CC4, T1, T2, T3, or T4. The default setting is CC1.</li> <li>• <b>Digital</b>—Affects closed captions for digital enhanced definition and high definition services. Available options are: Primary Language, Secondary Language, 3, 4, 5, or 6. The default setting is Primary Language.</li> </ul>
<b>Font Size</b>	Sets the font size used for rendering (drawing) closed captions. The default setting is Auto. Available options include: Auto, Standard, Large, or Small.
<b>Font Style</b>	Sets the font style used for rendering (drawing) closed captions. The default setting is Auto. Available options include: Auto, Mono Serif, Proportion Serif, Mono No Serif, Proportion No Serif, Casual, Cursive, or Small Capitals.
<b>Font Color</b>	Sets the font color used for rendering (drawing) closed captions. The default setting is Auto. Available options include: Auto, White, Black, Red, Green, Blue, Yellow, Magenta, or Cyan.
<b>Font Opacity</b>	Sets the opacity used for rendering (drawing) closed captions. The default setting is Auto. Available options include: Auto, Transparent, Translucent, Solid, or Flashing.
<b>Font Edge Type</b>	Sets the edge appearance used for rendering (drawing) closed captions. Available options include: Auto, None, Raised, Depressed, Uniform, Left Shadowed, or Right Shadowed. The default setting is Auto.
<b>Font Edge Color</b>	Sets the edge color used for rendering (drawing) closed captions. Available options include: Auto, White, Black, Red, Green, Blue, Yellow, Magenta, or Cyan. The default setting is Auto.
<b>Background Color</b>	Sets the background color used for rendering (drawing) closed captions. The default setting is Auto. Available options include: Auto, White, Black, Red, Green, Blue, Yellow, Magenta, or Cyan.
<b>Background Opacity</b>	Sets the background opacity used for rendering (drawing) closed captions. The default setting is Auto. Available options include: Auto, Transparent, Translucent, Solid, or Flashing.
<b>Settings</b>	Sets the default settings for closed captions (Auto) or restores the settings you had previously configured (User) allowing you to easily change the closed caption settings between their default settings and your customized settings. The default setting is Auto. Available options include: Auto or User.
<b>Return To Main Menu</b>	Returns you to the User Settings Menu main screen.
<b>Restore Default CC Settings</b>	To reset all of the Additional Closed Caption settings to their default values, navigate to this option and press the ► key.



## Subtitle and DVS Settings Screen

The Subtitle and DVS Settings menu customizes the language and appearance of subtitles and turns the descriptive video service feature on and off. Subtitles allow a viewer to watch television programs and movies that contain dialogue that is not in the viewer's native language. Subtitles are not included in many television programs (unlike closed captions).

A descriptive video service (DVS) is a special secondary audio track that is included with many television programs and is intended to assist the visually impaired. The DVS audio track provides a verbal description of each scene along with the program's normal dialogue.



**Figure 18: Subtitle and DVS Settings Menu Screen**

**Table 8: Subtitle and DVS Settings Field Descriptions**

Setting	Description
<b>Subtitles</b>	<p>The default setting is <b>Off</b>.</p> <ul style="list-style-type: none"> <li>• <b>Off</b>—Subtitles are not rendered (drawn) by the DCX3510-M.</li> <li>• <b>On</b>—Subtitles are rendered (drawn) by the DCX3510-M if they are included in the program and in the language specified by the Language setting.</li> </ul> <p>When the Subtitles option is set to On, Language can be selected from the menu.</p>
<b>Language</b>	<p>The Language setting is only available when the Subtitles option is set to On. Otherwise, this setting is disabled and can't be selected in the menu.</p> <p>The default language selection is <b>English</b>.</p> <ul style="list-style-type: none"> <li>• <b>English</b>—Renders (draws) subtitles in English if they are included in the program.</li> <li>• <b>Spanish</b>—Renders (draws) subtitles in Spanish if they are included in the program.</li> <li>• <b>French</b>—Renders (draws) subtitles in French if they are included in the program.</li> <li>• <b>Portuguese</b>—Renders (draws) subtitles in Portuguese if they are included in the program.</li> </ul> <p><i>Note: The DCX3510-M is not capable of translating subtitles from one language to another. For example, if French subtitles are included with the program, the DCX3510-M cannot translate them to into Portuguese if the Language option has been set to Portuguese. The DCX3510-M can only display subtitles in the language(s) that have been included within the program.</i></p>
<b>Descriptive Video Service</b>	<p>The default setting is Off.</p> <ul style="list-style-type: none"> <li>• <b>Off</b>—The DVS audio track is not played by the DCX3510-M.</li> <li>• <b>On</b>—The DVS audio track is played by the DCX3510-M if it is included in the program.</li> </ul> <p><i>Note: If the DVS setting is disabled and can't be selected from the menu, the software installed on the DCX3510-M can't support the DVS feature.</i></p>
<b>Return To Main Menu</b>	Returns you to the User Settings Menu main screen.
<b>Restore Default Subt/DVS Settings</b>	To reset all of the Subtitle and DVS settings to their default values, navigate to this option and press the ► key.

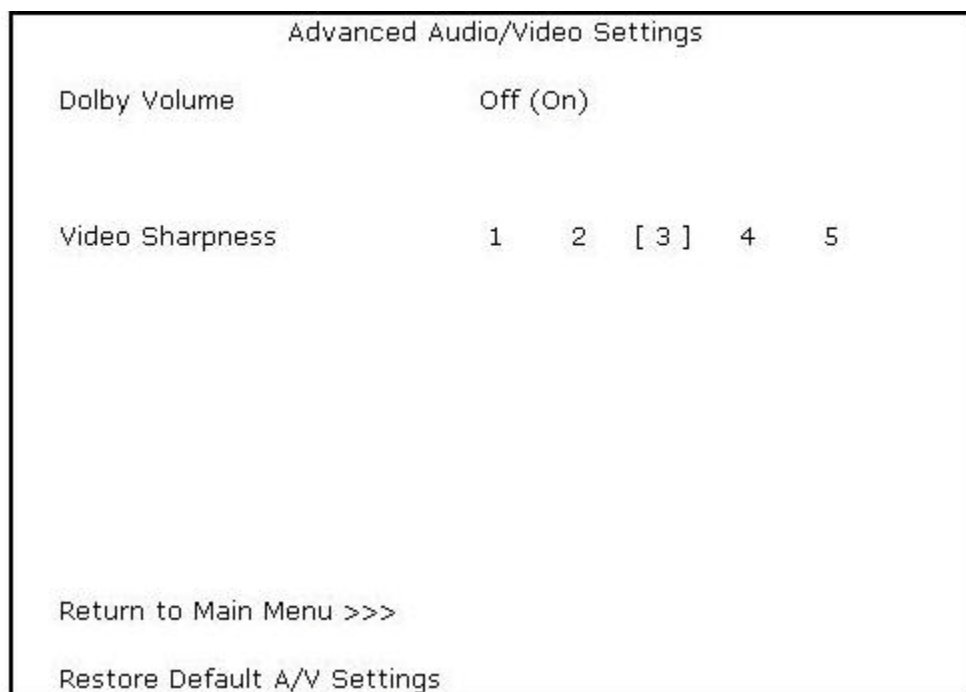


## Advanced Audio/Video Settings Screen

The Advanced Audio/Video Settings menu customizes several advanced audio and video features of the DCX3510-M, most notably the Dolby Volume feature and the Video Sharpness feature.

The Dolby Volume feature provides volume normalization across channels, programs, and commercials. Normalization is a process where the different volume levels across channels, programs, and commercials are adjusted to the same approximate output volume. As a result, sudden volume changes are reduced and the overall volume output of the DCX3510-M is more consistent.

The Video Sharpness feature softens or sharpens Standard Definition (SD) programs when viewed on either the HDMI or Component Video (YPbPr) outputs. When SD programs are viewed on a large screen television, picture quality can suffer because noise and other imperfections in the picture can be magnified on the large display. The Video Sharpness feature can be used to soften the picture and reduce the appearance of these imperfections.



**Figure 19: Advanced Audio/Video Settings Menu Screen**

**Table 9: Advanced Audio/Video Settings Field Descriptions**

Setting	Description
<b>Dolby Volume</b>	<p>The default setting is Off.</p> <ul style="list-style-type: none"> <li>• <b>Off</b>—Output volume may fluctuate during commercials or when changing channels.</li> <li>• <b>On</b>—Maintains a more consistent output volume regardless of the channel or program being viewed.</li> </ul>
<b>Video Sharpness</b>	<p>The Video Sharpness setting allows you to adjust the picture sharpness when viewing a standard definition (SD) program on the DCX3510-M.</p> <p>The Video Sharpness setting affects the HDMI and Component Video (YPbPr) outputs. Level of 3 is the default value.</p> <p>The DCX3510-M supports five distinct levels of analog video picture sharpness. A value of 1 corresponds to a “softer” picture while a value of 5 corresponds to a “sharper” picture.</p> <p>The best sharpness setting depends upon the video connection being used, the display quality of the TV, and your own personal preference.</p>
<b>Return To Main Menu</b>	Returns you to the User Settings Menu main screen.
<b>Restore Default A/V Settings</b>	To reset all of the Advanced Audio/Video settings to their default values, navigate to this option and press the ► key.

## Graphics Overlaying the Video

The DCX3510-M can generate graphics that overlay the video programming or fill the entire television screen. Common examples include on-screen menus (such as the User Setting menu), closed captions, and IPG. The DCX3510-M overlays these graphics whenever you open a menu, enable closed captions, or scroll through a program grid. On-screen graphics are available for all DCX3510-M video outputs except IEEE-1394.





# 5

## Diagnostics

Diagnostics are displayed on the on-screen display (OSD) and front-panel display. They confirm proper installation, including:

- Checking error states and signal integrity
- Identifying the cable terminal on the network
- Verifying communications with the headend

For the diagnostics described in this section:

- All indicators are in decimal notation, unless otherwise noted.
- All signal-level and quality indicators use a 1% to 100% scale, unless otherwise noted.
- All sample displays are illustrative; actual data may differ from the examples.

### Using the Diagnostics

To use the diagnostics:

1. Ensure that the DCX3510-M is installed with the Thin Client software and that it is connected to an AC outlet.
2. Ensure the set-top is powered on.
3. Press power to put the set-top in stand-by mode. Within two (2) seconds, press select on the remote control to enable the diagnostic mode.
4. The Diagnostics main menu is displayed on the OSD, and d01 is displayed on the front panel:



You can use the following keys on the remote control to navigate the diagnostics menus:

- Press channel ▲, channel ▼, cursor ▲, or cursor ▼ to select d01 through E.
- Press cursor ◀, cursor ▶, select or enter to execute the selected diagnostic.
- Select E from the main menu or press power to exit.



```
DIAGNOSTICS
> d01 GENERAL STATUS
d02 PURCHASE/POLL STATUS
d03 OOB STATUS
d04 INBAND STATUS
d05 UNIT ADDRESS/SECURITY
d06 CURRENT CHANNEL STATUS
d07 UPSTREAM STATUS
d08 CODE MODULES
d09 MEMORY CONFIG
d10 AUDIO/VIDEO STATUS
d11 INTERFACE/PORT STATUS
d12 USER SETTING STATUS
d13 DVR/HDD STATUS
d14 DOCSIS STATUS
d15 APPLICATION SPECIFIC INFORMATION
d16 INTERACTIVE STATUS
d17 CONNECTED HOME
d18 KEYPAD/LED
E EXIT
```

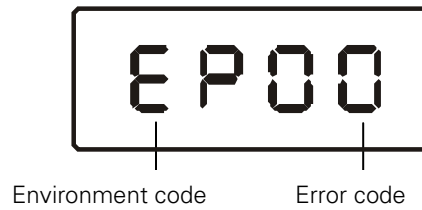
**Figure 20: Diagnostic Main Menu Screen**

## General Status

This diagnostic displays system status information on the OSD and front panel. The information is updated each time the diagnostic is displayed.

```
GENERAL STATUS
ERROR:          EPO0 CONNECTED DES
PLATFORM ID:    0x0812
MAPPED PLATFORMID: 0x0812
FAMILY ID:      0x001D
MODEL ID:       0xEC04
REMOD CHANNEL:  03
SETTOP LOCAL TIME: Nov 04 2010 14:20:15
DST ACTIVE:     NO
TIME ZONE:      GMT-05:00
DST ENTRY TIME: Apr 03 2011 07:00:00 GMT
DST EXIT TIME:  Oct 30 2011 06:00:00 GMT
CURRENT GPS TIME: Nov 04 2010 19:20:15
COUNTRY CODE:   USA, 1, UNITED STATES
TOTAL RUN TIME: 4H 50M
STANDBY TIME %: 1%
LOW POWER TIME %: 0%
```

**Figure 21: General Status Diagnostic Screen**



**Figure 22: Example General Status display (no error)**

**Table 10: General Status Diagnostic Field Descriptions**

Field	Description																										
<b>Error</b>	Error codes display on the LED and OSD when an error occurs. If multiple errors occur, the last recorded error is displayed:																										
	<table border="1"> <thead> <tr> <th>Error Code</th> <th>Description</th> </tr> </thead> <tbody> <tr> <td>EP00</td> <td>No error</td> </tr> <tr> <td>EP01</td> <td>Not connected</td> </tr> <tr> <td>EP03</td> <td>DRAM error</td> </tr> <tr> <td>EP04</td> <td>SRAM error</td> </tr> <tr> <td>EP07</td> <td>ROM verification failure</td> </tr> <tr> <td>EP08</td> <td>RAM test failure</td> </tr> <tr> <td>EP09</td> <td>Battery test failure</td> </tr> <tr> <td>EP11</td> <td>Invalid unit address</td> </tr> <tr> <td>EP12</td> <td>Power on self test failure</td> </tr> <tr> <td>EP14</td> <td>GITV startup failure</td> </tr> <tr> <td>EP15</td> <td>TSI structure corrupt</td> </tr> <tr> <td>EP18</td> <td>Driver initialization failure</td> </tr> </tbody> </table>	Error Code	Description	EP00	No error	EP01	Not connected	EP03	DRAM error	EP04	SRAM error	EP07	ROM verification failure	EP08	RAM test failure	EP09	Battery test failure	EP11	Invalid unit address	EP12	Power on self test failure	EP14	GITV startup failure	EP15	TSI structure corrupt	EP18	Driver initialization failure
Error Code	Description																										
EP00	No error																										
EP01	Not connected																										
EP03	DRAM error																										
EP04	SRAM error																										
EP07	ROM verification failure																										
EP08	RAM test failure																										
EP09	Battery test failure																										
EP11	Invalid unit address																										
EP12	Power on self test failure																										
EP14	GITV startup failure																										
EP15	TSI structure corrupt																										
EP18	Driver initialization failure																										
<b>Connected State</b>	A DCX-operations connect or disconnect message determines whether the DCX3510-M is CONNECTED or DISCONNECTED.																										
<b>Platform ID</b>	A unique 16-bit hexadecimal number that identifies the platform image (also called the ROM ID).																										
<b>Family ID</b>	The manufacturer and product family, in hexadecimal.																										
<b>Model ID</b>	The model, in hexadecimal.																										



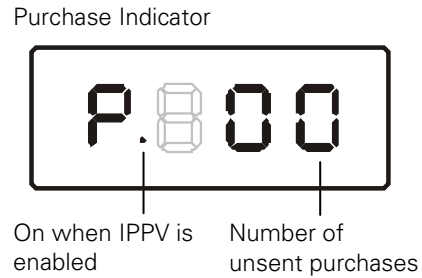
Field	Description
<b>Remod Chan</b>	N/A
<b>Set-top Local Time</b>	The current time setting on set-top.
<b>DST Active</b>	Daylight Saving Time. Yes indicates the DST is active. No indicates the DST is disabled.
<b>Time Zone</b>	Time Zone is selected on the set-top.
<b>DST Entry Time</b>	The Date and Time the set-top will begin Daylight Savings Time.
<b>DST Exit Time</b>	The Date and Time the set-top will end Daylight Savings Time.
<b>Current GPS Time</b>	The current OOB time displayed in global positioning system (GPS) seconds from Jan 6, 1980. It is displayed in Greenwich Mean Time (GMT).
<b>Country Code</b>	Country code, if configured by the controller
<b>Total Run Time</b>	Total Run time in hours and minutes since last reset or power cycle
<b>Standby Time %</b>	Percent of time the set-top is in standby mode
<b>Low Power Time %</b>	Percent of time the set-top is in Low Power mode, if power saving mode is enabled.

## Purchase Status

This diagnostic displays the status of subscriber event purchases on the OSD and front panel. The OSD and front panel displays are updated each time this diagnostic is viewed:

PURCHASE/POLL STATUS	
PURCHASES:	
UNSENT:	00
UNACK:	00
LAST SEQ NUM:	0000
LAST RB TIME:	N/A
IPPV STATUS: DISABLED	
LAST POLL STATUS	
PREP CMD:	0 N/A
PREP ACK:	0 N/A
POLL REQ:	0 N/A
POLL ACK:	0 N/A
STACK LIMIT:	00000010
SHOW COUNT:	00000000
CREDIT TOTAL:	0000010000
DEBIT TOTAL:	0000000000

**Figure 23: Purchase Status Diagnostic Screen**



**Figure 24: Front panel display for Purchase Status diagnostic**

**Table 11: Purchase Status Diagnostic Field Descriptions**

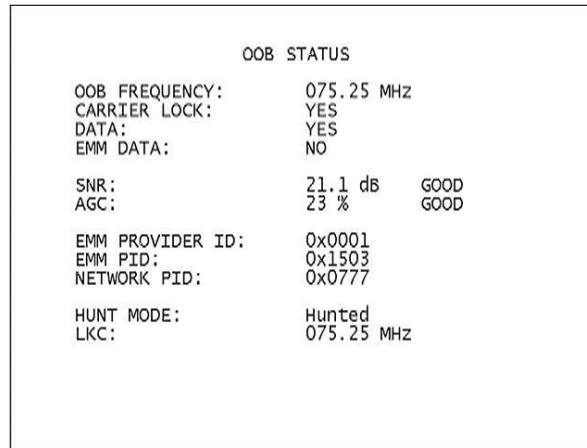
Field	Description
<b>Unsent</b>	The number of purchases in the DCX3510-M remaining to be polled. It can be an integer from 0 to 63.
<b>Unack</b>	The number of reports that have not been acknowledged by the controller. It is an integer.
<b>Last Seq Num</b>	The last acknowledged sequence number of a purchase sent by the controller. It is a 16-bit, unsigned hexadecimal number.
<b>Last RB Time</b>	The last time the DCX3510-M attempted to report back purchases to the controller, in GPS seconds.
<b>IPPV Status</b>	If IPPV is enabled, the IPPV status indicator is on. If IPPV is disabled, the IPPV status indicator is off.
<b>Prep CMD</b>	“Last Prepare for Poll Command” sequence number and time of the last prepare for poll request command that was sent by the controller. Note that each requesting process maintains an independent sequence of poll requests to uniquely identify the poll responses.
<b>Prep ACK</b>	“Last Prepare for Poll Acknowledge” sequence number and time of the last Report Purchase request sent by the controller.
<b>Poll Request</b>	Sequence number and time of the last send poll buffer command that was sent by the controller.
<b>Poll Acknowledge</b>	Sequence number and time of the last Poll Acknowledge message sent by the controller.
<b>Stack Unit</b>	Unit used in purchase processing.
<b>Show Count</b>	Count used in purchase processing.
<b>Credit Total</b>	Credit used for purchase processing.



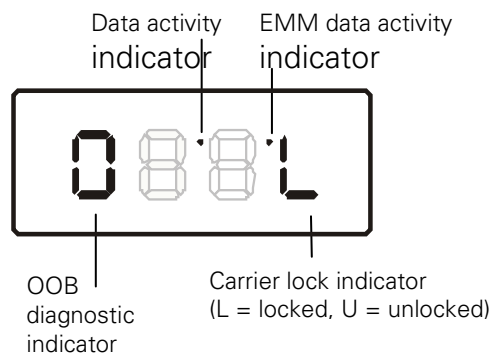
Field	Description
<b>Debit Total</b>	Debit used for purchase processing.

## Out-Of-Band (OOB) Status

This diagnostic indicates the out-of-band control channel status. The information is updated every five seconds.



**Figure 25: OOB Status Diagnostic Screen**



**Figure 26: Front panel display for the OOB diagnostic**

**Table 12: OOB Diagnostic Field Descriptions**

Field	Description									
<b>OOB Frequency</b>	Indicates the OOB tuner center frequency, from 70 to 130 MHz.									
<b>Carrier Lock</b>	Indicates whether the OOB receiver is locked to the carrier:									
	<table border="1"> <thead> <tr> <th>OSD</th> <th>Front panel</th> <th>Description</th> </tr> </thead> <tbody> <tr> <td>YES</td> <td>L</td> <td>Carrier locked</td> </tr> <tr> <td>NO</td> <td>U</td> <td>Carrier unlocked</td> </tr> </tbody> </table>	OSD	Front panel	Description	YES	L	Carrier locked	NO	U	Carrier unlocked
OSD	Front panel	Description								
YES	L	Carrier locked								
NO	U	Carrier unlocked								
<b>Data</b>	Indicates whether data is being carried by the OOB and EMM traffic, which is tracked separately:									
	<table border="1"> <thead> <tr> <th>OSD</th> <th>Front panel</th> <th>Description</th> </tr> </thead> <tbody> <tr> <td>YES</td> <td>On</td> <td>OOB data detected within the last 5 seconds</td> </tr> <tr> <td>NO</td> <td>Off</td> <td>OOB data not detected within the last 5 seconds</td> </tr> </tbody> </table>	OSD	Front panel	Description	YES	On	OOB data detected within the last 5 seconds	NO	Off	OOB data not detected within the last 5 seconds
OSD	Front panel	Description								
YES	On	OOB data detected within the last 5 seconds								
NO	Off	OOB data not detected within the last 5 seconds								
<b>EMM Data</b>	Indicates whether EMM data is being carried on the OOB stream:									
	<table border="1"> <thead> <tr> <th>OSD</th> <th>Front panel</th> <th>Description</th> </tr> </thead> <tbody> <tr> <td>YES</td> <td>On</td> <td>EMM data detected within the last 5 seconds</td> </tr> <tr> <td>NO</td> <td>Off</td> <td>EMM data not detected within the last 5 seconds</td> </tr> </tbody> </table>	OSD	Front panel	Description	YES	On	EMM data detected within the last 5 seconds	NO	Off	EMM data not detected within the last 5 seconds
OSD	Front panel	Description								
YES	On	EMM data detected within the last 5 seconds								
NO	Off	EMM data not detected within the last 5 seconds								
<b>SNR</b>	<p>When carrier lock has been established, displays an estimate of the carrier signal-to-noise ratio in dB, with an explanation:</p> <p>GOOD — Good value</p> <p>FAIR — Marginal signal level, check the signal</p> <p>POOR — Unusable signal</p> <p>INVALID — Invalid AGC value</p>									
<b>AGC</b>	<p>When carrier lock has been established, displays an estimate of the AGC as a percentage, with an explanation:</p> <p>GOOD — Good value</p> <p>FAIR — Marginal signal level, check the signal</p> <p>POOR — Unusable signal</p> <p>INVALID — Invalid AGC value</p>									
<b>EMM Provider ID</b>	Displays the conditional access stream for the DCX3510-M, in hexadecimal.									
<b>EMM PID</b>	Displays the packet identifier (PID) stream the DCX3510-M tunes to for EMM data, in									



Field	Description
	hexadecimal.
<b>Network PID</b>	Displays the network PID to which the DCX3510-M is tuned to receive network messages, in hexadecimal.
<b>Hunt Mode</b>	The hunt mode includes Hunted, None, Round Robin (RR), Search (SRCH), Fixed Frequency (FIX), or EMM Provider ID (EMM).
<b>LKC</b>	<p>The last known carrier is the last valid OOB frequency displayed in MHz and ranges from 70 to 130 MHz, with the specific values of: 75.25, 104.20, 72.75, 92.25, 98.25, 107.25, 107.40, 110.25, 116.25, and 103.75.</p> <p>LKC will remain blank during hunting if a valid carrier has not been found, and will be populated once a valid OOB is found.</p>

## Agile OOB Tuner Hunting

Manually select an OOB frequency by pressing the Menu button while in the OOB Status diagnostics screen. To exit this mode, press the Menu button a second time, or press the Power button.

If the set-top is in the process of hunting for an OOB frequency, control of frequency selection is suspended, i.e., it is not possible to press the Menu button on the OOB status screen and display MAN FREQ when the set-top is hunting.

### Summary of Manual Selection of the OOB Frequency

The manual override frequency capability is only displayed if the box is not currently hunting and the operator presses the MENU key while OOB OSD diagnostics are displayed. The MAN Freq displays the LKC and allows the operator to select (via scroll up/down) a specific frequency to check if a valid OOB is on that specific frequency. The MAN Freq parameter is the OOB frequency selected in the frequency selection mode and displayed in MHz, with the specific values of 75.25, 104.20, 72.75, 92.25, 98.25, 107.25, 107.40, 110.25, 116.25, and 103.75.

1. When in the OOB Receiver Status Diagnostic, press the MENU button to enter the frequency selection mode. The Front Panel displays the frequency of the last known carrier. The OSD displays a new "MAN FREQ" line at the bottom of the screen, which indicates the last known carrier frequency. At this point, if desired, the frequency change mode can be exited by pressing the MENU key a second time.
2. Use the UP/DOWN channel or cursor keys to scroll through all 10 frequencies until the desired new OOB frequency is found. The new frequency selections appear on the Front Panel and on the MAN FREQ line of the OSD. When the last known frequency is selected, a dot appears in the middle-upper part of the Front Panel.
3. When the desired new frequency has been selected, press the SELECT key to start the search. The manual frequency search lasts up to 40 seconds. As the DCX3510-M searches, the frequency being searched for flashes on the Front Panel. On the OSD, the MAN FREQ line of text is cleared, the HUNT MODE displays FIX to indicate a search on a fixed frequency, and the OOB FREQ field changes to the frequency being searched for.





4. If the frequency is found with the proper EMM Provider ID, then the Front Panel displays the normal OOB receiver status. The OSD LKC field changes to display the new frequency.
5. If after 40 seconds the frequency search is not successful, the product performs a warm reset.
6. To abort a search without waiting the 40 seconds, the POWER key can be pressed to cause an immediate warm reset.

*Note: The Front Panel displays hunt after a cold reset from the front panel. This indicates that the product is in a Round Robin Hunt Mode. Hunt continues to be displayed until the proper stream is detected.*



## In-Band Status

This diagnostic displays the in-band status for the last attempted tuned channel. The information is updated every five seconds.

```

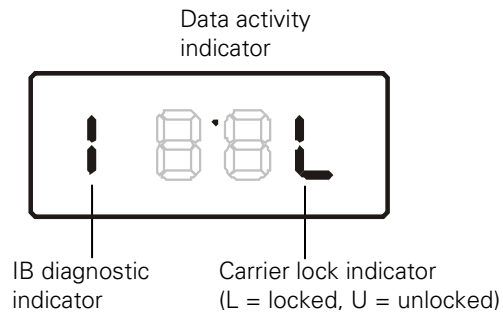
IN-BAND STATUS

IN-BAND TUNER 1
MODE:                256 QAM
CARRIER LOCK:      YES
PCR LOCK:           NO
DATA:               YES
FREQUENCY:          0651.000 MHz
SNR:                33.2 dB    GOOD
5 SECOND ERROR COUNTS:
UNCORRECTABLE: 0000    CORRECTABLE: 0000

IN-BAND TUNER 2
MODE:                256 QAM
CARRIER LOCK:      YES
PCR LOCK:           NO
DATA:               YES
FREQUENCY:          0567.000 MHz
SNR:                38.0 dB    GOOD
5 SECOND ERROR COUNTS:
UNCORRECTABLE: 0000    CORRECTABLE: 0000

```

**Figure 27: In-Band Status Diagnostic Screen**



**Figure 28: Front panel display for in band diagnostic**

**Table 13: In-Band Status Diagnostic Field Descriptions**

Field	Description									
<b>Mode</b>	The values displayed on the OSD are: 64 QAM — 64 QAM digital channel 256 QAM — 256 QAM digital channel									
<b>Carrier Lock</b>	Indicates whether the in-band receiver is locked to the carrier. If a digital carrier is not present, it indicates the carrier is not locked:									
	<table border="1"> <thead> <tr> <th>OSD</th> <th>Front panel</th> <th>Description</th> </tr> </thead> <tbody> <tr> <td>YES</td> <td>L</td> <td>Carrier locked</td> </tr> <tr> <td>NO</td> <td>U</td> <td>Carrier not locked</td> </tr> </tbody> </table>	OSD	Front panel	Description	YES	L	Carrier locked	NO	U	Carrier not locked
OSD	Front panel	Description								
YES	L	Carrier locked								
NO	U	Carrier not locked								
<b>PCR Lock</b>	Indicates whether the in-band receiver is locked to the current program clock reference for a digital video service on the specified tuner. If a digital carrier is not present, it indicates the PCR is not locked.									
<b>Data</b>	Indicates whether data is being carried on the in-band stream. The indicators cover all packet processors regardless of the stream they are monitoring:									
	<table border="1"> <thead> <tr> <th>OSD</th> <th>Front panel</th> <th>Description</th> </tr> </thead> <tbody> <tr> <td>YES</td> <td>On</td> <td>In-band data detected within the last 5 seconds</td> </tr> <tr> <td>NO</td> <td>Off</td> <td>In-band data not detected within the last 5 seconds</td> </tr> </tbody> </table>	OSD	Front panel	Description	YES	On	In-band data detected within the last 5 seconds	NO	Off	In-band data not detected within the last 5 seconds
OSD	Front panel	Description								
YES	On	In-band data detected within the last 5 seconds								
NO	Off	In-band data not detected within the last 5 seconds								
<b>Frequency</b>	The in-band frequency is center RF carrier frequency tuned for the digital service on the specified tuner. The frequency is displayed in MHz in xxxx.xxx format and ranges from 54 to 860 MHz.									
<b>SNR</b>	When carrier lock has been established, SNR displays an estimate of the carrier signal-to-noise ratio in dB, with an explanation: GOOD — Good value FAIR — Marginal signal level, check the signal POOR — Unusable signal INVALID — Invalid SNR value									
<b>5 Second Error Counts</b>	Indicates the number of correctable and uncorrectable digital multiplex errors, up to 9999. It is updated every five seconds and reset each time the DCX3510-M is power cycled or another digital multiplex is tuned. The maximum value displayed is 9999, even if there were more than 9999 errors.									



## Unit Address

This diagnostic displays the unit address of the CableCARD if inserted:

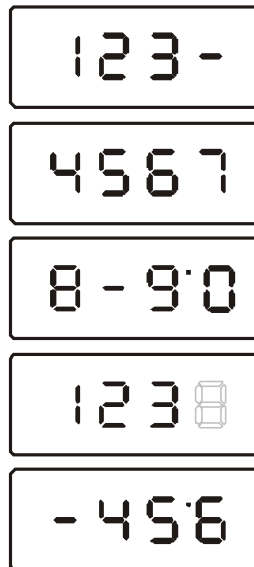
```
UNIT ADDRESS
TVPC INSTALLED:          NO
CableCARD INSERTED:     YES
UNIT ADDRESS: 000-00452-72214-047
OOB ADDRESSES:
NETWORK: 000-00000-00001-026
MULTICAST 16 FOR:      DATA

HOST SERIAL NO: M11041TD0017

HOST MAC ADDRESSES:
MAC-Address1: 3C 75 4A CA 9F 3B
MAC-Address2: 3C 75 4A AD D4 9B
MAC-Address3: 3C 75 4A FF FE AD D4 9E
MAC-Address4: 3C 75 4A AD D4 9D
MAC-Address5: 3C 75 4A AD D4 9C
MAC-Address6: 3C 75 4A AD D4 9F

Page 1 of 2                vvv scroll Down vvv
```

**Figure 29: Unit Address Diagnostic Screen**



**Figure 30: Front panel display of a unit address**

**Table 14: Unit Address Diagnostic Field Descriptions**

Field	Description
<b>TvPC Installed</b>	Indicates whether the TvPC renewable security system is installed: NO — TvPC is not installed (Note: the DCX3510-M does not include a TvPC slot).
<b>CableCARD Inserted</b>	YES — CableCARD is inserted. NO — CableCARD is not inserted.
<b>Unit Address</b>	A unique decimal number that indicates the unit address or physical address.
<b>OOB Addresses</b>	
<b>Network</b>	The DCX3510-M network address displayed in decimal format.
<b>Multicast 16 Address</b>	Specifies the stream to which the OOB multicast 16 addresses are assigned. The stream type and multicast 16 addresses cycle on the OSD every five seconds. The valid stream types nnnn are: Net — Network EMM — EMM SCC — SCC_ECM DnId — Download Data — Data Poll — Polling packet identifier (PID)  The 16-bit multicast address is displayed in 4-byte hexadecimal format. The multicast 16 addressed messages filter on a 16-bit multicast address. The user processor can define up to four multicast addresses in hardware, and any message matching one of the four is processed. Messages not matching the multicast address are discarded.
<b>Serial Number</b>	The Host Serial Number is displayed on the Unit Address diagnostic screen.
<b>MAC Addresses</b>	The MAC addresses are stored in protected flash and displayed in hexadecimal.



## Separable Security

This diagnostic displays information on the inserted M-CARD and CableCARD Interface with the DCX.

```

Separable Security      ^^^ scroll up ^^^
CARD Interface: GOOD
CableCARD ID: 000-045-272-214-3
Host ID: 044-026-972-168-2
Data ID: 274-297-661-92
Validation: VALID

Pairing Rpt Method:MMI
MSO Phone Number: UNKNOWN

CableCARD
Object Name: MCb1Card
Object Ver: 05.23
Manufacturer: 0x0000
HW Version: 0537971002
Boot Version: 03.25
2nd Version: 03.31
Serial Number: MA1038FAG326
MAC Address: 3C 75 4A D0 48 8D
Page 2 of 2
  
```

**Figure 31: Separable Security Diagnostic Screen**

**Table 15: Separable Security Diagnostic Field Descriptions**

Field	Description
<b>CARD Interface</b>	CableCARD Interface is a status indication of the interface between the Host and CableCARD. It will indicate "Good" if no errors are detected, "Error" if there is an error establishing the CableCARD interface, or "Unsupported CARD" if the inserted CableCARD is not an M-CARD.
<b>CableCARD ID</b>	The unique identifier provided by the CableCARD.
<b>Host ID</b>	The unique identifier in the Host Device Certificate.
<b>Data ID</b>	A value generated by the CableCARD for the Pairing report.
<b>Validation</b>	<ul style="list-style-type: none"> <li>• UNKNOWN if a Validation message was not received by the product.</li> <li>• VALID or INVALID as set by the Host Validation Message received from the headend.</li> <li>• BINDING if the CableCARD is busy with the binding authentication process.</li> <li>• NOT BOUND if Card validation status is not bound for CableCARD reasons.</li> <li>• HOST CERTIFICATE INVALID if the status is not bound because the Host Certificate was invalid.</li> <li>• HOST SIGN FAILED if status is not bound because of failure to verify Host's SIGN.</li> <li>• AUTH KEY FAILED if status is not bound because of failure to match AuthKey from the Host Device.</li> <li>• FAILED if binding failed for other reasons.</li> </ul>
<b>Pairing Rpt Method</b>	Set to MMI or Reportback as received by a message from the headend, or set to Unknown if the headend message was not received.



---

<b>MSO Phone Number</b>	MSO Phone Number as configured at the headend.
-------------------------	--

---

<b>CableCARD</b>	
------------------	--

---

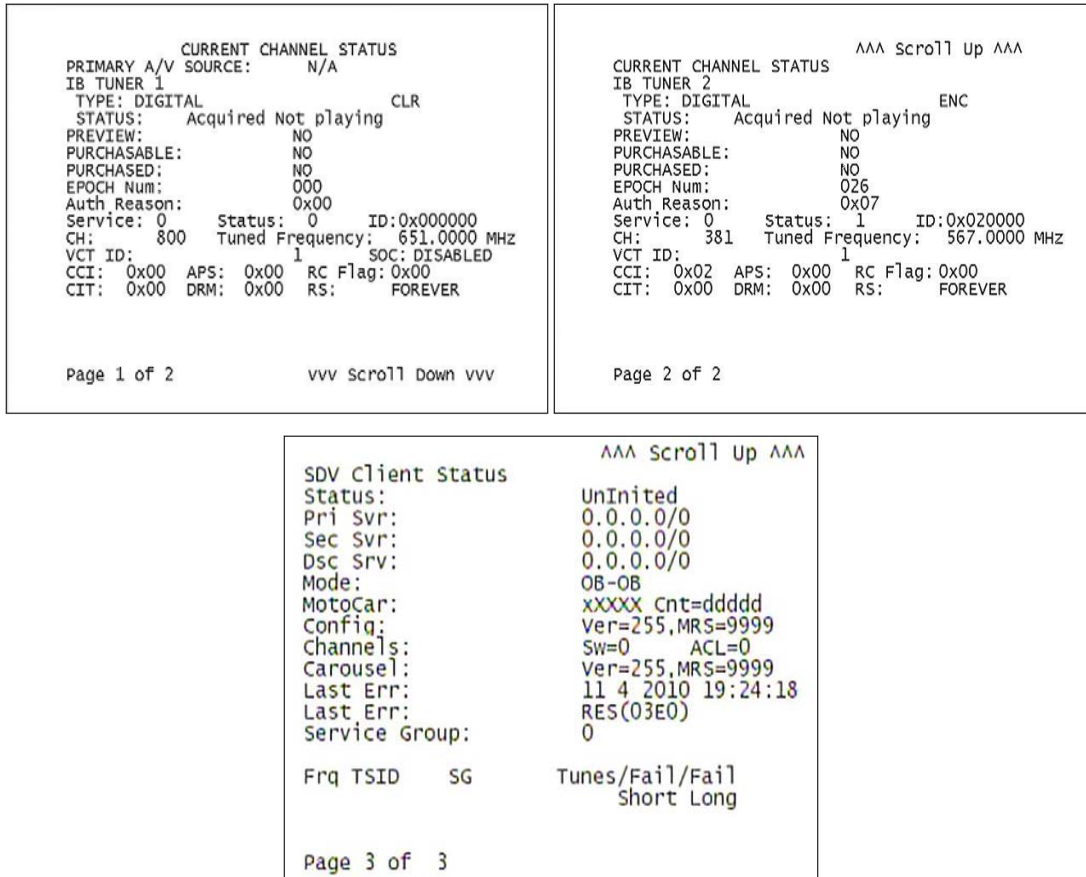
Object Name	Code object name executing on the CableCARD.
Object Ver.	Code object version executing on the CableCARD.
Manufacturer	CableCARD manufacturer.
HW Version	Version number provided by the CableCARD.
Boot Version	Version number provided by the CableCARD.
2nd Version	Version number provided by the CableCARD.
Serial Number	Serial number fo the CableCARD
MAC Address	MAC Address of the CableCARD.

---

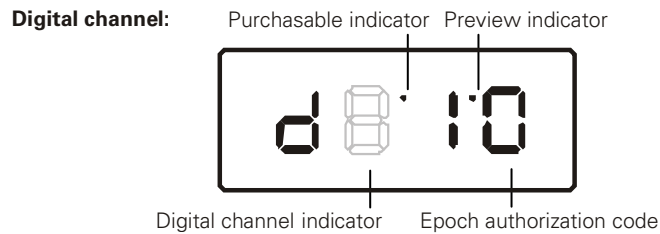


## Current Channel Status

This diagnostic displays a status of the last attempted channel you attempted to tune on the in-band stream. The channel type determines the status display.



**Figure 32: Current Channel Status Diagnostic Screens**



**Figure 33: Current Channel Status Front Panel Displays**



**Table 16: Current Channel Status Diagnostic Field Descriptions**

Field	Description		
<b>Type</b>	Indicates whether the channel is analog or digital.		
	<b>OSD</b>	<b>Front panel</b>	<b>Description</b>
	DIGITAL	d	Digital
<b>Status</b>	Indicates the current status of channel acquisition.		
	<b>OSD</b>	<b>Front panel</b>	<b>Description</b>
	Acquired		Service has been acquired and is playing, but stream components may not be locked yet if the service is digital. For an analog service, there are no stream components to lock, so this is the final status.
	Acquiring		Service is being reacquired.
	Not Acquired		Service has not been acquired due to a failure.
	Acquired and Locked		Digital service has been acquired, and all relevant stream components for the service are locked. If the service is purchasable, the stream components will not be locked until the service is purchased.
	Acquired Not Playing		Service has been partially acquired, but is not playing. For MPEG-2 services, this means that no components are selected.
<b>Preview</b>	Indicates whether the current program is in preview mode.		
<b>Purchasable</b>	Indicates whether the current program can be purchased for viewing.		
<b>Purchased</b>	Indicates whether the current program has been purchased.		
<b>EPOCH Num</b>	Number of authorization requests originating from DCX3510-M.		
<b>Auth Reason</b>	The current epoch authorization reason is displayed in the hexadecimal format 0xbb on the OSD and front panel.		
<b>Service</b>	Service number from the secure processor. It is a decimal value from 0 to 3.		
<b>Status</b>	Service status from the secure processor. It is a decimal value from 0 to 3.		
<b>ID</b>	Service ID from the secure processor. It is a hexadecimal value. First 2 bytes indicate a MPEG service number, and the last byte indicates another unique identifier.		
<b>CH</b>	Current Channel to which the set-top is tuned.		



Field	Description
<b>Tuned Frequency</b>	(Digital channels only) The center RF carrier frequency for the digital service. It can be From 54 to 860 MHz.
<b>VCT ID</b>	Virtual Channel Table ID
<b>SOC</b>	The Selectable Output control is enabled or disabled.
<b>CCI</b>	The copy control information: 00 — copy free 01 — no more copies 10 — copy once 11 — never copy N/A — the value is invalid or cannot be retrieved
<b>APS</b>	The Analog Protection System; for example, Macrovision: 00 — no Macrovision 11 — Type 3 Macrovision N/A — the value is invalid or cannot be retrieved
<b>RC Flag</b>	Displays whether the broadcast flag is present: 0 — no flag/not defined 1 — the flag is present/enabled N/A — the value is invalid or cannot be retrieved
<b>CIT</b>	The constrained image trigger, as delivered in the PRK or the Set DRM API: 1 — set 0 — not set N/A — the value is invalid or cannot be retrieved
<b>DRM</b>	The digital rights management valid flag bit: 1 — set 0 — not set N/A—the value is invalid or cannot be retrieved
<b>RS</b>	The retention state: Forever, 1 week, 2 days, 1 day, 12 hours, 6 hours, 3 hours, 90 minutes, or Not Defined N/A —value is invalid or cannot be retrieved
<b>SDV Client Status</b>	If Switched digital video is available, the following information is related to the SDV Client: <ul style="list-style-type: none"> <li>• Status of client</li> <li>• IP Address of primary switched video manager (SVM) server</li> <li>• IP Address of secondary switched video manager (SVM) server</li> <li>• IP Address of Auto Discovery server</li> <li>• SDV Mode</li> </ul>



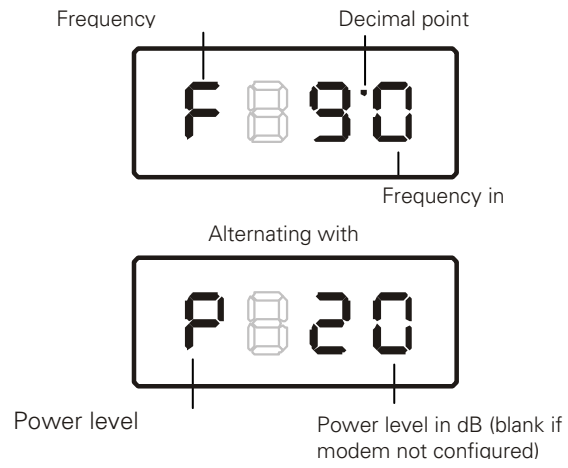
Field	Description
	<ul style="list-style-type: none"> <li>• MotoCar configuration and message count</li> <li>• Version number of the SDV configuration message and number of minutes since the version was last seen by the client</li> <li>• Configured switched channels (SW) followed by the number of channels in the Active Channel List (ACL).</li> <li>• Version number of the Mini Carousel message and the time it was last seen</li> <li>• Time and date of the last error recorded by the Client</li> <li>• Last error code</li> <li>• Service Group ID</li> <li>• SDV QAM diagnostic parameter table consisting of entries for attempted and successful SDV tunes and QAMs listed in the Auto Discover list. Table includes the QAM frequency, the TSID, ("*" if a TSID mismatch exists), Auto Discovery Indicator, if QAM is included in the Auto Discover List, Service group ID, count of successful tunes to switched services, count of short term tune failures over the last 24 hours, count of long term tune failures.</li> </ul>

## RF Modem (Upstream)

This diagnostic displays the RF modem status, if an RF modem is installed in the DCX3510-M. The information is updated each time the DCX3510-M displays this diagnostic.

RF MODEM	
STATUS:	CONFIGURED
CENTER FREQUENCY:	0008.096 MHZ
REQUESTED POWER LEVEL:	060 dB
ACTUAL POWER LEVEL:	INVALID
REPORT BACK ADDRESS:	0x000005

**Figure 34: RF Upstream Modem Diagnostic Screen**



**Figure 35: RF Upstream Modem Front Panel Display**

**Table 17: RF Upstream Modem Diagnostic Field Descriptions**

Field	Description
<b>Status</b>	CONFIGURED or NOT CONFIGURED.
<b>Center Frequency</b>	The RF modem center frequency is displayed on the OSD and front panel in MHz.
<b>Requested Power Level</b>	The value in dB assigned to the DCX3510-M during RF leveling (which is blank if it is not configured).
<b>Actual Power Level</b>	The power level is displayed in dB on the OSD and front panel or is blank if the power level has not been set.
<b>Report Back Address</b>	Displayed in 4-byte hexadecimal format, if configured.

## Code Modules

This diagnostic includes information about the firmware loaded in flash memory and all non-volatile code versions that are installed on the DCX3510-M. When the native suite is running, the diagnostics of the application operating system and all associated objects should be accessible.

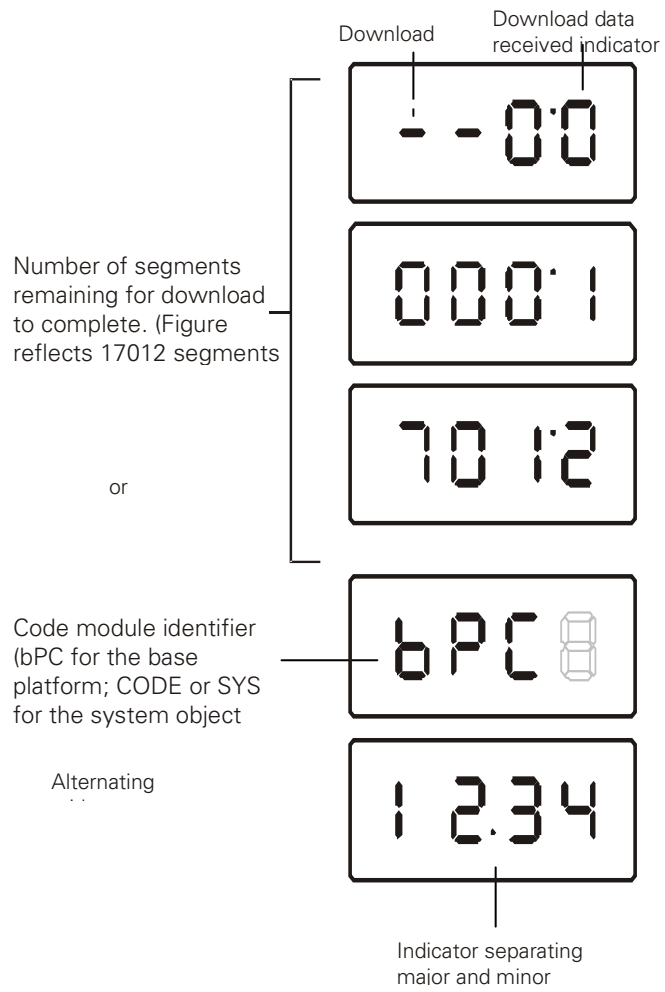
```

ASTB VALD   Lst:  26 Ver:   3
Boot Code:  09.10
Platform Built: Version: 22.12
              May 02 2008 16:28:49
              Processor: M01
Analog Secure Processor: N/A

Object  Ver  Status  ID  LO
TC_CS_CD 22.12 ENABLED 0897 0
Tv_Guide 75.59 ENABLED 07DA 1

```

**Figure 36: Code Modules Diagnostic Screen**



**Figure 37: Front Panel Display For Code Modules**

**Table 18: Code Modules Diagnostic Field Descriptions**

Field	Description																														
<b>Boot Code</b>	The boot code version in ASCII format.																														
<b>Platform Built</b>	The date platform software was built.																														
<b>Version</b>	The firmware version and build date in ASCII format.																														
<b>Processor</b>	The digital secure processor version in ASCII format.																														
<b>Analog Secure Processor</b>	The analog secure processor version in ASCII format.																														
<b>Downloadable Object Information Table</b>	Lists all objects loaded, or being loaded, onto the DCX3510-M in ASCII format. The information displayed for each object depends on the running environment. If a download is not in progress, the front panel displays the currently running environment and version number, as shown in Figure 4-9. On the front panel, bPC represents Thin Client code.																														
<b>Object</b>	The object name.																														
<b>Ver</b>	The object version.																														
<b>Status</b>	The object status, updated on the OSD and front panel every five seconds while you display the diagnostic:																														
	<table border="1"> <thead> <tr> <th>OSD</th> <th>Status</th> <th>Description</th> </tr> </thead> <tbody> <tr> <td>MEM ALLOC</td> <td>Allocated</td> <td>Memory for the object is allocated.</td> </tr> <tr> <td>LOADING</td> <td>Loading</td> <td>The Object is being loaded.</td> </tr> <tr> <td>STARTING</td> <td>Enabling</td> <td>The Object is being started (the constructor is running).</td> </tr> <tr> <td>ENABLED</td> <td>Enabled</td> <td>The Object is running.</td> </tr> <tr> <td>ENA-NOT RUN</td> <td>Enabled_Not_ Runnable</td> <td>The Object is enabled, but cannot run.</td> </tr> <tr> <td>STOPPING</td> <td>Disabling</td> <td>The Object is being stopped (the destructor is running).</td> </tr> <tr> <td>DISABLED</td> <td>Disabled</td> <td>The Object has been disabled.</td> </tr> <tr> <td>DIS-NOT RUN</td> <td>Disabled_Not_ Runnable</td> <td>The Object is disabled and cannot run.</td> </tr> <tr> <td>DELETING</td> <td>Deleting</td> <td>The Object is being deleted.</td> </tr> </tbody> </table>	OSD	Status	Description	MEM ALLOC	Allocated	Memory for the object is allocated.	LOADING	Loading	The Object is being loaded.	STARTING	Enabling	The Object is being started (the constructor is running).	ENABLED	Enabled	The Object is running.	ENA-NOT RUN	Enabled_Not_ Runnable	The Object is enabled, but cannot run.	STOPPING	Disabling	The Object is being stopped (the destructor is running).	DISABLED	Disabled	The Object has been disabled.	DIS-NOT RUN	Disabled_Not_ Runnable	The Object is disabled and cannot run.	DELETING	Deleting	The Object is being deleted.
OSD	Status	Description																													
MEM ALLOC	Allocated	Memory for the object is allocated.																													
LOADING	Loading	The Object is being loaded.																													
STARTING	Enabling	The Object is being started (the constructor is running).																													
ENABLED	Enabled	The Object is running.																													
ENA-NOT RUN	Enabled_Not_ Runnable	The Object is enabled, but cannot run.																													
STOPPING	Disabling	The Object is being stopped (the destructor is running).																													
DISABLED	Disabled	The Object has been disabled.																													
DIS-NOT RUN	Disabled_Not_ Runnable	The Object is disabled and cannot run.																													
DELETING	Deleting	The Object is being deleted.																													



Field	Description		
	POSTPONED	Postponed	The Object cannot run on the current system; it will be enabled during the next boot.
	CONNECTED	Connect	Connected to download PID — awaiting data.
	PEND CONNECT	TryingToConnect	Trying to connect.
<b>ID</b>	The object identifier.		
<b>LO</b>	The Local Origination states whether the object is located locally on the set-top.		





## Memory Configuration

This diagnostic displays the DCX3510-M memory configuration. The information is updated when you display the diagnostic.

MEMORY CONFIGURATION	
SYSTEM RAM:	768 MB
FLASH:	64 MB
NVRAM:	N/A

**Figure 38: Memory Configuration Diagnostic Screen**

*Note: There is no front panel display for this diagnostic.*

**Table 19: Memory Configuration Diagnostic Field Descriptions**

Field	Description
<b>System RAM</b>	The allocated system RAM in MB.
<b>Flash</b>	The allocated flash memory in MB.
<b>NVRAM</b>	The allocated NVRAM in KB.

## Audio/Video Status

Audio/Video Status diagnostics display information regarding audio and video content and settings configured for the set-top.



```

                AUDIO / VIDEO STATUS
SPDIF:DOLBY DIGITAL 3/2      LFE:   1
Dolby Volume: OFF
Audio Mute:   ON
Video Mute:   MUTED
Captions Detected:      N/A
N/A              Primary Lang
Digital subtitles status
  Enabled:     NO        ISO Lang:   eng
  Enhanced:   NO        Rendered:   NO
PiP Focus:    N/A
OUTPUT FORMAT:      N/A
INPUT SOURCE:      IB TUNER 1
ADP LOCK:         YES
AUDIO MODE:       STEREO
VP LOCK:         YES
INPUT FORMAT:     4:3 704x480i 30

```

**Figure 39: Audio/Video Status Diagnostic Screen**

**Table 20: Audio/Video Status Diagnostic Field Descriptions**

Field	Description																						
<b>S/PDIF Output</b>	Indicates S/PDIF Mode as set by application software.																						
	<table border="1"> <thead> <tr> <th>OSD Display</th> <th>Description</th> </tr> </thead> <tbody> <tr> <td>N/A</td> <td>Audio S/PDIF mode is not applicable.</td> </tr> <tr> <td>IEC958PCM</td> <td>PCM audio selected.</td> </tr> <tr> <td>Dolby Digital</td> <td>Dolby Digital uses the following speaker selections:</td> </tr> <tr> <td>1/0</td> <td>Right front or left front</td> </tr> <tr> <td>2/0</td> <td>Right front and left front</td> </tr> <tr> <td>3/0</td> <td>Right front and left front and center</td> </tr> <tr> <td>2/1</td> <td>Right front and left front and (right rear or left rear)</td> </tr> <tr> <td>3/1</td> <td>Right front and left front and center and (right rear or left rear)</td> </tr> <tr> <td>2/2</td> <td>Right front and left front and right rear and left rear</td> </tr> <tr> <td>3/2</td> <td>Right front and left front and center and right rear and left rear</td> </tr> </tbody> </table>	OSD Display	Description	N/A	Audio S/PDIF mode is not applicable.	IEC958PCM	PCM audio selected.	Dolby Digital	Dolby Digital uses the following speaker selections:	1/0	Right front or left front	2/0	Right front and left front	3/0	Right front and left front and center	2/1	Right front and left front and (right rear or left rear)	3/1	Right front and left front and center and (right rear or left rear)	2/2	Right front and left front and right rear and left rear	3/2	Right front and left front and center and right rear and left rear
OSD Display	Description																						
N/A	Audio S/PDIF mode is not applicable.																						
IEC958PCM	PCM audio selected.																						
Dolby Digital	Dolby Digital uses the following speaker selections:																						
1/0	Right front or left front																						
2/0	Right front and left front																						
3/0	Right front and left front and center																						
2/1	Right front and left front and (right rear or left rear)																						
3/1	Right front and left front and center and (right rear or left rear)																						
2/2	Right front and left front and right rear and left rear																						
3/2	Right front and left front and center and right rear and left rear																						
<b>LFE: Low Frequency Effect</b>	The LFE indicates if the nomenclature low frequency effects are available in the Dolby Digital audio stream, as indicated if the "0.1" is present in the Dolby Digital 5.1 nomenclature (for example, "Dolby Digital 5.1 surround"). Valid values include:																						
	<table border="1"> <thead> <tr> <th>OSD Display</th> <th>Description</th> </tr> </thead> <tbody> <tr> <td>0</td> <td>LFE is not available</td> </tr> <tr> <td>1</td> <td>LFE is available (i.e. "Dolby Digital 5.1 surround").</td> </tr> </tbody> </table>	OSD Display	Description	0	LFE is not available	1	LFE is available (i.e. "Dolby Digital 5.1 surround").																
OSD Display	Description																						
0	LFE is not available																						
1	LFE is available (i.e. "Dolby Digital 5.1 surround").																						



Field	Description												
<b>Dolby Volume</b>	Indicates if Dolby Volume is turned on or off												
<b>Audio / Video Mute</b>	The Audio and Video Mute Status indicates if the audio and/or video have been muted by the software. The audio mute is either On or Off. The Video Mute describes the MPEG muting method selected by the software and indicates if the output video is in the mute state by displaying On or Off, followed by the mute method. Methods include:												
	<table border="1"> <thead> <tr> <th>OSD Display</th> <th>Description</th> </tr> </thead> <tbody> <tr> <td>UNMUTED</td> <td>Displayed if the mute method is not selected.</td> </tr> <tr> <td>MUTE to STILL</td> <td>Displayed if the mute method includes stopping video and presenting a still frame, similar to a pause function.</td> </tr> <tr> <td>MUTE to BLACK</td> <td>Displayed if mute method presents a black screen.</td> </tr> </tbody> </table>	OSD Display	Description	UNMUTED	Displayed if the mute method is not selected.	MUTE to STILL	Displayed if the mute method includes stopping video and presenting a still frame, similar to a pause function.	MUTE to BLACK	Displayed if mute method presents a black screen.				
OSD Display	Description												
UNMUTED	Displayed if the mute method is not selected.												
MUTE to STILL	Displayed if the mute method includes stopping video and presenting a still frame, similar to a pause function.												
MUTE to BLACK	Displayed if mute method presents a black screen.												
<b>Captions</b>	The captions mode displays captions present on the service. Note: The caption options are set via the User Setting Menu, where the subscriber can enable closed captions and select options.												
<b>1<sup>st</sup> Caption Row: Caption Detected:</b>													
	<table border="1"> <thead> <tr> <th>OSD Display</th> <th>Description</th> </tr> </thead> <tbody> <tr> <td>708</td> <td>EIA-708 captions detected.</td> </tr> <tr> <td>608</td> <td>EIA-608 captions detected.</td> </tr> <tr> <td>608 and 708</td> <td>Both EIA-608 and EIA-708 captions detected.</td> </tr> <tr> <td>None</td> <td>No captions detected.</td> </tr> </tbody> </table>	OSD Display	Description	708	EIA-708 captions detected.	608	EIA-608 captions detected.	608 and 708	Both EIA-608 and EIA-708 captions detected.	None	No captions detected.		
OSD Display	Description												
708	EIA-708 captions detected.												
608	EIA-608 captions detected.												
608 and 708	Both EIA-608 and EIA-708 captions detected.												
None	No captions detected.												
<b>2<sup>nd</sup> Caption Row: Caption Options Set, followed by Service Selected:</b>													
	<table border="1"> <thead> <tr> <th>OSD Display</th> <th>Description</th> </tr> </thead> <tbody> <tr> <td>708 Set</td> <td>EIA-708 captions enabled, with options set by user.</td> </tr> <tr> <td>708 Default</td> <td>EIA-708 captions enabled, with no options set by user.</td> </tr> <tr> <td>608 Set</td> <td>EIA-608 captions enabled, with options set by user.</td> </tr> <tr> <td>608 Default</td> <td>EIA-608 captions enabled, with no options set by user.</td> </tr> <tr> <td>None Set</td> <td>Captions detected but not enabled.</td> </tr> </tbody> </table>	OSD Display	Description	708 Set	EIA-708 captions enabled, with options set by user.	708 Default	EIA-708 captions enabled, with no options set by user.	608 Set	EIA-608 captions enabled, with options set by user.	608 Default	EIA-608 captions enabled, with no options set by user.	None Set	Captions detected but not enabled.
OSD Display	Description												
708 Set	EIA-708 captions enabled, with options set by user.												
708 Default	EIA-708 captions enabled, with no options set by user.												
608 Set	EIA-608 captions enabled, with options set by user.												
608 Default	EIA-608 captions enabled, with no options set by user.												
None Set	Captions detected but not enabled.												
	<table border="1"> <thead> <tr> <th>OSD Display</th> <th>Definition</th> </tr> </thead> <tbody> <tr> <td>CC 1</td> <td>Closed Caption service CC 1 (default)</td> </tr> <tr> <td>CC 2</td> <td>Closed Caption service CC 2</td> </tr> <tr> <td>CC 3</td> <td>Closed Caption service CC 3</td> </tr> <tr> <td>CC 4</td> <td>Closed Caption service CC 4</td> </tr> </tbody> </table>	OSD Display	Definition	CC 1	Closed Caption service CC 1 (default)	CC 2	Closed Caption service CC 2	CC 3	Closed Caption service CC 3	CC 4	Closed Caption service CC 4		
OSD Display	Definition												
CC 1	Closed Caption service CC 1 (default)												
CC 2	Closed Caption service CC 2												
CC 3	Closed Caption service CC 3												
CC 4	Closed Caption service CC 4												

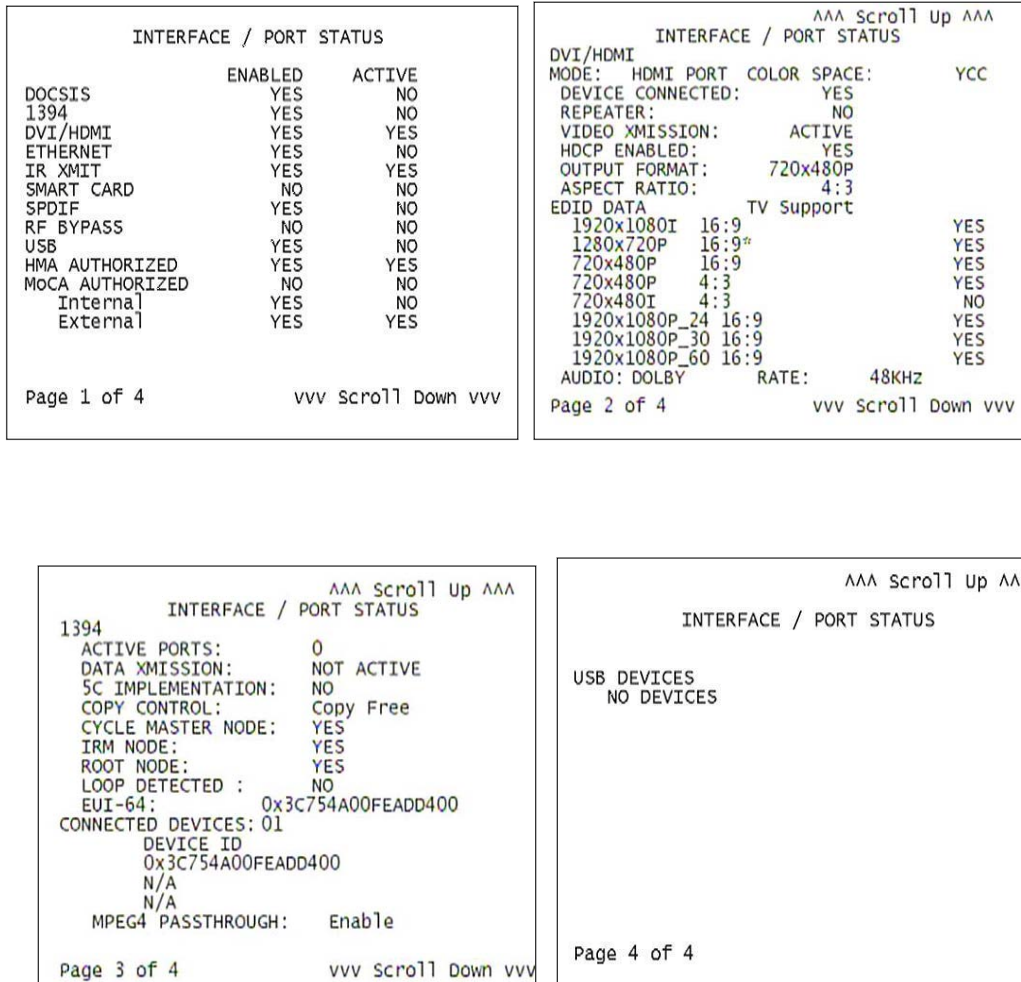


Field	Description
T 1	Closed Caption service T 1
T 2	Closed Caption service T 2
T 3	Closed Caption service T 3
T 4	Closed Caption service T 4
OSD Display	Description
Primary Lang	Primary language set by the provider (default, Service 1).
Second Lang	Secondary language set by the provider (Service 2).
Service 3	Set by the provider Service 3.
Service 4	Set by the provider Service 4.
Service 5	Set by the provider Service 5.
Service 6	Set by the provider Service 6.
<b>Digital Subtitle Status</b>	<p>The subtitle parameter indicates if subtitles are enabled and, if enabled, what language is selected and if the subtitle is being rendered. The language is displayed as the 3-character ISO639.2/B language code.</p> <ul style="list-style-type: none"> <li>• Enabled is indicated with Yes or No.</li> <li>• The language is displayed as the 3-character ISO639.2 language code.</li> <li>• Enhanced mode is indicated with Yes or No.</li> <li>• Rendered status is indicated with Yes or No.</li> </ul>
<b>Output Format</b>	Standard used for the output format if available, ie. NTSC video standard
<b>Input Sources</b>	<p>The input source list information on ADP Lock, Audio Mode, VP lock, and Input Format.</p> <p>The ADP Lock indicates whether the audio stream is locked. Valid values are:</p> <ul style="list-style-type: none"> <li>• YES: Audio Processor is locked to the audio stream.</li> <li>• NO: Audio Processor is not locked to the audio stream.</li> </ul> <p>Audio Mode indicates the audio Mode of in incoming digital service. Valid values include:</p> <ul style="list-style-type: none"> <li>• N/A: The audio mode is not applicable to the currently tuned stream.</li> <li>• Mono: The audio mode is monophonic.</li> <li>• Stereo: The audio mode is stereo.</li> <li>• Surround: The audio mode is surround sound.</li> <li>• 5.1: The audio mode is Dolby® Digital 5.1 Surround Sound.</li> </ul> <p>VP Lock indicates whether the video stream is locked. Valid values are:</p> <ul style="list-style-type: none"> <li>• YES: Video Processor is locked to the video stream.</li> <li>• NO: Video Processor is not locked to the video stream.</li> </ul> <p>The input format includes the aspect ratio (4:3 or 16:9), the screen pixel size (nnnnXnnnn), pixel display ('i' for interlaced, 'p' for progressive), and frames per second (24, 25, 30, or 60).</p>



## Interface Status

The Interface Status diagnostic displays when running in Thin Client. There is no LED display. The information on the OSD is updated when you display the diagnostic.



**Figure 40: Interface Status Diagnostic Screens**

**Table 21: Interface Status Diagnostic Field Descriptions**

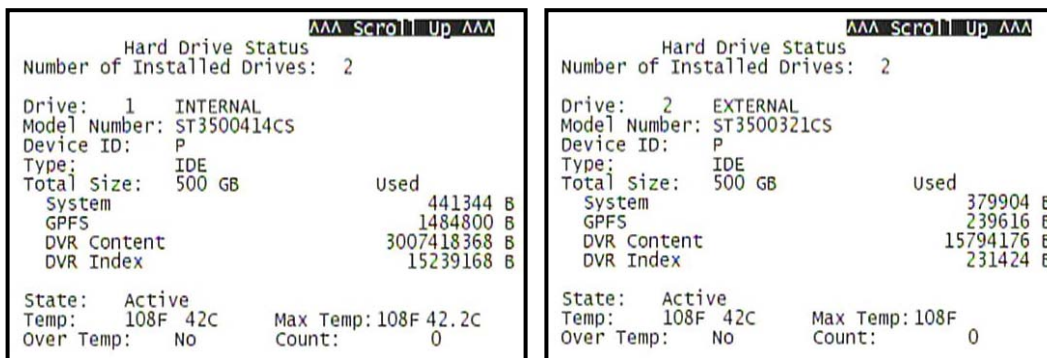
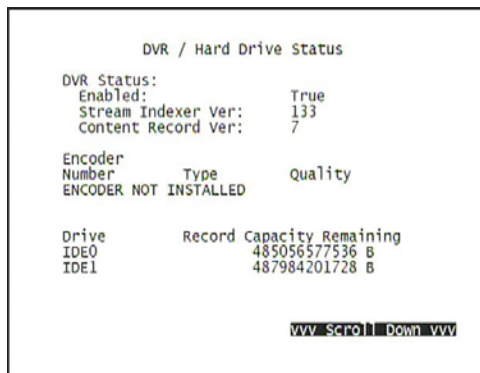
Field	Description
<b>DOCSIS Tuner &amp; Xmitter</b>	Indicates if enabled; indicates if active.
<b>1394 I/O Device</b>	Indicates if enabled; indicates if active.
<b>USB I/O Device</b>	Indicates if enabled; indicates if active.
<b>Ethernet Device</b>	Indicates if enabled; indicates if active.
<b>Parallel Port</b>	Indicates if enabled; indicates if active.
<b>IR Xmit</b>	Indicates if enabled; indicates if active.
<b>Hard Drive Status</b>	Indicates if enabled; indicates if active.
<b>Smart Card</b>	Indicates if enabled; indicates if active.
<b>HDMI Port</b>	<p>If a device is connected to the HDMI port only, the following diagnostics display to help troubleshoot the HDMI interface. They all display “N/A” if no device is connected to the HDMI port, or if the value is invalid or cannot be retrieved.</p> <ul style="list-style-type: none"> <li>• Device Connected — Indicates whether a device is connected to the HDMI port— Yes or No.</li> <li>• Repeater — Indicates whether the connected device is a repeater — Yes or No.</li> <li>• Video Xmission (transmission) — Indicates whether the DCX3510-M is transmitting video over the HDMI port — Not Active or Active.</li> <li>• HDCP Enabled — Indicates whether the DCX3510-M is using HDCP to encrypt video transmitted over the HDMI link — Yes or No. If the Video Xmission status is Not Active, the HDCP Enabled status is No.</li> <li>• Output Format — Indicates the timing format of the video sent through HDMI: <ul style="list-style-type: none"> <li>• 1920 x 1080i — 1920 pixels wide by 1080 pixels high, interlaced</li> <li>• 1280 x 720p — 1280 pixels wide by 720 pixels high, progressive</li> <li>• 720 x 480p — 720 pixels wide by 480 pixels high, progressive</li> <li>• 720 x 480i — 720 pixels wide by 480 pixels high, interlaced</li> <li>• 640 x 480p — 640 pixels wide by 480 pixels high, progressive</li> </ul> </li> <li>• Aspect Ratio — Indicates the aspect ratio of the video sent through HDMI — 4:3 or 16:9.</li> </ul>
<b>EDID Data</b>	<p>Indicates the video timing formats that were read from the Extended Display Identification Data (EDID) register for the connected device, in particular the detailed timing description blocks. The list displays all of the formats that the DCX3510-M could read, up to a maximum of 12 formats. If the DCX3510-M cannot read any formats, EDID Data is blank. An asterisk (*) after the aspect ratio means the DCX3510-M supports the format. If more than twelve video timing formats are discovered, the supported formats only are listed first, followed by up to twelve remaining formats.</p>
<b>1394 Information</b>	<p>If a connection is made to a 1394 device, the screen indicates:</p> <ul style="list-style-type: none"> <li>• Active Ports – number of active ports detected</li> <li>• Data XMission – if data flow is detected through the port</li> <li>• 5C implementation – indicates the level 5C DTCP authentication currently</li> </ul>



Field	Description
	<p>employed on the 1394 interface</p> <ul style="list-style-type: none"> <li>• Copy Control - level of copy control in the 1394 content. Valid values include: 'Copy Free', 'Copy Once', 'No Copies', 'Copy Never'.</li> <li>• Nodes - indicates if the set-top terminal is the cycle master node, the IRM node, and/or the root node on the 1394 bus.</li> <li>• Loop Detected - indicates if a loop exists on the 1394 bus.</li> <li>• EUI – device identifier</li> <li>• Number of connected devices and associated device Identifier</li> <li>• MPEG4 Passthrough – indicated if MPEG4 content is passed through to the 1394 device. The user can enable or disable MPEG4 Passthrough by pressing the MENU key while on the 1394 Status OSD diagnostics screen (selection mode is indicated by '&gt;&gt;&gt;'), then pressing SELECT key to toggle between Enable and Disable.</li> </ul>

## DVR/Hard Drive Status

This three-page diagnostic displays the DVR and hard-drive status.



**Figure 41: DVR/Hard Drive Status Diagnostic Screens**

**Table 22: DVR/Hard Drive Status Diagnostic Field Descriptions**

Field	Description						
<b>Enabled</b>	Indicates whether the DVR is enabled, based on the DCX3510-M Connected State (CONNECTED or DISCONNECTED) and resource availability (resource authorized; hard disk installed and functional):						
	<table border="1"> <thead> <tr> <th>OSD</th> <th>Front panel</th> <th>Description</th> </tr> </thead> <tbody> <tr> <td>True</td> <td>En</td> <td>DVR enabled</td> </tr> </tbody> </table>	OSD	Front panel	Description	True	En	DVR enabled
OSD	Front panel	Description					
True	En	DVR enabled					
	<table border="1"> <thead> <tr> <th>Front Panel</th> <th>OSD</th> <th>Description</th> </tr> </thead> <tbody> <tr> <td>False</td> <td>Un</td> <td>DVR disabled</td> </tr> </tbody> </table>	Front Panel	OSD	Description	False	Un	DVR disabled
Front Panel	OSD	Description					
False	Un	DVR disabled					
<b>Stream Indexer Ver.</b>	The stream indexer version number, without leading zeros; for example, version 0000000065 is displayed as 65.						
<b>Content Record Ver.</b>	The content record version number, displayed without leading zeros.						
<b>Encoder</b>	Encoder Not Installed						
<b>Number</b>	Encoder Not Installed						
<b>Type</b>	Encoder Not Installed						
<b>Quality</b>	Encoder Not Installed						
<b>Drive</b>	The drive type — IDE or NOT AVAILABLE (neither enabled nor configured).						
<b>Record Capacity Remaining</b>	The remaining recording capacity, in bytes.						
<b>Number of Installed Drives</b>	The number of internal and external hard drives, up to a maximum of 9.						
<b>Drive</b>	The identification number sequentially assigned to each installed drive and whether the drive is Internal or External.						
<b>Model Number</b>	The drive model number assigned at the factory.						
<b>Device ID</b>	A text string of up to 20 characters that identifies the disk drive; N/A is displayed if the value is invalid or cannot be retrieved.						
<b>Type</b>	The drive type — IDE, 1394, USB, or Unknown.						
<b>Total Size</b>	The drive size in decimal GB. (1 decimal GB = 1 x 109 bytes. For example, 120 decimal GB = 120 x 109 bytes.)						
<b>System, GPFS, DVR Content, and DVR Index</b>	The space used and allocated in MB for each of the internal hard drive's partitions — System, GPFS, DVR Content, and DVR Index (1 binary MB = 220 bytes). N/A displays if the value is invalid or cannot be retrieved.						



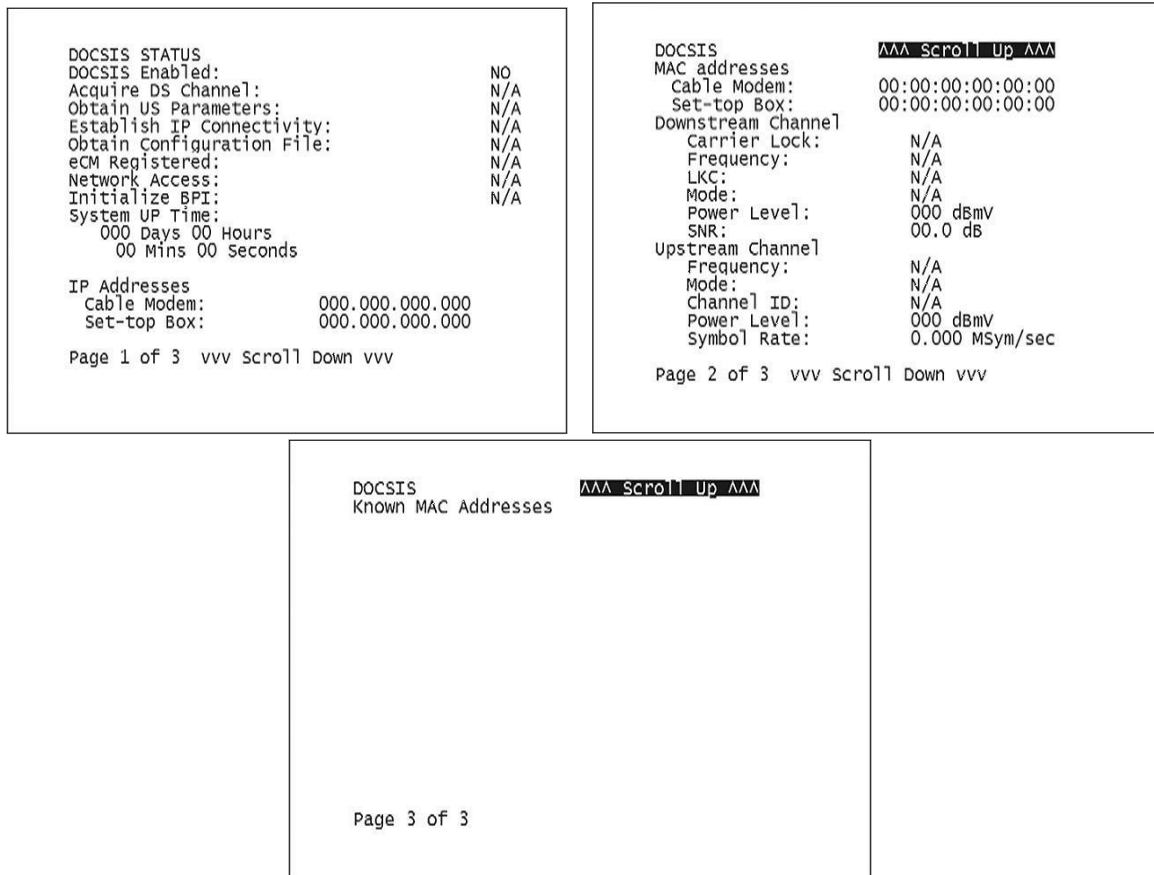


Field	Description
<b>State</b>	The hard drive state: <ul style="list-style-type: none"><li>• Standby — The hard drive is working normally, but is at rest (the State returns to Active any time disc access is necessary).</li><li>• Active — The hard drive is accessing data.</li><li>• Failed — The hard drive hardware has failed.</li></ul>
<b>Temp (F)</b>	For an internal hard drive only, its temperature in degrees F.
<b>Max Temp</b>	For an internal hard drive only, its maximum temperature in degrees F.
<b>Over Temp</b>	Indicates whether the drive is excessively hot: <ul style="list-style-type: none"><li>• Yes — The internal drive temperature exceeds 140° F (60° C). The LED Over-Temp Indicator is on and remains lit until the next over-temp sample is taken (at least once an hour).</li><li>• No — There is no over temp problem.</li></ul>
<b>Count</b>	The cumulative number of times that the hard drive temperature has been measured over 60° C, with the temperature checked at least once an hour.



## DOCSIS Status

This three-screen diagnostic displays status information for the embedded cable modem (eCM):



**Figure 42: DOCSIS Status Diagnostic Screens**

**Table 23: DOCSIS Status Diagnostic Field Descriptions**

Field	Description
<b>DOCSIS Enabled</b>	For a DOCSIS-enabled set-top, YES. Otherwise, NO.
<b>Acquire DS Channel</b>	The DOCSIS downstream channel acquisition status: <ul style="list-style-type: none"> <li>• YES — The downstream channel is acquired.</li> <li>• NO — The set-top is acquiring the downstream channel.</li> <li>• N/A — The value is invalid, cannot be retrieved, or DOCSIS is not enabled.</li> </ul>
<b>Obtain US Parameters</b>	The DOCSIS upstream channel descriptor (UCD) acquisition status: <ul style="list-style-type: none"> <li>• YES — The UCD is acquired.</li> <li>• NO — The set-top is acquiring the UCD or the downstream channel.</li> </ul>



Field	Description
	<ul style="list-style-type: none"> <li>• N/A — The value is invalid or cannot be retrieved, or DOCSIS is not enabled.</li> </ul>
<b>Establish IP Connectivity</b>	<p>Displays whether the cable modem has acquired its IP address, typically from a Dynamic Host Configuration Protocol (DHCP) server:</p> <ul style="list-style-type: none"> <li>• YES — The IP address is acquired.</li> <li>• NO — The set-top is acquiring its IP address.</li> <li>• N/A — The value is invalid or cannot be retrieved, or DOCSIS is not enabled.</li> </ul>
<b>Obtain Configuration File</b>	<p>Displays whether the cable modem has downloaded its DOCSIS cable modem configuration file from the TFTP server:</p> <ul style="list-style-type: none"> <li>• YES — The cable modem configuration file has been successfully downloaded.</li> <li>• NO — The set-top is downloading its cable modem configuration file.</li> <li>• N/A — The value is invalid or cannot be retrieved, or DOCSIS is not enabled.</li> </ul>
<b>eCM Registered</b>	<p>Displays whether the embedded cable modem has registered with the cable modem termination system (CMTS):</p> <ul style="list-style-type: none"> <li>• YES — DOCSIS registration is complete.</li> <li>• NO — DOCSIS registration is in progress, or the set-top could not register.</li> <li>• N/A — The value is invalid or cannot be retrieved, or DOCSIS is not enabled.</li> </ul>
<b>Network Access</b>	<p>Displays whether the cable modem has been granted access to the DOCSIS network:</p> <ul style="list-style-type: none"> <li>• YES — The cable modem was granted DOCSIS network access.</li> <li>• NO — The set-top is obtaining DOCSIS network access.</li> <li>• N/A — The value is invalid or cannot be retrieved, or DOCSIS is not enabled.</li> </ul>
<b>Initialize BPI</b>	<p>The Baseline Privacy Interface (BPI) status:</p> <ul style="list-style-type: none"> <li>• YES — BPI has been successfully initialized for the cable modem.</li> <li>• NO — BPI initialization is in progress, has failed, or was not requested by the network.</li> <li>• N/A — The value is invalid or cannot be retrieved, or DOCSIS is not enabled.</li> </ul>
<b>System Up Time</b>	<p>The Days, Hours, Mins (minutes), and Seconds the DOCSIS system has been operational. If the value is invalid or cannot be retrieved, or if DOCSIS is not enabled, each field displays zeros.</p>
<b>IP Addresses</b>	<p>The Cable Modem and Set-Top IP addresses in dotted-decimal format xxx.xxx.xxx.xxx. Each byte value is padded with zeros when necessary. For example, 10.0.1.10 is displayed as 010.000.001.010. If the value is invalid or cannot be retrieved, or if DOCSIS is not enabled, 000.000.000.000 is displayed.</p>
<b>MAC Addresses</b>	<p>The Cable Modem and Set-Top MAC address in hexadecimal format xx:xx:xx:xx:xx:xx. Each byte value xx ranges from 00 to FF and is padded with zeros when necessary. For example, 0:0:2D:1:F1:D is displayed as 00:00:2D:01:F1:0D. If the value is invalid or cannot be retrieved, or if DOCSIS is not enabled, 00:00:00:00:00:00 is displayed.</p>
<b>Downstream Channel (carries data from the headend to the set-top)</b>	
<b>Carrier Lock</b>	<ul style="list-style-type: none"> <li>• YES — The cable modem is locked to a DOCSIS downstream channel.</li> </ul>



Field	Description
	<ul style="list-style-type: none"> <li>• NO — The cable modem is not locked to a downstream channel.</li> <li>• N/A — The value is invalid or cannot be retrieved, or DOCSIS is not enabled.</li> </ul>
<b>Frequency</b>	The center frequency of the channel to which the DOCSIS downstream channel receiver is tuned. It can be 54 to 860 MHz. If the value is invalid or cannot be retrieved, downstream Carrier Lock is No; if DOCSIS is not enabled, N/A is displayed.
<b>LKC</b>	The last known carrier (LKC); the frequency of the last tuned downstream channel used if the embedded cable modem enters hunt mode. It can be 54 to 860 MHz. If the value is invalid or cannot be retrieved, Carrier Lock is No; if DOCSIS is not enabled, N/A is displayed.
<b>Mode</b>	The DOCSIS downstream channel modulation: QAM 64 or QAM 256. If the value is invalid or cannot be retrieved, Carrier Lock is No; if DOCSIS is not enabled, 000 is displayed.
<b>Power Level</b>	The downstream channel power level in dBmV. If the value is invalid or cannot be retrieved, Carrier Lock is No; if DOCSIS is not enabled, 000 is displayed.
<b>SNR</b>	The estimated downstream channel carrier signal-to-noise ratio in the format xx.x dB. It is the value reported as SNR in the MIB. If the value is invalid or cannot be retrieved, Carrier Lock is No; if DOCSIS is not enabled, 00.0 is displayed.
<b>Upstream Channel (carries data from the set-top to the headend)</b>	
<b>Frequency</b>	The center frequency of the channel to which the DOCSIS upstream channel receiver is tuned. It can be 5 to 42 MHz. If the value is invalid or cannot be retrieved, Carrier Lock is No; if DOCSIS is not enabled, N/A is displayed.
<b>Mode</b>	The DOCSIS upstream channel modulation: QPSK, QAM 8, QAM 16, QAM 32, QAM 64, or QAM 128. If the value is invalid or cannot be retrieved, or if DOCSIS is not enabled, N/A is displayed.
<b>Channel ID</b>	The upstream channel identifier 0 to 255. If the value is invalid or cannot be retrieved, or if DOCSIS is not enabled, N/A is displayed.
<b>Power Level</b>	The upstream channel power level in dBmV. If the value is invalid or cannot be retrieved, or if DOCSIS is not enabled, 000 is displayed.
<b>Symbol Rate</b>	The upstream channel symbol rate in mega-symbols per second. If the value is invalid or cannot be retrieved, or if DOCSIS is not enabled, 0.000 is displayed.
<b>Known MAC Addresses</b>	Displays up to 32 MAC addresses learned by the DCX3510-M cable modem, including the Set-Top MAC and future MAC addresses assigned by DSG, in hexadecimal format xx:xx:xx:xx:xx:xx on two screens if necessary. If the value is invalid or cannot be retrieved, or if DOCSIS is not enabled, no values are displayed.



## Application Specific Information

This diagnostic displays information about application servers:

```

APPLICATION SPECIFIC INFORMATION
NO ADDITIONAL INFORMATION
SERVER 1 NAME:
SRV 1 IP ADDR:

SERVER 2 NAME:
SRV 2 IP ADDR:

SERVER 3 NAME:
SRV 3 IP ADDR:

SERVER 4 NAME:
SRV 4 IP ADDR:

SERVER 5 NAME:
SRV 5 IP ADDR:

```

**Figure 43: Application Specific Information Diagnostic Screen**

**Table 24: Application Specific Information Diagnostic Field Descriptions**

Field	Description
<b>Server# Name</b>	The application server name of up to 14 alphanumeric characters. It is blank if the value is invalid or no value can be retrieved.
<b>Srvr # IP Addr</b>	The application server's IP address in dotted-decimal format xxx.xxx.xxx.xxx; the range of each xxx is from 0 to 255. It is blank if the value is invalid or no value can be retrieved.

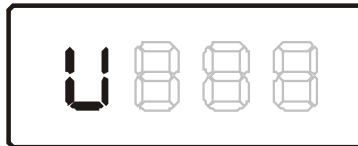


## Interactive Status

This diagnostic describes the interactive information that is displayed only when the Thin Client platform is running. The information on the OSD and front panel is updated at least once every five seconds while the diagnostic is displayed. This is an example of a code module display with status descriptions:

INTERACTIVE STATUS			
IP ADDRESS:			000.000.000.000
UPM:			00000017
UPSTREAM ID:			0000
DOWNSTREAM ID:			0000
STATE:			UNCONFIG
MAC ABORT CNTR:			0000
SOCKET PORT STATE:			
00	UNUSED	08	UNUSED
01	UNUSED	09	UNUSED
02	UNUSED	10	UNUSED
03	UNUSED	11	UNUSED
04	UNUSED	12	UNUSED
05	UNUSED	13	UNUSED
06	UNUSED	14	UNUSED
07	UNUSED		

**Figure 44: Interactive Status Diagnostic Screen**



**Figure 45: Interactive Status Front Panel Display**

**Table 25: Interactive Status Diagnostic Field Descriptions**

Field	Description		
<b>IP Address</b>	The IP address in dotted-decimal format xxx.xxx.xxx.xxx assigned by the NC 1500 to the DCX3510-M. 0.0.0.0 is displayed if the IP address is not configured or unknown.		
<b>UPM</b>	The upstream modem address value is the same as the terminal ID assigned by the DAC 6000. It is a unique, system-generated, eight-digit integer between 1 and 16777215. 00000000 is displayed when the UPM is not configured or if it is unknown.		
<b>Upstream ID</b>	A four-digit decimal value from 0000 to 9999 assigned by the DAC 6000 to the DCX3510-M. 0000 is displayed if the Upstream ID is not configured or if it is unknown.		
<b>Downstream ID</b>	A four-digit decimal value from 0000 to 9999 assigned by the DAC 6000 to the DCX3510-M. 0000 is displayed if the Downstream ID is not configured or if it is unknown.		
<b>State</b>	The interactive status of the DCX3510-M:		
	<b>Front Panel</b>	<b>OSD</b>	<b>Description</b>
	U	UNCONFIG	The DCX3510-M is not configured for the interactive system, and the platform should run as pre-interactive.
	C	MAC_CONNECT	The DCX3510-M is waiting to establish a connection to the MAC PID Stream.
	<b>Front Panel</b>	<b>OSD</b>	<b>Description</b>
	I dc	INIT_WAIT_DC_OR_C	The DCX3510-M is in the interactive initialization state and waiting for the default configuration or the contention channel list messages.
	I L	WAIT_LM_ACK	The DCX3510-M is in the interactive initialization state and waiting for Link Management Response ACK for Local Address Message.
	I SO	WAIT_SO_ACK	The DCX3510-M is in the interactive initialization state and waiting for a Sign On acknowledgement.
	I LA	WAIT_LA_OR_SO	The DCX3510-M is in the interactive initialization state and waiting for Logical Address or Sign On with verification Frequency message.



Field	Description
S I	INIT_STOPPED The DCX3510-M is in the interactive initialization state and the TransMode has stopped.
r dc	RUN_WAIT_DC_OR_C The DCX3510-M is in the interactive state and waiting for the default configuration or the contention channel list messages.
r	RUNNING Interactive state is running, sending idle messages, and waiting for any prepare for poll or MAC messages.
S	RUN_STOPPED The interactive run state has stopped and DCX3510-M is waiting for status or a transmission control message.
00	INVALID The interactive state is unknown or invalid.
<b>MAC Abort Cntr</b>	This counter increments every time the MAC layer reaches the cell abort count limit. It is reset by the successful upstream transmission of a cell: for example, when the DCX3510-M receives an ACK. If the counter reaches the MAC abort count limit, the DCX3510-M assumes the MAC layer is unavailable due to noise, congestion, or some other problem. The DCX3510-M stops transmitting data upstream, reports an error to the calling function, and attempts to re-enter the network using the initialization process. 0000 is displayed as the default or the MAC Abort CNTR is unconfigured or unknown.
<b>Socket Port State</b>	The socket mode and activity: <ul style="list-style-type: none"> <li>• UNUSED — The socket is not being used.</li> <li>• OPENED — The socket is open.</li> <li>• READY — The socket is ready to send or receive.</li> <li>• RECEIVING — The socket is receiving data from the application server.</li> <li>• SENDING — The socket is sending data to the application server.</li> <li>• UNKNOWN — The socket state is invalid or unknown.</li> </ul>





## Connected Home

This diagnostic displays the connectivity and status of the Connect Home Network.

AAA Scroll Up AAA

Connected Home Status  
 RF Freq: N/A MoCA: N/A  
 RF Password:  
 Nodes Dev(#Ses)/Ver MAC/IP

Page 1 of 5 VVV Scroll Down VVV

AAA Scroll Up AAA

Connected Home Status  
 RF Freq: N/A MoCA: N/A  
 RF Password:  
 Nodes Dev(#Ses)/Ver MAC/IP

Page 2 of 5 VVV Scroll Down VVV

AAA Scroll Up AAA

Connected Home Status  
 RF Freq: N/A MoCA: N/A  
 RF Password:  
 Nodes Dev(#Ses)/Ver MAC/IP

Page 3 of 5 VVV Scroll Down VVV

AAA Scroll Up AAA

Connected Home Link Status  
 TX Data Rate Between Nodes (Mbps)  
 Collecting Data: N/A  
 To Node: 0 1 2 3 4  
 From Node:  
 0 \*\*\* N/A N/A N/A N/A  
 1 N/A \*\*\* N/A N/A N/A  
 2 N/A N/A \*\*\* N/A N/A  
 3 N/A N/A N/A \*\*\* N/A  
 4 N/A N/A N/A N/A \*\*\*  
 5 N/A N/A N/A N/A N/A  
 6 N/A N/A N/A N/A N/A  
 7 N/A N/A N/A N/A N/A

Page 4 of 5 VVV Scroll Down VVV

AAA Scroll Up AAA

Connected Home Link Status  
 TX Data Rate Between Nodes (Mbps)  
 Collecting Data: N/A  
 To Node: 5 6 7  
 From Node:  
 0 N/A N/A N/A  
 1 N/A N/A N/A  
 2 N/A N/A N/A  
 3 N/A N/A N/A  
 4 N/A N/A N/A  
 5 \*\*\* N/A N/A  
 6 N/A \*\*\* N/A  
 7 N/A N/A \*\*\*

Page 5 of 5 VVV Scroll Down VVV

**Figure 46: Connected Home Diagnostic Screens**

**Table 26: Connected Home Diagnostic Field Descriptions**

Field	Description
<b>RF Freq</b>	Frequency on which the Connected Home network is communicating.
<b>MoCA</b>	MoCA network status.
<b>RF Password</b>	RF Password is used when the MoCA network has privacy enabled.
<b>Nodes</b>	Node number for each member of network.
<b>Dev(#Ses)/Ver</b>	Number of active content sessions running on each member of network.
<b>MAC/IP</b>	Hardware and Network addresses for each member of the network.
<b>Collecting Data</b>	Displays whether data collecting is taking place on the network.
<b>To Node</b>	Nodes currently sending data over the network.
<b>From Node</b>	Nodes currently receiving data over the network.



# 6

## Troubleshooting

The following information can help troubleshoot some more common issues. If problems still occur after performing the diagnostics, call the TRC for assistance as described in the Introduction section of this manual.

Problem	Possible Solution
<p><b>The DCX3510-M will not power on</b></p>	<ul style="list-style-type: none"> <li>• Verify that the AC power cord is connected to the DCX3510-M and an AC outlet. Unplug the DCX3510-M from the AC outlet, plug it back in, and then press the POWER button.</li> <li>• If the DCX3510-M is connected to a switched outlet on another unit, verify that that unit is powered on. Unplug the power cord from the DCX3510-M's AC outlet, plug it back in, and then press the POWER button. It is recommended to use an unswitched outlet, if possible.</li> <li>• Press the POWER button on the DCX3510-M's front panel instead of the remote control. The batteries in the remote control may be depleted.</li> </ul>
<p><b>The remote control does not work</b></p>	<ul style="list-style-type: none"> <li>• Verify that the remote control is in Cable mode.</li> <li>• Verify that the remote is programmed for Motorola remote codes.</li> <li>• Verify that there are no obstructions between the remote control and the DCX3510-M. Aim the remote control directly at the DCX3510-M front panel, not the TV or VCR.</li> <li>• The angle between the remote control and the DCX3510-M may be too large. Stand in front of the DCX3510-M and not too far to either side.</li> <li>• Press and release operation keys one at a time, firmly and deliberately.</li> <li>• Check the batteries in the remote control. Install new batteries if needed.</li> </ul>
<p><b>There is no audio when viewing cable channels</b></p>	<ul style="list-style-type: none"> <li>• Verify that the mute button on the remote control has not been pressed. Press mute on the remote control to restore sound.</li> <li>• If the DCX3510-M audio output is connected to the TV, verify that the mute button on the TV has not been pressed.</li> <li>• If the DCX3510-M audio output is connected to a home theater receiver, verify that the receiver is set to the appropriate input source and the mute button on the receiver has not been pressed.</li> <li>• Verify that you have the correct cables for the audio connections.</li> <li>• Verify that the audio cables are firmly connected between the DCX3510-M and the audio playback device (TV, receiver, DVD player, etc.).</li> </ul>
<p><b>There is no audio from the center and/or surround speakers of a home theater receiver connected to the DCX3510-M</b></p>	<p>Not all programs feature full Dolby Digital [5.1] or Dolby Digital Plus [7.1] surround sound. In some cases, the programs may only contain left and right stereo audio.</p> <ul style="list-style-type: none"> <li>• Verify that the S/PDIF cable (optical) is firmly connected to the DCX3510-M and the home theater receiver.</li> <li>• Verify that the home theater receiver is set to a surround sound audio mode (Dolby Pro Logic®, Dolby Pro Logic II®, Dolby Pro Logic IIx®).</li> <li>• Verify that the receiver is properly configured to work with all connected speakers.</li> </ul>



Problem	Possible Solution
<p><b>There is no video on the TV screen</b></p>	<ul style="list-style-type: none"> <li>• Verify that the TV is powered on and set to the appropriate input source for the DCX3510-M.</li> <li>• Verify that the DCX3510-M is powered on and tuned to an authorized cable channel.</li> <li>• Verify that all video cables between the DCX3510-M and the TV are firmly connected.</li> <li>• Verify that the coaxial cable feed is firmly connected to the DCX3510-M and the wall jack.</li> <li>• If the DCX3510-M video output is connected to a home theater unit, verify that the home theater unit is powered on and set to the appropriate input source.</li> <li>• If the DCX3510-M video output is connected to a TV through an HDMI connection, power off the TV and then power off the DCX3510-M. Wait one second and then power on the devices.</li> </ul> <p>Not all HDTVs can display every output format (1080i, 720p, 480p, or 480i) available on the DCX3510-M.</p> <ol style="list-style-type: none"> <li>1. Ensure that your DCX3501 is plugged into a power outlet and is turned off.</li> <li>2. Press the MENU key on the remote control. Your settings are displayed on the DCX3501 front panel display.</li> <li>3. Press the ▲ and ▼ keys to display the HDMI/YPbPr OUTPUT setting.</li> <li>4. Press the ► key to cycle through the available output formats until a picture displays on the TV.</li> </ol>
<p><b>No graphics or program guides appear on the screen</b></p>	<p>If you use the IEEE-1394 connection, on screen graphics, including closed captions and program guides, are not displayed by the DCX3510-M. On-screen graphics and captions may still be overlaid by your TV, if enabled. Use HDMI or component video instead.</p>
<p><b>No closed captions display</b></p>	<ul style="list-style-type: none"> <li>• Verify on the User Settings menu that closed captions are enabled on the DCX3510-M.</li> <li>• Verify that closed captions are enabled on the TV.</li> </ul> <p><i>Note: Closed captioning may not be available on the current program.</i></p>
<p><b>There are black bars to the right and left of the picture</b></p>	<p>Widescreen TVs display 4:3 programs in this format unless set to Stretch. If the DCX3510-M is connected to a widescreen TV, verify that the TV TYPE is set to 16:9 in the User Settings menu.</p> <p>Many HD programs are broadcast in pillar-box format with black bars to the left and right of the picture. These programs are broadcast in 16:9 HD formats, even though the video is not 16:9.</p>
<p><b>There are black bars above and below the picture</b></p>	<p>All 4:3 HDTVs display HD programs in letterbox format (black bars above and below the picture) because of the shape of the display screen. Set the TV TYPE to 4:3 Pan-Scan. This enables the DCX3510-M to remove the black bars above and below the picture when possible</p> <p>Some SD programs are broadcast in the letterbox format with black bars above and below the picture. Some widescreen TVs offer a zoom feature that may be able to remove the black bars (see the TV manual for</p>



Problem	Possible Solution
	<p>information about zooming 4:3 video).</p>
<p><b>There are black bars on all four sides of the picture</b></p>	<p>This may occur on a 16:9 TV if the active video for an SD broadcast is in letterbox format. To confirm, wait for a commercial or look for a graphic, such as a network logo. If the commercial fills the screen from top to bottom, or the graphic appears below the active video, the program is being letterboxed by the broadcaster. Minimize this by activating the zoom feature on the TV.</p> <p>A broadcast may include black bars on either side of a widescreen broadcast. This is called a hybrid aspect ratio and results in a black border around the video on a 4:3 TV. Because this is part of the broadcast, the DCX3510-M cannot correct the video. You may be able to minimize the border using the zoom feature on the TV.</p>
<p><b>Colors do not appear correctly</b></p>	<p>Be sure to match up each signal to the same YPbPr connection on the TV. Otherwise, colors will not appear correctly on the TV.</p>



**MOTOROLA**

Motorola Mobility, Inc.  
101 Tournament Drive, Horsham, PA 19044 [www.motorola.com](http://www.motorola.com)

365-095-17066 x.1 04/11

