



Professional Radio

P040

User Guide

68P66533D01

Issue: April 2002



CONTENTS

Radio Overview	3
Parts of the Radio	3
On-Off/Volume Knob	4
Channel Selector Knob	4
Push-to-Talk (PTT) Button	4
Microphone	4
LED Indicator	4
Programmable Buttons	4
Indicator Tones	6
Programmable Buttons' Audio Indicators ..	6
Improved Audio Features	6
Low Level Expansion (LLE)	6
Companding	6
Getting Started	7
Battery Information	7
Battery Care and Tips	7
Recycling or Disposal of Batteries	8
Charging your Battery	8
Accessory Information	9
Attaching the Battery	9
Removing the Battery	9
Attaching the Antenna	10

Removing the Antenna	10
Attaching the Belt Clip	11
Removing the Belt Clip	11
Turning the Radio On or Off	12
Adjusting the Radio's Volume	12
Selecting a Radio Channel	12
Sending a Call	13
Receiving a Call	13
Radio Call Information	14
Repeater or Talkaround Mode	14
Setting Tight or Normal Squelch	14
Setting the Power Level	14
Scan	15
Starting or Stopping a Scan Operation ..	15
Talkback	15
Deleting a Nuisance Channel	15
Adding a Deleted Nuisance Channel back to the Scan List	16
Prioritization of a Scan List member	16

CONTENTS

Safety Information 17

CONTENTS

Computer Software Copyright

The products described in this manual may include copyrighted computer programmes stored in semiconductor memories or other media. Laws in the United States of America and other countries preserve for Motorola Europe and Motorola Inc. certain exclusive rights for copyrighted computer programmes, including the right to copy or reproduce in any form the copyrighted computer programme. Accordingly, any copyrighted computer programmes contained in the products described in this manual may not be copied or reproduced in any manner without the express written permission of the holders of the rights. Furthermore, the purchase of these products shall not be deemed to grant either directly or by implication, estoppel, or otherwise, any licence under the copyrights, patents, or patent applications of the holders of the rights, except for the normal non-exclusive royalty free licence to use that arises by operation of the law in the sale of the product.

RADIO OVERVIEW

PARTS OF THE RADIO

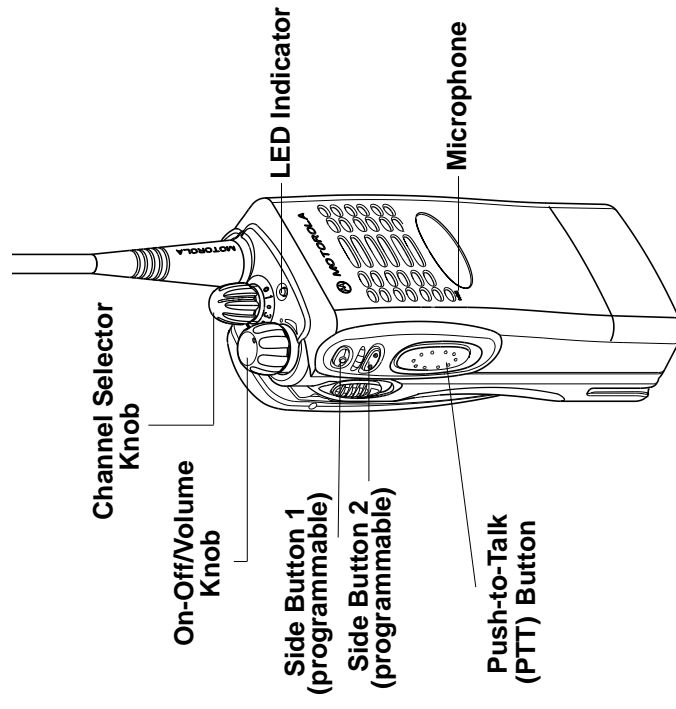

RADIO OVERVIEW

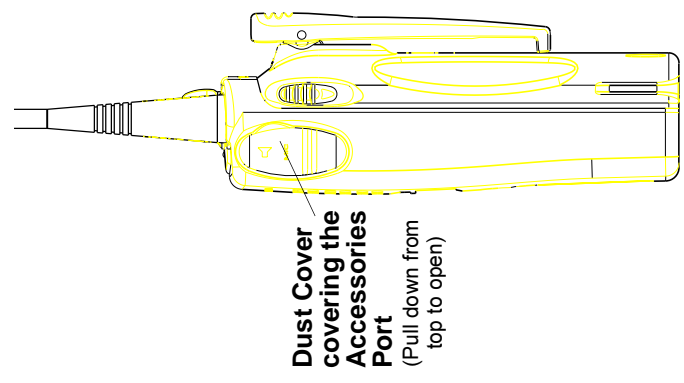

RADIO OVERVIEW

On-Off/Volume Knob

Turns the radio on or off, and adjusts the radio's volume.

Channel Selector Knob

Switches the radio to different channels.

Push-to-Talk (PTT) Button

Press and hold down to talk; release it to listen.

Microphone

Speak clearly into the microphone when sending a message.

LED Indicator

Provides visual feedback on radio status. The operation of the indicator depends upon how the radio has been programmed by your dealer.

Basic Features

LED State/Colour	Indication
Radio Call Continuous Red Blinking Red	Sending message. Receiving message.
Scan Blinking Green	Scanning for activity.
Low Battery Blinking Red when sending message	Low battery level.

Optional Transmit Power Level Indicator

LED State/Colour	Indication
Power Level Continuous Red Continuous Green	Sending message in high power. Sending message in low power.

Optional Transmit Battery Status Indicator

LED State/Colour	Indication
Battery Status (while pressing PTT) Blinking Green Continuous Green Continuous Orange Continuous Red Blinking Red	Battery is fully charged. Battery is optimally charged. Battery is half charged. Low battery level. Very low battery level.

Programmable Buttons

Your radio's two side buttons can be programmed by your dealer as short-cut buttons for many of the radio's features.

Check with your dealer for a complete list of the functions your radio's programmable buttons support.

The table below shows the functions available by

- **short press** - quickly pressing and releasing the programmable buttons, or
- **long press** - pressing and holding the programmable buttons for a period of time (programmable by your dealer) before releasing, or
- **hold down**- pressing and holding down the programmable buttons while checking status or making adjustments.

Depending on how your radio has been programmed by your dealer, these functions are activated **EITHER** through short press **OR** long press, but **NOT** both.

RADIO OVERVIEW

Button	Short Press/Long Press	Hold Down
Monitor	—	Monitors the selected channel for any activity.
Volume Set	—	Sounds a tone for adjusting the radio's volume level.
Scan	Starts or stops the Scan operation.	—
Nuisance Channel Delete	Deletes a nuisance channel while scanning.	—
Power Level	Toggles your radio's transmit power level between High and Low settings.	—
Repeater/Talkaround	Toggles between using a repeater and transmitting directly to another radio.	—
Squelch	Toggles your radio's squelch level between tight and normal settings.	—

RADIO OVERVIEW

INDICATOR TONES

High pitched tone Low pitched tone



Self Test Pass Tone



Self Test Fail Tone

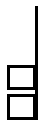

Positive Indicator Tone



Negative Indicator Tone

Button	Positive Indicator Tone	Negative Indicator Tone
Squelch	Radio operates in tight squelch	Radio operates in normal squelch
Repeater/Talkaround	Radio DOES NOT use the repeater	Radio uses the repeater

IMPROVED AUDIO FEATURES

Your radio may be programmed by your dealer to utilise ONE of the following audio enhancement features.

Low Level Expansion (LLE)

LLE improves voice quality by reducing unwanted background noise when receiving a message.

Companding

Companding improves voice quality by compressing your voice at transmission, and expanding it when receiving. Companding also reduces extraneous noise. However, to enjoy this benefit, **ALL** transmitting and receiving radios must have this feature activated.

PROGRAMMABLE BUTTONS' AUDIO INDICATORS

Some programmable keys function as toggles (alternating between two different choices). These keys use audio indicators to indicate the change.

Button	Positive Indicator Tone	Negative Indicator Tone
Scan	Start Scan operation	Stop Scan operation
Power Level	Radio transmits at high power	Radio transmits at low power

GETTING STARTED

BATTERY INFORMATION

Battery Care and Tips

This product is powered by a nickel-cadmium (NiCd) or a nickel-metal-hydride (NiMH) rechargeable battery.

The following battery tips will help you obtain the highest performance and longest cycle life from your Motorola rechargeable battery.

- Charge your new battery overnight (**14-16 hours**) before using it to obtain maximum battery capacity and performance.
- Charging in non-Motorola equipment may lead to battery damage and void the battery warranty.
- When charging a battery that is attached to the radio, turn the radio off to ensure a full charge.
- The battery should be at about 25°C (room temperature) whenever possible. Charging a cold battery (below 10°C) may result in leakage of electrolyte and ultimately, in failure of the battery.

GETTING STARTED

- Charging a hot battery (above 35°C) results in reduced discharge capacity, affecting the performance of the radio. Motorola rapid-rate battery chargers contain a temperature-sensing circuit to ensure that the battery is charged within these temperature limits.
- New batteries can be stored up to two years without significant cycle loss. Store new/unused batteries in a cool dry area.
- Batteries which have been in storage should be charged overnight.
- Do not return fully charged batteries to the charger for an "extra boost". This action will **significantly** reduce cycle life.
- Do not leave your radio and battery in the charger when not charging. Continuous charging will shorten battery life. (Do not use your charger as a radio stand.)
- For optimum battery life and operation use only Motorola brand chargers. They were designed to operate as an integrated energy system.

GETTING STARTED

Recycling or Disposal of Batteries



At the end of its useful life, the NiCd battery can be recycled. However, recycling facilities may not be available in all areas.

Motorola endorses and encourages the recycling of all re-chargeable batteries. Contact your local Motorola dealer for further information.

Charging your Battery

When the battery level is very low, a blinking red LED indicator lights up during transmit mode, and an alert tone sounds. You will need to recharge the battery before you can continue to use your radio.

Place the radio with the battery attached or the battery alone in the charger. The charger's LED indicator will indicate the charging progress.

NOTE: Since new batteries or batteries that have not been used for several months could prematurely indicate full charge (solid green LED), charge the batteries for 14 to 16 hours prior to initial use to achieve optimal performance.

LED color	Status
Single flash of Green	Successful charger power-up.
Flashing Red*	Battery is unchargeable.
Flashing Yellow	Charger is getting ready to charge.
Red	Battery is charging.
Flashing Green†	Battery is 90% charged.
Green	Battery is fully charged.

* Remove the battery from charger and use a pencil eraser to clean the four metal contacts on the bottom of the battery. Place the battery back into the charger. If the LED indicator continues to flash red, replace the battery.

† A standard battery may require one hour to charge to 90% capacity.

ACCESSORY INFORMATION

Attaching the Battery

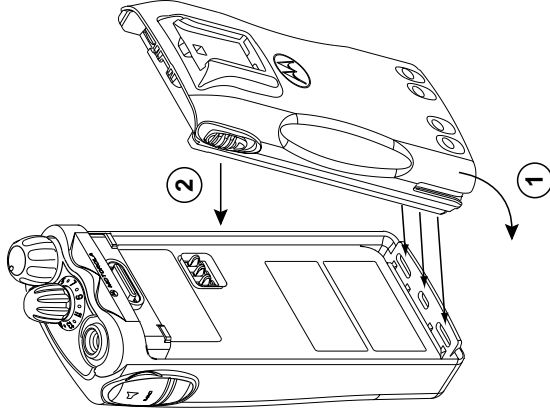

1. Fit the extensions at the bottom of the battery into the slots at the bottom of the radio's body.
2. Press the top part of the battery toward the radio until you hear a click.

Removing the Battery

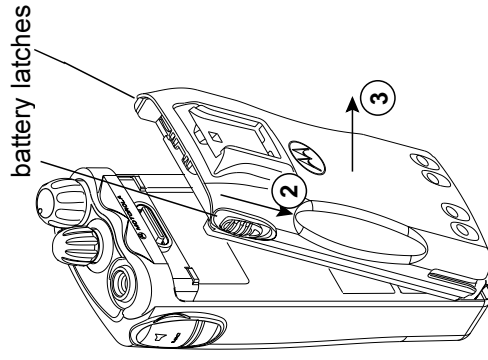

1. Turn off the radio, if it is turned on.
2. Slide the battery latches on both sides of the battery downwards.
3. Pull the top part of the battery away from the radio body.

GETTING STARTED

GETTING STARTED

Attaching the Antenna

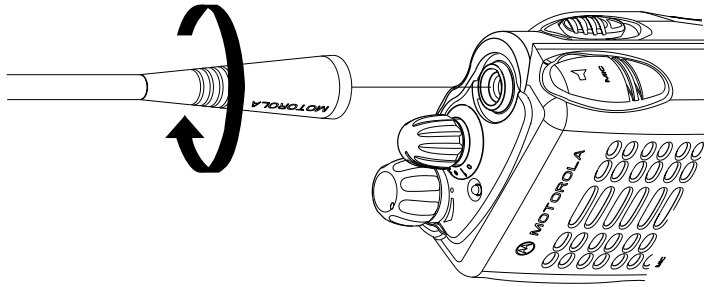

Turn the antenna clockwise to attach it.

Removing the Antenna

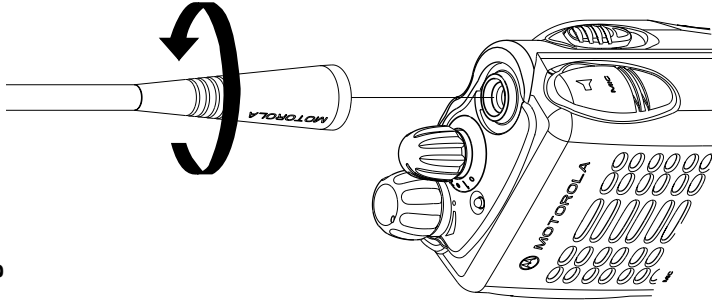

Turn the antenna counter-clockwise to remove it.

Attaching the Belt Clip

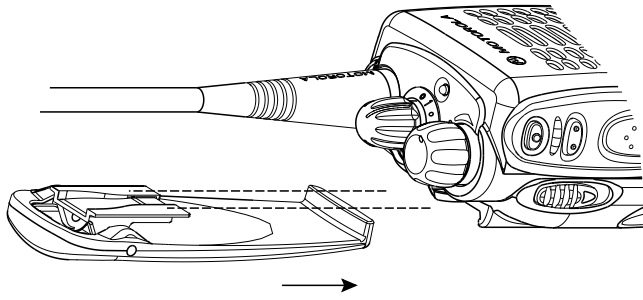

1. Align the grooves of the belt clip with those of the battery.
2. Press the belt clip downward until you hear a click.

Removing the Belt Clip

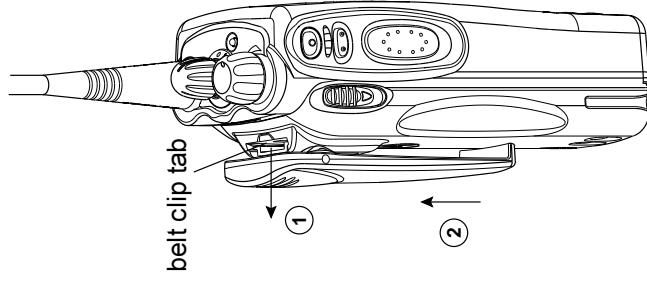

1. Use a key to press the belt clip tab away from the battery.
2. Slide the belt clip upward to remove it.

GETTING STARTED

GETTING STARTED

TURNING THE RADIO ON OR OFF

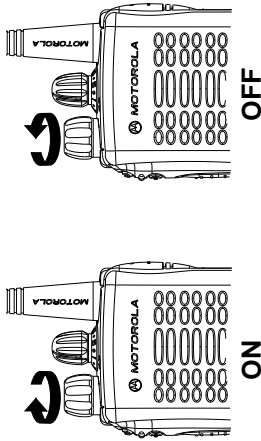

1. Turn the **On-Off/Volume Control** knob clockwise to turn on the radio. You will hear the Self Test Pass Tone () and see a green LED if the radio powers up successfully. If the radio fails its self test, you will hear the Self Test Fail Tone (). Switch off and on again and if fault persists contact your dealer.
2. To turn off the radio, turn the **On-Off/Volume Control** knob counter-clockwise, until you hear a click.

ADJUSTING THE RADIO'S VOLUME

If one of the radio side buttons has been programmed as a Volume Set button by your dealer, it may be used as follows:

1. Press and hold the preprogrammed **Volume Set** button; you will hear a continuous tone.
2. Turn the **On-Off/Volume Control** knob and adjust the volume level.
3. Release the preprogrammed **Volume Set** button.

SELECTING A RADIO CHANNEL

Your radio offers 16 channels for easy access to required conventional channels. Some channels on your radio may not be programmed. Check with your dealer for more information.

Turn the **Channel Selector** knob clockwise or counter-clockwise until you reach the desired channel.

SENDING A CALL

1. Turn your radio on.
2. Use the **Channel Selector** knob to select the desired channel.
3. Hold the radio in a vertical position, press the **PTT** button, and talk at a distance of about 2.5 to 5 cm (one to two inches) from the microphone.
4. Release the **PTT** button to listen.

RECEIVING A CALL

1. Turn your radio on.
2. Adjust the radio's volume.
3. Switch to the desired channel.
4. If at any time a call comes through, you will hear the call at the volume level you have set.

GETTING STARTED

RADIO CALL INFORMATION

REPEATER OR TALKAROUND MODE

Talkaround Mode enables you to communicate with another radio when either:

- the repeater is not operating
—or—
- your radio is out of the repeater's range but within communicating distance of another radio.

Press the **Repeater/Talkaround** button (only available if programmed by your dealer) to toggle between the two modes. A positive indicator tone indicates that the radio is in talkaround mode, while a negative indicator tone indicates that the radio is in repeater mode.

SETTING TIGHT OR NORMAL SQUELCH

Use this feature to filter out nuisance (unwanted) calls and/or background noise. However, tightening squelch could cause calls from remote locations to be filtered out as well. In this case, normal squelch may be more desirable.

Press the **Squelch** button (only available if programmed by your dealer) to toggle between tight and normal squelch. A positive indicator tone indicates that the radio is operating in tight squelch, while a negative indicator tone indicates that the radio is operating in normal squelch.

SETTING THE POWER LEVEL

Your radio has a predefined transmit power level that can be changed.

- *High power* allows the radio to transmit over greater distances.
- *Low power* conserves the battery's charge.

Press the **Power Level** button (only available if programmed by your dealer) to toggle between *low* and *high* transmit power level. A positive indicator tone indicates that the radio is in high power mode, while a negative indicator tone indicates that the radio is in low power mode.

RADIO CALL INFORMATION

SCAN

You can monitor several channels in order to receive any call that is transmitted on any of these channels.

Once the radio's scan operation is activated and the radio detects a call coming through a channel in its scan list, it switches to that channel for you to receive the call.

STARTING OR STOPPING A SCAN OPERATION

To start or stop a scan operation:

1. Press the **Scan** button (only available if programmed by your dealer) to start a scan operation. You will hear a positive indicator tone.
2. Press the preprogrammed **Scan** button again to stop the scan operation. You will hear a negative indicator tone.

NOTE: The LED indicator will blink (green) during a scan operation.

TALKBACK

If the programmable Talkback option is set, you can respond to any calls received during the scan operation by pressing the PTT before the programmed hang-time ends. Check with your dealer for details.

DELETING A NUISANCE CHANNEL

If a channel continually generates unwanted calls or noise (a "nuisance" Channel), you can temporarily remove it from the scan list by performing a *Nuisance Channel Delete* operation.

1. While the radio is on the Nuisance Channel, press the **Nuisance Channel Delete** button (only available if programmed by your dealer) until you hear a tone.
2. Release the **Nuisance Channel Delete** button. The nuisance channel is deleted.

NOTE: You cannot perform a *Nuisance Channel Delete* on a priority channel or if there is only one remaining channel in the scan list.

SCAN

ADDING A DELETED NUISANCE CHANNEL BACK TO THE SCAN LIST

1. Press the **Scan** button to stop the scan operation.
2. Press the **Scan** button again to re-start the scan operation. The Deleted Nuisance Channel is reinstated to the scan list.

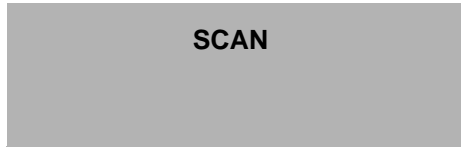

Priority Channel	Scanning Sequence
None specified	Ch1 → Ch2 → Ch3 → Ch4 → ... Ch1
Channel 2	Ch2 → Ch1 → Ch2 → Ch3 → Ch2 → Ch4 → Ch2 → ... Ch1

Even though your radio has switched to a non-priority channel, your radio will still check for activity on the priority channel. If activity is detected the radio will switch to the priority channel.

PRIORITIZATION OF A SCAN LIST MEMBER

You may want your radio to check a particular channel more frequently for calls. Prioritization of scan list members is done by your dealer using the Customer Programming Software. Check with your dealer for details.

SAFETY INFORMATION

Note: Before using this radio, refer to Important Safety and General Information contained in the separate booklet 68P64117B25_ enclosed with your radio.

SAFETY INFORMATION

NOTES

NOTES

18

English