



SABER™ Portable Radios
Radio Service Software
User's Guide

Software Part Number: RVN4002K

FOREWORD

The SABER Radio Service Software has been updated (R07.01.00) to include the following new features and capabilities:

1. Removal of Advanced Stat-Alert™ feature, Emergency Call, to free additional PL space for Advanced Stat-Alert radios only.
2. Correct problems found in R07.00.00 release software.
3. Installation of new calibration routines to allow this software to operate on computers with high clock speeds.

COMPUTER SOFTWARE COPYRIGHTS

The Motorola equipment described in this manual may include copyrighted Motorola computer programs stored in semiconductor memories or other media. Laws in the United States and other countries preserve for Motorola certain exclusive rights for copyrighted computer programs, including the exclusive right to copy or reproduce in any form the copyrighted computer program. Accordingly, any copyrighted Motorola computer programs contained in the Motorola equipment described in this manual may not be copied or reproduced in any manner without the express permission of Motorola. Furthermore, the purchase of Motorola equipment shall not be deemed to grant either directly or by implication, estoppel, or otherwise, any license under the copyrights, patents or patent applications of Motorola, except for the normal nonexclusive, royalty free license to use that arises by operation of law in the sales of a product.



TABLE OF CONTENTS

FOREWORD	<i>inside front cover</i>
COMPUTER SOFTWARE COPYRIGHTS	<i>inside front cover</i>
LIST OF FIGURES	<i>iii</i>
LIST OF TABLES	<i>iii</i>
ACRONYMS AND ABBREVIATIONS	<i>iv</i>
I. INTRODUCTION	1
A. About This Guide	1
B. Functions Performed	1
C. Customer Support	2
II. GETTING STARTED	3
A. How This Manual Is Organized	3
B. How The Screens Are Organized	3
C. How To Read The Screens	5
D. How To Use The Keyboard	6
E. The MAIN Menu	7
III. HARDWARE INSTALLATION	9
A. Host Computer and Options Required	9
B. Optional Hardware Requirement	10
C. Connecting The Radio To The Computer	10
IV. SOFTWARE INSTALLATION	12
A. How To Install The Software	12
B. How To Configure The Software For Your Computer	15
V. THE HELP SCREEN	19
VI. SERVICING THE RADIO	20
A. How to Set Up	20
B. Align Radio Parameters	22
1. Oscillator Warp	23
2. Power Level	24
3. Low Battery Threshold	25
4. Battery Save Squelch	25
5. Audio Processing	26
6. Sidetone Volume	26
7. DTMF Dial Delay	27
8. DTMF Tone ON Time	27
9. DTMF Tone OFF Time	27
10. Secure Deviation Offset	27
11. Microphone Gain	29



, Motorola, SABER, SABER IE, Private-Line, Digital Private-Line, Quik-Call, Quik-Call II, MDC-600, MDC-1200, Stat-Alert, and Handie-Talkie are trademarks of Motorola, Inc.
IBM PC/XT/AT and Personal System 2 are registered trademarks of International Business Machines Corporation.

C.	Align Channel Parameters	30
1.	Squelch.....	31
2.	VCO and Reference Modulation Alignment	32
3.	Battery Save Enable.....	33
D.	Align Scan Controls.....	33
1.	Scan Monitor Hold Time.....	34
2.	Scan Receive Response Time.....	35
3.	Scan Transmit Response Time	35
4.	Scan Priority Squelch	36
VII.	GET/SAVE/PROGRAM CODEPLUG	
	DATA FROM/TO DISK/CODEPLUG.....	37
A.	The READ function	38
B.	The WRITE function.....	39
C.	The LOAD/SAVE/DELETE functions	42
VIII.	CHANGE/CREATE/VIEW RADIO PERSONALITY	44
	View Radio Personality.....	45
A.	F3: CREATE Radio Personality File.....	46
B.	Radio Feature Options	48
C.	Channel Information.....	54
D.	Auto Dial / Access and Hangup Codes	60
E.	Manual Interconnect Access and Hangup Codes	61
F.	Format Scan Lists	62
G.	Format Selectable PL.....	64
IX.	PRINT RADIO PERSONALITY	65
APPENDIX -1	ERROR MESSAGES	67
APPENDIX -2	KEYBOARD COMMANDS.....	69
APPENDIX -3	HOW TO FORMAT A DISK.....	70
APPENDIX -4	SABER MODELS.....	71
APPENDIX -5	OPTIONS LIST AND DEFINITIONS	72
APPENDIX -6	QUIK-CALL II FREQUENCIES AND CODES	85
APPENDIX -7	SQUELCH CODES	89
GLOSSARY	90
INDEX	96

LIST OF FIGURES

FIGURE	TITLE	PAGE
1	Radio Service Software Program Tree	4
2	Screen Display Format	5
3	MAIN menu	7
4	Connecting the Radio to the Computer.....	10
5	Setup Computer Configuration	15
6	PC Configuration.....	16
7	Configure Screen Colors.....	17
8	Test Setup for Alignment Procedure	20
9	Service/Alignment Menu	21
10a	Align Radio Menu 1.....	22
10b	Align Radio Menu 2.....	22
11	Align Channel Menu.....	30
12	Align Scan Menu.....	33
13	Get/Save/Program Menu	37
14	Read Radio Display	38
15	Write Data to Radio.....	40
16	Extraction of Radio Alignment Data	41
17	Save RPF Display.....	43
18	Change/Create/View Codeplug Menu	44
19	View Radio Information Menu	45
20	CREATE RPF Menu	46
21	Options Screen	48
22	Quik- Call II System Selection Screen	51
23	Quik -Call II H701 Parameters Screen.....	52
24	Quik- Call II H702 Parameters Screen.....	52
25	Quik- Call II H703 Parameters Screen.....	53
26	Multiple Repeater Access Codes Screen	53
27	Channel Information Screen	54
28	Wide View Screen.....	58
29	Autodial Setup Screen	60
30	Manual Telephone Interconnect Screen	61
31	Create/Modify Scan Lists Screen.....	62
32	Create/Modify Selectable PL Codes	64
33	Print Menu.....	65

LIST OF TABLES

TABLE	TITLE	PAGE
1.	Motorola System.....	85
2.	General Electric System	86
3.	Plectron System.....	87
4.	Federal System.....	88

ACRONYMS and ABBREVIATIONS

ASCII:	American Standard Code for Information Interchange.
COM 1 & COM 2:	The logical names of the two serial ports available on IBM PC computers (if the computer is so equipped.)
CSQ:	Carrier Squelch.
DOS:	Disk Operating System, or Data Operated Squelch.
DPL:	Digital Private Line.
DTMF:	Dual Tone Multi-Frequency.
DVP:	Digital Voice Protection.
EEPROM:	Electrically Erasable Programmable Read Only Memory.
EPROM:	Electrically Programmable Read Only Memory.
LED:	Light Emitting Diode.
MDC:	Motorola Digital Communications:
PC:	Personal Computer.
PL:	Private Line.
PTT:	Push To Talk.
RAM:	Random Access Memory.
RAT:	Repeater Access Tone.
RIB:	Radio Interface Box.
RPF:	Radio Personality File.
RSS:	Radio Service Software.
TOT:	Time Out Timer.
TPL:	Tone Private Line Squelch.
UHF:	Ultra High Frequency.
VCO:	Voltage Control Oscillator.
VHF:	Very High Frequency.

I. INTRODUCTION

A. About This Guide

The SABER portable radio contains a new generation of advanced integrated circuits with all rf and signalling parameters controlled by the radio's microprocessor. This Radio Service Software package is required to perform all alignment adjustments on the radio. The SABER radio does not contain any internal adjustable components (i.e. coils, pots, etc...). This guide gives you step-by-step procedures that teach you how to use this software product to program and align SABER radios. The radio models supported by this field programmer are explained in Appendix -4.

Instructions for the following tasks are provided in this guide :

- The Help Screen
- Servicing The Radio
- Get/Save/Program Codeplug Data From/To Disk/Codeplug
- Change/Create/View Radio Codeplug Data
- Print Codeplug Data
- Setup Computer Configuration

The file that is created, loaded from a database, saved to a database, or modified, refers to a data file called the Radio Personality File that contains the customer personality information. Database, here, refers to a computer storage media such as a hard disk drive or a floppy disk. The data files are stored in, or retrieved from the database using the factory order number or any other name as the file name.

This user's manual has been written for the SABER Radio Service Software and provides detailed explanations on how to use this software package. Files that are programmed into radios can also be read back to review the personality of the radio. This capability can be valuable as an aid to generate an order for more of the same type of radio if no hard copy of the original order is available. As an added benefit, the system serves to automatically archive the files, if stored, for future reference or for the generation of new orders.

B. Functions Performed

The SABER Radio Service Software package will allow you to accomplish the following functions:

- HELP provides information regarding the current menu or highlighted data field. General information is available for the keyboard, print, and others.
- SERVICE radio, provides a multi-level menu that permits access to radio and channel alignment, service aids, and board replacement.

- GET/SAVE/PROGRAM codeplug data from/to disk/codeplug is used to read codeplug data from disk or a radio and/or program/save the modified codeplug data back to disk or to the radio.
- CHANGE/CREATE/VIEW radio codeplug, provides a multi-level menu that is used to change, create, or view codeplug features and option configurations.
- PRINT will print the radio personality present in the current Radio Service Software. A printer is required and should be connected to the LPT1 parallel port of an IBM PC.
- SETUP COMPUTER CONFIGURATION will configure your SABER Radio Service Software to your particular application and computer.
- EXIT will leave the Radio Service Software and return to DOS.

C. Customer Support

If you encounter a problem, first review your hardware setup (Section III-C.) and the information provided on Error Messages in Appendix -1.

Problems requiring additional analysis will be referred to the appropriate Area FTR (Field Technical Representative) group for investigation. Radio Service Software problems will be handled by the Area FTR manager within standard MOTOROLA C&E procedures for the resolution of technical product problems.

II. GETTING STARTED

A. How This Manual Is Organized

This section called GETTING STARTED, describes how to hook up the radio to your computer and how to install the software. The operation of the software is described, including how to read the screens, the keyboard commands, and how the screens are organized.

The MAIN MENU and all available Radio Service Software functions are described in detail. In the remaining three sections, the SERVICE ALIGNMENT procedures, the GETTING, SAVING, and PROGRAMMING of codeplug data from/to disk/codeplug, the CHANGING, CREATING, and VIEWING of radio codeplug, and PRINTING of codeplug, are described respectively.

All Radio Service Software screens are depicted in this manual and the operation of each one is described in detail. A description of each data field as well as function key descriptions are also given.

A GLOSSARY and APPENDIX are included for definitions, descriptions of error codes, the database structure format, keyboard commands, radio options descriptions, and other helpful information.

B. How The Screens Are Organized

The Radio Service Software screens are organized in a tree, as shown in Figure 1. One cannot randomly jump from one screen to another, but must move up and down the branches by using the menu screens and function keys.

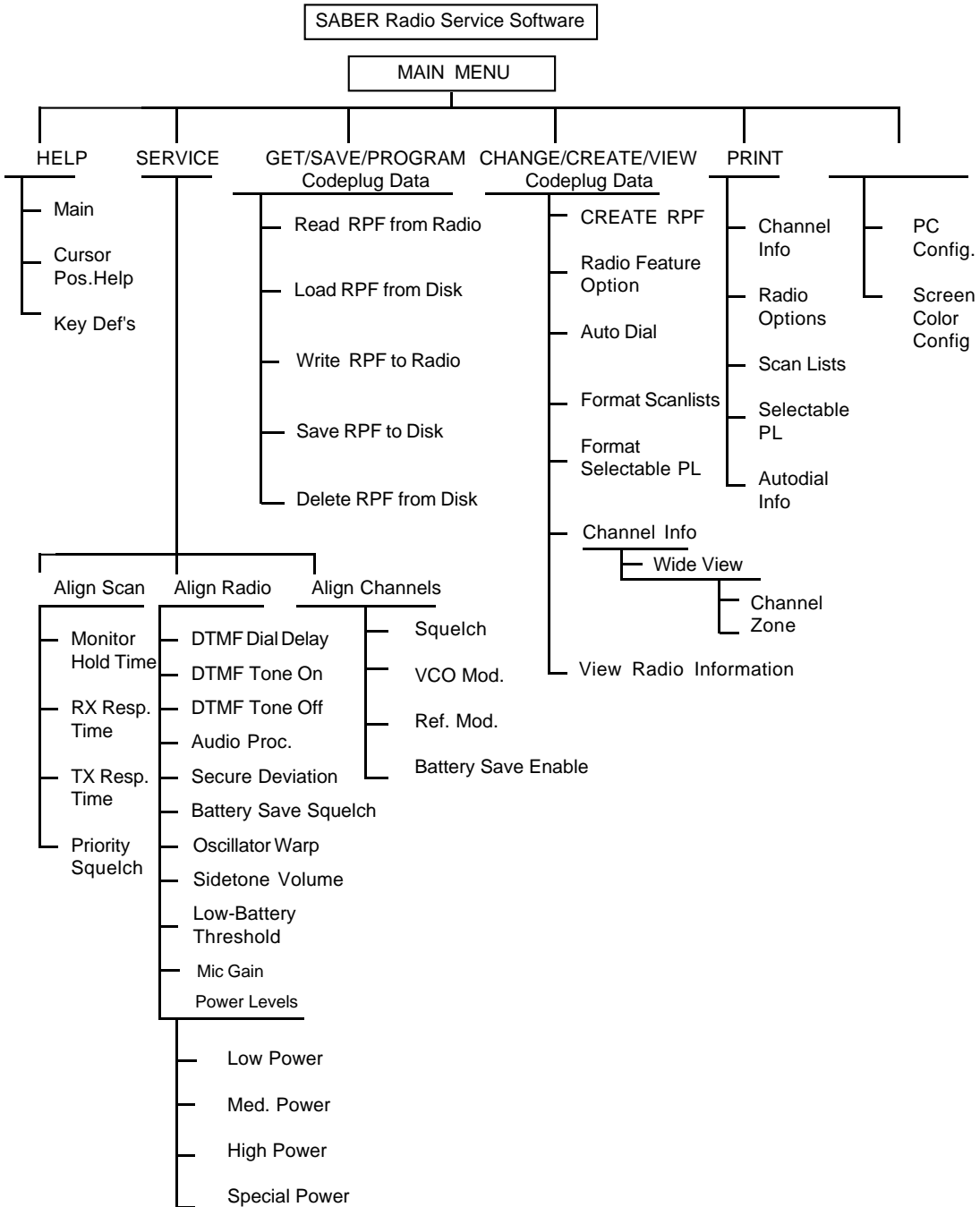

Figure 1. Radio Service Software Program Tree

C. How To Read The Screens

Every action of the Radio Service Software is controlled through the use of formatted screen displays and the function keys on your keyboard. The function keys are the ten keys located on the left side or along the top of your keyboard marked F1 - F10.

Figure 2 illustrates the screen format used by the Radio Service Software. Each screen is divided into four areas: Screen Identification Area, Screen Messages Display Area, Screen Data Entry/Display Area, and Function Key/Selection Display Area.

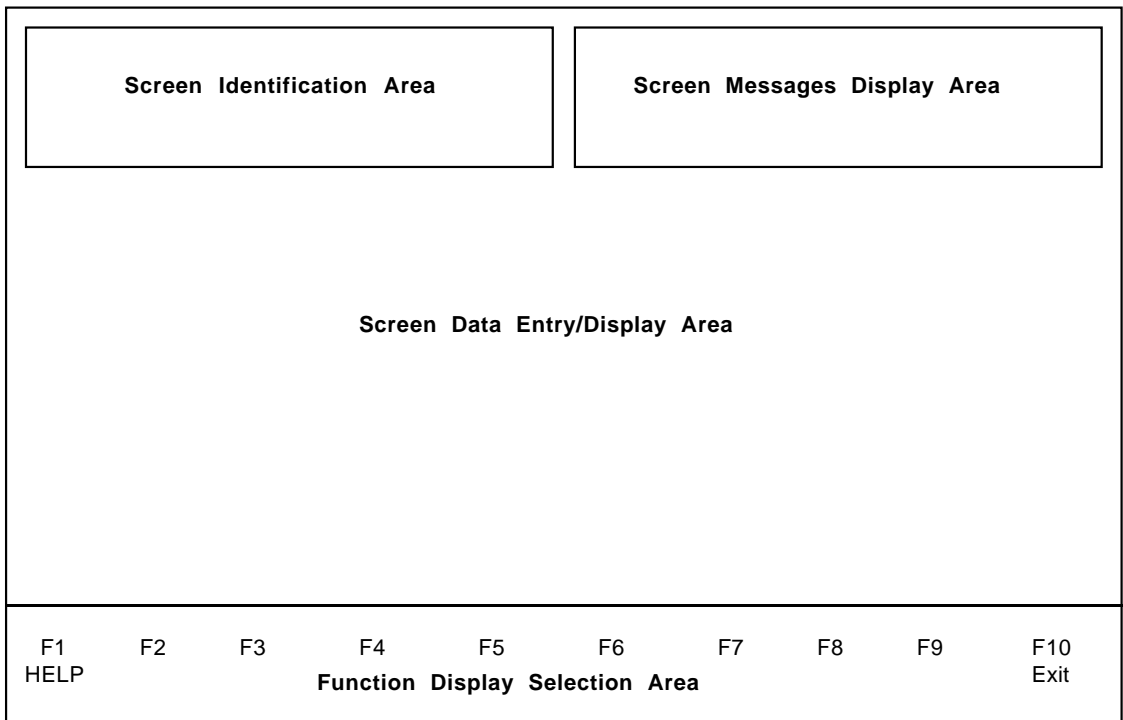

Figure 2. Screen Display Format

The Screen Identification Area is the upper left area of the screen display and is sub-divided into four sections as follows:

- The first line displays MOTOROLA Radio Service Software.
- The second line displays the SABER radio name and the model number.
- The third line displays the current version number.
- The last line is the MENU PATH. This displays the path the user took to reach the current screen display.

The **Screen Message Display Area** is in the upper right area of the screen and is further divided into two sections as follows:

- **Instruction Messages :** This message informs you of the next course of action or provides the range of acceptable values for the current data entry field.
- **Status/Error Messages:** Status messages will inform you when the software is performing non-interactive functions. The Error message informs you that an error has occurred and how to correct the error condition.

The **Screen Data Entry/Display Area** is the center part of the display screen where all menus, data entry, and display of information takes place.

The **Function Key/Selection Display Area** is the bottom area of the display screen and shows the function keys F1 - F10 with an abbreviated description of each key's function. If a key has no use, no text appears beneath the function key title.

D. How To Use The Keyboard

All Radio Service Software keyboard commands are summarized in this section. These function keys are applicable to changing screens, entering data, and moving between data fields. The F1 HELP function also provides keyboard information. From any screen, you may view this list by pressing F1 (HELP) and then pressing F2 (KEYBOARD HELP).

F1:	Help Information
F2 - F9:	Execute Labeled Function
F10:	Return to the PREVIOUS Menu
ESC:	Return to the MAIN Menu
TAB (or ENTER) :	Advance Cursor to Next Data Field
Shift TAB:	Backup Cursor to Last Data Field
UP / DOWN Arrow Keys:	Increment / Decrement Value or Selection
Shift UP / DOWN Arrow Keys:	Increase the Increment / Decrement Speed
LEFT / RIGHT Arrow:	Move Cursor Within Data Field
INSERT:	Insert Space at Current Cursor Position
BACKSPACE:	Erase Character to the left of Cursor
DELETE:	Erase Current Character
HOME:	Move Cursor To Upper Left Data Field
END:	Move Cursor To Lower Right Data Field
PAGE UP / PAGE DN:	Change Displayed Page

E. The MAIN Menu

The MAIN Menu (Figure 3) is the top level of the program tree as previously shown in Figure 1. The Radio Service Software provides five basic functions which are selected from the MAIN Menu:

- **SERVICE: Alignment, Service Aids, Board Replacement**
- **GET/SAVE/PROGRAM Codeplug Data From/To Disk/Codeplug**
- **CHANGE/CREATE/VIEW Radio Codeplug Data**
- **PRINT Codeplug Data**
- **SETUP Computer Configuration**

MOTOROLA Radio Service Software SABER Model: Ver. R07.01.00 Main	Select Function Key F1 - F10								
<u>MAIN MENU</u>									
F1 - HELP F2 - SERVICE: alignment, service aids, board replacement F3 - GET/SAVE/PROGRAM codeplug data from/to disk/codeplug F4 - CHANGE/CREATE/VIEW radio codeplug data F5 - PRINT codeplug data F6 F7 F8 F9 - SETUP Computer Configuration F10 - EXIT									
F1 HELP	F2 ALIGN	F3 READ WRITE	F4 CREATE	F5 PRINT RPF	F6	F7	F8	F9 SETUP	F10 EXIT

Figure 3. MAIN Menu

After making a selection via the function keys, you will be directed to similar sub-menus and/or data entry screens. From any point in the program, you may always return to the MAIN Menu by pressing the ESC (Escape) key.

Each programmer function is described briefly in the remainder of this section.

F1 The **HELP** function gives specific information regarding the current menu or highlighted data field. By pressing F1, the help menu screen will be generated in which F1 provides you general help, F2 provides keyboard help, F5 prints out a hard copy of the help screen, and F9 prints "other" help, or help related to a particular menu.

All HELP functions are explained in detail in Section V.

F2 The **SERVICE** function allows you to access alignment parameters in which sub-menus are provided in order to ALIGN RADIO, ALIGN CHANNEL, or ALIGN SCAN CONTROLS.

All SERVICE functions are explained in detail in Section VI.

F3 The **GET/SAVE/PROGRAM CODEPLUG DATA FROM/TO DISK/CODEPLUG** function provides all disk and codeplug interfacing. You may either choose from a READ/WRITE RADIO sub-menu, or a LOAD/SAVE/DELETE Codeplug From Disk sub-menu. The READ function will read the present radio codeplug data from the radio and generate a field programmer PC file. The WRITE function actually generates the codeplug data and writes the present radio personality into the EEPROMS in the radio. The LOAD/SAVE and DELETE RADIO CONFIGURATION DATA is used to Read codeplug data from an archived codeplug image on a diskette or hard disk for editing purposes (via create/change/view function). The LOAD/SAVE is also used to Save a modified codeplug image back onto the diskette (or hard disk) or to delete a file from disk.

All GET/SAVE/PROGRAM functions are explained in detail in Section VII.

F4 The **CHANGE/CREATE/VIEW RADIO CODEPLUG DATA** allows all editing of the radio personality features such as creating, changing, or merely viewing the current radio codeplug data.

All CHANGE/CREATE/VIEW functions are explained in detail in Section VIII.

F5 The **PRINT** function produces permanent hard copy records of codeplug configurations. A printer is required and should be connected to your computer per your instruction manual.

All PRINT functions are explained in detail in Section IX.

F9 The **SETUP COMPUTER CONFIGURATION** function is used to configure your SABER Radio Service Software to your particular application. Default disk drives, communication ports, etc... may be customized to your specific needs.

All SETUP COMPUTER CONFIGURATION functions were explained in Section IV-A.

F10 The **EXIT** function is used to quit the present program and return to the previous menu. Be sure all desired codeplug changes have been programmed back to the radio, and that an archive copy has been made. Otherwise all changes will be lost since returning to DOS erases this data from the computer's memory.

III. HARDWARE INSTALLATION

A. Host Computer And Options Required

The following section provides the hardware and software requirements needed to run the SABER Radio Service Software .

Computer:

- IBM PC or CONVERTIBLE
- IBM-XT
- IBM-XT/286
- IBM-AT
- IBM-PS/2: Models 25, 30, 50, 60, 70, or 80

Memory Required:

At least 640k bytes of RAM.

Operating System:

The software requires the DOS Version 3.1 or later to run this package.

Disk Storage:

The software will be available on both 3 1/2" and 5 1/4" (RVN-4002H) media and must be installed onto a hard disk drive. However, you can also store the data files on either 3 1/2" and 5 1/4" disks.

Communication Card:

A serial port is also required if personality files are to be read from or written to a radio. The serial port must be compatible with the IBM asynchronous communications adapter.

Printer:

A parallel interface IBM compatible printer is required if you plan to use the print facilities of the software.

Monitor:

A monochrome or color monitor compatible with the IBM monochrome display or IBM CGA/EGA adapter is required.

B. Optional Hardware Requirements

Additional hardware will be required if it is necessary to read, program, or align a SABER radio. The following section provides a list of required hardware.

Only **one** of the two cables is required. Choose the appropriate one for your machine.

- Computer Interface Cable (25-pin connector cable): #30-80369B71
- Computer Interface Cable (9-pin connector cable): #30-80369B72

Radio Interface Box (RIB): #RLN-4008A

RIB Power Supply: #01-80357A57 (110V)
#01-80358A56 (220V)
#60-82728J01 (9V)

Programming Cable: #RTK-4203A

For Alignment: (See items listed in your SABER Service Manual)

- Power Meter
- RF Monitor
- Frequency Generator (10 Hz - 10 kHz)
- Battery Eliminator: #RTL-4224A
- Portable Products Test Set: #RTX-4005B

C. Connecting The Radio To The Computer

The SABER radio and the Radio Interface Box (RIB) should be connected to the computer as described below. Refer to Figure 4.

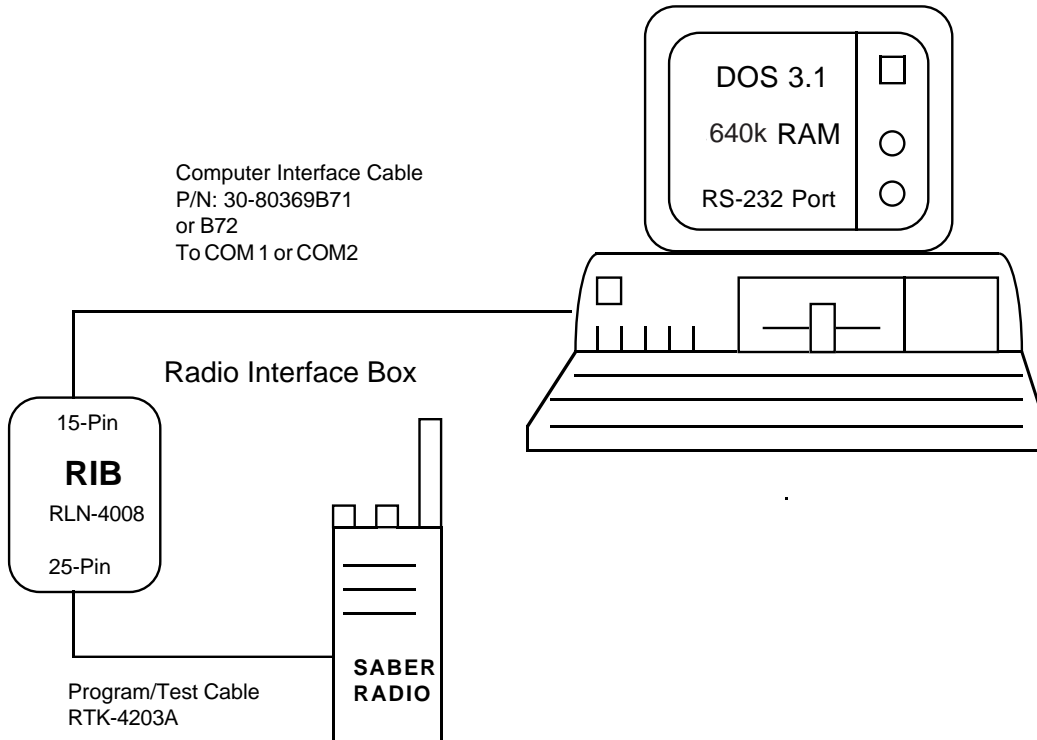

Figure 4. Connecting the Radio to the Computer

1. Shut off your computer system before connecting anything to it.
2. Connect one end of the RS-232 cable to the IBM PC (the cable is marked to show you which end plugs into the computer). Connect the other end of the cable into the RIB.
3. Connect the RIB power supply to the RIB and plug the power cord for the RIB into a power outlet.
4. Connect the programming cable into the other end of the RIB. (The programming cable has four terminations but only one will fit into the RIB.) On the same end of the programming cable as the RIB termination are three other terminations - a round multi-pin connector, a male BNC type RF connector and a female BNC connector.
5. Attach the male BNC RF connector to a power meter for RF power level measurements, or an rf monitor for deviation measurements. **Note** that if you use an extension coax cable to connect the BNC connector to the appropriate test equipment, you will need to take into account the rf losses in that extension cable when setting rf power.
6. Connect the round multi-pin connector to the RTX-4005B connector. Use a portable products test set (or the RTX-4005A test set which has been equipped with the RPX-4665A Field Mod kit). Select the A position (which is the SABER position) on the test set.
7. Connect the female BNC connector to an audio generator capable of generating frequencies from 10 Hz to 10 kHz.
8. Remove the battery from the radio (which is turned off) and attach the battery eliminator for the SABER radio, to the radio under test. Connect the battery eliminator to a 5A, 10V power supply. Set the power supply to 7.5 +/- 0.1 VDC.
9. Connect the programming cable to the back connector on the radio.
10. Load the SABER Radio Service Software into the computer.
11. Turn the radio on.
12. Later, if you wish to align the radio you must first program the radio to the personality that is required in the radio. If the radio has already been programmed, then you must first read the personality of the radio or from disk before you can align it. In either case, a radio personality file must exist in the work space before the system will allow you to access the ALIGN menu from the SERVICE screen.

If you had read the personality of the radio, then you must turn the radio off and then back on prior to aligning it. The system will not allow you to align the radio if the radio is in the programming mode. For display models, the radio is in the programming mode if the radio LCD displays the message, ERR x yz (See Appendix -1 on Error messages). Turning the radio off, and then back on, will take the radio out of the programming mode. If the message is still there, then see what type of hardware problem has occurred according to the type of error message as stated in Appendix-1.

IV. SOFTWARE INSTALLATION

A. How To Install The Software

The Radio Service Software is shipped to you on either two 5 1/4" floppy disks (labeled PROGRAM DISK 1 and PROGRAM DISK 2) or one 3 1/2" disk (labeled PROGRAM DISK 1). The software has been designed to give optimum performance while running on a hard disk, but may be used on a machine with dual-floppy drives. If you have a hard disk, skip to the next section.

WHILE THE SABER RADIO SERVICE SOFTWARE IS OPERATING IN THE PC ENVIRONMENT, IT KEEPS SEVERAL FILES OPEN IN THE SYSTEM AT THE SAME TIME.

THE DOS ENVIRONMENT BY DEFAULT LIMITS THE NUMBER OF FILES THAT CAN BE OPENED AT ANY ONE TIME TO 8. THIS IS NOT SUFFICIENT TO RUN THE SABER RADIO SERVICE SOFTWARE.

IN ORDER TO INCREASE THE NUMBER OF FILES THAT CAN BE OPENED AT ANY ONE TIME, IT IS NECESSARY TO DEFINE THIS IN YOUR CONFIG.SYS FILE.

IF THE CONFIG.SYS FILE CURRENTLY EXISTS IN YOUR SYSTEM, IT IS THEN ONLY NECESSARY TO EDIT THE EXISTING FILE TO ADD THE FOLLOWING LINE.

FILES = 20

IF CONFIG.SYS DOES NOT CURRENTLY EXIST IN YOUR SYSTEM, IT WILL BE NECESSARY TO CREATE ONE WITH THE SAME LINE AS ABOVE.

REFER TO YOUR DOS MANUAL FOR FURTHER INFORMATION.

Hard Disk Installation Procedure

If you are using a hard drive system, use the installation program on Diskette 1 to install the RSS properly on your hard disk. To run the install program, set the current disk drive to a floppy drive and insert Diskette 1. At the > prompt, type:

INSTALL <Enter>

and follow the directions given on the screen. The Install program will check for the existence of the hard disk specified, that sufficient free disk space exists on the hard disk, and if the subdirectories exist before attempting to create them.

After the installation is complete, move to either the root directory of the hard drive or to the **\RSS\SABER** sub-directory and type:

SABER <Enter>

This will start the SABER RSS software.

After typing in SABER, the first screen that will come up on your computer is shown below:

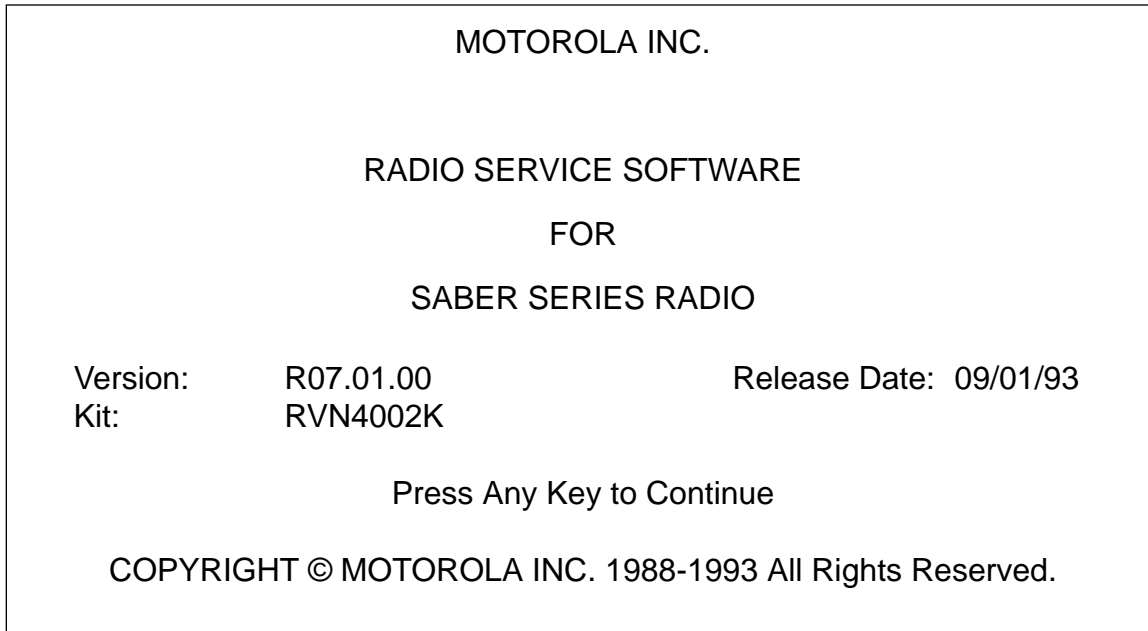

Now continue to Section IV-B to complete the configuration procedure.

B. How To Configure The Software For Your Computer

The first time the Radio Service Software is installed on a floppy disk system or the hard disk system, the program will initially respond with the MAIN menu. To configure your computer press F9 for SETUP Computer Configuration Menu. The screen as shown in Figure 5 will come up. The SERVICE SOFTWARE CONFIGURATION Menu has several system options that need to be setup in your configuration file. This procedure only needs to be setup once when installing the system. Each function key is explained below in order to configure your computer completely.

MOTOROLA Radio Service Software SABER Model: Ver. R07.01.00 Main.Setup	Select Function Key F1 - F10								
<u>SETUP COMPUTER CONFIGURATION MENU</u>									
F1 - Help for Computer Setup F2 F3 - PC Configuration: Drives, Paths, Ports, etc... F4 F5 F6 F7 - Screen Color Configuration F8 - F9 F10 - EXIT									
F1 HELP	F2	F3 PC CONFIG	F4	F5	F6	F7 SCREEN COLOR	F8	F9	F10 EXIT

Figure 5. Setup Computer Configuration

F3 - PC Configuration: Drives, Paths, Ports, etc...

PC Configuration is important in running the SABER Radio Service Software. When F3 is selected, the screen shown in Figure 6 will come up. Each data field can be selected by pressing the ENTER key and entering the proper data for that field. "Toggle" selection is made only on the last entry in which the UP/DOWN arrow keys will toggle between the two data fields listed.

MOTOROLA Radio Service Software SABER Model: Ver. R07.01.00 Main.Setup.PC	Enter Drive								
<u>PCCONFIGURATION</u>									
Archive drive: A									
Archive path: RSS\SABER\Data									
Serial Port: COM 1									
F1 HELP	F2	F3	F4	F5 PRINT	F6	F7	F8 SAVE	F9 RESET DEFAULT	F10 EXIT

Figure 6. PC Configuration

Use the following steps to configure your computer:

1. Enter the **Archive Drive**, or default disk drive where you plan to keep your archive files. For example, if you have a hard disk system and want to save archive files on a floppy disk in drive A:, enter:

A:

for the Archive Path Name. Press ENTER to continue.

For a floppy disk system, you must enter disk drive B: if you have SABER.EXE in drive A and MOTOROLA.LBR in drive B.

2. Next, you must enter the **Archive Path** which is the path name of the archive disk where all archive files will be kept. On the Screen "\Data" is shown but you may call this directory any name you wish. Remember to create a directory called "Data" if you enter this directory name for the Archive Path.

3. Use the UP/DOWN arrow keys to select Asynchronous Communications **Serial Port** COM 1 or COM 2.
4. To complete the PC computer configuration, press F8 to SAVE the configuration information to a file on the program disk. Every time you use the Radio Service Software, the configuration that you SAVED last will be used. At anytime the configuration may be changed and SAVED.

All selections may be reset to the original values by pressing the F9 (RESET DEFAULT) function key. Note RESET DEFAULT does NOT save the configuration. If the default values are desired, you must still save them by pressing F8 for SAVE in the Setup Computer Configuration Menu. If you do not SAVE, the values in place when you exit the Configuration screen will persist until you exit the program, or change them again.

5. If you have a color monitor, continue with F7 - Screen Color Configuration. Otherwise, this completes the software installation procedure.

F7 - Screen Color Configuration

Follow the steps below to configure your screen for the various color options. Press the F7 function key to access the SCREEN COLOR CONFIGURATION screen as shown in Figure 7, to enable the color display option and configure your screen colors.

MOTOROLA Radio Service Software SABER Model: Ver.R07.01.00 Main.Setup.Colors	Use UP and DOWN arrow keys to select																				
CONFIGURE SCREEN COLORS Is this COLOR or B & W? -COLOR Color for Normal Text and Input Data... Color for Headings..... Color for Error Messages..... Color for Status Messages..... Color for Input Prompts..... Color for Highlighted Data..... Color for HELP Messages..... Color for Screen Border..... Color for Screen Background.....																					
<table style="width: 100%; border: none;"> <tr> <td style="width: 10%;">F1</td> <td style="width: 10%;">F2</td> <td style="width: 10%;">F3</td> <td style="width: 10%;">F4</td> <td style="width: 10%;">F5</td> <td style="width: 10%;">F6</td> <td style="width: 10%;">F7</td> <td style="width: 10%;">F8</td> <td style="width: 10%;">F9</td> <td style="width: 10%;">F10</td> </tr> <tr> <td>HELP</td> <td>CHANGE COLOR</td> <td>TOGGLE BLINK</td> <td>TOGGLE BRIGHT</td> <td>INVERSE VIDEO</td> <td></td> <td></td> <td>SAVE CONFIG</td> <td>RESET DEFAULT</td> <td>EXIT</td> </tr> </table>		F1	F2	F3	F4	F5	F6	F7	F8	F9	F10	HELP	CHANGE COLOR	TOGGLE BLINK	TOGGLE BRIGHT	INVERSE VIDEO			SAVE CONFIG	RESET DEFAULT	EXIT
F1	F2	F3	F4	F5	F6	F7	F8	F9	F10												
HELP	CHANGE COLOR	TOGGLE BLINK	TOGGLE BRIGHT	INVERSE VIDEO			SAVE CONFIG	RESET DEFAULT	EXIT												

Figure 7. Configure Screen Colors

In order to configure your screen coloring, first set the monitor type: **COLOR** or **B & W** (black and white). Use the UP/DOWN arrow keys to toggle between the two options of either color or black and white. Press ENTER to move to the next selection. If you wish to skip any selections continue to press the ENTER key until you find the selection you want to modify.

Each selection listed can be configured with the function keys at the bottom of the screen except for SCREEN BACKGROUND. This parameter can only be modified with the F2 key or CHANGE COLOR. The screen background can have one of eight colors and cannot change its brightness, like the other selections.

Function Key Descriptions:

- F2 **Change Color**** - There are eight different colors to select from which you can select by pressing the F2 key, continue to press this key to scroll through the different colors.
- F3 **Toggle Blink**** - This function toggles the selected item to blink on and off. To disable the blinking, just press the F3 key again.
- F4 **Toggle Bright**** - This function toggles the brightness or intensity of the selected color in F2. This key just toggles between the original color and another intensity of the same color.
- F5 **Inverse Video**** - This function allows you to switch the colors of the background of the message and the actual character letters of the message. This key just toggles between the character letters and the background color of the message.
- F8 **Save Config**** - This function saves the options selected on this CONFIGURATION SCREEN COLORS menu. It is necessary to save these options each time you change or modify any of the selections.
- F9 **Reset Default**** - This function resets the screen back to its original state or default settings. The default screen is the original screen that comes up once this menu is selected from the SETUP Computer Configuration menu.

The last step in configuring your computer is to save the values using the F8 key. Press F10 to return to the SETUP Computer Configuration menu, or ESC to return to the MAIN menu.

V. THE HELP SCREEN

Help is available from the MAIN menu and any sub-menu with the F1 function key. The HELP function gives specific help regarding the current menu or highlighted data field. The help menu screen provides you with three types of help:

- F1** - From the HELP function, general information is available by pressing this function key.
- F2** - This function key provides help on the different function keys pertinent to the particular screen shown.
- F5** - PRINT help will create a hard copy of all help information shown on the screen.
- F9** - Other help provides additional help on such things as radio serial number, software version numbers, cable numbers, etc...

F10 exits the help menu and brings you back to the previous menu. If all the information cannot fit on one screen, use the PgUp and PgDn keys to page through or page back all available help information. To indicate the exact size of the particular document or "help" information, the screen identification area in the upper left corner of the screen states "Page X of Y," where "Y" is the total number of pages and "X" is the present page number.

VI. SERVICING THE RADIO

All radio alignment procedures are accessed from the SERVICE menu. A radio must be connected to your computer via a RIB and cables, and the radio turned ON before you will be permitted to access the SERVICE screens. Refer to the SABER SERVICE AIDS list in Appendix-7 for all the service aids, service tools, and recommended test equipment that you may require to program, align, and test SABER radios.

All SERVICE screens do NOT read and program the radio codeplug directly, you have to use the READ/WRITE functions before and after using the SERVICE menus.

A. How To Set Up

For setting up to align the radio, follow the procedure in Section III-C: Connecting the Radio To The Computer, except use the general hardware test equipment shown in Figure 8 for aligning.

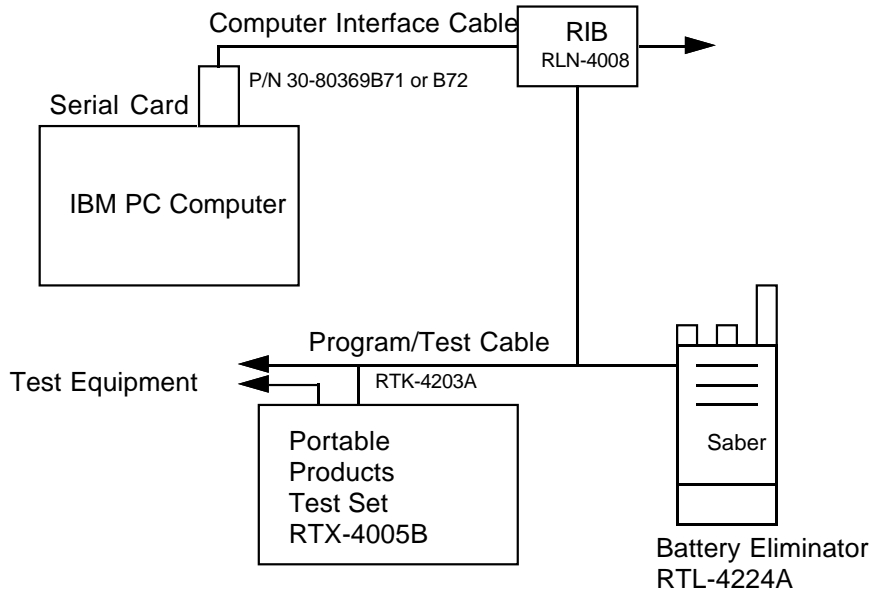

Figure 8. Test Setup for Alignment Procedure

Once you are ready to begin the alignment process, select the SERVICE function (F2) in the MAIN menu. Once selected, the system will bring up the screen shown in Figure 9. You will see three menu selections on this screen for Align Radio, Align Channel, and Align Scan. Press the appropriate function key and a sub-menu will come up with all the available alignment parameters. Sections VI-B, VI-C, and VI-D explain in detail the function and procedure for aligning the radio, channels, and scan controls.

MOTOROLA Radio Service Software SABER Model: Ver. R07.01.00 Main.Align.	Select Function Key F1 - F10								
<u>SERVICE / ALIGNMENT MENU</u>									
F1 - Help on Alignment F2 F3 - Align Radio Parameters F4 - Align Channel Parameters F5 - Align Scan Controls F6 F7 F8 F9 F10 - EXIT									
F1 HELP	F2	F3 ALIGN RADIO	F4 ALIGN CHAN	F5 ALIGN SCAN	F6	F7	F8	F9	F10 EXIT

Figure 9. Service/Alignment Menu

B. Align Radio Parameters

If you selected the ALIGN RADIO function in the SERVICE screen, the system will display the screens shown in Figures 10a and 10b. These screens will allow you to adjust 14 parameters (including Secure Deviation Offset for a SECURENET radio). Each of these parameters are explained below, followed by the procedure needed to set these parameters correctly for the radio being aligned. Note that on certain alignment procedures, the last step states "Reprogram radio." This means that *after* all alignment is completely finished, you must reprogram the radio. You do not have to reprogram the radio after each parameter is aligned.

MOTOROLA Radio Service Software SABER Model Ver. R07.01.00 Main.Align.Radio	Use UP / DWN Arrows to Change Value. PGUP / PGDN to Change Rapidly.																														
ALIGN RADIO PARAMETERS																															
<table style="width: 100%; border: none;"> <tr> <td style="width: 60%;">Oscillator WARP</td> <td style="width: 10%; text-align: center;">00</td> <td style="width: 30%;"></td> </tr> <tr> <td>Low POWER level</td> <td style="text-align: center;">00</td> <td>Power Bias is HIGH</td> </tr> <tr> <td>Medium POWER level</td> <td style="text-align: center;">00</td> <td>Power Bias is HIGH</td> </tr> <tr> <td>High POWER level</td> <td style="text-align: center;">00</td> <td>Power Bias is HIGH</td> </tr> <tr> <td>Special POWER level</td> <td style="text-align: center;">00</td> <td>Power Bias is HIGH</td> </tr> <tr> <td>Low Battery Threshold</td> <td style="text-align: center;">00</td> <td></td> </tr> <tr> <td>Battery Save Squelch</td> <td style="text-align: center;">00</td> <td></td> </tr> <tr> <td>Secure Deviation Offset</td> <td style="text-align: center;">00</td> <td></td> </tr> </table>		Oscillator WARP	00		Low POWER level	00	Power Bias is HIGH	Medium POWER level	00	Power Bias is HIGH	High POWER level	00	Power Bias is HIGH	Special POWER level	00	Power Bias is HIGH	Low Battery Threshold	00		Battery Save Squelch	00		Secure Deviation Offset	00							
Oscillator WARP	00																														
Low POWER level	00	Power Bias is HIGH																													
Medium POWER level	00	Power Bias is HIGH																													
High POWER level	00	Power Bias is HIGH																													
Special POWER level	00	Power Bias is HIGH																													
Low Battery Threshold	00																														
Battery Save Squelch	00																														
Secure Deviation Offset	00																														
<table style="width: 100%; border: none;"> <tr> <td style="text-align: center;">0</td> <td style="text-align: center;">10</td> <td style="text-align: center;">20</td> <td style="text-align: center;">30</td> <td style="text-align: center;">40</td> <td style="text-align: center;">50</td> <td style="text-align: center;">60</td> <td style="text-align: center;">70</td> <td style="text-align: center;">80</td> <td style="text-align: center;">90</td> <td style="text-align: center;">100%</td> </tr> <tr> <td colspan="11" style="text-align: center;"> </td> </tr> </table>		0	10	20	30	40	50	60	70	80	90	100%																			
0	10	20	30	40	50	60	70	80	90	100%																					
<table style="width: 100%; border: none;"> <tr> <td style="text-align: center;">F1</td> <td style="text-align: center;">F2</td> <td style="text-align: center;">F3</td> <td style="text-align: center;">F4</td> <td style="text-align: center;">F5</td> <td style="text-align: center;">F6</td> <td style="text-align: center;">F7</td> <td style="text-align: center;">F8</td> <td style="text-align: center;">F9</td> <td style="text-align: center;">F10</td> </tr> <tr> <td style="text-align: center;">HELP</td> <td></td> <td></td> <td style="text-align: center;">MORE</td> <td style="text-align: center;">PRINT</td> <td></td> <td style="text-align: center;">TOGGLE</td> <td></td> <td></td> <td style="text-align: center;">EXIT</td> </tr> <tr> <td></td> <td></td> <td></td> <td style="text-align: center;">ALIGNMENTSSCREEN</td> <td></td> <td></td> <td style="text-align: center;">POWER BIAS</td> <td></td> <td></td> <td></td> </tr> </table>		F1	F2	F3	F4	F5	F6	F7	F8	F9	F10	HELP			MORE	PRINT		TOGGLE			EXIT				ALIGNMENTSSCREEN			POWER BIAS			
F1	F2	F3	F4	F5	F6	F7	F8	F9	F10																						
HELP			MORE	PRINT		TOGGLE			EXIT																						
			ALIGNMENTSSCREEN			POWER BIAS																									

Figure 10a. Align Radio Menu 1

MOTOROLA Radio Service Software SABER Model Ver. R07.01.00 Main.Align.Radio	Use UP / DWN Arrows to Change Value. PGUP / PGDN to Change Rapidly.																														
ALIGN RADIO PARAMETERS																															
<table style="width: 100%; border: none;"> <tr> <td style="width: 60%;">Audio Processing</td> <td style="width: 10%; text-align: center;">FF</td> <td style="width: 30%;">(Disabled)</td> </tr> <tr> <td>Sidetone Volume</td> <td style="text-align: center;">00</td> <td></td> </tr> <tr> <td>DTMF Dial Delay</td> <td style="text-align: center;">00</td> <td></td> </tr> <tr> <td>DTMF Tone on Time</td> <td style="text-align: center;">00</td> <td></td> </tr> <tr> <td>DTMF Tone off Time</td> <td style="text-align: center;">00</td> <td></td> </tr> <tr> <td>Mic Gain</td> <td style="text-align: center;">0dB</td> <td></td> </tr> </table>		Audio Processing	FF	(Disabled)	Sidetone Volume	00		DTMF Dial Delay	00		DTMF Tone on Time	00		DTMF Tone off Time	00		Mic Gain	0dB													
Audio Processing	FF	(Disabled)																													
Sidetone Volume	00																														
DTMF Dial Delay	00																														
DTMF Tone on Time	00																														
DTMF Tone off Time	00																														
Mic Gain	0dB																														
<table style="width: 100%; border: none;"> <tr> <td style="text-align: center;">0</td> <td style="text-align: center;">10</td> <td style="text-align: center;">20</td> <td style="text-align: center;">30</td> <td style="text-align: center;">40</td> <td style="text-align: center;">50</td> <td style="text-align: center;">60</td> <td style="text-align: center;">70</td> <td style="text-align: center;">80</td> <td style="text-align: center;">90</td> <td style="text-align: center;">100%</td> </tr> <tr> <td colspan="11" style="text-align: center;"> </td> </tr> </table>		0	10	20	30	40	50	60	70	80	90	100%																			
0	10	20	30	40	50	60	70	80	90	100%																					
<table style="width: 100%; border: none;"> <tr> <td style="text-align: center;">F1</td> <td style="text-align: center;">F2</td> <td style="text-align: center;">F3</td> <td style="text-align: center;">F4</td> <td style="text-align: center;">F5</td> <td style="text-align: center;">F6</td> <td style="text-align: center;">F7</td> <td style="text-align: center;">F8</td> <td style="text-align: center;">F9</td> <td style="text-align: center;">F10</td> </tr> <tr> <td style="text-align: center;">HELP</td> <td></td> <td></td> <td style="text-align: center;">MORE</td> <td style="text-align: center;">PRINT</td> <td></td> <td style="text-align: center;">TOGGLE</td> <td></td> <td></td> <td style="text-align: center;">EXIT</td> </tr> <tr> <td></td> <td></td> <td></td> <td style="text-align: center;">ALIGNMENTSSCREEN</td> <td></td> <td></td> <td style="text-align: center;">POWER BIAS</td> <td></td> <td></td> <td></td> </tr> </table>		F1	F2	F3	F4	F5	F6	F7	F8	F9	F10	HELP			MORE	PRINT		TOGGLE			EXIT				ALIGNMENTSSCREEN			POWER BIAS			
F1	F2	F3	F4	F5	F6	F7	F8	F9	F10																						
HELP			MORE	PRINT		TOGGLE			EXIT																						
			ALIGNMENTSSCREEN			POWER BIAS																									

Figure 10b. Align Radio Menu 2

Each parameter can be adjusted one of three ways:

The UP arrow key will increase the parameter value. The DOWN arrow key will decrease the parameter value.

The PGUP key will increase the parameter with a rate increase of 10% present value. The PGDN key will decrease the rate of decrease by 10 % present value.

The UP/DOWN keys may also act as a toggle between two given parameter values or choices such as "ON/OFF" or "YES/NO."

1. Oscillator Warp

This adjustment sets the reference oscillator so that the transmit and receive frequencies are set correctly for the radio. Since the SABER radio is a synthesized radio, this one adjustment will set ALL the receive and transmit frequencies in the radio correctly, once you set oscillator warp correctly on one frequency. When aligning Oscillator Warp, you can see the change in frequency during the alignment process or in "real time." You do not have to reprogram the radio to see the immediate frequency change. To perform this adjustment, use the procedure given below.

- (a) Follow the Setup Procedure in Section VI-A, Fig. 8.
- (b) Key up the radio by pressing the push-to-talk (PTT) button on the radio or by using the PTT switch on the test set. Ensure that you have the RF connector terminated in a 50 ohm load and connected to a frequency counter so that you can measure the transmit frequency. Determine the frequency error between the desired channel frequency and the frequency measured.
- (c) De-key the radio.
- (d) Calculate the number of steps required to bring the radio on frequency using the following formulas:

For UHF radios: number of steps = (frequency error in Hz) / 180

For VHF radios: number of steps = (frequency error in Hz) / 80

NOTE: A negative frequency error indicates that the frequency will have to be increased by stepping up with the UP arrow key (or PGUP). A positive frequency error indicates that the frequency will have to be decreased by stepping down with the DOWN arrow key (or PGDN).

- (e) Select the OSCILLATOR WARP item on the screen by using the ENTER or TAB key. The selected item will be highlighted in inverse video.
- (f) Use the UP or DOWN arrow key to decrease or increase the value of the number shown by the number of steps calculated above. Note that the number shown is a hexadecimal number and the numbers will go from 00 through FF. As an example, if the original value shown is 44, pressing the UP arrow key will cause the number to scroll through the following sequence - 45, 46, 47, 48, 49, 4A, 4B, 4C, 4D, 4E, 4F, 50, 51, etc...

If you had calculated that 13 positive steps were required to bring it on frequency, you can press and release the UP arrow key 13 times. Or, you can hold the UP arrow key down and the numbers will scroll up in value and once you have reached the desired value, release the key. You may also use the PGUP key to increment by 10.

- (g) Key the radio and check the frequency. Repeat the procedure if necessary. Ensure that the measured frequency is within the specified frequency window for that radio model.

2. Power Level

Four different power levels can be adjusted in the SABER radio - the low, medium, high, and special power levels. (Each channel in the radio can have unique power level assignments made on the Radio Channel Information screen described in Section VIII-C.) Note that the standard low and high power settings for UHF are 2.0W to 5.0W respectively, and for VHF the power settings are 2.5W to 6.0W respectively. Even though these are the standard settings, you can set the power levels to any value up to the maximum setting allowed. Note that you can set both the low and high power levels to the same value if you wish, which allows both settings to have either a low power setting, a high power setting, or any power level up to the maximum level allowed.

Use the ENTER key to select the power setting you wish to adjust: LOW, MEDIUM, HIGH, or SPECIAL. Once you have selected the appropriate power level, (the selected power level setting will be highlighted in inverse video), follow the procedure given below. When aligning the Power Level, you can check the power output during the alignment process or in "real time." You do not have to reprogram the radio to see the immediate power change.

- (a) Follow the Setup Procedure in Section VI-A, Fig. 8.
- (b) Before aligning the power level, select the proper TOGGLE POWER BIAS with the F7 function key according to the table below:

Select Power Bias High:
> 2 W. for High power radios

Select Power Bias Low:
< 2 W. for High power radios

OR

> 1 W. for Low power radios < 1 W. for Low power radios

- (c) Choose a channel with a frequency as close to the center of the band as possible, or the center frequency of the radio to be aligned. Set the radio to that channel.
- (d) Connect the RF BNC connector to an RF power meter.
- (e) Key up the radio and measure the RF power.
- (f) De-key the radio and use the arrow keys to adjust the power to the desired power setting. The UP arrow key (or PGUP) will increase the power level setting value if the measured power is lower than the desired value while the DOWN arrow key (or PGDN) will decrease the power level value if the measured power is higher than the desired value.
- (g) Re-key the radio and measure the output power.
- (h) Repeat the procedure until the power level is at the desired level.
- (i) Check power output at the band edges (by going to the channel closest to the band edges) to ensure that you meet the power requirements at those frequencies. If required, return to the center frequency and adjust the power so that you meet the requirement across the band.

Once you have completed one of the power level setting adjustments, select the other power level setting and repeat the above procedure to obtain the desired power setting.

3. Low Battery Threshold

Low Battery Threshold determines at what voltage level the LED will blink to indicate that the battery voltage has fallen below the preprogrammed value in transmit mode. On the display of your radio, you will see a battery flashing symbol. When aligning Low Battery Threshold, you will not be able to test the voltage level until you reprogram the radio first. In order to align this parameter, follow the steps below:

- (a) Set up a battery block for the radio along with the Setup Procedure in Section VI-A, Fig. 8.
- (b) Use the UP/DOWN arrow keys or PGUP/PGDN to increase/decrease these values. The default value for this parameter is \$9E which corresponds to 6.5 volts.
- (c) Reprogram radio if finished with ALL alignment functions.

4. Battery Save Squelch

This adjustment is used to set the carrier squelch level at which the receiver will operate when the radio is in battery save mode. Set the value to optimize battery save performance for the particular system in which the radio will operate. When aligning Battery Save Squelch, you will not be able to test the squelch level until you reprogram the radio first. In order to align battery save squelch, follow the steps below:

- (a) Follow the Setup Procedure in Section VI-A, Fig. 8.
- (b) In order to align this parameter, you MUST be in Battery Save Squelch Mode which can be done by first going into ALIGN CHANNEL and enabling the Battery Save Enable bit. Return to ALIGN RADIO and reselect this alignment option.
- (c) The Battery Save Squelch bytes contain the squelch level to be used while in battery save mode. The default value for this byte can be determined as follows:

First find the minimum squelch among the channels defined for the radio and use this value to index the following table to determine the value of Battery Save Squelch.

<u>Minimum Squelch Level</u>	<u>Battery Save Squelch Level</u>
\$00	\$00 (minimum squelch)
\$01	\$01
\$02	\$02
\$03	\$03
\$04	\$03
\$05	\$03 --open squelch--
\$06	\$04
\$07	\$05
\$08	\$06
\$09	\$07
\$0A	\$08
\$0B	\$0A
\$0C	\$0B
\$0D	\$0C
\$0E	\$0D
\$0F	\$0E (maximum squelch)

Other values for the Battery Save Squelch level may be selected with the RSS. The squelch values can range from \$00 to \$0F where \$00 is the minimum squelch setting.

- (d) To ensure the radio is in the battery save Mode, wait until the radio unmutes at carrier and wait the proper dwell time before injecting a signal at the specific level for testing. If this time is not accounted for, then you may still be in dwell mode. Dwell mode can range from approximately 5 to 8 seconds.
- (e) Use the UP/DOWN or PGUP/PGDN arrow keys to increase/decrease these values.
- (f) Reprogram radio if finished with ALL alignment functions.

5. Audio Processing

This adjustment sets the volume level at which the audio processing filter will cut in to cause a roll-off of audio frequencies below 1kHz. The audio processing filter is a high pass filter with a high frequency corner at 1kHz. When this audio processing filter kicks in, audio that would normally be distorted at high volume levels becomes more intelligible or audible. When aligning Audio Processing, you will not be able to test the audio level until you reprogram the radio first. In order to align this parameter follow the steps below:

- (a) Follow the Setup Procedure in Section VI-A.
- (b) First determine at what level you wish to set the volume level to meet radio environment .
- (c) A nominal level to begin testing is at \$C0, where levels below \$C0 have regular audio, and levels above \$C0 enables the audio processing filter. The system default value is \$FF to disable audio processing, and \$EB is the maximum value to enable audio processing. The valid range for aligning is \$00 - \$FF (or 0 - 255).
- (d) Use the UP/DOWN or PGUP/PGDN arrow keys to increase/decrease these values.
- (e) Reprogram radio if finished with ALL alignment functions.

6. Sidetone Volume

This parameter controls the sidetone volume level. Its value ranges from \$00 to \$FF in steps of 1. To see the effect of the change, the radio must first be reprogrammed.

- (a) Follow the setup procedure in Section VI-A, Fig. 8.
- (b) Determine the sidetone volume level desired and use the UP/DOWN or PGUP/PGDN arrow keys to increase/decrease the level.
- (c) Reprogram radio if finished with ALL alignment functions.

7. DTMF Dial Delay

This parameter controls the DTMF pretime. Its value ranges from \$00 to \$FF in steps of 1. To see the effect of the change, the radio must first be reprogrammed.

- (a) Follow the setup procedure in Section VI-A, Fig. 8.
- (b) Determine the dial delay desired and use the UP/DOWN or PGUP/PGDN arrow keys to increase/decrease this delay.
- (c) Reprogram radio if finished with ALL alignment functions.

8. DTMF Tone On Time

This parameter sets the DTMF tone duration. Its value ranges from \$01 to \$FF (1 to 255) in 5 millisecond units (5 ms to 1.275 seconds). The default value is \$0C, which is 60 ms. When aligning DTMF Tone On Time, you will not be able to test the ON time until you reprogram the radio first.

- (a) Follow the Setup Procedure in Section VI-A, Fig. 8.
- (b) Determine what tone duration you wish to have and use the UP/DOWN or PGUP/PGDN arrow keys to increase/decrease these values.
- (c) Reprogram radio if finished with ALL alignment functions.

9. DTMF Tone Off Time

This parameter defines the time between DTMF tones. The value for this parameter ranges from \$01 to \$FF (1 to 255) in 5 ms units (5 ms to 1.275 seconds). The default value is \$1C, which is 140 ms. When aligning DTMF Tone Off Time, you will not be able to test the OFF time until you reprogram the radio first.

- (a) Follow the Setup Procedure in Section VI-A, Fig. 8.
- (b) Determine what tone duration you wish to have and use the UP/DOWN or PGUP/PGDN arrow keys to increase/decrease these values.
- (c) Reprogram radio if finished with ALL alignment functions.

10. Secure Deviation Offset

This parameter defines a deviation adjustment that is applied during coded transmissions. You can only align this value if you have a radio that has a voice privacy module installed. If you selected option H432 in "Radio Feature Options," then this adjustment is not necessary. The default value is 0. When aligning Secure Deviation Offset, you can see the change in deviation during the alignment process or in "real time." You do not have to reprogram the radio to see the immediate deviation change. To perform this adjustment, follow the procedure given below.

- (a) Follow the Setup Procedure in Section VI-A, Fig. 8.

- (b) Before proceeding, you must have previously aligned the VCO and Reference Modulation. If you have not done this yet, press ESC to return to the SERVICE menu, then follow the instructions in the section "Align Channel." Upon returning to the SERVICE menu, reselect "Align Radio" and proceed.

One additional requirement is that your radio must have a "KEY" loaded for coded transmission. To check this, select a channel that is programmed (SLAVED) for coded transmission or place the clear/coded switch in the coded position and key the radio. If there is no key present, the radio will continuously emit short alert tones indicating a "key fail" condition. On SABER models with a display, the key fail message will display as long as the radio is keyed up.

NOTE

After aligning VCO, REF MOD and returning to the align radio screen, do not change channels as this will result in the old tuning information being used.

- (c) Select the Secure DEVIATION OFFSET item on the screen by using the ENTER key. The selected item will be highlighted in inverse video.
- (d) Place the clear/coded transmission switch in the coded position.
- (e) Connect the RF BNC connector to a 50 ohm load and to a service monitor (with Secure) so that you can measure deviation.
- (f) Select the Secure function on the service monitor. Increase or decrease the deviation offset value by one step using the up or down arrow key. This enables the RSS to strap this channel coded if you just left the align channel screen which straps the radio clear.
- (g) Key the radio, measure and record the Secure deviation. Label the result as DVP DEV.
- (h) De-key the radio.
- (i) The Secure deviation measured should be adjusted to be 4 KHz +/- 500.
- (j) To calculate the Secure Deviation Offset adjustment required, apply the formula below to the measured deviation:
$$\text{Steps} = \text{LOG}_{10} (\text{DVP DEV} / 4000) * 20 / .35$$
- (k) Use the DOWN or UP arrow keys to decrease or increase the value shown on the display for Secure deviation. Note that the number shown is in hexadecimal. The value of this number ranges from F0 to 1F. As an example, if the starting value is F9, repeated pressing of the UP arrow key would produce the following sequence - F9, FA, FB, FC, FD, FE, FF, 00,01, 02, 03, 04, 05, etc..
- (l) Re-key the radio, and measure the deviation again. Repeat the adjustment, until measured deviation is 4 KHz. Note that if the channel you're using has not been properly aligned beforehand, it may not be possible to correctly align the Secure Deviation Offset.
- (m) If the Secure Deviation Offset adjustment does not provide enough "steps" for you to align, then the channel is not aligned properly, or the radio needs service.
- (n) Reprogram the radio.

11. MICROPHONE GAIN

This parameter is used when sending out the voice signal. There are 4 different values from which you can choose : -3 dB, 0 dB (default), +3 dB, and +6 dB. The radio has to be reprogrammed to see the effect of the change. This will only work on radios with the H852, 6D master option enabled or the H549, 8D master option enabled.

- (a) Follow the setup procedure in Section VI-A, Fig. 8.
- (b) Determine the microphone gain you wish to have and use the UP/DOWN or PGUP/PGDN arrow keys to increase/decrease these values.
- (c) Reprogram radio if finished with ALL alignment functions.

Once you have completed the radio level alignment adjustments, press the F10 key to return to the SERVICE menu.

C. Align Channel Parameters

In order to align the channel level parameters, squelch, VCO Modulation, Reference Modulation, and Battery Save Enable, select the ALIGN CHANNEL PARAMETERS item in the ALIGN menu. These parameters are called channel level parameters because they have to be adjusted on every channel as opposed to the radio level parameters which apply to all the channels in the radio. Once the ALIGN CHANNEL menu has been selected, the system will display the screen shown in Figure 11. At the bottom of the screen the current zone/channel combination being aligned will be displayed. Merely select the next zone/channel on the radio to be aligned and the screen will update the display.

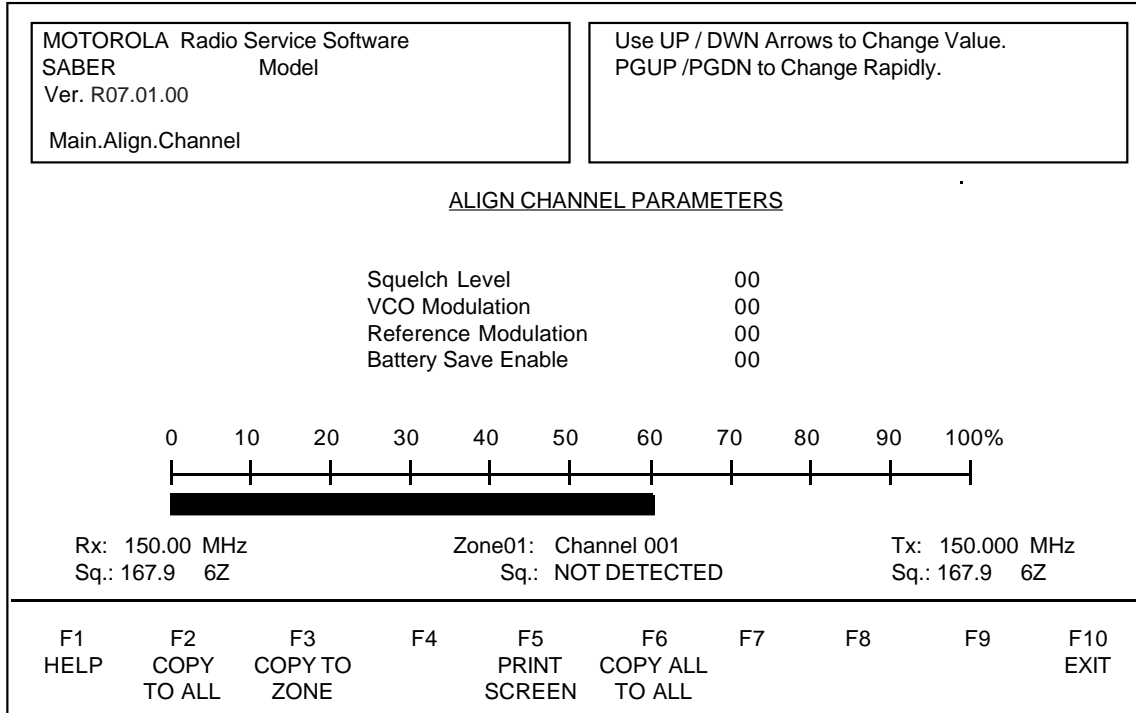

Figure 11. Align Channel Menu

Note that on certain alignment procedures, the last step states "Reprogram radio," this means AFTER all alignment is completely finished, you must reprogram the radio. You do not have to reprogram the radio after each parameter is aligned.

Function Key Descriptions:

- F2 Copy to all** - This function key will copy a particular alignment parameter value to all the channels. For example, If VCO for the current channel is \$1F, pressing F2 will set VCO to \$1F in all channels.
- F3 Copy to zone** - This function key will copy the particular alignment parameter value to all the channels in the current zone.

F5 **Print screen** - This function key will print out everything shown on the screen.

F6 **Copy all To all** - This function key will copy EVERY alignment parameter in the current channel to all the channels in the radio regardless of zone.

The lower portion of the screen contains some additional information that will be helpful in the alignment process. The SQ field lets the user know whether or not squelch has been detected by the radio's receiver. This allows you to set threshold squelch on those channels which are PL protected. This means that you will not need to have any carrier squelch channels programmed into the radio in order to set the squelch.

1. Squelch

When aligning squelch on PL/DPL channels, use the squelch (SQ) field in the lower portion of the screen to determine when the radio squelches. On carrier squelch (CSQ) channels, you can also listen to the reference speaker in the portable products test set. When aligning Squelch, you can hear the change in the squelch level during the alignment process or in "real time." You do not have to reprogram the radio to hear the immediate change.

- (a) Follow the Setup Procedure in Section VI-A, Fig. 8.
- (b) Select any channel on the radio.
- (c) Select the SQUELCH function in the ALIGN CHANNEL screen.
- (d) With no RF signal applied to the radio, set the squelch value to \$0 by using the DOWN arrow key. You should hear noise through the speaker in the test set (CSQ) and SQ should be OFF (CSQ & PL/DPL). Set the switch on the test set at the load position instead of the speaker position and the volume on the radio set at rated audio.
- (e) Connect the RF BNC connector to the service monitor so that you can measure SINAD.
- (f) Increase the RF, on the correct carrier frequency, until 8dB to 12dB SINAD is measured.
- (g) Increment the squelch value by using the UP arrow key until the radio squelches (no noise present or SQ is ON). The valid range for squelch is from \$0 to \$0F, with a default value of \$09.
- (h) You can now set the same squelch value to all the channels in the radio by pressing the F2 key. Pressing the F2 key will cause the current squelch value to be copied over to all the other channels in the radio. If you want to make the squelch value different on any other channel, you will have to go to that channel and set the squelch by following the procedure given above.

2. VCO and Reference Modulation Alignment

When adjusting deviation, two separate adjustments are required - one for VCO modulation and the other for REFERENCE modulation. When aligning VCO and Reference Modulation, you can measure the deviation during the alignment process or in "real time." You do not have to reprogram the radio to measure the change. However, you will have to reprogram the radio to make these changes permanent. Do NOT turn off the radio while aligning this parameter. The procedure given below will go through both of these adjustments.

- (a) Follow the Setup Procedure in Section VI-A, Fig. 8.
- (b) Connect the RF BNC connector to a 50 ohm load and to a service monitor so that you can measure deviation.
- (c) Select the VCO Modulation function on the ALIGN CHANNEL menu using the ENTER key.
- (d) Using the UP arrow key, set the VCO Modulation value to \$1F.
- (e) Select the REFERENCE Modulation function on the ALIGN CHANNEL menu by using the ENTER key.
- (f) Using the UP arrow key, set the REFERENCE Modulation value to \$0F.
- (g) Now select the VCO Modulation function on the ALIGN CHANNEL menu.
- (h) Apply a 1 kHz, 25 mVrms tone to the external microphone port on the test set. Measure this level at the AC/DC metering jacks on the Portable Test Set. Measure deviation by keying up the radio.
- (i) De-key the radio and adjust the VCO modulation value (decrease the value if the measured deviation is higher than the required value) by using the DOWN key to decrement value. The valid range for this parameter is from \$00 to \$1F with a default value of \$1C.
- (j) Re-key the radio and measure the deviation. Repeat the procedure (this step and the step above this) until the required deviation is reached.
- (k) Apply a 0.355 Vrms, 1 kHz tone to the auxiliary transmit port on the radio (the female BNC connector). The signal level should be measured with the audio generator connected to the radio. To do this you will have to use a T-connector so that you can simultaneously apply the signal to the radio as well as applying it to the AC meter.
- (l) Select the REFERENCE Modulation function on the ALIGN CHANNEL menu by using the ENTER key. By selecting this function, the radio service software enables the auxiliary port of the radio after being keyed.

NOTE

Reference modulation cannot be aligned on channels that have MDC signalling enabled. On completion of the MDC signalling, the radio disables the auxiliary port.

- (m) Key the radio, and measure this deviation and note it as DEV 1. De-key the radio.
- (n) Remove the 1 kHz tone and apply a 0.355Vrms, 20 Hz tone to the auxiliary port.
- (o) Key the radio, and measure this deviation and note it as DEV 2. De-key the radio.

- (p) Adjust the REFERENCE Modulation value by using the DOWN arrow key. Repeat the step above until DEV 2 = DEV 1.

3. Battery Save Enable

Battery Save Enable allows you to enable the Battery Save Squelch option in ALIGN RADIO for a particular channel. The battery save will be turned off while scan is activated, and when scan is deactivated this function becomes enabled on that channel and resume its programmed state. When aligning Battery Save Enable, you can notice the change during the alignment process or in "real time." You do not have to reprogram the radio to see the immediate change. In order to enable this parameter, follow the steps below:

- (a) Follow the Setup Procedure in Section VI-A, Fig. 8.
- (b) Use the UP/DOWN arrow keys to toggle this option.
- (c) Invoke a new channel to check this change, or key up and de-key the radio.

D. Align Scan Controls

If you had selected the ALIGN SCAN CONTROLS function in the SERVICE screen, the system will display the screen shown in Figure 12. These screens will allow you to align Scan monitor hold time, Scan receive response time, Scan transmit response time, and Scan priority squelch. Each of these parameters are explained below, followed by the procedure needed to set these parameters correctly for the radio being aligned. Note that on certain alignment procedures, the last step states "Reprogram radio," this means AFTER all aligning is completely finished you must reprogram the radio. You do not have to reprogram the radio after each parameter is aligned.

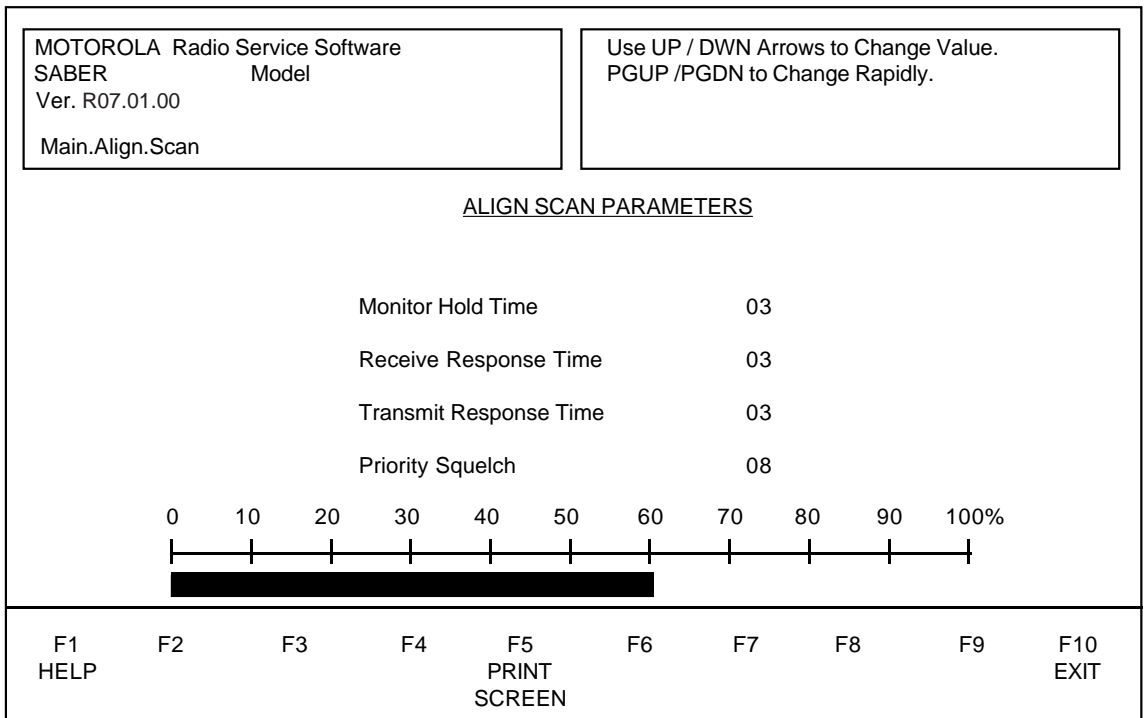

Figure 12. Align Scan Menu

The only function key here that needs to be explained is PRINT SCREEN (F5) which will print out a hard copy of the screen shown.

Each parameter can be adjusted one of three ways:

The UP arrow key will increase the parameter value. The DOWN arrow key will decrease the parameter value.

The PGUP key will increase the parameter with a rate increase of 10 times its present value. The PGDN key will decrease the rate of decrease by 10 times its present value.

In the following sections below, each alignment parameter with its proper aligning procedures are explained.

1. Scan Monitor Hold Time

Monitor Hold Time determines how long the radio will remain on the monitored channel once the monitor button is released. During monitor hold time, squelch and PL are not defeated unless permanent monitor has been engaged. After Monitor Hold Time expires, permanent monitor is released and normal channel scan resumes. To align this scan parameter, follow the steps below:

- (a) Set up according to Section VI-A, Fig. 8 and select the SCAN MONITOR HOLD TIME option in the Align Scan Menu.
- (b) Increment or decrement the time parameter accordingly using the UP (or PGUP) or the DOWN (or PGDN) arrow keys.
- (c) Valid time range is from \$01 to \$3C (1 to 60 seconds) with a default value of \$03 or 3 seconds.
- (d) Reprogram radio if finished with ALL alignment functions.

2. Scan Receive Response Time

After a message is received while scanning, a programmable time interval (0 to 60 seconds in 1 second steps) will be in effect called the Receive Response Time. Within this time, the radio will not resume scan but will continue to monitor the mode of the last received message due to the likelihood of receiving (or wanting to transmit) a response. Transmission during this interval will occur on the mode being monitored rather than on the Preassigned Transmit Mode. Priority modes will continue to be sampled during this time but other modes will not be scanned. To align this scan parameter follow the steps below:

- (a) Set up according to Section VI-A, Fig. 8 and select the SCAN RECEIVE RESPONSE TIME option in the Align Scan Menu.
- (b) Increment or decrement the time parameter accordingly using the UP (or PGUP) or the DOWN (or PGDN) arrow keys.
- (c) Valid time range is from \$01 to \$3C (1 to 60 seconds) with a default value of \$03 or 3 seconds.
- (d) Reprogram radio if finished with ALL alignment functions.

3. Scan Transmit Response Time

After transmitting a message while scanning, a programmable time interval (0 to 60 seconds in 1 second steps) will be in effect called the Transmit Response Time. Within this time, the radio will not resume scan (except for priority samples) but will continue to monitor the last transmitted mode due to the likelihood of receiving a response. Functionally, there are 2 differences between the Transmit and Receive Response Times:

- (a) Transmitting during the TRT will not change the floating priority.
- (b) The timer values can be different.

To align this scan parameter follow the steps below:

- (1) Set up according to Section VI-A, Fig. 8 and select the SCAN TRANSMIT RESPONSE TIME option in the Align Scan Menu.
- (2) Increment or decrement the time parameter accordingly using the UP (or PGUP) or the DOWN (or PGDN) arrow keys.
- (3) Valid time range is from \$01 to \$3C (1 to 60 seconds) with a default value of \$03 or 3 seconds.
- (4) Reprogram radio if finished with ALL alignment functions.

4. Scan Priority Squelch

This value corresponds roughly to the squelch values which are 'aligned' using the align channel window of the Radio Service Software. The priority squelch level is used when checking priority channels while the radio is unmuted on an active channel. Sensitivity to priority channels in the unmuted state is affected by this value. Lower values will make the radio more sensitive, but too low a value may cause falsing. The default value is 8 and should only be changed if difficulties with priority sensitivity are encountered. To align this scan parameter, follow the steps below:

- (a) Set up according to Section VI-A. and select the SCAN PRIORITY SQUELCH option in the Align Scan Menu.
- (b) Increment or decrement the time parameter accordingly using the UP (or PGUP) or the DOWN (or PGDN) arrow keys.
- (c) Valid range is from \$0 to \$0F (0 to 15) with a default value of \$08 (or 8).
- (d) Reprogram radio if finished with ALL alignment functions.

VII. GET/SAVE/PROGRAM CODEPLUG DATA FROM/TO DISK/CODEPLUG

This chapter deals with all reading and writing to the radio, and loading and saving to disk. After you have selected the Get/Save/Program Codeplug data From/To Disk/Codeplug, or the F3 function key from the MAIN menu, the system will bring up the screen shown in Figure 13.

MOTOROLA Radio Service Software SABER Model: Ver. R07.01.00 Main.Get/Save/Prog.	Select Function Key F1 - F10										
<u>READ / PROGRAM (LOAD / SAVE) MENU</u>											
F1 - Help F2 - GET Radio Personality from Disk F3 - SAVE Radio Personality to Disk F4 - Delete Radio Personality from Disk F5 F6 F7 - Read Radio Personality from Radio F8 - Program Radio Personality to Radio F9 F10 - EXIT											
<table style="width: 100%; border: none;"> <tr> <td style="text-align: center;">F1 HELP</td> <td style="text-align: center;">F2 GET A FILE</td> <td style="text-align: center;">F3 SAVE A FILE</td> <td style="text-align: center;">F4 DELETE FILE</td> <td style="text-align: center;">F5</td> <td style="text-align: center;">F6 LOAD SAVE</td> <td style="text-align: center;">F7 READ RADIO</td> <td style="text-align: center;">F8 PROG RADIO</td> <td style="text-align: center;">F9</td> <td style="text-align: center;">F10 EXIT</td> </tr> </table>		F1 HELP	F2 GET A FILE	F3 SAVE A FILE	F4 DELETE FILE	F5	F6 LOAD SAVE	F7 READ RADIO	F8 PROG RADIO	F9	F10 EXIT
F1 HELP	F2 GET A FILE	F3 SAVE A FILE	F4 DELETE FILE	F5	F6 LOAD SAVE	F7 READ RADIO	F8 PROG RADIO	F9	F10 EXIT		

Figure 13. Get/Save/Program Menu

A. The READ function

The READ function will read the radio codeplug data from the radio and generate an RSS PC file. In order to read the codeplug, you need to connect the radio to the system. To read the radio, follow the setup procedure shown in Figure 4.

- Make sure the radio is not in scan mode.
- Regardless of the type of radio model being read back (whether a SABER I, II, or III), the programmer will always read the contents of the CORE processor first. The system will display the software version level of the CORE processor being read, for example: CORE 5d , or 6d, etc...
- After reading the CORE, the system will read the COPE processor followed by the contents of the external EEPROM. This process will only occur on SABER II and III models.
- After the contents of the radio have been read back, the system will convert this data into the radio personality file. As the system is building the RPF, several messages will appear on the screen showing the process of the "build." Shown below in Figure 14 is a sample screen of READ radio.

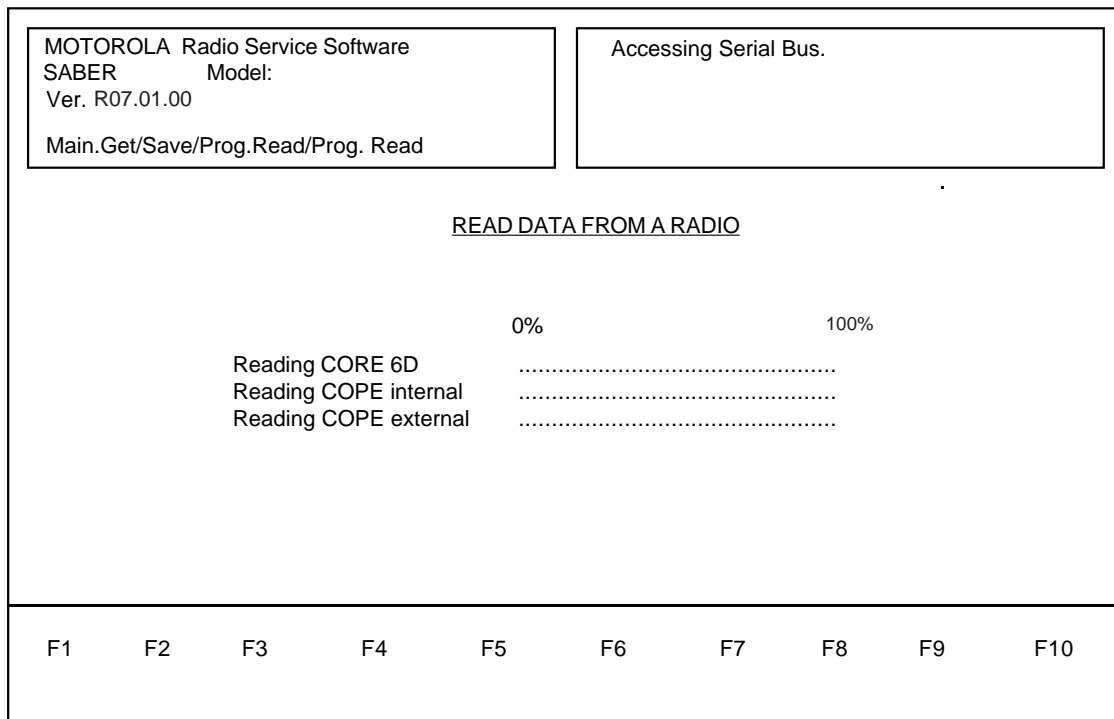

Figure 14. Read Radio Display

Note: Before reading the radio, a message may appear instructing you to press the three top keys down on the keypad (for a SABER II and III) simultaneously and turn the radio off and back on to get an ERR X YZ message on the display. Don't worry about the message unless the READ radio function does not execute. If the error message does not disappear or the READ function locks up, refer to Appendix-1, "ERROR MESSAGES."

B. The WRITE function

The WRITE function is used to program the radio, using the current radio personality data. The radio personality data may have come from disk, been read from the radio, or been created using the RSS.

Before programming can begin, the radio must first be connected through a radio interface box (RIB) to the IBM PC, and turned on. Refer to Figure 4 and Section III-C for interconnection information.

The write-to-radio process consists of two parts. In the first part, the radio personality file (RPF) is converted into codeplug(s) for the radio. During this phase, several process/status messages are displayed in the message window. These messages are of no interest unless an error is encountered during the conversion process.

In the second part of the write process, the codeplug(s) generated by the conversion process are transferred to the radio. In the case of a SABER I radio, only one codeplug is generated and written to the radio; in all other radio models, three codeplugs are generated.

Before conversion and programming begins, the RSS will prompt you to make sure that the current radio personality matches the radio to be programmed. This is normally accomplished by comparing the model number displayed by the RSS with the model number on the radio. Make sure the radio is not in scan mode before proceeding.

The RSS will also prompt you to select the source for radio alignment data. The radio alignment data may come from the RPF (F2), or the radio about to be programmed (F6). Using SHIFT - F6 the RSS will also extract the unit ID from the radio. For additional information on this subject, see the "Extraction" section on the following page.

For some radio models, the RSS will request that the radio be placed in the "programming" mode. To accomplish this:

1. Turn the radio off.
2. Press the **MENU**, **SELECT**, and **ENTER** keys simultaneously and hold them down.
3. Turn the radio on and release the three keys.
4. Check that the radio now displays "**ERR X YZ**" ("**X YZ**" will normally be "**1 00**")

For other models, the radio will be automatically placed in the "programming" mode by the RSS. In this case, the display will change to "**ERR X YZ**," and the battery annunciator will blink. This is normal operation, and does not indicate that the battery is low.

During the radio programming process, the RSS will display information about the component being programmed, and a graphic indicator of the percent of programming completed. Figure 15 shows a typical screen for programming a radio with display (SABER II or III). In Figure 15, the "**CORE**" is the transceiver microprocessor and the "**COPE**" is the display microprocessor. In SABER I radios there is no display processor, so the messages for programming the COPE will not appear.

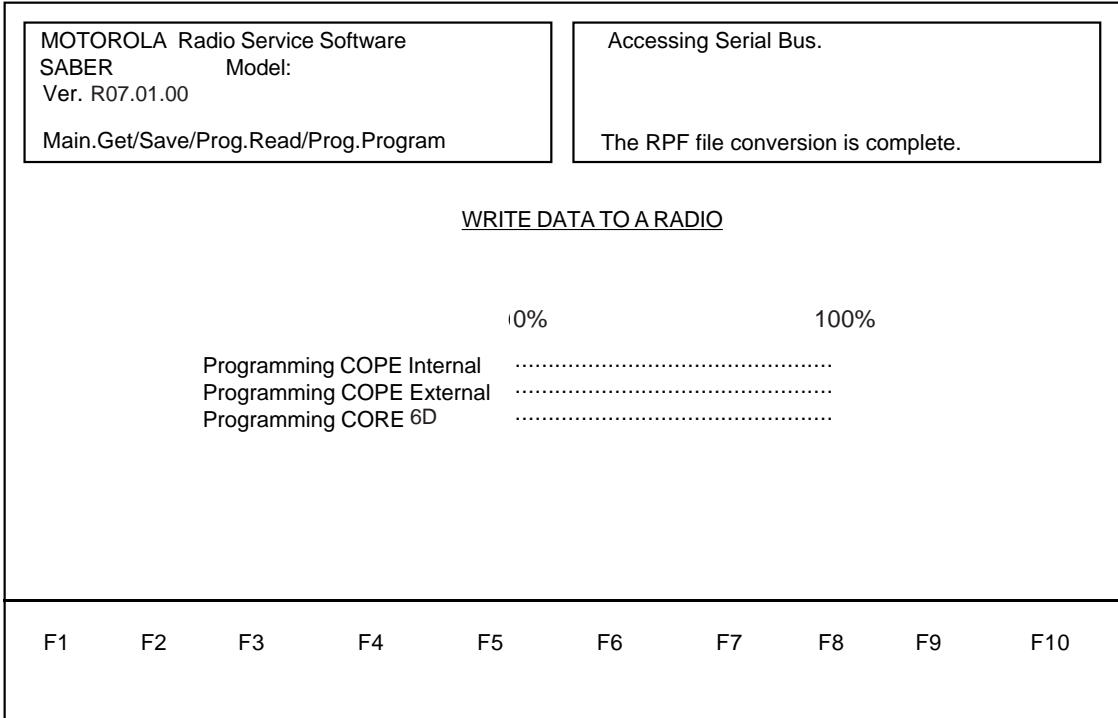

Figure 15. Write Data to Radio

When programming is complete, the RSS will revert to the "READ/PROGRAM" menu, the radio will automatically reset, and the radio display will clear. If the display still shows an "ERR X YZ" message after programming is complete, try reprogramming the radio. If the error condition persists, contact your Motorola service representative, or see Appendix-1 for a description of the error code.

Extraction:

The extraction feature enables you to easily change personalities in a radio without having to realign the radio. During the extraction process, the RSS reads all the alignment data from the radio to be programmed. This alignment data is then applied to the current radio personality, which is then converted to codeplug(s) and written to the radio in the normal way.

In order to better understand the extraction process, an explanation of the normal alignment process is necessary. First, assume that you have just created a new radio personality. The RSS, not knowing what radio the personality is destined to occupy, inserts "default" alignment values into the personality. These default values are necessary to ensure that a radio will function when programmed with the personality. Next, assume that you must put this personality into a radio that has never been aligned. You will write the personality to the radio and, when prompted, select "F2 - Use Programmer Tuning Values." This is necessary because the radio has never been aligned, and there are no existing alignment values to extract from the radio.

Next, you will align the radio using the functions provided in the "SERVICE/ALIGNMENT" menus. While you are aligning the radio, the alignment values are stored in the RPF. Finally, when you have finished the alignment, you will again write to the radio. When prompted to select F2 or F6, you will again select F2. Remember, the results of your alignment were stored in the RPF, so it no longer contains the default values placed there during personality creation, but instead contains the results of the alignment.

Now, assume that you want to put the same personality into another radio. This time, however, the radio to be programmed is already properly aligned; it just has a different personality. When prompted to select F2 or F6, you will select "F6 - Extract Alignment Value From Radio." If you had selected F2 instead, the radio would have been programmed with the alignment values of the previous radio and you would have had to align it again. Selecting F6 instructs the RSS to "extract" (read) the alignment values from the radio to be programmed, and put those values into the RPF. The "new" personality has been aligned to fit the second radio, and the resulting personality is converted to codeplug(s) and written to the radio.

The above example is only one instance where extraction is useful. There are several other cases where extraction is appropriate, and also several cases where extraction is not appropriate. To simplify the decision-making process, a flowchart (Figure 16) has been provided. To use the chart, start at its upper left corner, answer the question, and follow the line that matches your answer to the next question or action.

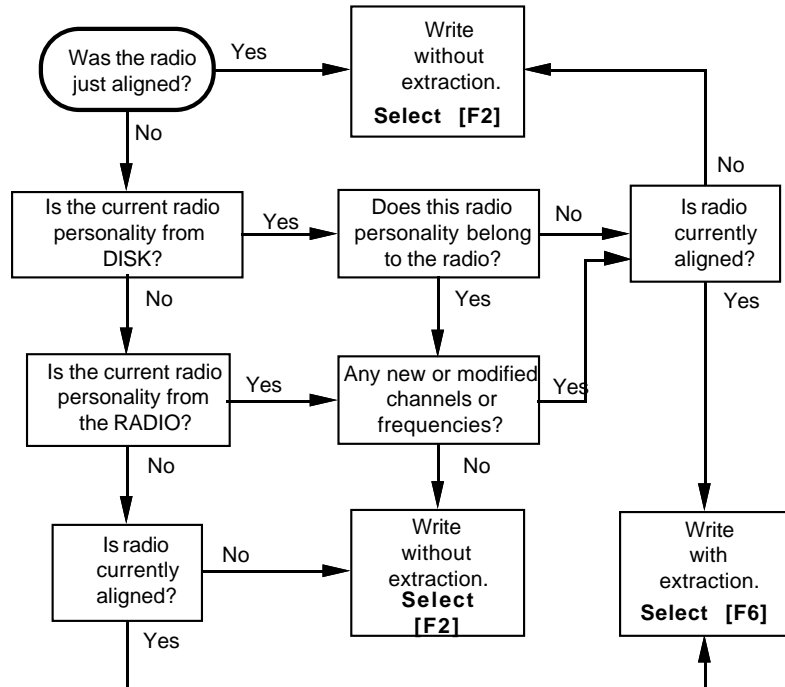

Figure 16. Extraction of Radio Alignment Data

If you use extraction (or even if you don't), it is good practice to bench-check the radio after programming. It only takes a few minutes, and it assures the radio user of the highest possible performance.

Extraction is only accurate and valid provided that frequencies in the RPF lie within the range of frequencies present in the radio. If a frequency in the RPF is higher (or lower) than the highest (lowest) frequency currently in the radio, that new frequency will get the same alignment values as the highest (lowest) frequency in the radio. For example, if you were to use extraction on a radio that was programmed with only one frequency, then after extraction, every frequency in the radio would have the same alignment values as the original frequency in the radio.

C. The LOAD/SAVE/DELETE functions

The LOAD/SAVE functions are used to transfer codeplug data from an archive file into your computer's memory in order for you to Modify, View, or Print it. The DELETE function allows you to remove any codeplug data from the computer's memory. (Refer to Figure 13.)

Function Key Descriptions:

- F2 Load Radio Personality from Disk** - The LOAD function is used to retrieve an archived file from a diskette or hard disk to the computer. Once retrieved, the file may be modified via the CHANGE/CREATE/VIEW functions, or programmed into a radio just as codeplug information read from the radio via the READ/WRITE to radio function. A menu screen will show up listing files from which you may select.
- F3 Save Radio Personality from Disk** - The SAVE function is used to create (or update) an archive copy of the codeplug information onto a diskette or hard disk. An archive copy of every radio installed or serviced is STRONGLY recommended in order to be able to quickly restore customer information in case of a codeplug failure. A menu screen will show up listing files; after saving a file, the new file name will be listed as well.
- F4 Delete Radio Personality from Disk** - The REMOVE function will delete an archive file from diskette or hard disk. A menu screen will show up listing file names; accessing this function will remove the file you choose from this list.

For all three functions LOAD, SAVE, and DELETE, a screen similar to Figure 17 of SAVE, will come up. Follow the steps listed below to implement any of these functions:

1. Select either function keys F2, F3, or F4.
2. Using the UP/DOWN arrow keys, scroll through the list of file names until you find the one you wish to either LOAD, SAVE, or DELETE.
3. Press the appropriate function key to execute the command.

MOTOROLA Radio Service Software SABER Model Ver. R07.01.00 Main.Get/Save/Prog.Load/Save	Use UP / DWN arrow keys to select.								
<u>Save Radio Personality to PC Database</u> NO ELEMENTS Archive Path: C:\RSS\SABER\DATA File Name: _____									
F1 HELP	F2 SAVE FILE	F3	F4	F5	F6	F7	F8	F9	F10 EXIT

Figure 17. Save RPF Display

VIII. CHANGE/CREATE/VIEW RADIO PERSONALITY

This chapter will take you through the screen sequences necessary to change, create, or view a radio personality file. The SABER radio, with its numerous codeplug parameters and options, offers tremendous flexibility to customize the radio configuration to almost any customer requirement. After selecting this function (F4), the screen in Figure 18 will be shown. In general, this function can create a radio personality by selecting a model number and radio frequency range, or modify an existing RPF. The following sections provides a detailed explanation of each function key.

MOTOROLA Radio Service Software SABER Model: Ver.R07.01.00 Main.Create/Modify.	Select Function Key F1 - F10																				
<u>CREATE /MODIFY /VIEW CODEPLUG</u>																					
F1 - Help for Create and Modify F2 - View Radio Information F3 - CREATE Radio Personality File F4 - Radio Feature Options F5 - Channel Information F6 - Auto Dial / Access and Hangup Codes F7 - F8 - Format Scan Lists F9 - Format Selectable PL F10 - EXIT																					
<table style="width: 100%; border: none;"> <tr> <td style="text-align: center;">F1</td> <td style="text-align: center;">F2</td> <td style="text-align: center;">F3</td> <td style="text-align: center;">F4</td> <td style="text-align: center;">F5</td> <td style="text-align: center;">F6</td> <td style="text-align: center;">F7</td> <td style="text-align: center;">F8</td> <td style="text-align: center;">F9</td> <td style="text-align: center;">F10</td> </tr> <tr> <td style="text-align: center;">HELP</td> <td style="text-align: center;">VIEW RADIOINFO</td> <td style="text-align: center;">CREATE RPF</td> <td style="text-align: center;">RADIO OPT</td> <td style="text-align: center;">CHAN INFO</td> <td style="text-align: center;">AUTO ACC/HNG</td> <td></td> <td style="text-align: center;">SCAN LIST</td> <td style="text-align: center;">SELECT PL</td> <td style="text-align: center;">EXIT</td> </tr> </table>		F1	F2	F3	F4	F5	F6	F7	F8	F9	F10	HELP	VIEW RADIOINFO	CREATE RPF	RADIO OPT	CHAN INFO	AUTO ACC/HNG		SCAN LIST	SELECT PL	EXIT
F1	F2	F3	F4	F5	F6	F7	F8	F9	F10												
HELP	VIEW RADIOINFO	CREATE RPF	RADIO OPT	CHAN INFO	AUTO ACC/HNG		SCAN LIST	SELECT PL	EXIT												

Figure 18. Change/Create/View Codeplug Menu

Warning: The Change/Create/View does NOT actually modify the radio codeplug data but instead it modifies a copy of the data retrieved from the codeplug (or archive file) via the Read/Write Radio (F3) or the Load/Save Disk (F6) functions.

After all Change/Create/View modifications are completed, you MUST return to the Read/Write Radio (F3) or the Load/Save Disk (F6) functions in the MAIN menu and save them to a new archive file. Otherwise, the modifications will be lost when you turn off your computer, exit the program, or load in another codeplug.

F2: VIEW Radio Personality

By selecting the VIEW function, the program brings up the screen shown below. This screen displays important information about the Radio Personality currently loaded in the RSS.

MOTOROLA Radio Service Software SABER Model: H44QXJ7139CN Ver. R07.01.00 Main.Create/Modify.View.									
<u>VIEW RADIO INFORMATION</u>									
Model Category:	SABER II (Secure)	Power Level:	High (6 Watts)						
Model Number:	H44QXJ7139CN	Number Zones:	10/10						
CORE Version:	6D	Number Channels:	120/120						
COPE Version:	5C	Number PLs:	4/32						
DVP Version:	0	CORE Patch ID:	00						
Frequency Range:	440 MHz to 470 MHz	COPE Patch ID:	05						
F1 HELP	F2	F3	F4	F5 PRINT	F6	F7	F8	F9	F10 EXIT

Figure 19. VIEW Radio Personality Menu

The field descriptions are given as:

Model Category: the type of radio and whether it is secure or clear.

Model Number: current model number.

CORE Version: CORE version found in the radio.

COPE Version: COPE version found in the radio.

DVP Version: secure module installed, if any.

Frequency Range: current operating frequency range of the radio.

Power Level: indicates High or Low power transmitter.

Number Zones: gives the current/total possible number of zones.

Number Channels: gives the current/total possible number of channels.

Number PL's: gives the current/total possible number of PL's.

NOTE: If this is an SP RSS package, the total possible numbers of PL's may actually be less than indicated.

CORE Patch ID: gives the current CORE patch id loaded in the radio.

COPE Patch ID: gives the current COPE patch id loaded in the radio.

A. F3: CREATE Radio Personality File

By selecting the CREATE function, the program will automatically bring up the first screen of the create process which is the CREATE RPF Screen. If, however a file currently exists in the work space, the system will ask you if you want to discard the data that currently exists. If you type a 'y' for yes, the CREATE RPF screen will be brought up and if you type 'n' for no, the CREATE process will abort and the MAIN menu will be redisplayed. To create a radio personality file, you must choose a model category, model number, and frequency range. The parameters on the right will change according to the selection made on the three user selections. Figure 20 displays an example of the CREATE RPF screen:

MOTOROLA Radio Service Software SABER Model: Ver. R07.01.00 Main.Create/Modify.Create	Use UP and DOWN arrow keys to Select								
CREATE RPF									
Model Category: Secure	High								
Model Number: H42QXK7139CN H99SAO58H	Mid Band								
Frequency Range: 74000000 to 88000000	Portable								
	Full Keypad Display								
	Scan Capable								
F1 HELP	F2	F3	F4	F5 PRINT	F6	F7	F8	F9	F10 EXIT

Figure 20. CREATE RPF Menu

Toggled options the USER can select:

- Model Category = Clear or Secure
- Model Number = ---SA----- (Clear) or ---QX----- (Secure)
- Frequency Range = # to # (Dependent on Radio Feature Options)

The **Model Category** field determines the model list for the Model Number field. If CLEAR is selected, then only clear models will be available in the model number field. The same holds true for the SECURE model category but only secure models will be available in the model number field.

The **Model Number** field selects the specific model. The legend at the right of the screen will change as you scroll through the model types and display the major characteristics of each model. As with the Model Category, the selection made in this field will affect the following field for Frequency Range. Only models with CN in the last 2 character positions can be programmed into a 6D radio.

The **Frequency Range** field allows you to select a particular band within the model previously selected. Note that this field may display several different bands to choose from, but be sure to select the proper band that must match the radio you intend to program.

Toggled options that change in conjunction to the three selections above:

Power Level:	LOW/HIGH
Frequency Band:	UHF/VHF/Mid-band
Radio Type:	PORTABLE/SUBMERSIBLE
Display Type:	NO DISPLAY/FULL DISPLAY
Keypad:	NONE/3 KEYS/FULL KEYPAD
Bandwidth:	NARROW BAND/WIDE BAND (VHF only)
Scan Option:	SCAN CAPABLE/-----

Use the UP/DOWN arrow keys to select between the Clear and Secure models and then press the ENTER key to move to the next user selection. As you select the Model Number and Frequency Range, these parameters change again, and you will be able to create a radio personality file for your radio. The next step in creating your radio RPF is to exit this screen by pressing F10 and select your Radio Feature Options.

B. Radio Feature Options

Depending on the radio model that was selected (SABER I, II, or III) via the CREATE RPF screen, you will see one of three different Radio Feature Option screens. Figure 21 provides an example of a Radio Feature Options screen for a SABER II Secure radio, where screens for SABER II and III will vary according to the created RPF .

MOTOROLA Radio Service Software SABER Model: Ver. R07.01.00 Page1 of 4 Main.Create/Modify.Options	Use UP / DWN to Move Highlight to Item. Use F2 to Select / Deselect.																				
<u>OPTION SELECTION</u>																					
H251 - 60 second TOT H901 - Non-standard TOT H153 - Omit all tones H365 - Transmit inhibit on busy channel H359 - Channel busy LED H906 - Low battery LED H958 - Unit ID - MDC 600 H961 - Unit ID & Emergency - MDC 600 H963 - Unit ID w/ audible Emergency - MDC 600 H923 - Unit ID w/ emergency Revert - MDC 600 H959 - Unit ID - MDC 1200																					
<table style="width: 100%; border: none;"> <tr> <td style="text-align: center;">F1</td> <td style="text-align: center;">F2</td> <td style="text-align: center;">F3</td> <td style="text-align: center;">F4</td> <td style="text-align: center;">F5</td> <td style="text-align: center;">F6</td> <td style="text-align: center;">F7</td> <td style="text-align: center;">F8</td> <td style="text-align: center;">F9</td> <td style="text-align: center;">F10</td> </tr> <tr> <td style="text-align: center;">HELP</td> <td style="text-align: center;">SELECT DESELECT</td> <td></td> <td></td> <td style="text-align: center;">UPDATE MDC ID</td> <td style="text-align: center;">UPDATE RPT ID</td> <td style="text-align: center;">UPDATE MTI CD</td> <td></td> <td></td> <td style="text-align: center;">EXIT</td> </tr> </table>		F1	F2	F3	F4	F5	F6	F7	F8	F9	F10	HELP	SELECT DESELECT			UPDATE MDC ID	UPDATE RPT ID	UPDATE MTI CD			EXIT
F1	F2	F3	F4	F5	F6	F7	F8	F9	F10												
HELP	SELECT DESELECT			UPDATE MDC ID	UPDATE RPT ID	UPDATE MTI CD			EXIT												

Figure 21. Options Screen

The basic keyboard functions can be used on this screen, see Section VIII-F.

In order to select/deselect an option use the F2 function key which acts as a toggle key. The table below provides a list of options available for the different SABER models. See Appendix-5 for detailed descriptions on each available option.

<u>Option</u>	<u>Description</u>	<u>Radio Type</u>
H251	60 second TOT	SABER I, II, III
H901	Non-standard TOT	SABER I, II, III
H153	Omit all tones	SABER I, II, III
H365	Transmit inhibit on busy channel	SABER I, II, III
H359	Channel busy LED	SABER I, II, III
H958	Unit ID - MDC 600	SABER I, II, III
H959	Unit ID - MDC 1200	SABER I, II, III
H961	Unit ID & Emergency - MDC- 600™	SABER I, II, III
H962	Unit ID & Emergency - MDC- 1200™	SABER I, II, III
H963	Unit ID w/ audible Emergency - MDC- 600	SABER I, II, III
H967	Unit ID w/ audible Emergency - MDC -1200	SABER I, II, III
H923	Unit ID w/ emergency revert - MDC -600	SABER I, II, III
H946	Unit ID w/ emergency revert - MDC- 1200	SABER I, II, III
	No Channel Re-Revert After Emergency	SABER I, II, III
H770	Pretime Delay - 300ms	SABER I, II, III
H771	Pretime Delay - 700 ms	SABER I, II, III
H779	Non-standard pretime delay	SABER I, II, III
H619	Omit Side Tones	SABER I, II, III
H371	Zone and Channel Operation	SABER II, III
H396	Channel Only Operation	SABER II, III
H560	Talkaround	SABER IE
H256	Two Zone Operation	SABER IE
H384	Muting via Keypad	SABER II, III
H346	Zone Display Names	SABER II, III
H380	Channel Display Names	SABER II, III
H368	Autodial	SABER II, III
H669	Omit Inadvertent Lock	SABER II, III
H670	Omit memory - 2K memory option	SABER II
H397	Menu Lock	SABER III
H345	Radio Lock	SABER III
H297	Manual Telephone Interconnect	SABER III
H906	Low Battery LED	SABER II, III
H444	Delete Proper Code Detect	SABER I, II, III
H245	Delete Clear Mode Alert Tones on Transmit	SABER I, II, III
H244	Delete Clear Coded Transmit Switch	SABER I, II, III
H400	Secure Voice Slaved to a Mode	SABER I, II, III
H401	Clear Voice Slaved to a Mode	SABER I, II, III
H432	VP Capable Only	SABER I, II, III
H375	Selectable PL/DPL (Encode only)	SABER II, III
H649	Selectable PL/DPL (Encode/Decode)	SABER II, III
H344	Mode Slaved Scan	SABER II, III
	2nd Fixed Priority	SABER II, III
	Nuisance Mode Delete	SABER II, III
	Scroll Scan List	SABER II, III
	Designated Transmit Mode	SABER II, III
	Priority to Follow Channel Selector Switch	SABER II, III
	Auto Scan	SABER II, III
H273	Operator Selectable Scan	SABER III
	Mode Slaved Scan for SABER II.2	SABER II (CLEAR Only)

H852	6D Master Option Zero Audio Enable Quik- Call II H701- Individual Call H702- 4 Tone Group Call H703- Long Tone B Group Call H167- Timed Auto Reset H188 -Carrier Override Auto Reset Singletones - General (PTT/RATs) H707- 1 Tone Singletone Via PTT Button H742- Up to 2 Tone Singletone via RAT Buttons Singletone Non-Std. Pretime Singletone Time Duration Multiple Repeater Access Codes - MDC- 600 Multiple Repeater Access Codes - MDC -1200	SABER I, II, III
H549	8D Master Option Limited Patience Timer Emergency Acknowledge Retry Timer Remote Monitor MDC-1200 Call Alert Decode MDC-1200 Individual Selective Call Decode MDC-1200 Group Selective Call Decode MDC-1200 Decode Alert Tones DOS Mute Timer	SABER I, II, III

Function Key Descriptions:

- F5 Update MDC ID** - This function allows you to edit the MDC Unit ID without having to deselect and re-select all options involving the MDC Unit ID. This function is available only if an MDC ID related option is chosen.
- F6 Update Repeater ID** - This function allows you to edit the list of Selectable Repeater IDs. This function is available only if one of the Multiple Repeater Access Codes options are selected.
- F7 Update Manual Telephone Interconnect Codes** - This function allows you to edit the manual telephone interconnect codes without having to deselect and re-select the option. This function is available only if manual telephone interconnect (H297) is selected.

Screens (of pop-up windows) for entering parameters for options under H852 are shown below :

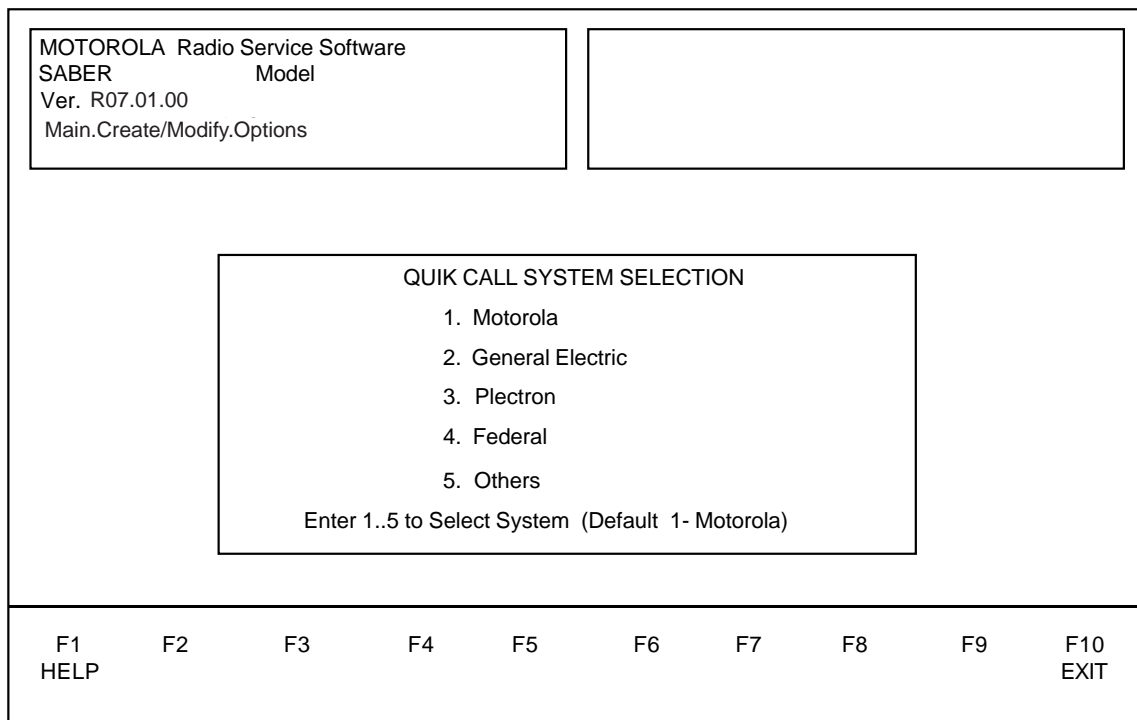

Figure 22. Quik- Call II System Selection Screen

MOTOROLA Radio Service Software SABER Model Ver. R07.01.00 Main.Create/Modify.Options	Use Up / Down Arrows to Select Entry. Use <TAB> to Switch Fields. Enter Quik Call Frequency.															
<table border="1" style="margin: auto; border-collapse: collapse;"> <tr> <th colspan="3">ENTER QUIK CALL PARAMETERS</th> </tr> <tr> <td colspan="3" style="text-align: center;">** INDIVIDUAL **</td> </tr> <tr> <td></td> <td style="text-align: center;">Frequency</td> <td style="text-align: center;">Code</td> </tr> <tr> <td>Tone A</td> <td style="text-align: center;">1357.7</td> <td style="text-align: center;">197</td> </tr> <tr> <td>Tone B</td> <td style="text-align: center;">746.6</td> <td style="text-align: center;">125</td> </tr> </table>		ENTER QUIK CALL PARAMETERS			** INDIVIDUAL **				Frequency	Code	Tone A	1357.7	197	Tone B	746.6	125
ENTER QUIK CALL PARAMETERS																
** INDIVIDUAL **																
	Frequency	Code														
Tone A	1357.7	197														
Tone B	746.6	125														
F1 HELP	F2	F3	F4	F5 PRINT SCREEN	F6	F7	F8	F9	F10 EXIT							

Figure 23. Quik- Call II H701 Parameters Screen

MOTOROLA Radio Service Software SABER Model Ver. R07.01.00 Main.Create/Modify.Options	Use Up / Down Arrows to Select Entry. Use <TAB> to Switch Fields. Enter Quik Call Frequency.																												
<table border="1" style="margin: auto; border-collapse: collapse;"> <tr> <th colspan="4">ENTER QUIK CALL PARAMETERS</th> </tr> <tr> <td colspan="2" style="text-align: center;">** INDIVIDUAL **</td> <td colspan="2" style="text-align: center;">** 2 Tone Group **</td> </tr> <tr> <td></td> <td style="text-align: center;">Frequency</td> <td style="text-align: center;">Code</td> <td></td> </tr> <tr> <td>Tone A</td> <td style="text-align: center;">1357.7</td> <td style="text-align: center;">197</td> <td style="text-align: center;">855.9</td> </tr> <tr> <td>Tone B</td> <td style="text-align: center;">746.6</td> <td style="text-align: center;">125</td> <td style="text-align: center;">601.0</td> </tr> <tr> <td></td> <td></td> <td></td> <td style="text-align: center;">158</td> </tr> <tr> <td></td> <td></td> <td></td> <td style="text-align: center;">121</td> </tr> </table>		ENTER QUIK CALL PARAMETERS				** INDIVIDUAL **		** 2 Tone Group **			Frequency	Code		Tone A	1357.7	197	855.9	Tone B	746.6	125	601.0				158				121
ENTER QUIK CALL PARAMETERS																													
** INDIVIDUAL **		** 2 Tone Group **																											
	Frequency	Code																											
Tone A	1357.7	197	855.9																										
Tone B	746.6	125	601.0																										
			158																										
			121																										
F1 HELP	F2	F3	F4	F5 PRINT SCREEN	F6	F7	F8	F9	F10 EXIT																				

Figure 24. Quik- Call II H702 Parameters Screen

MOTOROLA Radio Service Software SABER Model Ver. R07.01.00 Main.Create/Modify.Options	Use Up / Down Arrows to Select Entry. Use <TAB> to Switch Fields. Enter Quik Call Frequency.																				
<div style="border: 1px solid black; padding: 10px; margin: 0 auto; width: 80%;"> <p style="text-align: center; margin: 0;">ENTER QUIK CALL PARAMETERS</p> <table style="width: 100%; border-collapse: collapse;"> <thead> <tr> <th></th> <th colspan="2" style="text-align: center;">** INDIVIDUAL **</th> <th colspan="2" style="text-align: center;">** Long Tone B **</th> </tr> <tr> <th></th> <th style="text-align: center;">Frequency</th> <th style="text-align: center;">Code</th> <th style="text-align: center;">Frequency</th> <th style="text-align: center;">Code</th> </tr> </thead> <tbody> <tr> <td>Tone A</td> <td style="text-align: center;">1357.7</td> <td style="text-align: center;">197</td> <td></td> <td></td> </tr> <tr> <td>Tone B</td> <td style="text-align: center;">746.6</td> <td style="text-align: center;">125</td> <td style="text-align: center;">855.9</td> <td style="text-align: center;">158</td> </tr> </tbody> </table> </div>			** INDIVIDUAL **		** Long Tone B **			Frequency	Code	Frequency	Code	Tone A	1357.7	197			Tone B	746.6	125	855.9	158
	** INDIVIDUAL **		** Long Tone B **																		
	Frequency	Code	Frequency	Code																	
Tone A	1357.7	197																			
Tone B	746.6	125	855.9	158																	
F1 HELP	F2	F3	F4	F5 PRINT SCREEN	F6	F7	F8	F9	F10 EXIT												

Figure 25. Quik- Call II H703 Parameters Screen

MOTOROLA Radio Service Software SABER Model Ver. R07.01.00 Main.Create / Modify.Options	Use UP / DWN arrow keys to select row. Enter ID.								
<p style="text-align: center; margin: 0;">CREATE / MODIFY REPEATER MDC IDs</p> <p style="margin: 10px 0 0 0;">Total Entered: _____</p> <p style="margin: 10px 0 0 0;">Enter Repeater ID: _____</p> <p style="margin: 10px 0 0 400px;">Current Entry Number: _____</p>									
F1 HELP	F2	F3 INSERT ID	F4 DELETE ID	F5 PRINT SCREEN	F6	F7	F8	F9	F10 EXIT

Figure 26. Multiple Repeater Access Codes Screen

To Create or Modify any Channel Information, return to the CREATE menu using F10 and access the Channel Information menu (F5). Recall that selecting these options does NOT program the radio; return to the MAIN menu and use the Read/Write function.

C. Channel Information

Selecting the Channel Information Screen option will display a Radio Channel Definition screen shown in Figure 27. This screen contains all relevant information about all the channels in each zone (if option H371 - zone and channel Operation is selected). If you are accessing this menu option for the first time, then you will see one default channel in a default zone if H371 was selected. You can add more channels/zones using the proper function keys. Figure 27 shows a complete Radio Channel Definition with all the options. You may not have all these options enabled but for sake of discussion, we will include every entry.

MOTOROLA Radio Service Software SABER Model: Ver. R07.01.00 Main>Create/Modify.Channel	Enter frequency in 6.25 or 5 KHz steps or 'B' for RECEIVE-ONLY channel.
<u>RADIO CHANNEL DEFINITION</u>	
ZONE: ## / ____	CHANNEL: ## / ____
Tx Freq: ##### Tx PL: #####	Power Rx Freq: ##### _ Rx PL: #####
Scan List ##	
Time Out Timer - MDC ID on PTT - Emergency Revert - Channel Strapping - Enable XL -	Quik Call - Repeater Index - RAT1 Function - RAT2 Function - PTT Function -
Pre/Deemphasis - MDC Decode - Emergency PTT - DOS Muting - Tx Inhibit -	
Up/Down arrow changes channels - PgUp/PgDn changes Zones	
F1 F2 F3 F4 F5 F6 F7 F8 F9 F10 HELP ENTER ENTER WIDE PRINT MDCID COPY COPY CHANNEL ZONE VIEW TABLE FREQ PL	

Figure 27. Channel Information Screen

All keyboard commands can be found in Section II-D. with specific keyboard functions explained below:

- UP/DN arrow keys will scroll through each channel.
- PGUP/PGDN keys will scroll through each zone.
- RIGHT/LEFT arrow keys will move cursor within an entry.
- CTRL END will clear to end of the field.

Valid entries for Transmit/Receive frequencies (TX/RX FREQ), Power Level, Transmit/Receive PL codes (TX/RX PL), and Scan list are listed below:

Data Field Allowed Entries

TX /RX FREQ	Minimum and maximum values are dependent on the frequency range you had selected in the CREATE RPF screen. Try to enter frequencies in either 6.25 or 5 kHz steps or a 'B' for BLANK in the TX Freq field for a RECEIVE-only channel.
Power	Select one of four power levels: (L)ow, (M)edium, (H)igh, or (S)pecial. The power level for this channel will correspond to the power level by the same name in the "Align Radio Parameters" Screen.
TX/RX PL	For Carrier Squelch, enter either CSQ or "Spaces". For Tone PL codes, enter either the frequency in Hertz as XXX.X or as a two digit alpha code. For Digital PL codes, enter the three digit DPL code word (Note: no decimal places may be entered for DPL). RX PL and Quik- Call II are incompatible on a channel. See Appendix 7 for a complete list of squelch codes.
Scan List	Valid entries range from 1 - 10.
Time Out Timer	Valid entries are 'Y' and 'N'. This field will be displayed if H251/H901 is selected. If 'Y' is entered, the time out timer value the radio option screen will be used to limit the length of transmission. If 'N' is entered, the length of transmission is unlimited.
MDC ID on PTT	Valid entries are 'Y' and 'N'. This field will be displayed if H958/H959/H961/H962/H963/H967/H923/H946 is selected. If 'Y' is entered, the MDC ID will be sent out preceding all transmissions on this channel.
Emergency Revert	Valid entries are 'Y' and 'N'. This field will be displayed if H961/H962/H963/H967/H923/H946 is selected. This field determines the Emergency capability for this channel.
Enable XL	Valid entries are 'Y' and 'N'. This field will be displayed for Secure model radios.
Channel Strapping	Possible entries are c (for clear), s (for secure), and blank (to follow switch

Quik-Call II	Valid Entries are 'Y' and 'N'. This field will be displayed if H701/H702/H703 is selected. RX PL and Quik-Call II are incompatible on a channel.
Repeater Index	The Serial Number of the repeater unit ID in the Repeater Access Codes table entered in the radio\options screen. (Can be viewed while in the channel information screen using the F6 key). Example: If you want to send an Access Code of 2357 through either (or both) of the RATS, and if 2357 was entered by you as the 5th entry in the table earlier, then enter 5 for Repeater Index in the channel information screen. You will also need to tie either (or both) the RATs to 'M' for this entry to be effective. (The index is same for RAT1 and RAT2.) This field will be displayed only if either one of the Multiple Repeater Access options is chosen.
RAT1 Function	Valid entries are 1 or 2 (for single tones 1 or 2), M (for Repeater Access Code (MDC)), and ' ' for no signalling. This field will be displayed only if the general single tones option , or one of the Multiple Repeater Access options is chosen.
RAT2 Function	Valid entries are 1 or 2 (for single tones 1 or 2), M (for Repeater Access Code (MDC)), and ' ' for no signalling. This field will be displayed only if the general single tones option , or one of the Multiple Repeater Access options is chosen.
PTT Function	Valid entries are 1 or 2 (for single tones 1 or 2), M (for MDC), and " for no signalling. This field will be displayed only if the general single tones option is chosen and the time duration is not zero. (The MDC ID field does not appear with this field. Instead, the PTT field itself can be used for signalling MDC through PTT -- by entering M in the PTT field.)
Pre/Deemphasis	Valid entries are 'Y' and 'N'. This field is always displayed for any Saber Models. This field is used when a flat audio signal is desired during transmit and receive. Selecting 'Y' (Default) disables flat audio on this channel.
MDC Decode	Valid entries are 'Y' and 'N'. This field will be displayed if a Unit ID (meaning any MDC ENCODE/DECODE option) is present and the Master 8D option is highlighted. Selecting 'Y' enables MDC Decode features on this channel. MDC Decode is incompatible with Tx Inhibit.
Emergency PTT	Valid entries are 'Y' and 'N'. This field will be displayed if Emergency Call is selected. Selecting 'Y' will cause the MDC ID to be transmitted whenever the radio is in Emergency Call.
DOS Muting	Valid entries are 'Y' and 'N'. This field will be displayed if a Unit ID (meaning any MDC ENCODE option) is present and the Master 8D (Advanced STATALERT) option is highlighted. Selecting 'Y' enables DOS Muting on this channel.

Tx Inhibit

Valid entries are 'Y' and 'N'. This field is always displayed if the 8D Master option is selected. Rx PL must be enabled on a channel to get Tx inhibit on the same channel. Tx INHIBIT is incompatible with MDC DECODE.

Press F10 to exit this function or ESC to go back to the MAIN menu. Each function key is described below.

Function Key Descriptions:

F2 Enter Channel - This function moves the cursor to the field label "Channel." If you have channel display names, you may enter them here. Use the UP/DN arrow keys to move to the channel you want to name, and type in the channel name. This field is also used to add/delete and copy channels -- to return to normal channel data entry, press RETURN at any time. The function keys are described as follows:

F3 Insert Channel - This function key allows you to insert a new channel and will prompt you with a channel name. You may continue to modify any of the remaining entries by pressing ENTER.

F4 Delete Channel - In order to delete a channel, the programmer will first prompt you with a statement to be sure you want to delete the present channel. Press 'y' for yes or 'n' for no.

F5 Print - This print function allows you to print out the channel information for this present screen.

F8 Copy Channel - This copy function copies all the data from the marked channel to the current channel. All entries may still be modified.

F9 Mark Channel - This function places an asterisk (*) by the current channel. All data for the channel will temporarily be placed in memory. This function allows you to quickly duplicate similar channels. Pressing F9 again will remove the asterisk, as this function acts as a toggle to enable/disable the marked channel.

Note: In order to copy information from one channel to numerous other channels, first mark the channel with all the proper data, and press the copy channel.

F3 Enter Zone - This function moves the cursor to the field labeled "Zone." If you have zone display names, you may enter them here. Use the UP/DN arrow keys to move to the zone you want to name, and type in the zone name. This field is also used to add/delete and copy zones -- to return to normal zone data entry, press RETURN at any time. The function keys are described as follows:

- F6 Delete Zone - In order to delete a zone, the programmer will first prompt you with a statement to be sure you want to delete the present zone. Press 'y' for yes and 'n' for no.
- F7 Insert Zone - This function key allows you to insert a new zone. You may continue to modify any of the remaining entries by pressing ENTER.
- F8 Copy Zone - This copy function copies all the data from the marked zone to a new zone that will be inserted after the current zone. All entries may still be modified.
- F9 Mark Zone - This function places an asterisk (*) by the current zone. The basic use for this function allows you to insert a new zone and copy all data quickly and efficiently from the marked zone. Pressing F9 again will remove the asterisk, as this function acts as a toggle to enable/disable the marked zone.

Note: In order to copy information from one zone to numerous other zones, first mark the zone with all the proper data, press the copy zone key.

F4 Wide View - This function allows you to view all channels previously defined. By pressing F4, another screen display will come up listing all zones/channels with their attributes or channel information. See Figure 28 for the Wide View screen.

MOTOROLA Radio Service Software SABER Model Ver. R07.01.00 Main.Create/Modify.Zone	Use PgUp / PgDn to change zones. UP / DWN arrow to select channels. Press F4 to return to channel entry.																																				
VIEW ZONE Zone: 01																																					
<table style="width: 100%; border-collapse: collapse;"> <tr> <td style="width: 5%;">01.</td> <td style="width: 20%;">14600000</td> <td style="width: 10%;">CSQ</td> <td style="width: 20%;">15400000</td> <td style="width: 10%;">CSQ</td> <td style="width: 45%;">T.....</td> </tr> <tr> <td>02.</td> <td>14600000</td> <td>CSQ</td> <td>15400000</td> <td>CSQ</td> <td>T.....</td> </tr> <tr> <td>03.</td> <td>14600000</td> <td>CSQ</td> <td>15400000</td> <td>CSQ</td> <td>T.....</td> </tr> <tr> <td>04.</td> <td>14600000</td> <td>CSQ</td> <td>15400000</td> <td>CSQ</td> <td>T.....</td> </tr> <tr> <td>05.</td> <td>14600000</td> <td>CSQ</td> <td>15400000</td> <td>CSQ</td> <td>T.....</td> </tr> <tr> <td>06.</td> <td>14600000</td> <td>CSQ</td> <td>15400000</td> <td>CSQ</td> <td>T.....</td> </tr> </table>		01.	14600000	CSQ	15400000	CSQ	T.....	02.	14600000	CSQ	15400000	CSQ	T.....	03.	14600000	CSQ	15400000	CSQ	T.....	04.	14600000	CSQ	15400000	CSQ	T.....	05.	14600000	CSQ	15400000	CSQ	T.....	06.	14600000	CSQ	15400000	CSQ	T.....
01.	14600000	CSQ	15400000	CSQ	T.....																																
02.	14600000	CSQ	15400000	CSQ	T.....																																
03.	14600000	CSQ	15400000	CSQ	T.....																																
04.	14600000	CSQ	15400000	CSQ	T.....																																
05.	14600000	CSQ	15400000	CSQ	T.....																																
06.	14600000	CSQ	15400000	CSQ	T.....																																
<table style="width: 100%; border-collapse: collapse;"> <tr> <td style="width: 10%;">F1</td> <td style="width: 10%;">F2</td> <td style="width: 10%;">F3</td> <td style="width: 10%;">F4</td> <td style="width: 10%;">F5</td> <td style="width: 10%;">F6</td> <td style="width: 10%;">F7</td> <td style="width: 10%;">F8</td> <td style="width: 10%;">F9</td> <td style="width: 10%;">F10</td> </tr> <tr> <td>HELP</td> <td></td> <td></td> <td>ZOOM</td> <td>PRINT</td> <td></td> <td></td> <td></td> <td></td> <td>EXIT</td> </tr> </table>		F1	F2	F3	F4	F5	F6	F7	F8	F9	F10	HELP			ZOOM	PRINT					EXIT																
F1	F2	F3	F4	F5	F6	F7	F8	F9	F10																												
HELP			ZOOM	PRINT					EXIT																												

Figure 28. Wide View Screen

The list of all possible data displayed on the channel information includes:

T = Time Out Timer
M = MDC ID Enabled
R = Emergency Revert Channel
C = Channel Strapped CLEAR
S = Channel Strapped CODED
X = Secure Range Extension Enabled
n = Assigned Scan List (if any) (2 Characters long)
Q = Quik-Call II
F = Flat Audio Enabled
D = MDC Decode ENABLED
P = Emergency PTT
O = DOS MUTING
I = Transmit INHIBIT on BUSY CHANNEL
1-8 : Repeater Index
1/2/M : RAT1
1/2/M : RAT2
1/2/M : PTT

If a given attribute is not assigned or disabled, then a period "." is printed in its place. By moving the cursor to the specified zone/channel and pressing **F4** or **ZOOM**, the complete channel information screen on that channel will be displayed.

- F5 Print** - This print function allows you to print out all the channel DC ID Table - This function key displays the Repeater Access Codes (MDC) if any of the Multiple Repeater Access Codes options were chosen.
- F7 Copy Freq** - This function key will copy the frequency entered from TX FREQ to RX FREQ and vice versa.
- F8 Copy PL** - This function key will copy the PL entered from TX PL to RX PL and vice versa.

D. Auto Dial / Access and Hangup Codes

In order to access the Auto Dial menu, Option H368 must have been selected in the Radio Feature Options Screen. For every Auto Dial entry, the following information must be entered: Telephone #, Name of person, Access Code, Hangup Code, Zone, and Channel. Use the ENTER key to move between fields or use the UP/DN arrow keys to scroll through the existing list. See Figure 29 for the screen that will come up for Auto Dial. For some Radio models, Access and Hangup codes must be entered on the Manual Telephone Interconnect screen. In those cases, the Access and Hangup prompts will be absent from this screen.

MOTOROLA Radio Service Software SABER Model: Ver. R07.01.00 Main.Create/Modify.Dial	Use UP/DWN arrow keys to select or Enter NUMBER.																				
AUTODIAL SETUP																					
Telephone #: Access Code: Zone:	Name: Hangup Code: Channel:																				
<table style="width: 100%; border-collapse: collapse;"> <thead> <tr> <th style="text-align: left;">ZN/Ch</th> <th style="text-align: left;">Number</th> <th style="text-align: left;">Name</th> <th style="text-align: left;">Access</th> <th style="text-align: left;">Hangup</th> </tr> </thead> <tbody> <tr> <td colspan="5" style="text-align: center; padding: 5px;"> <Empty List> </td> </tr> </tbody> </table>		ZN/Ch	Number	Name	Access	Hangup	<Empty List>														
ZN/Ch	Number	Name	Access	Hangup																	
<Empty List>																					
<table style="width: 100%; border-collapse: collapse;"> <tr> <td style="text-align: center;">F1</td> <td style="text-align: center;">F2</td> <td style="text-align: center;">F3</td> <td style="text-align: center;">F4</td> <td style="text-align: center;">F5</td> <td style="text-align: center;">F6</td> <td style="text-align: center;">F7</td> <td style="text-align: center;">F8</td> <td style="text-align: center;">F9</td> <td style="text-align: center;">F10</td> </tr> <tr> <td style="text-align: center;">HELP</td> <td></td> <td style="text-align: center;">ADD ENTRY</td> <td style="text-align: center;">DELETE ENTRY</td> <td style="text-align: center;">PRINT</td> <td></td> <td></td> <td></td> <td></td> <td style="text-align: center;">EXIT</td> </tr> </table>		F1	F2	F3	F4	F5	F6	F7	F8	F9	F10	HELP		ADD ENTRY	DELETE ENTRY	PRINT					EXIT
F1	F2	F3	F4	F5	F6	F7	F8	F9	F10												
HELP		ADD ENTRY	DELETE ENTRY	PRINT					EXIT												

Figure 29. Autodial Setup Screen

Valid Entries:

Phone Number:	Digits 0 - 9 and Characters P, #, and *.
Name:	Characters A - Z, #, *, "_ " (underscore), " " (blank) and Digits 0 - 9.
Channel:	Digits 0 - 9.
Zone:	Digits 0 - 9.
Access/Hangup Codes:	Digits 0 - 9 and Characters P, #, and *.
Access Code:	Digits 0 - 9 and Characters P, #, and *.
Hangup Code:	Digits 0 - 9 and Characters P, #, and *.

Function Key Descriptions:

- F3 Add Entry** - The Add entry function key will re-prompt you for a new autodial entry and return the cursor to Telephone # . For every additional entry, be sure to include all the required information. Note, the access and hangup codes both have a maximum of eight characters available to be entered. Below the dotted line each entry will be listed as entered.
- F4 Delete Entry** - This function will delete the present auto dial entry. The program will prompt you to be sure you want to delete the entry, type in 'y' for yes and 'n' for no.
- F5 Print** - This function will make a hard copy of the autodial setup screen.

E. Manual Interconnect Access and Hangup Codes

The Manual Interconnect menu is shown in Figure 30. Simply enter the the Access Code and Hangup Code using the ENTER key to move between the selections. Both Codes have a possible eight character field. The only Function Key Description for this menu is the PRINT function (F5), which makes a hard copy of the Manual Interconnect Access and Hangup screen.

MOTOROLA Radio Service Software SABER Model: Ver. R07.01.00 Main.Create/Modify.Access	Use UP/DWN arrow keys to select or Enter ACCESS CODE.								
<u>MANUAL TELEPHONE INTERCONNECT</u>									
Access Code:	Hangup Code:								
F1 HELP	F2	F3	F4	F5 PRINT	F6	F7	F8	F9	F10 EXIT

Figure 30. Manual Telephone Interconnect Screen

F. Format Scan Lists

The Format Scan List menu is only available for a Scan Capable radio. This option allows you to define your scan lists, priority channels, designated transmit channels, as well as all non-priority channels. You must set up your channels before using this screen. Note that while entering channel information for the first time you will not be allowed to select any scan list in the channel screen. After you have created your scan lists, you may return to the channel information, and make your scan list selections.

1. Enter all channels without reference to scan lists.
2. Enter scan lists.
3. Return to the channel information screen to slave channels to a scan list.

This two phase process is to prevent channels from referencing non-existent scan lists, and to prevent scan lists from referencing non-existent channels.

For a description of how some of the Scan options work, see Appendix-5 on Options list and definitions. Figure 31 displays the CREATE/MODIFY SCAN LISTS screen with all possible entries shown for a Zone/Channel radio. A similar screen will come up for a Channel only radio with only channel data entries. You can have up to ten non-priority channels in a scan list with at least one non-priority channel entered to define a list. Use the ENTER key to move between entries and the UP/DN arrow keys to select which scan list you wish to modify. After defining all non-priority channels, press ENTER and define your priority channels if applicable.

MOTOROLA Radio Service Software SABER Model: Ver. R07.01.00 Main.Create/Modify.Scan	Use UP / DWN arrows to select scanlists or enter a zone number.																				
CREATE / MODIFY SCANLISTS																					
Scanlist #: 01	Total Scanlists : 00																				
Priority 1: __ / __ Priority 2: __ / __ Designated TX: __ / __																					
Non - Priority																					
<table style="width: 100%; border: none;"> <tr> <td style="text-align: center;">1</td> <td style="text-align: center;">2</td> <td style="text-align: center;">3</td> <td style="text-align: center;">4</td> <td style="text-align: center;">5</td> <td style="text-align: center;">6</td> <td style="text-align: center;">7</td> <td style="text-align: center;">8</td> <td style="text-align: center;">9</td> <td style="text-align: center;">10</td> </tr> <tr> <td style="text-align: center;">_ / _</td> <td style="text-align: center;">_ / _</td> <td style="text-align: center;">_ / _</td> <td style="text-align: center;">_ / _</td> <td style="text-align: center;">_ / _</td> <td style="text-align: center;">_ / _</td> <td style="text-align: center;">_ / _</td> <td style="text-align: center;">_ / _</td> <td style="text-align: center;">_ / _</td> <td style="text-align: center;">_ / _</td> </tr> </table>		1	2	3	4	5	6	7	8	9	10	_ / _	_ / _	_ / _	_ / _	_ / _	_ / _	_ / _	_ / _	_ / _	_ / _
1	2	3	4	5	6	7	8	9	10												
_ / _	_ / _	_ / _	_ / _	_ / _	_ / _	_ / _	_ / _	_ / _	_ / _												
<table style="width: 100%; border: none;"> <tr> <td style="text-align: center;">F1</td> <td style="text-align: center;">F2</td> <td style="text-align: center;">F3</td> <td style="text-align: center;">F4</td> <td style="text-align: center;">F5</td> <td style="text-align: center;">F6</td> <td style="text-align: center;">F7</td> <td style="text-align: center;">F8</td> <td style="text-align: center;">F9</td> <td style="text-align: center;">F10</td> </tr> <tr> <td style="text-align: center;">HELP</td> <td></td> <td></td> <td style="text-align: center;">DELETE SCANLIST</td> <td style="text-align: center;">PRINT</td> <td style="text-align: center;">DELETE ENTRY</td> <td></td> <td></td> <td></td> <td style="text-align: center;">EXIT</td> </tr> </table>		F1	F2	F3	F4	F5	F6	F7	F8	F9	F10	HELP			DELETE SCANLIST	PRINT	DELETE ENTRY				EXIT
F1	F2	F3	F4	F5	F6	F7	F8	F9	F10												
HELP			DELETE SCANLIST	PRINT	DELETE ENTRY				EXIT												

Figure 31. Create/Modify Scan Lists Screen

While scanning, all **non-priority channels** have equal status. That is, once activity is detected on a non-priority channel, the scanning of other non-priority channels is stopped until carrier is dropped. The radio will continue to scan priority one and priority two however. If activity is detected on either of the priority channels, the radio will drop the non-priority channel and begin monitoring the priority channel.

Priority one is the highest priority entry on the list. The radio will monitor activity on this channel at all times. When the radio detects activity on the priority one channel, scan will monitor the priority one channel exclusively, until carrier is dropped and then it will resume normal scan.

Priority two is the second highest priority on the list. When the radio detects activity on the priority two channel, but not on the priority one channel, scan will move to the priority two channel, but continue to monitor the priority one channel. When carrier is dropped on the priority two channel, scan will resume as normal.

Note: If MDC is enabled with Scan and a priority channel is set to be scanned or the radio is equipped with a priority scan encryption module, DOS Muting will not work properly.

The **designated transmit channel** defines the zone/channel combination that the radio will transmit on whenever the PTT switch is pressed while the current list is being scanned.

Function Key Descriptions

- F4 Delete Scan list** - The Delete Scan list function will delete the present scan list being modified or created including all data present.
- F5 Print** - This print function will make a hard copy of the Scan list menu.
- F6 Delete Entry** - The Delete Entry function will delete the entry where the cursor is positioned. If you delete a non-priority channel in the middle of a non-priority scan list, then each entry after the deleted entry will be moved up one position.

G. Format Selectable PL

The Format Selectable PL screen shown in Figure 32 will only come up if option H649 is selected in the Radio Options Screen. The only data you enter are the PL CODE, and NAME, and the programmer will keep track of how many PL codes have been entered and what entry you are presently modifying or creating. The programmer will also list all entries to date. Use the UP/DOWN arrow keys to scroll through the CURRENT ENTRY NUMBER list to modify a particular PL Code entry. Use the ENTER key to move from one entry to the next.

MOTOROLA Radio Service Software SABER Model Ver. R07.01.00 Main.Create / Modify.Sel PL	Use UP / DWN arrow keys to select row. Enter PL Code.																				
CREATE / MODIFY SELECTABLE PL CODES																					
Total Entered: Enter PL Code:	Current Entry Number: Enter Name:																				
<table style="width: 100%; text-align: center; border-collapse: collapse;"> <tr> <td style="width: 10%;">F1</td> <td style="width: 10%;">F2</td> <td style="width: 10%;">F3</td> <td style="width: 10%;">F4</td> <td style="width: 10%;">F5</td> <td style="width: 10%;">F6</td> <td style="width: 10%;">F7</td> <td style="width: 10%;">F8</td> <td style="width: 10%;">F9</td> <td style="width: 10%;">F10</td> </tr> <tr> <td>HELP</td> <td></td> <td>INSERT PL</td> <td>DELETE PL</td> <td>PRINT SCREEN</td> <td></td> <td></td> <td></td> <td></td> <td>EXIT</td> </tr> </table>		F1	F2	F3	F4	F5	F6	F7	F8	F9	F10	HELP		INSERT PL	DELETE PL	PRINT SCREEN					EXIT
F1	F2	F3	F4	F5	F6	F7	F8	F9	F10												
HELP		INSERT PL	DELETE PL	PRINT SCREEN					EXIT												

Figure 32. Create/Modify Selectable PL Codes

Valid Entries:

See Appendix 7 for a complete list of squelch codes.

Function Key Descriptions:

- F3 Insert PL** - This function key allows you to insert another PL code (up to 9) and the Current Entry Number field will automatically be incremented as will the Total when the present PL entry is completed.
- F4 Delete PL** - This function key will delete a particular PL entry. Use the UP/DOWN arrow keys to scroll through your entries. Be sure of the PL code entry you wish to delete because the programmer will NOT prompt you before deletion. The existing list of PL codes will be updated and move up in the list when a PL entry is deleted.
- F5 Print Screen** - This function key will create a hard copy of this screen shown in Figure 32.

IX. PRINT RADIO PERSONALITY

The PRINT function is used to produce permanent records of codeplug configurations. A printer is required and should be connected to your computer per your computer user's manual. Figure 33 displays the screen that comes up if you choose the Print Radio Personality function from the MAIN menu.

MOTOROLA Radio Service Software SABER Model: Ver. R07.01.00 Main.Print	Select Function Key F1 - F10								
<u>PRINT RADIO PERSONALITY MENU</u>									
F1 - Help on Printing F2 - Print Channel Information Form F3 - Print Auto Dial Form F4 - Print Radio Options F5 - Print Selectable PL F6 - Print Scan Lists F7 F8 F9 F10 - Exit									
F1 HELP	F2 CHAN INFO	F3 AUTO DIAL	F4 OPT LIST	F5 SELECT PL	F6 SCAN LIST	F7	F8	F9	F10 EXIT

Figure 33. Print Menu

Function Key Descriptions:

- F2 Print Channel Information Form** - This function creates a hard copy of the information entered in the Channel Information Screen: channel name, zone name, TX / RX frequencies, TX / RX codes, emergency, etc...
- F3 Print Auto Dial Form** - This function key creates a hard copy of information entered in the Auto Dial Form providing information on phone number, person called, access and hangup codes, and which zone and channel each number corresponds to.
- F4 Print Radio Options** - This function key creates a hard copy of Radio Options available. For a copy of Radio Option Descriptions, make a hard copy of the Appendix A-5 which gives detailed descriptions on each available option.
- F5 Print Selectable PL** - This function creates a hard copy of the information entered in the Selectable PL screen, listing the PL codes and names for which each PL Code belongs.
- F6 Print Scan lists** - This function creates a hard copy of the information entered in the Scan list screen providing information on a scan list with priority channels, designated transmit channel, and non-priority channels if appropriate.

APPENDIX - 1. ERROR MESSAGES

In the SABER display radio models, the radios will display error messages under two conditions.

1. When the radio is turned on, and there exists an error condition in the radio, the radio will display an error message of the form **ERR x yz** for approximately 2 seconds before attempting to show the default display which is either the channel name or number (in a channel only radio) or the zone and channel names or numbers (in a zone radio).
2. The error message will also be shown on the display and remain on the display until the radio is turned off (or the radio is reset by the SABER RADIO SERVICE SOFTWARE) under the following conditions.
 - With the radio turned off, press and hold the MENU, SELECT and ENTER keys simultaneously.
 - Turn the radio on while still holding the 3 keys pressed down.
 - for a COPE 4 (A & B radio):
The display should show a message of the form **ERR x yz**. This message should remain on the display even when you release the 3 keys. If the message does not remain on the display (or does not appear at all), then you have not pressed the keys simultaneously. You will have to turn off the radio and repeat the procedure until the message remains on the display.
 - * for a COPE 5 (C radio):
A full eight-character display should appear for this radio unless there really is an error.

The following paragraphs will describe the meaning of the error messages. The error message has the form **ERR x yz**, where **x** is the address of the device with the error and **yz** is the error condition.

x can take on one of 3 values:

0	-	CORE microprocessor
1	-	COPE microprocessor
2	-	external EEPROM on display board.

yz can take on the following values (note that these values are hexadecimal numbers)

- 00 - no error
- 01 - internal EEPROM checksum error. This means that the data in the internal EEPROM could be corrupted or the checksum value itself could be wrong. If several reprogramming attempts do not eliminate this error, then the related microprocessor must be replaced. Applicable to COPE and CORE.
- 02 - RAM read/write error. This means that an error was detected while the processor was attempting to read from, or write into, microcomputer RAM (random access memory or scratchpad memory). This indicates that the related microprocessor is faulty and should be replaced. Applicable to COPE only.

- 04 - external EEPROM checksum error. This means that the data in the external EEPROM could be corrupted or the checksum value itself could be wrong. If several reprogramming attempts do not eliminate this error, then the external EEPROM must be replaced. Applicable to COPE only.
- 08 - blank internal EEPROM. This means that the internal EEPROM is blank (all locations contain the hexadecimal value FF). Reprogram the radio. If unsuccessful, replace the related microprocessor. Applicable to COPE only.
- 10 - ROM checksum error. This means that the read-only-memory (ROM) of the related microprocessor has an error. Replace the faulty microprocessor. Applicable to COPE only.
- 20 - Hardware error. This means that the external EEPROM is faulty. Replace the external EEPROM and reprogram the radio. Applicable to COPE only.

The above listing contains the basic errors that can be displayed to the user. However, if more than one error occurs simultaneously, the error message is simply an addition of the values of the errors involved. A few examples will clarify this. Note that since the error values are hexadecimal, the addition will also result in hexadecimal values. Some examples of common error messages are given below.

Error message examples:

- ERR 0 X1** - The CORE μ P has an internal EEPROM checksum error. (X may be any value)
- ERR 1 01** - The COPE μ P has an internal EEPROM checksum error.
- ERR 1 03** - The COPE μ P has an internal EEPROM checksum error as well as a RAM read/write error.
- ERR 1 0B** - The COPE μ P has a RAM read/write error as well as a blank internal EEPROM and internal checksum error. (01 + 02 + 08 = 0B in hexadecimal).
- ERR 1 24** - There is an external EEPROM and hardware error as well as an external EEPROM checksum error.
- ERR 1 30** - The COPE μ P has a ROM checksum error and the external EEPROM has a hardware error. (10 + 20 = 30 in hexadecimal.)
- ERR 1 00** - The radio has no errors.
- ERR 1 0D** - The display that comes up for a COPE 5 radio when the programmer starts writing to the radio.

APPENDIX - 2. KEYBOARD COMMANDS

All Radio Service Software keyboard commands are summarized in this section. The F1 HELP function also provides keyboard information. From any screen, you may view this list by pressing F1 (HELP) and then press F2 (KEYBOARD HELP).

F1:	Help Information
F2 - F8:	Execute Labeled Function
F10:	Return to the PREVIOUS Menu
ESC:	Return to the MAIN Menu
TAB (or ENTER) :	Advance Cursor to Next Data Field
Shift TAB:	Backup Cursor to Last Data Field
UP / DOWN Arrow Keys:	Increment / Decrement Value or Selection
PGUP/PGDN:	Increase the Increment / Decrement Speed
LEFT / RIGHT Arrow:	Move Cursor Within Data Field
INSERT:	Insert Space at Current Cursor Position
BACKSPACE:	Erase Data Within Field & Move Cursor Left
DELETE:	Erase Current Character
HOME:	Move Cursor To Upper Left Data Field
END:	Move Cursor To Lower Right Data Field
PAGE UP / PAGE DN:	Change Displayed Page

APPENDIX - 3. How To Format A Disk

A disk must be prepared or initialized to a specific recording format before your computer's disk operating system (DOS) can read information from it or save information to it. This initialization process is called 'formatting.' You must format all new disks before using them with your computer.

You format a disk using your computer's DOS FORMAT utility. Refer to your computer owner's manual and your DOS manual for additional information about the FORMAT procedure.

WARNING: The Format procedure will destroy any previously existing information on the disk. Always double check to be sure that you have placed the correct disk in the drive BEFORE you begin the FORMAT procedure.

A. Dual-Floppy Disk Drive Systems

To format a disk with a dual-floppy disk system, place your DOS System disk in drive A: and place the disk to be formatted in drive B: . Next type:

```
A: FORMAT B: /V          [Press Enter]
```

After the disk is formatted, you will be prompted to give the disk a volume label to uniquely identify the disk. The volume label may consist from 1 to 11 characters.

B. Hard Disk Systems

To format a disk with a hard disk system, log on to the sub-directory that contains your DOS files (specifically the FORMAT.COM file). for example, if your DOS files are installed on a sub-directory called SYSDOS, change to this sub-directory by typing:

```
C: CD \SYSDOS          [Press Enter]
```

Place the disk to be formatted in drive A: and type:

```
C: FORMAT A: /V       [Press Enter]
```

After the disk is formatted, you will be prompted to give the disk a volume label to uniquely identify the disk. The volume label may consist of from 1 to 11 characters.

APPENDIX - 4. SABER Models

There are numerous versions of models for the SABER radio. The three basic models are the SABER I, SABER II, and SABER III. All radio models follow the generic model number listed below with each variable explained following.

		Habccdefghij	
1.	When the field	'a' = 4 'a' = 3	then Power = High then Power = Low
2.	When the field	'b' = 2 'b' = 3 'b' = 4	then Band = Mid-Band then Band = VHF then Band = UHF
3.	When the field	'cc' = SA 'cc' = QX 'cc' = YB 'cc' = YX	then the radio is a standard portable then the radio has voice privacy then the radio is submersible then the radio is submersible with voice privacy
4.	When the field	'd' = N 'd' = J 'd' = K 'd' = G	then no keypad then Display II is present (3 button keypad) then Display III is present (full keypad) then SABER IE (Talkaround or two zone, no display)
5.	When the field	'e' = 7 'e' = 9	then CORE = Binary (U.S. models) then CORE = TONE (International models)
6.	When the field	'f' = 1 'f' = 5	then radio = wide band then radio = 12.5 or narrow band (Int'l models)
7.	When the field	'g' = 0 'g' = 3	then radio is 10 channel capable (Int'l models) then radio is 12 channel capable
8.	When the field	'h' = 9	(Model variation)

APPENDIX - 5. Options List and Definitions

H251 - 60 Second TOT

This option will limit the transmitting period to 60 seconds. The radio will automatically stop transmitting when the timer goes off and will generate an alert tone to notify you that no transmission is taking place. Release the PTT button located on the left side panel of the radio to disable alert tone. If you wish to have TOT value to be lesser or greater than 60 seconds, choose option H901.

H901 - Non-standard TOT

This option will limit transmitting period to any TOT value within the valid range of 1 second to 255 seconds, incrementing by one second. If you enter a TOT value of 60 seconds, H901 will automatically be deselected and option H251 will be selected for you by default since that option implements the standard 60 seconds. After exceeding the preset TOT value, the radio will stop transmitting and will generate an alert tone notifying you of its non-transmitting status.

Silent Monitor – Selecting this option will enable Silent Monitor in the radio. This option is primarily used on PL/DPL Coded Squelch Radios. Its purpose is to remove white noise when pressing the monitor button on the side of the radio. The audio will only unmute, if a carrier is present on the channel you are monitoring.

H384 - Muting Via Keypad

Selecting this option will allow you to mute the alert tones generated by the keypad in the radio.

H153 - Omit All Tones

Selecting this option will cause the radio not to generate any alert tones or sidetones. Audio feedback by the radio is muted. If you choose this option, the programmer will not allow you to select option H619, which omits only side tones.

H365 - Transmit Inhibit on Busy Channel

Selecting this option will prevent you from transmitting on the channel if carrier is present and the correct PL is not. This option can be enabled on all channels that have PL. If you try to transmit while carrier is present the radio will generate an alert tone. This option also prevents use of the monitor button.

Note: For a carrier squelch channel, this option does not inhibit transmission, even if the channel is busy. Also the monitor function will be disabled on all channels if this option is selected.

H359 - Channel Busy LED (Option H906 becomes disabled)

The red LED performs two mutually exclusive functions: it indicates the low battery status and channel busy indicator. Selecting this option eliminates the low battery status indicator and the LED functions as a channel busy LED. The LED will blink when carrier is detected on the channel. While transmitting, the LED will either be ON if enabled or OFF if disabled.

H906 - Low Battery LED

The top mounted red LED performs two main mutually exclusive functions --it indicates the low battery status and channel busy indicator. Selecting this option eliminates the Channel Busy LED indication and the LED functions as a low battery indicator.

Safe Battery (H155, H200, H237, H759)

This option should ONLY be selected if you have an intrinsically safe battery. The battery options supported include:

- H155AB - CENELEC
- H200AC - SAA
- H237AB - CSA
- H759AG - FM (Groups C, D, E, F, G)

Failure to include this option when using an intrinsically safe battery is characterized by a premature indication of a low-battery condition. For SABER I radios (no display), this option is only required when option H906 (low battery LED) is selected.

H958 - Unit ID - MDC 600

Selecting this option defines an MDC 600 ID to the radio, where 600 refers to a 600 baud rate. The portable user can send out his unit ID whenever PTT is activated, deactivated, or both. There will be one unit ID per radio channel. The transmission of the user's ID will allow the base operator to track voice communications on a given channel. Sidetones will be heard (if enabled) while the ID is being transmitted. You can enter a 4 digit hexadecimal ID in the range from 0001 to DEEE, excluding any occurrence of a hexadecimal F. Trailing Unit ID is not available on secure radios.

H959 - Unit ID - MDC 1200

Selecting this option defines an MDC 1200 ID to the radio, where 1200 refers to a 1200 baud rate. This option's description is identical to that of MDC 600 (H958) except for the baud rate of 1200.

H961 - Unit ID and Emergency - MDC 600

This option allows you to enter a unit hexadecimal ID for MDC 600 in the range from 0001 to DEEE, excluding any occurrence of a hexadecimal F. By pressing the emergency button located on the top panel of the radio, the radio goes to the preprogrammed emergency channel and sends out an alarm. If emergency is transmitted while scan is running, the emergency opcodes will go out on the channel that a transmit last occurred (this may or may not be the home channel).

H962 - Unit ID and Emergency - MDC 1200

This option behaves identical to Unit ID and Emergency - MDC 600 (H961) except that it functions at 1200 baud. This option is incompatible with scan options H273 and H344.

H963 - Unit ID W/ Audible Emergency - MDC 600

This option allows you to enter a unit hexadecimal ID for MDC 600 in the range from 0001 to DEEE, excluding any occurrence of a hexadecimal F. You can go to the preset emergency channel by pressing the emergency button located on the top panel of the radio. When the emergency button is pressed, the radio sends out the emergency sequence and simultaneously generates side tones each time the sequence is transmitted. The radio will remain on the emergency channel unless you press PTT to transmit. If emergency is transmitted while scan is running, the emergency opcodes will go out on the channel that a transmit last occurred (this may or may not be the home channel).

H967 - Unit ID W/ Audible Emergency - MDC 1200

This option behaves identically to Unit ID W/ Audible Emergency - MDC 600 (H963), except that it functions for 1200 baud. If emergency is transmitted while scan is running, the emergency opcodes will go out on the channel that a transmit last occurred (this may or may not be the home channel).

H923 - Unit ID W/Emergency Revert - MDC 600

This option allows you to enter a unit hexadecimal ID for MDC 600 in the range from 0001 to DEEE, excluding any occurrence of a hexadecimal F. By pressing the emergency button located on the top panel of the radio, the radio goes to the preprogrammed emergency channel, one for each zone, transmits a silent alarm, and then reverts back to the channel that you were on. A total of 20 emergency packets are sent each time emergency is pressed. This option is incompatible with H707.

H946 - Unit ID W/Emergency Revert - MDC 1200

This option behaves identically to Unit ID W/Emergency Revert - MDC 600, except that it functions for 1200 baud. This option is incompatible with H707.

No Channel Re-Revert After Emergency – Selecting this option will cause the radio to remain on the reverted channel after the completion of the emergency packet transmissions. Any subsequent transmissions will be sent out the assigned Emergency Revert channel. Cancelling this may be done by manually changing channels or by resetting the radio.

H770 - Pretime Delay - 300ms

Pretime delay is the period of time for which the radio waits before sending out MDC signalling data. Standard pretime delay is 500 ms. Selecting this option will give you a pretime delay of 300 ms. This is applicable to Single Tones and Multiple Repeater Access options also.

This option is incompatible with the following options:

- H771 - Pretime Delay - 700 ms
- H779 - Non-standard Pretime Delay

H771 - Pretime Delay - 700 ms

Pretime delay is the period of time for which the radio waits before sending out MDC signalling data. Standard pretime delay is 500 ms. Selecting this option will give you a pretime delay of 700 ms. This is applicable to Single Tones and Multiple Repeater Access options also.

This option is incompatible with the following options:

- H770 - Pretime Delay - 300 ms
- H779 - Non-standard Pretime Delay

H779 - Non-standard Pretime Delay

Pretime delay is the period of time for which the radio waits before sending out MDC ID. Selecting this option will allow you to enter a pretime delay value between 100 ms to 1000 ms other than 300 ms, 500 ms, and 700 ms. This is applicable to Single Tones and Multiple Repeater Access options also.

H619 - Omit Side Tones

Sidetones are produced to inform the users that they must wait until the MDC packet is transmitted to talk. Unit ID sidetones may be deleted per radio. For emergency encode, sidetones may be optionally enabled per radio in the codeplug. The sidetones will be alert tones of 1640 Hz continuous while the unit ID is being transmitted. Sidetones are a fixed volume level programmable per radio. The microphone is muted during sidetones. Selecting this option will disable all sidetones. This is applicable to Single Tones and Multiple Repeater Access options also. This function is incompatible with option H153 - Omit all tones.

H371 - Zone and Channel Operation

This option provides zone/channel operation in the radio. Zones can be selected through the keypad and channels can be selected using the channel selector switch. Each zone can have a maximum of 12 channels. The maximum number of zones available to you depends on the radio model as shown below:

<u>Radio Model</u>	<u>Max. # of Zones</u>	<u>Total # of Channels</u>
SABER II.2	4	48
SABER II.2 (with Scan)	3	36
SABER II.8	10	120
SABER III	10	120

This option is incompatible with H396 - Channel Only Operation

H396 - Channel Only Operation

Selecting this option will define a channel only radio (i.e. no zones) with channels selected using the keypad. The maximum number of channels available are listed in the following table:

<u>Radio Model</u>	<u>Max. # of Channels</u>
SABER II.2	48
SABER II.8	120
SABER III	120

H560 - Talkaround

Selecting this option will allow talkaround on a SABER IE. Data for one zone can be entered in the channel information screen. This option is incompatible with option H256 (Two Zone Operation).

H256 - Two Zone Operation

Selecting this option will allow two zones on a SABER IE. Data for two zones can be entered in the channel information screen. This option is incompatible with option H560 (Talkaround).

H346 - Zone Display Names

By selecting this option you can customize zone menu names. If option H380 - Channel display names is selected, maximum number of characters you can have is 3. If option H380 is not selected then you can enter up to 5 characters for the zone name. Default zone names are given to all the zones, i.e. 'Z1' for zone 1 and 'Z10' for zone 10.

H380 - Channel Display Names

By selecting this option, you can enter up to 8 characters for every channel name. If H346 - Zone Display Names is selected, then the maximum number of characters per channel name is reduced to 5 characters in order to specify zone name on the display as well. Default channel names are given to all channels, i.e. 'C01' for channel 1 and 'C10' for channel 10.

H368 - Autodial

This option adds autodial capability to the radio. You can specify up to 9 telephone numbers along with their access and hang-up codes for each phone number and zone/channel number on which the call will be made on. This option is available on C model radios only. A and B model radios can have only one access and hang-up code. You will not be able to change the telephone numbers, and access and hang-up codes using the keypad. In order to modify this information, you will have to use the RADIO SERVICE SOFTWARE.

H669 - Omit Inadvertent Lock

Inadvertent lock is a standard menu option for display models. This option will disable the Inadvertent Lock which allows you to lock out the keypad temporarily during periods of non-usage, or for safety purposes to minimize inadvertent actuation.

H670 - Omit Memory (2K memory option)

This option is necessary for SABER II's with a 2K EEPROM instead of the normal 8K. It is important to ensure that the size of the codeplug that is being created does not exceed the bounds of hardware in the radio. Selecting this option will reduce the number of available options.

H297 - Manual Telephone Interconnect

This option allows manual dialing of DTMF telephone numbers. In this feature, you may fix the length of the tones transmitted, or you may select manual length tones.

H397 - Menu Lock

This option will add a menu lock to the radio. With this option you can lock out the keypad from unauthorized users unless the proper password is entered. The password menu is also included in the radio to allow the capability of changing passwords. The default password is the null password which is entered by pressing the **ENTER** key on the radio. You must select option H669 - Omit Inadvertent Lock, to enable this option.

H345 - Radio Lock

This option will allow you to lock the radio when it is first turned on. In order to enable any radio functions or menus, the correct password must be entered otherwise the radio will be inoperable and none of the options or menus can be accessed. The same password in option H397 - Menu Lock, will be used here for A and B model radios. For C model radios, Menu Lock can have different passwords if you wish.

H273 - Operator Selectable Scan

Selecting this option will allow you to enter or modify a unique scan list, using the keypad on the radio, without the aid of the RSS. You can select this option at the same time as option **H344** (mode slaved scan). If both types of scan are present in your radio, you would choose the type of scan that you want to activate by using the three control keys on the keypad. In this option, the number of priority channels (1 or 2) and the designated transmit channel will be user programmable. This option allows you to enter one scan list with 15 entries; this list includes 2 priority channels, 12 non-priority channels, and 1 entry for the designated transmit channel. This option is not offered for SABER II radios because the full keypad is not available in those models.

NOTE: If MDC is enabled on the radio and priority scan is used, DOS Muting will not work properly causing the radio to unsquelch at times during MDC transmissions. This occurs whether scan is running in the radio or not.

H344 - Mode Slaved Scan (for SABER II.8, SABER III)

Selecting this option will give you 10 scan lists with 13 entries per scan list. The 13 entries include 2 priority channels, 10 non-priority channels and 1 optional entry for designated transmit channel. The two priority channels will be scanned more often than the non-priority channels and will continue to be scanned even if a lower priority channel is currently being monitored. If both priority channels are being used, the channel with priority 1 status will be able to override the channel with priority 2 status such that the priority 1 channel will continue to be scanned even if the priority 2 channel is active. The priority 2 channel will not be scanned if the scanner is locked on the priority 1 channel. In any scan list it will be possible to omit either or both of the priority channels. For this type of scan, each channel in the radio points to one of the scan lists, so you can assign a different scan sequence to each channel. All channels and scan lists available in this option are factory programmed, but can be changed with the Radio Service Software.

NOTE: If MDC is enabled on the radio and priority scan is used, DOS Muting will not work properly causing the radio to unsquelch at times during MDC transmissions. This occurs whether scan is running in the radio or not.

2nd Fixed Priority

Standard in the radio is fixed first priority and a floating second priority. This option is available to you to make the second priority status until you transmit on another channel while the radio is scanning with no activity. A second fixed priority can not be offered along with floating priority since the floating priority already assumes 2nd priority status. At scan initialization the floating priority channel will be the same as the preassigned transmit channel until you transmit on some other channel. For each scan list the preassigned transmit channel will always be the channel on which the radio was, when scan was entered. Disable this function if you want second floating priority.

Nuisance Mode Delete

This option allows you to temporarily delete non-priority channels from the scan list that are constantly busy which may cause the scanner to be constantly locked onto a channel. A channel deleted using this option will remain deleted until scan is aborted. When scan is processed again, all channels which were previously deleted will be replaced. You can activate this feature by using the **SELECT** and **ENTER** keys while the radio is locked onto the channel that is to be deleted from the scan list. This option is incompatible with autoscan.

Scroll Scan List

This option allows you to view which channels are programmed into each scan list. Use MENU key to select scroll menu and press the **SELECT** key to scroll through the entire list.

Designated Transmit Mode

This option will force you to transmit on a specific channel anytime the PTT is pressed while scanning regardless of what state the scanner is in. The designated transmit channel will be specified per scan list. If this option is selected along with floating priority, the floating priority channel will always be the designated transmit channel since this is always the channel of transmission. If you do not select this option then for each scan list, transmit channel will always be the channel on which the radio was when scan was entered.

Priority to Follow Channel Selector Switch

Selecting this option will assign priority channel 1 to the position of the channel selector switch. For example, if you are on channel 5 then your priority channel 1 is assigned to channel 5. If you change the position of the channel selector switch while scanning, the radio will exit the scan mode. The channel selected to be the priority channel must be chosen before activating scan.

Autoscan

This option modifies the behavior of mode-slaved scan (H344) such that, when a channel is selected on the radio, scanning will begin immediately if there is a scan list assigned to that channel. This feature is only available in zone/channel radios, and is not compatible with operator-selectable scan.

Required options: H344, H371, H669

Incompatible options: H396, H397, H273, and Nuisance Delete

Mode Slaved Scan (for SABER II.2)

This option is available only in SABER II.2 radios. It allows only 2 scan lists. Selecting this option will give you 2 scan lists with 13 entries per scan list. The 13 entries include: 2 priority channels, 10 non-priority channels, and 1 optional entry for the designated transmit channel. The two priority channels will be scanned more often than the non-priority channels and will continue to be scanned even if a lower priority channel is currently being monitored. If both priority channels are used, the channel with priority 1 status will override a priority 2 channel such that the priority 1 channel will continue to be scanned even if the priority 2 channel is active. In any scan list it will be possible to omit either or both of the priority channels. With this option you can only have 3 zones/36 channels (see option H371 - zone and channel operation). The nuisance mode delete option, scroll scan list option, and autoscan are not available with this option.

H444 - Delete Proper Code Detect

If this option is enabled the radio will mute on any signal. If a coded signal with different key is present the radio will unmute with encrypted data which will sound like noise to the user.

H245 - Delete Clear Mode Alert Tones on Transmit

This option will delete the alert tone that is used to indicate that the radio is transmitting in the clear mode. The frequency of this tone is 820 Hz for a duration of 80 ms. You can only mute this tone using the Radio Service Software.

H244 - Delete Clear Coded Transmit Switch

If your radio is SECURE and does not have a coded/clear selector switch, you must enable this option; otherwise, you may electronically disable this option. If your radio is not a SECURE radio you will not even see this option on the screen. This option is incompatible with option H400 - Secure Voice Slaved to a Mode, when selected all channels are assumed to be "coded."

H400 - Secure Voice Slaved to a Mode

If a channel is strapped coded, the radio will transmit in accordance to its strapping. An invalid switch position tone will sound if the ERGO switch is placed in the Clear position.

This option is incompatible with option H244 - Delete Clear Coded Transmit Switch.

H401 - Clear Voice Slaved to a Mode

If a channel is strapped clear, the radio will transmit in accordance to its strapping. An invalid switch position tone will sound if the ERGO switch is placed in the coded position, unless option H244 is selected, then the ERGO switch position is disregarded.

H432 - VP Capable Only

VP (Voice Privacy) Capable Only option should be used only if the radio is capable of having DVP modulation, but is not equipped with the encryption module. The radio will transmit if the clear/coded switch is in the clear position only. In the coded position the radio will emit a continuous fail alarm, until the switch is moved back to the clear position or an alarm of higher priority (i.e. channel unprogrammed) is requested. If option H244 is selected, then the switch position is disregarded, the radio acts as if it is clear always. If option H432 is selected, a short beep will be heard upon power up.

H852 - 6D Master Option

Selecting this option allows you access to 6D options -- Quik Call, Single Tones (via PTT or RATs or both), Multiple Repeater Access Codes, and Zero Audio Enable. The standard SABER radios are equipped with the 5D version of the microcomputer. The 6D is an enhanced version of the 5D microcomputer. The option H852 acts as a main gate to all the 6D options :

Zero Audio Enable
Quik Call II

- H701 - Individual Call
- H702 - 4 Tone Group Call
- H703 - Long Tone B Group Call
- H167 - Timed Auto Reset
- H188 - Carrier Override Auto Reset
- Singletones - General (PTT/RATs)
- H707 - 1 Tone Singletone Via PTT Button
- H742 - Up to 2 Tone Singletone via RAT Buttons
- Singletone Non-Std. Pretime
- Singletone Time Duration
- Multiple Repeater Access Codes - MDC 600
- Multiple Repeater Access Codes - MDC 1200

Mid-Band radios have this option automatically selected.

The following options are enabled if you select H852 :

Zero Audio Enable
Quik Call II

- Singletones - General (PTT/RATs)
- H707 - 1 Tone Singletone Via PTT Button
- H742 - Up to 2 Tone Singletone via RAT Buttons
- Multiple Repeater Access Codes - MDC 600
- Multiple Repeater Access Codes - MDC 1200

Zero Audio Enable

The Zero Audio Enable option mutes the radio when the volume is set below a certain user-specified value. Selecting this option pops up the window to get the value from you. The valid range is from 0% to 100%. There are some characteristics of this option that you must keep in mind. They are as follows:

1. If the volume is turned down below the value entered in the pop-up window while the radio is in the transmit mode, the radio will not mute until the radio is in the receive mode.
2. If the volume is turned up above the value in the pop-up window while the radio is in the transmit mode, the radio will not return to the normal muting/unmuting state until the radio is in the receive mode.
3. If an alert tone was in progress when the volume is turned up above the user-specified value, the radio will not return to its normal muting/unmuting state until the alert tone is complete.

Quik- Call II™

The Quik- Call II is a receive only function and has two tones/codes associated with it (Tone A and Tone B). The Quik-Call II frequencies range from 288.5 Hz to 2469 Hz. Selecting this option will pop-up a window with five different systems to select from. These systems are listed below. The available frequencies for each system are listed in Appendix - 6. To select a system enter a number corresponding to that system; for example, to select the Plectron system enter 3. The default is set to the Motorola system. You must select this option in order to select any of the Quik-Call II options. Even non-standard frequencies can be used, either independently, or along with any standard system. Transmit inhibit option (H365) is incompatible with the Quik- Call options.

Quik-Call II System Selection:

1. Motorola
2. General Electric
3. Plectron
4. Federal
5. Others - Non Standard System

The following options are enabled if you select this option :

- H701 - Individual Call
- H702 - 4 Tone Group Call
- H703 - Long Tone B Group Call
- H167 - Timed Auto Reset
- H188 - Carrier Override Auto Reset

H701 - Individual Call

To select this option you must select the Quik-Call II option .When option H701 is selected the pop-up window will be displayed on the screen to get the Individual Call frequencies. Individual calls are determined by two tones in sequence, tone A and tone B. The frequency of tone A cannot be equal to the frequency of tone B. The valid range of the Quik-Call II frequency is from 288.5 Hz to 2469 Hz. This option is incompatible with the following options:

- H702 - Two- Tone Group Call
- H703 - Long Tone B Group Call

H702 - Two-Tone Group Call

To select this option you must select the Quik-Call II option. This option can offer Individual call together with Two Tone Group call. When this option is selected the pop-up window will be displayed on the screen to get two different frequencies for individual call and two different frequencies for two-tone group call. Tone A frequency must be different from tone B frequency. The valid range of the Quik Call II frequency is from 288.5 Hz to 2469 Hz. This option is incompatible with the following options:

- H701 - Individual Call
- H703 - Long Tone B Group Call

H703 - Long Tone B Group Call

To select this option you must select the Quik Call II option. This option can offer Individual call along with Long Tone B Group call option. The Individual calls are determined by two sequential tones, tone A and tone B. Remember that tone A cannot be equal to tone B. When this option is selected the pop-up window is displayed on the screen to get two different frequencies for individual call and one tone B frequency for long tone B group call. The valid range of the Quik Call II frequency is from 288.5 Hz to 2469 Hz. This option is incompatible with the following options:

- H701 - Individual Call
- H702 - Two-Tone Group Call

H167 - Timed Auto Reset

To select this option you must select the Quik Call II option. This option allows you to enter the time after which the radio goes back to Quik Call decode mode (i.e., after decoding Quik Call in the Quik Call decode mode). In addition, transmitting while in the Quik Call decode mode resets the timer at the end of the transmission. The valid range is 1 - 290 seconds (a default of 5 seconds is set if this option is selected). This option will be selected automatically if option H188 is selected. If this option is not selected, the radio will be in manual reset mode : you can manually force a reset by momentarily depressing the monitor button.

H188 - Carrier Override Timed Auto Reset

To select this option you must select the Quik Call II option. This option is used in conjunction with option H167 (Timed Auto Reset). You can enter a value ranging from 1 to 290 seconds (a default of 5 seconds is set if this option is selected), in case option H167 is not already selected. If you select this option, the timer is reset at the end of the carrier. This is in addition to the characteristics described for H167.

Singletones - General (PTT/RATs)

This is the most flexible option out of all the three single tone options. When selecting this option ,two windows will pop-up in sequence. Enter a frequency in each of these pop-up windows. Both of these tones can be transmitted through any of the three transmit switches (PTT/RAT1/RAT2). The valid range for these two frequencies is from 300 Hz to 3000 Hz in increments of 1 Hz. This option is a non-numbered option.This option is incompatible with the following options.

- H707 - 1 Tone Singletone via PTT Button
- H742 - 2 Tone Singletones via RAT Buttons

The following options are enabled if you select this option :

- Singletone Non-Std. Pretime
- Singletone Time Duration
- H619 -Omit MDC Side Tones

H707 - 1 Tone Singletone via PTT Button

When selecting this option a pop-up window is displayed and you are asked to enter a frequency for single tone1. If H707 is enabled, RAT1 and RAT2 buttons are disabled and single tone1 is sent out through PTT on all channels. This option is incompatible with all the MDC Unit ID (PTT) options. The valid range for single tone1 is from 300 Hz to 3000 Hz in increments of 1 Hz. This option is incompatible with the following options:

- Singletones - General (PTT/RATs)
- H742 - 2 Tone Singletone via RAT Buttons.
- All the MDC Unit ID (PTT) Options.

The following options are enabled if you select this option :

- Singletone Non-Std. Pretime
- Singletone Time Duration
- H619 -Omit MDC Side Tones

H742 - Up to 2 Singletones via RAT Buttons

This option is very similar to the Singletone - General option. When selecting this option two pop-up windows are displayed on the screen sequentially. Enter a frequency in both the windows. If this option is enabled and none of the MDC Unit ID options are selected then signalling on PTT is disabled. If this option is selected along with any of the MDC Unit ID options then MDC Unit ID is sent out via PTT. Single tone1 is sent out through RAT1 and single tone2 is sent out through RAT2. You may leave the default single tone 2 frequency, in case you need only one single tone. This option is incompatible with the following options:

- Singletone - General (PTT/RATs)
- H707 - 1 Tone Single tone via PTT Button
- Multiple Repeater Access Codes - MDC 600
- Multiple Repeater Access Codes - MDC 1200

The following options are enabled if you select this option :

- Singletone Non-Std. Pretime
- Singletone Time Duration
- H619 -Omit MDC Side Tones

Singletone Non-Std. Pretime

To select this option you must select either Singletones - General or H707 or H742. When selecting this option a pop-up window will be displayed on the screen and you will be asked to enter a pretime value. Pretime is the time for which the unmodulated carrier goes out before sending the signal out to bring up the repeater. The valid range is from 0 to 1000 ms in increments of 10 ms. The default value is set to 40 ms.

Singletone Time Duration

To select this option you must select Singletones - General or H707 or H742. When selecting this option a pop-up window will be displayed on the screen and you will be asked to enter a time duration value. The valid range is 0 to 20,000 ms in increments of 10 ms. If option H707 is selected, the valid range for single tone time duration is from 1 to 20,000 ms in increments of 10 ms. When "0" is entered as single tone time duration, the process of transmitting single tones becomes manual. In manual process you must press PTT for the period of time you want to transmit the singletones. The manual timing and H707 are incompatible. The default value for the time duration is 600 ms, if this option is not selected.

Multiple Repeater Access Codes - MDC 600

Selecting this option allows you to treat the RAT switches as MDC (600) repeater access devices. The radio can have a maximum of 8 track-moded repeater IDs. Each of the RATs can be tied to a single tone or MDC. The MDC IDs for repeater access can be entered in a pop-up window upon selection of this option. The valid range of the IDs is from 0000 - 9999. This option is incompatible with unit ID MDC (PTT) options requiring MDC 1200 (H959/H962/H967/H946), and also with H742.

If you select this option, the following options will be enabled :

- H619 - Omit MDC side Tones
- H770 - MDC Pretime Delay - 300 ms
- H771 - MDC Pretime Delay - 700 ms
- H779 - MDC Non-standard Pretime Delay

Multiple Repeater Access Codes - MDC 1200

Selecting this option allows you to treat the RAT switches as MDC (1200) repeater access devices. The radio can have a maximum of 8 track-moded repeater IDs. Each of the RATs can be tied to a single tone or MDC. The MDC IDs for repeater access can be entered in a pop-up window upon selection of this option. The valid range of the IDs is from 0000 - 9999. This option is incompatible with unit ID MDC (PTT) options requiring MDC-1200 (H958/H961/H963/H923), and also with H742.

If you select this option, the following options will be enabled :

- H619 - Omit MDC side Tones
- H770 - MDC Pretime Delay - 300 ms
- H771 - MDC Pretime Delay - 700 ms
- H779 - MDC Non-standard Pretime Delay

H549 - 8D Master Option (Advanced STATALERT)

Selecting this option will give you access to MDC Decode Features that are available to Saber radios possessing a Pass 8D Core and using MDC-1200 signalling. Options incompatible with this feature are Quik Call, Single Tone and any MDC-600 feature. Some Pass 6D options are also common to the Pass 8D radio. These include: Zero Audio Enable, Timed Auto Reset, Auto Reset Carrier Override.

If you select this option, the following options will be enabled:

- Zero Audio Enable
- Remote Monitor
- MDC-1200 Call Alert
- MDC-1200 Individual Selective Call
- MDC-1200 Group Selective Call

Radio Check

This feature allows a dispatcher the means to determine if a radio is on and operational via an RF command. Radio check is automatically enabled for a pass 8D radio and can be used provided a valid MDC unit ID exists in the radio. MDC decode must be enabled on the channel that the radio check command was issued in order to work correctly.

Radio Inhibit

This feature allows a dispatcher the means to render a radio "dead" via an RF command. The radio can be "brought back to life" by issuing a cancel radio inhibit command or by reprogramming the radio with the RSS. Radio inhibit is automatically enabled for a pass 8D radio and can be used provided a valid MDC unit ID exists in the radio. MDC decode must be enabled on the channel that the radio inhibit command was issued in order to work correctly.

Limited Patience Timer (Polite Emergency)

When selecting this option, you will be prompted for a value between 1 and 255 seconds. In between Polite Emergency data pack transmissions, the radio will wait this length of time for the channel to become free. If this timer expires, the Emergency packet is sent out, whether or not the channel is free.

If this option is not selected, the timer will be set to 0 providing “Infinite Patience”.

Remote Monitor

Selecting this option allows the dispatcher to activate the transmit audio circuitry of the radio and monitor audio activity around the radio. Upon receiving a remote monitor command, the radio will key up the transmitter, acknowledge the command, set the PTT unit ID, and activate the microphone. If a second microphone is attached, its audio will be transmitted instead. The transmission will last for the time specified in the argument of the remote monitor command. After the transmission time, the radio dekeys and returns to normal operation.

If the radio is inhibited, transmission following the receipt of a Remote Monitor command will always be silent.

If the radio is processing normal Remote Monitor and the silent bit in the Remote Monitor command is set, the radio will operate silent, without turning the red LED on for transmission and without issuing side tones. Otherwise, sidetones and LED operation will go on just as if the user had pressed the PTT.

If Emergency is enabled and activated while normal Remote Monitor transmission is taking place, the Remote Monitor transmission will be canceled and the radio will enter the normal Emergency Cycle.

Call Alert

Call Alert is a type of paging function initiated by the dispatcher to get the attention of a radio that is not responding to normal activity. Upon receiving the Call Alert from the dispatcher, the target radio will sound a series of Alert tones and display a flashing visual indicator.

MDC Alert Tones

When the MDC Alert Tone option is enabled, incoming MDC Selective Calls are preceded by a series of audible Alert Tones in order to alert the user. The Alert Tones are followed by the voice message. If this option is not selected, no Alert Tones will sound. Only the voice message will be heard.

MDC Individual Selective Call

Selective Call eliminates the annoyance of users having to listen to traffic that has nothing to do with them. Sel Cal is used to “set up” the call with the receiving unit, and to allow announcement type messages to an individual or group units.

Individual Selective Call allows each radio equipped with a decoder to examine the MDC data packet and respond only to calls addressed to them by alerting the user and automatically unmuting the speaker audio. After the transmission is complete, the radio automatically returns to the muted standby state. Users may not respond directly to a Selective Call.

Emergency Acknowledge Retry Timer

Upon selecting this option, you will be prompted to enter a value between 0 and 15 seconds. This value specifies the amount of time that the radio will wait before sending another Emergency data packet when an acknowledgment has not been received from a previous data packet transmission.

DOS Mute Timer

DOS (Data Operated Squelch) is the radio's ability to mute the audio while examining the MDC data packet that precedes many transmissions. This eliminates the miscellaneous noise at the beginning of an incoming transmission that would otherwise be heard.

When selecting this option, you will be prompted for a timer value between 100 and 1500 milliseconds, in 5 millisecond steps. Whenever an MDC data packet is detected by the radio, it will use this timer value to determine how long to wait before unmuting the audio. The default is 95ms greater than the MDC pretime. This is the recommended value.

APPENDIX - 6. Quik-Call II Frequencies and Codes

Table 1: Motorola System

FREQUENCY	CODE	FREQUENCY	CODE	FREQUENCY	CODE
0288.5	138	0562.3	GB	1034.7	131
0296.5	108	0569.1	120	1047.1	NB
0304.7	139	0582.1	HZ	1063.2	162
0312.6	BZ	0584.8	151	1084.0	PZ
0313.0	109	0600.9	121	1092.4	189
0321.7	140	0602.6	HA	1122.1	PA
0330.5	110	0617.4	152	1122.5	190
0339.6	141	0623.7	HB	1153.4	191
0346.7	CZ	0634.5	122	1161.4	PB
0349.0	111	0645.7	JZ	1185.2	192
0358.6	142	0651.9	153	1217.8	193
0358.9	CA	0668.3	JA	1251.4	194
0368.5	112	0669.9	123	1285.8	195
0371.5	CB	0688.3	154	1321.2	196
0378.6	143	0691.8	JB	1357.6	197
0384.6	DZ	0707.3	124	1395.0	198
0389.0	113	0716.1	KZ	1433.4	199
0398.1	DA	0726.8	155	1472.9	170
0399.8	144	0741.3	KA	1513.5	171
0410.8	114	0746.8	125	1550.0	CQ
0412.1	DB	0767.4	156	1555.2	172
0422.1	145	0767.4	KB	1598.0	173
0426.6	EZ	0788.5	126	1642.0	174
0433.7	115	0794.3	LZ	1650.0	DQ
0441.6	EA	0810.2	157	1687.2	175
0445.7	146	0822.2	LA	1733.7	176
0457.1	EB	0832.5	127	1781.5	177
0457.9	116	0851.1	LB	1830.5	178
0470.5	147	0855.5	158	1881.0	179
0473.2	FZ	0879.0	128	1930.2	200
0483.5	117	0881.0	MZ	1989.1	201
0489.8	FA	0903.2	159	2043.8	202
0496.8	148	0912.0	MA	2094.5	203
0507.0	FB	0928.1	129	2155.6	204
0510.5	118	0944.1	MB	2212.2	205
0524.6	149	0953.7	160	2271.7	206
0524.8	GZ	0977.2	NZ	2334.6	207
0539.0	119	0979.9	130	2401.0	208
0543.3	GA	1006.9	161	2468.2	209
0553.9	150	1011.6	NA		

Table 2: General Electric System

FREQUENCY	CODE	FREQUENCY	CODE
457.5	44	832.5	22
472.5	43	847.5	23
487.5	42	862.5	24
502.5	41	877.5	25
517.5	1	892.5	26
532.5	2	907.5	27
547.5	3	922.5	28
562.5	4	937.5	29
577.5	5	952.5	30
592.5	6	967.5	31
607.5	7	982.5	32
622.5	8	997.5	33
637.5	9	1012.5	34
652.5	10	1027.5	35
667.5	11	1042.5	36
682.5	12	1057.5	37
697.5	13	1077.5	38
712.5	14	1087.5	39
727.5	15	1102.5	40
742.5	16	1117.5	45
757.5	17	1132.5	46
772.5	18	1147.5	47
787.5	19	1162.5	48
802.5	20	1177.5	49
817.5	21	1192.5	50
		1207.5	51

Table 3: Plectron System

FREQUENCY	CODE	FREQUENCY	CODE
307.8	P40	871.0	P8
321.4	P41	910.0	P9
335.6	P42	950.0	P10
350.5	P43	992.0	P11
366.0	P44	1036.0	P12
382.3	P45	1082.0	P13
399.2	P46	1130.0	P14
416.9	P47	1180.0	P15
435.3	P48	1232.0	P16
454.6	P49	1287.0	P17
474.8	P50	1344.0	P18
495.8	P51	1403.0	P19
517.8	P52	1465.0	P20
540.7	P53	1530.0	P21
564.7	P54	1598.0	P22
589.7	P55	1669.0	P23
615.8	P56	1743.0	P24
643.0	P1	1820.0	P25
672.0	P2	1901.0	P26
701.0	P3	1985.0	P27
732.0	P4	2073.0	P28
765.0	P5	2164.0	P29
799.0	P6	2260.0	P30
834.0	P7	2361.0	P31
		2465.0	P32

Table 4: Federal System

FREQUENCY	CODE
643.0	F1
692.0	F2
749.0	F3
810.0	F4
877.0	F5
949.0	F6
1026.0	F7
1110.0	F8
1201.0	F9
1299.0	F10
1405.0	F11
1520.0	F12
1695.0	F13
1780.0	F14
1926.0	F15
2084.0	F16
2255.0	F17
2440.0	F18

APPENDIX - 7. SQUELCH CODES

PRIVATE LINE (PL) CODES AND THEIR CORRESPONDING FREQUENCIES (in Hz)

XZ	-	67.0	ZZ	-	91.5	3Z	-	123.0	6Z	-	167.9	M4	-	225.7
WZ	-	69.3	ZA	-	94.8	3A	-	127.3	6A	-	173.8	9Z	-	229.1
XA	-	71.9	ZB	-	97.4	3B	-	131.8	6B	-	179.9	M5	-	233.6
WA	-	74.4	1Z	-	100.0	4Z	-	136.5	7Z	-	186.2	M6	-	241.8
XB	-	77.0	1A	-	103.5	4A	-	141.3	7A	-	192.8	M7	-	250.3
WB	-	79.7	1B	-	107.2	4B	-	146.2	M1	-	203.5	OZ	-	254.1
YZ	-	82.5	2Z	-	110.9	5Z	-	151.4	8Z	-	210.7			
YB	-	88.5	2B	-	118.8	5B	-	162.2	M3	-	218.1			

DIGITAL PRIVATE LINE (DPL) CODES

023	025	026	031	032	043	047	051	054	065	071	072
073	074	114	115	116	125	131	132	134	143	152	155
156	162	165	172	174	205	223	226	243	244	245	251
261	263	265	271	306	311	315	331	343	346	351	364
365	371	411	412	413	423	431	432	445	464	465	466
503	506	516	532	546	565	606	612	624	627	631	632
654	662	664	703	712	723	731	732	734	743	754	

GLOSSARY

- ARCHIVE:** To save a copy of the radio codeplug data, either by printing it or saving it on magnetic media.
- ARROW KEYS:** The cursor movement keys located on the numeric keypad (UP = #8, DOWN = #2, LEFT = #4, RIGHT = #6). For the Radio Service Software application, the LEFT and RIGHT arrow keys are used to move the cursor within a data entry field. The UP and DOWN arrow keys are used to increment and decrement values.
- ASCII:** An acronym for American Standard Code for Information Interchange. It is a seven-bit code that defines 128 standard characters, including control characters, letters, numbers, and symbols.
- ASYNCHRONOUS** A method of data communications in which information is transmitted one COMMUNICATIONS character at a time. A start bit precedes each character and a stop bit follows it.
- BACKUP:** A duplicate copy of a computer file that you save on another floppy disk, in case the original file is corrupted, damaged, or accidentally erased.
- BOOT:** To load the computer's operating system.
- BUS SIGNALLING:** The protocol used in communication between elements of a system, either within a unit or between units. This usually refers to a definable methodology which may or may not be proprietary to MOTOROLA. Serial Bus Signalling is typically used to interface a RIB to a radio for the purpose of altering a radio's codeplug or changing service parameters.
- CARRIER SQUELCH:** A radio receive mode of operation that unmutes the receiver only in the presence of a received signal.
- CHANNEL:** A pair of receive and transmit frequencies.
- CODEPLUG:** Data stored in solid state media, ie. ROM's, PROM's, EPROM's, and EEPROM's. Codeplug data is normally accessed via executable code running from firmware.
- COM 1 & COM 2:** The logical names of the two serial ports available on IBM PC computers (if the computer is so equipped.)
- CSQ:** Abbreviation for Carrier Squelch. See definition for Carrier Squelch.

CURSOR:	The flashing marker used to indicate the current position on the display screen.
DATABASE:	An organized file containing records on related data.
DATA ENTRY:	Formatted display with highlighted fields for entering codeplug
SCREEN:	parameter (data). A prompt for the type of required user action, either data selection from a list or direct keyboard entry, is indicated in the top right section of the screen.
DECREMENT:	To decrease a value.
DEFAULTS:	Standard data or parameter values.
DEFAULT DRIVE:	The disk drive that the Radio Service Software will use to GET data from or SAVE data to. You can change the default drive from the PROGRAMMER CONFIGURATION menu.
DE-KEY:	Turn the transmitter off (release push-to-talk).
DIRECTORY:	A catalog of files on a disk. To view the catalog of files on a disk on drive A:, enter the DOS Directory command: DIR A: [Enter]
DISK DRIVE:	The device that reads and programs information on a permanent storage medium; ie. floppy disks or hard disks.
DISKETTE:	An alterable permanent magnetic storage medium for microcomputers. Also called a disk, floppy disk, or mini diskette.
¹ DOS:	An acronym for Disk Operating System. DOS is a group of programs that control the way the computer interfaces with other programs, tells the computer how to use, read, and return information to and from application programs, and how to organize and use the information on disks.
² DOS:	DOS or Data Operated Squelch, is the radios ability to mute the audio while examining the MDC data packet that precedes many transmissions. This eliminates the miscellaneous noise at the beginning of an incoming transmission that would otherwise be heard.
DPL:	An acronym for Digital Private Line. A channel that has DPL on the receive frequency will require both the presence of carrier as well as the correct DPL code before it will unmute. Also, if you have DPL on the transmit frequency, all transmissions on that channel will be modulated at a sub-audible level with the DPL code. Modulation will be continuous.
DRIVE:	See disk drive.
DTMF:	An acronym for Dual Tone Multi-frequency. DTMF is a signalling system used by the Bell Telephone System.
DVP:	An acronym for Digital Voice Protection. DVP is one of several encryption algorithms.

EEPROM:	An acronym for Electrically Erasable Programmable Read Only Memory. EEPROM's are used for radio codeplugs as a permanent storage medium for radio alignment data and customer-specific parameters. The Radio Service Software permits changing and/or viewing of EEPROM information.
ENTER:	A synonym for the RETURN key.
EPROM:	An acronym for Electrically Programmable Read Only Memory. A EPROM, an electrical device, is used as a permanent storage medium for the software program that controls the radio. EPROM information cannot be changed once it is programmed into the device, i.e. 'Read Only'.
ERROR:	Any condition that prevents the software from functioning properly or any input/response that deviates from what the software was designed to accept.
EXIT:	To leave the current displayed screen and return to the previous screen. The Radio Service Software uses the F10 function key for all exit operations.
FIELD:	Any data parameter on the computer display. The current selected field is always highlighted via inverse video.
FILE:	A collection of information typically stored by the computer on a magnetic medium.
FIRMWARE:	Executable code stored in solid state media, ie. ROM's, PROM's, and EPROM's.
FUNCTION KEYS:	The 10 keys at the left or top of the keyboard labeled F1 - F10. The Radio Service Software uses these keys for moving up and down the program tree.
HARD DISK:	An alterable permanent data storage medium with a much larger storage capacity than a diskette. Typically a microcomputer hard disk can store 20 - 50 million pieces of data, compared to approximately 400 - 1000 thousand pieces for a floppy disk.
HARDWARE:	Physical kits of PC boards, solid state devices, interconnect cabling that you can touch and see.
HELP:	An on-line reference manual accessed via the F1 function key. Press the F1 function key at any time for additional information about the current menu or highlighted data field.
INCREMENT:	To increase a value.
INVERSE VIDEO:	Displaying text on the monitor by using dark letters on a light background.

MEMORY:	Electronic devices (RAM's) used by the computer for temporarily storing information that can be extracted when needed. The information is lost when the computer is turned off. The Radio Service Software requires a minimum of 512K bytes of available RAM (memory).
MENU:	A display screen with a list of choices, via the function keys. All keyboard keys are disabled on menu screens.
MENU DRIVEN:	A type of computer application that allows the user to select a course of action based upon one or more options. The Radio Service Software uses function keys for menu selections.
MODE:	A pre-programmed combination of either a conventional transmit and receive frequency pair, an associated squelch code pair, and timeout timer value or a trunking talk group and associated personality assignment.
MODEM:	An acronym for modulator/demodulator. A device that enables a computer to communicate with another computer over the telephone lines.
MONITOR:	The video screen of your computer. The monitor and the keyboard are used by the operator to communicate with another computer over the telephone lines.
OPERATING:	The set of instructions that coordinates your microcomputers SYSTEM: activities, such as memory allocation, file management, input and output operations, communications, and interfacing to other application software packages, such as the Radio Service Software.
PARAMETER:	Codeplug data --information that performs a control.
PATH:	The description of the relationship of a sub-directory to the ROOT directory of the disk. For example take the path "C:\SABER\ARCHIVE". This path states that a program operating out of the ROOT directory C: must look through the sub-directory SABER to find a file in the sub-directory ARCHIVE.
PC:	An acronym for Personal Computer.
PERSONALITY:	A trunking term used to describe the combination of a system assignment and a set of permitted features and options. A trunking mode is uniquely determined by the personality assignment and the talk group ID.
PL:	Abbreviation of Private Line. A channel that has PL on the receive frequency will require both the presence of carrier as well as the correct PL code before it will unmute. Also, if you have PL on the transmit frequency, all transmissions on that channel will be modulated at a sub-audible level with the PL code. Modulation will be continuous.

PORT:	An electrical connection on a computer used to communicate with other devices, such as a radio, modem, or a printer.
PROGRAM:	<p>1) A set of computer instructions designed to have the computer perform a specific sequence of actions.</p> <p>2) The transfer of information from the computer's temporary memory (RAM) to the radio codeplug.</p>
PROGRAM TREE:	A figurative term used to describe the organization of a multi-level menu-driven software program.
PTT:	An acronym for Push to Talk. The PTT button is a control on the side of the radio that lets you transmit.
Quik-Call II:	A receive-only function similar to paging.
RAM:	An acronym for Random Access Memory. RAM's are electrical devices used for temporary storage of computer or radio information.
RAT1:	An acronym for Repeater Access Tone 1. The RAT1 is a control (on the side of the radio) that lets you access a repeater.
RAT2:	An acronym for Repeater Access Tone 2. The RAT2 is a control (on the side of the radio) that lets you access a repeater.
READ:	The transfer of information from the radio codeplug to the computer's temporary memory (RAM) via the RIB communication link.
RIB:	An acronym for Radio Interface Box. The RIB is used to connect to a computer system to a radio for the purpose of communicating between the radio and the computer. The RIB consists mainly of level-shifting circuits that convert from the standard RS-232 voltage levels of the computer asynchronous serial interface to the single-ended voltage levels present on the Serial Bus contacts of the radio's feature connector. In conjunction with the RIB, an appropriate RIB-to-radio cable and RIB-to-computer cable must be used.
RPF:	An acronym for Radio Personality File. RPF is a file saved onto disk as a data file.
RS232:	An asynchronous, serial, data transmission standard that defines the required sequence, timing, and hardware interface.
SAVE:	The transfer of information from the computer's temporary memory (RAM) to a permanent storage medium (disk).
SOFTWARE:	A set of instructions that tells the computer what to do.

- SYSTEM:** A trunking term used to define a specific repeater site via an ID, and individual ID, the control channel frequencies, the connect tones, failsoft information, and a set of permitted features and options.
- SUB-DIRECTORY:** A subdivision of a directory that contains a group of related files. Sub-directories are used to organize your disks, especially hard disks, and to facilitate good housekeeping.
- TOT:** An acronym for Time out Timer. The TOT function limits the transmission period to a pre-defined time. The radio will automatically stop transmitting when the timer goes off after the pre-defined time and will generate an alert tone to notify you that no transmission is taking place.
- TPL:** Abbreviation of Tone Private Line Squelch. The Private Line Squelch that uses sub-audible tones to unmute the receiver.
- TREE:** A way to describe the organization of the Service Software. The MASTER menu is considered the trunk and the functions listed on the menu are considered branches.

INDEX

A	Page
About This Guide.....	1
Access and Hangup Codes, Manual Interconnect	61
Access and Hangup Codes, Auto Dial	60
Acronyms and Abbreviations	iv
Align Channel Menu (Fig. 11).....	30
Align Channel Parameters	30
Align Radio Menu 1 (Fig. 10a).....	22
Align Radio Menu 2 (Fig. 10b).....	22
Align Radio Parameters	22
Align Scan Controls.....	33
Align Scan Menu (Fig. 12).....	33
Alignment Procedure, Test Setup for (Fig. 8)	20
Audio Processing	26
Auto Dial/Access and Hangup Codes	60
Autodial Setup Screen (Fig. 29)	60
B	
Battery Save Enable.....	33
Battery Save Squelch	25
Battery Threshold	25
C	
Change/Create/View Codeplug Menu (Fig. 19).....	45
Change/Create/View Radio Personality	45
Channel Information	54
Channel Information Screen (Fig. 27)	54
Channel Parameters	30
Computer Software Copyrights.....	Inside Front Cover
Codeplug Data	37
Configuration, PC (Fig. 6).....	16
Configure Screen Colors (Fig. 7).....	17
Configuration, Software	15
Connecting Radio to Computer	10
Connecting Radio to Computer (Fig. 4).....	10
Create Radio Personality File.....	46
Create RPF Menu (Fig. 20)	46
Create/Modify Scan Lists Screen (Fig. 31).....	62
Create/Modify Selectable PL Codes (Fig. 32)	64
Customer Support	2
D	
Delete Functions	43
Disk, How to Format (Appendix 3)	70
DTMF Dial Delay	27
DTMF Tone OFF Time.....	27
DTMF Tone ON Time	27
Dual-Floppy Disk Drive System.....	12

<u>E</u>	<u>Page</u>
Error Messages (Appendix 1).....	67
Extraction of Radio Alignment Data (Fig. 16).....	41
<u>F</u>	
Federal System (Table 4).....	88
Foreword.....	Inside Front Cover
Format Scan Lists.....	62
Format Selectable PL.....	64
Frequencies and Codes, Quik-Call II (Appendix 6).....	83
Functions Performed.....	1
<u>G</u>	
General Electric System (Table 2).....	84
Get/Save/Program Menu (Fig. 13).....	37
Get/Save/Program Codeplug Data from/to Disk/Codeplug.....	37
Getting Started.....	3
Glossary.....	90
<u>H</u>	
Hard Disk Installation Procedure.....	13
Hardware Installation.....	9
Hardware, Optional Requirements.....	10
HELP Screen.....	19
Host Computer and Options Required.....	9
How This Manual is Organized.....	3
How The Screens are Organized.....	3
<u>I</u>	
Installing Software.....	12
Dual-Floppy Disk Drive System.....	12
Hard Disk Installation Procedure.....	13
Introduction.....	1
<u>K</u>	
Keyboard Commands (Appendix 2).....	69
Keyboard, How to Use.....	6
<u>L</u>	
List of Figures.....	iii
List of Tables.....	iii
Load/Save/Delete Functions.....	43
Load/Save/Delete Menu (Fig. 17).....	43
Low Battery Threshold.....	25

<u>M</u>	<u>Page</u>
MAIN Menu	7
MAIN Menu (Fig. 3)	7
Manual, How Organized	3
Manual Interconnect Access and Hangup Codes	61
Manual Telephone Interconnect Screen (Fig. 30)	61
Messages, Error (Appendix 1)	67
Microphone Gain	29
Models, SABER (Appendix 4)	71
Motorola System (Table 1)	83
Multiple Repeater Access Codes Screen (Fig. 26)	53
<u>O</u>	
Optional Hardware Requirements	10
Options List and Definitions (Appendix 5)	72
Options, Radio Feature	48
Options Required, Host Computer	9
Options Screen (Fig. 21)	48
Oscillator Warp	23
<u>P</u>	
PC Configuration (Fig. 6)	16
Personality, Radio	46
PL, Selectable	63
Plectron System (Table 3)	87
Power Level	24
Print Menu (Fig. 33)	65
Print Radio Personality	65
<u>Q</u>	
Quik-Call II Frequencies and Codes (Appendix 6)	83
Quik-Call II System Selection Screen (Fig. 22)	51
Quik-Call II H701 Parameters Screen (Fig. 23)	52
Quik-Call II H702 Parameters Screen (Fig. 24)	52
Quik-Call II H703 Parameters Screen (Fig. 25)	53
<u>R</u>	
Radio Alignment Data, Extraction of (Fig. 16)	41
Radio Feature Options	48
Radio Parameters	22
Radio Personality, Change/Create/View	45
Radio Personality, Print	65
Radio Personality File, Create	46
Radio Service Software Program Tree (Fig. 1)	4
Radio, Servicing	20
Radio, How to Set Up	20
Read Function	38
Read Radio Display (Fig. 14)	38
Reference Modulation Alignment, VCO and	32
RPF Display, Save (Fig. 17)	43
RPF Menu, Create (Fig. 20)	46

<u>S</u>	<u>Page</u>
Save Function	42
Save RPF Display (Fig. 17)	43
Scan Controls, Align	33
Scan Lists	62
Scan Monitor Hold Time	34
Scan Priority Squelch	36
Scan Receive Response Time	35
Scan Transmit Response Time	35
Screen Color, Configure (Fig. 7)	17
Screen Display Format (Fig. 2)	5
Screens, Organization of	3
Screens, How to Read	5
Secure Deviation Offset	27
Service/Alignment Menu (Fig. 9)	21
Servicing the Radio	20
Setup Computer Configuration (Fig. 5)	15
Sidetone Volume	26
Software, How to Configure	15
Software Installation	12
Squelch	31
System, Federal (Table 4)	88
System, General Electric (Table 2)	84
System, Motorola (Table 1)	83
System, Plectron (Table 3)	87
 <u>T</u>	
Test Setup for Alignment Procedure (Fig. 8)	20
 <u>V</u>	
VCO and Reference Modulation Alignment	32
View Radio Information (Fig. 19)	45
 <u>W</u>	
Warp, Oscillator	23
Wide View Screen (Fig. 28)	58
Write Data to Radio (Fig. 16)	40
Write Function	39

