

Professional Digital Two-Way Radio System

# MOTOTRBO™ XPR™ 6500 / XPR™ 6550

## Display Portable

User Guide





## Declaration of Conformity

This declaration is applicable to your radio **only** if your radio is labeled with the FCC logo shown below.

### DECLARATION OF CONFORMITY

Per FCC CFR 47 Part 2 Section 2.1077(a)



Responsible Party  
Name: Motorola, Inc.

Address: 1301 East Algonquin Road, Schaumburg, IL 60196-1078, U.S.A.  
Phone Number: 1-888-567-7347

Hereby declares that the product:

Model Name: **XPR 6500/XPR 6550**

conforms to the following regulations:

FCC Part 15, subpart B, section 15.107(a), 15.107(d) and section 15.109(a)

#### **Class B Digital Device**

As a personal computer peripheral, this device complies with Part 15 of the FCC Rules. Operation is subject to the following two conditions:

1. This device may not cause harmful interference, and
2. This device must accept any interference received, including interference that may cause undesired operation.

**Note:** This equipment has been tested and found to comply with the limits for a Class B digital device, pursuant to part 15 of the FCC Rules. These limits are designed to provide reasonable protection against harmful interference in a residential installation. This equipment generates, uses and can radiate radio frequency energy and, if not installed and used in accordance with the instructions, may cause harmful interference to radio communications. However, there is no guarantee that interference will not occur in a particular installation.

If this equipment does cause harmful interference to radio or television reception, which can be determined by turning the equipment off and on, the user is encouraged to try to correct the interference by one or more of the following measures:

- Reorient or relocate the receiving antenna.
- Increase the separation between the equipment and receiver.
- Connect the equipment into an outlet on a circuit different from that to which the receiver is connected.
- Consult the dealer or an experienced radio/TV technician for help.

# Contents

This User Guide contains all the information you need to use the MOTOTRBO XPR Series Digital Portable Radios.

- Declaration of Conformity** ..... i
- Important Safety Information** ..... vii
  - Product Safety and RF Exposure Compliance ..... vii
- Software Version** ..... vii
- Computer Software Copyrights** ..... viii
- Getting Started** ..... 1
  - How to Use This Guide ..... 1
  - What Your Dealer/System Administrator Can Tell You ..... 1
- Preparing Your Radio for Use** ..... 2
  - Charging the Battery ..... 2
  - Attaching the Battery ..... 2
  - Attaching the Antenna ..... 3
  - Attaching the Belt Clip ..... 3

- Attaching the Universal Connector Cover ..... 3
- Powering Up the Radio ..... 4
- Adjusting the Volume ..... 4
- Identifying Radio Controls** ..... 5
  - Radio Controls You Will Be Using ..... 5
  - Programmable Buttons ..... 6
    - Assignable Radio Functions ..... 6
    - Assignable Settings or Utility Functions ..... 7
  - Accessing the Programmed Functions ..... 7
  - Using the Keypad ..... 8
  - Push-To-Talk (PTT) Button ..... 9
  - Switching Between Analog and Digital Mode ..... 9
- Identifying Status Indicators** ..... 10
  - Display Icons ..... 10
  - Call Icons ..... 11
  - Sent Item Icons ..... 11
  - LED Indicator ..... 12
  - Audio Tones ..... 12

<b>Making and Receiving Calls</b> .....	<b>13</b>	Monitoring Features .....	20
Selecting a Zone .....	13	Monitoring a Channel .....	20
Selecting a Radio Channel, Subscriber ID, or Group ID .....	13	Permanent Monitor .....	20
Receiving and Responding to a Radio Call .....	14	<b>Advanced Features</b> .....	<b>21</b>
Receiving and Responding to a Group Call .....	14	Radio Check .....	21
Receiving and Responding to a Private Call .....	15	Sending a Radio Check .....	21
Receiving an All Call .....	16	Remote Monitor .....	23
Making a Radio Call .....	16	Initiating Remote Monitor .....	23
Making a Call with the Channel Selector Knob .....	17	Scan Lists .....	24
Making a Group Call .....	17	Viewing an Entry in the Scan List .....	24
Making a Private Call .....	17	Editing the Scan List .....	25
Making an All Call .....	18	Adding a New Entry to the Scan List .....	25
Making a Group or Private Call with the One Touch Call Button .....	18	Deleting an Entry from the Scan List .....	25
Talkaround .....	19	Setting and Editing Priority for an Entry in the Scan List .....	26
		Scan .....	26
		Starting and Stopping Scan .....	27
		Responding to a Transmission During a Scan .....	27

Deleting a Nuisance Channel .....	28	Making a Call Alert from the Contacts List .....	36
Restoring a Nuisance Channel .....	28	Making a Call Alert with the One Touch	
Contacts Settings .....	28	Call Button .....	36
Making a Group Call from Contacts .....	29	Emergency Operation .....	37
Making a Private Call from Contacts .....	29	Receiving an Emergency Alarm .....	37
Making a Private Call by Alias Search .....	30	Responding to an Emergency Alarm .....	38
Call Indicator Settings .....	31	Sending an Emergency Alarm .....	38
Activating and Deactivating Call Ringers		Sending an Emergency Alarm with Call .....	39
for Private Calls .....	31	Sending an Emergency Alarm with	
Activating and Deactivating Call Ringers		Voice to Follow .....	39
for Text Message .....	32	Reinitiating an Emergency Mode .....	40
Assigning Ring Styles .....	32	Exiting Emergency Mode .....	40
Escalating Alarm Tone Volume .....	33	Text Message Features .....	41
Call Log Features .....	33	Writing and Sending a Text Message .....	41
Viewing Recent Calls .....	33	Sending a Quick Text Message .....	42
Missed Call Screen .....	34	Sending a Quick Text Message with the	
Storing an Alias or ID from the Missed		One Touch Call Button .....	42
Call List .....	34	Managing Fail-to-Send Text Messages .....	43
Deleting a Call from a Call List .....	35	Resending a Text Message .....	43
Call Alert Operation .....	35	Forwarding a Text Message .....	43
Receiving and Acknowledging a Call Alert .....	35	Editing a Text Message .....	44

Managing Sent Text Messages .....	44	Controlling the Display Backlight .....	55
Viewing a Sent Text Message .....	45	Turning the Radio Tones/Alerts On	
Sending a Sent Text Message .....	45	or Off .....	56
Deleting All Sent Text Messages		Turning the Talk Permit Tone On or Off .....	56
from Sent Items .....	46	Turning the LED Indicator On or Off .....	57
Receiving a Text Message .....	47	Turning the Introduction Screen On	
Reading a Text Message .....	47	or Off .....	57
Managing Received Text Messages .....	47	Accessing General Radio Information .....	58
Viewing a Text Message from the Inbox .....	48	Accessing the Battery Information .....	58
Replying to a Text Message from		Checking the Radio ID .....	59
the Inbox .....	48	Checking the Firmware Version .....	59
Deleting a Text Message from the Inbox .....	49	Checking the Codeplug Version .....	59
Deleting All Text Messages from		<b>Accessories .....</b>	<b>60</b>
the Inbox .....	49	Antennas .....	60
Privacy .....	50	Batteries .....	61
Dual Tone Multi Frequency (DTMF) .....	51	Carry Devices .....	61
Security .....	51	Chargers .....	62
Radio Disable .....	51	Earbuds and Earpieces .....	62
Radio Enable .....	52	Headsets and Headset Accessories .....	62
Utilities .....	53	Remote Speaker Microphones .....	63
Locking and Unlocking the Keypad .....	53	Surveillance Accessories .....	63
Turning Keypad Tones On or Off .....	54	Miscellaneous Accessories .....	64
Setting the Squelch Level .....	54	<b>Batteries and Chargers Warranty .....</b>	<b>65</b>
Setting the Power Level .....	54	<b>Limited Warranty .....</b>	<b>66</b>
Turning the Option Board Feature(s)			
On or Off .....	55		



## Important Safety Information

### Product Safety and RF Exposure Compliance



Caution

Before using this product, read the operating instructions for safe usage contained in the Product Safety and RF Exposure booklet enclosed with your radio.

### ATTENTION!

**This radio is restricted to occupational use only to satisfy FCC RF energy exposure requirements.**

Before using this product, read the RF energy awareness information and operating instructions in the Product Safety and RF Exposure booklet enclosed with your radio (Motorola Publication part number 6881095C98) to ensure compliance with RF energy exposure limits.

For a list of Motorola-approved antennas, batteries, and other accessories, visit the following website:

<http://www.motorola.com/governmentandenterprise>

## Software Version

All the features described in the following sections are supported by the radio's software version **R01.02.01**.

See ***Checking the Firmware Version*** on page 59 to determine your radio's software version.

Please check with your dealer or system administrator for more details of all the features supported.

## Computer Software Copyrights

The Motorola products described in this manual may include copyrighted Motorola computer programs stored in semiconductor memories or other media. Laws in the United States and other countries preserve for Motorola certain exclusive rights for copyrighted computer programs including, but not limited to, the exclusive right to copy or reproduce in any form the copyrighted computer program. Accordingly, any copyrighted Motorola computer programs contained in the Motorola products described in this manual may not be copied, reproduced, modified, reverse-engineered, or distributed in any manner without the express written permission of Motorola. Furthermore, the purchase of Motorola products shall not be deemed to grant either directly or by implication, estoppel, or otherwise, any license under the copyrights, patents or patent applications of Motorola, except for the normal non-exclusive license to use that arises by operation of law in the sale of a product.

The AMBE+2™ voice coding Technology embodied in this product is protected by intellectual property rights including patent rights, copyrights and trade secrets of Digital Voice Systems, Inc.

This voice coding Technology is licensed solely for use within this Communications Equipment. The user of this Technology is explicitly prohibited from attempting to decompile, reverse engineer, or disassemble the Object Code, or in any other way convert the Object Code into a human-readable form.

U.S. Pat. Nos. #5,870,405, #5,826,222, #5,754,974, #5,701,390, #5,715,365, #5,649,050, #5,630,011, #5,581,656, #5,517,511, #5,491,772, #5,247,579, #5,226,084 and #5,195,166.

---

## Getting Started

Take a moment to review the following:

How to Use This Guide . . . . . page 1

What Your Dealer/System Administrator Can Tell You . . page 1

### ■ How to Use This Guide

---

This User Guide covers the basic operation of the MOTOTRBO Portables.

However, your dealer or system administrator may have customized your radio for your specific needs. Check with your dealer or system administrator for more information.

Throughout this publication, two icons are used to differentiate Analog mode and Digital mode only features:



Indicates an Analog Mode only feature.



Indicates a Digital Mode only feature.

For features that are available in both Analog and Digital modes, no icon is shown.

### ■ What Your Dealer/System Administrator Can Tell You

---

You can consult your dealer or system administrator about the following:

- Is your radio programmed with any preset conventional channels?
- Which buttons have been programmed to access other features?
- What optional accessories may suit your needs?

## Preparing Your Radio for Use

Assemble your radio by following these steps:

Charging the Battery . . . . .	page 2
Attaching the Battery . . . . .	page 2
Attaching the Antenna . . . . .	page 3
Attaching the Belt Clip . . . . .	page 3
Attaching the Universal Connector Cover . . . . .	page 3
Powering Up the Radio . . . . .	page 4
Adjusting the Volume . . . . .	page 4

### ■ Charging the Battery

Your radio is powered by a Nickel Metal-Hydrate (NiMH) or Lithium-Ion (Li-Ion) battery. To avoid damage and comply with warranty terms, charge the battery using a Motorola charger *exactly* as described in the charger user guide.

Charge a new battery 14 to 16 hours before initial use for best performance.

**IMPORTANT:** **ALWAYS** charge your IMPRES battery with the IMPRES charger. Using a conventional charger causes irrecoverable loss of IMPRES battery data. As a result, the battery functions as a non-IMPRES battery and cannot display the data on your radio. Additionally, it voids your IMPRES battery warranty, although the standard battery warranty still applies.

### ■ Attaching the Battery

Align the battery with the rails on the back of the radio. Press the battery firmly, and slide upward until the latch snaps into place. Slide battery latch into lock position.

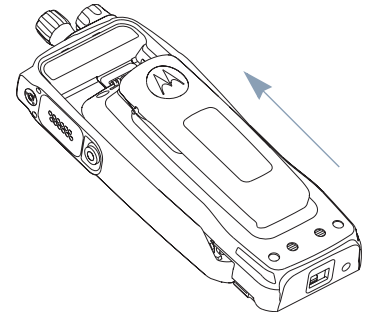

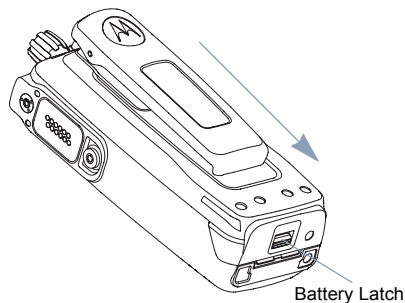

To remove the battery, turn the radio off. Move the battery latch into unlock position and hold, and slide the battery down and off the rails.

## ■ Attaching the Belt Clip

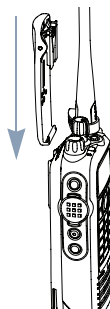

Align the grooves on the clip with those on the battery and press downward until you hear a click.

To remove the clip, press the belt clip tab away from the battery using a key. Then slide the clip upward and away from the radio.

## ■ Attaching the Antenna

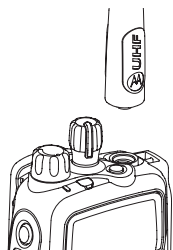

With the radio turned off, set the antenna in its receptacle and turn clockwise.

To remove the antenna, turn the antenna counterclockwise. Make sure you turn off the radio and remove the universal connector cover first.



Caution

If antenna needs to be replaced, ensure that only MOTOTRBO antennas are used. Neglecting this will damage your radio. See **Antennas** on page 60 for a list of available antennas.

## ■ Attaching the Universal Connector Cover

The universal connector is located on the antenna side of the radio. It is used to connect MOTOTRBO accessories to the radio.

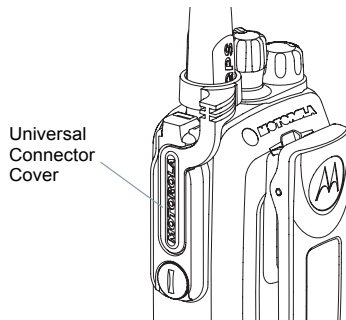

Place the universal connector cover loop over the attached antenna. Slide it all the way down to the base of the antenna.

Insert the hooked end of the cover into the slots above the universal connector.

Press downward on the cover to seat the lower tab properly into the RF connector.

Turn the thumbscrew clockwise to secure the connector cover to the radio.

*To remove the universal connector cover, press down on the cover and turn the thumbscrew counterclockwise. Lift the cover up, slide the connector cover loop upwards, and remove it from the attached antenna.*

## ■ Powering Up the Radio

Rotate the **On/Off/Volume Control Knob** clockwise until you hear a click. You see Motorola and MOTOTRBO (TM) on the radio's display momentarily, followed by Motorola once more.

The LED blinks green and the Home screen lights up if the backlight setting is set to turn on automatically.

**NOTE:** The Home screen does not light up during a power up if the LED indicator is disabled (see **Turning the LED Indicator On or Off** on page 57).

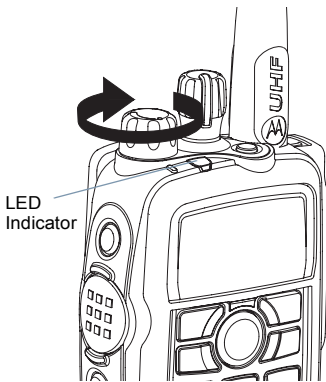

A brief tone sounds, indicating that the power up test is successful.

**NOTE:** There is no power up tone if the radio tones/alerts function is disabled (see **Turning the Radio Tones/ Alerts On or Off** on page 56).

If your radio does not power up, check your battery. Make sure that it is charged and properly attached. If your radio still does not power up, contact your dealer.

*To turn off the radio, rotate this knob counterclockwise until you hear a click. You see a brief *Powering Down* on the radio's display.*

## ■ Adjusting the Volume

To increase the volume, turn the **On/Off/Volume Control Knob** clockwise.

*To decrease the volume, turn this knob counterclockwise.*

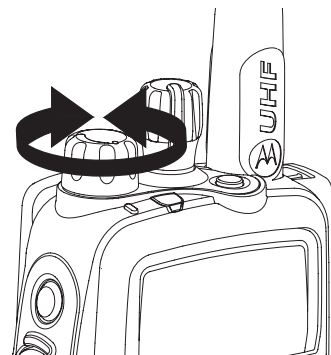

## Identifying Radio Controls

Take a moment to review the following:

Radio Controls You Will Be Using . . . . .	page 5
Programmable Buttons . . . . .	page 6
Accessing the Programmed Functions . . . . .	page 7
Using the Keypad . . . . .	page 8
Push-To-Talk (PTT) Button . . . . .	page 9
Switching Between Analog and Digital Mode . . . . .	page 9

### ■ Radio Controls You Will Be Using

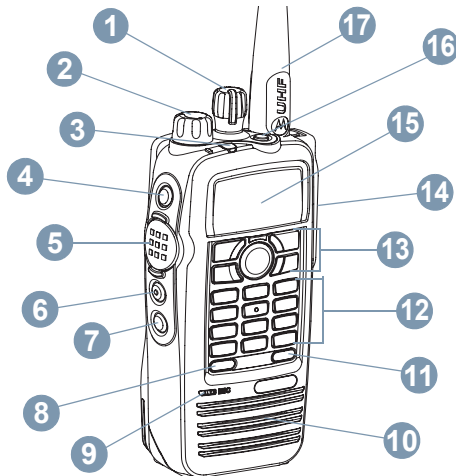

- 1 Channel Selector Knob
- 2 On/Off/Volume Control Knob
- 3 LED Indicator
- 4 Side Button 1\*
- 5 Push-to-Talk (PTT) Button
- 6 Side Button 2\*
- 7 Side Button 3\*
- 8 Front Button P1\*
- 9 Microphone
- 10 Speaker
- 11 Front Button P2\*
- 12 Keypad
- 13 Menu Navigation Keys
- 14 Universal Connector for Accessories
- 15 Display
- 16 Emergency Button\*
- 17 Antenna

\* These buttons are programmable.

## ■ Programmable Buttons

Your dealer can program the programmable buttons as shortcuts to radio functions or preset channels/groups depending on the duration of a button press:

- Press – Pressing and releasing rapidly.
- Long press – Pressing and holding for the programmed duration (between 0.25 seconds and 3.75 seconds).
- Hold down – Keeping the button pressed.

### 📄 Assignable Radio Functions

**Contacts** – Provides direct access to the Contacts list.

**Emergency** – Depending on the programming, initiates or cancels an emergency alarm or call.

**Manual Dial**  – Initiates a call by keying in any subscriber ID.

**Monitor** – Monitors a selected channel for activity.

**Nuisance Channel Delete** – Temporarily removes an unwanted channel, except for the Selected Channel, from the scan list. The Selected Channel refers to the user's selected zone/channel combination from which scan is initiated.

**One Touch Call**  – Directly initiates a predefined Private or Group Call, a Call Alert or a Quick Text message.

**Option Board Feature** – Toggles option board feature(s) on or off for option board-enabled channels.

**Permanent Monitor** – Monitors a selected channel for all radio traffic until function is disabled.

**Privacy**  – Toggles privacy on or off.

**Radio Check**  – Determines if a radio is active in a system.

**Radio Enable**  – Allows a target radio to be remotely enabled.

**Radio Disable**  – Allows a target radio to be remotely disabled.

**Remote Monitor**  – Turns on the microphone of a target radio without it giving any indicators.

**Repeater/Talkaround** – Toggles between using a repeater and communicating directly with another radio.

**Scan** – Toggles scan on or off.

**Telemetry Control**  – Controls the Output Pin on a local or remote radio.

**Text Message**  – Selects the text message menu.

**Zone** – Allows selection from a list of zones.



## 📄 Assignable Settings or Utility Functions

**All Tones/Alerts** – Toggles all tones and alerts on or off.

**Backlight** – Toggles display backlight on or off.

**Keypad Lock** – Toggles keypad between locked and unlocked.

**Power Level** – Toggles transmit power level between high and low.

**Squelch** 📡 – Toggles squelch level between tight and normal.

## ■ Accessing the Programmed Functions







You can access various radio functions through one of the following ways:

- A short or long press of the relevant programmable buttons.



OR

- Use the Menu Navigation Buttons as follows:

- 1 To access the menu, press the  button. Press the appropriate **Menu Scroll** button ( or ) to access the menu functions.
- 2 To select a function or enter a sub-menu, press the  button.
- 3 To go back one menu level, or to return to the previous screen, press the  button. Long press the  button to return to the Home screen.

**NOTE:** Your radio automatically exits the menu after a period of inactivity and returns to your Home screen.

## ■ Using the Keypad

You can use the 3 x 4 alphanumeric keypad to access your radio's features. You can use the keypad to enter subscriber aliases or IDs, and text messages. Many characters require that you press a key multiple times. The table below shows the number of times a key needs to be pressed to generate the required character.

Key	Number of Times Key is Pressed												
	1	2	3	4	5	6	7	8	9	10	11	12	13
<b>1</b> .?	1	.	,	?	!	@	&	'	%	-	:	*	#
<b>2</b> abc	A	B	C	2									
<b>3</b> def	D	E	F	3									
<b>4</b> ghi	G	H	I	4									
<b>5</b> jkl	J	K	L	5									
<b>6</b> mno	M	N	O	6									
<b>7</b> pqrs	P	Q	R	S	7								
<b>8</b> tuv	T	U	V	8									
<b>9</b> wxyz	W	X	Y	Z	9								
<b>0</b> CAPS	0	<b>NOTE:</b> Press to enter "0" and long press to activate the CAPS lock. Another long press to turn off the CAPS lock.											
<b>* DEL</b>	* or del	<b>NOTE:</b> Press during text entry to delete the character. Press during numeric entry to enter a "*" .											
<b>#</b> —	# or space	<b>NOTE:</b> Press during text entry to insert a space. Press during numeric entry to enter a "#".											

## ■ Push-To-Talk (PTT) Button

The **PTT** button on the side of the radio serves two basic purposes:

- While a call is in progress, the **PTT** button allows the radio to transmit to other radios in the call.

Press and hold down **PTT** button to talk. Release the **PTT** button to listen.

The microphone is activated when the **PTT** button is pressed.

- While a call is not in progress, the **PTT** button is used to make a new call (see **Making a Radio Call** on page 16).

*If the Talk Permit Tone is enabled (see **Turning the Talk Permit Tone On or Off** on page 56), wait until the short alert tone ends before talking.*

- 🔊 *During a call, if the Channel Free Indication feature is enabled on your radio (programmed by your dealer), you will hear a short alert tone the moment the target radio (the radio that is receiving your call) releases the **PTT** button, indicating the channel is free for you to respond.*

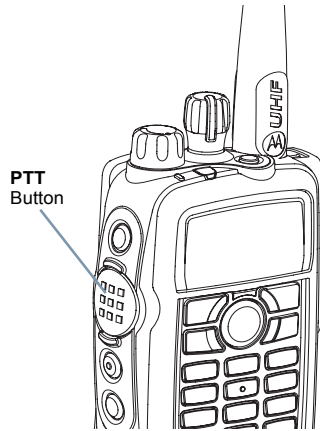

*You will also hear the Channel Free Indication tone if your call is interrupted, for example when the radio receives an Emergency Call.*

*You can turn off the Channel Free Indication tone by disabling all radio tones and alerts (see **Turning the Radio Tones/Alerts On or Off** on page 56).*

## ■ Switching Between Analog and Digital Mode

Each channel in your radio can be configured as an analog channel or a digital channel. Use the Channel Selector Knob to switch between an analog or a digital channel.

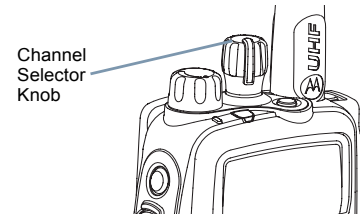

When switching from digital to analog mode, certain features are unavailable. Icons for the digital features (such as Messages) reflect this change by appearing “grayed out”. Disabled features are hidden in the menu.

Your radio also has features available in both analog and digital mode. However, the minor differences in the way each feature works does **NOT** affect the performance of your radio.

**NOTE:** Your radio also switches between digital and analog modes during a dual mode scan (see **Scan** on page 26).

## Identifying Status Indicators



Your radio indicates its operational status through the following:

Display Icons . . . . .	page 10
Call Icons . . . . .	page 11
Sent Item Icons . . . . .	page 11
LED Indicator . . . . .	page 12
Audio Tones . . . . .	page 12

### ■ Display Icons

The full dot matrix, black and white, liquid crystal display (LCD) of your radio shows radio status, text entries, and menu entries.

The following are icons that appear on the radio's display.

-  **Received Signal Strength Indicator (RSSI)**  
The number of bars displayed represents the radio signal strength. Four bars indicate the strongest signal. This icon is only displayed while receiving.
-  **Monitor**  
Selected channel is being monitored.
- Power Level**  
Radio is set at Low power.
-  **Power Level**  
Radio is set at High power.



#### **Tones Disable**

Tones are turned off.



#### **Option Board**

The Option Board is enabled.



#### **Option Board Non-Function**

The Option Board is disabled.



#### **GPS Available**

The GPS feature is enabled. The icon stays lit when a position fix is available.



#### **GPS Not Available/Out of Range**

The GPS feature is enabled but is not receiving data from the satellite.



#### **Scan**

Scan feature is enabled.



#### **Priority Scan**

Radio detects activity on channel/group designated as Priority 1 (if • is blinking) or Priority 2 (if • is steady).



#### **Unread Message**

User has unread message(s) in the Inbox.



#### **Inbox Full**

User's Inbox is full.

**Emergency**

Radio is in Emergency mode.

**Privacy**

The Privacy feature is enabled.

**Talkaround**

In the absence of a repeater, radio is currently configured for direct radio to radio communication.

**Battery**

The number of bars (0 – 4) shown indicates the charge remaining in the battery.  
Blinks when the battery is low.

## ■ Call Icons

---

The following icons appear on the radio's display during a call. These icons also appear in the Contacts list to indicate ID type.

**Private Call**

Indicates a Private Call in progress. In the Contacts list, it indicates a subscriber alias (name) or ID (number).

**Group Call/All Call**

Indicates a Group Call or All Call in progress. In the Contacts list, it indicates a group alias (name) or ID (number).

## ■ Sent Item Icons

---

The following icons appear at the top right corner of the radio's display in the Sent Items folder.

**Sent Successfully**

The text message is sent successfully.

**Send Failed**

The text message cannot be sent.

**In-Progress**

- The text message to a group alias or ID is pending transmission.
- The text message to a subscriber alias or ID is pending transmission, followed by waiting for acknowledgement.

## ■ LED Indicator

The LED indicator shows the operational status of your radio.

**Blinking red** – Radio is transmitting at low battery condition, receiving an emergency transmission or has failed the self-test upon powering up.

**Solid yellow** – Radio is monitoring a channel.

**Blinking yellow** – Radio is scanning for activity or receiving a Call Alert.

**Solid green** – Radio is transmitting.

**Blinking green** – Radio is powering up, receiving a non-privacy-enabled call or data, or detecting activity over the air.

**Rapidly blinking green** – Radio is receiving a privacy-enabled call or data. 

**NOTE:** When the LED blinks green, it indicates the radio detects activity over the air. Due to the nature of the digital protocol, this activity may or may not affect the radio's programmed channel.

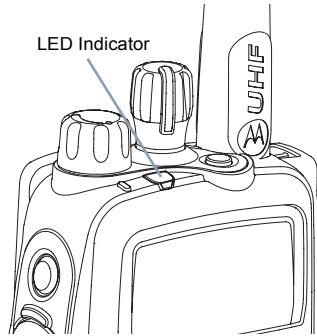

Upon a PTT button press, if the radio is programmed for polite operation, the radio automatically determines whether a transmission is permitted via a Talk Permit or a Talk Denial tone.

## ■ Audio Tones

Alert tones provide you with audible indications of the radio's status or the radio's response to data received.

**Continuous Tone** A monotone sound. Sounds continuously until termination.



**Periodic Tone** Sounds periodically depending on the duration set by the radio. Tone starts, stops, and repeats itself.



**Repetitive Tone** A single tone that repeats itself until it is terminated by the user.



**Momentary Tone** Sounds only once for a short period of time defined by the radio.



## Making and Receiving Calls

Once you understand how your MOTOTRBO Portable is configured, you are ready to use your radio.

Use this navigation guide to familiarize yourself with the basic Call features:

Selecting a Zone . . . . .	page 13
Selecting a Radio Channel, Subscriber ID, or Group ID . . . . .	page 14
Receiving and Responding to a Radio Call . . . . .	page 14
Making a Radio Call . . . . .	page 16
Talkaround . . . . .	page 19
Monitoring Features . . . . .	page 20

### ■ Selecting a Zone

A zone is a group of channels. Your radio supports up to a maximum of 50 zones.

Use the following procedure to select a zone.







**Procedure:**

Press the programmed Zone button and proceed to step 3.

**OR**

Follow the procedure below.

- 1  to access the menu.

- 2  or  to Zone and press  to select.
- 3 The current zone is displayed and indicated by a ✓.
- 4  or  to the required zone and press  to select.
- 5 The display shows <Zone> Selected momentarily and returns to the selected zone screen.

### ■ Selecting a Radio Channel, Subscriber ID, or Group ID

**Procedure:**

Once the required zone is displayed (if you have multiple zones in your radio), turn the programmed Channel Selector Knob to select the channel, subscriber alias or ID, or group alias or ID.

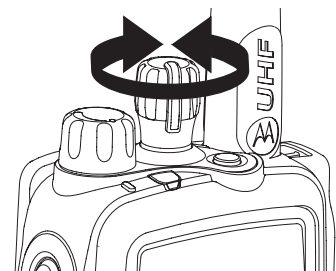

## ■ Receiving and Responding to a Radio Call

Once the channel, subscriber ID or group ID is displayed, you can proceed to receive and respond to calls.

*The LED lights up solid green while the radio is transmitting and blinks green when the radio is receiving.*

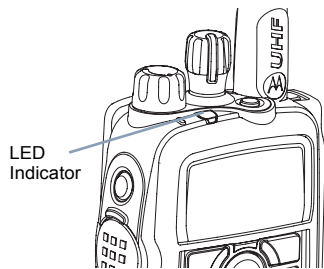

**NOTE:** The LED lights up solid green while the radio is transmitting and blinks green rapidly when the radio is receiving a privacy-enabled call.

To unscramble a privacy-enabled call, your radio must have the same Privacy Key (programmed by your dealer) as the transmitting radio (the radio you are receiving the call from). See **Privacy** on page 50 for more information. 

## 📄 Receiving and Responding to a Group Call

To receive a call from a group of users, your radio must be configured as part of that group.

### Procedure:

When you receive a Group Call (while on the Home screen):

- 1 The LED blinks green.

---

- 2 The first line of the display shows the caller alias, and the RSSI icon. The second line displays the group alias and the Group Call icon (in Digital mode only).

---

- 3 Hold the radio vertically 1 to 2 inches (2.5 to 5.0 cm) from your mouth.
  -  If the Channel Free Indication feature is enabled, you will hear a short alert tone the moment the transmitting radio releases the **PTT** button, indicating the channel is free for you to respond.

---

- 4 Press the **PTT** button to respond to the call. The LED lights up solid green.

---



- 5 Wait for the Talk Permit Tone to finish (if enabled) and speak clearly into the microphone.
- 6 Release the **PTT** button to listen.
- 7 If there is no voice activity for a predetermined period of time, the call ends.

See **Making a Group Call** on page 17 for details on making a Group Call.

**NOTE:** If the radio receives a Group Call while not on the Home screen, it remains on its current screen prior to answering the call.

Long press the  button to go to the Home screen to view the caller alias before replying.

## Receiving and Responding to a Private Call

A Private Call is a call from an individual radio to another individual radio.

There are two types of Private Calls. The first type, where a radio presence check is performed prior to setting up the call, while the other sets up the call immediately.

When your radio is checked, the LED blinks green.

Only one of these call types can be programmed to your radio by your dealer.

### Procedure:

When you receive a Private Call:

- 1 The LED blinks green.
- 2 The first line of the display shows the subscriber alias or ID, and the RSSI icon. The second line displays Private Call and the Private Call icon.
- 3 Hold the radio vertically 1 to 2 inches (2.5 to 5.0 cm) from your mouth. If the Channel Free Indication feature is enabled, you will hear a short alert tone the moment the transmitting radio releases the **PTT** button, indicating the channel is free for you to respond.
- 4 Press the **PTT** button to respond to the call. The LED lights up solid green.
- 5 Wait for the Talk Permit Tone to finish (if enabled) and speak clearly into the microphone.
- 6 Release the **PTT** button to listen.
- 7 If there is no voice activity for a predetermined period of time, the call ends.
- 8 You hear a short tone. The display shows Call Ended.

See **Making a Private Call** on page 17 for details on making a Private Call.

## Receiving an All Call

An All Call is a call from an individual radio to every radio on the channel. It is used to make important announcements requiring the user's full attention.

### Procedure:

When you receive an All Call:

- 1 A tone sounds and the LED blinks green.
- 2 The first line of the display shows the caller alias, and the RSSI icon. The second line displays All Call and the All Call icon.
- 3 Once the All Call ends, the radio returns to the previous screen before receiving the call.
  -  If the Channel Free Indication feature is enabled, you will hear a short alert tone the moment the transmitting radio releases the **PTT** button, indicating the channel is now available for use.

*You cannot respond to an All Call.*



See **Making an All Call** on page 18 for details on making an All Call.

**NOTE:** The radio stops receiving the All Call if you switch to a different channel while receiving the call. During an All Call, you will **not** be able to use any programmed button functions until the call ends.

## ■ Making a Radio Call

---

You can select a channel, subscriber ID, or group by using:

- The Channel Selector Knob
- A programmed **One Touch Call** button 
- The Contacts list (see **Contacts Settings** on page 28)
- Manual Dial (via Contacts) – This method is for Private Calls only and is dialed using the keypad (see **Making a Private Call from Contacts** on page 29) 

**NOTE:** Your radio must have the Privacy feature enabled on the channel to send a privacy-enabled transmission. Only target radios with the same Privacy Key as your radio will be able to unscramble the transmission. See **Privacy** on page 50 for more information. 

## Making a Call with the Channel Selector Knob

### Making a Group Call

To make a call to a group of users, your radio must be configured as part of that group.

#### Procedure:

- 1 Turn the Channel Selector Knob to select the channel with the active group alias or ID.

---

- 2 Hold the radio vertically 1 to 2 inches (2.5 to 5.0 cm) from your mouth.

---

- 3 Press the **PTT** button to make the call. The LED lights up solid green. The display shows the group alias or ID, and the Group Call icon.

---

- 4 Wait for the Talk Permit Tone to finish (if enabled) and speak clearly into the microphone.

---

- 5 Release the **PTT** button to listen. When the target radio responds, the LED blinks green. You see the Group Call icon, the group alias or ID, and transmitting radio alias or ID on your display.

---

- 6 If the Channel Free Indication feature is enabled, you will hear a short alert tone the moment the target radio releases the **PTT** button, indicating the channel is free for you to respond. Press the **PTT** button to respond. 

#### OR

If there is no voice activity for a predetermined period of time, the call ends.

- 7 Radio returns to the previous screen you were on prior to receiving the call.

---

*You can also make a Group Call via Contacts (see **Making a Group Call from Contacts** on page 29).*

### Making a Private Call

#### Procedure:

- 1 Turn the Channel Selector Knob to select the channel with the active subscriber alias or ID.

---

- 2 Hold the radio vertically 1 to 2 inches (2.5 to 5.0 cm) from your mouth.

---

- 3 Press the **PTT** button to make the call. The LED lights up solid green. The first line displays the subscriber alias or ID. The second line displays `Private Call` and the Private Call icon.

---

- 4 Wait for the Talk Permit Tone to finish (if enabled) and speak clearly into the microphone.

---

- 5 Release the **PTT** button to listen. When the target radio responds, the LED blinks green.

---

- 6 If the Channel Free Indication feature is enabled, you will hear a short alert tone the moment the target radio releases the **PTT** button, indicating the channel is free for you to respond. Press the **PTT** button to respond.  
**OR**  
If there is no voice activity for a predetermined period of time, the call ends.

---

- 7 You hear a short tone. The display shows `Call Ended`.

You can also make a Private Call via Contacts (see **Making a Private Call from Contacts** on page 29) or perform a quick alphanumeric search for the required alias via a keypad entry (see **Making a Private Call by Alias Search** on page 30).

### **Making an All Call**

This feature allows you to transmit to all users on the channel. Your radio must be programmed to allow you to use this feature.

#### **Procedure:**

- 1 Turn the Channel Selector Knob to select the channel with the active All Call group alias or ID.

---

- 2 Hold the radio vertically 1 to 2 inches (2.5 to 5.0 cm) from your mouth.

---

- 3 Press the **PTT** button to make the call. The LED lights up solid green. The display shows the All Call group alias or ID, and the All Call icon.

---

- 4 Wait for the Talk Permit Tone to finish (if enabled) and speak clearly into the microphone.

*Users on the channel cannot respond to an All Call.*

### **Making a Group or Private Call with the One Touch Call Button**

The One Touch Call feature allows you to make a Group or Private Call to a predefined alias or ID easily. This feature can be assigned to a short or long programmable button press.

You can **ONLY** have one alias or ID assigned to a **One Touch Call** button. Your radio can have multiple **One Touch Call** buttons programmed.

**Procedure:**

- 1 Press the programmed **One Touch Call** button to make a Group or Private Call to the predefined alias or ID.
  - 2 Hold the radio vertically 1 to 2 inches (2.5 to 5.0 cm) from your mouth.
  - 3 Press the **PTT** button to make the call. The LED lights up solid green. The display shows the group/subscriber alias or ID, and the Group/Private Call icon.
  - 4 Wait for the Talk Permit Tone to finish (if enabled) and speak clearly into the microphone.
  - 5 Release the **PTT** button to listen. When the target radio responds, the LED blinks green.
  - 6 If the Channel Free Indication feature is enabled, you will hear a short alert tone the moment the target radio releases the **PTT** button, indicating the channel is free for you to respond. Press the **PTT** button to respond.
- OR**  
If there is no voice activity for a predetermined period of time, the call ends.
- 7 Radio returns to the screen you were on prior to receiving the call.

*For a Private Call, you hear a short tone when the call ends.*

## ■ Talkaround

---











You can continue to communicate when your repeater is not operating, or when your radio is out of the repeater's range but within talking range of other radios. This is called "talkaround".

**Procedure:**

Press the programmed **Repeater/Talkaround** button to toggle between talkaround and repeater modes.

**OR**

Follow the procedure below.

- 1  to access the menu.
  - 2  or  to Utilities and press  to select.
  - 3  or  to Radio Settings and press  to select.
  - 4  or  to Talkaround and press  to select.
  - 5 You see Turn On if the radio is currently in Repeater mode.
- OR**  
You see Turn Off if the radio is currently in Talkaround mode.
- 6 press  to select.
  - 7 The display shows Talkaround On.
- OR**  
The display shows Talkaround Off.
- 8 The screen automatically returns to the previous menu.

*The Talkaround setting is retained even after powering down.*

## ■ Monitoring Features

---

### Monitoring a Channel

Use the Monitor feature to make sure a channel is clear before transmitting.

#### **Procedure:**

- 1 Press and hold the programmed **Monitor** button and listen for activity. The monitor icon appears on the display.
- 2 You hear radio activity or total silence, depending on how your radio is programmed.
- 3 When you hear “white noise” (that is, the channel is free), press the **PTT** button to talk and release it to listen. The LED lights up solid yellow.

### Permanent Monitor

Use the Permanent Monitor feature to continuously monitor a selected channel for activity.

#### **Procedure:**

- 1 Press the programmed **Permanent Monitor** button.
- 2 Radio sounds an alert tone, the LED lights up solid yellow, and the display shows `Permanent Monitor On`. The monitor icon appears on the display.
- 3 Press the programmed **Permanent Monitor** button to exit Permanent Monitor mode.
- 4 Radio sounds an alert tone, the LED turns off, and display shows `Permanent Monitor Off`.

## Advanced Features

Use this navigation guide to learn more about advanced features available with your radio:

Radio Check . . . . .	page 21
Remote Monitor . . . . .	page 23
Scan Lists . . . . .	page 24
Scan . . . . .	page 26
Contacts Settings . . . . .	page 28
Call Indicator Settings . . . . .	page 31
Call Log Features . . . . .	page 33
Call Alert Operation . . . . .	page 35
Emergency Operation . . . . .	page 37
Text Message Features . . . . .	page 41
Privacy . . . . .	page 50
Security . . . . .	page 51
Utilities . . . . .	page 53

## Radio Check



If enabled, this feature allows you to determine if another radio is active in a system without disturbing the user of that radio. No audible or visual notification is shown on the target radio.

This feature is only applicable for subscriber aliases or IDs.

### Sending a Radio Check

#### Procedure:

Using the programmed **Radio Check** button.

- 1 Press the programmed **Radio Check** button.
- 2  or  to the required subscriber alias or ID and press  to select.
- 3 The display shows `Radio Check: <Subscriber Alias or ID>`, indicating that Radio Check is in progress. The LED lights up solid green.
- 4 Wait for acknowledgement.
- 5 If the target radio is active in the system, a tone sounds and the display briefly shows `Target Radio Available`.  
**OR**  
If the target radio is not active in the system, a tone sounds and the display briefly shows `Target Radio Not Available`.

6 Radio returns to the subscriber alias or ID screen.

---



**OR**

**Procedure:**



Using the menu.

1  to access the menu.



---

2  or  to **Contacts** and press  to select.

---





3  or  to the required subscriber alias or ID and press  to select.

**OR**

 or  to **Manual Dial** and press  to select.

If there was previously dialed ID, the ID appears along with a blinking cursor. Use the keypad to edit the ID. Press  to select.

**OR**

 or  to **Manual Dial** and press  to select. Key in the subscriber alias or ID and press .

---

4  or  to **Radio Check** and press  to select.

---

5 The display shows **Radio Check: <Subscriber Alias or ID>**, indicating that Radio Check is in progress. The LED lights up solid green.

---

6 Wait for acknowledgement.

---

7 If the target radio is active in the system, a tone sounds and the display briefly shows **Target Radio Available**.

**OR**

If the target radio is not active in the system, a tone sounds and the display briefly shows **Target Radio Not Available**.

---

8 Radio returns to the subscriber alias or ID screen.

---

*If the  button is pressed when the radio is waiting for acknowledgement, a tone sounds, and the radio terminates all retries and exits Radio Check mode.*



## ■ Remote Monitor

Use the Remote Monitor feature to turn on the microphone of a target radio (subscriber alias or IDs only). No audible or visual indication is given to the target radio. You can use this feature to monitor, remotely, any audible activity surrounding the target radio.

Your radio must be programmed to allow you to use this feature.



### Initiating Remote Monitor

#### Procedure:

Using the programmed **Remote Monitor** button.

- 1 Press the programmed **Remote Monitor** button.

---

- 2  or  to the required subscriber alias or ID and press  to select.

---

- 3 Radio sounds an alert tone and the LED blinks green.

---

- 4 Wait for acknowledgment.

---

- 5 The display shows `Remote Monitor Successful`.  
**OR**  
 The display shows `Remote Monitor Failed`.

- 6 If successful:  
 The radio starts receiving audio from the monitored radio for a programmed duration.  
 Once the timer expires, the radio sounds an alert tone and the LED turns off. The display shows `Remote Monitor Ended`.  
**OR**  
 If unsuccessful:  
 The radio repeats the attempt until the programmed number of tries expires.



#### OR

#### Procedure:











Using the menu.



- 1  to access the menu.

---

- 2  or  to `Contacts` and press  to select.

---

- 3  or  to the required subscriber alias or ID and press  to select.  
**OR**  
 or  to `Manual Dial` and press  to select.  
 If there was previously dialed ID, the ID appears along with a blinking cursor. Use the keypad to edit the ID. Press  to select.  
**OR**  
 or  to `Manual Dial` and press  to select. Key in the subscriber alias or ID and press  to select.

- 4  or  to Remote Mon. and press  to select.

---

- 5 Radio sounds an alert tone and the LED blinks green.

---

- 6 Wait for acknowledgment.

---

- 7 The display shows Remote Monitor Successful.  
**OR**  
The display shows Remote Monitor Failed.

---

- 8 If successful:  
The radio starts receiving audio from the monitored radio for a programmed duration.  
Once the timer expires, the radio sounds an alert tone and the LED turns off. The display shows Remote Monitor Ended.  
**OR**  
If unsuccessful:  
The radio repeats the attempt until the programmed number of tries expires.

---

## ■ Scan Lists

---

Scan lists are created and assigned to individual channels/groups. Your radio scans for voice activity by cycling through the channel/group sequence specified in the scan list for the current channel/group.

Your radio can support up to 32 scan lists, with a maximum of 16 members in a list. Each scan list supports a mixture of both analog and digital entries.



You can add, delete, or prioritize channels by editing a scan list.

### Viewing an Entry in the Scan List



#### Procedure:

- 1  to access the menu.



---

- 2  or  to Scan and press  to select.

---

- 3  or  to View/Edit List and press  to select.

---

- 4 Use  or  to view each member on the list.

---

*The priority icon appears left of the member's alias, if set, to indicate whether the member is on a Priority 1 or Priority 2 channel list. You **cannot** have multiple Priority 1 or Priority 2 channels in a scan list.*

*There is no priority icon if priority is set to **None**.*



## Editing the Scan List

### Adding a New Entry to the Scan List



#### Procedure:

- 1  to access the menu.



---

  - 2  or  to Scan and press  to select.



---

  - 3  or  to View/Edit List and press  to select.



---

  - 4  or  to Add Member and press  to select.

---

  - 5  or  to the required alias or ID and press  to select.







---

  - 6  or  to the required priority level and press  to select.

---

  - 7 The display shows Entry Saved, followed immediately by Add Another?.

---



  - 8  or  to Yes and press  to select, to add another entry, and repeat steps 5 and 6.
- OR**
-  or  to No and press  to select to save the current list.

## Deleting an Entry from the Scan List



#### Procedure:

- 1  to access the menu.



---

  - 2  or  to Scan and press  to select.



---

  - 3  or  to View/Edit List and press  to select.







---

  - 4  or  to the required alias or ID and press  to select.

---

  - 5  or  to Delete and press  to select.

















---

  - 6 At Delete Entry?,  or  to Yes and press  to select, to delete the entry. The display shows Entry Deleted.
- OR**
-  or  to No and press  to select to return to the previous screen.
- 
- 7 Repeat steps 4 to 6 to delete other entries.

*After deleting all required aliases or IDs, long press  to return to the Home screen.*

## Setting and Editing Priority for an Entry in the Scan List

### Procedure:

- 1  to access the menu.
- 2  or  to Scan and press  to select.
- 3  or  to View/Edit List and press  to select.
- 4  or  to the required alias or ID and press  to select.
- 5  or  to Edit Priority and press  to select.
- 6  or  to the required priority level and press  to select.
- 7 The display shows Entry Saved before returning to the previous screen.
- 8 The priority icon appears left of the member's name.

*There is no priority icon if priority is set to **None**.*

## ■ Scan

---

When you start a scan, your radio cycles through the programmed scan list for the current channel looking for voice activity.

The LED blinks yellow and you see the scan icon on the display.

During a dual mode scan, if you are on a digital channel, and your radio locks onto an analog channel, it automatically switches from digital mode to analog mode for the duration of the call. This is also true for the reverse.

There are two ways of initiating scan:

- **Main Channel Scan (Manual):** Your radio scans all the channels/groups in your scan list. On entering scan, your radio may – depending on the settings – automatically start on the last scanned “active” channel/group or on the channel where scan was initiated.
- **Auto Scan (Automatic):** Your radio automatically starts scanning when you select a channel/group that has Auto Scan enabled.

## Starting and Stopping Scan

### Procedure:

Press the programmed **Scan** button to start or stop Scan.

### OR



Follow the procedure below.

- 1 Use the Channel Selector Knob to select a channel programmed with a scan list.

---

- 2  to access the menu.

---

- 3  or  to Scan and press  to select.

---

- 4 The display shows Turn On if scan is disabled.  
**OR**  
The display shows Turn Off if scan is enabled.

---

- 5 Press  to select.

---

- 6 The LED blinks yellow and the scan icon is displayed when Scan is enabled.  
**OR**  
The LED turns off and the scan icon is not displayed when Scan is disabled.

---

*While scanning, the radio will only accept data (e.g. text message, location, telemetry, or PC data) if received on its Selected Channel.*

## Responding to a Transmission During a Scan

During scanning, your radio stops on a channel/group where activity is detected. The radio stays on that channel for a programmed time period known as “hang time”.

### Procedure:

- 1 Hold the radio vertically 1 to 2 inches (2.5 to 5.0 cm) from your mouth.  
 If the Channel Free Indication feature is enabled, you will hear a short alert tone the moment the transmitting radio releases the **PTT** button, indicating the channel is free for you to respond.

---

- 2 Press the **PTT** button during hang time. The LED lights up solid green.

---

- 3 Wait for the Talk Permit Tone to finish (if enabled) and speak clearly into the microphone.

---

- 4 Release the **PTT** button to listen.

---

- 5 If you do not respond within the hang time, the radio returns to scanning other channels/groups.

---

## Deleting a Nuisance Channel

If a channel continually generates unwanted calls or noise (termed a “nuisance” channel), you can temporarily remove the unwanted channel from the scan list.

This capability does not apply to the channel designated as the Selected Channel.

### Procedure:

- 1 When your radio “locks on to” an unwanted or nuisance channel, press the programmed **Nuisance Channel Delete** button until you hear a tone.
- 2 Release the **Nuisance Channel Delete** button. The nuisance channel is deleted.

*Deleting a “nuisance” channel is **only** possible through the programmed **Nuisance Channel Delete** button. This feature is **not** accessible through the menu.*

## Restoring a Nuisance Channel

### Procedure:

To restore the deleted nuisance channel, do **one** of the following:

- Power the radio off and then powering it on again, **OR**
- Stop and restart a scan via the programmed **Scan** button or menu, **OR**
- Change the channel via the Channel Selector Knob.

## ■ Contacts Settings

---

Contacts provides “address-book” capabilities on your radio. Each entry corresponds to an alias or ID that you use to initiate a call.

Additionally, each entry, depending on context, associates with **one** of five types of calls: Group Call, Private Call, All Call, PC Call or Dispatch Call.

PC Call and Dispatch Call are data-related. They are only available with the applications. Refer to the data applications documentation for more information.

**NOTE:** If the Privacy feature is enabled on a channel, you can make privacy-enabled Group Call, Private Call, and All Call on that channel. Only target radios with the same Privacy Key as your radio will be able to unscramble the transmission. See **Privacy** on page 50 for more information. 

Your radio supports two Contacts lists, one for Analog contacts (with a maximum of 128 members) and one for Digital contacts (with a maximum of 256 members).

Each entry within Contacts displays the following information:

- Call Type
- Call Alias
- Call ID

**NOTE:** You can add, delete, or edit subscriber IDs for the Digital Contacts list.



For the Analog Contacts list, you can only view the list and initiate a Call Alert. Adding, deleting, and editing capabilities can only be performed by your dealer.

## Making a Group Call from Contacts



### Procedure:

- 1  to access the menu.

---

- 2  or  to **Contacts** and press  to select. The entries are alphabetically sorted.

---

- 3  or  to the required group alias or ID.

---

- 4 Hold the radio vertically 1 to 2 inches (2.5 to 5.0 cm) from your mouth.

---

- 5 Press the **PTT** button to make the call. The LED lights up solid green. The display shows the group alias or ID, and the Group Call icon.

---

- 6 Wait for the Talk Permit Tone to finish (if enabled) and speak clearly into the microphone.

---

- 7 Release the **PTT** button to listen. When any user in the group responds, the LED blinks green. You see the Group Call icon, the group ID, and that user's ID on your display.

---

- 8 If the Channel Free Indication feature is enabled, you will hear a short alert tone the moment the target radio releases the **PTT** button, indicating the channel is free for you to respond. Press the **PTT** button to respond. 

### OR



If there is no voice activity for a programmed period of time, the call ends.

## Making a Private Call from Contacts



### Procedure:

- 1  to access the menu.



---

- 2  or  to **Contacts** and press  to select. The entries are alphabetically sorted.



---

- 3  or  to the required subscriber alias or ID.

---

- OR**  
 or  to **Manual Dial** and press  to select. If there was previously dialed subscriber alias or ID, the alias or ID appears along with a blinking cursor. Use the keypad to edit the ID.

---

- OR**  
 or  to **Manual Dial** and press  to select. Use the keypad to enter a new subscriber alias or ID.

---

- 4 Hold the radio vertically 1 to 2 inches (2.5 to 5.0 cm) from your mouth.
- 5 Press the **PTT** button to make the call. The LED lights up solid green. The first line displays the subscriber alias or ID. The second line displays `Private Call` and the Private Call icon.
- 6 Wait for the Talk Permit Tone to finish (if enabled) and speak clearly into the microphone.
- 7 Release the **PTT** button to listen. When the target radio responds, the LED blinks green and the display shows the transmitting user's ID.
- 8 If the Channel Free Indication feature is enabled, you will hear a short alert tone the moment the target radio releases the **PTT** button, indicating the channel is free for you to respond. Press the **PTT** button to respond.

**OR**

If there is no voice activity for a programmed period of time, the call ends.







- 9 You hear a short tone. The display shows `Call Ended`.

### Making a Private Call by Alias Search

You can also use alias or alphanumeric search to retrieve the required subscriber alias.

This feature is only applicable while in Contacts.

**Procedure:**

- 1  to access the menu.
- 2  or  to `Contacts` and press  to select. The entries are alphabetically sorted.
- 3 Key in the first character of the alias.
- 4  or  to the required alias.
- 5 Hold the radio vertically 1 to 2 inches (2.5 to 5.0 cm) from your mouth.
- 6 Press the **PTT** button to make the call. The LED lights up solid green. The first line displays the target radio's ID. The second line displays `Private Call` and the Private Call icon.
- 7 Wait for the Talk Permit Tone to finish (if enabled) and speak clearly into the microphone.
- 8 Release the **PTT** button to listen. When the target radio responds, the LED blinks green.



- 9 If the Channel Free Indication feature is enabled, you will hear a short alert tone the moment the target radio releases the **PTT** button, indicating the channel is free for you to respond. Press the **PTT** button to respond.

**OR**

If there is no voice activity for a programmed period of time, the call ends.

- 10 You hear a short tone. The display shows `Call Ended`.

**NOTE:** If you release the **PTT** button while the radio is setting up the call, it exits without any indication and returns to the previous screen.

Your radio may be programmed to perform a radio presence check prior to setting up the Private Call. If the target radio is not available, you hear a short tone and see `Party Not Available` on the display.

The radio returns to the menu prior to initiating the radio presence check.

## ■ Call Indicator Settings



### 📄 Activating and Deactivating Call Ringers for Private Calls 🎵

You can turn on or off the ringing tones for a received Private Call.



#### Procedure:

- 1  to access the menu.



---

  - 2  or  to `Utilities` and press  to select.



---

  - 3  or  to `Radio Settings` and press  to select.



---

  - 4  or  to `Tones/Alerts` and press  to select.



---

  - 5  or  to `Call Ringers` and press  to select.

---

  - 6  or  to `Private Call` and press  to select.

---

  - 7 The display shows `Turn On`. Press  to enable Call Ringers for Private Calls. The display shows `Private Call Ringer On`.
- OR**
- The display shows `Turn Off`. Press  to disable Call Ringers for Private Calls. The display shows `Private Call Ringer Off`.



## Activating and Deactivating Call Ringers for Text Message

You can turn on or off the ringing tones for a received Text Message.



### Procedure:

- 1  to access the menu.



---

  - 2  or  to Utilities and press  to select.



---

  - 3  or  to Radio Settings and press  to select.



---

  - 4  or  to Tones/Alerts and press  to select.

---

  - 5  or  to Call Ringers and press  to select.







---

  - 6  or  to Text Message and press  to select.

---

  - 7 The current tone is indicated by a ✓.

---

  - 8  or  to the preferred tone and press  to select. The display shows Tone <Number> Selected and a ✓ appears left of the selected tone.
- OR**
-  or  to Turn Off and press  to select. The display shows Text Message Ringer Off and a ✓ appears left of Turn Off.



## Assigning Ring Styles

You can program your radio to sound one of ten predefined ringing tones when receiving a Call Alert or a Text Message from a particular contact.



### Procedure:

- 1  to access the menu.



---

- 2  or  to Contacts and press  to select. The entries are alphabetically sorted.

---

- 3  or  to the required alias or ID and press  to select.



---

- 4  or  to Ring Style and press  to select.

---

- 5 A ✓ indicates the current selected tone.

---

- 6  or  to the required tone and press  to select.

---

- 7 The display shows Contact Saved.

*The radio sounds out each ring style as you navigate through the list.*



## Escalating Alarm Tone Volume

You can program your radio to continually alert you when a radio call remains unanswered. This is done by automatically increasing the alarm tone volume over time. This feature is known as Escalert.



### Procedure:

- 1  to access the menu.



---

- 2  or  to Utilities and press  to select.



---

- 3  or  to Radio Settings and press  to select.



---

- 4  or  to Tones/Alerts and press  to select.

---

- 5  or  to Escalert and press  to select.

---

- 6 The display shows Turn On. Press  to enable Escalert.  
The display shows Escalert On.  
**OR**  
The display shows Turn Off. Press  to disable Escalert.  
The display shows Escalert Off.

---

## ■ Call Log Features

Your radio keeps track of all recent outgoing, answered, and missed Private Calls. Use the call log feature to view and manage recent calls.

You can perform the following tasks in each of your call lists:

- Store ID to Contacts
- Delete



### Viewing Recent Calls

The lists are Missed, Answered, and Outgoing.



### Procedure:

- 1  to access the menu.

---

- 2  or  to Call Log and press  to select.



---

- 3  or  to preferred list and press  to select.

---

- 4 The display shows the most recent entry at the top of the list.

---

- 5  or  to view the list.

---

Press the **PTT** button to start a Private Call with the current selected alias or ID.

## Missed Call Screen

Whenever a call is missed, your radio displays a missed call message. Select **View** to view it immediately or **View Later** to view at a later time.

**NOTE:** The radio exits the Missed Call screen and sets up a Private Call if you press the **PTT** button while viewing a missed call number.

### Procedure:

- 1 The display shows **Missed Calls**, along with the number of calls missed and **View?**.

---

- 2 Press **OK** to view the missed call ID. The missed call log list appears on display.  
Press **OK** to store or delete the entry.  
**OR**  
**◀** or **▶** to **View Later** and press **OK** to select. You return to the Home screen.

---

## Storing an Alias or ID from the Missed Call List

### Procedure:

- 1 **MENU** to access the menu.

---

- 2 **◀** or **▶** to **Call Log** and press **OK** to select.

---

- 3 **◀** or **▶** to **Missed** and press **OK** to select.

---

- 4 **◀** or **▶** to the required missed call alias or ID and press **OK** to select.

---

- 5 **◀** or **▶** to **Store** and press **OK** to select.

---

- 6 A blinking cursor appears. If needed, key in the alias for that ID and press **OK**.

---

- 7 The display shows **Contact Saved**.

---



*You can also store an ID without an alias.*

## Deleting a Call from a Call List



### Procedure:

- 1  to access the menu.



---

- 2  or  to Call Log and press  to select.



---

- 3  or  to the required list and press  to select.



---

- 4  or  to the required alias or ID and press  to select.

---

- 5  or  to Delete Entry? and press  to select.

---

- 6 Press  to select Yes to delete the entry. The display shows Entry Deleted.  
**OR**  
 or  to No to return to the previous screen.

When you select a call list and it contains no entries, the display shows *List Empty*, and sounds a low tone if Keypad Tones are turned on (see **Turning Keypad Tones On or Off** on page 54).

## ■ Call Alert Operation

Call Alert paging enables you to alert a specific radio user to call you back when they are able to do so.

This feature is applicable for subscriber aliases or IDs only and is accessible through the menu via Contacts or manual dial.

### Receiving and Acknowledging a Call Alert

When you receive a Call Alert page, you see Call Alert that alternates with the alias or ID of the calling radio on the display.

#### Procedure:















- 1 You hear a repetitive tone. The LED blinks yellow.

---

- 2 Press and release the **PTT** button to acknowledge the alert.  
**OR**  
 Press  to select Ignore? and to exit the Call Alert.

## Making a Call Alert from the Contacts List

### Procedure:

- 1  to access the menu.
- 2  or  to `Contacts` and press  to select.
- 3  or  to the required subscriber alias or ID and press  to select.  
**OR**  
 or  to `Manual Dial` and press  to select.  
A blinking cursor appears. Enter the subscriber ID you want to page and press .
- 4  or  to `Call Alert` and press  to select.
- 5 The display shows `Call Alert: <Subscriber Alias or ID>`, indicating that the Call Alert has been sent.
- 6 The LED lights up solid green when your radio is sending the Call Alert.
- 7 If the Call Alert acknowledgement is received, a tone sounds and the display shows `Call Alert Successful`.  
**OR**  
If the Call Alert acknowledgement is not received, a tone sounds and the display shows `Call Alert Failed`.

## Making a Call Alert with the One Touch Call Button

### Procedure:

- 1 Press the programmed **One Touch Call** button to make a Call Alert to the predefined alias or ID.
- 2 The display shows `Call Alert: <Subscriber Alias or ID>`, indicating that the Call Alert has been sent.
- 3 The LED lights up solid green when your radio is sending the Call Alert.
- 4 If the Call Alert acknowledgement is received, a tone sounds and the display shows `Call Alert Successful`.  
**OR**  
If the Call Alert acknowledgement is not received, a tone sounds and the display shows `Call Alert Failed`.

## ■ Emergency Operation

An Emergency Alarm is used to indicate a critical situation. You are able to initiate an Emergency at any time on any screen display even when there is activity on the current channel.

Your radio supports 3 Emergency Alarms:

- Emergency Alarm
- Emergency Alarm with Call
- Emergency Alarm with Voice to Follow 

In addition, each alarm has the following types:

- Regular – Radio transmits an alarm signal and shows audio and/or visual indicators.
- Silent – Radio transmits an alarm signal without any audio or visual indicators. There will be no response (call) from the target radio until you press the **PTT** button to initiate the call.
- Silent with Voice – Radio transmits an alarm signal and is able to receive an incoming call, without any audio or visual indicators, until you press the **PTT** button to initiate, or respond to, the call.

Only **one** of the Emergency Alarms above can be assigned to the programmed **Emergency** button.

## Receiving an Emergency Alarm

### Procedure:

- 1 When receiving an Emergency Alarm, the display shows the Emergency icon, the number of alarms received, and **ALARM Rcvd**, which alternates with the alias or ID of the sender.
- 2 A tone sounds and the LED blinks red.
- 3 If enabled, your radio automatically acknowledges the Emergency Alarm.

*When your radio receives an Emergency Alarm, it displays the Emergency Alarm received indications until acknowledgement is sent and you exit the Emergency mode.*

*You will not be able to receive any other indications or displays for any other calls until you exit the Emergency Alarm received screen.*

**NOTE:** Short press , then long press the programmed **Emergency** button to clear the Emergency Alarm received indications and exit Emergency mode.

## Responding to an Emergency Alarm

### Procedure:

When receiving an Emergency Alarm:

- 1 Press any button to stop all Emergency Alarm received indications.

---
- 2 Hold the radio vertically 1 to 2 inches (2.5 to 5.0 cm) from your mouth.  
 If the Channel Free Indication feature is enabled, you will hear a short alert tone the moment the transmitting radio releases the **PTT** button, indicating the channel is now available for use.

---
- 3 Press **PTT** button to initiate a call with the emergency initiating radio. The LED lights up solid green. Your radio remains in the Emergency mode.

---
- 4 Wait for the Talk Permit Tone to finish (if enabled) and speak clearly into the microphone.

---
- 5 Release the **PTT** button to listen. When the emergency initiating radio responds, the LED blinks green. You see the Group Call icon, the group ID, and transmitting radio ID on your display.

---
- 6 Once your call ends, short press , then long press the programmed **Emergency** button to clear the Emergency Call received indications and exit Emergency mode.

---
- 7 The radio returns to the Home screen.

---

## Sending an Emergency Alarm

This feature allows you to send an Emergency Alarm, a non-voice signal, which triggers an alert indication on another radio.

### Procedure:

- 1 Press the programmed **Emergency** button.

---
- 2 The display shows *Sending Alarm*, which alternates with your radio ID. The LED lights up solid green and the Emergency icon appears on the Home screen display.

---
- 3 When an Emergency Alarm acknowledgment is received, the Emergency tone sounds and the LED blinks green. The display shows *Emergency Alarm Successful*.  
**OR**  
If your radio does not receive an Emergency Alarm acknowledgment, and after all retries have been exhausted, a tone sounds and the display shows *Emergency Alarm Failed*.

---
- 4 Radio exits the Emergency Alarm mode and returns to the Home screen.

---

*If your radio is set to Silent, it will not display any audio or visual indicators during Emergency mode.*



## Sending an Emergency Alarm with Call

This feature allows you send an Emergency Alarm to another radio. Upon acknowledgement, both radios can communicate over a programmed Emergency channel.

### Procedure:

- 1 Press the programmed **Emergency** button.
- 2 The display shows **Sending Alarm**, which alternates with your radio ID. The LED lights up solid green and the Emergency icon appears on the Home screen display.
- 3 When an Emergency Alarm acknowledgment is received, the Emergency tone sounds and the LED blinks green. The display shows **Emergency Alarm Successful**.
- 4 Hold the radio vertically 1 to 2 inches (2.5 to 5.0 cm) from your mouth.
- 5 Press **PTT** button to make the call. The LED lights up solid green and the group icon appears on the display.
- 6 Wait for the Talk Permit Tone to finish (if enabled) and speak clearly into the microphone.
- 7 Release the **PTT** button to listen.
- 8 If the Channel Free Indication feature is enabled, you will hear a short alert tone the moment the target radio releases the **PTT** button, indicating the channel is free for you to respond. Press the **PTT** button to respond. 

### OR

Long press the programmed **Emergency** button to exit the Emergency mode.

- 9 The radio returns to the Home screen.

*If your radio is set to Silent, it will not display any audio or visual indicators during Emergency mode, or receive any response (call) from the target radio, until you press the **PTT** button to initiate the call.*

*If your radio is set to Silent with Voice, it will not display any audio or visual indicators during Emergency mode, or when you are receiving a call from the target radio. The indicators will only appear once you press the **PTT** button to initiate, or respond to, the call.*

## Sending an Emergency Alarm with Voice to Follow

This feature allows you to send an Emergency Alarm to another radio. Upon acknowledgement, your radio's microphone is automatically activated, allowing you to communicate with the other radio without pressing the **PTT** button.

This activated microphone state is also known as "hot mic".

If you press the **PTT** button during the programmed hot mic transmission period, the radio ignores the **PTT** press and remains in Emergency mode.

**NOTE:** If you press the **PTT** button during hot mic, and continue to press it after the hot mic duration expires, the radio continues to transmit until you release the **PTT** button.

#### Procedure:

- 1 Press the programmed **Emergency** button.
- 2 The display shows *Sending Alarm*. The LED lights up solid green and the Emergency icon is displayed.
- 3 Once the display shows *Emergency Alarm Successful*, speak clearly into the microphone. When hot mic has been enabled, the radio automatically transmits without a **PTT** press until the hot mic duration expires.
- 4 While transmitting, the LED lights up solid green and the Emergency icon appears on the display.
- 5 Once the hot mic duration expires, the radio automatically stops transmitting. To transmit again, press the **PTT** button.

*If your radio is set to Silent, it will not display any audio or visual indicators during Emergency mode, or receive any response from the target radio, until the programmed hot mic transmission period is over, and you press the **PTT** button.*

*If your radio is set to Silent with Voice, it will not display any audio or visual indicators during Emergency mode when you are making the call with hot mic, or when the target radio responds after the programmed hot mic transmission period is*

*over. The indicators will only appear when you press the **PTT** button.*

**NOTE:** If the Emergency Alarm request fails, the radio returns to the Home screen.

#### Reinitiating an Emergency Mode

There are two instances where this can happen:

- You change the channel while the radio is in Emergency mode. This exits the Emergency mode. If Emergency Alarm is enabled on this new channel, the radio reinitiates Emergency.
- You press the programmed **Emergency** button during an Emergency initiation/transmission state. This causes the radio to exit this state, and to reinitiate Emergency.

#### Exiting Emergency Mode

Your radio exits Emergency mode when **one** of the following occurs:



- Emergency Alarm acknowledgement is received (for **Emergency Alarm** only), **OR**
- All retries to send the alarm have been exhausted, **OR**
- The programmed **Emergency** button is long pressed.

**NOTE:** If your radio is powered off, it exits the Emergency mode. The radio will not reinitiate the Emergency mode automatically when it is turned on again.

## ■ Text Message Features

Your radio is able to receive data, for example a text message, from another radio or an e-mail application.

The **maximum** length of characters for a text message, including the subject line (seen when receiving message from an e-mail application), is **138**.

**NOTE:** Press  at any time to return to the previous screen or long press  to return to the Home screen.

### Writing and Sending a Text Message

#### Procedure:



Press the programmed **Text Message** button and proceed to step 3.

#### OR



Follow the procedure below.

- 1  to access the menu.



---

- 2  or  to Messages and press  to select.

---

- 3  or  to Write and press  to select.



---

- 4 A blinking cursor appears.  
Use the keypad to type your message.  
Press  to move one space to the left.  
Press  or the # key to move one space to the right.  
Press the \*DEL key to delete any unwanted characters.





---

- 5 Press  once message is composed.

---

- 6  or  to the required alias or ID and press  to select.

#### OR

 or  to Manual Dial and press  to select.  
Key in the subscriber ID and press .

---

- 7 The display shows Text Message: <Subscriber/Group Alias or ID>, confirming your message is being sent.

---

- 8 If the message is sent, a tone sounds and the display shows Message Sent.

#### OR

If the message is not sent, a low tone sounds and the display shows Message Send Failed.

---

*If the message fails to send, the radio returns you to the Resend option screen (see **Managing Fail-to-Send Text Messages** on page 43).*

## Sending a Quick Text Message

Your radio supports a maximum of ten (10) Quick Text messages as programmed by your dealer.













While Quick Text messages are predefined, you can edit each message before sending it.



### Procedure:

Press the programmed **Text Message** button and proceed to step 3.



### OR

Follow the procedure below.

- 1  to access the menu.
- 2  or  to **Messages** and press  to select.
- 3  or  to **Quick Text** and press  to select.
- 4  or  to the required Quick Text and press  to select.
- 5 A blinking cursor appears.  
Use the keypad to edit the message, if required.  
Press  to move one space to the left.  
Press  or the # key to move one space to the right.  
Press the \*DEL key to delete any unwanted characters.
- 6 Press  once message is composed.

- 7  or  to the required alias or ID and press  to select.

### OR

- 7  or  to **Manual Dial** and press  to select.

Key in the subscriber alias or ID and press .

- 8 The display shows **Text Message: <Subscriber/Group Alias or ID>**, confirming your message is being sent.
- 9 If the message is sent successfully, a tone sounds and the display shows **Message Sent**.  
**OR**  
If the message cannot be sent, a low tone sounds the display shows **Message Send Failed**.

*If the message fails to send, the radio returns you to the **Resend** option screen (see **Managing Fail-to-Send Text Messages** on page 43).*

## Sending a Quick Text Message with the One Touch Call Button

### Procedure:

- 1 Press the programmed **One Touch Call** button to send a predefined Quick Text message to a predefined alias or ID.

- 2 The display shows **Text Message: <Subscriber/Group Alias or ID>**, confirming your message is being sent.
- 3 If the message is sent successfully, a tone sounds and the display shows **Message Sent**.  
**OR**  
If the message cannot be sent, the display shows **Message Send Failed**.

If the message fails to send, the radio returns you to the *Resend* option screen (see **Managing Fail-to-Send Text Messages** on page 43).

### **Managing Fail-to-Send Text Messages**

You can select one of the following options while at the *Resend* option screen:

- Resend
- Forward
- Edit

### **Resending a Text Message**

**Procedure:**











- 1 Press  to resend the same message to the same subscriber/group alias or ID.

- 2 If the message is sent successfully, a tone sounds and the display shows **Message Sent**.  
**OR**  
If the message cannot be sent, the display shows **Message Send Failed**.

### **Forwarding a Text Message**

Select *Forward* to send the message to another subscriber/group alias or ID.

**Procedure:**













- 1  or  to *Forward* and press  to select.
- 2  or  to the required alias or ID and press  to select.  
**OR**  
 or  to *Manual Dial* and press  to select.  
Key in the subscriber ID and press .
- 3 The display shows **Text Message: <Subscriber/Group Alias or ID>**, confirming your message is being sent.
- 4 If the message is sent, a tone sounds and the display shows **Message Sent**.  
**OR**  
If the message is not sent, a low tone sounds and the display shows **Message Send Failed**.

## **Editing a Text Message**

Select **Edit** to edit the message before sending it.

**NOTE:** If a subject line is present (for messages received from an e-mail application), you cannot edit it.

### **Procedure:**



- 1  or  to **Edit** and press  to select.
- 2 A blinking cursor appears beside the message. Use the keypad to edit your message.  
Press  to move one space to the left.  
Press  or the # key to move one space to the right.  
Press the \*DEL key to delete any unwanted characters.
- 3 Press  once message is composed.
- 4  or  to the required alias or ID and press  to select.  
**OR**  
 or  to **Manual Dial** and press  to select.  
Key in the subscriber ID and press .

- 5 The display shows **Text Message: <Subscriber/Group Alias or ID>**, confirming your message is being sent.
- 6 If the message is sent, a tone sounds and the display shows **Message Sent**.  
**OR**  
If the message is not sent, a low tone sounds and the display shows **Message Send Failed**.

## **Managing Sent Text Messages**

Once a message is sent to another radio, it is saved in **Sent Items**. The most recent sent text message is always added to the top of the **Sent Items** list.

The **Sent Items** folder is capable of storing a maximum of thirty (30) last sent messages. When the folder is full, the next sent text message automatically replaces the oldest text message in the folder.

**NOTE:** Press  at any time to return to the previous screen or long press  to return to the Home screen.

## Viewing a Sent Text Message

### Procedure:



Press the programmed **Text Message** button and proceed to step 3.

### OR



Follow the procedure below.

- 1  to access the menu.



---

- 2  or  to **Messages** and press  to select.

---

- 3  or  to **Sent Items** and press  to select.

---

- 4  or  to the required message and press  to select.  
A subject line may be shown if the message is from an e-mail application.

The icon at the top right corner of the screen indicates the status of the message (see **Sent Item Icons** on page 11).

## Sending a Sent Text Message



You can select one of the following options while viewing a sent text message:

- Resend
- Forward
- Edit
- Delete

### Procedure:

- 1 Press  again while viewing the message.

---

- 2  or  to **Resend** and press  to select.



---

- 3 The display shows **Sending to: <Subscriber/Group Alias or ID>**, confirming that the same message is being sent to the same target radio.

---



- 4 If the message is sent, a tone sounds and the display shows **Message Sent**.  
**OR**  
If the message is not sent, a low tone sounds and the display shows **Message Send Failed**.

*If the message fails to send, the radio returns you to the **Resend option** screen. Press  to resend the message to the same subscriber/group alias or ID.*

**NOTE:** Changing the volume, and pressing any button, except for , , or , returns you to the message.

The radio exits the **Resend** option screen if you press the **PTT** button to initiate a Private or Group Call, or to respond to a Group Call. The radio also exits the screen when it receives a text or telemetry message, an emergency call or alarm, or a call alert.

The display returns to the **Resend** option screen if you press the **PTT** button to respond to a Private Call (except when the radio is displaying the Missed Call screen), and at the end of an All Call.

Press  or  to access the *Forward, Edit, or Delete* option screen:

- Select *Forward* to send the selected text message to another subscriber/group alias or ID (see **Forwarding a Text Message** on page 43).
- Select *Edit* to edit the selected text message before sending it (see **Editing a Text Message** on page 44).
- Select *Delete* to delete the text message.

**NOTE:** If you exit the message sending screen while the message is being sent, the radio updates the status of the message in the Sent Items folder without providing any indication in the display or via sound.

**NOTE:** If the radio changes mode or powers down before the status of the message in Sent Items is updated, the radio cannot complete any In-Progress messages and automatically marks it with a Send Failed icon.

The radio supports a maximum of five (5) In-Progress messages at one time. During this period, the radio cannot send any new message and automatically marks it with a Send Failed icon.

## **Deleting All Sent Text Messages from Sent Items**

### **Procedure:**



Press the programmed **Text Message** button and proceed to step 3.

### **OR**



Follow the procedure below.

- 1  to access the menu.



---

  - 2  or  to *Messages* and press  to select.





---

  - 3  or  to *Sent Items* and press  to select.

---

  - 4  or  to *Delete All* and press  to select.

---

  - 5 At *Delete Message?*, press  to select *Yes*. The display shows *Sent Items Cleared*.
- OR**
- At *Delete Message?*,  or  to *No* and press  to return to the previous screen.

*When you select Sent Items and it contains no text messages, the display shows List Empty, and sounds a low tone if Keypad Tones are turned on (see **Turning Keypad Tones On or Off** on page 54).*



## Receiving a Text Message

When your radio receives a message, the display shows the alias or ID of the sender and the message icon at the far left of the screen.





You can select one of the following options when receiving a text message:



- Read?
- Read Later
- Delete

**NOTE:** The radio exits the Text Message alert screen and sets up a Private or Group Call if the **PTT** button is pressed when the radio is displaying the alert screen.

## Reading a Text Message

### Procedure:

- 1 Press  or  to Read? and press  to select.
- 2 Selected message in the Inbox opens.  
A subject line may be shown if the message is from an e-mail application.
- 3 Press  to return to the Inbox.  
**OR**  
Press  to reply, forward, or delete the text message.

Press  or  to access the *Read Later* or *Delete* option screen:

- Select *Read Later* to return to the screen you were on prior to receiving the text message.
- Select *Delete* to delete the text message.



## Managing Received Text Messages

Use the Inbox to manage your text messages. The Inbox is capable of storing a maximum of 30 messages.

Your radio supports the following options for text messages:













- Reply
- Forward
- Delete
- Delete All

Text messages in the Inbox are sorted according to the most recently received.

**NOTE:** Press  at any time to return to the previous screen or long press  to return to the Home screen.

## Viewing a Text Message from the Inbox

### Procedure:

- 1  to access the menu.
- 2  or  to Messages and press  to select.
- 3  or  to Inbox and press  to select.
- 4  or  to view the messages.  
A subject line may be shown if the message is from an e-mail application.
- 5 Press  to select the current message, and press  again to reply, forward, or delete that message.  
**OR**  
Long press  to return to the Home screen.

*Unread messages are indicated with an exclamation mark (!).*

## Replying to a Text Message from the Inbox

### Procedure:



Press the programmed **Text Message** button and proceed to step 3.



### **OR**

Follow the procedure below.

- 1  to access the menu.



- 2  or  to Messages and press  to select.



- 3  or  to Inbox and press  to select.

- 4  or  to the required message and press  to select.

A subject line may be shown if the message is from an e-mail application.



- 5 Press  once more to access the sub-menu.

- 6  or  to Reply and press  to select.

- 7  or  to Write and press  to select.

A blinking cursor appears. Use the keypad to write your message.

### **OR**

-  or  to Quick Text and press  to select.

A blinking cursor appears. Use the keypad to edit your message, if required.

- 8 Press  once message is composed.

- 9 The display shows Text Message: <Subscriber/Group Alias or ID>, confirming your message is being sent.

**10** If the message is sent successfully, a tone sounds and the display shows *Message Sent*.

**OR**

If the message cannot be sent, the display shows *Message Send Failed*.

*If the message fails to send, the radio returns you to the *Resend* option screen (see **Managing Fail-to-Send Text Messages** on page 43).*

### **Deleting a Text Message from the Inbox**

**Procedure:**



Press the programmed **Text Message** button and proceed to step 3.

**OR**



Follow the procedure below.

- 1**  to access the menu.



---

- 2**  or  to *Messages* and press  to select.

---

- 3**  or  to *Inbox* and press  to select.



---



- 4**  or  to the required message and press  to select.  
A subject line may be shown if the message is from an e-mail application.

---

- 5** Press  once more to access the sub-menu.

---

- 6**  or  to *Delete* and press  to select.

**7** At *Delete Message?*,  or  to *Yes* and press  to select.

**8** The display shows *Message Deleted*.

**9** The screen returns to the *Inbox*.

### **Deleting All Text Messages from the Inbox**

**Procedure:**



Press the programmed **Text Message** button and proceed to step 3.

**OR**



Follow the procedure below.

- 1**  to access the menu.



---

- 2**  or  to *Messages* and press  to select.



---

- 3**  or  to *Inbox* and press  to select.

---

- 4**  or  to *Delete All* and press  to select.

---

- 5** At *Delete Message?*,  or  to *Yes* and press  to select.

---

- 6** The display shows *Inbox Cleared*.

*When you select the *Inbox* and it contains no text messages, the display shows *List Empty*, and sounds a low tone if **Keypad Tones** are turned on (see **Turning Keypad Tones On or Off** on page 54).*

## ■ Privacy

If enabled, this feature helps to prevent eavesdropping by unauthorized users on a channel by the use of a software-based scrambling solution. The signaling and user identification portions of a transmission are not scrambled.

Your radio must have privacy enabled on the channel to send a privacy-enabled transmission, although this is not a necessary requirement for receiving a transmission. While on a privacy-enabled channel, the radio is still able to receive clear (unscrambled) transmissions.

To unscramble a privacy-enabled call or data transmission, your radio must have the same Privacy Key (programmed by your dealer) as the transmitting radio. If your radio receives a scrambled call that is of a different Privacy Key, you will hear a garbled transmission.

The LED lights up solid green while the radio is transmitting and blinks green rapidly when the radio is receiving an ongoing privacy-enabled transmission.













**NOTE:** Some radio models may not offer this Privacy feature. Check with your dealer or system administrator for more information.

### Procedure:

Press the programmed **Privacy** button to toggle privacy on or off.

### OR

Follow the procedure below.

- 1  to access the menu.
- 2  or  to Utilities and press  to select.
- 3  or  to Radio Settings and press  to select.
- 4  or  to Privacy and press  to select.
- 5 The display shows Privacy and Turn On. Press  to enable privacy. The display shows Privacy On.  
**OR**  
The display shows Privacy and Turn Off. Press  to disable privacy. The display shows Privacy Off.

*When privacy is enabled, the Home screen shows the Privacy icon, except when the radio is sending or receiving an Emergency call or alarm.*

## ■ Dual Tone Multi Frequency (DTMF)

The Dual Tone Multi Frequency (DTMF) feature allows the radio to operate in a radio system with an interface to telephone systems.

To use this feature, your radio must have an access code, which is system dependent. Please check with your dealer or system administrator for more information.

### Procedure:

To initiate a DTMF call.

- 1 Enter the Access code.
- 2 Press and hold the **PTT** button.
- 3 Enter the desired number.

**NOTE:** You can turn off the DTMF tone by disabling all radio tones and alerts (see **Turning the Radio Tones/ Alerts On or Off** on page 56).

## ■ Security



You can enable or disable any radio in the system. For example, you might want to disable a stolen radio, to prevent the thief from using it, and enable that radio, when it is recovered.

**NOTE:** Performing Radio Disable and Enable is limited to radios with these functions enabled.

### Radio Disable

#### Procedure:







Using the programmed **Radio Disable** button.

- 1 Press the programmed **Radio Disable** button.
- 2  or  to the required alias or ID and press  to select.
- 3 The display shows Radio Disable: <Subscriber Alias or ID> and the LED lights up solid green.
- 4 Wait for acknowledgment.
- 5 If successful, a tone sounds and the display shows Radio Disable Successful.  
**OR**  
If not successful, a tone sounds and the display shows Radio Disable Failed.





OR



**Procedure:**

Using the menu.

- 1  to access the menu.
- 2  or  to `Contacts` and press  to select. The entries are alphabetically sorted.
- 3  or  to the required alias or ID and press  to select.

**OR**

 or  to `Manual Dial` and press  to select.  
Key in the subscriber alias or ID and press .

- 4  or  to `Radio Disable` and press  to select. The LED blinks green.
- 5 The display shows `Radio Disable: <Subscriber Alias or ID>` and the LED lights up solid green.

- 6 Wait for acknowledgment.

- 7 If successful, a tone sounds and the display shows `Radio Disable Successful`.

**OR**



If not successful, a tone sounds and the display shows `Radio Disable Failed`.

*Do not press  during the Radio Disable operation as you will not get an acknowledgement message.*

## Radio Enable

**Procedure:**

Using the programmed **Radio Enable** button.

- 1 Press the programmed **Radio Enable** button.
- 2  or  to the required alias or ID and press  to select.
- 3 The display shows `Radio Enable: <Subscriber Alias or ID>` and the LED lights up solid green.
- 4 Wait for acknowledgment.
- 5 If successful, a tone sounds and the display shows `Radio Enable Successful`.





**OR**



If not successful, a tone sounds and the display shows `Radio Enable Failed`.

**OR**



**Procedure:**

Using the menu.



- 1  to access the menu.
- 2  or  to `Contacts` and press  to select. The entries are alphabetically sorted.

3  or  to the required alias or ID and press  to select.

**OR**

 or  to Manual Dial and press  to select.

Key in the subscriber alias or ID and press .

4  or  to Radio Enable and press  to select. The LED blinks green.

5 The display shows Radio Enable: <Subscriber Alias or ID> and the LED lights up solid green.

6 Wait for acknowledgment.

7 If successful, a tone sounds and the display shows Radio Enable Successful.

**OR**

If not successful, a tone sounds and the display shows Radio Enable Failed.

*Do not press  during the Radio Enable operation as you will not get an acknowledgement message.*



## Utilities



### Locking and Unlocking the Keypad

You can lock your radio's keypad to avoid inadvertent key entry.

#### Procedure:

1  to access the menu.

2  or  to Utilities and press  to select.

3  or  to Radio Settings and press  to select.

4  or  to Keypad Lock and press  to select.

5 The display shows Keypad Locked and returns to the Home screen.















6 To unlock the keypad, press  followed by \*.

7 The display shows Keypad Unlocked and returns to the Home screen.

## Turning Keypad Tones On or Off

You can enable and disable keypad tones if needed.

### Procedure:

- 1  to access the menu.
- 2  or  to Utilities and press  to select.
- 3  or  to Radio Settings and press  to select.
- 4  or  to Tones/Alerts and press  to select.
- 5  or  to Keypad Tones and press  to select.
- 6 The display shows Turn On. Press  to enable keypad tones. The display shows Keypad Tone On.

### OR

The display shows Turn Off. Press  to disable keypad tones. The display shows Keypad Tone Off.

## Setting the Squelch Level

You can adjust your radio's squelch level to filter out unwanted calls with low signal strength or channels that have a higher than normal background noise.











**Settings:** Normal is the default. Tight filters out (unwanted) calls and/or background noise. However, calls from remote locations may also be filtered out.

### Procedure:

Press the programmed **Squelch** button to toggle squelch level between normal and tight.

### OR

Follow the procedure below.

- 1  to access the menu.
- 2  or  to Utilities and press  to select.
- 3  or  to Radio Settings and press  to select.
- 4  or  to Squelch and press  to select.
- 5 Choose either Tight or Normal and press  to select.
- 6 Screen returns to the previous menu.

## Setting the Power Level

You can customize your radio's power setting to high or low for each channel.

**Settings:** High enables communication with radios located at a considerable distance from you. Low enables communication with radios in closer proximity.

### Procedure:

Press the programmed **Power Level** button to toggle transmit power level between high and low.





**OR**



Follow the procedure below.

- 1  to access the menu.



---

- 2  or  to Utilities and press  to select.

---

- 3  or  to Radio Settings and press  to select.

---

- 4  or  to Power and press  to select.

---

- 5 Change your current setting as prompted on the display.

---

- 6 Press  to select a new power level.

---

- 7 Screen returns to the previous menu.

---

Long press  to return to the Home screen. The power level icon is visible.

### Turning the Option Board Feature(s) On or Off

A channel can support up to 6 option board features. Refer to your dealer or system administrator for more information.

**Procedure:**

Press the programmed **Option Board Feature** button to toggle the feature on or off.

### Controlling the Display Backlight

You can enable or disable the radio's display backlight as needed. The setting also affects the Menu Navigation Buttons and keypad backlighting accordingly.

**Procedure:**



Press the programmed **Backlight** button to toggle the backlight settings.

**OR**



Follow the procedure below.

- 1  to access the menu.



---

- 2  or  to Utilities and press  to select.

---

- 3  or  to Radio Settings and press  to select.

---

- 4  or  to Backlight and press  to select.

---

- 5 The display shows Auto On. Press  to enable the display backlight. The display shows Backlight Auto On.

---

- OR**  
The display shows Turn Off. Press  to disable the display backlight. The display shows Backlight Turn Off.

---

*The display backlight and keypad backlighting are automatically turned off if the LED indicator is disabled (see **Turning the LED Indicator On or Off** on page 57).*

## Turning the Radio Tones/Alerts On or Off

You can enable and disable all radio tones and alerts (except for the incoming Emergency alert tone) if needed.

### Procedure:



Press the programmed **All Tones/Alerts** button to toggle all tones on or off.

### OR



Follow the procedure below.

- 1  to access the menu.



---

- 2  or  to Utilities and press  to select.



---

- 3  or  to Radio Settings and press  to select.



---

- 4  or  to Tones/Alerts and press  to select.

---

- 5  or  to All Tones and press  to select.

---

- 6 The display shows Turn On. Press  to enable all tones and alerts. The display shows All Tones On.  
**OR**  
The display shows Turn Off. Press  to disable all tones and alerts. The display shows All Tones Off.



## Turning the Talk Permit Tone On or Off

You can enable and disable the Talk Permit Tone if needed.



### Procedure:

- 1  to access the menu.



---

- 2  or  to Utilities and press  to select.



---

- 3  or  to Radio Settings and press  to select.



---

- 4  or  to Tones/Alerts and press  to select.

---

- 5  or  to Talk Permit and press  to select.

---

- 6 The display shows Turn On. Press  to enable the Talk Permit Tone. The display shows Talk Permit Tone On.  
**OR**  
The display shows Turn Off. Press  to disable the Talk Permit Tone. The display shows Talk Permit Tone Off.



## Turning the LED Indicator On or Off

You can enable and disable the LED Indicator if needed.



### Procedure:

- 1  to access the menu.



---

- 2  or  to Utilities and press  to select.

---

- 3  or  to Radio Settings and press  to select.

---

- 4  or  to LED Indicator and press  to select.

---

- 5 The display shows Turn On. Press  to enable the LED Indicator. The display shows All LEDs On.

### OR

The display shows Turn Off. Press  to disable the LED Indicator. The display shows All LEDs Off.

*The display backlight, buttons, and keypad backlighting are automatically turned off if the LED indicator is disabled (see **Controlling the Display Backlight** on page 55).*



## Turning the Introduction Screen On or Off

You can enable and disable the Introduction Screen if needed.



### Procedure:

- 1  to access the menu.



---

- 2  or  to Utilities and press  to select.

---

- 3  or  to Radio Settings and press  to select.

---

- 4  or  to Intro Screen and press  to select.

---

- 5 The display shows Turn On. Press  to enable the Introduction Screen. The display shows Intro Screen On.



### OR

The display shows Turn Off. Press  to disable the Introduction Screen. The display shows Intro Screen Off.

## Accessing General Radio Information

Your radio contains information on the following:











- Battery
- Radio ID 
- Software Version
- Codeplug Version

**NOTE:** Press  at any time to return to the previous screen or long press  to return to the Home screen.

## Accessing the Battery Information

Displays information on your radio battery.

### Procedure:

- 1  to access the menu.
- 2  or  to Utilities and press  to select.
- 3  or  to Radio Info and press  to select.
- 4  or  to Battery Info and press  to select.

- 5 The display shows the battery information.



### OR

For **IMPRES** batteries **ONLY:** The display reads *Recondition Battery* if the battery requires reconditioning in an IMPRES charger.

After the reconditioning process, the display then shows the battery information.

---

### *For IMPRES batteries ONLY:*

Press  or  to access the *Capacity, First Use, or End of Life* option screen:

- Select *Capacity* to view battery capacity level, indicated by a horizontal bar and percentage reading.
- Select *First Use* to view the date of initial use.
- Select *End of Life* to view if the battery is still usable. The display shows *Replace Battery* if the battery has reached its end of life.



### **Checking the Radio ID**

Displays the ID of your radio.



#### **Procedure:**

- 1  to access the menu.



---

- 2  or  to Utilities and press  to select.

---

- 3  or  to Radio Info and press  to select.

---

- 4  or  to My Number and press  to select.

---

- 5 The radio ID is displayed.

---



### **Checking the Firmware Version**

Displays the firmware version on your radio.



#### **Procedure:**

- 1  to access the menu.



---

- 2  or  to Utilities and press  to select.

---

- 3  or  to Radio Info and press  to select.

---

- 4  or  to Firmware Ver. and press  to select.

---

- 5 The current firmware version is displayed.

---



### **Checking the Codeplug Version**

Displays the codeplug version on your radio.



#### **Procedure:**

- 1  to access the menu.



---

- 2  or  to Utilities and press  to select.

---

- 3  or  to Radio Info and press  to select.

---

- 4  or  to CP Ver. and press  to select.

---

- 5 The current codeplug version is displayed.

---

## Accessories

Your radio is compatible with the accessories listed in this chapter. Contact your dealer for details.

Antennas . . . . .	page 60
Batteries . . . . .	page 61
Carry Devices . . . . .	page 61
Chargers . . . . .	page 62
Earbuds and Earpieces . . . . .	page 62
Headsets and Headset Accessories . . . . .	page 62
Remote Speaker Microphones . . . . .	page 63
Surveillance Accessories . . . . .	page 63
Miscellaneous Accessories . . . . .	page 64

### ■ Antennas

The diagram on the right shows the location of the color indicator for the following antennas. See the footnote at the end of the list for the colors.



- Combination VHF/GPS, 136 – 147 MHz, Helical Antenna<sup>4</sup> (PMAD4067\_)
- Combination VHF/GPS, 147 – 160 MHz, Helical Antenna<sup>3</sup> (PMAD4068\_)

- Combination VHF/GPS, 160 – 174 MHz, Helical Antenna<sup>5</sup> (PMAD4069\_)
- VHF Wideband, 136 – 174 MHz, Double Helical Antenna<sup>6</sup> (PMAD4088\_)
- Combination UHF/GPS, 403 – 433 MHz, Folded Monopole Antenna<sup>1</sup> (PMAE4018\_)
- Combination UHF/GPS, 403 – 433 MHz, Stubby Antenna<sup>1</sup> (PMAE4021\_)
- UHF, 403 – 470 MHz, Whip Antenna<sup>3</sup> (PMAE4022\_)
- Combination UHF/GPS, 430 – 470 MHz, Stubby Antenna<sup>2</sup> (PMAE4023\_)
- Combination UHF/GPS, 430 – 470 MHz, Folded Monopole Antenna<sup>2</sup> (PMAE4024\_)
- Public Safety Microphone UHF Stubby Antenna<sup>1</sup>, 403 – 433 MHz (PMAE4046\_)
- Public Safety Microphone UHF Stubby Antenna<sup>2</sup>, 430 – 470 MHz (PMAE4047\_)
- UHF2, 450 – 527 MHz, Whip Antenna<sup>7</sup> (PMAE4049\_)
- Combination UHF2/GPS, 450 – 495 MHz, Folded Monopole Antenna<sup>8</sup> (PMAE4050\_)

- Combination UHF2/GPS, 495 – 527 MHz, Folded Monopole Antenna<sup>6</sup> (PMAE4051\_)
- Public Safety Microphone VHF Antenna<sup>5</sup>, 150 – 174 MHz (PMAD4086\_)
- Public Safety Microphone VHF Antenna<sup>4</sup>, 136 – 153 MHz (PMAD4087\_)

---

**Color Code:**

1 Red	3 Black	5 Blue	7 Brown
2 Green	4 Yellow	6 White	8 Orange

---

## ■ Batteries

- IMPRES Li-Ion, 1500 mAh Submersible (IP57) Battery (PMNN4066\_)
- IMPRES Li-Ion, 1400 mAh Submersible (IP57) Battery, Intrinsically Safe (FM) (PMNN4069\_)
- IMPRES Li-Ion, 2200 mAh Submersible (IP57) Battery (PMNN4077\_)
- NiMH, 1300 mAh Submersible (IP57) Battery (PMNN4065\_)

---

## ■ Carry Devices

- Belt Clip for 2-Inch Belt Width (PMLN4651\_)
- Belt Clip for 2.5-Inch Belt Width (PMLN4652\_)
- Nylon Carry Case with 3-Inch Fixed Belt Loop for Display Radio (PMLN5015\_)
- Soft Leather Carry Case with 2.5-Inch Swivel Belt Loop for Display Radio (PMLN5016\_)
- Soft Leather Carry Case with 3-Inch Swivel Belt Loop for Display Radio (PMLN5017\_)
- Soft Leather Carry Case with 3-Inch Fixed Belt Loop for Display Radio (PMLN5018\_)
- Hard Leather Carry Case with 2.5-Inch Swivel Belt Loop for Display Radio (PMLN5019\_)
- Hard Leather Carry Case with 3-Inch Swivel Belt Loop for Display Radio (PMLN5020\_)
- Hard Leather Carry Case with 3-Inch Fixed Belt Loop for Display Radio (PMLN5021\_)
- 2.5-Inch Replacement Swivel Belt Loop (PMLN5022\_)
- 3-Inch Replacement Swivel Belt Loop (PMLN5023\_)
- 1.75-Inch Black Leather Belt (4200865599)

## ■ Chargers

---

- IMPRES Multi-Unit Charger (WPLN4212\_)
- IMPRES Multi-Unit Charger with Displays (WPLN4219\_)
- IMPRES Single-Unit Charger (WPLN4232\_)

## ■ Earbuds and Earpieces

---

- Receive-Only Earbud (AARLN4885\_)
- D-Shell Receive-Only Earpiece (PMLN4620\_)
- Receive-Only Earpiece (RLN4941\_)
- Over-the-Ear Receiver for Remote Speaker Microphone (WADN4190\_)
- D-Shell Earset (PMLN5096\_)
- IMPRES Temple Transducer (PMLN5101\_)
- Small Custom Earpiece for Surveillance Kits, Right Ear (RLN4760\_)
- Medium Custom Earpiece for Surveillance Kits, Right Ear (RLN4761\_)
- Large Custom Earpiece for Surveillance Kits, Right Ear (RLN4762\_)
- Small Custom Earpiece for Surveillance Kits, Left Ear (RLN4763\_)
- Medium Custom Earpiece for Surveillance Kits, Left Ear (RLN4764\_)
- Large Custom Earpiece for Surveillance Kits, Left Ear (RLN4765\_)
- Standard Earpiece, Black (RLN6279\_)
- Standard Earpiece, Beige (RLN6280\_)
- Replacement Foam Ear Pad and Windscreen (RLN6283\_)
- Earpiece with Acoustic Tube Assembly, Beige (RLN6284\_)
- Earpiece with Acoustic Tube Assembly, Black (RLN6285\_)
- Earpiece with High Noise Kit, Beige (RLN6288\_)
- Earpiece with High Noise Kit, Black (RLN6289\_)

## ■ Headsets and Headset Accessories

---

- Ultra-Lite Headset (PMLN5102\_)
- Lightweight Headset (RMN5058\_)



## ■ Remote Speaker Microphones

---

- Remote Speaker Microphone (PMMN4024\_)
- IMPRES Remote Speaker Microphone (PMMN4025\_)
- Remote Speaker Microphone, Submersible (IP57) (PMMN4040\_)
- IMPRES Public Safety Microphone, 30-Inch Cable (PMMN4041\_)\*
- IMPRES Public Safety Microphone, 24-Inch Cable (PMMN4042\_)\*
- IMPRES Public Safety Microphone, 18-Inch Cable (PMMN4043\_)\*
- IMPRES Remote Speaker Microphone, with Volume, IP57 (PMMN4046\_)
- IMPRES Submersible Public Safety Microphone, 30-Inch Cable (PMMN4047\_)\*
- IMPRES Submersible Public Safety Microphone, 24-Inch Cable (PMMN4048\_)\*
- IMPRES Submersible Public Safety Microphone, 18-Inch Cable (PMMN4049\_)\*
- IMPRES Remote Speaker Microphone, Noise-Canceling (PMMN4050\_)

- Remote Speaker Microphone Replacement Coil Cord Kit (For Use with PMMN4024\_ and PMMN4040\_) (RLN6074\_)
- Remote Speaker Microphone Replacement Coil Cord Kit (For Use with PMMN4025) (RLN6075\_)

---

\*Only applicable to UHF B1 (403 – 470 MHz) and VHF (136 – 174 MHz) bands.

## ■ Surveillance Accessories

---

- IMPRES 3-Wire Surveillance, Black (PMLN5097\_)
- IMPRES 3-Wire Surveillance, Beige (PMLN5106\_)
- IMPRES 3-Wire Surveillance Kit with Clear, Comfortable Acoustic Tube, Black (PMLN5111\_)
- IMPRES 3-Wire Surveillance Kit with Clear, Comfortable Acoustic Tube, Beige (PMLN5112\_)
- Receive Only Surveillance Kit, Black (Single Wire) (RLN5878\_)
- Receive Only Surveillance Kit, Beige (Single Wire) (RLN5879\_)
- IMPRES 2-Wire Surveillance Kit, Black (RLN5880\_)
- IMPRES 2-Wire Surveillance Kit, Beige (RLN5881\_)

- IMPRES 2-Wire Surveillance Kit with Clear, Comfortable Acoustic Tube, Black (RLN5882\_)
- IMPRES 2-Wire Surveillance Kit with Clear, Comfortable Acoustic Tube, Beige (RLN5883\_)
- Surveillance Low Noise Kit (RLN5886\_)
- Surveillance High Noise Kit (RLN5887\_)

## ■ Miscellaneous Accessories

---

- Universal Chest Pack (HLN6602\_)
- Waterproof Bag, Includes Large Carry Strap (HLN9985\_)
- Shoulder Strap (Attaches to D-Rings on Carry Case) (NTN5243\_)
- Small Clip, Epaulet Strap (RLN4295\_)
- Break-A-Way Chest Pack (RLN4570\_)

- Universal RadioPAK and Utility Case (Fanny Pack) (RLN4815\_)
- Replacement Ear Tips, Clear, Pack of 25 (For Use with RLN5886\_) (RLN6282\_)
- Replacement Strap for RLN4570\_ and HLN6602\_ Chest Packs (1505596Z02)
- Accessory Dust Cover (1571477L01)
- Replacement Foam Plugs, Pack of 50 (For Use with RLN5887\_) (5080384F72)
- Universal RadioPAK Extension Belt (4280384F89)

## Batteries and Chargers Warranty

### The Workmanship Warranty

The workmanship warranty guarantees against defects in workmanship under normal use and service.

All MOTOTRBO Batteries	Two (2) Years
IMPRES Chargers (Single-Unit and Multi-Unit, Non-Display)	Two (2) Years
IMPRES Chargers (Multi-Unit with Display)	One (1) Year

### The Capacity Warranty

The capacity warranty guarantees 80% of the rated capacity for the warranty duration.

Nickel Metal-Hydride (NiMH) or Lithium-Ion (Li-Ion) Batteries	12 Months
IMPRES Batteries, When Used Exclusively with IMPRES Chargers	18 Months

# Limited Warranty

## MOTOROLA COMMUNICATION PRODUCTS

### I. WHAT THIS WARRANTY COVERS AND FOR HOW LONG:

MOTOROLA INC. ("MOTOROLA") warrants the MOTOROLA manufactured Communication Products listed below ("Product") against defects in material and workmanship under normal use and service for a period of time from the date of purchase as scheduled below:

XPR Series Digital Portable Radios	Two (2) Years
Product Accessories (Excluding Batteries and Chargers)	One (1) Year

MOTOROLA, at its option, will at no charge either repair the Product (with new or reconditioned parts), replace it (with a new or reconditioned Product), or refund the purchase price of the Product during the warranty period provided it is returned in accordance with the terms of this warranty. Replaced parts or boards are warranted for the balance of the original applicable warranty period. All replaced parts of Product shall become the property of MOTOROLA.

This express limited warranty is extended by MOTOROLA to the original end user purchaser only and is not assignable or transferable to any other party. This is the complete warranty for the Product manufactured by MOTOROLA. MOTOROLA assumes no

obligations or liability for additions or modifications to this warranty unless made in writing and signed by an officer of MOTOROLA.

Unless made in a separate agreement between MOTOROLA and the original end user purchaser, MOTOROLA does not warrant the installation, maintenance or service of the Product.

MOTOROLA cannot be responsible in any way for any ancillary equipment not furnished by MOTOROLA which is attached to or used in connection with the Product, or for operation of the Product with any ancillary equipment, and all such equipment is expressly excluded from this warranty. Because each system which may use the Product is unique, MOTOROLA disclaims liability for range, coverage, or operation of the system as a whole under this warranty.

### II. GENERAL PROVISIONS:

This warranty sets forth the full extent of MOTOROLA'S responsibilities regarding the Product. Repair, replacement or refund of the purchase price, at MOTOROLA'S option, is the exclusive remedy. THIS WARRANTY IS GIVEN IN LIEU OF ALL OTHER EXPRESS WARRANTIES. IMPLIED WARRANTIES, INCLUDING WITHOUT LIMITATION, IMPLIED WARRANTIES OF MERCHANTABILITY AND FITNESS FOR A PARTICULAR PURPOSE, ARE LIMITED TO THE DURATION OF THIS LIMITED WARRANTY. IN NO EVENT SHALL MOTOROLA BE LIABLE FOR DAMAGES IN EXCESS OF THE PURCHASE PRICE OF THE PRODUCT, FOR ANY LOSS OF USE, LOSS OF TIME, INCONVENIENCE, COMMERCIAL LOSS, LOST PROFITS OR SAVINGS OR OTHER INCIDENTAL, SPECIAL OR CONSEQUENTIAL DAMAGES ARISING OUT OF THE USE OR

INABILITY TO USE SUCH PRODUCT, TO THE FULL EXTENT SUCH MAY BE DISCLAIMED BY LAW.

### III. STATE LAW RIGHTS:

SOME STATES DO NOT ALLOW THE EXCLUSION OR LIMITATION OF INCIDENTAL OR CONSEQUENTIAL DAMAGES OR LIMITATION ON HOW LONG AN IMPLIED WARRANTY LASTS, SO THE ABOVE LIMITATION OR EXCLUSIONS MAY NOT APPLY.

This warranty gives specific legal rights, and there may be other rights which may vary from state to state.

### IV. HOW TO GET WARRANTY SERVICE:

You must provide proof of purchase (bearing the date of purchase and Product item serial number) in order to receive warranty service and, also, deliver or send the Product item, transportation and insurance prepaid, to an authorized warranty service location. Warranty service will be provided by MOTOROLA through one of its authorized warranty service locations. If you first contact the company which sold you the Product (e.g., dealer or communication service provider), it can facilitate your obtaining warranty service. You can also call MOTOROLA at 1-800-927-2744 US/Canada.

### V. WHAT THIS WARRANTY DOES NOT COVER:

- A) Defects or damage resulting from use of the Product in other than its normal and customary manner.
- B) Defects or damage from misuse, accident, water, or neglect.

- C) Defects or damage from improper testing, operation, maintenance, installation, alteration, modification, or adjustment.
- D) Breakage or damage to antennas unless caused directly by defects in material workmanship.
- E) A Product subjected to unauthorized Product modifications, disassembles or repairs (including, without limitation, the addition to the Product of non-MOTOROLA supplied equipment) which adversely affect performance of the Product or interfere with MOTOROLA's normal warranty inspection and testing of the Product to verify any warranty claim.
- F) Product which has had the serial number removed or made illegible.
- G) Rechargeable batteries if:
  - (1) any of the seals on the battery enclosure of cells are broken or show evidence of tampering.
  - (2) the damage or defect is caused by charging or using the battery in equipment or service other than the Product for which it is specified.
- H) Freight costs to the repair depot.
- I) A Product which, due to illegal or unauthorized alteration of the software/firmware in the Product, does not function in accordance with MOTOROLA's published specifications or the FCC type acceptance labeling in effect for the Product at the time the Product was initially distributed from MOTOROLA.
- J) Scratches or other cosmetic damage to Product surfaces that does not affect the operation of the Product.
- K) Normal and customary wear and tear.

## VI. PATENT AND SOFTWARE PROVISIONS:

MOTOROLA will defend, at its own expense, any suit brought against the end user purchaser to the extent that it is based on a claim that the Product or parts infringe a United States patent, and MOTOROLA will pay those costs and damages finally awarded against the end user purchaser in any such suit which are attributable to any such claim, but such defense and payments are conditioned on the following:

- A) that MOTOROLA will be notified promptly in writing by such purchaser of any notice of such claim;
- B) that MOTOROLA will have sole control of the defense of such suit and all negotiations for its settlement or compromise; and
- C) should the Product or parts become, or in MOTOROLA's opinion be likely to become, the subject of a claim of infringement of a United States patent, that such purchaser will permit MOTOROLA, at its option and expense, either to procure for such purchaser the right to continue using the Product or parts or to replace or modify the same so that it becomes non-infringing or to grant such purchaser a credit for the Product or parts as depreciated and accept its return. The depreciation will be an equal amount per year over the lifetime of the Product or parts as established by MOTOROLA.

MOTOROLA will have no liability with respect to any claim of patent infringement which is based upon the combination of the Product or parts furnished hereunder with software, apparatus or devices not furnished by MOTOROLA, nor will MOTOROLA have any liability for the use of ancillary equipment or software not furnished by MOTOROLA which is attached to or used in connection with the Product. The foregoing states the entire liability of MOTOROLA with respect to infringement of patents by the Product or any parts thereof.

Laws in the United States and other countries preserve for MOTOROLA certain exclusive rights for copyrighted MOTOROLA software such as the exclusive rights to reproduce in copies and distribute copies of such MOTOROLA software. MOTOROLA software may be used in only the Product in which the software was originally embodied and such software in such Product may not be replaced, copied, distributed, modified in any way, or used to produce any derivative thereof. No other use including, without limitation, alteration, modification, reproduction, distribution, or reverse engineering of such MOTOROLA software or exercise of rights in such MOTOROLA software is permitted. No license is granted by implication, estoppel or otherwise under MOTOROLA patent rights or copyrights.

## VII. GOVERNING LAW:

This Warranty is governed by the laws of the State of Illinois, U.S.A.



# XPR Series Digital Portable Radios Quick Reference Card

## Radio Controls

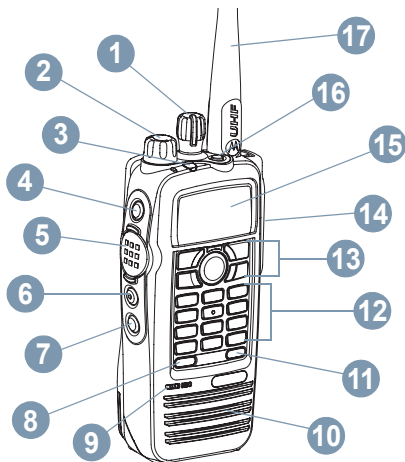

Record your radio's programmable button functions in the blanks provided. **SP** represents Short Press, **LP** represents Long Press.

- 1 Channel Selector Knob
- 2 On/Off/Volume Control Knob

- 3 LED Indicator
- 4 Side Button 1 (Programmable)  
SP: \_\_\_\_\_ LP: \_\_\_\_\_
- 5 Push-to-Talk (PTT) Button
- 6 Side Button 2 (Programmable)  
SP: \_\_\_\_\_ LP: \_\_\_\_\_
- 7 Side Button 3 (Programmable)  
SP: \_\_\_\_\_ LP: \_\_\_\_\_
- 8 Front Button P1 (Programmable)  
SP: \_\_\_\_\_ LP: \_\_\_\_\_
- 9 Microphone
- 10 Speaker
- 11 Front Button P2 (Programmable)  
SP: \_\_\_\_\_ LP: \_\_\_\_\_
- 12 Keypad
- 13 Menu Navigation Keys
- 14 Universal Connector for Accessories
- 15 Display
- 16 Emergency Button (Programmable)  
SP: \_\_\_\_\_ LP: \_\_\_\_\_
- 17 Antenna

## Menu Navigation Buttons

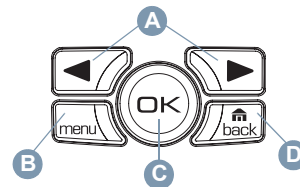

- A Left/Right Navigation Keys
- B Menu Button
- C OK Button
- D Back/Home Button

## Display Icons

The following are the icons that appear on the radio's display.

The number of bars displayed represents the radio signal strength. Four bars indicates the strongest signal. This icon is only displayed while receiving.

Selected channel is being monitored.

Radio is currently set at Low Power (L) or High Power (H).



Tones are turned off.



The Option Board is enabled.







6880309T13-D



 The Option Board is disabled.



 The GPS feature is enabled. The icon stays lit when a position fix is available. 

 The GPS feature is enabled but is not receiving data from the satellite. 



 Scan feature is enabled.

 Radio recognizes activity on the channel/group designated as Priority 1 (if  is blinking) or as Priority 2 (if  is steady).

 Unread message in the Inbox. 

 User's Inbox is full. 

 Radio is in Emergency mode.

 The Privacy feature is enabled. 

 Radio bypasses the repeater and communicates directly with another radio.

 The number of bars (0 – 4) shown indicates the charge remaining in the battery. Blinks when the battery is low.

## ■ Call Icons

The following icons appear during a call, and in the Contacts list to indicate ID type.

 Indicates a Private Call in progress. In Contacts list, it indicates a subscriber alias or ID.



 Indicates a Group Call or All Call in progress. In Contacts list, it indicates a group alias or ID.

## ■ Sent Items Icons

The following icons appear at the top right corner of the radio's display in the Sent Items folder.

 The text message is sent successfully.

 The text message cannot be sent.

-  • The text message to a group alias or ID is pending transmission.
-  • The text message to a subscriber alias or ID is pending transmission, followed by waiting for acknowledgement.

## ■ Powering Up and Turning Off the Radio

Rotate the On/Off/Volume Control Knob clockwise until you hear a click to turn on the radio, and counterclockwise until you hear a click to turn it off.

## ■ Adjusting the Volume

Turn the On/Off/Volume Control Knob clockwise or counterclockwise.

## ■ LED Indicator

**Blinking red** – Radio is receiving an Emergency transmission or has failed the self-test upon powering up.

**Solid yellow** – Radio is receiving a request for a Private Call, or monitoring a channel.

**Blinking yellow** – Radio is scanning for activity or receiving a Call Alert.

**Solid green** – Radio is transmitting.

**Blinking green** – Radio is powering up, receiving a non-privacy-enabled call or data, or detecting activity over the air.

**Rapidly blinking green** – Radio is receiving a privacy-enabled call or data. 



## ■ Selecting a Zone

Press the programmed **Zone** button and proceed to step 3.

**OR**

Follow the procedure below.

1  to access the menu.

2  or  to **Zone** and press  to select.

3 The current zone is displayed and indicated by a ✓.



4 or to the required zone and press to select.

---

5 The display shows <Zone> Selected momentarily and returns to the selected zone screen.

---

### ■ Selecting a Radio Channel, Subscriber ID, or Group ID

1 Turn the On/Off/Volume Control Knob to power up your radio.

---

2 Turn the Channel Selector Knob to select the required channel, subscriber ID, or group ID.

---

### ■ Making a Group Call

Press the programmed **One Touch Call** button and proceed to step 2.

**OR**

Follow the procedure below.

1 Turn the Channel Selector Knob to select the channel with the active group alias or ID.

**OR**

to access the menu.

or to **Contacts**. Press to select.

or to the alias or ID you want to call and press to select.

---

2 Hold the radio vertically 1 to 2 inches (2.5 to 5.0 cm) from your mouth.

---

3 Press the **PTT** button to make the call. The LED lights up solid green. The display shows the group alias or ID, and the Group Call icon.

---

4 Wait for the Talk Permit Tone to finish (if enabled). Speak clearly into the microphone.

---

5 Release the **PTT** button to listen. When the target radio responds, the LED blinks green. Display shows the Group Call icon, the group ID, and target radio ID.

---

6 If the Channel Free Indication feature is enabled, you will hear a short alert tone the moment the target radio releases the **PTT** button, indicating the channel is free for you to respond. Press the **PTT** button to respond.

**OR**

If there is no voice activity for a programmed period of time, the call ends.

---

*To make a call to a group of users, your radio must be configured as part of that group.*

*Your radio must have the Privacy feature enabled on the channel to send a privacy-enabled transmission. Only target radios with the same Privacy Key as your radio will be able to unscramble the transmission.*

---

### ■ Making a Private Call

Press the programmed **One Touch Call** button and proceed to step 2.

**OR**

Follow the procedure below.

1 Turn the Channel Selector Knob to select the channel with the active subscriber alias or ID.

**OR**

to access the menu.

or to **Contacts**. Press to select.

or to the ID you want to call and press to select.

---

2 Hold the radio vertically 1 to 2 inches (2.5 to 5.0 cm) from your mouth.

---

3 Press the **PTT** button to make the call. The LED lights up solid green. The first line displays the subscriber alias or ID. The second line displays **Private Call** and the Private Call icon.

---

4 Wait for the Talk Permit Tone to finish (if enabled). Speak clearly into the microphone.

---

5 Release the **PTT** button to listen. When the target radio responds, the LED blinks green.

---

- If the Channel Free Indication feature is enabled, you will hear a short alert tone the moment the target radio releases the **PTT** button, indicating the channel is free for you to respond. Press the **PTT** button to respond.

**OR**

If there is no voice activity for a programmed period of time, the call ends.

- You hear a short tone. The display shows Call Ended.

*Your radio must have the Privacy feature enabled on the channel to send a privacy-enabled transmission. Only target radios with the same Privacy Key as your radio will be able to unscramble the transmission.*

## ■ Making an All Call

Your radio must be programmed to allow you to use this feature. Users on the channel cannot respond to an All Call.

- Turn the Channel Selector Knob to select the channel with the active All Call group alias or ID.
- Hold the radio vertically 1 to 2 inches (2.5 to 5.0 cm) from your mouth.
- Press the **PTT** button to make the call. The LED lights up solid green. The display shows the All Call group alias or ID, and the All Call icon.

- Wait for the Talk Permit Tone to finish (if enabled). Speak clearly into the microphone.

- If there is no voice activity for a programmed period of time, the call ends.

*When you **receive** an All Call, a message appears and remains on your radio's display until the call ends. You will not be able to continue with any menu navigation or editing until the call ends.*





*Once the All Call ends, the radio returns to the menu prior to receiving the call.*

## ■ Scanning Channels

Press the programmed **Scan** button to turn scan on or off.

**OR**

Follow the procedure below.

-  to access the menu.
-  or  to Scan and press  to select.
- You see Scan On or Scan Off depending on previous selection.











*During scan, the LED blinks yellow and the scan icon is displayed.*

## ■ Making a Call Alert

Press the programmed **One Touch Call** button and proceed to step 5.

**OR**

Follow the procedure below.

-  to access the menu.
-  or  to Contacts. Press  to select.
-  or  to the required subscriber alias or ID and press  to select.
-  or  to Call Alert and press  to select.
- The display shows Call Alert: <Subscriber Alias or ID>. The LED lights up solid green.
- If the Call Alert acknowledgement is received, a tone sounds. Display shows Call Alert Successful.  
**OR**  
If the Call Alert acknowledgement is not received, a tone sounds. Display shows Call Alert Failed.

## ■ Sending a Quick Text Message













Press the programmed **Text Message** button and proceed to step 3.

### OR

Press the programmed **One Touch Call** button to send a predefined Quick Text message to a predefined alias or ID and proceed to step 6.

### OR

Follow the procedure below.

- 1  to access the menu.
- 2  or  to Messages. Press  to select.
- 3  or  to Quick Text and press  to select.
- 4  or  to the required Quick Text and press  to select.
- 5  or  to the required alias or ID and press  to select.
- 6 The display shows Text Message:  
<Subscriber/Group Alias or ID>.
- 7 If the message is sent successfully, a tone sounds. Display shows Message Sent.

### OR

If the message cannot be sent, the display shows Message Send Failed.

*If the message fails to send, the radio returns you to the Resend option screen.*

- Press  to resend the message to the same subscriber/group alias or ID.

- Select *Forward* to send the message to another subscriber/group alias or ID.
- Select *Edit* to edit the message before sending it.

**NOTE:** Once a message is sent to another radio, it is saved in Sent Items. The most recent sent text message is always added to the top of the Sent Items list.

The Sent Items folder stores a maximum of thirty (30) last sent messages. When the folder is full, the next sent text message automatically replaces the oldest text message in the folder.











The icon at the top right corner of the screen indicates the status of the message.

## ■ Replying to a Text Message with Quick Text from the Inbox



Press the programmed **Text Message** button and proceed to step 3.



### OR

Follow the procedure below.

- 1  to access the menu.
- 2  or  to Messages. Press  to select.
- 3  or  to Inbox. Press  to select.
- 4  or  to the required message and press  to select.  
A subject line may be shown if the message is from an e-mail application.

- 5 Press  once more to access the sub-menu.

- 6  or  to Reply and press  to select.

- 7  or  to Quick Text and press  to select.

- 8 Press  once more to send the reply.

- 9 The display shows Text Message:  
<Subscriber/Group Alias or ID>.

- 10 If the message is sent successfully, a tone sounds. Display shows Message Sent.

### OR

If the message cannot be sent, the display shows Message Send Failed.

*If the message fails to send, the radio returns you to the Resend option screen.*

- Press  to resend the message to the same subscriber/group alias or ID.
- Select *Forward* to send the message to another subscriber/group alias or ID.
- Select *Edit* to edit the message before sending it.

## ■ Sending an Emergency Alarm

- 1 Press the programmed **Emergency** button.
- 2 The display shows *Sending Alarm*, which alternates with your radio ID. The LED lights up solid green and the Emergency icon appears on the Home screen display.
- 3 When an Emergency Alarm acknowledgment is received, the Emergency tone sounds and the LED blinks green. The display shows *Emergency Alarm Successful*.  
**OR**  
If your radio does not receive an Emergency Alarm acknowledgement, and after all retries have been exhausted, a tone sounds and the display shows *Emergency Alarm Failed*.
- 4 Radio exits the Emergency Alarm mode and returns to the Home screen.













*If your radio is set to Silent, it will not display any audio or visual indicators during Emergency mode.*

## ■ Privacy

Press the programmed **Privacy** button to toggle privacy on or off.

### **OR**

Follow the procedure below.

- 1  to access the menu.
- 2  or  to Utilities. Press  to select.
- 3  or  to Radio Settings. Press  to select.
- 4  or  to Privacy. Press  to select.
- 5 The display shows *Privacy and Turn On*. Press  to enable privacy. The display shows *Privacy On*.  
**OR**  
The display shows *Privacy and Turn On*. Press  to disable privacy. The display shows *Privacy Off*.





**MOTOROLA**

Motorola, Inc.  
1301 E. Algonquin Rd.  
Schaumburg, IL 60196-1078, U.S.A.

MOTOROLA and the Stylized M Logo are  
registered in the U.S. Patent and Trademark Office.  
All other product or service names are the property  
of their respective owners.

© 2006 – 2008 by Motorola, Inc.  
All rights reserved. Printed in the U.S.A.  
April 2008

[www.motorola.com/mototrbo](http://www.motorola.com/mototrbo)



6880309T24-D