

ThinkCore W311/321/341

Hardware User's Manual

First Edition, December 2006

www.moxa.com/product



Moxa Systems Co., Ltd.

Tel: +886-2-8919-1711

Fax: +886-2-8919-1722

Web: www.moxa.com

MOXA Technical Support

Worldwide: support@moxa.com

The Americas: support@usa.moxa.com

ThinkCore W311/321/341 Hardware User's Manual

The software described in this manual is furnished under a license agreement and may be used only in accordance with the terms of that agreement.

Copyright Notice

Copyright © 2006 Moxa Systems Co., Ltd.
All rights reserved.
Reproduction without permission is prohibited.

Trademarks

MOXA is a registered trademark of The MOXA Group.
All other trademarks or registered marks in this manual belong to their respective manufacturers.

Disclaimer

Information in this document is subject to change without notice and does not represent a commitment on the part of MOXA.

MOXA provides this document "as is," without warranty of any kind, either expressed or implied, including, but not limited to, its particular purpose. MOXA reserves the right to make improvements and/or changes to this manual, or to the products and/or the programs described in this manual, at any time.

Information provided in this manual is intended to be accurate and reliable. However, MOXA assumes no responsibility for its use, or for any infringements on the rights of third parties that may result from its use.

This product might include unintentional technical or typographical errors. Changes are periodically made to the information herein to correct such errors, and these changes are incorporated into new editions of the publication.

Table of Contents

Chapter 1	Introduction	1-1
	Overview.....	1-2
	Package Checklist.....	1-2
	Product Features	1-3
	Product Hardware Specifications.....	1-3
	Hardware Block Diagram	1-6
	ThinkCore W311	1-6
	ThinkCore W321	1-6
	ThinkCore W341	1-7
Chapter 2	Hardware Introduction.....	2-1
	Appearance	2-2
	ThinkCore W311	2-2
	ThinkCore W321	2-2
	ThinkCore W341	2-3
	Dimensions	2-4
	ThinkCore W311	2-4
	ThinkCore W321	2-5
	ThinkCore W341	2-6
	LED Indicators.....	2-7
	Reset Button.....	2-7
	Real Time Clock	2-8
Chapter 3	Hardware Connection Description	3-1
	Wiring Requirements	3-2
	Connecting the Power.....	3-2
	Grounding the Unit.....	3-2
	Connecting Data Transmission Cables	3-3
	Connecting to the Network.....	3-3
	Connecting to the WLAN.....	3-3
	Connecting to a Serial Device	3-4
	Serial Console Port	3-4
	SD Slot (W321 and W341 only).....	3-4
	USB (W341 only).....	3-5
	Relay Output (W341 only).....	3-5
Appendix A	FCC Warning Statement	A-1
Appendix B	Service Information.....	B-1
	MOXA Internet Services.....	B-2
	Problem Report Form	B-3
	Product Return Procedure	B-4

The ThinkCore W300 Series is a line of wireless RISC-based embedded computers that feature 802.11a/b/g WLAN, RS-232/422/485 serial ports, and an Ethernet port in a small, rugged chassis. In addition, the W321 and W341 models feature an SD slot, and the W341 features two USB 2.0 hosts and one relay output channel.

As part of the W300 Series, your embedded computer is ideal for diverse, machine-to-machine embedded applications. It enables wireless operation of traditionally wired network and serial devices and not only provides transparent data transfer, but also numeric computing, protocol conversion, data processing and even data encryption. You will find it easier to build embedded systems for distributed peer-to-peer communication, turn wired devices into wireless devices, and introduce higher mobility and more intelligence to your system. In this chapter, learn about the capabilities of the embedded computer.

This chapter covers the following topics:

- ❑ **Overview**
- ❑ **Package Checklist**
- ❑ **Product Features**
- ❑ **Product Hardware Specifications**
- ❑ **Hardware Block Diagram**
 - ThinkCore W311
 - ThinkCore W321
 - ThinkCore W341

Overview

The ThinkCore W300 Series wireless embedded computer is designed around the MOXA ART ARM9 32-bit RISC processor. Unlike the X86 CPU, which uses a CISC design, the MOXA ART ARM9 uses RISC architecture and modern semiconductor technology to provide a powerful computing engine without generating significant heat. The processor also integrates UART and LAN functions to provide exceptional communication performance, but without the bus bandwidth limitations associated with general ARM-based communication products.

On-board NOR Flash ROM and SDRAM provides ample storage capacity, and for select models, the SD slot gives applications extra room to expand. The built-in WLAN function supports the 802.11a/b/g standard, providing transmission security with WEP, WPA and WPA2. The backup LAN port not only provides an alternative solution for networking but also supports Ethernet clients, allowing any network device to plug in and connect to the WLAN. The built-in RS-232/422/485 serial ports support a wide range of serial devices, making this platform suitable for data acquisition and protocol conversion applications.

The Linux-based operating system comes pre-installed and ready to run, providing an open platform for software development. Software written for desktop PCs can easily be ported to W300 Series embedded computers by using a common compiler, so little time is spent modifying existing software code. In addition, the operating system, device drivers, and user-developed software can all be stored in the built-in flash memory.

Package Checklist

The ThinkCore W300 Series includes the following models:

ThinkCore W311-LX

A small, RISC-based, ready-to-run, wireless embedded computer with WLAN, one serial ports, Ethernet, and μ Clinux OS

ThinkCore W321-LX

A small, RISC-based, ready-to-run, wireless embedded computer with WLAN, two serial ports, Ethernet, SD slot, and μ Clinux OS

ThinkCore W341-LX

A RISC-based, ready-to-run, wireless embedded computer with WLAN, four serial ports, Ethernet, SD slot, USB port, relay output, and Linux OS

Each model is shipped with the following items:

- ThinkCore W300 Series wireless embedded computer
- Quick Installation Guide
- Documentation & Software CD
- 100 cm RJ45-to-RJ45 Ethernet cross-over cable
- 100 cm console port cable (CBL-4PINDB9F-100)
- Universal Power Adaptor
- Product Warranty Statement

Optional Accessories

- 35 mm DIN-rail mounting kit (DK-35A)

NOTE: Notify your sales representative if any of the above items are missing or damaged.

Product Features

ThinkCore W300 Series computers have the following features:

- MOXAART 32-bit ARM9 industrial communication processor
- 16 MB on-board RAM (64 MB for W341)
- 8 MB built-in flash memory (16 MB for W341)
- 802.11a/b/g Wireless LAN
- WEP, WPA and WPA2 encryption
- Infrastructure mode and Ad-Hoc mode
- RS-232/422/485 serial ports with software selectable interface
- Baudrates between 50 and 921.6 Kbps, including all nonstandard baudrates
- 10/100M Ethernet for backup networking
- SD card slot for storage expansion (W321 and W341 only)
- Withstands 5G continuous vibration and 50G shock
- LED indicators for status, serial transmission, and wireless signal strength
- Ready-to-run Linux platform
- Installation on DIN-rail or wall
- Fanless design for increased ruggedness

Product Hardware Specifications

System

CPU	MOXA ART ARM9 32-bit RISC CPU, 192 MHz		
DRAM	W311: 16 MB	W321: 16 MB	W341: 64 MB
Flash	W311: 8 MB	W321: 16 MB	W341: 64 MB
Storage Expansion	W311: None	W321: SD slot × 1	W341: SD slot × 1
USB	W341: USB 2.0 host × 2		
Relay Output	Form C, SPDT × 1		
	Normal switching capacity:	2 A @30 VDC 60 W max.	
	Switching power:	220 VDC max.	
	Switching voltage:	2 A max.	
	Switch current:	4 ms @20°C	
	Operation time:	100 Mohm max.	
	Initial contact resistance:		
Console port	RS-232 × 1 (TxD, RxD, GND), 4-pin header output, “115200, n, 8, 1”		
Button	Reset button × 1, supports “Reset to Factory Default”		
Others	RTC, buzzer, Watchdog Timer		
OS	W311: μClinux, based on Linux Kernel 2.6 W321: μClinux, based on Linux Kernel 2.6 W341: Built-in Embedded Linux with MMU support		

WLAN Communication

Standard Compliance	802.11a/b/g
Radio Frequency Type	DSSS, CCK, OFDM
Radio Frequency Band	802.11a: 5.15 to 5.25 GHz (Indoor used only) 802.11b/g: U.S., Europe and Japan product covering 2.4 to 2.484 GHz
Media Access Protocol	Carrier Sense Multiple Access with Collision Avoidance (CSMA/CA)
Modulation	802.11a/g: OFDM (64-QAM, 16-QAM, QPSK, BPSK) 802.11b: DSSS (DBPSK, DQPSK, CCK)
Transmission Power (Typical)	5.15 to 5.25 GHz: 15 dBm @6 Mbps; 12 dBm @54 Mbps 2.412 to 2.462 GHz (IEEE802.11g): 17 dBm @6 Mbps; 15 dBm @54Mbps 2.412 to 2.462 GHz (IEEE802.11b): 18 dBm@ 1 to 11 Mbps
Receiver Sensitivity (Typical)	5.15 to 5.25 GHz: 6 Mbps @ -90 dBm; 54 Mbps @ -72 dBm 2.412 to 2.462 G (IEEE802.11g): 6 Mbps @ -90 dBm; 54 Mbps @ -73 dBm 2.412 to 2.462 G (IEEE802.11b): 11 Mbps @ -87 dBm; 1 Mbps @ -94 dBm
Transmission Rate	54 Mbps with auto fallback (54, 48, 36, 24, 18, 12, 11, 9, 6, 5.5, 2, 1 Mbps) 802.11b supported rates: 1, 2, 5.5, 11 Mbps 802.11a/g supported rates: 6, 9, 12, 18, 24, 36, 48, 54 Mbps
Transmission distance	100 meters at 11 Mbps (with no obstructions)
Security	WEP 64-bit/128-bit, WPA, WPA2 data encryption
Antenna Connector	Reverse SMA
Antenna	External 2 dBi dipole antenna
WLAN Mode	Infrastructure, Ad-Hoc

Network Communication

LAN	10/100 Mbps RJ45 × 1, auto-sensing
Protection	1.5 KV built-in magnetic isolation protection

Serial Communication

Serial Port	W311: RS-232/422/485 DB9 male × 1 W321: RS-232/422/485 DB9 male × 2 W341: RS-232/422/485 DB9 male × 4
Protection	15 KV built-in ESD protection for all signals
Data bits	5, 6, 7, 8
Stop bits	1, 1.5, 2
Parity	None, Even, Odd, Space, Mark
Flow Control	RTS/CTS, XON/XOFF, RS-485 ADDC™
Speed	50 bps to 921.6 Kbps, including all nonstandard baudrates

LEDs

System	Ready, SD activity (for W321 and W341 only)
WLAN	Enable, signal strength
LAN	10 M/Link, 100 M/Link
Serial	TxD, RxD

Power Requirements

Power Input	12 to 48 V
Power Consumption	W311: 250 mA @12 VDC, 3 W W321: 300 mA @12 VDC, 3.6 W W341: 540 mA @12 VDC, 6.5 W

Mechanical

Dimension (W × D × H)	(without wall mount ear or antenna) W311: 67 × 100.4 × 22 mm W321: 77 × 111 × 26 mm W341: 150 × 100 × 38 mm
Antenna	110 mm
Construction Material	W311: aluminum, 1 mm W321: aluminum, 1 mm W341: aluminum, 1 mm / SECC, 1 mm for rear panel
Mounting	DIN-rail, wall

Environmental

Operating Temperature	-10 to 60°C (14 to 140°F), 5 to 95% RH
Storage Temperature	-20 to 80°C (-4 to 176°F), 5 to 95% RH

Regulatory Approvals

EMC	FCC, CE
Safety	TÜV, UL, cUL
Others	RoHS, CRoHS, WEEE
Warranty	5 years

Hardware Block Diagram

ThinkCore W311

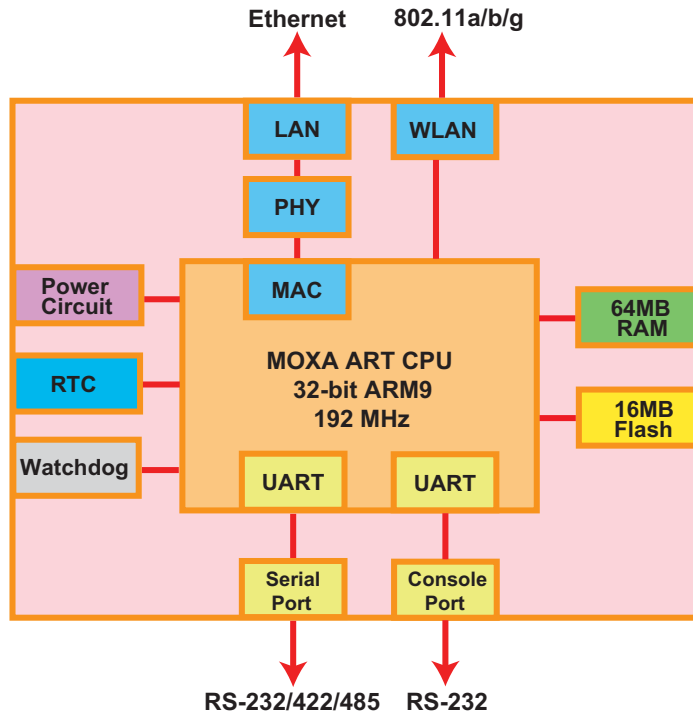

ThinkCore W321

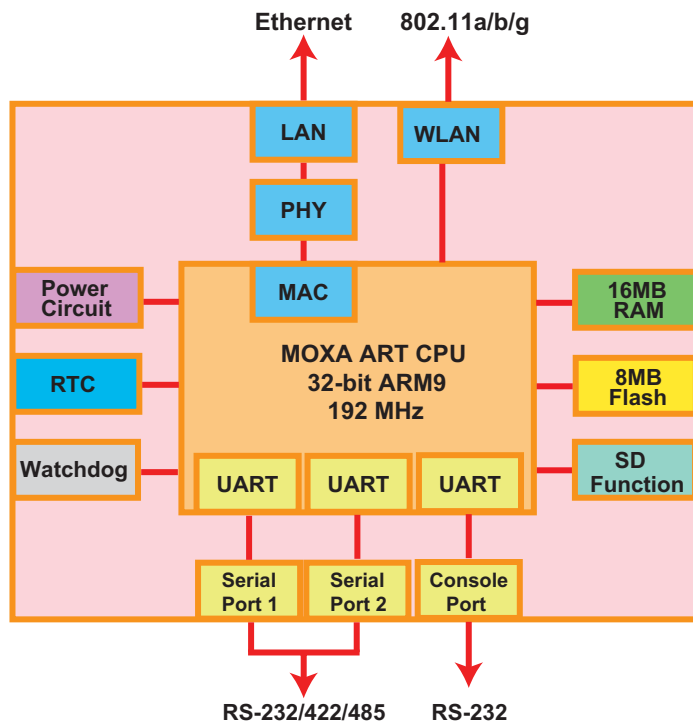

ThinkCore W341

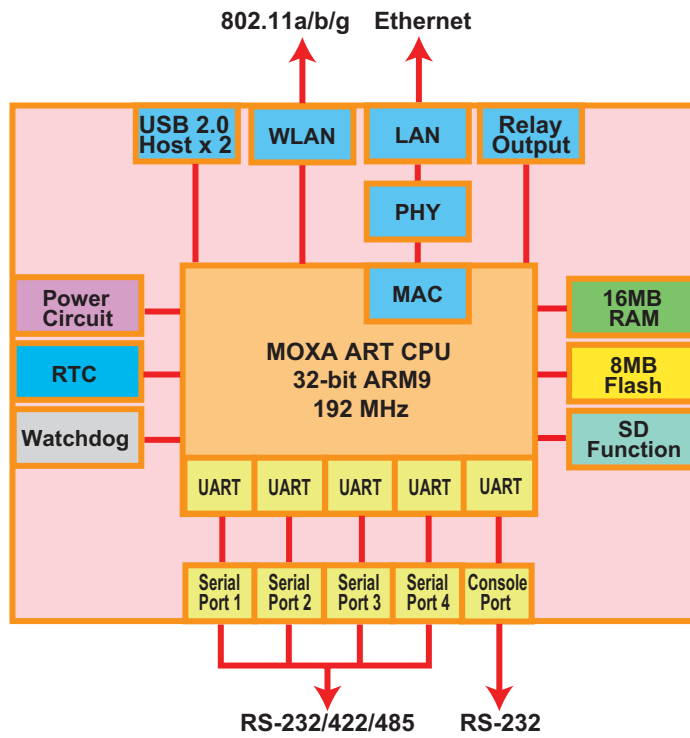

2

Hardware Introduction

ThinkCore W300 Series hardware is compact, well-designed, and built rugged for industrial applications. LED indicators help you monitor the performance and identify trouble spots. Multiple ports allow the connection of different devices for wireless operation. With the reliable and stable hardware platform that is provided, you may devote your attention to the development of your application. In this chapter, learn the basics about the embedded computer hardware and its different parts.

This chapter covers the following topics:

- ❑ **Appearance**
 - ThinkCore W311
 - ThinkCore W321
 - ThinkCore W341
- ❑ **Dimensions**
 - ThinkCore W311
 - ThinkCore W321
 - ThinkCore W341
- ❑ **LED Indicators**
- ❑ **Reset Button**
- ❑ **Real Time Clock**

Appearance

ThinkCore W311

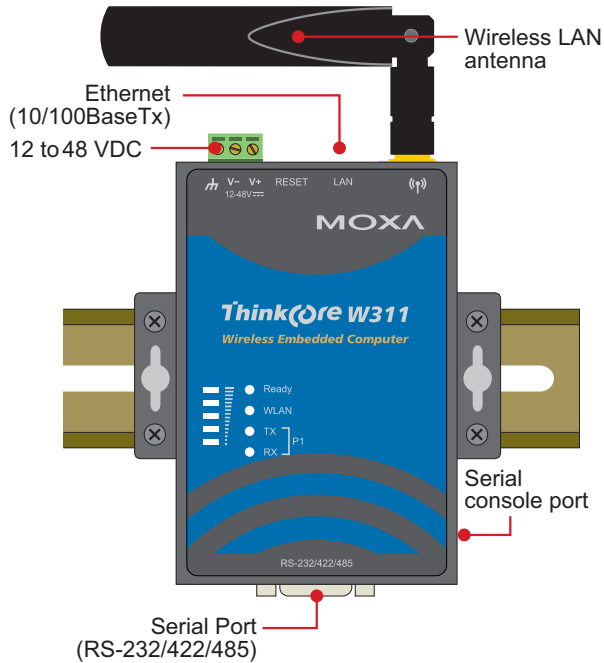

ThinkCore W321

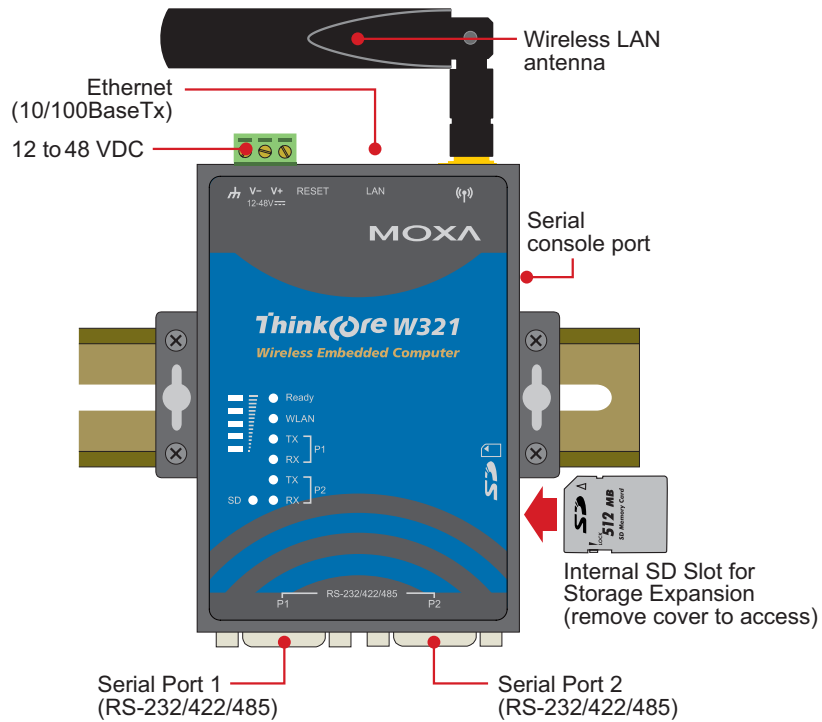

ThinkCore W341

Top View

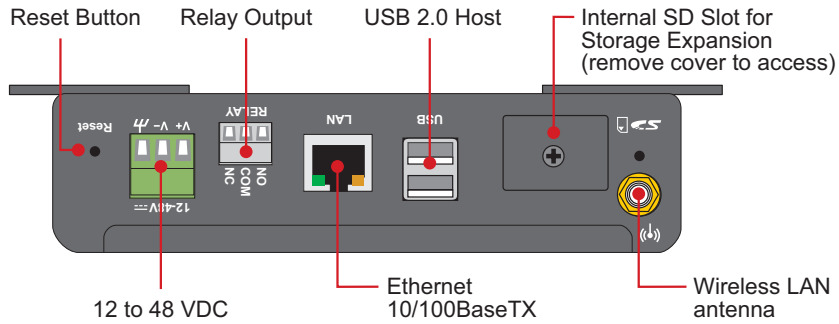

Front View

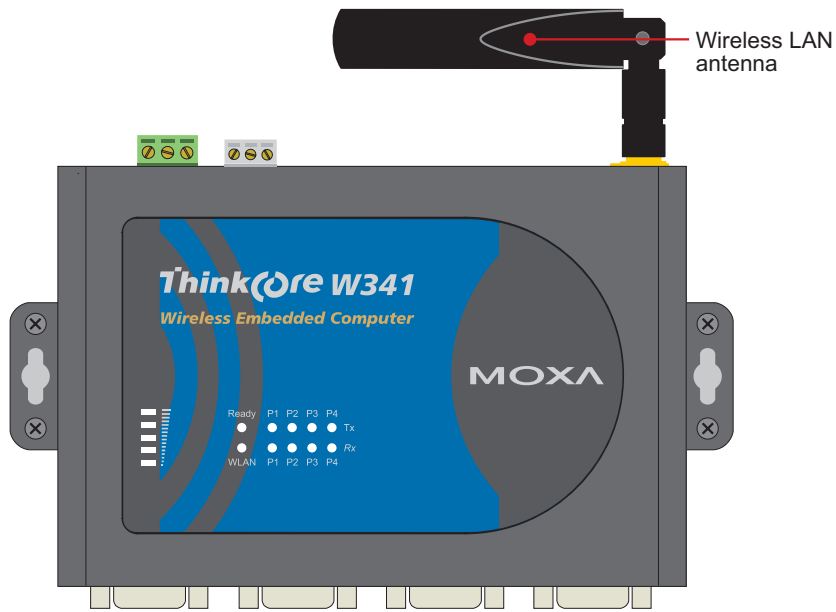

Bottom View

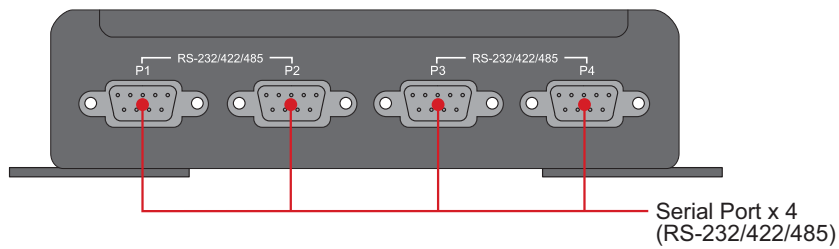

Dimensions

ThinkCore W311

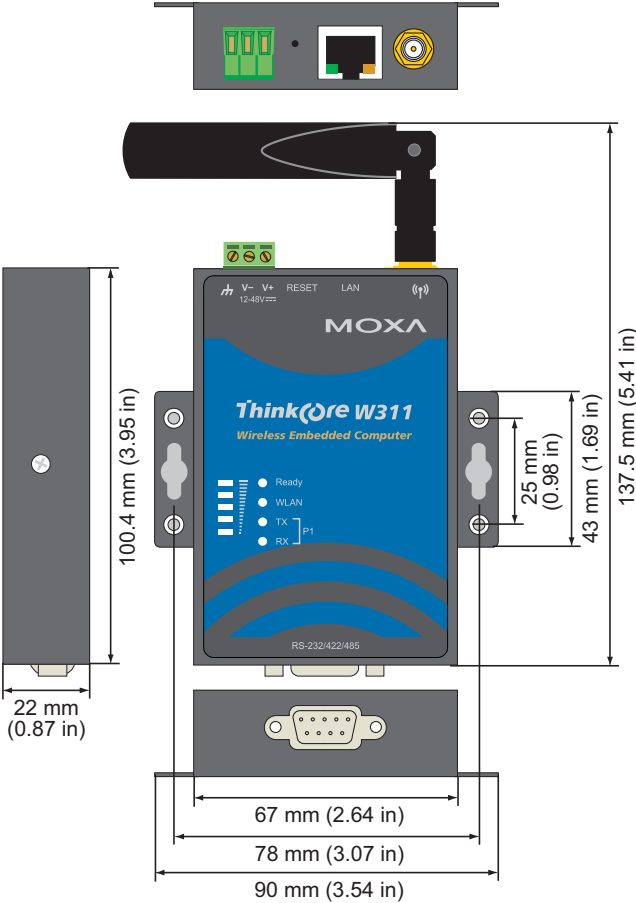

ThinkCore W321

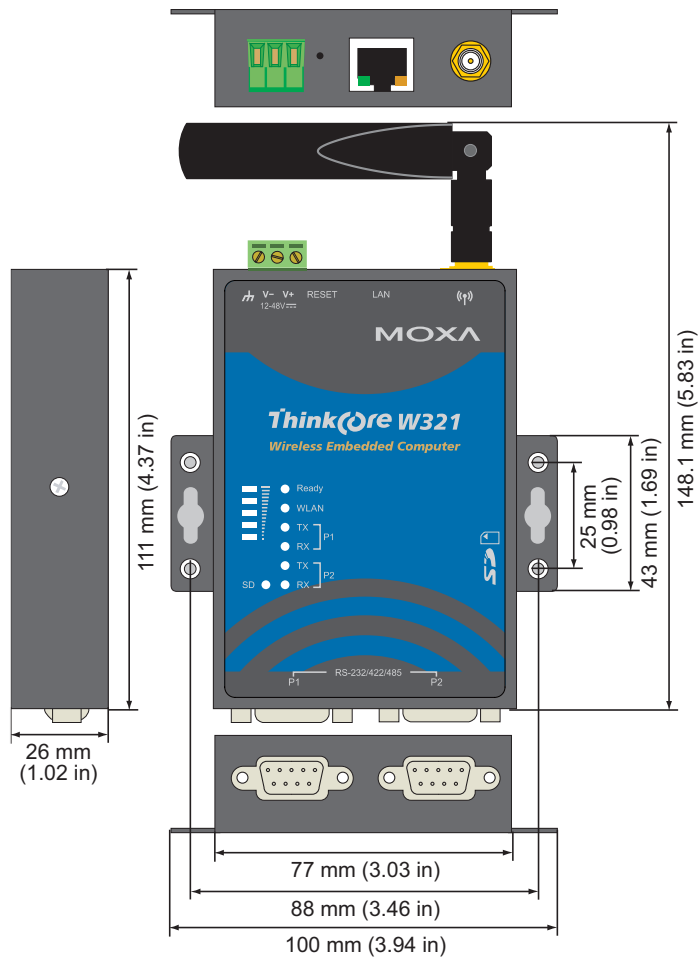

ThinkCore W341

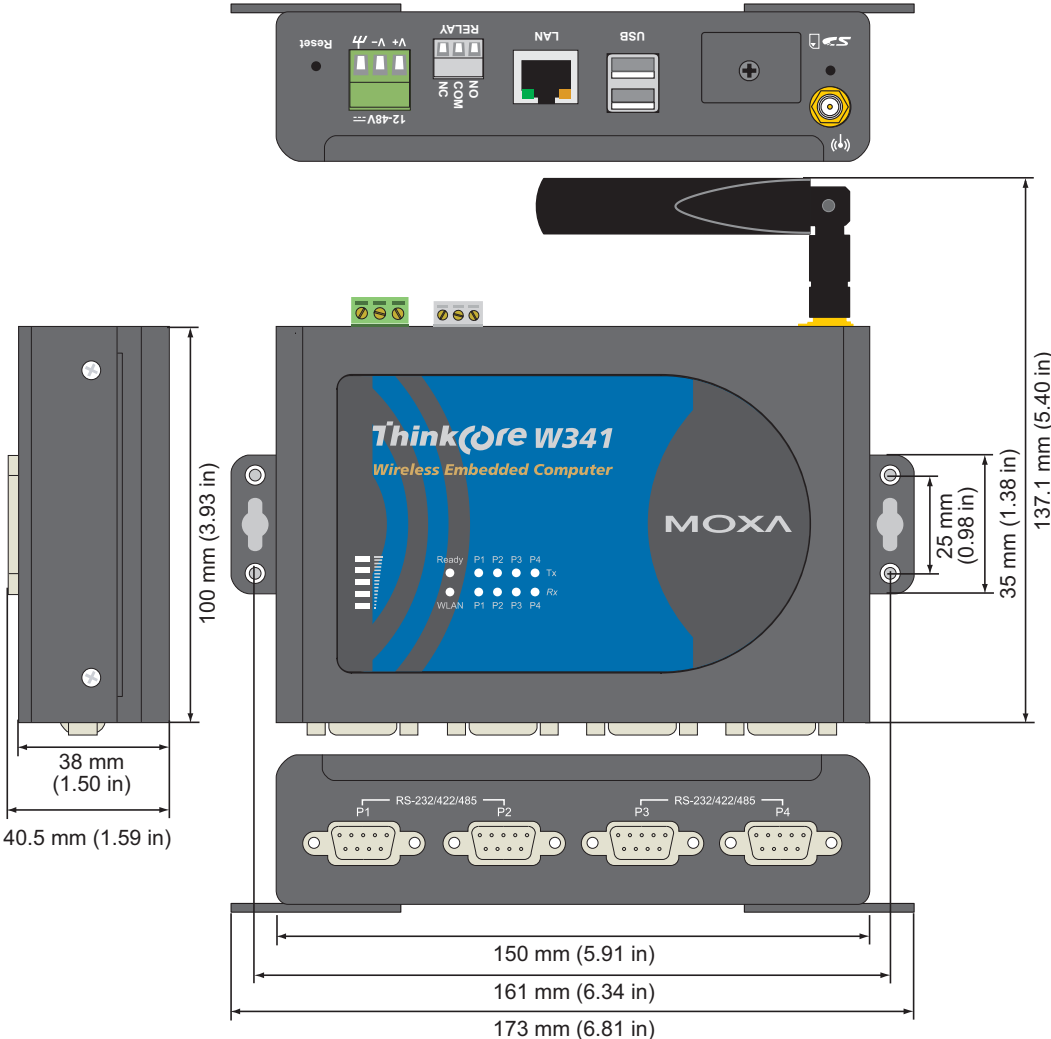

LED Indicators

Please note that the W311 does not include an SD slot, so it will not have an SD LED.

LED Name	LED Color	LED Function
Ready	Green	Power is on and functioning normally
	Off	Power is off or there is another power error
SD	Green	SD card is detected
	Off	No SD card is detected
WLAN	Green	ON: WLAN is ready
		Blinking: Conflict with WLAN IP or no response from DHCP server
	Off	WLAN is not ready or function error
Signal Strength	Green	Number of glowing LEDs indicates signal strength 5: Excellent 4: Very good 3: Good 2: Fair 1: Bad
		Off
LAN	Orange	10 Mbps Ethernet link
	Green	100 Mbps Ethernet link
	Off	Disconnected or short circuit
TxD P1-P4	Green	Serial ports P1-P4 transmitting data
	Off	Serial ports P1-P4 not transmitting data
RxD P1-P4	Yellow	Serial ports P1-P4 receiving data
	Off	Serial ports P1-P4 not receiving data

Reset Button

Hold the reset button down for 5 seconds to load the factory default configuration. After loading the factory defaults, the system will reboot automatically. We recommend that you use this function only if the software is not working properly. To reset the Linux system software, always use the software reboot command (“reboot”) to protect the integrity of data.

The reset button is NOT designed as a hard reboot for the embedded computer.



ATTENTION

Restoring default settings preserves your data

Resetting the embedded computer to factory defaults will NOT format the user directory and will NOT erase the user's data. The reset button only loads a configuration file. All files in the `/etc` directory will revert to their factory defaults, but all other user data will remain intact in the Flash ROM.

Please note that if there is a problem with the `/etc` directory, the embedded computer may be unable to restore the factory default settings.

Real Time Clock

The embedded computer's real-time clock is powered by a lithium battery. We strongly recommend that you NOT replace the lithium battery on your own. If the battery needs to be changed, please contact the MOXA RMA service team.



ATTENTION

There is a risk of explosion if the wrong type of battery is used. To avoid this potential danger, always be sure to use the correct type of battery. Contact the MOXA RMA service team for battery replacement.

Hardware Connection Description

ThinkCore W300 Series wireless embedded computers are equipped for multiple types of connections. WLAN, Ethernet, and multiple serial interfaces are built into every model, including a serial console port for monitoring of bootup messages. Select models also include an SD slot for storage expansion, USB ports for additional device and storage options, and relay output connections. With the open-source Linux kernel, you are free to develop custom applications for remote, wireless operation of your device. In this chapter, learn how to connect the embedded computer to the network and to various devices.

This chapter covers the following topics:

- ❑ **Wiring Requirements**
 - Connecting the Power
 - Grounding the Unit
- ❑ **Connecting Data Transmission Cables**
 - Connecting to the Network
 - Connecting to the WLAN
 - Connecting to a Serial Device
 - Serial Console Port
- ❑ **SD Slot (W321 and W341 only)**
- ❑ **USB (W341 only)**
- ❑ **Relay Output (W341 only)**

Wiring Requirements

This section describes how to connect serial devices to the embedded computer.

You should heed the following common safety precautions before proceeding with the installation of any electronic device:

- Use separate paths to route wiring for power and devices. If power wiring and device wiring paths must cross, make sure the wires are perpendicular at the intersection point.

NOTE: Do not run signal or communication wiring and power wiring in the same wire conduit. To avoid interference, wires with different signal characteristics should be routed separately.

- Use the type of signal transmitted through a wire to determine which wires should be kept separate. The rule of thumb is that wiring that shares similar electrical characteristics can be bundled together.
- Keep input wiring and output wiring separate.
- It is advisable to label the wiring to all devices in the system.



ATTENTION

Safety First!

Be sure to disconnect the power cord before installation and/or wiring.

Watch Electrical Current!

Calculate the maximum possible current in each power wire and common wire. Observe all electrical codes dictating the maximum current allowable for each wire size.

If the current goes above the maximum ratings, the wiring could overheat, causing serious damage to your equipment.

Watch Temperature!

Be careful when handling the unit. When the unit is plugged in, the internal components generate heat, and consequently the outer casing may feel hot to the touch.

Connecting the Power

Connect the “live-wire” end of the 12-48 VDC power adapter to the embedded computer’s terminal block. When power is properly supplied, the “Ready” LED will glow a solid green after a 25 to 30 second delay.

Grounding the Unit

Grounding and wire routing help limit the effects of noise due to electromagnetic interference (EMI). Before connecting any devices, run a ground wire from the ground screw to the grounding surface.



ATTENTION

This product should be mounted to a well-grounded mounting surface such as a metal panel.

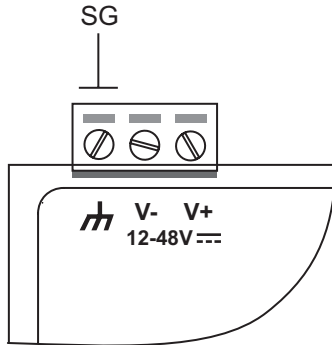

SG: The *Shielded Ground* (sometimes called Protected Ground) contact is the left most contact of the 3-pin power terminal block connector, as viewed from the angle shown here. Connect the SG wire to an appropriate grounded metal surface.

Connecting Data Transmission Cables

This section describes how to connect cables for the network, serial devices, and serial COM terminal.

Connecting to the Network

Plug your network cable into the embedded computer's Ethernet port. The other end of the cable should be plugged into your Ethernet network. When the cable is properly connected, the LEDs on the embedded computer's Ethernet port will glow to indicate a valid connection.

The 10/100 Mbps Ethernet LAN port uses 8-pin RJ45 connectors. The following diagram shows the pinouts for these ports.

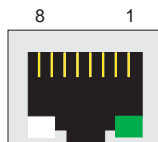

The LED indicator in the lower right corner glows a solid green color when the cable is properly connected to a 100 Mbps Ethernet network. The LED will flash on and off when Ethernet packets are being transmitted or received.

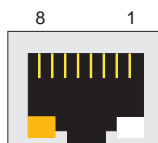

The LED indicator in the lower left corner glows a solid orange color when the cable is properly connected to a 10 Mbps Ethernet network. The LED will flash on and off when Ethernet packets are being transmitted or received.

Pin	Signal
1	ETx+
2	ETx-
3	ERx+
4	---
5	---
6	ERx-
7	---
8	---

Connecting to the WLAN

The wireless embedded computer is WLAN ready and includes an 802.11 a/b/g WLAN module. It supports WEP, WPA and WPA2 data encryption. To verify WLAN operation, first configure your WLAN settings on the embedded computer using the serial console or a wired network connection. Please refer to the operating system user's manual for further detail.

Connecting to a Serial Device

Your serial device can plug into the embedded computer's serial port using a serial cable. Serial ports P1 to P4 have male DB9 connectors and can be configured for RS-232, RS-422, or RS-485 communication through software. The pin assignments are shown in the following table:

DB9 Male Port

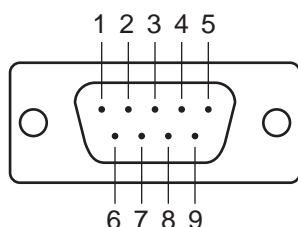

RS-232/422/485 Pinouts

Pin	RS-232	RS-422	RS-485 (4-wire)	RS-485 (2-wire)
1	DCD	TxDA(-)	TxDA(-)	---
2	RxD	TxDB(+)	TxDB(+)	---
3	TxD	RxDB(+)	RxDB(+)	DataB(+)
4	DTR	RxDA(-)	RxDA(-)	DataA(-)
5	GND	GND	GND	GND
6	DSR	---	---	---
7	RTS	---	---	---
8	CTS	---	---	---

Serial Console Port

The serial console port is a 4-pin pin-header RS-232 port. It is designed for serial console terminals, which are useful for viewing boot-up messages.

Serial Console Port & Pinouts

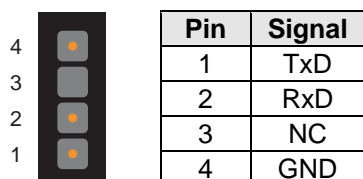

Serial Console Cable



SD Slot (W321 and W341 only)

Both the ThinkCore W321 and W341 include an SD slot for storage expansion. The SD slot allows users to add up to 1 GB of additional memory by inserting a Secure Digital (SD) memory card compliant with the SD 1.0 standard.

To install an SD card, remove the cover in order to access the slot. Insert the SD card into the slot and push it in until it clicks. To remove the card, push the card in until it clicks to release, then pull the card out.



USB (W341 only)

The ThinkCore W341 includes two USB 2.0 hosts. These hosts can be used for an external flash disk or hard drive in order to store large amounts of data.

Relay Output (W341 only)

The ThinkCore W341 includes a relay output channel. There is a 3-pin terminal block for the relay output connection, with pinouts as shown in the figure.

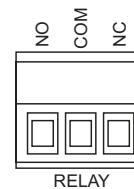

A

FCC Warning Statement

This device complies with Part 15 of the FCC Rules. Operation is subject to the following two conditions:

1. this device may not cause harmful interference, and
2. this device must accept any interference received, including interference that may cause undesired operation.

This equipment has been tested and found to comply with the limits for a class B digital device, pursuant to part 15 of the FCC Rules. These limits are designed to provide reasonable protection against harmful interference in a residential installation.

This equipment generates, uses, and can radiate radio frequency energy, and if not installed and used in accordance with the instructions, may cause harmful interference to radio communications. However, there is no guarantee that interference will not occur in a particular installation. If this equipment does cause harmful interference to radio or television reception, which can be determined by turning the equipment off and on, the user is encouraged to try to correct the interference by one or more of the following measures:

- Reorient or relocate the receiving antenna.
- Increase the separation between the equipment and receiver.
- Connect the equipment into an outlet on a circuit different from that to which the receiver is connected.
- Consult the dealer or an experienced radio/TV technician for help.

CAUTION:

Any changes or modifications not expressly approved by the party responsible for compliance could void the user's authority to operate the equipment.

Prohibition of co-location

This device and its antenna(s) must not be co-located or operating in conjunction with any other antenna or transmitter.

Safety Information

To maintain compliance with FCC's RF exposure guidelines, when installing and/or operating this equipment, you should maintain a minimum distance of 20 cm between the transmitter and your body. Use only the supplied antenna. Unauthorized antennae, modifications, or attachments could damage the transmitter and may violate FCC regulations.

B

Service Information

This appendix shows you how to contact MOXA for information about this and other products, and how to report problems.

The following topics are covered in this appendix:

- MOXA Internet Services**
- Problem Report Form**
- Product Return Procedure**

MOXA Internet Services

Customer satisfaction is our number one concern, and to ensure that customers receive the full benefit of our products, MOXA Internet Services has been set up to provide technical support, driver updates, product information, and user's manual updates.

The following services are provided

E-mail for technical support.....support@moxa.com

World Wide Web (WWW) Site for product information:

.....<http://www.moxa.com>

Product Return Procedure

For product repair, exchange, or refund, the customer must:

- ◆ Provide evidence of original purchase.
- ◆ Obtain a Product Return Agreement (PRA) from the sales representative or dealer.
- ◆ Fill out the Problem Report Form (PRF). Include as much detail as possible for a shorter product repair time.
- ◆ Carefully pack the product in an anti-static package, and send it, pre-paid, to the dealer. The PRA should be visible on the outside of the package, and include a description of the problem, along with the return address and telephone number of a technical contact.