



# 5500 Master Series

MS-96C8 (V1.X) Server Board



G52-96C81X1

## Copyright Notice

---

The material in this document is the intellectual property of **MICRO-STAR INTERNATIONAL**. We take every care in the preparation of this document, but no guarantee is given as to the correctness of its contents. Our products are under continual improvement and we reserve the right to make changes without notice.

## Trademarks

---

All trademarks are the properties of their respective owners.

NVIDIA, the NVIDIA logo, DualNet, and nForce are registered trademarks or trademarks of NVIDIA Corporation in the United States and/or other countries.

AMD, Athlon™, Athlon™ XP, Thoroughbred™, and Duron™ are registered trademarks of AMD Corporation.

Intel® and Pentium® are registered trademarks of Intel Corporation.

PS/2 and OS®/2 are registered trademarks of International Business Machines Corporation.

Windows® 98/2000/NT/XP/Vista are registered trademarks of Microsoft Corporation.

Netware® is a registered trademark of Novell, Inc.

Award® is a registered trademark of Phoenix Technologies Ltd.

AMI® is a registered trademark of American Megatrends Inc.

## Revision History

---

Revision	Revision History	Date
V1.0	First release	April 2009

## Technical Support

---

If a problem arises with your system and no solution can be obtained from the user's manual, please contact your place of purchase or local distributor. Alternatively, please try the following help resources for further guidance.

- ▶ Visit the MSI website for FAQ, technical guide, BIOS updates, driver updates and other information: <http://www.msi.com/index.php?func=service>
- ▶ Contact our technical staff at: <http://ocss.msi.com>

## Safety Instructions

---

1. Always read the safety instructions carefully.
2. Keep this User's Manual for future reference.
3. Keep this equipment away from humidity.
4. Lay this equipment on a reliable flat surface before setting it up.
5. The openings on the enclosure are for air convection hence protects the equipment from overheating. **DO NOT COVER THE OPENINGS.**
6. Make sure the voltage of the power source and adjust properly 110/220V before connecting the equipment to the power inlet.
7. Place the power cord such a way that people can not step on it. Do not place anything over the power cord.
8. Always Unplug the Power Cord before inserting any add-on card or module.
9. All cautions and warnings on the equipment should be noted.
10. Never pour any liquid into the opening that could damage or cause electrical shock.
11. If any of the following situations arises, get the equipment checked by service personnel:
  - ▶ The power cord or plug is damaged.
  - ▶ Liquid has penetrated into the equipment.
  - ▶ The equipment has been exposed to moisture.
  - ▶ The equipment does not work well or you can not get it work according to User's Manual.
  - ▶ The equipment has dropped and damaged.
  - ▶ The equipment has obvious sign of breakage.
12. **DO NOT LEAVE THIS EQUIPMENT IN AN ENVIRONMENT UNCONDITIONED, STORAGE TEMPERATURE ABOVE 60°C (140°F), IT MAY DAMAGE THE EQUIPMENT.**



此为 **A 级** 产品，在生活环境中，该产品可能会造成无线电干扰。  
在这种情况下，可能需要用户对其干扰采取切实可行的措施。



警告使用者：

此为甲类资讯技术设备，於居住环境中使用时，可能会造成射频干扰，在此情况下，使用者会被要求采取某些适当的对策



**CAUTION:** Danger of explosion if battery is incorrectly replaced. Replace only with the same or equivalent type recommended by the manufacturer.



廢電池請回收

For better environmental protection, waste batteries should be collected separately for recycling or special disposal.

## FCC-B Radio Frequency Interference Statement

---

This equipment has been tested and found to comply with the limits for a Class B digital device, pursuant to Part



15 of the FCC Rules. These limits are designed to provide reasonable protection against harmful interference in a residential installation. This equipment generates, uses and can radiate radio frequency energy and, if not installed and used in accordance with the instructions, may cause harmful interference to radio communications. However, there is no guarantee that interference will not occur in a particular installation. If this equipment does cause harmful interference to radio or television reception, which can be determined by turning the equipment off and on, the user is encouraged to try to correct the interference by one or more of the measures listed below.

- Reorient or relocate the receiving antenna.
- Increase the separation between the equipment and receiver.
- Connect the equipment into an outlet on a circuit different from that to which the receiver is connected.
- Consult the dealer or an experienced radio/television technician for help.

### Notice 1

The changes or modifications not expressly approved by the party responsible for compliance could void the user's authority to operate the equipment.

### Notice 2

Shielded interface cables and A.C. power cord, if any, must be used in order to comply with the emission limits.

VOIR LANOTICE D'INSTALLATIONAVANT DE RACCORDER AU RESEAU.



*This device complies with Part 15 of the FCC Rules. Operation is subject to the following two conditions:*

- (1) this device may not cause harmful interference, and*
- (2) this device must accept any interference received, including interference that may cause undesired operation.*

# WEEE (Waste Electrical and Electronic Equipment) Statement

---

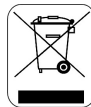

## ENGLISH

To protect the global environment and as an environmentalist, MSI must remind you that...

Under the European Union ("EU") Directive on Waste Electrical and Electronic Equipment, Directive 2002/96/EC, which takes effect on August 13, 2005, products of "electrical and electronic equipment" cannot be discarded as municipal waste anymore and manufacturers of covered electronic equipment will be obligated to take back such products at the end of their useful life. MSI will comply with the product take back requirements at the end of life of MSI-branded products that are sold into the EU. You can return these products to local collection points.

## DEUTSCH

Hinweis von MSI zur Erhaltung und Schutz unserer Umwelt

Gemäß der Richtlinie 2002/96/EG über Elektro- und Elektronik-Altgeräte dürfen Elektro- und Elektronik-Altgeräte nicht mehr als kommunale Abfälle entsorgt werden. MSI hat europaweit verschiedene Sammel- und Recyclingunternehmen beauftragt, die in die Europäische Union in Verkehr gebrachten Produkte, am Ende seines Lebenszyklus zurückzunehmen. Bitte entsorgen Sie dieses Produkt zum gegebenen Zeitpunkt ausschliesslich an einer lokalen Altgerätesammelstelle in Ihrer Nähe.

## FRANÇAIS

En tant qu'écologiste et afin de protéger l'environnement, MSI tient à rappeler ceci...

Au sujet de la directive européenne (EU) relative aux déchets des équipement électriques et électroniques, directive 2002/96/EC, prenant effet le 13 août 2005, que les produits électriques et électroniques ne peuvent être déposés dans les décharges ou tout simplement mis à la poubelle. Les fabricants de ces équipements seront obligés de récupérer certains produits en fin de vie. MSI prendra en compte cette exigence relative au retour des produits en fin de vie au sein de la communauté européenne. Par conséquent vous pouvez retourner localement ces matériels dans les points de collecte.

## РУССКИЙ

Компания MSI предпринимает активные действия по защите окружающей среды, поэтому напоминаем вам, что...

В соответствии с директивой Европейского Союза (ЕС) по предотвращению загрязнения окружающей среды использованным электрическим и электронным оборудованием (директива WEEE 2002/96/EC), вступающей в силу 13 августа 2005 года, изделия, относящиеся к электрическому и электронному оборудованию, не могут рассматриваться как бытовой мусор, поэтому производители вышеперечисленного электронного оборудования обязаны принимать его для переработки по окончании срока службы. MSI обязуется соблюдать требования по приему продукции, проданной под маркой MSI на территории ЕС, в переработку по окончании срока службы. Вы можете вернуть эти изделия в специализированные пункты приема.

## **ESPAÑOL**

MSI como empresa comprometida con la protección del medio ambiente, recomienda:

Bajo la directiva 2002/96/EC de la Unión Europea en materia de desechos y/o equipos electrónicos, con fecha de rigor desde el 13 de agosto de 2005, los productos clasificados como "eléctricos y equipos electrónicos" no pueden ser depositados en los contenedores habituales de su municipio, los fabricantes de equipos electrónicos, están obligados a hacerse cargo de dichos productos al término de su período de vida. MSI estará comprometido con los términos de recogida de sus productos vendidos en la Unión Europea al final de su período de vida. Usted debe depositar estos productos en el punto limpio establecido por el ayuntamiento de su localidad o entregar a una empresa autorizada para la recogida de estos residuos.

## **NEDERLANDS**

Om het milieu te beschermen, wil MSI u eraan herinneren dat....

De richtlijn van de Europese Unie (EU) met betrekking tot Vervuiling van Elektrische en Electronische producten (2002/96/EC), die op 13 Augustus 2005 in zal gaan kunnen niet meer beschouwd worden als vervuiling.

Fabrikanten van dit soort producten worden verplicht om producten retour te nemen aan het eind van hun levenscyclus. MSI zal overeenkomstig de richtlijn handelen voor de producten die de merknaam MSI dragen en verkocht zijn in de EU. Deze goederen kunnen geretourneerd worden op lokale inzamelingspunten.

## **SRPSKI**

Da bi zaštitili prirodnu sredinu, i kao preduzeće koje vodi računa o okolini i prirodnoj sredini, MSI mora da vas podestiti da...

Po Direktivi Evropske unije ("EU") o odbačenju elektonskoj i električnoj opremi, Direktiva 2002/96/EC, koja stupa na snagu od 13. Avgusta 2005, proizvodi koji spadaju pod "elektronsku i električnu opremu" ne mogu više biti odbačeni kao običan otpad i proizvođači ove opreme biće prinudeni da uzmu natrag ove proizvode na kraju njihovog uobičajenog veka trajanja. MSI će poštovati zahtev o preuzimanju ovakvih proizvoda kojima je istekao vek trajanja, koji imaju MSI oznaku i koji su prodati u EU. Ove proizvode možete vratiti na lokalnim mestima za prikupljanje.

## **POLSKI**

Aby chronić nasze środowisko naturalne oraz jako firma dbająca o ekologię, MSI przypomina, że...

Zgodnie z Dyrektywą Unii Europejskiej ("UE") dotyczącą odpadów produktów elektrycznych i elektronicznych (Dyrektywa 2002/96/EC), która wchodzi w życie 13 sierpnia 2005, tzw. "produkty oraz wyposażenie elektryczne i elektroniczne" nie mogą być traktowane jako śmieć komunalne, tak więc producenci tych produktów będą zobowiązani do odbierania ich w momencie gdy produkt jest wycofywany z użycia. MSI wypełni wymagania UE, przyjmując produkty (sprzedawane na terenie Unii Europejskiej) wycofywane z użycia. Produkty MSI będzie można zwracać w wyznaczonych punktach zbiorczych.

## TÜRKÇE

Çevreci özelliğiyle bilinen MSI dünyada çevreyi korumak için hatırlatır:

Avrupa Birliği (AB) Kararnamesi Elektrik ve Elektronik Malzeme Atığı, 2002/96/EC Kararnamesi altında 13 Ağustos 2005 tarihinden itibaren geçerli olmak üzere, elektrikli ve elektronik malzemeler diğer atıklar gibi çöpe atılmayacak ve bu elektronik cihazların üreticileri, cihazların kullanım süreleri bittikten sonra ürünleri geri toplamakla yükümlü olacaktır. Avrupa Birliği'ne satılan MSI markalı ürünlerin kullanım süreleri bittiğinde MSI ürünlerin geri alınması isteği ile işbirliği içerisinde olacaktır. Ürünlerinizi yerel toplama noktalarına bırakabilirsiniz.

## ČESKY

Záleží nám na ochraně životního prostředí - společnost MSI upozorňuje...

Podle směrnice Evropské unie ("EU") o likvidaci elektrických a elektronických výrobků 2002/96/EC platné od 13. srpna 2005 je zakázáno likvidovat "elektrické a elektronické výrobky" v běžném komunálním odpadu a výrobci elektronických výrobků, na které se tato směrnice vztahuje, budou povinni odebírat takové výrobky zpět po skončení jejich životnosti. Společnost MSI splní požadavky na odebrání výrobků značky MSI, prodávaných v zemích EU, po skončení jejich životnosti. Tyto výrobky můžete odevzdat v místních sběrnách.

## MAGYAR

Annak érdekében, hogy környezetünket megvédjük, illetve környezetvédőként fellépve az MSI emlékezteti Önt, hogy ...

Az Európai Unió („EU”) 2005. augusztus 13-án hatályba lépő, az elektromos és elektronikus berendezések hulladékairól szóló 2002/96/EK irányelve szerint az elektromos és elektronikus berendezések többé nem kezelhetők lakossági hulladékként, és az ilyen elektronikus berendezések gyártói kötelessé válnak az ilyen termékek visszavételére azok hasznos élettartama végén. Az MSI betartja a termék visszavétellel kapcsolatos követelményeket az MSI márkánév alatt az EU-n belül értékesített termékek esetében, azok élettartamának végén. Az ilyen termékeket a legközelebbi gyűjtőhelyre viheti.

## ITALIANO

Per proteggere l'ambiente, MSI, da sempre amica della natura, ti ricorda che....

In base alla Direttiva dell'Unione Europea (EU) sullo Smaltimento dei Materiali Elettrici ed Elettronici, Direttiva 2002/96/EC in vigore dal 13 Agosto 2005, prodotti appartenenti alla categoria dei Materiali Elettrici ed Elettronici non possono più essere eliminati come rifiuti municipali: i produttori di detti materiali saranno obbligati a ritirare ogni prodotto alla fine del suo ciclo di vita. MSI si adegnerà a tale Direttiva ritirando tutti i prodotti marchiati MSI che sono stati venduti all'interno dell'Unione Europea alla fine del loro ciclo di vita. È possibile portare i prodotti nel più vicino punto di raccolta.

# CONTENTS

Copyright Notice .....	ii
Trademarks .....	ii
Revision History .....	ii
Technical Support .....	ii
Safety Instructions .....	iii
FCC-B Radio Frequency Interference Statement .....	iv
WEEE (Waste Electrical and Electronic Equipment) Statement .....	v
<b>Chapter 1 Getting Started .....</b>	<b>1-1</b>
Mainboard Specifications .....	1-2
Mainboard Layout .....	1-4
<b>Chapter 2 Hardware Setup .....</b>	<b>2-1</b>
Quick Components Guide .....	2-2
CPU (Central Processing Unit) .....	2-3
Memory .....	2-7
Power Supply .....	2-8
Back Panel I/O .....	2-9
Connector .....	2-10
Jumper .....	2-17
Slot .....	2-18
<b>Chapter 3 BIOS Setup .....</b>	<b>3-1</b>
Entering Setup .....	3-2
The Menu Bar .....	3-4
Main .....	3-5
Advanced .....	3-6
Boot .....	3-20
Security .....	3-24
Chipset .....	3-25
Exit .....	3-29
<b>Appendix A Intel ICH10R SATA RAID .....</b>	<b>A-1</b>
Introduction .....	A-2
BIOS Configuration .....	A-3
Installing Driver .....	A-10
Installing Software .....	A-12
RAID Migration Instructions .....	A-16
Recovery Volume Creation .....	A-23
Degraded RAID Array .....	A-27

<b>Appendix B LSI SAS RAID .....</b>	<b>B-1</b>
1. Introduction to Integrated RAID .....	B-2
2. Integrated Mirroring Overview .....	B-3
3. Creating Integrated Mirroring Volumes .....	B-9
4. Integrated Striping Overview .....	B-16
5. Creating Integrated Striping Volumes .....	B-19

*This page is intentionally left blank.*

# Chapter 1

## Getting Started

Thank you for choosing the 5500 Master Series (MS-96C8 V1.X), an excellent server board from MSI.

Based on the innovative **Intel® 5500 & ICH10R** chipsets for optimal system efficiency, the 5500 Master Series accommodate the latest 45nm Intel® Nehalem processor (**up to 95W**) in LGA1366 package and support up to 6 DDR3 800/1066/1333 DIMM slots to provide the maximum of 48GB memory capacity.

In the advanced-level and mid-range market segment, the 5500 Master Series can provide a high-performance solution for today's front-end and general purpose server, as well as in the future.



## Mainboard Specifications

<b>Processor</b>
- 45nm Intel Nehalem processor ( <i>up to 95W</i> ) in LGA1366 package
<b>Supported QPI</b>
- Up to 6.4 GT/s
<b>Chipset</b>
- North Bridge: Intel 5500 chipset - South Bridge: Intel ICH10R chipset
<b>Memory</b>
- 6 DDR3 800/1066/1333 DIMM slots - Supports the maximum of 48GB RDIMM or 24GB UDIMM
<b>LAN</b>
- Supports Gb LAN by Intel 82574 & 82567 Gb Ethernet controller
<b>IDE</b>
- 1 IDE port by ITE IT8213F - Supports Ultra DMA 66/100/133 mode - Supports PIO, Bus Master operation mode
<b>SATA</b>
- 6 SATAII ports by Intel ICH10R - Supports 6 SATAII devices - Supports up to 3Gb/s data transfer rate
<b>SAS</b>
- 2 mini SAS ports by LSI Logic SAS1068E Host Controller - Data transfer rate at up to 3Gb/s
<b>Graphics</b>
- Aspeed AST1100 (default)/ AST2050 (optional) graphics controller
<b>Server Management</b>
- Aspeed AST1100 (default)/ AST2050 (optional) BMC controller with IPMI 2.0/1.5 compliance

## Onboard I/O

### ► Back Panel

- 1 PS/2 mouse port
- 1 PS/2 keyboard port
- 2 USB 2.0 ports
- 1 serial port
- 1 D-Sub VGA port
- 2 RJ-45 LAN jacks

### ► Onboard Connectors

- 2 USB 2.0 pinheaders (4 ports)
- 1 serial port connector
- 1 SMBus connector
- 1 SPI Flash ROM pinheader (for debugging)
- 1 chassis intrusion connector
- 1 TPM connector

## Slot

- 1 PCI Express 2.0 x16 slot
- 1 PCI-Express 2.0 x8 slot
- 2 PCI-Express 2.0 x4 slots
- 1 32-bit/33MHz PCI slot

## Dimension

- 12" x 10.5" SSI CEB form factor

## Mounting

- 9 mounting holes

# Mainboard Layout

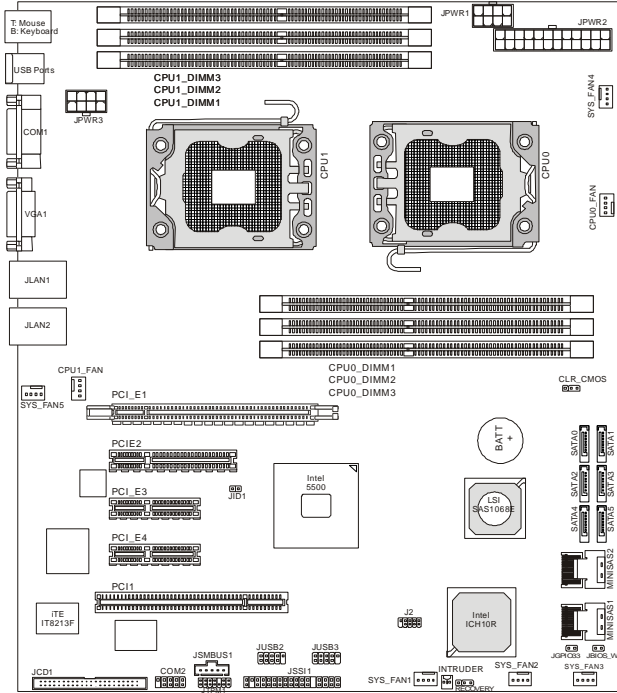

5500 Master Series (MS-96C8 V1.X) Server Board

## Chapter 2

# Hardware Setup

This chapter provides you with the information about hardware setup procedures. While doing the installation, be careful in holding the components and follow the installation procedures. For some components, if you install in the wrong orientation, the components will not work properly.

Use a grounded wrist strap before handling computer components. Static electricity may damage the components.



## Quick Components Guide

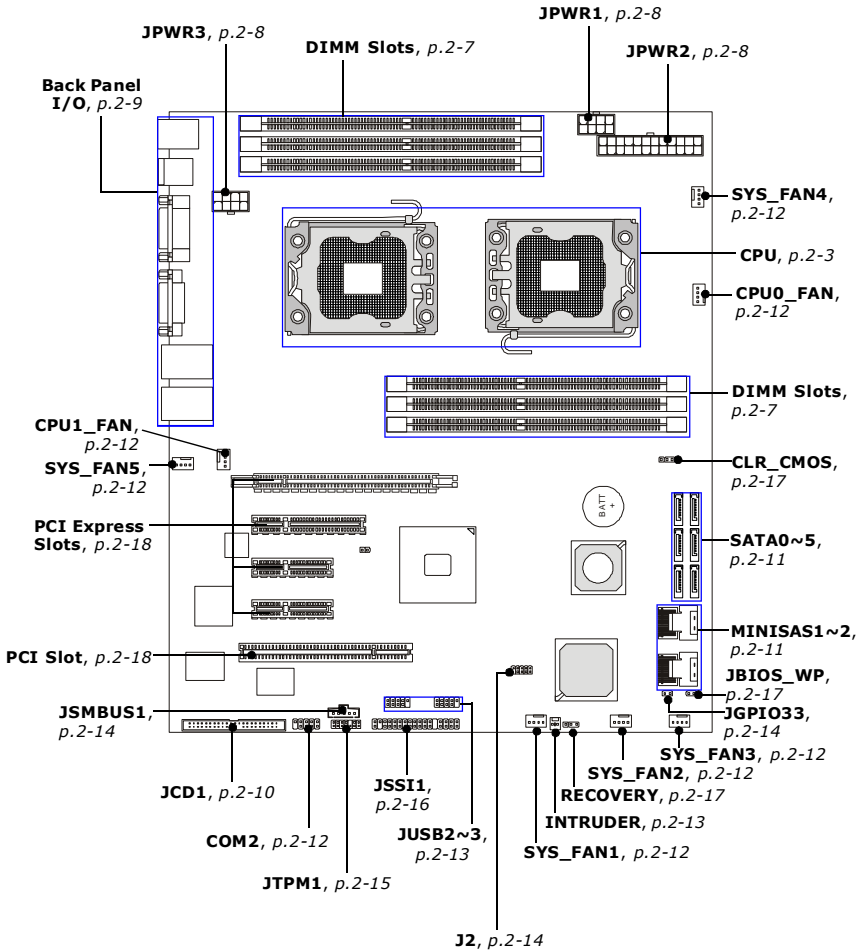

## CPU (Central Processing Unit)

When you are installing the CPU, **make sure that you install the cooler to prevent the CPU from overheating.** If you do not have the CPU cooler, consult your dealer before turning on the computer.



### Important

#### **Overheating**

*Overheating will seriously damage the CPU and system. Always make sure the cooling fan can work properly to protect the CPU from overheating. Make sure that you apply an even layer of thermal paste (or thermal tape) between the CPU and the heatsink to enhance heat dissipation.*

#### **Replacing the CPU**

*While replacing the CPU, always turn off the power supply or unplug the power supply's power cord from the grounded outlet first to ensure the safety of CPU.*

### Introduction to LGA 1366 CPU

The pin-pad side of LGA 1366 CPU.

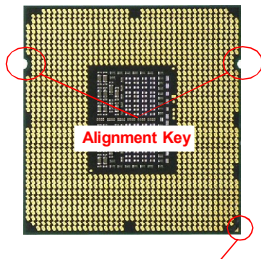

Yellow triangle is the Pin 1 indicator

The surface of LGA 1366 CPU. Remember to apply some thermal paste on it for better heat dispersion.

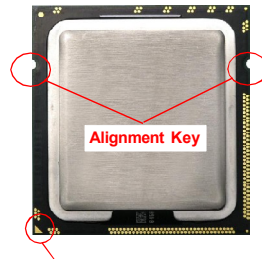

Yellow triangle is the Pin 1 indicator

## CPU & Cooler Installation

When you are installing the CPU, **make sure the CPU has a cooler attached on the top to prevent overheating.** Meanwhile, do not forget to apply some thermal paste on CPU before installing the heat sink/cooler fan for better heat dispersion. Follow the steps below to install the CPU & cooler correctly. Wrong installation will cause the damage of your CPU & mainboard.

1. Open the load level.

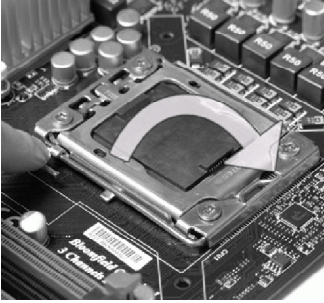

2. Lift the load lever up and open the load plate.

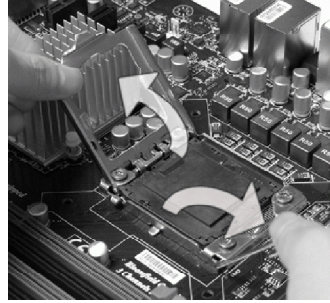

3. The CPU socket has a plastic cap on it to protect the contact from damage. Before you install CPU, always cover it to protect the socket pin. Remove the cap from the lever hinge side (as the arrow shows).

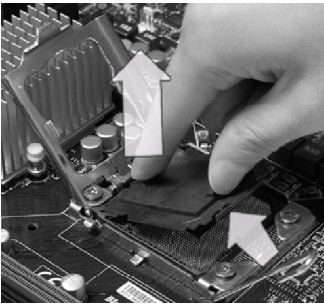

4. After confirming the CPU direction for correct mating, put down the CPU in the socket housing frame. Be sure to grasp on the edge of the CPU base. Note that the alignment keys are matched.

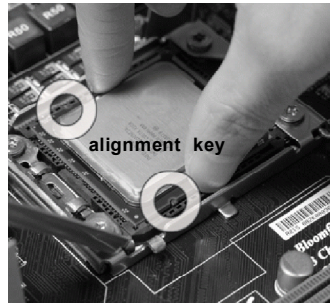

5. Visually inspect if the CPU is seated well into the socket. If not, take out the CPU with pure vertical motion and reinstall.

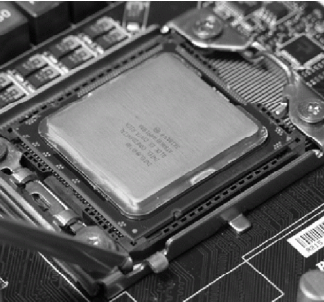

6. Cover the load plate onto the package.

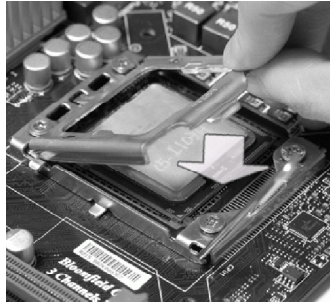

7. Press down the load lever lightly onto the load plate, and then secure the lever with the hook under retention tab.

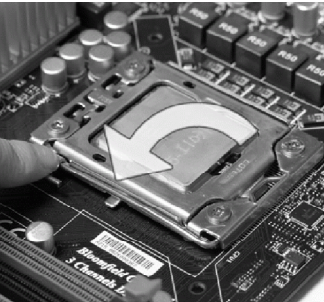

8. Align the holes on the mainboard with the heatsink. Push down the cooler until its four clips get wedged into the holes of the mainboard.

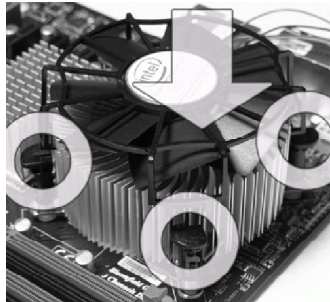

### Important

1. Confirm if your CPU cooler is firmly installed before turning on your system.
2. Do not touch the CPU socket pins to avoid damaging.

9. Align the holes on the mainboard with the heatsink. Push down the cooler until its four clips get wedged into the holes of the mainboard.

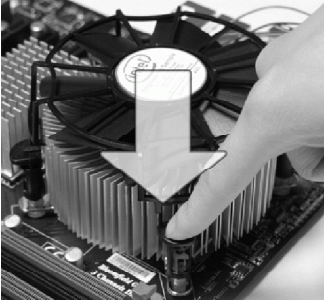

10. Turn over the mainboard to confirm that the clip-ends are correctly inserted.

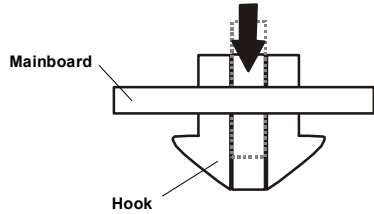

**Important**

1. Read the CPU status in BIOS.
2. Whenever CPU is not installed, always protect your CPU socket pin with the plastic cap covered (shown in Figure 1) to avoid damaging.
3. Mainboard photos shown in this section are for demonstration of the CPU/cooler installation only. The appearance of your mainboard may vary depending on the model you purchase.

## Memory

These DIMM slots are intended for system memory modules.

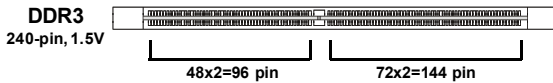

### Installing Memory Modules

1. Locate the DIMM slots on the mainboard. Flip open the retaining clip at each side of the DIMM slot.
2. Align the notch on the DIMM with the key on the slot. Insert the DIMM vertically into the DIMM slot. Then push it in until the golden finger on the DIMM is deeply inserted in the DIMM slot. The retaining clip at each side of the DIMM slot will automatically close if the DIMM is properly seated.



#### Important

*You can barely see the golden finger if the DIMM is properly inserted in the DIMM slot.*

3. Manually check if the DIMM has been locked in place by the retaining clips at the sides.
4. Follow the same procedures to install more DIMMs if necessary.

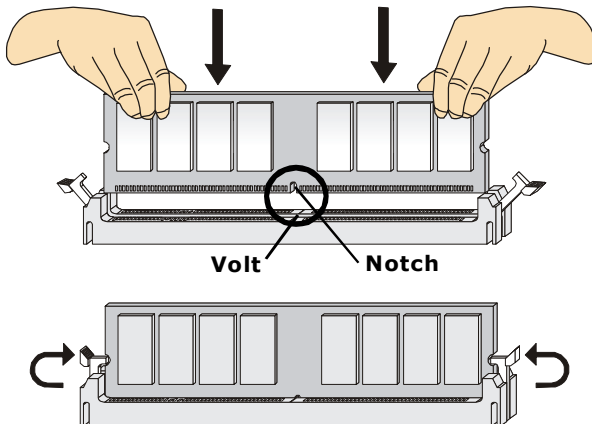

## Power Supply

### System Power Connector: JPWR2

This connector allows you to connect a power supply. To connect the power supply, make sure the plug of the power supply is inserted in the proper orientation and the pins are aligned. Then push down the power supply firmly into the connector.

### CPU/Memory Power Connector: JPWR1, JPWR3

These connectors provide 12V power output to the CPUs & memory.

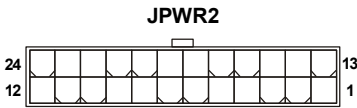

**JPWR2 Pin Definition**

PIN	SIGNAL	PIN	SIGNAL
1	+3.3V	13	+3.3V
2	+3.3V	14	-12V
3	GND	15	GND
4	+5V	16	PS-ON#
5	GND	17	GND
6	+5V	18	GND
7	GND	19	GND
8	PWROK	20	NC
9	+5VSB	21	+5V
10	+12V	22	+5V
11	+12V	23	+5V
12	+3.3V	24	GND

**JPWR1**

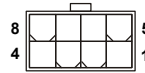

**JPWR1 Pin Definition**

PIN	SIGNAL	PIN	SIGNAL
1	GND	5	+12V
2	GND	6	+12V
3	GND	7	+12V
4	GND	8	+12V

**JPWR3**

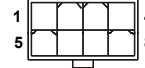

**JPWR3 Pin Definition**

PIN	SIGNAL	PIN	SIGNAL
1	GND	5	+12V
2	GND	6	+12V
3	GND	7	+12V
4	GND	8	+12V



### Important

1. Make sure that all power connectors are connected to the power supply to ensure stable operation of the mainboard.
2. Power supply of 600 watts (and above) is highly recommended for system stability.

## Back Panel I/O

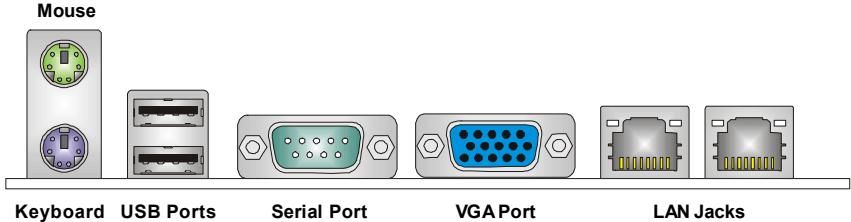

### ► Mouse/Keyboard

The standard PS/2® mouse/keyboard DIN connector is for a PS/2® mouse/keyboard.

### ► USB Port

The USB (Universal Serial Bus) port is for USB devices such as keyboard, mouse, or other USB-compatible devices.

### ► Serial Port

The serial port is a 16550A high speed communications port that sends/ receives 16 bytes FIFOs. You can attach a serial mouse or other serial devices directly to the connector.

### ► VGA Port

The DE-15 female connector is provided for monitor.

### ► LAN

The standard RJ-45 LAN jack is for connection to Local Area Network (LAN). You can connect a network cable to it.

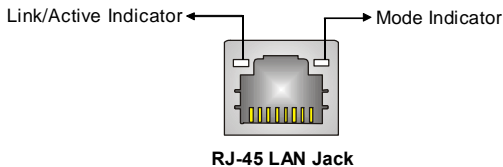

**RJ-45 LAN Jack**

LED	Color	LED State	Condition
Left	Orange	Off	LAN link is not established.
		On (steady state)	LAN link is established.
		On (brighter & pulsing)	The computer is communicating with another computer on the LAN.
Right	Green	Off	10 Mbit/sec data rate is selected.
	Green	On	100 Mbit/sec data rate is selected.
	Orange	On	1000 Mbit/sec data rate is selected.

## Connector

### 44-Pin IDE Connector: JCD1

This 44-pin IDE connector connects to an optional converter that enables connection to one 44-pin IDE device and one 40-pin IDE device, such as hard disk drives, CD-ROM and other IDE devices.

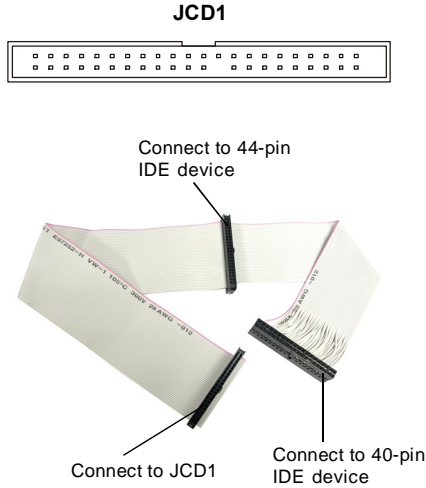

### Important

*If you install two IDE devices on the same cable, you must configure the drives separately to master / slave mode by setting jumpers. Refer to IDE device's documentation supplied by the vendors for jumper setting instructions.*

## Serial Attached SCSI Connector: MINISAS1, MINISAS2

The SAS connector is a new generation serial communication protocol for devices designed to allow for much higher speed data transfers. It supports data transfer speeds up to 3 Gbit/s. SAS uses serial communication instead of the parallel method found in traditional SCSI devices but still uses SCSI commands for interacting with SAS devices. Each SAS connector can connect to 1 disk drive.

## Serial ATA Connector: SATA0 ~ SATA5

This connector is a high-speed Serial ATA interface port. Each connector can connect to one Serial ATA device.

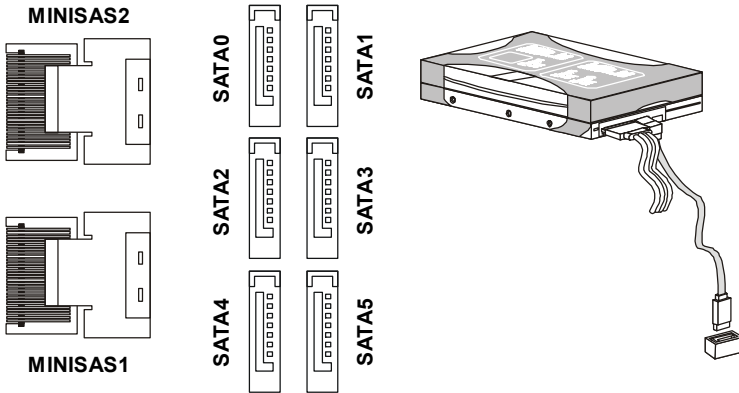

### Important

*Please do not fold the SATA/SAS accessory cable into 90-degree angle. Otherwise, data loss may occur during transmission.*

### Serial Port Connector: COM2

This connector is a 16550A high speed communications port that sends/receives 16 bytes FIFOs. You can attach a serial device to it through the optional serial port bracket.

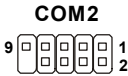

Pin Definition

PIN	SIGNAL	DESCRIPTION
1	DCD	Data Carry Detect
2	SIN	Serial In or Receive Data
3	SOUT	Serial Out or Transmit Data
4	DTR	Data Terminal Ready
5	GND	Ground
6	DSR	Data Set Ready
7	RTS	Request To Send
8	CTS	Clear To Send
9	RI	Ring Indicate

### Fan Power Connector: CPU0\_FAN, CPU1\_FAN, SYS\_FAN1/2/3/4/5

The fan power connectors support system cooling fan with +12V. When connecting the wire to the connectors, always note that the red wire is the positive and should be connected to the +12V; the black wire is Ground and should be connected to GND. If the mainboard has a System Hardware Monitor chipset onboard, you must use a specially designed fan with speed sensor to take advantage of the CPU fan control.

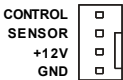

CPU0\_FAN

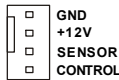

CPU1\_FAN,  
SYS\_FAN4

SYS\_FAN1/2/3/5



CONTROL  
SENSOR  
+12V  
GND



#### Important

*Please refer to the recommended CPU fans at processor's official website or consult the vendors for proper CPU cooling fan.*

## Chassis Intrusion Switch Connector: INTRUDER

This connector connects to the chassis intrusion switch cable. If the chassis is opened, the chassis intrusion mechanism will be activated. The system will record this status and show a warning message on the screen. To clear the warning, you must enter the BIOS utility and clear the record.

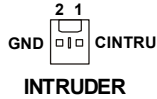

## Front USB Connector: JUSB2, JUSB3

This connector, compliant with Intel® I/O Connectivity Design Guide, is ideal for connecting high-speed USB interface peripherals such as **USB HDD, digital cameras, MP3 players, printers, modems and the like.**

Pin Definition

PIN	SIGNAL	PIN	SIGNAL
1	VCC	2	VCC
3	USB0-	4	USB1-
5	USB0+	6	USB1+
7	GND	8	GND
9	Key (no pin)	10	NC



USB 2.0 Bracket  
(Optional)

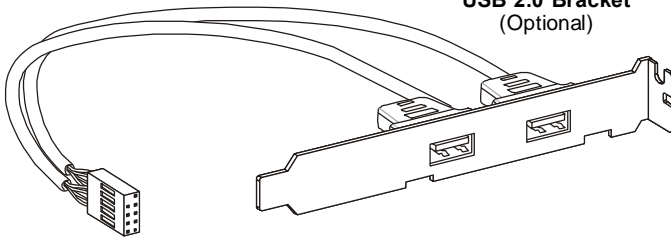

### Important

*Note that the pins of VCC and GND must be connected correctly to avoid possible damage.*

### ME Enable/Disable Header: JGPIO33

This connector is provided for factory use only.

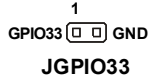

### I2C Bus Connector: JSMBUS1

This connector, known as I<sup>2</sup>C, is for users to connect System Management Bus (SMBus) interface.

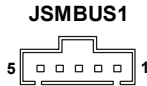

Pin Definition

PIN	SIGNAL
1	SMB Clock
2	SMB Data
3	PSAlert
4	GND
5	+3.3V

### SPI Flash ROM Connector: J2

This connector is used to flash SPI flash ROM.

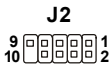

Pin Definition

Pin	Description	Pin	Description
1	+3.3V DUAL	2	+3.3V DUAL
3	SPI_MISO	4	SPI_MOSI
5	SPI_CS0#	6	SPI_CLK
7	GND	8	GND
9	SPI_HOLD#	10	NC

### TPM Connector: JTPM1 (Optional)

This connector connects to an optional TPM (Trusted Platform Module). Please refer to the TPM security platform manual for more details.

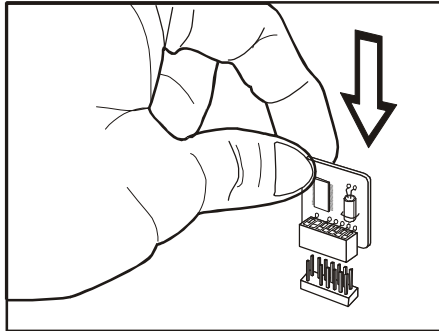
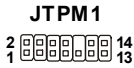

PIN	SIGNAL	DESCRIPTION	PIN	SIGNAL	DESCRIPTION
1	LCLK	LPC clock	2	+3.3V DUAL	3.3V standby power
3	LRST#	LPC reset	4	+3.3V	3.3V power
5	LAD0	LPC address & data pin0	6	SIRQ	Serial IRQ
7	LAD1	LPC address & data pin1	8	+5V	5V power
9	LAD2	LPC address & data pin2	10	KEY	No pin
11	LAD3	LPC address & data pin3	12	GND	Ground
13	LFRAME#	LPC Frame	14	GND	Ground

## Front Panel Connector: JSS11

The mainboard provides one front panel connector for electrical connection to the front panel switches and LEDs.

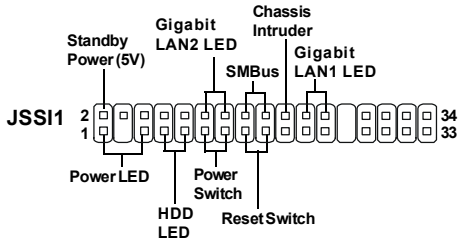

JSS11 Pin Definition

Pin	Description	Pin	Description
1	Power LED +	2	+5VSB
3	Key	4	NC
5	Power LED -	6	NC
7	HDD Activity LED +	8	System Status LED +
9	HDD Activity LED -	10	System Status LED -
11	PowerSwitch+	12	LAN2 Activity LED +
13	PowerSwitch-	14	LAN2 Activity LED -
15	ResetSwitch+	16	SMBus DAT
17	ResetSwitch-	18	SMBus CLK
19	Buzzer+	20	Chassis Intrusion
21	Buzzer-	22	LAN1 Activity LED +
23	NMI to CPU Switch	24	LAN1 Activity LED -
25	Key	26	Key
27	ID LED+	28	SGPIO Clock
29	ID LED-	30	SGPIO Load
31	ID#	32	SGPIO Dataout 0
33	GND	34	SGPIO Dataout 1

## Jumper

### BIOS Recovery Jumper: RECOVERY

Users can short connect pin#2-3 to recover the system BIOS with a Recovery Floppy. When the system is done with the job, the buzzer will beep to remind the user to set the jumper to its normal state (pin#1-2 short connected).



### BIOS Write Protect Jumper: JBIOS\_WP

This jumper is used to enable/disable the BIOS flash. When you intend to update the BIOS code, uncap this jumper first. Under normal operation, we suggest that you disable the BIOS flash by capping this jumper to protect the system BIOS from virus infection.



### Clear CMOS Jumper: CLR\_CMOS

There is a CMOS RAM onboard that has a power supply from an external battery to keep the data of system configuration. With the CMOS RAM, the system can automatically boot OS every time it is turned on. If you want to clear the system configuration, set the jumper to clear data.



### Important

*You can clear CMOS by shorting 2-3 pin while the system is off. Then return to 1-2 pin position. Avoid clearing the CMOS while the system is on; it will damage the mainboard.*

## Slot

### PCI (Peripheral Component Interconnect) Express Slot

The PCI Express slot supports the PCI Express interface expansion card.  
 The PCI Express 2.0 x16 slot supports up to 8.0 GB/s transfer rate.  
 The PCI Express 2.0 x8 slot supports up to 4.0 GB/s transfer rate.  
 The PCI Express 2.0 x4 slot supports up to 2.0 GB/s transfer rate.

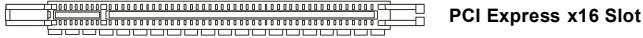

PCI Express x16 Slot

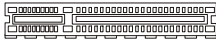

PCI Express x8 Slot

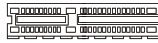

PCI Express x4 Slot

### PCI (Peripheral Component Interconnect) Slot

The PCI slot supports LAN card, SCSI card, USB card, and other add-on cards that comply with PCI specifications.

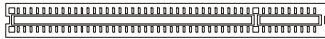

32-bit PCI Slot



### Important

*When adding or removing expansion cards, make sure that you unplug the power supply first. Meanwhile, read the documentation for the expansion card to configure any necessary hardware or software settings for the expansion card, such as jumpers, switches or BIOS configuration.*

## Chapter 3

# BIOS Setup

This chapter provides information on the BIOS Setup program and allows you to configure the system for optimum use.

You may need to run the Setup program when:

- ◆ An error message appears on the screen during the system booting up, and requests you to run SETUP.
- ◆ You want to change the default settings for customized features.

## Entering Setup

Power on the computer and the system will start POST (Power On Self Test) process. When the message below appears on the screen, press <Del> key to enter Setup.

### **Press Del to enter SETUP**

If the message disappears before you respond and you still wish to enter Setup, restart the system by turning it OFF and On or pressing the RESET button. You may also restart the system by simultaneously pressing <Ctrl>, <Alt>, and <Delete> keys.



### Important

- 1. The items under each BIOS category described in this chapter are under continuous update for better system performance. Therefore, the description may be slightly different from the latest BIOS and should be held for reference only.*
- 2. Upon boot-up, the 1st line appearing after the memory count is the BIOS version. It is usually in the format:*

*A96C8IMS V1.0 022709 where:*

*1st digit refers to BIOS maker as A = AMI, W = AWARD, and P = PHOENIX.*

*2nd - 5th digit refers to the model number.*

*6th digit refers to the chipset as I = Intel, N = nVidia, and V = VIA.*

*7th - 8th digit refers to the customer as MS = all standard customers.*

*V1.0 refers to the BIOS version.*

*022709 refers to the date this BIOS was released.*

## Control Keys

<↑>	Move to the previous item
<↓>	Move to the next item
<←>	Move to the item in the left hand
<→>	Move to the item in the right hand
<Enter>	Select the item
<Esc>	Jumps to the Exit menu or returns to the main menu from a submenu
<+/PU>	Increase the numeric value or make changes
<-/PD>	Decrease the numeric value or make changes
<F9>	Load Optimized Defaults
<F8>	Load Fail-Safe Defaults
<F10>	Save all the CMOS changes and exit

## Getting Help

After entering the Setup menu, the first menu you will see is the Main Menu.

### Main Menu

The main menu lists the setup functions you can make changes to. You can use the arrow keys (↑↓) to select the item. The on-line description of the highlighted setup function is displayed at the bottom of the screen.

### Sub-Menu

If you find a right pointer symbol (as shown in the right view) appears to the left of certain fields that means a sub-menu can be launched from this field. A sub-menu contains additional options for a field parameter. You can use arrow keys (↑↓) to highlight the field and press <Enter> to call up the sub-menu. Then you can use the control keys to enter values and move from field to field within a sub-menu. If you want to return to the main menu, just press the <Esc >.

▶ Primary IDE Master  
▶ Primary IDE Slave

### General Help <F1>

The BIOS setup program provides a General Help screen. You can call up this screen from any menu by simply pressing <F1>. The Help screen lists the appropriate keys to use and the possible selections for the highlighted item. Press <Esc> to exit the Help screen.

## The Menu Bar

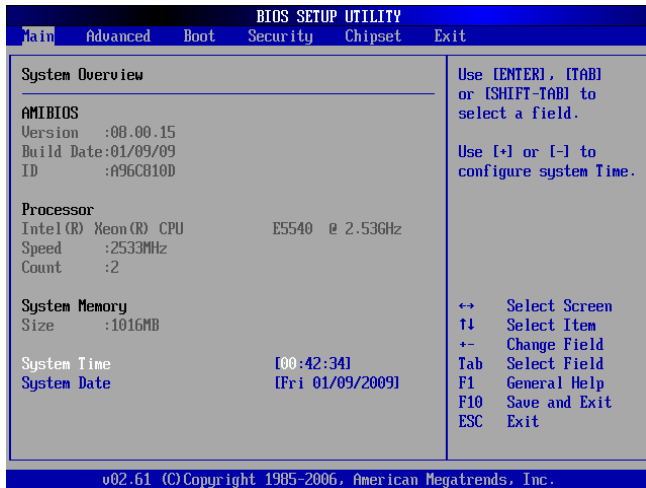

### ► Main

Use this menu for basic system configurations, such as time, date etc.

### ► Advanced

Use this menu to set up the items of special enhanced features.

### ► Boot

Use this menu to specify the priority of boot devices.

### ► Security

Use this menu to set supervisor and user passwords.

### ► Chipset

This menu controls the advanced features of the onboard Northbridge and Southbridge.

### ► Exit

This menu allows you to load the BIOS default values or factory default settings into the BIOS and exit the BIOS setup utility with or without changes.

## Main

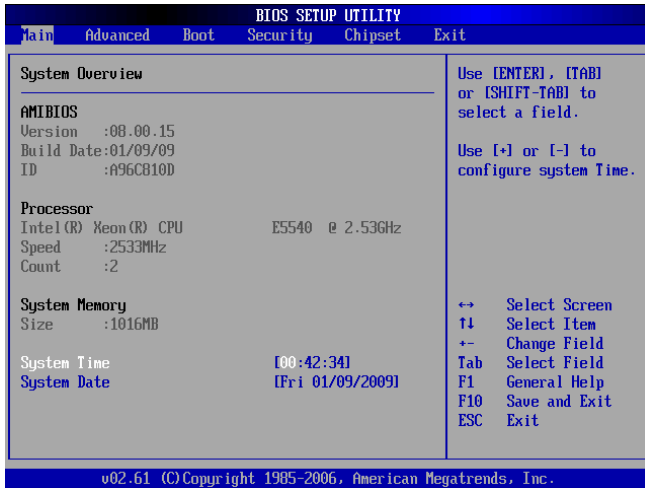

### ► AMI BIOS, Processor, System Memory

These items show the firmware and hardware specifications of your system. Read only.

### ► System Time

This setting allows you to set the system time. The time format is <Hour> <Minute> <Second>.

### ► System Date

This setting allows you to set the system date. The date format is <Day>, <Month> <Date> <Year>.

## Advanced

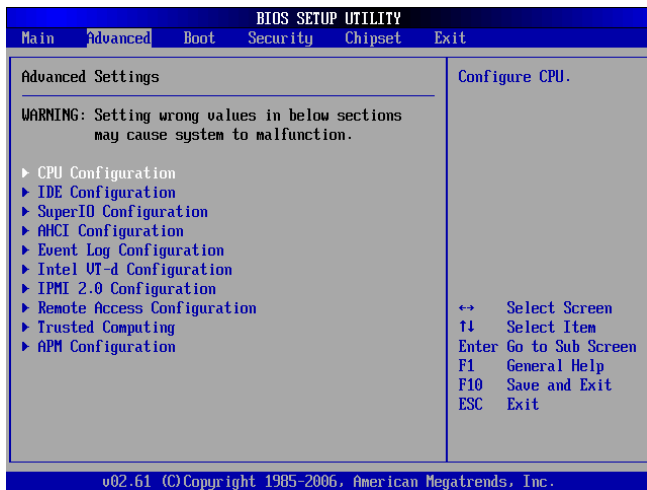

## ► CPU Configuration

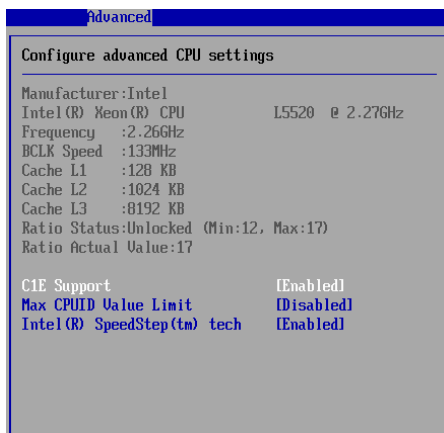

**► C1E Support**

When the C1E Support (Enhanced Halt Powerdown State) is enabled, the processor will transition to a lower core to bus ratio and lower voltage ID driven by the processor to the voltage regulator before entering Halt Powerdown State (C1). Not all processors support Enhanced Halt Powerdown State (C1E).

**► Max CPUID Value Limit**

The Max CPUID Value Limit BIOS feature allows you to circumvent problems with older operating systems that do not support the Intel Pentium 4 processor with Hyper-Threading Technology. When enabled, the processor will limit the maximum CPUID input value to 03h when queried, even if the processor supports a higher CPUID input value. When disabled, the processor will return the actual maximum CPUID input value of the processor when queried.

**► Intel(R) SpeedStep(tm) Tech**

EIST (Enhanced Intel SpeedStep Technology) allows the system to dynamically adjust processor voltage and core frequency, which can result in decreased average power consumption and decreased average heat production.

► IDE Configuration

With “*Configure SATA as*” set to [IDE]

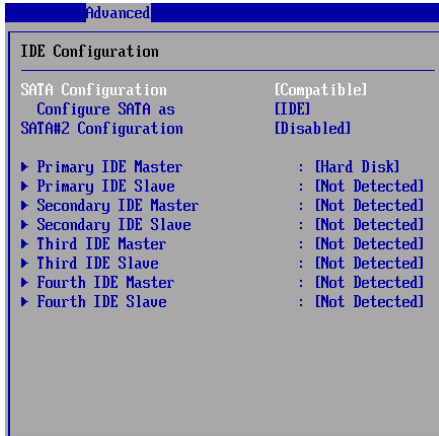

With “*Configure SATA as*” set to [AHCI]

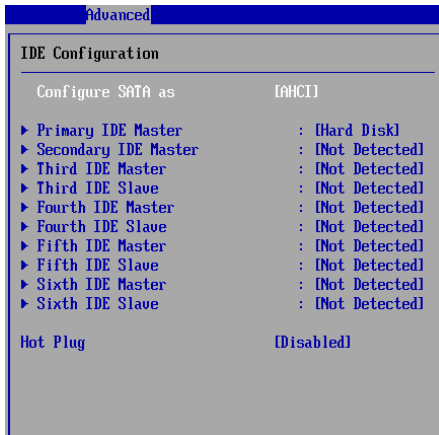

► **SATA Configuration, SATA#2 Configuration**

This setting specifies SATA controller mode. Please note that Pre-Win2K OS do not work in Enhanced mode.

[Compatible] SATA and PATA drives are auto-detected and placed in Legacy mode.

[Enhanced] SATA and PATA drives are auto-detected and placed in Native IDE mode.

► **Configure SATA as**

This setting specifies the operation mode of the onboard SATA drive. Setting options: [IDE], [AHCI], [RAID].

► **Primary/Secondary/Third/Fourth/Fifth/Sixth IDE Master/Slave**

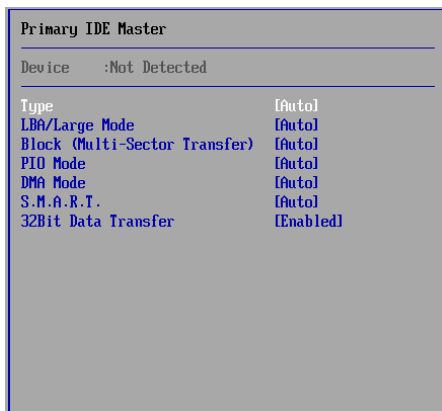

- [Type] Press PgUp/<+> or PgDn/<-> to select [Manual], [None] or [Auto] type. Note that the specifications of your drive must match with the drive table. The hard disk will not work properly if you enter improper information for this category. If your hard disk drive type is not matched or listed, you can use [Manual] to define your own drive type manually.
- [LBA/Large Mode] Enabling LBA causes Logical Block Addressing to be used in place of Cylinders, Heads and Sectors
- [Block(Multi-Sector Transfer)] Any selection except Disabled determines the number of sectors transferred per block
- [PIO Mode] Indicates the type of PIO (Programmed Input/Output)
- [DMA Mode] Indicates the type of Ultra DMA
- [S.M.A.R.T.] This allows you to activate the S.M.A.R.T. (Self-Monitoring Analysis & Reporting Technology) capability for the hard disks. S.M.A.R.T is a utility that monitors your disk status to predict hard disk failure. This gives you an opportunity to move data from a hard disk that is going to fail to a safe place before the hard disk becomes offline.
- [32 Bit Data Transfer] Enables 32-bit communication between CPU and IDE device

### ► Hot Plug

This setting enables/disables the hot plug function of the onboard SATA devices and only appears when **Configure SATA as** is set to [AHCI] or [RAID].

### ► Super IO Configuration

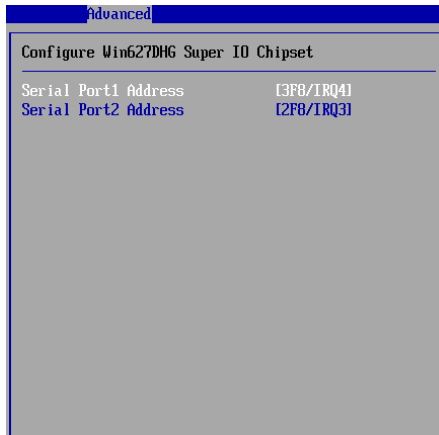

### ► Serial Port 1 Address, Serial Port 2 Address

Select an address and a corresponding interrupt for the serial port 1/2.

## ► AHCI Configuration

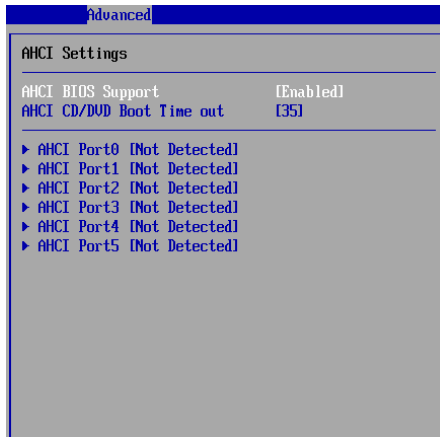

### ► AHCI BIOS Support

This BIOS feature controls the SATA controller's AHCI (Advanced Host Controller Interface) functionality. It is a new interface specification that enables advanced SATA features like Native Command Queuing (NCQ) and hot-plugging.

### ► AHCI CD/DVD Boot Time Out

This setting specifies the delay of the AHCI CD/DVD drivers loading for multi-read/write. Changing the value to 0 will grant no delay at boot.

### ► AHCI Port 0/1/2/3/4/5

#### ► SATA Port 0

This setting controls the SATA port 0.

#### ► S.M.A.R.T.

This allows you to activate the S.M.A.R.T. (Self-Monitoring Analysis & Reporting Technology) capability for the hard disks. S.M.A.R.T is a utility that monitors your disk status to predict hard disk failure. This gives you an opportunity to move data from a hard disk that is going to fail to a safe place before the hard disk becomes offline.

► **Event Log Configuration**

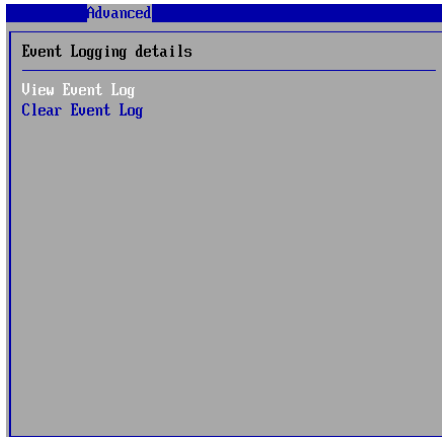

► **View Event Log**

Press [Enter] to view the contents of the DMI event log.

► **Clear Event Log**

When this setting is set to [OK], the DMI event log will be cleared instantly.

► Intel VT-d Configuration

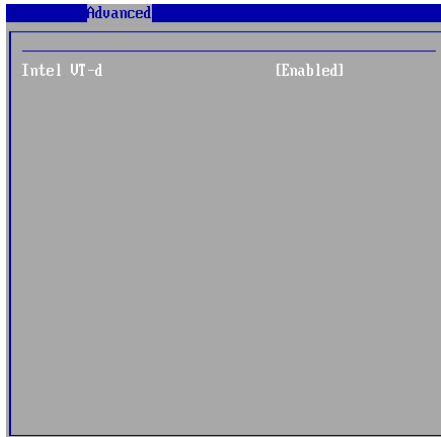

► Intel VT-d

Intel Virtualization Technology for Directed I/O (Intel VT-d) provides the capability to ensure improved isolation of I/O resources for greater reliability, security, and availability.

## ► IPMI 2.0 Configuration

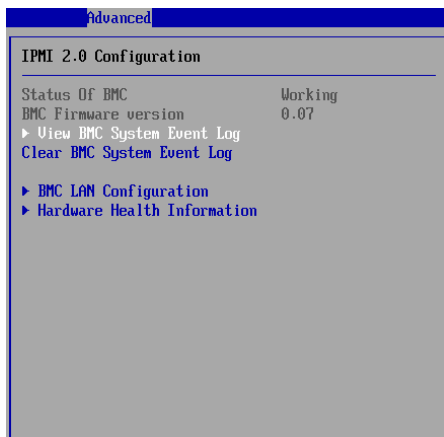

### ► Status of BMC, BMC Firmware Version

These settings show the status of the BMC (Baseboard Management Controller) chip and its firmware version. Read only.

### ► View BMC System Event Log

Use this function to view system event logs recorded by BMC.

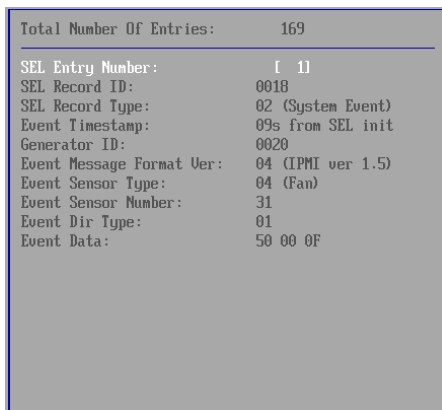

### ► Clear BMC System Event Log

Use this function to clear system event logs recorded by BMC.

► **BMC LAN Configuration**

LAN Configuration	
BMC IP Source:	Static IP
Current MAC address in BMC:	00.19.DB.01.02.03
Notify BMC IP Source	[No change]
Current IP address in BMC:	172.016.097.030
Current Subnet Mask in BMC:	255.255.255.000
Current Gateway in BMC:	172.016.097.002

► **Notify BMC IP Source**

Use this setting to check the BMC IP source.

► **Current IP Address in BMC, Current Subnet Mask in BMC, Current Gateway in BMC**

Use these settings to view the IP address, subnet mask, and gateway in BMC.

► **Hardware Health Information**

These items display the current status of all of the monitored hardware devices/components such as voltages, temperatures and all fans' speeds.

Hardware Health Information
► Temperature Information
► Fan Speed Information
► Voltage Information

► Temperature Information

Temperature Information	
CPU 0 Temperature	:N/A
CPU 1 Temperature	:N/A
SYS 1 Temperature	:37°C/98°F
SYS 2 Temperature	:38°C/100°F
SYS 3 Temperature	:39°C/102°F

► Fan Speed Information

Fan Speed Information	
Notify BMC FAN Type	[3 PIN]
CPU0_FAN	:5500 RPM
CPU1_FAN	:3500 RPM
SYS_FAN1	:N/A
SYS_FAN2	:N/A
SYS_FAN3	:N/A
SYS_FAN4	:N/A
SYS_FAN5	:N/A

► Notify BMC FAN Type

This setting specifies the BMC fan type.

► Voltage Information

Voltage Information	
UCORE_CPU0	: 1.339 V
+1.1V_CPU0	: 1.097 V
+1.1V_IDH	: 1.072 V
DDR3_CPU0	: 1.494 V
UBAT	: 3.276 V
+5V	: 5.096 V
+12	:11.904 V
UCORE_CPU1	: 1.339 V
+1.1V_CPU1	: 1.097 V
+1.5V_ICH	: 1.482 V
DDR3_CPU1	: 1.494 V
+3.3V	: 3.336 V

► Remote Access Configuration

Advanced	
Configure Remote Access type and parameters	
Remote Access	[Enabled]
Serial port number	[COM1]
Base Address, IRQ	[3F8h, 4]
Serial Port Mode	[115200 B,n,1]
Flow Control	[None]
Redirection After BIOS POST	[Always]
Terminal Type	[ANSI]

► Remote Access

The setting enables/disables the remote access function. When set to [Enabled], users may configure the following settings for remote access type and parameters.

► Serial Port Number, Base Address, IRQ, Serial Port Mode

Use these settings to configure ports for remote access.

► **Flow Control**

Flow control is the process of managing the rate of data transmission between two nodes. It's the process of adjusting the flow of data from one device to another to ensure that the receiving device can handle all of the incoming data. This is particularly important where the sending device is capable of sending data much faster than the receiving device can receive it.

► **Redirection After BIOS POST**

This setting determines whether or not to keep terminals' console redirection running after the BIOS POST has booted.

► **Terminal Type**

To operate the system's console redirection, you need a terminal supporting ANSI terminal protocol and a RS-232 null modem cable connected between the host system and terminal(s). This setting specifies the type of terminal device for console redirection.

► **Trusted Computing**

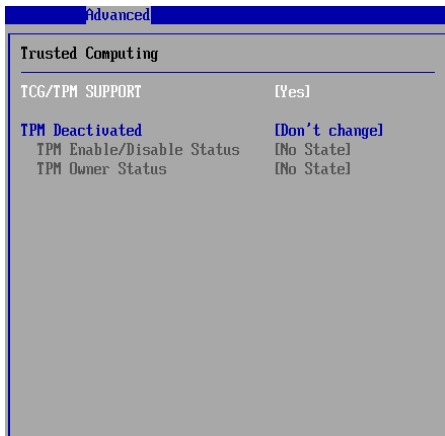

► **TCG/TPM Support**

This setting controls the Trusted Platform Module (TPM) designed by the Trusted Computing Group (TCG). TPMs are special-purpose integrated circuits (ICs) built into a variety of platforms to enable strong user authentication and machine attestation—essential to prevent inappropriate access to confidential and sensitive information and to protect against *compromised networks*. TPM Services is now a new feature set in Windows Server "Longhorn" and Windows Vista.

▶ **TPM Deactivated**

When the TPM is cleared, all the keys you previously had stored on your vault will be lost. You should create an archive of your TPM Keys before clearing the TPM. To recover your TPM keys, you will need to restore your keys from an archive.

▶ **TPM Enable/Disable Status**

This setting displays the TPM enable/disable status. Read only.

▶ **TPM Owner Status**

This setting shows the TPM ownership. Read only.

▶ **APM Configuration**

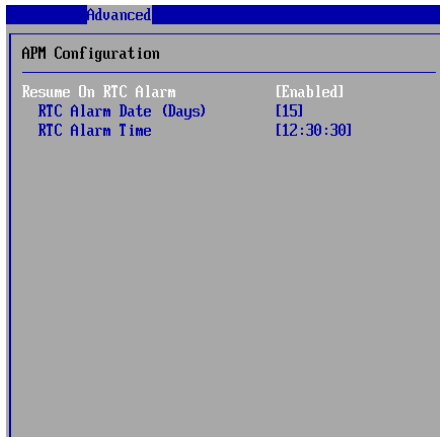

▶ **Resume On RTC Alarm**

When [Enabled], you can set the date and time at which the RTC (real-time clock) alarm awakens the system from suspend mode.

▶ **RTC Alarm Date (Days), RTC Alarm Time**

If **Resume On RTC Alarm** is set to [Enabled], the system will automatically resume (boot up) on a specific date/hour/minute/second specified in these fields (using the <+> and <-> to select the date & time settings). Available settings for each item are:

Date	01 ~ 31, Every Day
Time (HH:MM:SS)	00 ~ 23 : 00 ~ 59 : 00 ~ 59

## Boot

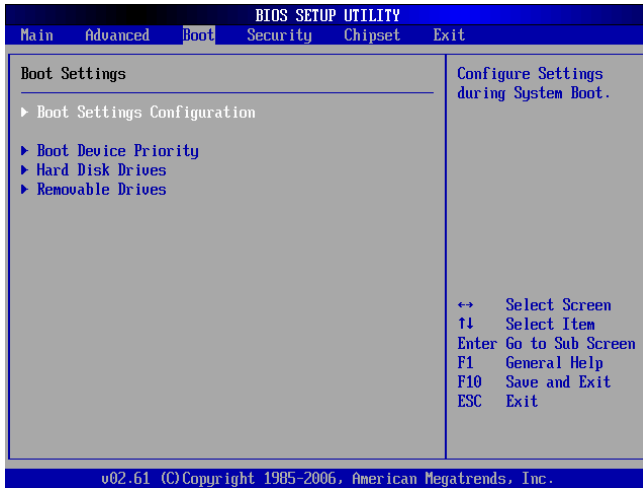

### ► Boot Settings Configuration

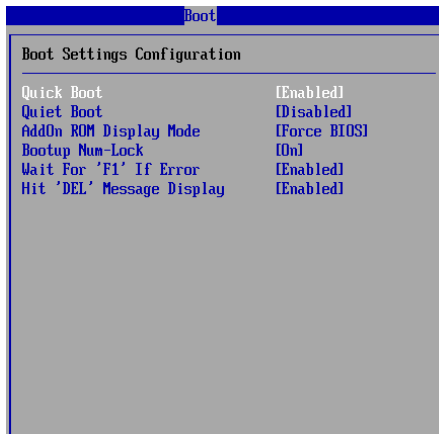

**► Quick Boot**

Enabling this setting will cause the BIOS power-on self test routine to skip some of its tests during bootup for faster system boot.

**► Quiet Boot**

This BIOS feature determines if the BIOS should hide the normal POST messages with the motherboard or system manufacturer's full-screen logo.

When it is enabled, the BIOS will display the full-screen logo during the boot-up sequence, hiding normal POST messages.

When it is disabled, the BIOS will display the normal POST messages, instead of the full-screen logo.

Please note that enabling this BIOS feature often adds 2-3 seconds of delay to the booting sequence. This delay ensures that the logo is displayed for a sufficient amount of time. Therefore, it is recommended that you disable this BIOS feature for a faster boot-up time.

**► AddOn ROM Display Mode**

This item is used to determine the display mode when an optional ROM is initialized during POST. When set to [Force BIOS], the display mode used by AMI BIOS is used. Select [Keep Current] if you want to use the display mode of optional ROM.

**► Bootup Num-Lock**

This setting is to set the Num Lock status when the system is powered on. Setting to [On] will turn on the Num Lock key when the system is powered on. Setting to [Off] will allow users to use the arrow keys on the numeric keypad.

**► Wait For 'F1' If Error**

When this setting is set to [Enabled] and the boot sequence encounters an error, it asks you to press F1. If disabled, the system continues to boot without waiting for you to press any keys.

**► Hit 'DEL' Message Display**

Set this option to [Disabled] to prevent the message as follows:

***Hit Del if you want to run setup***

It will prevent the message from appearing on the first BIOS screen when the computer boots. Set it to [Enabled] when you want to run the BIOS Setup Utility.

► **Boot Device Priority**

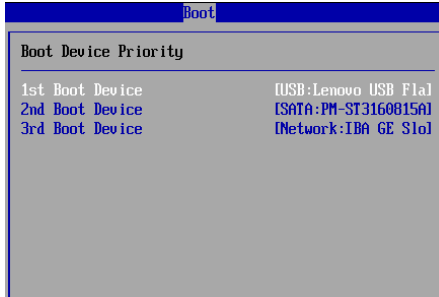

► **1st Boot Device, 2nd Boot Device, 3rd Boot Device**

The items allow you to set the sequence of boot devices where BIOS attempts to load the disk operating system. First press <Enter> to enter the sub-menu. Then you may use the arrow keys (↑↓) to select the desired device, then press <+>, <-> or <PageUp>, <PageDown> key to move it up/down in the priority list.

► **Hard Disk Drives**

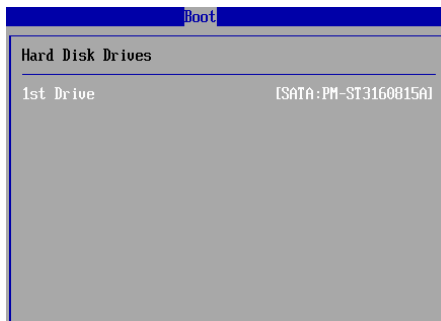

► **1st Drive**

The items allow you to set the sequence of HDD devices where BIOS attempts to load the disk operating system. First press <Enter> to enter the sub-menu. Then you may use the arrow keys (↑↓) to select the desired device, then press <+>, <-> or <PageUp>, <PageDown> key to move it up/down in the priority list.

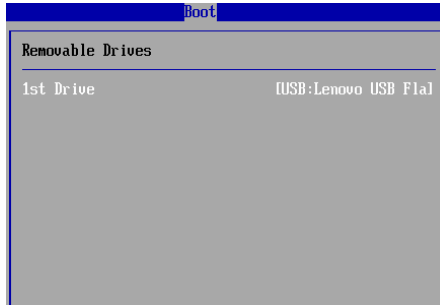
**► Removable Drives****► 1st Drive**

This setting allows users to set the priority of the removable devices. First press <Enter> to enter the sub-menu. Then you may use the arrow keys (↑↓) to select the desired device, then press <+>, <-> or <PageUp>, <PageDown> key to move it up/down in the priority list.

## Security



### ► Supervisor Password / Change Supervisor Password

Supervisor Password controls access to the BIOS Setup utility. These settings allow you to set or change the supervisor password.

### ► User Password / Change User Password

User Password controls access to the system at boot. These settings allow you to set or change the user password.

### ► Chassis Intrusion

The field enables or disables the feature of recording the chassis intrusion status and issuing a warning message if the chassis is once opened. To clear the warning message, set the field to [Reset]. The setting of the field will automatically return to the default value later.

# Chipset

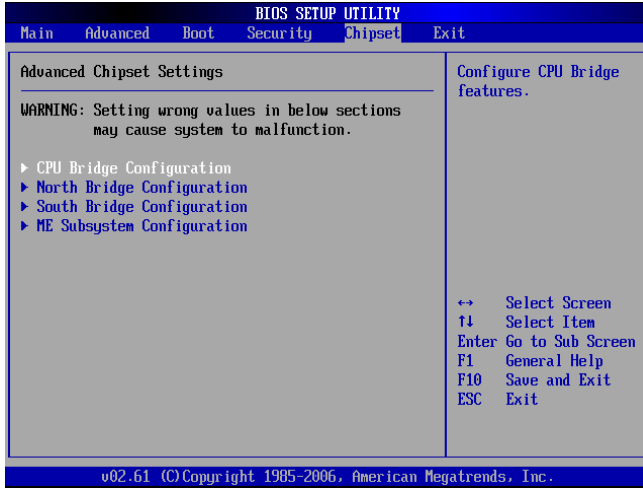

## ▶ CPU Bridge Configuration

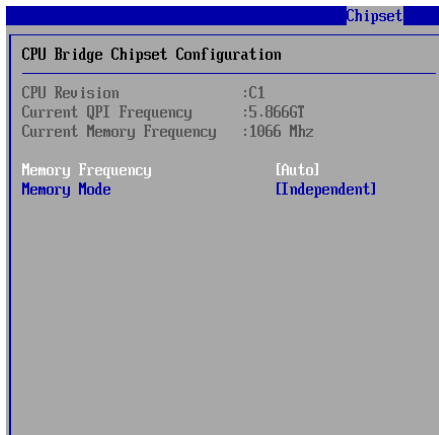

### ▶ Memory Frequency

This item allows you to select the memory frequency.

### ▶ Memory Mode

This setting specifies the memory mode.

### ▶ North Bridge Configuration

This sub-menu shows the north bridge information.



### ▶ MINI SAS

This setting enables/disables the onboard mini SAS controller.

### ▶ SAS OPROM

This setting enables/disables the initialization of the SAS boot ROM during bootup. Selecting [Disabled] will speed up the boot process.

► South Bridge Configuration

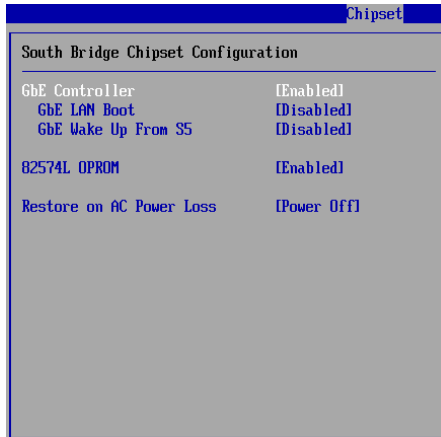

► GbE Controller

These settings disable/enable the specified LAN controllers.

► GbE LAN Boot, 82574L OPROM

The items enable or disable the initialization of the onboard LAN Boot ROMs during bootup. Selecting [Disabled] will speed up the boot process.

► GbE Wake Up From S5

This field specifies whether the system will be awakened from power saving modes when activity or input signal of the onboard Gigabit LAN is detected.

► Restore on AC Power Loss

This setting specifies whether your system will reboot after a power failure or interrupt occurs. Available settings are:

- [Power Off] Leaves the computer in the power off state.
- [Power On] Leaves the computer in the power on state.
- [Last State] Restores the system to the previous status before power failure or interrupt occurred.

► ME Subsystem Configuration

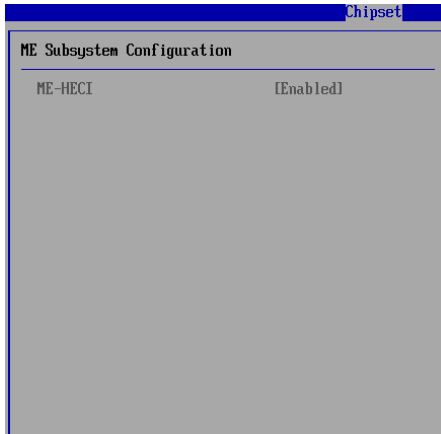

► ME-HECI

This setting enables/disables ME-HECI. Host Embedded Controller Interface (HECI) driver is a software interface that is used to communicate to the AMT subsystem (Management Engine) to access AMT capabilities. Communication between the local host operating system (OS) and the ME is accomplished by means of the HECI driver. HECI is bi-directional, as either the host OS or Intel AMT firmware can initiate transactions.

## Exit

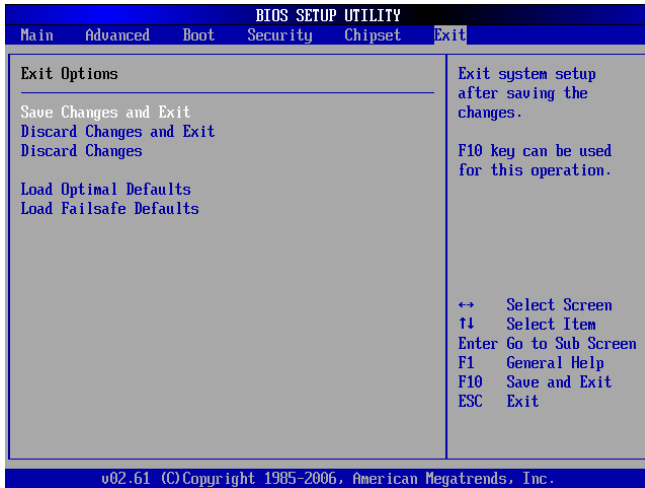

### ► Save Changes and Exit

Save changes to CMOS and exit the Setup Utility.

### ► Discard Changes and Exit

Abandon all changes and exit the Setup Utility.

### ► Discard Changes

Abandon all changes and continue with the Setup Utility.

### ► Load Optimal Defaults

Use this menu to load the default values set by the mainboard manufacturer specifically for optimal performance of the mainboard.

### ► Load Failsafe Defaults

Use this menu to load the default values set by the BIOS vendor for stable system performance.

*This page is intentionally left blank.*

# *Appendix A*

## *Intel ICH10R SATA RAID*

This appendix will assist users in configuring and enabling RAID functionality on platforms



## Introduction

The ICH10R provides a hybrid solution that combines 6 independent SATAII ports for support of up to 6 Serial ATAII (Serial ATAII RAID) drives.

Serial ATAII (SATAII) is the latest generation of the ATA interface. SATA hard drives deliver blistering transfer speeds up to 3 Gb/s. Serial ATA uses long, thin cables, making it easier to connect your drive and improving the airflow inside your PC. The most outstanding features are:

1. Supports 3 Gb/s transfers with CRC error checking.
2. Supports Hot-plug-n-play feature.
3. Data handling optimizations including tagged command queuing, elevator seek and packet chain command.

Intel® ICH10R offers RAID level 0 (Striping), RAID level 1 (Mirroring and Duplexing), RAID level 5 (Block Interleaved Distributed Parity), RAID level 10 (A Stripe of Mirrors), Intel® Matrix Storage Technology and Intel® Rapid Recover Technology.

RAID 0 breaks the data into blocks which are written to separate hard drives. Spreading the hard drive I/O load across independent channels greatly improves I/O performance.

RAID 1 provides data redundancy by mirroring data between the hard drives and provides enhanced read performance.

RAID 5 Provides data striping at the byte level and also stripe error correction information. This results in excellent performance and good fault tolerance. Level 5 is one of the most popular implementations of RAID.

RAID 10 Not one of the original RAID levels, multiple RAID 1 mirrors are created, and a RAID 0 stripe is created over these.

Intel Matrix RAID Technology is the advanced ability for two RAID volumes to share the combined space of two hard drives being used in unison.

Intel Rapid Recover Technology utilizes RAID 1 functionality to copy data from a designated Master drive to a designated Recovery drive. The size of the Master drive must be less than or equal to the size of the Recovery drive. When a Recovery volume is created, complete capacity of the Master drive will be used as the Master volume. Only one Recovery Volume can exist on a system. There are 2 methods of updating the data on the Master to the Recovery drive. They are Continuous Update Policy and On Request Update Policy.



### Important

*The least number of hard drives for RAID 0, RAID 1, Recovery or Matrix mode is 2. The least number of hard drives for RAID 10 mode is 4. And the least number of hard drives for RAID 5 mode is 3.*

*All the information/ volumes/ pictures listed in your system might differ from the illustrations in this appendix.*

## BIOS Configuration

The Intel Matrix Storage Manager Option ROM should be integrated with the system BIOS on all motherboards with a supported Intel chipset. The Intel Matrix Storage Manager Option ROM is the Intel RAID implementation and provides BIOS and DOS disk services. Please use <Ctrl> + <I> keys to enter the "Intel(R) RAID for Serial ATA" status screen, which should appear early in system boot-up, during the POST (Power-On Self Test). Also, you need to enable the RAID function in BIOS to create, delete and reset RAID volumes.

### Using the Intel Matrix Storage Manager Option ROM

#### 1. Creating, Deleting and Resetting RAID Volumes:

The Serial ATA RAID volume may be configured using the RAID Configuration utility stored within the Intel RAID Option ROM. During the Power-On Self Test (POST), the following message will appear for a few seconds:



#### Important

*The "Device Model", "Serial #" and "Size" in the following example might be different from your system.*

```
Intel(R) Matrix Storage Manager option ROM v8.5.0.1030 ICH10R wRAID5
Copyright(C) 2003-08 Intel Corporation, All Rights Reserved.

RAID Volumes
None defined.

Physical Disks::
Port Device Model Serial # Size Type/Status(Vol ID)
0 HDS722580VLSA80 VNRB3EC20549SL 76.7GB Non-RAID Disk
1 HDS722580VLSA80 VNRB3EC20559SL 76.7GB Non-RAID Disk
2 HDS722580VLSA80 VNRB3EC20569SL 76.7GB Non-RAID Disk
3 HDS722580VLSA80 VNRB3EC20579SL 76.7GB Non-RAID Disk

Press <CTRL> <I> to enter Configuration Utility..
```

After the above message shows, press <Ctrl> and <I> keys simultaneously to enter the RAID Configuration Utility.



#### Important

*The following procedure is only available with a newly-built system or if you are reinstalling your OS. It should not be used to migrate an existing system to RAID.*

After pressing the <Ctrl> and <I> keys simultaneously, the following window will appear:

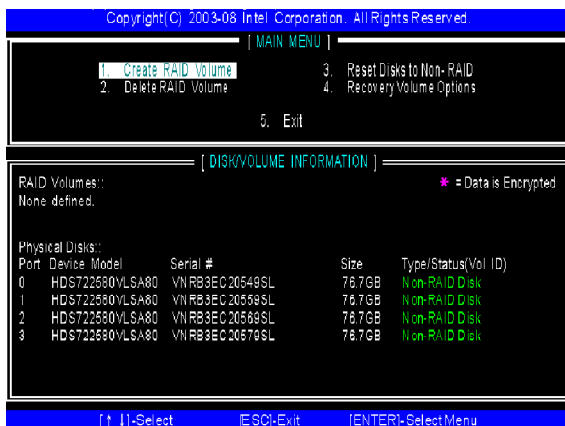

### (1) Create RAID Volume

1. Select option 1 "Create RAID Volume" and press <Enter> key. The following screen appears. Then in the **Name** field, specify a RAID Volume name and then press the <TAB> or <Enter> key to go to the next field.
2. Use the arrow keys to select the RAID level best suited to your usage model in **RAID Level**.

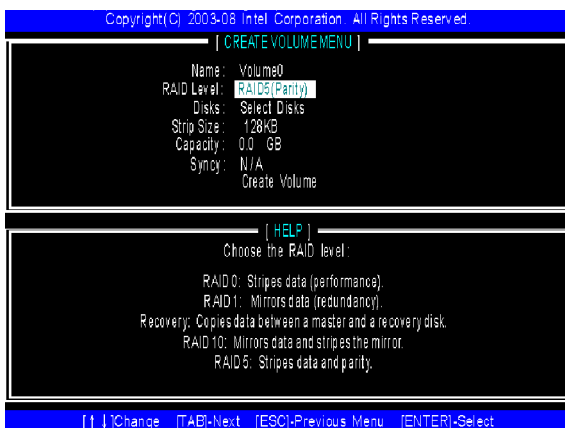

- In the **Disk** field, press <Enter> key and the following screen appears. Use <Space> key to select the disks you want to create for the RAID volume, then click <Enter> key to finish selection.

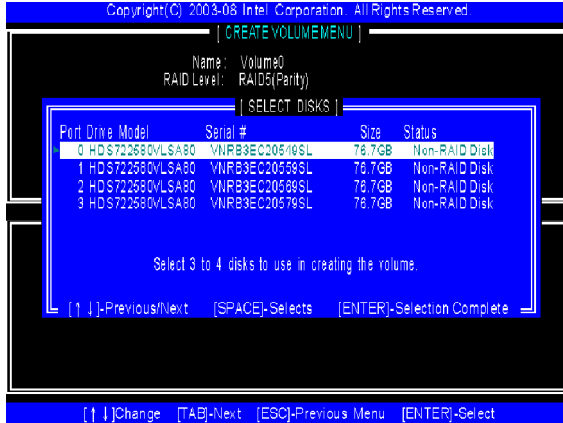

- Then select the strip value for the RAID array by using the “upper arrow” or “down arrow” keys to scroll through the available values, and pressing the <Enter> key to select and advance to the next field. The available values range from 4KB to 128 KB in power of 2 increments. The strip value should be chosen based on the planned parity usage. Here are some typical values:  
RAID0 – 128KB  
RAID10 – 64KB  
RAID5 – 64KB
- Then select the capacity of the volume in the **Capacity** field. The default value is the maximum volume capacity of the selected disks.

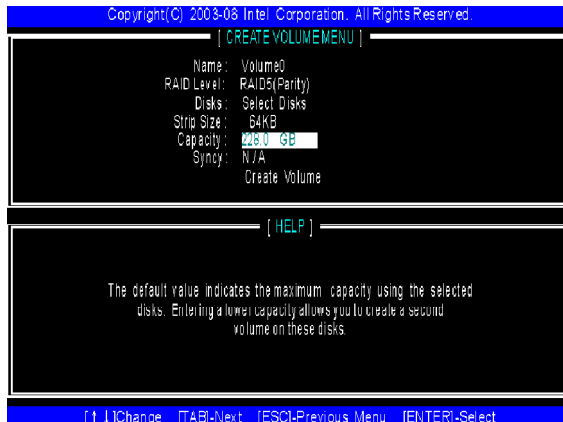



## Important

Since you want to create two volumes (Intel Matrix RAID Technology), this default size (maximum) needs to be reduced. Type in a new size for the first volume. As an example: if you want the first volume to span the first half of the two disks, re-type the size to be half of what is shown by default. The second volume, when created, will automatically span the remainder of two hard drives.

6. Then the following screen appears for you to confirm if you are sure to create the RAID volume. Press <Y> to continue.



7. Then the following screen appears to indicate that the creation is finished.

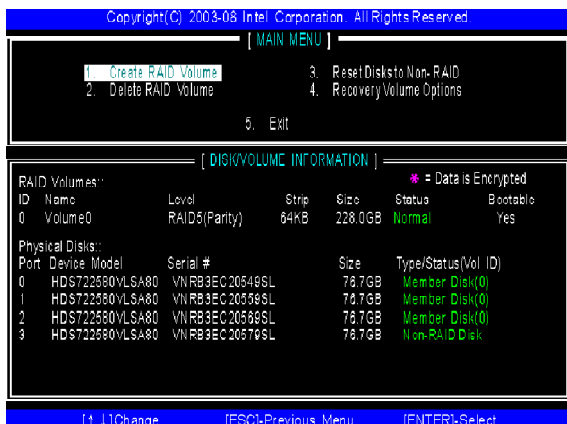

## (2) Delete RAID Volume

Here you can delete the RAID volume, but please be noted that all data on RAID drives will be lost.



### Important

*If your system currently boots to RAID and you delete the RAID volume in the Intel RAID Option ROM, your system will become unbootable.*

Select option 2 **Delete RAID Volume** from the main menu window and press <Enter> key to select a RAID volume for deletion. Then press <Delete> key to delete the selected RAID volume. The following screen appears.

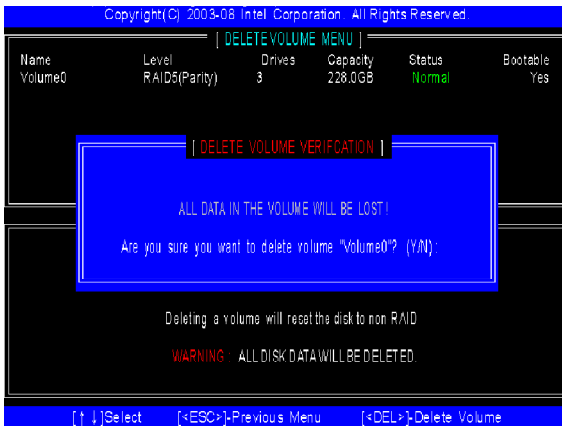

Press <Y> key to accept the volume deletion.

### (3) Reset Disks to Non-RAID

Select option 3 **Reset Disks to Non-RAID** and press <Enter> to delete the RAID volume and remove any RAID structures from the drives. The following screen appears:



Press <Y> key to accept the selection.



### Important

1. You will lose all data on the RAID drives and any internal RAID structures when you perform this operation.
2. Possible reasons to 'Reset Disks to Non-RAID' could include issues such as incompatible RAID configurations or a failed volume or failed disk.

#### (4) Recovery Volume Options

Select option 4 **Recovery Volume Options** and press <Enter> to change recovery volume mode. The following screen appears:

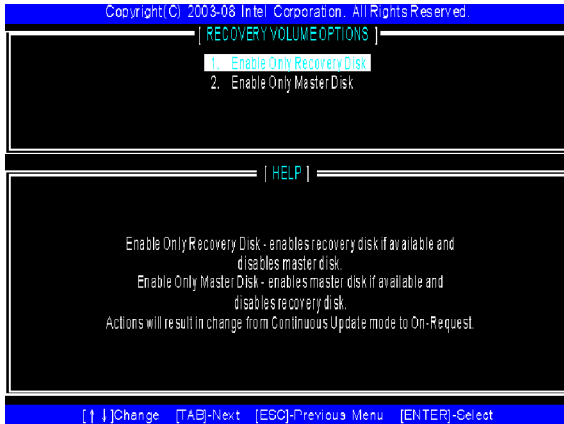

Recovery mode will change from Continuous Update to On-Request after you enable "Only Recovery Disk" or "Only Master Disk".

## Installing Driver

### Install Driver in Windows Server 2008/2003

#### ► New Windows Server 2008/2003 Installation

The following details the installation of the drivers while installing operating system.

1. When you start installing Windows Server 2008/2003, you may encounter a message stating, "Setup could not determine the type of one or more mass storage devices installed in your system". If this is the case, then you are already in the right place and are ready to supply the driver. For Windows 2003, if this is not the case, then press F6 when prompted at the beginning of Windows setup.
2. Press the "S" key to select "Specify Additional Device".
3. You should be prompted to insert a floppy disk containing the Intel® RAID driver into the A: drive.



#### Important

*Please follow the instruction below to make an "Intel® RAID Driver" for yourself.*

1. Insert the MSI CD into the CD-ROM drive.
  2. Click the "Browse CD" on the Setup screen.
  3. Copy all the contents in `\\SATA2_RAID\\f6flopy3288` (32 bits) or `\\SATA2_RAID\\f6flopy6488` (64 bits) to a formatted floppy diskette.
  4. The driver diskette for Intel® ICH10R RAID Controller is done.
4. During the Operating system installation, after selecting the location to install, click on "Load Driver" button to install a third party SCSI or RAID driver.
  5. When prompted, insert the floppy disk or media (CD/DVD or USB) you created in step 3 and press Enter.
  6. You should be shown a list of available SCSI Adapters.
  7. Select the appropriate Intel RAID controller and press ENTER.
  8. The next screen should confirm that you have selected the Intel® RAID controller. Press ENTER again to continue.
  9. You have successfully installed the Intel SATA RAID driver, and Windows setup should continue.
  10. Leave the disk in the floppy drive until the system reboots itself. Windows setup will need to copy the files from the floppy again after the RAID volume is formatted, and Windows setup starts copying files.\

► **Existing Windows Server 2008/2003 Driver Installation**

1. Insert the MSI CD into the CD-ROM drive.
2. The CD will auto-run and the setup screen will appear.
3. Under the **Server Drivers** tab, click on **SATA2 RAID Install**.
4. The drivers will be automatically installed.



► **Confirming Windows Server 2008/2003 Driver Installation**

1. Under Windows Server 2008/2003, open the **Control Panel** from **My Computer** followed by the System icon.
2. Choose the **Hardware** tab, then click the **Device Manager** tab.
3. Click the "+" in front of the **SCSI and RAID Controllers** hardware type. The driver **Intel(R) ICH10R SATA RAID Controller** should appear.

## Installing Software

### Install Intel Matrix Storage Console

The Intel Application Accelerator RAID Edition driver may be used to operate the hard drive from which the system is booting or a hard drive that contains important data. For this reason, you cannot remove or un-install this driver from the system after installation; however, you will have the ability to un-install all other non-driver components.

Insert the MSI CD and click on **Intel Matrix Storage Manager** under the **Utility** tab to install the software.



Click on this item

The **InstallShield Wizard** will begin automatically for installation showed as following:

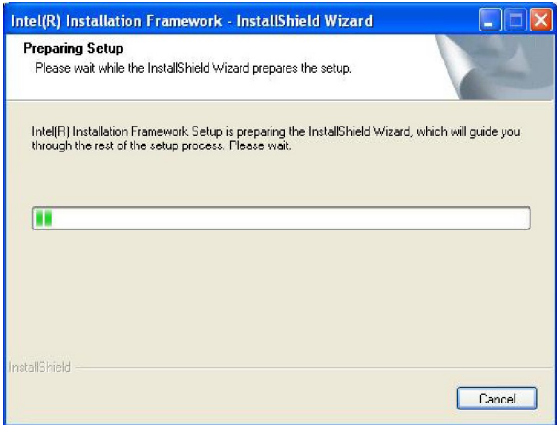

Click on the **Next** button to proceed the installation in the welcoming window.

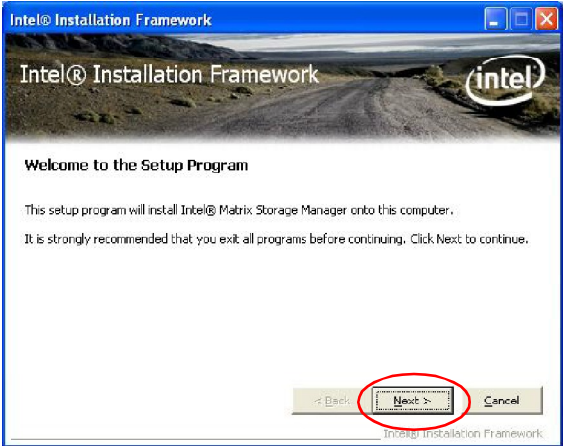

The window shows the components to be installed. Click **Next** button to continue.



After reading the license agreement in the following window, click **Yes** button to continue.

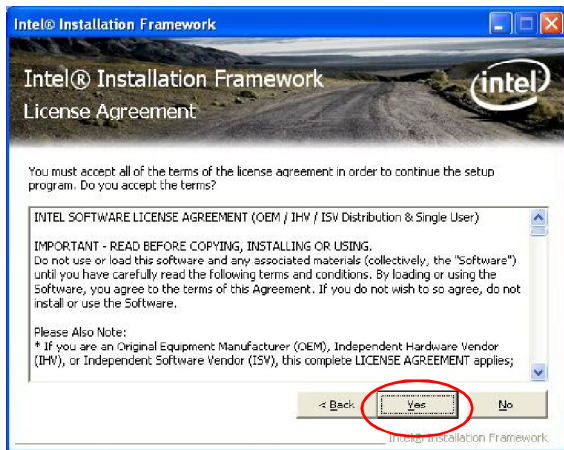

The following window appears to show the Readme File Information. It shows the system requirements and installation information.

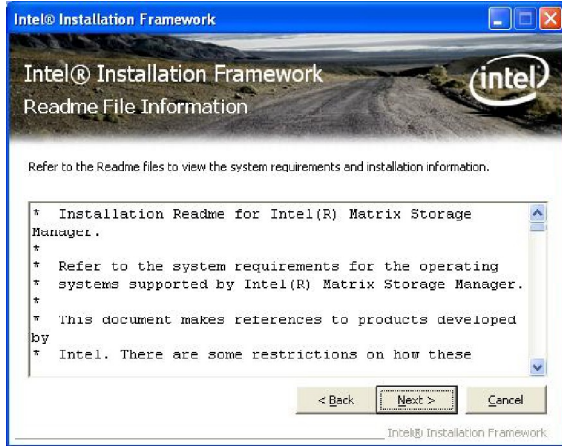

Once the installation is complete, the following window appears.

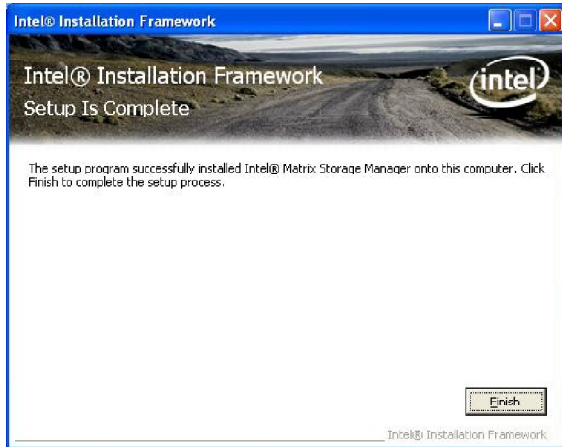

## RAID Migration Instructions

The Intel Matrix Storage Console offers the flexibility to upgrade from a single Serial ATA (SATA) hard drive to RAID configuration when an additional SATA hard drive is added to the system. This process will create a new RAID volume from an existing disk. However, several important steps must be followed at the time the system is first configured in order to take advantage of RAID when upgrading to a second SATA hard drive:

1. BIOS must be configured for RAID before installing Windows on the single SATA hard drive. Refer to **BIOS section** properly setting.
2. Install the Intel Application Accelerator RAID Driver during Windows Setup. Refer to **Installing Software** for instructions on installing the driver during Windows Setup.
3. Install the Intel Matrix Storage Console after the operating system is installed.

To create a volume from an existing disk, complete the following steps:



### Important

*A **Create from Existing Disk** operation will delete all existing data from the added disk and the data cannot be recovered. It is critical to backup all important data on the added disk before proceeding. However, during the migration process, the data on the source disk is preserved.*

After the Intel Matrix Storage Console has been successfully installed and the system has rebooted, click on the Intel Application Accelerator shortcut link (**Start --> All Programs --> Intel Matrix Storage Manager --> Intel Matrix Storage Console**) and the following window will appear:

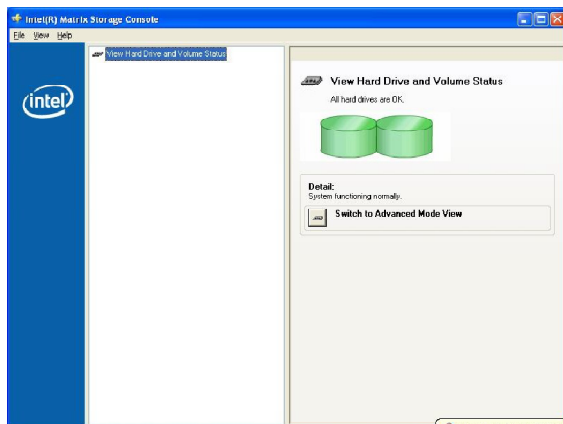

### Create RAID Volume from Existing Disk

To create a RAID volume from an existing disk, choose **Action --> Create RAID Volume from Existing Hard Drive**.

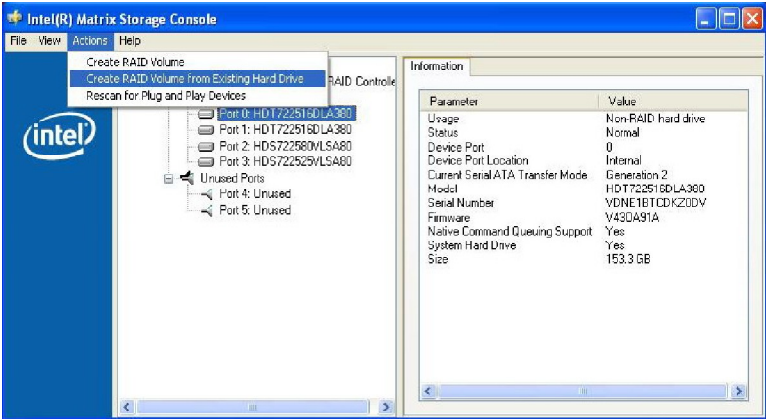

The **Create RAID Volume from Existing Hard Drive Wizard** pops up to lead you for the following procedure. Click **Next** to continue.

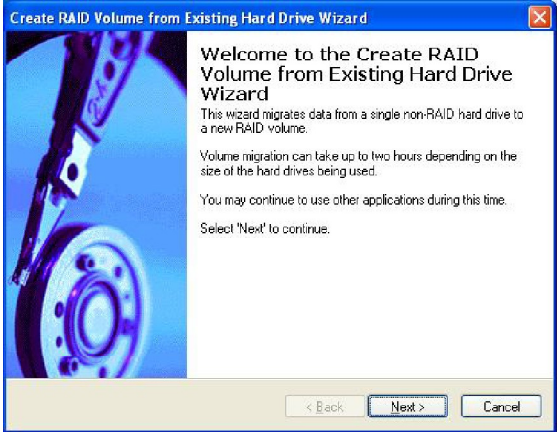

## (1) Configure Volume

Here you can configure the new RAID volume by entering the volume name, selecting the RAID level and strip size.

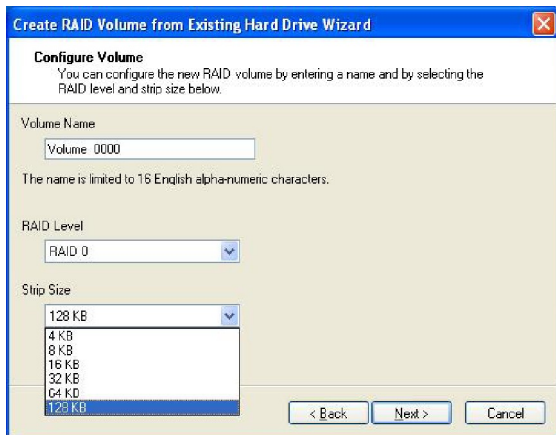

### ► RAID Volume Name:

A desired RAID volume name needs to be typed in where the 'Volume\_0000' text currently appears above. The RAID volume name has a maximum limit of 16 characters. The RAID volume name must also be in English alphanumeric ASCII characters.

### ► RAID Level:

Select the desired RAID level:

**RAID 0** (Performance) – A volume optimized for performance will allow you to access your data more quickly.

**RAID 1** (Redundancy) – A volume optimized for data redundancy will provide you with a realtime duplicate copy of your data. Note: Only half of the available volume space will be available for data storage.

**RAID 5** (Useful) – RAID 5 can be used on three or more disks, with zero or more spare-disks. The resulting RAID-5 device size will be  $(N-1)*S$ , where N is the how many drive, S is the size of the smallest drive in the array. If one of the disks fail, all data are still intact. It can rebuild the disk from the parity information. If spare disks are available, reconstruction will begin immediately after the device failure. If two disks fail simultaneously, all data are lost. RAID-5 can survive one disk failure, but not two or more. Both read and write performance usually increase, but can be hard to predict how much. Reads are similar to RAID-0 reads, writes can be either rather

expensive (requiring read-in prior to write, in order to be able to calculate the correct parity information), or similar to RAID-1 writes. The write efficiency depends heavily on the amount of memory in the machine, and the usage pattern of the array. Heavily scattered writes are bound to be more expensive.

**RAID 10 (Mirrored Stripes)** –A RAID 1 array of two RAID 0 arrays.

► **Strip Sizes:**

Select the desired strip size setting. As indicated, the optimal setting is 128KB. Selecting any other option may result in performance degradation. Even though 128KB is the recommended setting for most users, you should choose the strip size value which is best suited to your specific RAID usage model. The most typical strip size settings are:

- 4KB:** For specialized usage models requiring 4KB strips
- 8KB:** For specialized usage models requiring 8KB strips
- 16KB:** Best for sequential transfers
- 32KB:** Good for sequential transfers
- 64KB:** Good general purpose strip size
- 128KB:** Best performance for most desktops and workstations

**(2) Select the source disk**

Then select the source disk that you wish to use and then click “--->” to move it to the **Selected** field. Then click **Next** to continue.

It is very important to note which disk is the source disk (the one containing all of the information to be migrated) and which one is the target disk. On a RAID Ready system, this can be determined by making a note during POST of which port the single disk is attached to.

You can also use the Intel Application Accelerator RAID Edition utility before the second disk is installed to verify the Port and serial number of the drive that contains all the data.

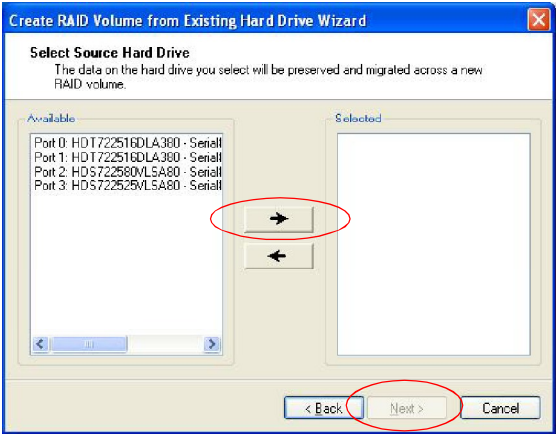

### (3) Select Member Hard Drive(s)

Then select the member disk (the target disk) that you wish to use and then click “-->” to move it to the **Selected** field. Then click **Next** to continue.

Please note that the existing data on the selected hard drive(s) will be deleted permanently. Do not forget to back up all the important data before continuing.

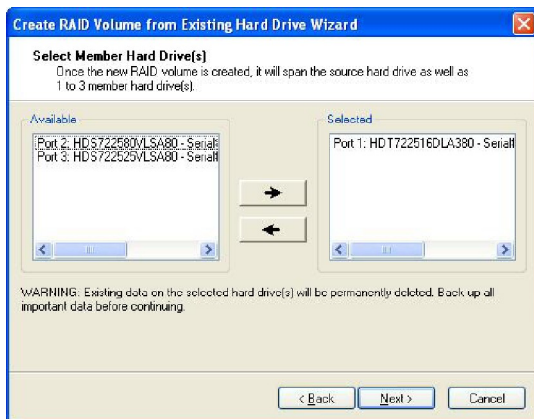
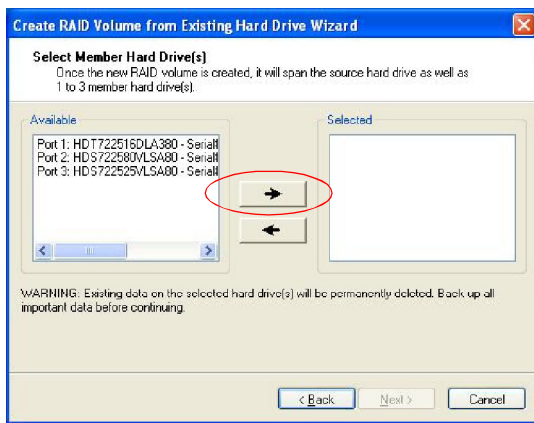

**(4) Specify Volume Size**

Specify the amount of available array space to be used by the new RAID volume. You may enter the amount in the space or use the slider to specify. It is recommended you use 100% of the available space for the optimized usage. For RAID 0 volume, if you do not specify 100% of the hard drive space, the rest hard drive space will be worked as RAID 1 volume, which is the new technology called Intel Matrix RAID. Then click **Next** to continue.

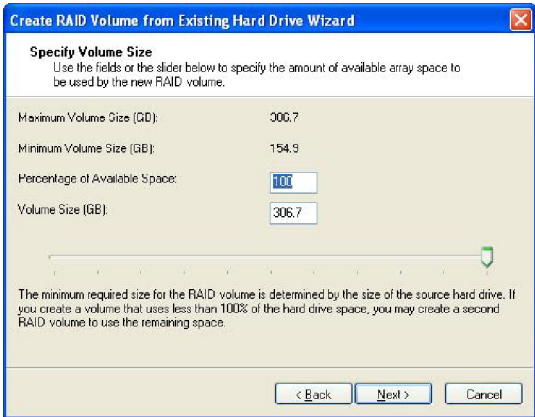

**(5) Start Creating RAID Volume from Existing Hard Drive Wizard**

Before you continue the procedure of RAID volume creation from existing hard drive, read the dialogue box below carefully. Please note that once you click **Finish**, the existing data on the selected hard drive(s) will be deleted permanently and this operation cannot be undone. It is critical that you backup all important data before selecting **Finish** to start the migration process.

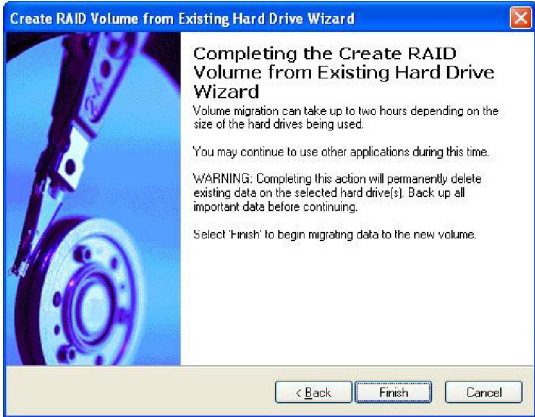

## (6) Start Migration

The migration process may take up to two hours to complete depending on the size of the disks being used and the strip size selected. A dialogue window will appear stating that the migration process may take considerable time to complete, meanwhile a popup dialogue at the taskbar will also show the migration status. While you can still continue using your computer during the migration process, once the migration process starts, it cannot be stopped. If the migration process gets interrupted and your system is rebooted for any reason, it will pick up the migration process where it left off. You will be provided with an estimated completion time (the remaining time will depend on your system) once the migration process starts.



The following screen appears if the migration process is completed successfully. Then you have to reboot your system to use the full capacity of the new volume.

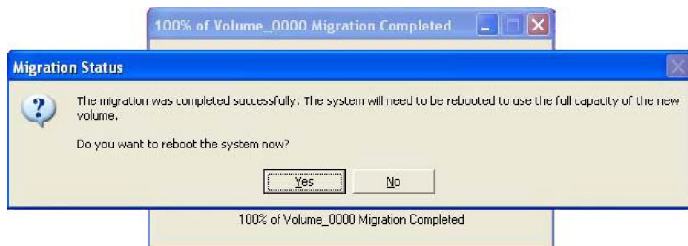

## Recovery Volume Creation

A recovery volume can be created using either Basic mode or Advanced mode in the Intel Matrix Storage Console.

### Recovery Volume in Basic Mode Creation



#### Important

***Creating a recovery volume will permanently delete any existing data on the drive selected as the recovery drive. Back up all important data before beginning these steps.***

*This option may or may not be available depending on your system configuration. If you do not see the option listed, refer to Recovery Volume Creation in Advanced Mode.*

To create a recovery volume in Basic mode, use the following steps:

- (1) Open the Intel Matrix Storage Console. (**Start --> All Programs --> Intel Matrix Storage Manager --> Intel Matrix Storage Console**)
- (2) Select Protect data using IntelR Rapid Recover Technology.

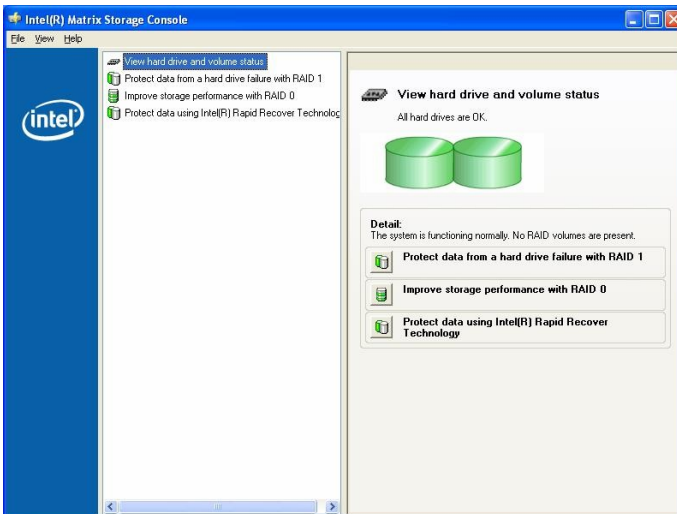

- (3) Select **Yes** to confirm volume creation.

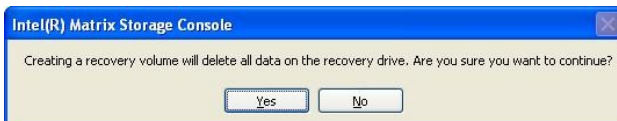

## Recovery Volume in Advanced Mode Creation



## Important

***Creating a recovery volume will permanently delete any existing data on the drive selected as the recovery drive. Back up all important data before beginning these steps.***

To create a recovery volume in Advanced mode, use the following steps:

- (1) Open the Intel Matrix Storage Console. (**Start --> All Programs --> Intel Matrix Storage Manager --> Intel Matrix Storage Console**)
- (2) Select Advanced Mode in the View menu.
- (3) Select **Create Recovery Volume** in the Actions menu.

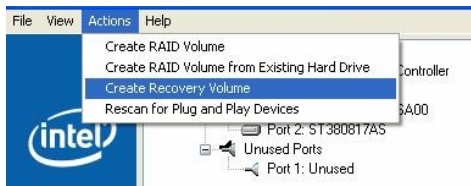

- (4) Select **Next** to continue.



- (5) Modify the recovery volume name if you wish.

- (6) Select a hard drive to be used as the master hard drive for the recovery volume.

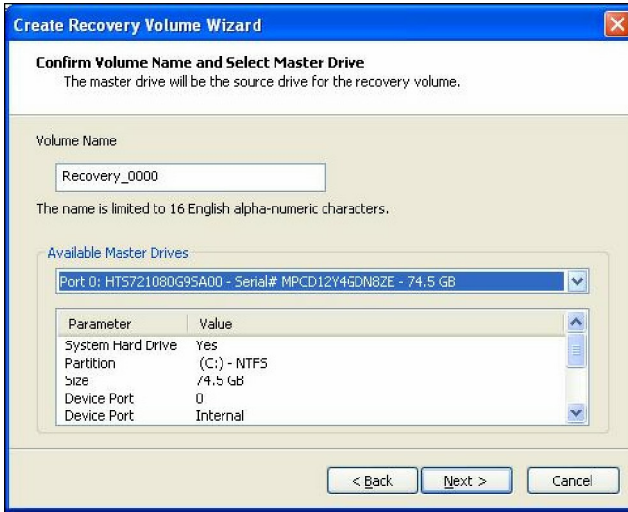

- (7) Select a hard drive to be used as the recovery hard drive for the recovery volume.

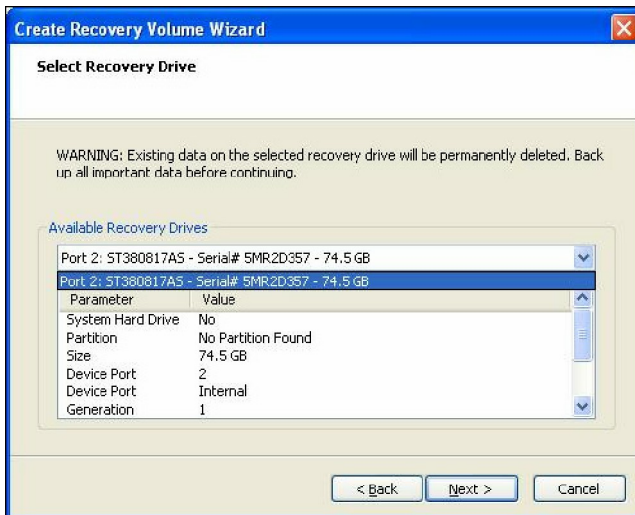

(8) Select an update policy.

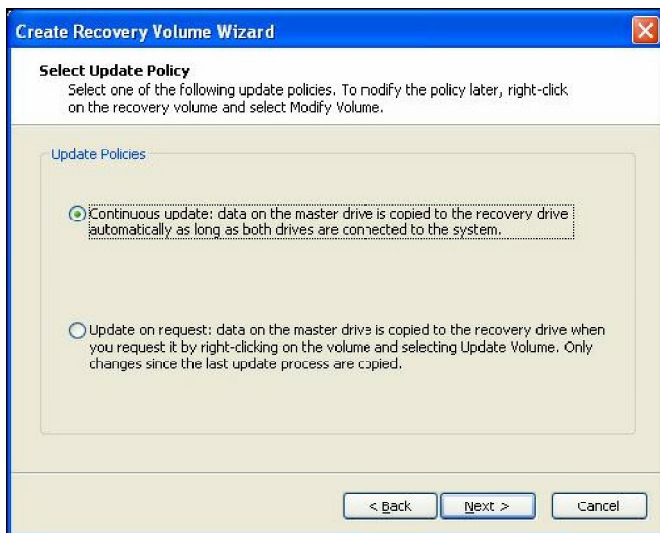

(9) Select **Finish** to begin recovery volume creation.

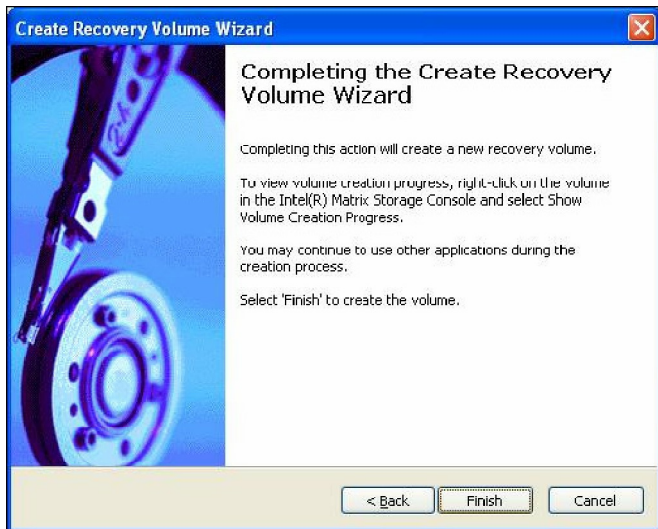

## Degraded RAID Array

A RAID 1, RAID 5 or RAID 10 volume is reported as degraded when one of its hard drive members fails or is temporarily disconnected, and data mirroring is lost. As a result, the system can only utilize the remaining functional hard drive member. To re-establish data mirroring and restore data redundancy, refer to the procedure below that corresponds to the current situation.

### Missing Hard Drive Member

1. Make sure the system is powered off.
2. Reconnect the hard drive.
3. Reboot the system to Windows; the rebuild will occur automatically.

### Failed Hard Drive Member

1. Make sure the system is powered off.
2. Replace the failed hard drive with a new one that is of equal or greater capacity.
3. Reboot the system to Intel RAID Option ROM by press <Ctrl> and <I> keys simultaneously during the Power-On Self Test (POST).

```

RAID Volumes
ID Name Level Strips Size Status Bootable
0 Volume0 RAID10(RAID0+1) 64 KB 153.4GB Degraded Yes

Physical Disks::
Port Device Model Serial # Size Type/Status(Vol ID)
0 HDS722680VLSA80 VNRB3EC20640SL 76.7GB Member Disk (0)
1 HDS722680VLSA80 VNRB3EC20559SL 76.7GB Member Disk (0)
2 HDS722680VLSA80 VNRB3EC20589SL 76.7GB Member Disk (0)
3 HDS722680VLSA80 VNRB3EC20569SL 76.7GB Non-RAID Disk

Press <CTRL-I> to enter Configuration Utility..

```

4. Select the port of the destination disk for rebuilding, and then press ENTER.

```

Copyright(C) 2003-08 Intel Corporation. All Rights Reserved.
[MAIN MENU]
[DEGRADED VOLUME DETECTED]
Degraded volume and disk available for rebuilding detected. Selecting
a disk initiates a rebuild. Rebuild completes in the operating system.

Select the port of the destination disk for rebuilding (ESC to exit):
Port Drive Model Serial # Size
0 HDS722680VLSA80 VNRB3EC20549SL 76.7GB

[↑ ↓]-Previous/Next [ENTER]-Select [ESC]-Exit
Port Device Model Serial # Size Type/Status(Vol ID)
0 HDS722680VLSA80 VNRB3EC20549SL 76.7GB Member Disk (0)
1 HDS722680VLSA80 VNRB3EC20559SL 76.7GB Member Disk (0)
2 HDS722680VLSA80 VNRB3EC20569SL 76.7GB Member Disk (0)
3 HDS722680VLSA80 VNRB3EC20579SL 76.7GB Non-RAID Disk

[↑ ↓]Change [ESC]-Previous Menu [ENTER]-Select

```

## MS-96C8 Server Board

5. Exit Intel RAID Option ROM, and then reboot to Windows system.
6. When prompted to rebuild the RAID volume, click 'Yes'.
7. The Intel(R) Storage Utility will be launched. Right-click the new hard drive and select 'Rebuild to this Disk'. The 'Rebuild Wizard' will be launched which will guide you through the process of rebuilding to the new hard drive.

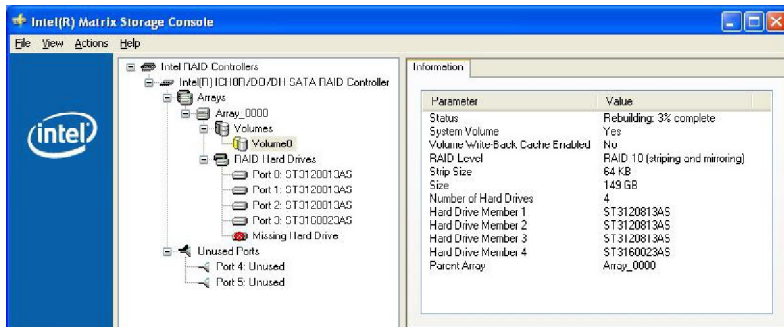

## *Appendix B*

# *LSI SAS RAID*

This appendix explains how to configure and use the components of the LSI Logic Integrated RAID (IR) software with LSI SAS 1064/1064E & 1068/1068E controllers.



## 1. Introduction to Integrated RAID

This section provides an overview of the LSI Logic Integrated RAID solution for LSI Logic SAS controllers, its features, and its benefits.

The LSI Logic Integrated RAID solution provides cost benefits for the server or workstation market where the extra performance, storage capacity, and/or redundancy of a RAID configuration are required. The two components of Integrated RAID are:

- ▶ **Integrated Mirroring (IM)**, which provides features of RAID 1 and RAID 1E (RAID 1 Enhanced). RAID 1E is also called *Integrated Mirroring Enhanced (IME)*
- ▶ **Integrated Striping (IS)**, which provides features of RAID 0

By simplifying the IM and IS configuration options and by providing firmware support in its host adapters, LSI Logic can offer the Integrated RAID solution at a lower cost than a hardware RAID implementation.

Fusion-MPT™ firmware supports IM and IS volumes. You can configure IM and IS volumes together on the same LSI Logic SAS controller.

### Integrated RAID Benefits and Features

- ▶ Low cost RAID volume creation meets the needs of most internal RAID installations
- ▶ Easy to use - installation and configuration are not complex
- ▶ System can boot from an IM, IME, or IS volume
- ▶ No special OS-specific software required
- ▶ High reliability and data integrity
  - Non-volatile write journaling
  - Physical disks not visible to OS or to application software
- ▶ Low host CPU and PCI bus utilization
- ▶ Fusion-MPT architecture provides processing power
  - Shared memory architecture minimizes external memory requests
  - Functionality is contained in device hardware and firmware

## 2. Integrated Mirroring Overview

This section provides an overview of the LSI Logic Integrated Mirroring (IM) feature.

### 2.1 Introduction

As a result of the shift towards Network Attached Storage (NAS), ISPs need a cost effective, fault-tolerant solution to protect the operating systems on small form factor, high-density, rack-mountable servers. The LSI Logic Integrated Mirroring (IM) feature—which includes Integrated Mirroring Enhanced (IME)—provide data protection for the system boot volume to safeguard critical information such as the operating system on servers and high performance workstations. The Integrated Mirroring feature gives customers a robust, high-performance, fault-tolerant solution to their storage needs, at a lower cost than a dedicated RAID controller.

The Integrated Mirroring feature supports simultaneous mirrored volumes with two disks (IM) or three to eight disks (IME), to provide fault-tolerant protection for critical data. (If a hot spare disk is used, the maximum volume size is seven mirrored disks, plus the hot spare disk.) Up to two IM volumes are supported per SAS controller, with up to ten drives total per controller.

- ❖ Note: Ten disk drives is the theoretical upper limit, although the SAS controller itself may support fewer drives.

If a disk in an Integrated Mirroring volume fails, the hot swap capability allows the volume to be easily restored by simply swapping disks. The firmware then automatically re-mirrors the swapped disk. Additionally, each SAS controller can have one global hot spare disk available to automatically replace a failed disk in the one or two IM or IME volumes configured on the controller. The hot spare makes the Integrated Mirroring volume even more fault-tolerant.

- ❖ Note: You can configure an Integrated Mirroring volume and an Integrated Striping volume on the same LSI Logic SAS controller.

The IM feature uses the same device drivers as the standard LSI Logic Fusion-MPT based controllers, providing seamless and transparent fault tolerance. This eliminates the need for complex backup software or expensive RAID hardware. The IM feature operates independently from the operating system, in order to conserve system resources. The BIOSbased configuration utility makes it easy to configure IM and IME volumes.

The Integrated Mirroring feature is currently available as an optional component of the Fusion-MPT architecture on LSI Logic controller products.

## **2.2 IM Features**

LSI Logic Integrated Mirroring and Integrated Mirroring Enhanced support the following features:

- ▶ Configurations of one or two IM or IME volumes on the same LSI Logic SAS controller. Each volume can consist of two mirrored disks (IM) or three to eight mirrored disks (IME).
- ▶ (Optional) One global hot spare disk per controller. If a global hot spare disk is defined, the upper limit for an IME volume is seven mirrored disks.
- ▶ Mirrored volumes run in optimal mode or in degraded mode (if one mirrored disk fails)
- ▶ Hot swap capability
- ▶ Presents a single virtual drive to the OS for each IM/IME volume
- ▶ Supports both SAS and SATA disks, although the two types of disks cannot be combined on the same LSI Logic SAS controller
- ▶ Fusion-MPT architecture
- ▶ Easy-to-use BIOS-based configuration utility (and DOS-based configuration utility for manufacturing use only)
- ▶ Error notification: OS-specific event log updated by drivers and errors displayed inside the Fusion-MPT BIOS
- ▶ SES status LED support for Integrated Mirroring disks
- ▶ Write journaling, which allows automatic synchronization of potentially inconsistent data after unexpected power-down situations
- ▶ Metadata used to store volume configuration on mirrored disks
- ▶ Automatic background resynchronization while host I/Os continue
- ▶ Background media verification ensures that data on the IM volume is accessible

### 2.3 IM/IME Description

The LSI Logic Integrated Mirroring (IM) feature supports one or two mirrored volumes on each LSI Logic SAS controller (or one mirrored volume and one Integrated Striping volume). Typically, one of these volumes is the boot volume, as shown in Figure 2.1. This is accomplished through the firmware of the LSI Logic SAS controller that supports the standard Fusion-MPT interface. The runtime mirroring of the boot disk is transparent to the BIOS, drivers, and operating system.

Host-based status software monitors the state of the mirrored disks and reports any error conditions. In Figure 2.1 the system is configured with a second disk as a mirror of the first (primary) disk.

Figure 2.1 Typical Integrated Mirroring Implementation

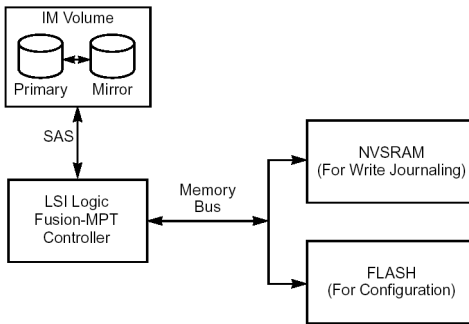

The advantage of Integrated Mirroring (RAID 1), is that there is always a mirrored copy of the data. The disadvantage is that writes take longer because data must be written twice. On the other hand, performance is actually improved during reads. Figure 2.2 shows the logical view and physical view of an Integrated Mirroring configuration with two disks in the mirrored volume.

Figure 2.2 Integrated Mirroring with Two Disks

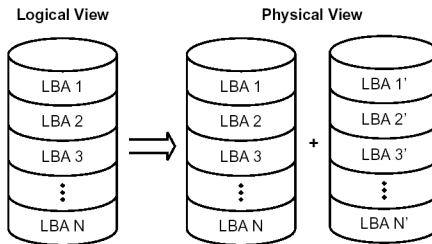

An IME volume can be configured with up to eight mirrored disks, or seven mirrored disks and a global hot spare. Figure 2.3 shows the logical view and physical view of an Integrated Mirroring Enhanced (IME) volume with three mirrored disks. Each *mirrored stripe* is written to a disk and mirrored to an adjacent disk. This type of configuration is also called RAID 1E.

**Figure 2.3 Integrated Mirroring with More than Two Disks (IME)**

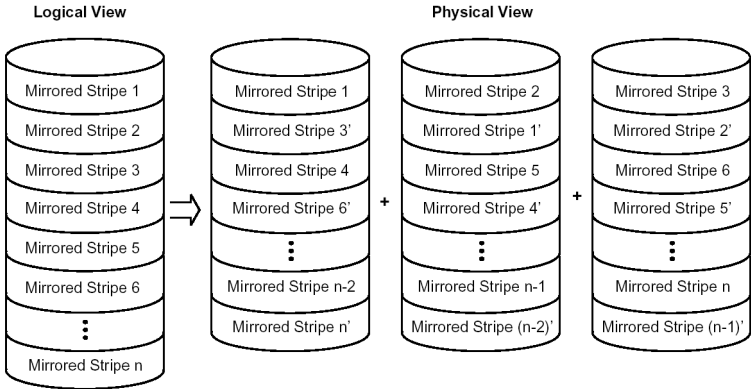

LSI Logic provides the BIOS-based configuration utility to enable the user to create IM and IME volumes during initial setup and to reconfigure them in response to hardware failures or changes in the environment.

## 2.4 Integrated Mirroring Firmware

This section describes features of the LSI Logic Integrated Mirroring (IM) firmware, which supports up to two IM volumes per LSI Logic SAS controller.

### 2.4.1 Host Interface

The IM host interface uses the Message Passing Interface, as described in the *Fusion-MPT Message Passing Interface Specification*. Through the Fusion-MPT interface, the host OS has access to the IM volume as well as the physical disks.

### 2.4.2 Resynchronization with Concurrent Host I/O Operation

The IM firmware allows Host I/Os to continue on the IM/IME volume while the volume is being re-synchronized in the background. Resynchronization is attempted after a hot spare is activated due to a physical device failure, or after a hot swap has occurred to a physical disk in the IM or IME volume.

### 2.4.3 Metadata Support

The firmware supports metadata, which describes the IM/IME logical drive configuration stored on each member disk. When the firmware is initialized, each member disk is queried to read the stored metadata in order to verify the configuration. The usable disk space for each member disk is adjusted down to leave room for this data.

### 2.4.4 Hot Swapping

The IM firmware supports *hot swapping*. The hot-swapped disk is automatically resynchronized in the background, without any host or user intervention. The firmware detects hot swap removal and disk insertion.

Following a hot swap event, the firmware readies the new physical disk by spinning it up and verifying that it has enough capacity for the mirrored volume. The IM firmware resynchronizes all hot-swapped disks that have been removed, even if the same disk is re-inserted. In a two-disk mirrored volume, the IM firmware marks the hot-swapped disk as the secondary disk and marks the other mirrored disk as the primary disk. The firmware resynchronizes all data from the primary disk onto the new secondary disk.

### 2.4.5 SMART Support

The IM firmware enables Mode 6 SMART on the member disks in the mirrored volume. Mode 6 SMART requires each physical disk to be polled at regular intervals. If a SMART ASC/ASCQ code is detected on a physical disk in the volume, the firmware processes the SMART data, and the last received SMART ASC/ASCQ is stored in non-volatile memory. The IM/IME volume does not support SMART directly, since it is just a logical representation of the physical disks in the volume.

### 2.4.6 Hot Spare Disk

One disk can be configured as a *global hot spare* disk, which protects data on the one or two volumes configured on the controller. If the IM firmware fails one of the mirrored disks, the firmware automatically replaces it with the hot spare

disk. The IM firmware then resynchronizes the mirrored data. The IM firmware is automatically notified when the failed disk has been replaced, and the firmware then designates that disk as the new hot spare.

### **2.4.7 Media Verification**

The IM firmware supports a background *media verification feature* that runs at regular intervals when the IM/IME volume is in optimal mode. If the verification command fails for any reason, the other disk's data for this segment is read and written to the failing disk in an attempt to refresh the data. The current Media Verification Logical Block Address is written to non-volatile memory occasionally to allow Media Verification to continue approximately where it left off prior to a power-cycle.

### **2.4.8 Disk Write Caching**

The IM firmware disables disk write caching by default. This is done to increase data integrity, so that the disk write log stored in NVSRAM is always valid. If disk write caching were enabled (not recommended), the disk write log could be invalid.

### **2.4.9 NVSRAM Usage**

For the LSISAS1064/1064E and LSISAS1068/1068E controllers, the IM firmware requires at least a 32K NVSRAM in order to perform write journaling. Write journaling is used to verify that the mirrored disks in the IM/IME volume are synchronized with each other.

## **2.5 Fusion-MPT Support**

The BIOS uses the LSI Logic Fusion-MPT interface to communicate to the SAS controller and firmware to enable Integrated Mirroring. This includes reading the Fusion-MPT configuration to gain access to the parameters that are used to define behavior between the SAS controller and the devices connected to it. The Fusion-MPT drivers for all supported operating systems implement the Fusion-MPT interface to communicate with the controller and firmware.

## 3. Creating Integrated Mirroring Volumes

This section describes how to create Integrated Mirroring (IM) and Integrated Mirroring Enhanced (IME) volumes using the LSI Logic SAS BIOS Configuration Utility (SAS BIOS CU).

### 3.1 IM Configuration Overview

You can use the SAS BIOS CU to create one or two IM or IME volumes on each LSI Logic SAS controller, with an optional global hot spare disk. All disks in an IM or IME volume must be connected to the same LSI Logic SAS controller.

Although you can use disks of different size in IM and IME volumes, the smallest disk determines the "logical" size of each disk in the volume. In other words, the excess space of the larger member disk is not used.

Refer to Section 2.2, "IM Features," for more information about Integrated Mirroring volumes.

### 3.2 Creating IM and IME Volumes

The SAS BIOS CU is part of the Fusion-MPT BIOS. When the BIOS loads during boot and you see the message about the LSI Logic Configuration Utility, press **Ctrl-C** to start the CU. After you do this, the message changes to:

***Please wait, invoking SAS Configuration Utility...***

After a brief pause, the main menu of the SAS BIOS CU appears. On some systems, however, the following message appears next:

***LSI Logic Configuration Utility will load following initialization!***

In this case, the SAS BIOS CU will load after the system has completed its power-on self test.

You can configure one or two IM or IME volumes per Fusion-MPT controller. You can also combine IM, IME, and Integrated Striping volumes on the same controller, up to a maximum of 10 physical disk drives.

The following guidelines also apply when creating an IM or IME volume:

- ▶ All physical disks in the volumes must be either SATA (with extended command set support) or SAS (with SMART support). SAS and SATA disks *cannot* be combined in the same volume.
- ▶ Disks must have 512-byte blocks and must not have removable media.
- ▶ An IM volume must have two drives, plus an optional global hot spare. An IME volume. An IME volume can have three to eight drives, or three to seven drives if you also create a global hot spare.

❖ Note: If a disk in an IM or IME volume fails, it is rebuilt on the global hot spare if one

is available. So adding a global hot spare greatly increases the level of data protection. (One global hot spare is allowed for the one or two volumes configured on a controller.)

### 3.2.1 Creating an IM Volume

Follow these steps to create an IM volume with the SAS BIOS CU:

1. On the Adapter List screen, use the arrow keys to select an LSI Logic SAS adapter.
2. Press **Enter** to go to the Adapter Properties screen, shown in Figure 3.1.

Figure 3.1 Adapter Properties Screen

```

LSI Logic MPT Setup Utility   v6.01.03.00
Adapter Properties -- SAS1068

Adapter                      SAS1068
PCI Slot                      03
PCI Address(Bus/Dev/Func)    03:00:00
MPT Firmware Revision        00.03.23.00-IT
SAS Address                   500605B0:0000C580
Status                        Enabled
Boot Order                    1
Boot Support                   [Enabled BIOS & OS]

RAID Properties

SAS Topology

Advanced Adapter Properties

Esc = Exit Menu           F1/Shift+1 = Help
Enter = Select Item      -/+ = Change Item
  
```

3. On the Adapter Properties screen, use the arrow keys to select **RAID Properties** on the screen and press **Enter**.
4. When you are prompted to select a volume type, select **Create IM Volume**. The Create New Array screen shows a list of disks that can be added to a volume.
5. Move the cursor to the "RAID Disk" column and select a disk. To add the disk to the volume, change the "No" to "Yes" by pressing the + key, . key, or space bar. When the first disk is added, the SAS BIOS CU prompts you to either keep existing data or overwrite existing data.
6. Press **M** to keep the existing data on the first disk or press **D** to overwrite it. If you keep the existing data, this is called a *migration*. The first disk will be mirrored onto the second disk, so the data you want to keep *must* be on the first disk added to the volume. Any data on the second disk is overwritten. As disks are added the Array Size field changes to reflect the size of the new volume.
7. (optional) Add a global hot spare by moving the cursor to the hot spare column and pressing the + key, . key, or space bar.

Figure 3.2 shows an IM volume configured with a global hot spare disk.

**Figure 3.2 Create New Array Screen**

```

LSI Logic MPT Setup Utility   v6.01.03.00
Create New Array -- SAS1068

  Array Type:                  IM
  Array Size (MB)              34332

Slot  Device Identifier          RAID  Hot  Drive  Pred  Size
Num   Device Identifier          Disk  Spr  Status Fail  (MB)
  1   MAXTOR ATLAS15K2_36SAS BG34  [Yes] [No]  Primary --- 35074
  2   MAXTOR ATLAS15K2_36SAS BG34  [Yes] [No]  Secondary --- 35074
  8   MAXTOR ATLAS15K2_36SAS BG34  [No]  [Yes] Hot Spare --- 35074
 11   MAXTOR ATLAS15K2_36SAS BG34  [No]  [No]  Max Dsks --- 35074

Esc = Exit Menu           F1/Shift+1 = Help
Space/+/- = Select disk for array or hot spare   C = Create array

```

- When the volume has been fully configured, press **C** and then select **Save changes then exit this menu** to commit the changes. The SAS BIOS CU pauses while the array is being created.

### **3.2.2 Creating an IME Volume**

Follow these steps to create an IME volume with the SAS BIOS CU:

- On the Adapter List screen, use the arrow keys to select an LSI Logic SAS adapter.
- Press **Enter** to go to the Adapter Properties screen, shown in Figure 3.1.
- On the Adapter Properties screen, use the arrow keys to select **RAID Properties** on the screen and press **Enter**.
- When you are prompted to select a volume type, select **Create IME Volume**. The Create New Array screen shows a list of disks that can be added to a volume.
- Move the cursor to the "RAID Disk" column and select a disk. To add the disk to the volume, change the "No" to "Yes" by pressing the + key, . key, or space bar.
- Repeat this step to select a total of three to eight disks for the volume (or three to seven disks if you will create a global hot spare). All existing data on all the disks you select will be overwritten. As you add disks, the Array Size field changes to reflect the size of the new volume.
- (optional) Add a global hot spare to the volume by moving the cursor to the hot spare column and pressing the + key, . key, or space bar.
- When the volume has been fully configured, press **C** and then select **Save changes then exit this menu** to commit the changes. The SAS BIOS CU pauses while the array is being created.

### 3.3 Creating a Second IM or IME Volume

The LSI Logic SAS controllers allow you to configure two IM or IME volumes. If one volume is already configured, and if there are available disk drives, there are two ways to add a second volume.

The first is as follows:

1. In the configuration utility, select an adapter from the Adapter List. Select the **RAID Properties** option. This will display the current volume.
2. Press **C** to create a new volume.
3. Continue with step 4 of the IM or IME creation procedure in the previous section to create a second volume.

The other way in which to add a second volume is as follows:

1. On the Adapter List screen, use the arrow keys to select an LSI Logic SAS adapter.
2. Press **Enter** to go to the Adapter Properties screen, shown in Figure 3.1.
3. On the Adapter Properties screen, use the arrow keys to select **RAID Properties** and press **Enter**.
4. Continue with step 4 of the IM or IME creation procedure in the previous section to create a second volume.

### 3.4 Managing Hot Spares

You can create one global hot spare disk to protect the one or two IM/IME volumes defined on a SAS controller. Usually, you create the global hot spare at the same time you create the IM/IME volume. Follow these steps to add a global hot spare disk later for the existing IM/IME volumes on the controller:

1. On the View Array screen, select **Manage Array**.
2. Select **Manage Hot Spare** on the Manage Array screen, shown in Figure 3.3.

**Figure 3.3 Manage Array Screen**

```

LSI Logic MPT Setup Utility   v6.01.03.00
Manage Array -- SAS1068

Identifier                    LSILOGICLogical Volume 3000
Type                          IM
Scan Order                    1
Size (MB)                    34332
Status                        Optimal

Manage Hot Spare

Synchronize Array

Activate Array

Delete Array

Esc = Exit Menu             F1/Shift+1 = Help
Enter = Choose array type to create   Esc = Return to Adapter Properties

```

3. Select a disk from the list by pressing the + key, . key, or space bar.
4. After you select the global hot spare disk, press **C**. An error message appears if the selected disk is not at least as large as the smallest disk used in the IM/IME volume(s). The global hot spare disk must have 512-byte blocks, it cannot have removable media, and the disk type must be either SATA with extended command set support or SAS with SMART support. If SATA disks are used for the IM/IME volume(s), the hot spare disk must also be a SATA disk. If SAS disks are used, the hot spare disk must also be a SAS disk. An error message appears if the selected disk is not the same type as the disks used in the IM/IME volumes.
5. Select **Save changes then exit this menu** to commit the changes. The configuration utility will pause while the global hot spare is being added.

Follow these steps to delete a global hot spare:

1. Select **Manage Hot Spare** on the Manage Array screen.
2. Select **Delete Hot Spare** and then press **C**.
3. Select **Save changes then exit this menu** to commit the changes. The configuration utility will pause while the global hot spare is being removed.

## 3.5 Other Configuration Tasks

This section explains how to do other tasks related to configuring and maintaining IM and IME volumes.

### 3.5.1 Viewing Volume Properties

Follow these steps to view the properties of volumes:

1. In the SAS BIOS CU, select an adapter from the Adapter List. Select the **RAID Properties** option. The properties of the current volume are displayed. If a global hot spare is defined, it is also listed.
  - ❖ Note: If you create one volume using SAS disks, another volume using SATA disks, and a global hot spare disk, the hot spare disk will only appear when you view the volume that has the same type of disks as the hot spare disk.
2. If two volumes are configured, press **Alt+N** to view the other array.
3. To manage the current array, select the **Manage Array** item and press **Enter**.

### 3.5.2 Synchronizing an Array

The Synchronize Array command forces the firmware to resynchronize the data on the mirrored disks in the array. It is seldom necessary to use this command, because the firmware automatically keeps the mirrored data synchronized during normal system operation. When you use this command, one disk of the array is placed in the *Degraded* state until the data on the mirrored disks has been resynchronized.

Follow these steps to force the synchronization of a selected array:

1. Select **Synchronize Array** on the Manage Array screen.
2. Press **Y** to start the synchronization, or **N** to cancel it.

### 3.5.3 Activating an Array

An array can become inactive if, for example, it is removed from one controller or computer and moved to another one. The “Activate Array” option allows you to reactivate an inactive array that has been added to a system. This option is only available when the selected array is currently inactive.

Follow these steps to activate a selected array

1. Select **Activate Array** on the Manage Array screen.
2. Press **Y** to proceed with the activation, or press **N** to abandon it. After a pause, the array will become active.
  - ❖ Note: If there is a global hot spare disk on the controller to which you have moved the array, the firmware checks when you activate the array to determine if the hot spare is compatible with the new array. An error message appears if the disks in the activated array are larger than the hot spare disk or if the disks in the activated array are not the same type as the hot spare disk (SATA versus SAS).

### 3.5.4 Deleting an Array

❖ **CAUTION:** Before deleting an array, be sure to back up all data on the array that you want to keep.

Follow these steps to delete a selected array:

1. Select **Delete Array** on the Manage Array screen.
  2. Press **Y** to delete the array.
    - After a pause, the firmware deletes the array. If there is another remaining array and a global hot spare disk, the firmware checks the hot spare disk to determine if it is compatible with the remaining array. If the hot spare disk is not compatible (too small or wrong disk type) the firmware deletes it also.
- ❖ Note: After a volume has been deleted, it cannot be recovered. When a RAID 1 volume is deleted, the data is preserved on the primary disk. The master boot records (MBR) of other disks in the array are deleted. For other RAID types, the master boot records of all disks are deleted.

### **3.5.5 Locating a Disk Drive, or Multiple Disk Drives in a Volume**

You can use the SAS BIOS CU to locate and identify a specific physical disk drive by flashing the drive's LED. You can also use the SAS BIOS CU to flash the LEDs of all the disk drives in a RAID volume. There are several ways to do this:

- ▶ When you are creating an IM or IME volume, and a disk drive is set to **Yes** as part of the volume, the LED on the disk drive is flashing. The LED is turned off when you have finished creating the volume.
  - ▶ You can locate individual disk drives from the SAS Topology screen. To do this, move the cursor to the name of the disk in the Device Identifier column and press **Enter**. The LED on the disk flashes until the next key is pressed.
  - ▶ You can locate all the disk drives in a volume by selecting the volume on the RAID Properties screen. The LEDs flash on all disk drives in the volume.
- ❖ Note: The LEDs on the disk drives will flash as described above if the firmware is correctly configured and the drives or the disk enclosure supports disk location.

### **3.5.6 Selecting a Boot Disk**

You can select a boot disk in the SAS Topology screen. This disk is then moved to scan ID 0 on the next boot, and remains at this position. This makes it easier to set BIOS boot device options and to keep the boot device constant during device additions and removals. There can be only one boot disk.

Follow these steps to select a boot disk:

1. In the SAS BIOS CU, select an adapter from the Adapter List.
  2. Select the **SAS Topology** option.
    - The current topology is displayed. If the selection of a boot device is supported, the bottom of the screen lists the Alt+B option. This is the key for toggling the boot device. If a device is currently configured as the boot device, the Device Info column on the SAS Topology screen will show the word "Boot."
  3. To select a boot disk, move the cursor to the disk and press **Alt+B**.
  4. To remove the boot designator, move the cursor down to the current boot disk and press **Alt+B**. This controller will no longer have a disk designated as boot.
  5. To change the boot disk, move the cursor to the new boot disk and press **Alt+B**. The boot designator will move to this disk.
- ❖ Note: The firmware must be configured correctly in order for the Alt+B feature to work.

## 4. Integrated Striping Overview

This section provides an overview of the LSI Logic Integrated Striping (IS) feature.

### 4.1 Introduction

The LSI Logic Integrated Striping (IS) feature is useful for applications that require the faster performance and increased storage capacity of striping. The low-cost IS feature has many of the advantages of a more expensive RAID striping solution. A single IS logical drive may be configured as the boot disk or as a data disk.

The IS feature is implemented with controller firmware that supports the Fusion-MPT Interface. IS provides better performance and more capacity than individual disks, without burdening the host CPU. The firmware splits host I/Os over multiple disks and presents the disks as a single logical drive. In general, striping is transparent to the BIOS, the drivers, and the operating system.

The SAS BIOS CU is used to configure IS volumes, which can consist of two to eight disks.

- ❖ Note: Integrated Mirroring and Integrated Striping volumes can be configured on the same LSI logic SAS controller.

### 4.2 IS Features

Integrated Striping supports the following features:

- ▶ Support for volumes with two to eight drives
- ▶ Support for two IS volumes, with up to 10 drives total, on a controller. An IS volume can also be combined with an IM or IME volume.
- ❖ Note: Currently available LSI Logic SAS controllers support a maximum of eight drives. All drives in a volume must be connected to the same SAS controller.
- ▶ Presents a single virtual drive to the OS for each configured volume
- ▶ Support for both SAS and SATA drives, although the two types of drives cannot be combined in one volume
- ▶ Fusion-MPT architecture
- ▶ Easy-to-use SAS BIOS configuration utility
- ▶ Error notification
- ▶ Use of metadata to store volume configuration on disks
- ▶ OS-specific event log
- ▶ Error display inside the Fusion-MPT BIOS
- ▶ SES status LED support for drives used in IS volumes

### 4.3 IS Description

The IS feature writes data across multiple disks instead of onto one disk. This is accomplished by partitioning each disk's storage space into 64 Kbyte stripes. These stripes are interleaved round-robin, so that the combined storage space is composed alternately of stripes from each disk.

For example, as shown in Figure 4.1, segment 1 is written to disk 1, segment 2 is written to disk 2, segment 3 is written to disk 3, and so on. When the system reaches the end of the disk list, it continues writing data at the next available segment of disk 1.

Figure 4.1 Integrated Striping Example

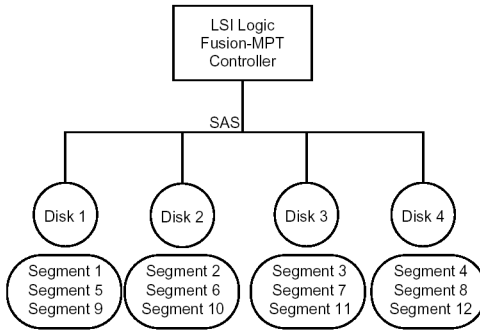
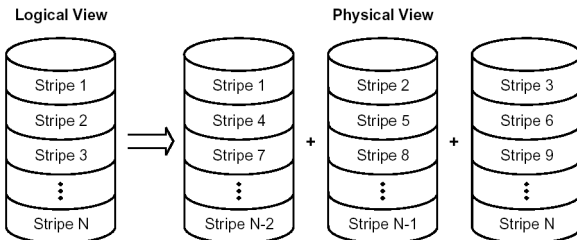

Figure 4.2 shows a logical view and a physical view of Integrated Striping configuration.

Figure 4.2 Integrated Striping - Logical and Physical Views



The primary advantage of IS is speed, because it transfers data to or from multiple disks at once. However, there is no data redundancy; therefore, if one disk fails, that data is lost.

## 4.4 Integrated Striping Firmware

This section describes features of the LSI Logic Integrated Striping (IS) firmware.

### 4.4.1 Host Interface

The IS host interface uses the Message Passing Interface, as described in the *Fusion-MPT Message Passing Interface Specification*, including Integrated Striping. Through the Fusion-MPT interface, the host operating system has access to the logical IS drive as well as the physical disks.

### 4.4.2 Metadata Support

The firmware supports metadata, which describes the IS logical drive configuration stored on each member disk. When the firmware is initialized, each member disk is queried to read the stored metadata to verify the configuration. The usable disk space for each IS member disk is adjusted down to leave room for this data.

### 4.4.3 SMART Support

The IS firmware enables Mode 6 SMART on the IS member disks. Mode 6 SMART requires each physical disk to be polled at regular intervals. If a SMART ASC/ASCQ code is detected on a physical IS disk, the firmware processes the SMART data, and the last received SMART ASC/ASCQ is stored in non-volatile memory. The IS volume does not support SMART directly, since it is just a logical representation of the physical disks in the volume.

### 4.4.4 Disk Write Caching

Disk write caching is disabled by default on all IS volumes.

## 4.5 Fusion-MPT Support

The BIOS uses the LSI Logic Fusion-MPT interface to communicate to the SAS controller and firmware to enable Integrated Striping. This includes reading the Fusion-MPT configuration to gain access to the parameters that are used to define behavior between the SAS controller and the devices connected to it. The Fusion-MPT drivers for all supported operating systems implement the Fusion-MPT interface to communicate with the controller and firmware.

## 5. Creating Integrated Striping Volumes

This section describes how to create Integrated Striping (IS) volumes using the LSI Logic SAS BIOS Configuration Utility (SAS BIOS CU).

### 5.1 IS Configuration Overview

You can use the SAS BIOS CU to create multiple IS volumes, with up to 10 drives total on an LSI Logic SAS controller. Each volume can have from 2 to 8 drives. Disks in an IS volume must be connected to the same LSI Logic SAS controller, and the controller must be in the BIOS boot order.

Although you can use disks of different size in IS volumes, the smallest disk determines the "logical" size of each disk in the volume. In other words, the excess space of the larger member disk is not used. Usable disk space for each disk in an IS volume is adjusted down to leave room for metadata. Usable disk space may be further reduced to maximize the ability to interchange disks in the same size classification. The supported stripe size is 64 Kbytes.

Refer to Section 4.2, "IS Features," for more information about Integrated Striping volumes.

### 5.2 Creating IS Volumes

The SAS BIOS CU is part of the Fusion-MPT BIOS. When the BIOS loads during boot and you see the message about the Setup Utility, press **Ctrl-C** to start it. After you do this, the message changes to:

***Please wait, invoking SAS Configuration Utility...***

After a brief pause, the main menu of the SAS BIOS CU appears. On some systems, however, the following message appears next:

***LSI Logic Configuration Utility will load following initialization!***

In this case, the SAS BIOS CU will load after the system has completed its power-on self test.

Follow the steps below to configure an Integrated Striping (IS) volume with the SAS BIOS CU. The procedure assumes that the required controller(s) and disks are already installed in the computer system. You can configure both IM and IS volumes on the same SAS controller.

1. On the Adapter List screen of the SAS BIOS CU, use the arrow keys to select a SAS adapter.

2. Press **Enter** to go to the Adapter Properties screen, shown in Figure 5.1.

**Figure 5.1 Adapter Properties Screen**

```
LSI Logic MPT Setup Utility   v6.01.03.00
Adapter Properties -- SAS1068

Adapter                      SAS1068
PCI Slot                      03
PCI Address (Bus/Dev/Func)   03:00:00
MPT Firmware Revision       00.03.23.00-IT
SAS Address                   500605B0:0000C580
Status                       Enabled
Boot Order                    1
Boot Support                  [Enabled BIOS & OS]

RAID Properties

SAS Topology

Advanced Adapter Properties

Esc = Exit Menu             F1/Shift+1 = Help
Enter = Select Item         -/+ = Change Item
```

3. On the Adapter Properties screen, use the arrow keys to select **RAID Properties** on the screen and press **Enter**.
4. When you are prompted to select a volume type, select **Create IS Volume**. The Create New Array screen shows a list of disks that can be added to a volume.
5. Move the cursor to the "RAID Disk" column. To add a disk to the volume, change the "No" to "Yes" by pressing the + key, . key, or space bar. As disks are added, the Array Size field changes to reflect the size of the new volume.

There are several limitations when creating an IS (RAID 0) volume:

- All disks must be either SATA (with extended command set support) or SAS (with SMART support).
- Disks must have 512-byte blocks and must not have removable media.
- There must be at least 2 and no more than 8 drives in a valid IS volume. Hot spare drives are not allowed.

Figure 5.2 shows an IS volume configured with two drives.

**Figure 5.2 Create New Array Screen**

```

LSI Logic MPT Setup Utility      v6.01.03.00
Create New Array -- SAS1068

  Array Type:                      IS
  Array Size(MB)                   70032

Slot  Device Identifier            RAID  Hot   Drive   Pred   Size
Num                                     Disk Spr  Status Fail  (MB)
  1  MAXTOR ATLAS15K2_36SAS BG34   [Yes] [No]  Ok     ---  35074
  2  MAXTOR ATLAS15K2_36SAS BG34   [Yes] [No]  Ok     ---  35074
  8  MAXTOR ATLAS15K2_36SAS BG34   [No]  [No]  Ok     ---  35074
 11  MAXTOR ATLAS15K2_36SAS BG34   [No]  [No]  Ok     ---  35074

Esc = Exit Menu      Fl/Shift+1 = Help
Space/+/- = Select disk for array or hot spare      C = Create array

```

6. When the volume has been fully configured, press **C** and then select **Save changes then exit this menu** to commit the changes. The configuration utility will pause while the array is being created.

❖ Note: Integrated Striping does not provide any data protection in the event of disk failure. It is primarily used to increase speed.

### 5.3 Creating a Second IS Volume

The LSI Logic SAS controllers allow you to configure two IS volumes, or an IS volume and an IM or IME volume. If one volume is already configured, and if there are available disk drives, there are two ways to add a second volume.

The first is as follows:

1. In the configuration utility, select an adapter from the Adapter List. Select the **RAID Properties** option. This will display the current volume.
2. Press **C** to create a new volume.
3. Continue with step 4 of Section 5.2, "Creating IS Volumes," to create a second IS volume.

The other way in which to add a second volume is as follows:

1. On the Adapter List screen, use the arrow keys to select an LSI Logic SAS adapter.
2. Press **Enter** to go to the Adapter Properties screen, shown in Figure 5.1.

3. On the Adapter Properties screen, use the arrow keys to select **RAID Properties** and press **Enter**.
4. Continue with step 4 of the IS creation procedure in the previous section to create a second volume.

## 5.4 Other Configuration Tasks

This section explains how to do other tasks related to configuring and maintaining IS volumes.

### 5.4.1 Viewing IS Volume Properties

Follow these steps to view the properties of IS volumes:

1. In the configuration utility, select an adapter from the Adapter List. Select the **RAID Properties** option. The properties of the current volume are displayed.
2. If more than one volume is configured, press **Alt+N** to view the next array.
3. To manage the current array, press **Enter** when the **Manage Array** item is selected.

### 5.4.2 Activating an Array

An array can become inactive if, for example, it is removed from one controller or computer and moved to another one. The "Activate Array" option allows you to reactivate an inactive array that has been added to a system. This option is only available when the selected array is currently inactive.

Follow these steps to activate a selected array.

1. Select **Activate Array** on the Manage Array screen.
2. Press **Y** to proceed with the activation, or press **N** to abandon it. After a pause, the array will become active.

### 5.4.3 Deleting an Array

❖ **CAUTION:** Before deleting an array, be sure to back up all data on the array that you want to keep.

Follow these steps to delete a selected array:

1. Select **Delete Array** on the Manage Array screen.
  2. Press **Y** to delete the array, or press **N** to abandon the deletion. After a pause, the firmware deletes the array.
- ❖ **Note:** Once a volume has been deleted, it cannot be recovered. The master boot records of all disks are deleted.

### 5.4.4 Locating a Disk Drive, or Multiple Disk Drives in a Volume

You can use the SAS BIOS CU to locate and identify a specific physical disk drive by flashing the drive's LED. You can also use the SAS BIOS CU to flash the LEDs of all the disk drives in a RAID volume. There are several ways to do this:

- ▶ When you are creating an IS volume, and a disk drive is set to **Yes** as part of the volume, the LED on the disk drive is flashing. The LED is turned off when you

have finished creating the volume.

- ▶ You can locate individual disk drives from the SAS Topology screen. To do this, move the cursor to the name of the disk in the Device Identifier column and press **Enter**. The LED on the disk flashes until the next key is pressed.
- ▶ You can locate all the disk drives in a volume by selecting the volume on the RAID Properties screen. The LEDs flash on all disk drives in the volume.
- ❖ Note: The LEDs on the disk drives will flash as described above if the firmware is correctly configured and the drives or the disk enclosure supports disk location.

#### **5.4.5 Selecting a Boot Disk**

You can select a boot disk in the SAS Topology screen. This disk is then moved to scan ID 0 on the next boot, and remains at this position. This makes it easier to set BIOS boot device options and to keep the boot device constant during device additions and removals. There can be only one boot disk.

Follow these steps to select a boot disk:

1. In the SAS BIOS CU, select an adapter from the Adapter List.
  2. Select the **SAS Topology** option.

The current topology is displayed. If the selection of a boot device is supported, the bottom of the screen lists the Alt+B option. This is the key for toggling the boot device. If a device is currently configured as the boot device, the Device Info column on the SAS Topology screen will show the word "Boot."
  3. To select a boot disk, move the cursor to the disk and press **Alt+B**.
  4. To remove the boot designator, move the cursor down to the current boot disk and press **Alt+B**. This controller will no longer have a disk designated as boot.
  5. To change the boot disk, move the cursor to the new boot disk and press **Alt+B**. The boot designator will move to this disk.
- ❖ Note: The firmware must be configured correctly in order for the Alt+B feature to work.