

# X58M series

MS-7593 (v1.x) Mainboard



**msi**

## Copyright Notice

The material in this document is the intellectual property of **MICRO-STAR INTERNATIONAL**. We take every care in the preparation of this document, but no guarantee is given as to the correctness of its contents. Our products are under continual improvement and we reserve the right to make changes without notice.

## Trademarks

All trademarks are the properties of their respective owners.

- MSI® is registered trademark of Micro-Star Int'l Co.,Ltd.
- NVIDIA® is registered trademark of NVIDIA Corporation.
- ATI® is registered trademark of ATI Technologies, Inc.
- AMD® is registered trademarks of AMD Corporation.
- Intel® is registered trademarks of Intel Corporation.
- Windows® is registered trademarks of Microsoft Corporation.
- AMI® is registered trademark of Advanced Micro Devices, Inc.
- Award® is a registered trademark of Phoenix Technologies Ltd.
- Sound Blaster® is registered trademark of Creative Technology Ltd.
- Realtek® is registered trademark of Realtek Semiconductor Corporation.
- JMicon® is registered trademark of JMicon Technology Corporation.
- Netware® is a registered trademark of Novell, Inc.

## Revision History

Revision	Revision History	Date
V1.0	First release for PCB 1.X	March 2009

## Technical Support

If a problem arises with your system and no solution can be obtained from the user's manual, please contact your place of purchase or local distributor. Alternatively, please try the following help resources for further guidance.

- ☐ Visit the MSI website for FAQ, technical guide, BIOS updates, driver updates, and other information: <http://global.msi.com.tw/index.php?func=service>
- ☐ Contact our technical staff at: <http://ocss.msi.com.tw>

## Safety Instructions

- Always read the safety instructions carefully.
- Keep this User's Manual for future reference.
- Keep this equipment away from humidity.
- Lay this equipment on a reliable flat surface before setting it up.
- The openings on the enclosure are for air convection hence protects the equipment from overheating. **DO NOT COVER THE OPENINGS.**
- Make sure the voltage of the power source and adjust properly 110/220V before connecting the equipment to the power inlet.
- Place the power cord such a way that people can not step on it. Do not place anything over the power cord.
- Always Unplug the Power Cord before inserting any add-on card or module.
- All cautions and warnings on the equipment should be noted.
- Never pour any liquid into the opening that could damage or cause electrical shock.
- If any of the following situations arises, get the equipment checked by service personnel:
  - The power cord or plug is damaged.
  - Liquid has penetrated into the equipment.
  - The equipment has been exposed to moisture.
  - The equipment does not work well or you can not get it work according to User's Manual.
  - The equipment has dropped and damaged.
  - The equipment has obvious sign of breakage.

**DO NOT LEAVE THIS EQUIPMENT IN AN ENVIRONMENT UNCONDITIONED, STORAGE TEMPERATURE ABOVE 600 C (1400F), IT MAY DAMAGE THE EQUIPMENT.**

**CAUTION:** Danger of explosion if battery is incorrectly replaced.

Replace only with the same or equivalent type recommended by the manufacturer.

警告使用者:

這是甲類資訊產品，在居住的環境中使用時，可能會造成無線電干擾，在這種情況下，使用者會被要求採取某些適當的對策。



廢電池請回收

For better environmental protection, waste batteries should be collected separately for recycling special disposal.

## FCC-B Radio Frequency Interference Statement

This equipment has been tested and found to comply with the limits for a Class B digital device, pursuant to Part 15 of the FCC Rules. These limits are designed to provide reasonable protection against harmful interference in a residential installation. This equipment generates, uses and can radiate radio frequency energy and, if not installed and used in accordance with the instructions, may cause harmful interference to radio communications. However, there is no guarantee that interference will not occur in a particular installation. If this equipment does cause harmful interference to radio or television reception, which can be determined by turning the equipment off and on, the user is encouraged to try to correct the interference by one or more of the measures listed below.



- Reorient or relocate the receiving antenna.
- Increase the separation between the equipment and receiver.
- Connect the equipment into an outlet on a circuit different from that to which the receiver is connected.
- Consult the dealer or an experienced radio/television technician for help.

### Notice 1

The changes or modifications not expressly approved by the party responsible for compliance could void the user's authority to operate the equipment.

### Notice 2

Shielded interface cables and A.C. power cord, if any, must be used in order to comply with the emission limits.

OIR LA NOTICE D'INSTALLATION AVANT DE RACCORDER AU RESEAU.



This device complies with Part 15 of the FCC Rules. Operation is subject to the following two conditions:

- 1) this device may not cause harmful interference, and
- 2) this device must accept any interference received, including interference that may cause undesired operation.

## WEEE (Waste Electrical and Electronic Equipment) Statement

### ENGLISH

To protect the global environment and as an environmentalist, MSI must remind you that...



Under the European Union ("EU") Directive on Waste Electrical and Electronic Equipment, Directive 2002/96/EC, which takes effect on August 13, 2005, products of "electrical and electronic equipment" cannot be discarded as municipal waste anymore and manufacturers of covered electronic equipment will be obligated to take back such products at the end of their useful life. MSI will comply with the product take back requirements at the end of life of MSI-branded products that are sold into the EU. You can return these products to local collection points.

### DEUTSCH

Hinweis von MSI zur Erhaltung und Schutz unserer Umwelt

Gemäß der Richtlinie 2002/96/EG über Elektro- und Elektronik-Altgeräte dürfen Elektro- und Elektronik-Altgeräte nicht mehr als kommunale Abfälle entsorgt werden. MSI hat europaweit verschiedene Sammel- und Recyclingunternehmen beauftragt, die in die Europäische Union in Verkehr gebrachten Produkte, am Ende seines Lebenszyklus zurückzunehmen. Bitte entsorgen Sie dieses Produkt zum gegebenen Zeitpunkt ausschliesslich an einer lokalen Altgerätesammelstelle in Ihrer Nähe.

### FRANÇAIS

En tant qu'écologiste et afin de protéger l'environnement, MSI tient à rappeler ceci...

Au sujet de la directive européenne (EU) relative aux déchets des équipement électriques et électroniques, directive 2002/96/EC, prenant effet le 13 août 2005, que les produits électriques et électroniques ne peuvent être déposés dans les décharges ou tout simplement mis à la poubelle. Les fabricants de ces équipements seront obligés de récupérer certains produits en fin de vie. MSI prendra en compte cette exigence relative au retour des produits en fin de vie au sein de la communauté européenne. Par conséquent vous pouvez retourner localement ces matériels dans les points de collecte.

### РУССКИЙ

Компания MSI предпринимает активные действия по защите окружающей среды, поэтому напоминаем вам, что....

В соответствии с директивой Европейского Союза (ЕС) по предотвращению загрязнения окружающей среды использованным электрическим и электронным оборудованием (директива WEEE 2002/96/EC), вступающей в силу 13 августа 2005 года, изделия, относящиеся к электрическому и электронному оборудованию, не могут рассматриваться как бытовой мусор, поэтому производители вышеперечисленного электронного оборудования обязаны принимать его для переработки по окончании срока службы. MSI обязуется соблюдать требования по приему продукции, проданной под маркой MSI на территории ЕС, в переработку по окончании срока службы. Вы можете вернуть эти изделия в специализированные пункты приема.

## ESPAÑOL

MSI como empresa comprometida con la protección del medio ambiente, recomienda: Bajo la directiva 2002/96/EC de la Unión Europea en materia de desechos y/o equipos electrónicos, con fecha de rigor desde el 13 de agosto de 2005, los productos clasificados como "eléctricos y equipos electrónicos" no pueden ser depositados en los contenedores habituales de su municipio, los fabricantes de equipos electrónicos, están obligados a hacerse cargo de dichos productos al término de su período de vida. MSI estará comprometido con los términos de recogida de sus productos vendidos en la Unión Europea al final de su período de vida. Usted debe depositar estos productos en el punto limpio establecido por el ayuntamiento de su localidad o entregar a una empresa autorizada para la recogida de estos residuos.

## NEDERLANDS

Om het milieu te beschermen, wil MSI u eraan herinneren dat...

De richtlijn van de Europese Unie (EU) met betrekking tot Vervuiling van Electriche en Electronische producten (2002/96/EC), die op 13 Augustus 2005 in zal gaan kunnen niet meer beschouwd worden als vervuiling. Fabrikanten van dit soort producten worden verplicht om producten retour te nemen aan het eind van hun levenscyclus. MSI zal overeenkomstig de richtlijn handelen voor de producten die de merknaam MSI dragen en verkocht zijn in de EU. Deze goederen kunnen geretourneerd worden op lokale inzamelingspunten.

## SRPSKI

Da bi zaštitili prirodnu sredinu, i kao preduzeće koje vodi računa o okolini i prirodnoj sredini, MSI mora da vas podesti da...

Po Direktivi Evropske unije ("EU") o odbačenoj eelektronskoj i električnoj opremi, Direktiva 2002/96/EC, koja stupa na snagu od 13. Avgusta 2005, proizvodi koji spadaju pod "elektronsku i električnu opremu" ne mogu više biti odbačeni kao običan otpad i proizvođači ove opreme biće prinuđeni da uzmu natrag ove proizvode na kraju njihovog uobičajenog veka trajanja. MSI će poštovati zahtev o preuzimanju ovakvih proizvoda kojima je istekao vek trajanja, koji imaju MSI oznaku i koji su prodati u EU. Ove proizvode možete vratiti na lokalnim mestima za prikupljanje.

## POLSKI

Aby chronić nasze środowisko naturalne oraz jako firma dbająca o ekologię, MSI przypomina, że...

Zgodnie z Dyrektywą Unii Europejskiej ("UE") dotyczącą odpadów produktów elektrycznych i elektronicznych (Dyrektywa 2002/96/EC), która wchodzi w życie 13 sierpnia 2005, tzw. "produkty oraz wyposażenie elektryczne i elektroniczne" nie mogą być traktowane jako śmieci komunalne, tak więc producenci tych produktów będą zobowiązani do odbierania ich w momencie gdy produkt jest wycofywany z użycia. MSI wypełni wymagania UE, przyjmując produkty (sprzedawane na terenie Unii Europejskiej) wycofywane z użycia. Produkty MSI będzie można zwracać w wyznaczonych punktach zbiorczych.

## TÜRKÇE

Çevreci özelliğiyle bilinen MSI dünyada çevreyi korumak için hatırlatır:

Avrupa Birliği (AB) Kararnamesi Elektrik ve Elektronik Malzeme Atığı, 2002/96/EC Kararnamesi altında 13 Ağustos 2005 tarihinden itibaren geçerli olmak üzere, elektrikli ve elektronik malzemeler diğer atıklar gibi çöpe atılmayacak ve bu elektronik cihazların üreticileri, cihazların kullanım süreleri bittikten sonra ürünleri geri toplamakla yükümlü olacaktır. Avrupa Birliği'ne satılan MSI markalı ürünlerin kullanım süreleri bittiğinde MSI ürünlerin geri alınması isteği ile işbirliği içerisinde olacaktır. Ürünlerinizi yerel toplama noktalarına bırakabilirsiniz.

## ČESKY

Záleží nám na ochraně životního prostředí - společnost MSI upozorňuje...

Podle směrnice Evropské unie ("EU") o likvidaci elektrických a elektronických výrobků 2002/96/EC platné od 13. srpna 2005 je zakázáno likvidovat "elektrické a elektronické výrobky" v běžném komunálním odpadu a výrobci elektrických výrobků, na které se tato směrnice vztahuje, budou povinni odebírat takové výrobky zpět po skončení jejich životnosti. Společnost MSI splní požadavky na odebírání výrobků značky MSI, prodávaných v zemích EU, po skončení jejich životnosti. Tyto výrobky můžete odevzdat v místních sběrnách.

## MAGYAR

Annak érdekében, hogy környezetünket megvédjük, illetve környezetvédőként fellépve az MSI emlékezteti Önt, hogy ...

Az Európai Unió („EU”) 2005. augusztus 13-án hatályba lépő, az elektromos és elektronikus berendezések hulladékairól szóló 2002/96/EK irányelve szerint az elektromos és elektronikus berendezések többé nem kezelhetőek lakossági hulladékként, és az ilyen elektronikus berendezések gyártói köteleessé válnak az ilyen termékek visszavételére azok hasznos élettartama végén. Az MSI betartja a termékvisszavétellel kapcsolatos követelményeket az MSI márkánév alatt az EU-n belül értékesített termékek esetében, azok élettartamának végén. Az ilyen termékeket a legközelebbi gyűjtőhelyre viheti.

## ITALIANO

Per proteggere l'ambiente, MSI, da sempre amica della natura, ti ricorda che....

In base alla Direttiva dell'Unione Europea (EU) sullo Smaltimento dei Materiali Elettrici ed Elettronici, Direttiva 2002/96/EC in vigore dal 13 Agosto 2005, prodotti appartenenti alla categoria dei Materiali Elettrici ed Elettronici non possono più essere eliminati come rifiuti municipali: i produttori di detti materiali saranno obbligati a ritirare ogni prodotto alla fine del suo ciclo di vita. MSI si adegnerà a tale Direttiva ritirando tutti i prodotti marchiati MSI che sono stati venduti all'interno dell'Unione Europea alla fine del loro ciclo di vita. È possibile portare i prodotti nel più vicino punto di raccolta

## CONTENTS

Copyright Notice.....	ii
Trademarks .....	ii
Revision History.....	ii
Technical Support.....	ii
Safety Instructions.....	iii
FCC-B Radio Frequency Interference Statement.....	iv
WEEE (Waste Electrical and Electronic Equipment) Statement .....	v
<b>Chapter 1 Getting Started.....</b>	<b>1-1</b>
Mainboard Specifications .....	1-2
Mainboard Layout .....	1-4
Packing Checklist.....	1-5
<b>Chapter 2 Hardware Setup.....</b>	<b>2-1</b>
Quick Components Guide .....	2-2
CPU (Central Processing Unit) .....	2-3
Memory .....	2-7
Power Supply.....	2-11
Back Panel.....	2-12
Connectors.....	2-14
Jumpers .....	2-21
Switch.....	2-22
Button.....	2-23
Slots .....	2-24
LED Status Indicators .....	2-30
<b>Chapter 3 BIOS Setup.....</b>	<b>3-1</b>
Entering Setup .....	3-2
The Main Menu .....	3-4
Standard CMOS Features.....	3-6
Advanced BIOS Features .....	3-8
Integrated Peripherals.....	3-11
Power Management Setup.....	3-13
H/W Monitor .....	3-15



---

Green Power .....	3-16
BIOS Setting Password.....	3-17
Cell Menu .....	3-18
Overclocking Profile .....	3-24
M-Flash .....	3-25
Load Fail-Safe/ Optimized Defaults .....	3-28
<b>Appendix A Realtek Audio.....</b>	<b>A-1</b>
Installing the Realtek HD Audio Driver.....	A-2
Software Configuration.....	A-4
Hardware Setup .....	A-19
<b>Appendix B Overclocking Center.....</b>	<b>B-1</b>
Activating Overclocking Center .....	B-2
System Info .....	B-3
DOT.....	B-5



# Chapter 1

## Getting Started

Thank you for choosing the **X58M** Series (MS-7593 v1.X) Micro ATX mainboard. The **X58M** Series mainboards are based on Intel® **X58** & **ICH10R/ ICH10** (optional) chipsets for optimal system efficiency. Designed to fit the advanced Intel® **i7 LGA1366** processor, the **X58M** Series deliver a high performance and professional desktop platform solution.

# MAINBOARD SPECIFICATIONS

---

### Processor Support

- Intel® i7 processor in the LGA1366 package  
(For the latest information about CPU, please visit <http://global.msi.com.tw/index.php?func=cpuform2>)

### QPI

- Up to 6.4 GT/s

### Chipset

- North Bridge: Intel® X58 chipset
- South Bridge: Intel® ICH10R/ ICH10 (optional) chipset

### Memory Support

- 6 DDR3 DIMMs support DDR3 1333/ 1066/ 800 DRAM speed (24GB Max)
- Supports 1Gb/ 2Gb/ 4Gb DRAM size
- Supports x8/ x16 data lines per DRAM
- Supports Triple-Channel mode  
(For more information on compatible components, please visit <http://global.msi.com.tw/index.php?func=testreport>)

### LAN

- Supports 10/100/1000 LAN by Realtek® RTL8111C

### IEEE 1394 (optional)

- Chip integrated by VIA® VT6315N
- Transfer rate is up to 400Mbps

### Audio

- Chip integrated by Realtek® ALC888S/ ALC889
- Flexible 8-channel audio with jack sensing
- Compliant with Azalia 1.0 Spec

### IDE

- 1 IDE port by JMicron® JMB363
- Supports Ultra DMA 66/100/133 mode
- Supports PIO, Bus Master operation mode

### SATA

- 6 SATAII (SATA1~6) ports by Intel® ICH10R/ ICH10 (optional)
- 1 SATAII (SATA7) port by JMicron® JMB363
- 1 E-SATA port (back panel) by JMicron® JMB363
- Supports storage and data transfers at up to 3 Gb/s

## RAID

- SATA1~6 support Intel® Matrix Storage Technology (AHCI/ RAID 0/ 1/ 5/ 10) by ICH10R

## Floppy

- 1 floppy port
- Supports 1 FDD with 360 KB, 720 KB, 1.2 MB, 1.44 MB and 2.88 MB

## Connectors

- Back panel
  - 1 PS/2 keyboard port
  - 1 PS/2 mouse port
  - 6 USB 2.0 ports
  - 1 E-SATA port
  - 1 IEEE 1394 port (optional)
  - 1 LAN port
  - 6 flexible audio ports
- On-Board
  - 3 USB 2.0 connectors
  - 1 IEEE 1394 connector (optional)
  - 1 Chassis Intrusion connector
  - 1 Serial connector
  - 1 CD-In connector
  - 1 Front Panel Audio connector
  - 1 TPM Module connector (optional)
  - 1 Hardware Overclock Base clock switch
  - 1 Power button
  - 1 S/PDIF-Out connector

## Slots

- 2 PCI Express 2.0 x16 slots
- 1 PCI Express 2.0 x4 slot
- 1 PCI slot, support 3.3V/ 5V PCI bus Interface

## Form Factor

- Micro-ATX (24.5cm X 24.5 cm)

## Mounting

- 8 mounting holes

# MAINBOARD LAYOUT

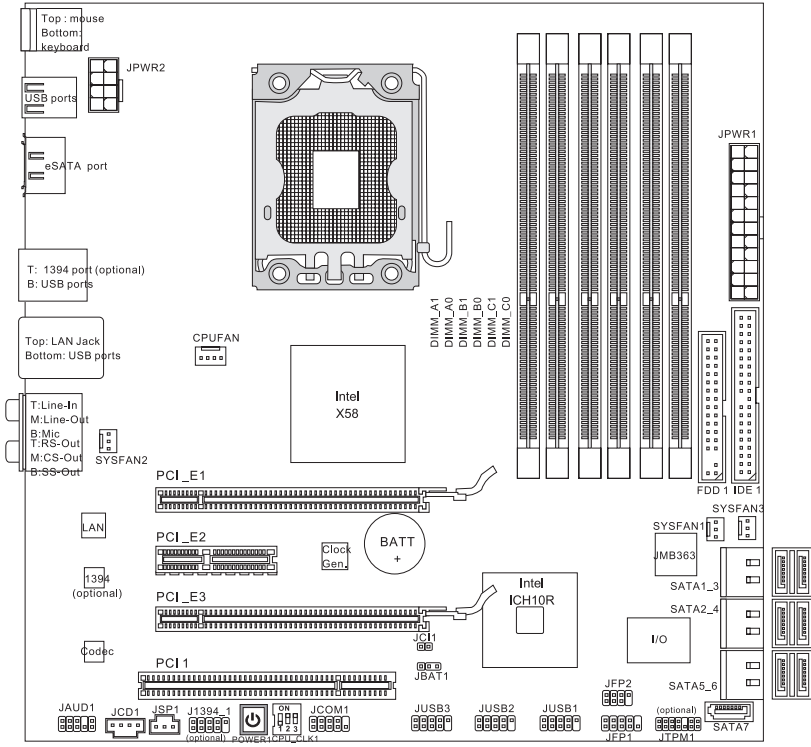

**X58M Series (MS-7593 v1.X) Mainboard**

## PACKING CHECKLIST



MSI mainboard



MSI Driver/Utility DVD



SATA Cable (Optional)



Power Cable



USB Bracket (Optional)

Standard Cable for  
IDE Devices

Back IO Shield



User's Guide

\* The pictures are for reference only and may vary from the packing contents of the product you purchased.





# Chapter 2

## Hardware Setup

This chapter provides you with the information about hardware setup procedures. While doing the installation, be careful in holding the components and follow the installation procedures. For some components, if you install in the wrong orientation, the components will not work properly.

Use a grounded wrist strap before handling computer components. Static electricity may damage the components.

## QUICK COMPONENTS GUIDE

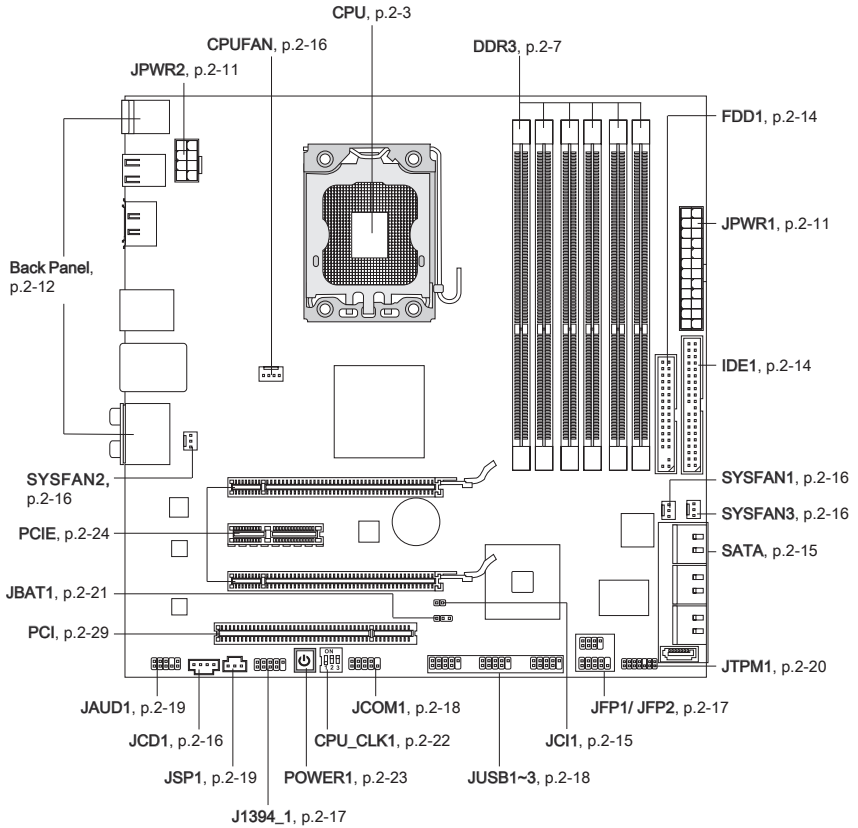

## CPU (CENTRAL PROCESSING UNIT)

When you are installing the CPU, make sure to install the cooler to prevent overheating. If you do not have the CPU cooler, consult your dealer before turning on the computer. For the latest information about CPU, please visit <http://global.msi.com.tw/index.php?func=cpuform2>

### **Important**

#### **Overheating**

*Overheating will seriously damage the CPU and system. Always make sure the cooling fan can work properly to protect the CPU from overheating. Make sure that you apply an even layer of thermal paste (or thermal tape) between the CPU and the heatsink to enhance heat dissipation.*

#### **Replacing the CPU**

*While replacing the CPU, always turn off the ATX power supply or unplug the power supply's power cord from the grounded outlet first to ensure the safety of CPU.*

#### **Overclocking**

*This mainboard is designed to support overclocking. However, please make sure your components are able to tolerate such abnormal setting, while doing overclocking. Any attempt to operate beyond product specifications is not recommended. We do not guarantee the damages or risks caused by inadequate operation or beyond product specifications.*

### Introduction to LGA 1366 CPU

The pin-pad side of LGA 1366 CPU.

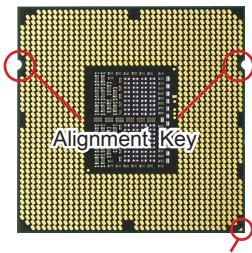

Yellow triangle is the Pin 1 indicator

The surface of LGA 1366 CPU. Remember to apply some thermal paste on it for better heat dispersion.

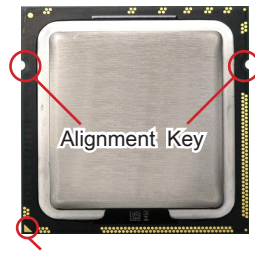

Yellow triangle is the Pin 1 indicator

### CPU & Cooler Installation

When you are installing the CPU, make sure the CPU has a cooler attached on the top to prevent overheating. Meanwhile, do not forget to apply some thermal paste on CPU before installing the heat sink/cooler fan for better heat dispersion.

Follow the steps below to install the CPU & cooler correctly. Wrong installation will cause the damage of your CPU & mainboard.

1. Open the load level.
2. Lift the load lever up and open the load plate.

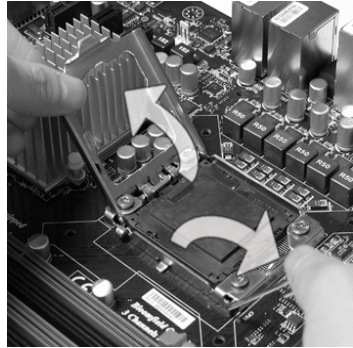
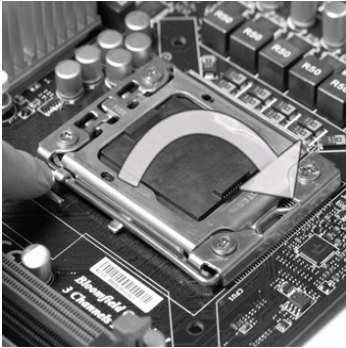

3. The CPU socket has a plastic cap on it to protect the contact from damage. Before you install CPU, always cover it to protect the socket pin. Remove the cap from the lever hinge side (as the arrow shows).
4. After confirming the CPU direction for correct mating, put down the CPU in the socket housing frame. Be sure to grasp on the edge of the CPU base. Note that the alignment keys are matched.

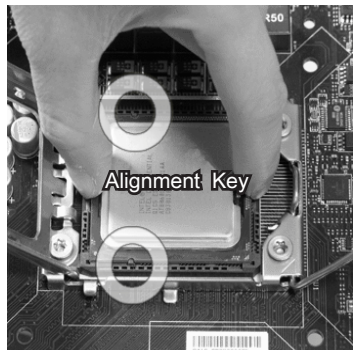
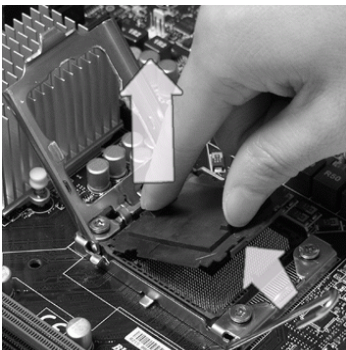

5. Visually inspect if the CPU is seated well into the socket. If not, take out the CPU with pure vertical motion and reinstall.

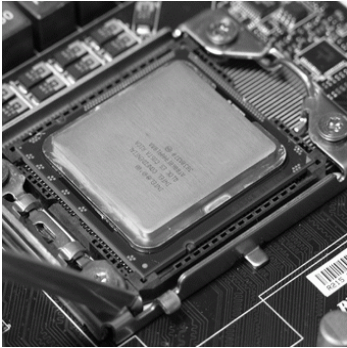

6. Cover the load plate onto the package.

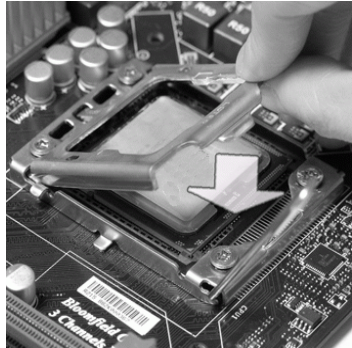

7. Press down the load lever lightly onto the load plate, and then secure the lever with the hook under retention tab.

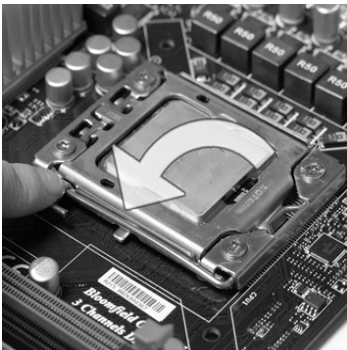

8. Make sure the four hooks are in proper position before you install the cooler.



### **Important**

- Confirm if your CPU cooler is firmly installed before turning on your system.
- Do not touch the CPU socket pins to avoid damaging.

9. Align the holes on the mainboard with the heatsink. Push down the cooler until its four clips get wedged into the holes of the mainboard.

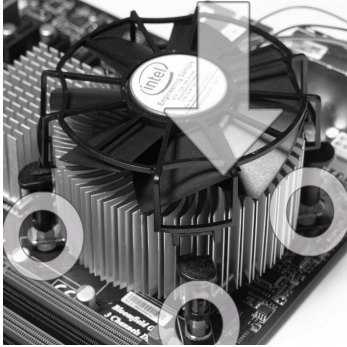

10. Press the four hooks down to fasten the cooler.

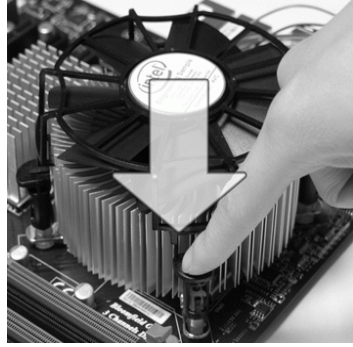

11. Turn over the mainboard to confirm that the clip-ends are correctly inserted.

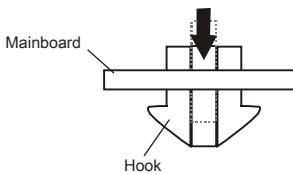

12. Finally, attach the CPU Fan cable to the CPU fan connector on the mainboard.

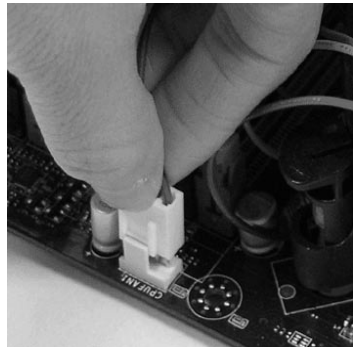

### **Important**

- Read the CPU status in BIOS.
- Whenever CPU is not installed, always protect your CPU socket pin with the plastic cap covered (shown in Figure 1) to avoid damaging.
- Mainboard photos shown in this section are for demonstration of the CPU/ cooler installation only. The appearance of your mainboard may vary depending on the model you purchase.
- Please refer to the documentation in the CPU fan package for more details about the CPU fan installation.

## MEMORY

These DIMM slots are used for installing memory modules. For more information on compatible components, please visit <http://global.msi.com.tw/index.php?func=testreport>

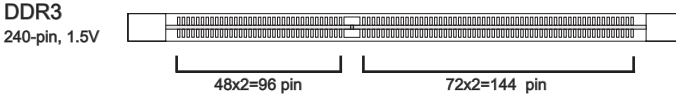

### Memory Population Rule

Please refer to the following illustrations for memory population rules.

#### Single-Channel mode

When you have only one memory module, please always insert it into the DIMM\_A0 first (as way 1 shown in below).

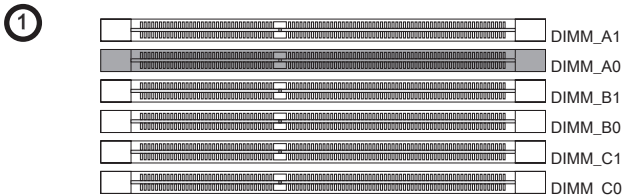

#### Dual-Channel mode

In Dual-Channel mode, the memory modules can transmit and receive data with two data bus lines simultaneously. Enabling Dual-Channel mode can enhance the system performance. When you have two memory modules, please always insert them into the DIMM\_A0 & DIMM\_B0 (as way 2 shown in below).

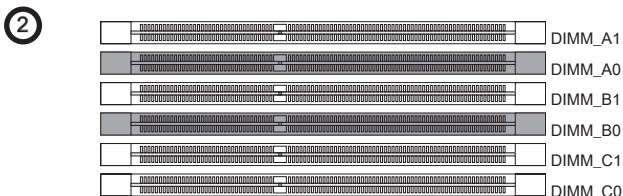

### Triple-Channel mode

In Triple-Channel mode, the memory modules can transmit and receive data with three data bus lines simultaneously. Enabling Triple-Channel mode can enhance the best system performance. When you have three or more memory modules, please always insert them as the way 3/ 4/ 5/ 6 (shown in below) to get the best system performance.

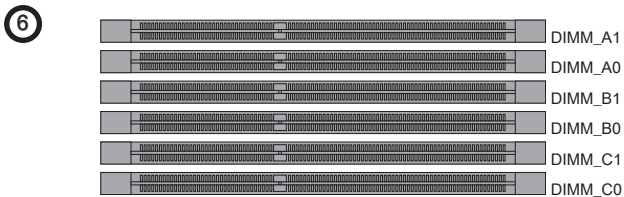
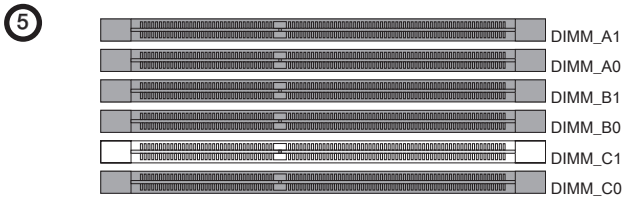
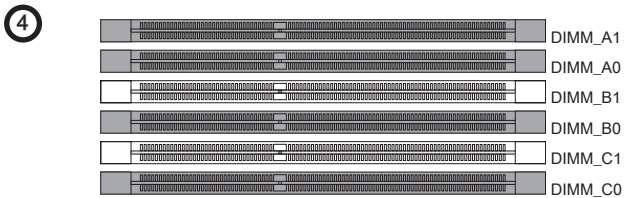
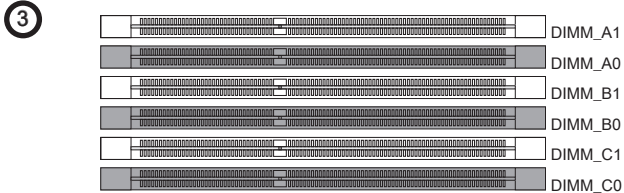



### **Important**

- *DDR3 memory modules are not interchangeable with DDR2 and the DDR3 standard DDR3 memory modules are not interchangeable with DDR2 and the DDR3 standard is not backwards compatible. You should always install DDR3 memory modules in the DDR3 DIMM slots.*
- *In Triple channel/ Dual channel mode, make sure that you install memory modules of the same type and density in different channel DIMM slots. If the speeds of installed memory modules are different (ex. 1066 & 1333), the system will detect and operate the lower speed (1066) with all installed memory modules.*
- *Please always install the same type and density memory modules in DIMM slots to avoid the damage of memory.*
- *To enable successful system boot-up, always insert the memory modules into the DIMM\_A0 first.*
- *Due to the chipset resource deployment, the system density will only be detected up to 23+GB (not full 24GB) when each DIMM is installed with a 4GB memory module.*
- *When you install incorrect memory module (the SA2-pin of the memory module connects to Ground) in the DIMM\_C0/C1, the LED beside DIMM\_C0 will light red color to remind you. The position of the LED is shown as below. Double confirm with your memory module vender for the third channelsupports.*

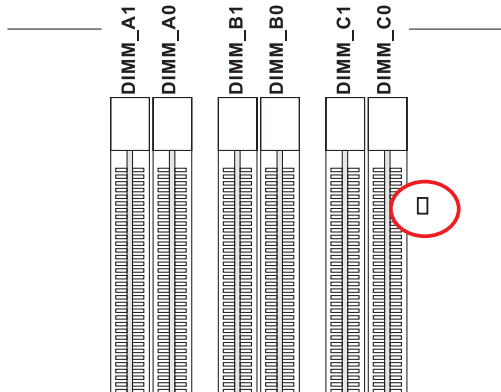

## Installing Memory Modules

1. The memory module has only one notch on the center and will only fit in the right orientation.
2. Insert the memory module vertically into the DIMM slot. Then push it in until the golden finger on the memory module is deeply inserted in the DIMM slot. The plastic clip at each side of the DIMM slot will automatically close when the memory module is properly seated.
3. Manually check if the memory module has been locked in place by the DIMM slot clips at the sides.

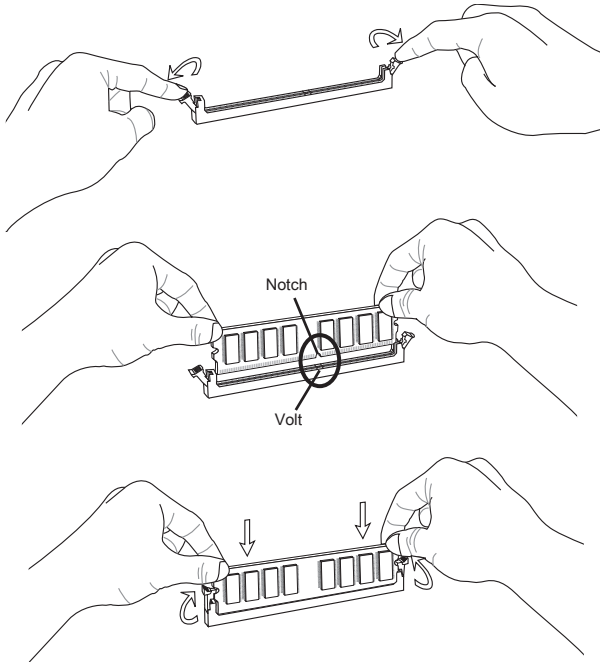

### **Important**

*You can barely see the golden finger if the memory module is properly inserted in the DIMM slot.*

## POWER SUPPLY

### ATX 24-pin Power Connector: JPWR1

This connector allows you to connect an ATX 24-pin power supply. To connect the ATX 24-pin power supply, make sure the plug of the power supply is inserted in the proper orientation and the pins are aligned. Then push down the power supply firmly into the connector.

You may use the 20-pin ATX power supply as you like. If you'd like to use the 20-pin ATX power supply, please plug your power supply along with pin 1 & pin 13.

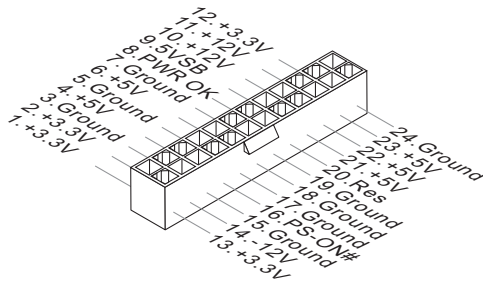

### ATX 8-pin Power Connector: JPWR2

This connector is used to provide 12V power output to the CPU.

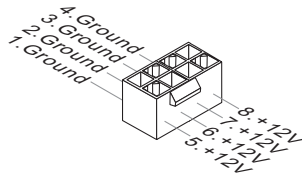

### **Important**

- Make sure that all the connectors are connected to proper ATX power supplies to ensure stable operation of the mainboard.
- Power supply of 400 watts (and above) is highly recommended for system stability.
- ATX 12V power connection should be greater than 18A.

## BACK PANEL

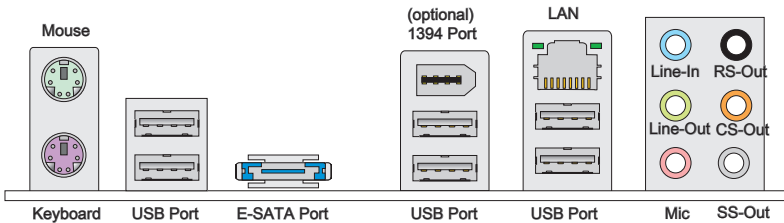

### ► Mouse/Keyboard

The standard PS/2® mouse/keyboard DIN connector is for a PS/2® mouse/keyboard. VGA Port

### ► USB Port

The USB (Universal Serial Bus) port is for attaching USB devices such as keyboard, mouse, or other USB-compatible devices.

### ► E-SATA Port

The E-SATA (External-SATA) port is for attaching the E-SATA hard drive.

### ► 1394 Port (optional)

The IEEE1394 port on the back panel provides connection to IEEE1394 devices.

### ► LAN

The standard RJ-45 LAN jack is for connection to the Local Area Network (LAN). You can connect a network cable to it.

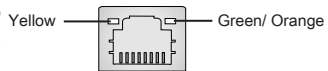

LED	Color	LED State	Condition
Left	Yellow	Off	LAN link is established.
		On (Steady state)	LAN link is established.
		On (brighter & pulsing)	The computer is communicating with another computer on the LAN.
Right	Green	Off	10 Mbits/sec data rate is selected.
		On	100 Mbits/sec data rate is selected.
	Orange	On	1000 Mbits/sec data rate is selected.

**► Audio Ports**

These audio connectors are used for audio devices. It is easy to differentiate between audio effects according to the color of audio jacks.

- Line-In (Blue) - Line In, is used for external CD player, tape-player or other audio devices.
- Line-Out (Green) - Line Out, is a connector for speakers or headphones.
- Mic (Pink) - Mic, is a connector for microphones.
- RS-Out (Black) - Rear-Surround Out in 4/ 5.1/ 7.1 channel mode.
- CS-Out (Orange) - Center/ Subwoofer Out in 5.1/ 7.1 channel mode.
- SS-Out (Gray) - Side-Surround Out 7.1 channel mode.

## CONNECTORS

### Floppy Disk Drive Connector: FDD1

This connector supports 360 KB, 720 KB, 1.2 MB, 1.44 MB or 2.88 MB floppy disk drive.

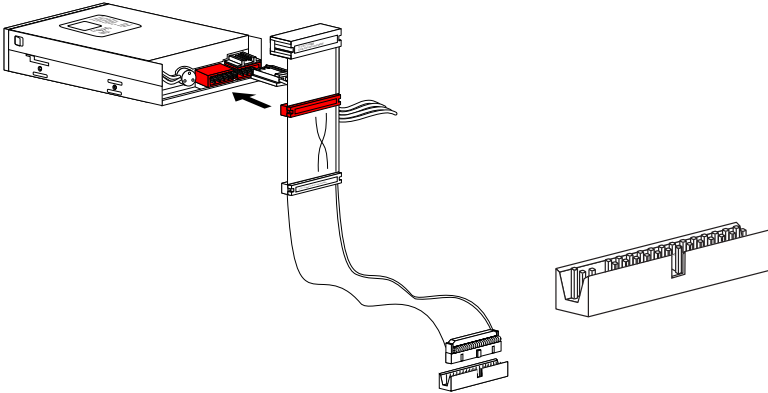

### IDE Connector: IDE1

This connector supports IDE hard disk drives, optical disk drives and other IDE devices.

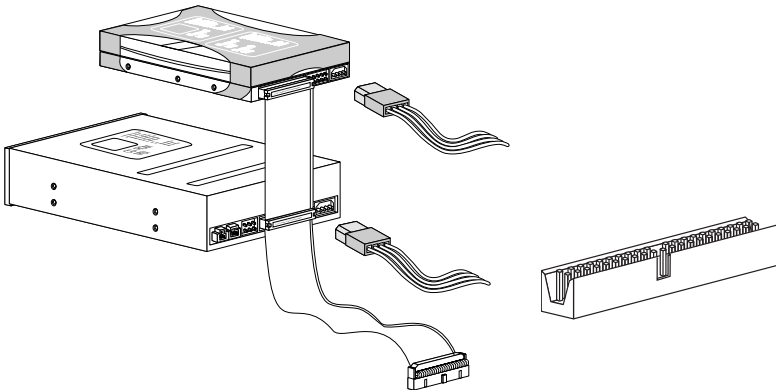

### **Important**

If you install two IDE devices on the same cable, you must configure the drives separately to master / slave mode by setting jumpers. Refer to IDE device's documentation supplied by the vendors for jumper setting instructions.

## Serial ATA Connector: SATA1~7

This connector is a high-speed Serial ATA interface port. Each connector can connect to one Serial ATA device.

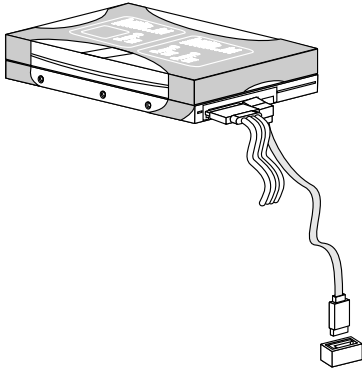

SATA1~6 supported by ICH10R

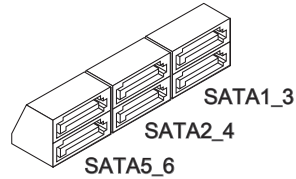

SATA7 supported by JMB363



### **Important**

*Please do not fold the Serial ATA cable into 90-degree angle. Otherwise, data loss may occur during transmission.*

## Chassis Intrusion Connector: JCI1

This connector connects to the chassis intrusion switch cable. If the chassis is opened, the chassis intrusion mechanism will be activated. The system will record this status and show a warning message on the screen. To clear the warning, you must enter the BIOS utility and clear the record.

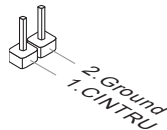

### Fan Power Connectors: CPUFAN1, SYSFAN1, SYSFAN2, SYSFAN3

The fan power connectors support system cooling fan with +12V. When connecting the wire to the connectors, always note that the red wire is the positive and should be connected to the +12V; the black wire is Ground and should be connected to GND. If the mainboard has a System Hardware Monitor chipset on-board, you must use a specially designed fan with speed sensor to take advantage of the CPU fan control.

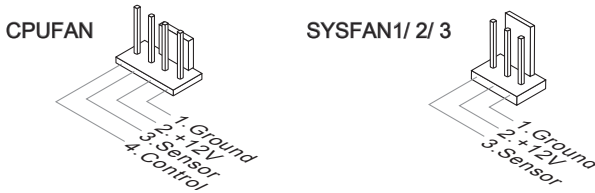

### **Important**

- Please refer to the recommended CPU fans at processor's official website or consult the vendors for proper CPU cooling fan.
- CPUFAN & SYSFAN1 support Smart fan control. You can install **Overclocking Center** utility that will automatically control the CPUFAN & SYSFAN1 speeds according to the actual CPUFAN & SYSFAN1 temperatures.
- Fan cooler set with 3 or 4 pins power connector are both available for CPUFAN.

### CD-In Connector: JCD1

This connector is provided for external audio input.

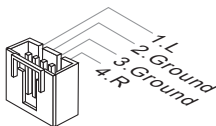



## Front Panel Connectors: JFP1, JFP2

These connectors are for electrical connection to the front panel switches and LEDs. The JFP1 is compliant with Intel® Front Panel I/O Connectivity Design Guide.

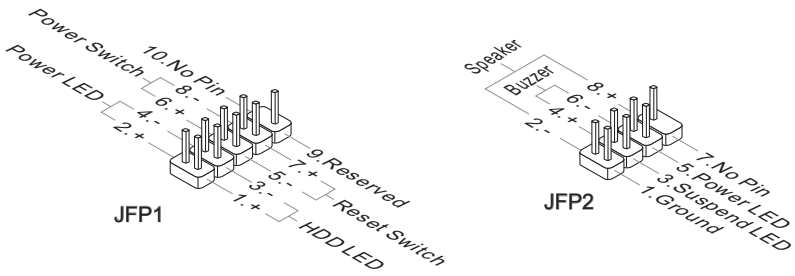

## IEEE1394 Connector: J1394\_1 (Optional)

This connector allows you to connect the IEEE1394 device via an optional IEEE1394 bracket.

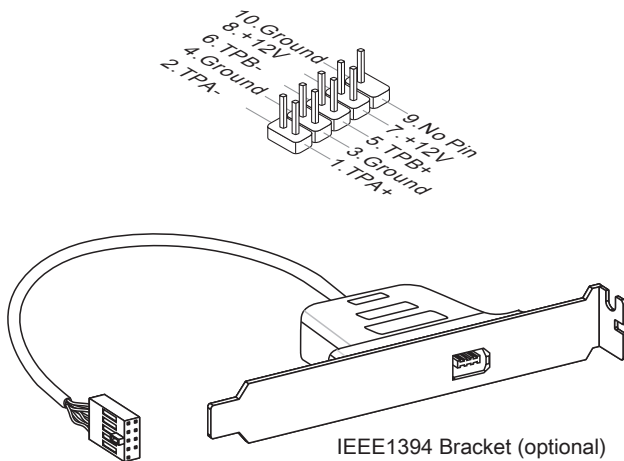

### Front USB Connector: JUSB1 / JUSB2 / JUSB3

This connector, compliant with Intel® I/O Connectivity Design Guide, is ideal for connecting high-speed USB interface peripherals such as USB HDD, digital cameras, MP3 players, printers, modems and the like.

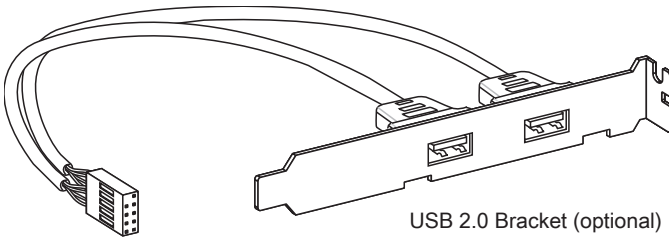
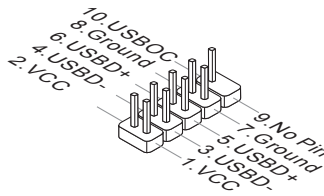

USB 2.0 Bracket (optional)

### **Important**

Note that the pins of VCC and GND must be connected correctly to avoid possible damage.

### Serial Connector: JCOM1

This connector is a 16550A high speed communication port that sends/ receives 16 bytes FIFOs. You can attach a serial device.

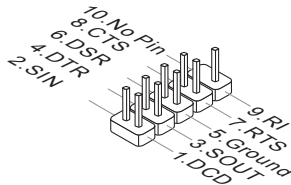

## S/PDIF-Out Connector: JSP1

This connector is used to connect S/PDIF (Sony & Philips Digital Interconnect Format) interface for digital audio transmission.

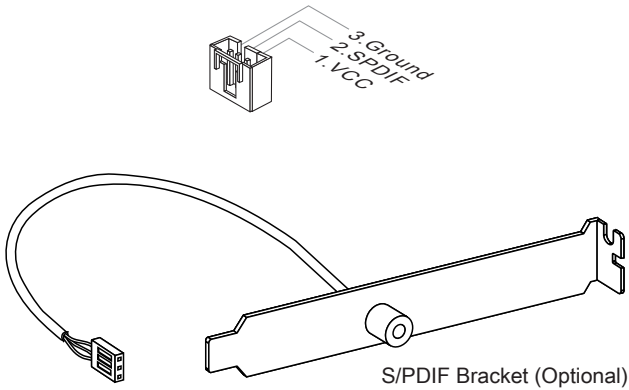

## Front Panel Audio Connector: JAUD1

This connector allows you to connect the front panel audio and is compliant with Intel® Front Panel I/O Connectivity Design Guide.

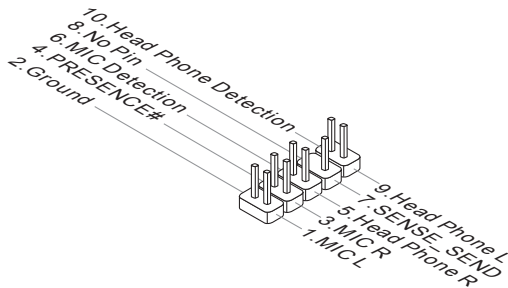

### TPM Module connector: JTPM1 (optional)

This connector connects to a TPM (Trusted Platform Module) module (optional). Please refer to the TPM security platform manual for more details and usages.

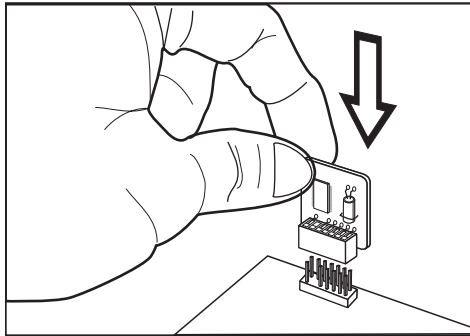
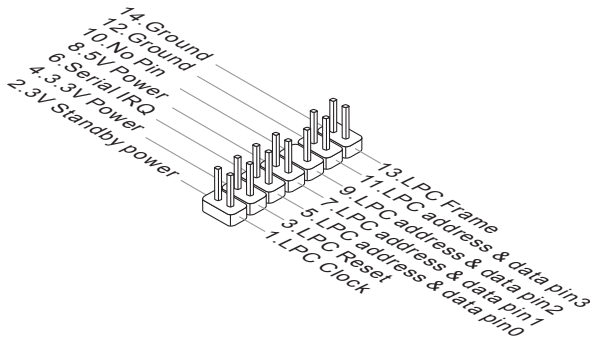

## JUMPERS

---

### Clear CMOS Jumper: JBAT1

There is a CMOS RAM onboard that has a power supply from an external battery to keep the data of system configuration. With the CMOS RAM, the system can automatically boot OS every time it is turned on. If you want to clear the system configuration, set the jumper to clear data.



JBAT1



Keep Data



Clear Data

### **Important**

*You can clear CMOS by shorting 2-3 pin while the system is off. Then return to 1-2 pin position. Avoid clearing the CMOS while the system is on; it will damage the mainboard.*

### SWITCH

This mainboard provides the following switch for you to set the computer's function. This section will explain how to change your mainboard's function through the use of switch.

#### Hardware Overclock Base clock Switch: CPU\_CLK1

You can overclock the Base clock to increase the processor frequency by changing this switch. Follow the instructions below to set the base clock.



133 MHz  
(default)



166 MHz



200 MHz

#### **Important**

- Make sure that you power off the system before changing the switch.
- This overclocking behavior depends on the system's configuration (memory capability, thermal solution...etc), and it is not guaranteed.
- You can also overclock by setting BIOS. BIOS overclocking may also cause crash during boot and then please reboot the system 3 times to restore default BIOS settings. For more details, please refer to the BIOS chapter.
- When overclocking cause instability or crash during boot, the following warning message will display during POST (as picture below). And then, please re-set the switch to default.

Warning!!! OC switch overclocking had failed.  
Please shutdown and adjust oc switch to lower frequency.  
Try again!

## BUTTON

---

The mainboard provides the following button for you to set the computer's function. This section will explain how to change your mainboard's function through the use of button.

### Power Button: POWER1

This power button is used to turn-on or turn-off the system. Press the button to turn-on or turn-off the system.



### **Important**

*This button will light whsn system is power-on.*

## SLOTS

### PCI E (Peripheral Component Interconnect Express) Slot

The PCI Express slot supports the PCI Express interface expansion card.

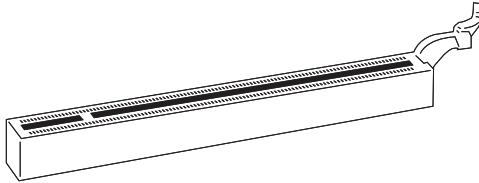

PCI Express 2.0x16 Slot

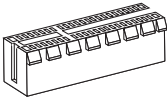

PCI Express 2.0x4 Slot

### **Important**

*When adding or removing expansion cards, make sure that you unplug the power supply first. Meanwhile, read the documentation for the expansion card to configure any necessary hardware or software settings for the expansion card, such as jumpers, switches or BIOS configuration.*



## ATI CrossFireX™ (Multi-GPU) Technology

ATI CrossFireX™ is the ultimate multi-GPU performance gaming platform. Enabling game-dominating power, ATI CrossFireX™ technology enables two or more discrete graphics processors to work together to improve system performance. ATI CrossFireX™ technology allows you to expand your system's graphics capabilities. It allows you the ability to scale your system's graphics horsepower as you need it, supporting two ATI Radeon™ HD graphics cards, making this the most scalable gaming platform ever. The mainboard can auto detect the CrossFireX™ mode by software, therefore you don't have to enable the CrossFireX™ in BIOS by yourself. The following details the CrossFireX™ installation.

1. Install one ATI Radeon™ HD graphics card in first PCIE x16 slot , then install one ATI Radeon™ HD graphics card in second PCIE x16 slot.
2. With two cards installed, an CrossFireX™ Video Link cable is required to connect the golden fingers on the top of these two graphics cards (refer to the picture below). Please note that although you have installed two graphics cards, only the video outputs on the graphics card installed in first PCIE x16 slot will work. Hence, you only need to connect a monitor to this graphics card.

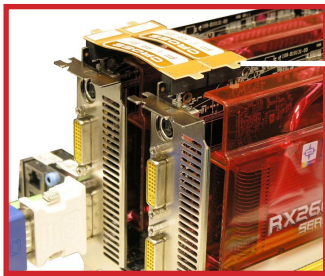

CrossFireX™ Video Link cable

### **Important**

- Mainboard photos shown in this section are for demonstration only. The appearance of your rwk may vary depending on the model you purchase.
- If you intend to install TWO graphics cards for CrossFireX™ mode, make sure that these two graphics cards are of the same brand.
- Make sure that you connect an adequate power supply to the power connector on the graphics card to ensure stable operation of the graphics card.
- Only Windows®XP with Service Pack 2 (SP2)& Windows®XP Professional x64 Edition & Windows®Vista support the CrossFireX™ function.

- When all of the hardware and software has been properly set up and installed, reboot the system. After entering the O.S., click the “Catalyst™ Control Center” icon on the desktop. There is a setting in the Catalyst™ Control Center that needs to be enabled for CrossFireX™ to operate. The following aspect appears in Catalyst™ Control Center:

Select the Advanced View from the view drop menu.



### **Important**

A CrossFireX™ system has four possible display modes:

- SuperTiling
- Scissor Mode
- Alternate Frame Rendering
- Super Anti-aliasing.

for more details, please consult the graphics card manual from the manufacturer.

## NVIDIA® SLI Technology (Optional)

NVIDIA® SLI (Scalable Link Interface) technology allows two GPUs to run in tandem within a system to achieve up to twice the performance of a single graphics card. To utilize this technology, the two GPU cards must be connected by an SLI Video Link card.



SLI Video Link Card

If you intend to use the SLI mode for better graphics performance, please refer to the following instructions.

1. Install two graphics cards on PCI Express x16 slots. With two cards installed, an SLI Video Link Card is required to connect the golden fingers on the top of these two graphics cards (refer to the picture below). Please note that although you have installed two graphics cards, only the video outputs on the first card will work. Hence, you only need to connect a monitor to the first PCI Express card.

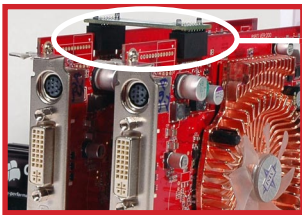

SLI Video Link Card

### **Important**

- *The photos shown in this section are for demonstration only. The appearance of your mainboard may vary depending on the model you purchase.*
- *If you intend to install TWO x16 graphics cards, make sure that these two graphics cards are of the same brand and specifications.*
- *Make sure that you connect an adequate power supply to the power connector on the graphics card to ensure stable operation of the graphics card.*

- After the hardware installation is completed, restart the system and install the NV SLI driver/utility. A configuration panel will be provided for Multi-GPU control. Check the Enable multi-GPU box to enable the SLI function for the onboard graphics cards (concerning the details of multi-GPU settings, please refer to your graphics card manual).

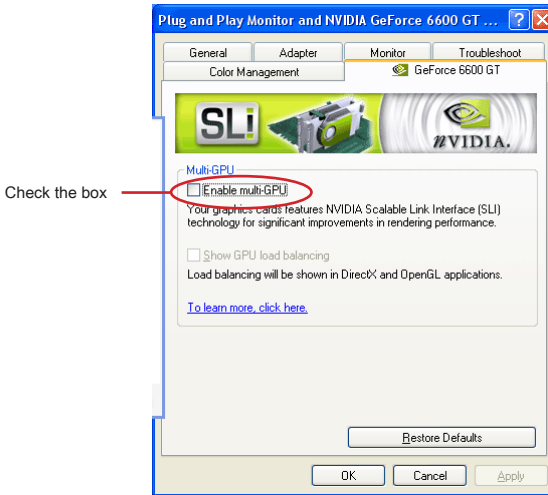

- Restart your system and a pop-up message will show in the system tray confirming the Multi-GPU has been enabled.

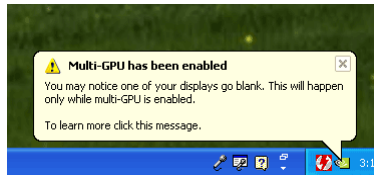

### **Important**

*If you want to remove one graphics card and quit the SLI function, make sure the "MultiGPU" function is disabled.*

## PCI (Peripheral Component Interconnect) Slot

The PCI slot supports LAN card, SCSI card, USB card, and other add-on cards that comply with PCI specifications.

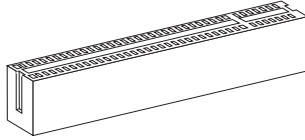

32-bit PCI Slot

### **Important**

*When adding or removing expansion cards, make sure that you unplug the power supply first. Meanwhile, read the documentation for the expansion card to configure any necessary hardware or software settings for the expansion card, such as jumpers, switches or BIOS configuration.*

## PCI Interrupt Request Routing

The IRQ, acronym of interrupt request line and pronounced I-R-Q, are hardware lines over which devices can send interrupt signals to the microprocessor. The PCI IRQ pins are typically connected to the PCI bus pins as follows:

	Order1	Order2	Order3	Order4
PCI Slot1	INT E#	INT F#	INT G#	INT H#

## LED STATUS INDICATORS

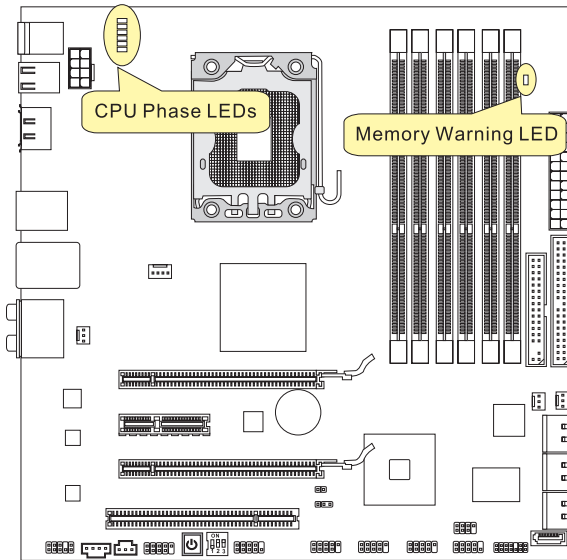

### CPU Phase LEDs

These LEDs indicate the current CPU power phase mode. Follow the instructions below to read.

■ Lights    □ Off

	CPU is in 1 phase power mode.		CPU is in 2 phase power mode.
	CPU is in 3 phase power mode.		CPU is in 4 phase power mode.
	CPU is in 5 phase power mode.		CPU is in 6 phase power mode.

### Memory Warning LED

Lights red when the incorrect memory installed into DIMM\_C0/ DIMM\_C1 (the DIMMs of 3rd channel).

# Chapter 3

## BIOS Setup

This chapter provides information on the BIOS Setup program and allows you to configure the system for optimum use.

You may need to run the Setup program when:

- An error message appears on the screen during the system booting up, and requests you to run SETUP.
- You want to change the default settings for customized features.

### ENTERING SETUP

---

Power on the computer and the system will start POST (Power On Self Test) process. When the message below appears on the screen, press <DEL> key to enter Setup.

#### Press DEL to enter SETUP

If the message disappears before you respond and you still wish to enter Setup, restart the system by turning it OFF and On or pressing the RESET button. You may also restart the system by simultaneously pressing <Ctrl>, <Alt>, and <Delete> keys.

#### **Important**

- *The items under each BIOS category described in this chapter are under continuous update for better system performance. Therefore, the description may be slightly different from the latest BIOS and should be held for reference only.*
- *Upon boot-up, the 1st line appearing after the memory count is the BIOS version. It is usually in the format:*

*A7593IMS V1.0 030509 where:*

*1st digit refers to BIOS maker as A = AMI, W = AWARD, and P = PHOENIX.*

*2nd - 5th digit refers to the model number.*

*6th digit refers to the chipset as I = Intel, N = NVIDIA, A = AMD and V = VIA.*

*7th - 8th digit refers to the customer as MS = all standard customers.*

*V1.0 refers to the BIOS version.*

*030509 refers to the date this BIOS was released.*



## Control Keys

<↑>	Move to the previous item
<↓>	Move to the next item
<←>	Move to the item in the left hand
<→>	Move to the item in the right hand
<Enter>	Select the item
<Esc>	Jumps to the Exit menu or returns to the main menu from a submenu
<+ /PU>	Increase the numeric value or make changes
<- /PD>	Decrease the numeric value or make changes
<F1>	General Help
<F4>	Enter the CPU Spec. menu, and read the CPU information
<F5>	Enter the Memory-Z menu, and read the memory information
<F6>	Load Optimized Defaults
<F8>	Load Fail-Safe Defaults
<F10>	Save all the CMOS changes and exit

## Getting Help

After entering the Setup menu, the first menu you will see is the Main Menu.

### Main Menu

The main menu lists the setup functions you can make changes to. You can use the arrow keys ( ↑ ↓ ) to select the item. The on-line description of the highlighted setup function is displayed at the bottom of the screen.

### Sub-Menu

If you find a right pointer symbol (as shown in the right view) appears to the left of certain fields that means a sub-menu can be launched from this field. A sub-menu contains additional options for a field parameter. You can use arrow keys ( ↑ ↓ ) to highlight



▶ SATA1  
▶ SATA2  
▶ SATA3  
▶ SATA4

the field and press <Enter> to call up the sub-menu. Then you can use the control keys to enter values and move from field to field within a sub-menu. If you want to return to the main menu, just press the <Esc >.

### General Help <F1>

The BIOS setup program provides a General Help screen. You can call up this screen from any menu by simply pressing <F1>. The Help screen lists the appropriate keys to use and the possible selections for the highlighted item. Press <Esc> to exit the Help

## THE MAIN MENU

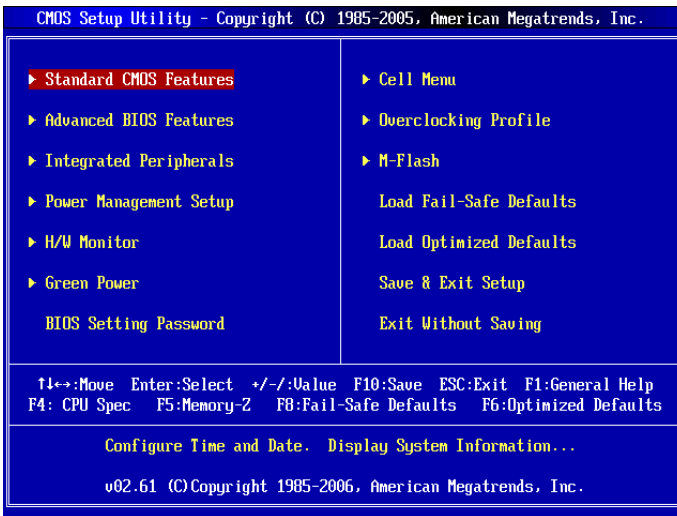

### ▶ Standard CMOS Features

Use this menu for basic system configurations, such as time, date etc.

### ▶ Advanced BIOS Features

Use this menu to setup the items of the BIOS special enhanced features.

### ▶ Integrated Peripherals

Use this menu to specify your settings for integrated peripherals.

### ▶ Power Management Setup

Use this menu to specify your settings for power management.

### ▶ H/W Monitor

This entry shows your PC health status.

### ▶ Green Power

Use this menu to specify the power phase.

### ▶ BIOS Setting Password

Use this menu to set the password for BIOS.

### ▶ Cell Menu

Use this menu to specify your settings for frequency/voltage control and overclocking.

**► Overclocking Profile**

Use this menu to save/ load your settings to/ from CMOS for BIOS.

**► M-Flash**

Use this menu to read/ flash the BIOS from storage drive (FAT/ FAT32 format only).

**► Load Fail-Safe Defaults**

Use this menu to load the default values set by the BIOS vendor for stable system performance.

**► Load Optimized Defaults**

Use this menu to load the default values set by the mainboard manufacturer specifically for optimal performance of the mainboard.

**► Save & Exit Setup**

Save changes to CMOS and exit setup.

**► Exit Without Saving**

Abandon all changes and exit setup.

## STANDARD CMOS FEATURES

The items in Standard CMOS Features Menu include some basic setup items. Use the arrow keys to highlight the item and then use the <PgUp> or <PgDn> keys to select the value you want in each item.

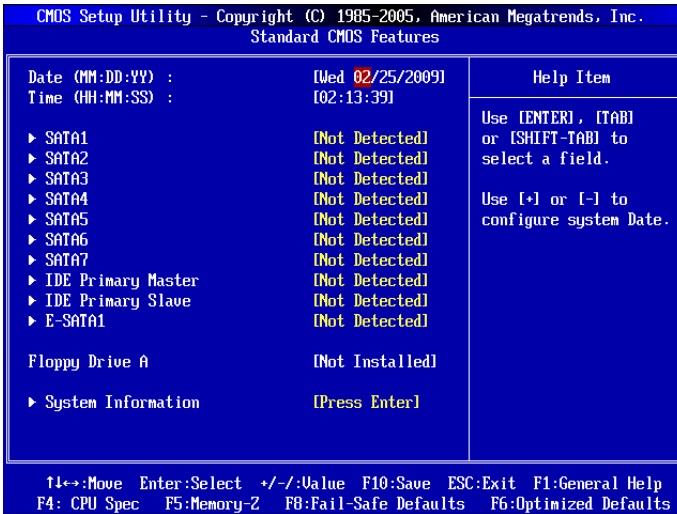

### ▶ Date (MM:DD:YY)

This allows you to set the system to the date that you want (usually the current date). The format is <day><month> <date> <year>.

[day] Day of the week, from Sun to Sat, determined by BIOS. Read-only.

[month] The month from Jan. through Dec.

[date] The date from 1 to 31 can be keyed by numeric function keys.

[year] The year can be adjusted by users.

### ▶ Time (HH:MM:SS)

This allows you to set the system time that you want (usually the current time). The time format is <hour> <minute> <second>.

► **SATA1~6 & 7/8 & 9/10 & IDE Primary Master/ Slave & E-SATA1/2**

Press <Enter> to enter the sub-menu, and the following screen appears.

CMOS Setup Utility - Copyright (C) 1985-2005, American Megatrends, Inc.	
SATA1	
SATA1	Help Item
Device :Hard Disk	
Vendor :MAXTOR STM3320620AS	
Size :320.0GB	

► **Device / Vendor / Size**

It will show the device information that you connected to the SATA connector.

### **Important**

*IDE Primary Master/ Slave, SATA 1~7 & E-SATA are appearing when you connect the HD devices to the IDE/ SATA/ E-SATA connectors on the mainboard.*

► **Floppy Drive A**

This item allows you to set the type of floppy drives installed.

► **System Information**

Press <Enter> to enter the sub-menu, and the following screen appears.

CMOS Setup Utility - Copyright (C) 1985-2005, American Megatrends, Inc.	
System Information	
	Help Item
Intel(R) Core(TM) i7 CPU 920 @ 2.67GHz	
CPUID/MicroCode 106A4/0F	
Core Frequency 2.66GHz (133x20)	
BIOS Version 01.0B4 02242009	
Physical Memory 1024MB	
Cache Size 1024 KB	
L3 Cache Size 8192 KB	

This sub-menu shows the CPU information, BIOS version and memory status of your system (read only).

## ADVANCED BIOS FEATURES

CMOS Setup Utility - Copyright (C) 1985-2005, American Megatrends, Inc.		
Advanced BIOS Features		
		Help Item
Full Screen Logo Display	[Enabled]	
Quick Booting	[Enabled]	
Boot Up Num-Lock LED	[On]	
IOAPIC Function	[Enabled]	Disabled: Displays normal POST messages. Enabled: Displays OEM Logo instead of POST messages.
MPS Table Version	[1.4]	
Primary Graphic's Adapter	[PCI-E]	
PCI Latency Timer	[64]	
▶ CPU Feature	[Press Enter]	
▶ Chipset Feature	[Press Enter]	
▶ Boot Sequence	[Press Enter]	
▶ Trusted Computing	[Press Enter]	

↑↓:Move Enter:Select +/-:Value F10:Save ESC:Exit F1:General Help  
F4: CPU Spec F5:Memory-Z F8:Fail-Safe Defaults F6:Optimized Defaults

### ▶ Full Screen Logo Display

This item enables this system to show the company logo on the boot-up screen. Settings are:

- [Enabled] Shows a still image (logo) on the full screen at boot.
- [Disabled] Shows the POST messages at boot.

### ▶ Quick Booting

Setting the item to [Enabled] allows the system to boot within 10 seconds since it will skip some check items.

### ▶ Boot Up Num-Lock LED

This setting is to set the Num Lock status when the system is powered on. Setting to [On] will turn on the Num Lock key when the system is powered on. Setting to [Off] will allow users to use the arrow keys on the numeric keypad.

### ▶ IOAPIC Function

This field is used to enable or disable the APIC (Advanced Programmable Interrupt Controller). Due to compliance with PC2001 design guide, the system is able to run in APIC mode. Enabling APIC mode will expand available IRQ resources for the system.

### ▶ MPS Table Version

This field allows you to select which MPS (Multi-Processor Specification) version to be used for the operating system. You need to select the MPS version supported by your operating system. To find out which version to use, consult the vendor of your operating system.

### ► Primary Graphic's Adapter

This setting specifies which graphic card is your primary graphics adapter.

### ► PCI Latency Timer

This item controls how long each PCI device can hold the bus before another takes over. When set to higher values, every PCI device can conduct transactions for a longer time and thus improve the effective PCI bandwidth. For better PCI performance, you should set the item to higher values.

### ► CPU Feature

Press <Enter> to enter the sub-menu and the following screen appears:

CMOS Setup Utility - Copyright (C) 1985-2005, American Megatrends, Inc.		
CPU Feature		
Hyper-Threading Function	[Enabled]	Help Item
Execute Bit Support	[Disabled]	When 'Disabled' only one thread per enabled core is enabled.
C1E Support	[Enabled]	
Overspeed Protection	[Enabled]	

### ► Hyper-Threading Function

The processor uses Hyper-Threading technology to increase transaction rates and reduces end-user response times. The technology treats the two cores inside the processor as two logical processors that can execute instructions simultaneously. In this way, the system performance is highly improved. If you disable the function, the processor will use only one core to execute the instructions. Please disable this item if your operating system doesn't support HT Function, or unreliability and instability may occur.

### ► Execute Bit Support

Intel's Execute Disable Bit functionality can prevent certain classes of malicious "buffer overflow" attacks when combined with a supporting operating system. This functionality allows the processor to classify areas in memory by where application code can execute and where it cannot. When a malicious worm attempts to insert code in the buffer, the processor disables code execution, preventing damage or worm propagation.

### ► C1E Support

To enable this item to read the CPU power consumption while idle. Not all processors support Enhanced Halt state (C1E).

### ► Overspeed Protection

This item is used to enable/ disable Overspeed Protection.

### ► Chipset Feature

Press <Enter> to enter the sub-menu and the following screen appears:

CMOS Setup Utility - Copyright (C) 1985-2005, American Megatrends, Inc.		
Chipset Feature		
HPET	[Disabled]	Help Item

### ▶ HPET

The HPET (High Precision Event Timers) is a component that is part of the chipset. You can enable it, and will provide you with the means to get to it via the various ACPI methods.

### ▶ Boot Sequence

Press <Enter> to enter the sub-menu and the following screen appears:

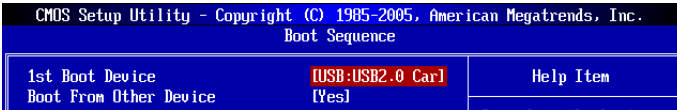

### ▶ 1st Boot Device

This item allows you to set the first boot device where BIOS attempts to load the disk operating system.

### ▶ Boot From Other Device

Setting the option to [Yes] allows the system to try to boot from other device, if the system fails to boot from 1st boot device.

### ▶ Trusted Computing

Press <Enter> to enter the sub-menu and the following screen appears:



### ▶ TCG/TPM SUPPORT

Setting the option to [Yes] enables TPM (Trusted Platform Module) to the system.



## INTEGRATED PERIPHERALS

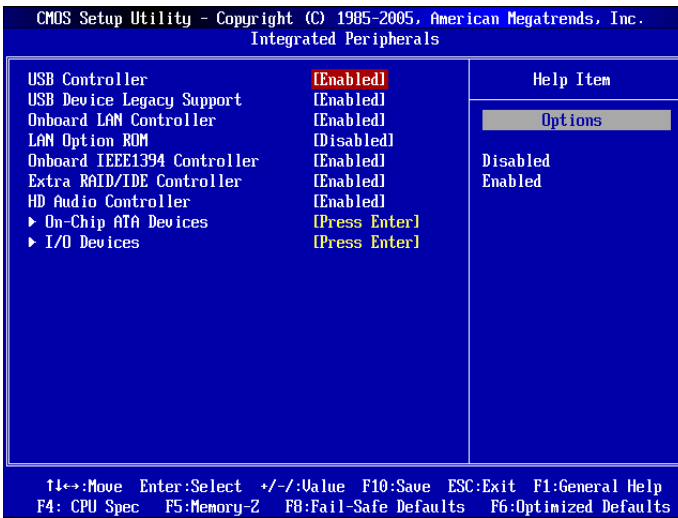

### ▶ USB Controller

This setting allows you to enable/disable the onboard USB controller.

### ▶ USB Device Legacy Support

Select [Enabled] if you need to use a USB-interfaced device in the operating system.

### ▶ Onboard LAN Controller

This setting allows you to enable/disable the onboard LAN controller.

### ▶ LAN Option ROM

This item is used to decide whether to invoke the Boot ROM of the onboard LAN.

### ▶ Onboard IEEE1394 Controller

This item allows you to enable/disable the onboard IEEE1394 controller.

### ▶ Extra RAID/ IDE Controller (JMB322 for SATA7 & E-SATA)

This item allows you to enable/disable the onboard extra RAID/ IDE controller.

### ▶ HD Audio Controller

This setting is used to enable/disable the onboard audio controller.

## BIOS Setup

### ► On-Chip ATA Devices

Press <Enter> to enter the sub-menu and the following screen appears:

CMOS Setup Utility - Copyright (C) 1985-2005, American Megatrends, Inc.		
On-Chip ATA Devices		
PCI IDE BusMaster	[Enabled]	Help Item
On-Chip SATA Controller	[Enabled]	
RAID Mode	[IDE]	ENABLED: BIOS uses

### ► PCI IDE BusMaster

This item allows you to enable/ disable BIOS to used PCI busmastering for reading/ writing to IDE drives.

### ► OnChip SATA Controller

This item allows users to enable or disable the SATA controller.

### ► RAID Mode

This item is used to select mode for SATA connectors.

### ► I/O Devices

Press <Enter> to enter the sub-menu and the following screen appears:

CMOS Setup Utility - Copyright (C) 1985-2005, American Megatrends, Inc.		
I/O Devices		
COM Port 1	[3F8/IRQ4]	Help Item

### ► COM Port 1

Select an address and corresponding interrupt for the serial port.

## POWER MANAGEMENT SETUP

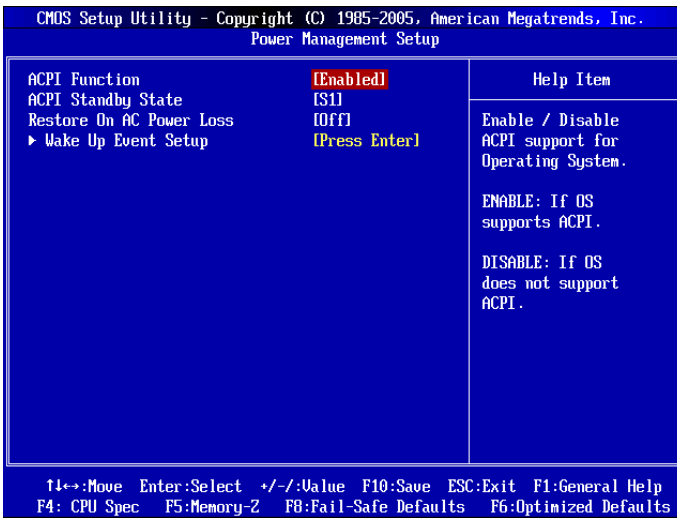

### Important

*S3-related functions described in this section are available only when the BIOS supports S3 sleep mode.*

#### ▶ ACPI Function

This item is to activate the ACPI (Advanced Configuration and Power Management Interface) Function. If your operating system is ACPI-aware, such as Windows 98SE/2000/ ME/ XP, select [Enabled].

#### ▶ ACPI Standby State

This item specifies the power saving modes for ACPI function. If your operating system supports ACPI, such as Windows 2000/ XP, you can choose to enter the Standby mode in S1(POS) or S3(STR) fashion through the setting of this field. Settings are:

- [S1]      The S1 sleep mode is a low power state. In this state, no system context is lost (CPU or chipset) and hardware maintains all system's context.
- [S3]      The S3 sleep mode is a lower power state where the information of system configuration and open applications/files is saved to main memory that remains powered while most other hardware components turn off to save energy. The information stored in memory will be used to restore the system when a "wake up" event occurs.

## BIOS Setup

### ► Restore On AC Power Loss

This item specifies whether your system will reboot after a power failure or interrupt occurs. Settings are:

- [Off] Always leaves the computer in the power off state.
- [On] Always leaves the computer in the power on state.
- [Last State] Restore the system to the status before power failure or interrupt occurred.

### ► Wake Up Event Setup

Press <Enter> and the following sub-menu appears.

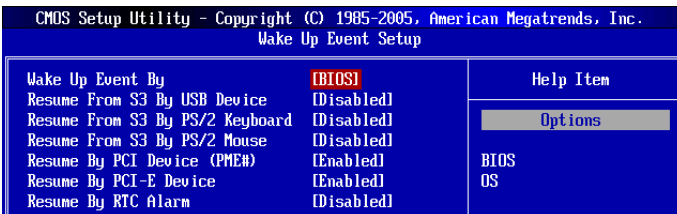

### ► Wake Up Event By

Setting to [BIOS] activates the following fields, and use the following fields to set the wake up events. Setting to [OS], the wake up events will be defined by OS.

### ► Resume From S3 By USB Device

The item allows the activity of the USB device to wake up the system from S3 (Suspend to RAM) sleep state.

### ► Resume From S3 By PS/2 Keyboard / Mouse

These items determine whether the system will be awakened from what power saving modes when input signal of the PS/2 keyboard/ mouse is detected.

### ► Resume By PCI Device (PME#)

When set to [Enabled], the feature allows your system to be awakened from the power saving modes through any event on PME (Power Management Event).

### ► Resume By PCI-E Device

When set to [Enabled], the feature allows your system to be awakened from the power saving modes through any event on PCIE device.

### ► Resume By RTC Alarm

The field is used to enable or disable the feature of booting up the system on a scheduled time/date.

## H/W MONITOR

CMOS Setup Utility - Copyright (C) 1985-2005, American Megatrends, Inc.		
H/W Monitor		
Chassis Intrusion	<b>Disabled</b>	Help Item
CPU Smart FAN Target	Disabled	Chassis Intrusion function
SYS FAN 1 Control	100%	
----- PC Health Status -----		
CPU Temperature	26°C/78°F	
IDH Temperature	47°C/116°F	
System Temperature	27°C/80°F	
CPU FAN Speed	2354 RPM	
SYS FAN 1 Speed	0 RPM	
SYS FAN 2 Speed	0 RPM	
SYS FAN 3 Speed	0 RPM	
CPU Vcore	1.208 V	
QPI Voltage	1.192 V	
3.3V	3.312 V	
5V	4.961 V	
12V	12.144 V	
↑←→:Move Enter:Select +/-:Value F10:Save ESC:Exit F1:General Help F4: CPU Spec F5:Memory-Z F8:Fail-Safe Defaults F6:Optimized Defaults		

### ► Chassis Intrusion

The field enables or disables the feature of recording the chassis intrusion status and issuing a warning message if the chassis is once opened. To clear the warning message, set the field to [Reset]. The setting of the field will automatically return to [Enabled] later.

### ► CPU Smart FAN Target

The mainboard provides the Smart Fan function which can control the CPU fan speed automatically depending on the current temperature to keep it with in a specific range. You can enable a fan target value here. If the current CPU fan temperature reaches to the target value, the smart fan function will be activated. It provides several sections to speed up for cooling down automatically.

### ► SYS FAN 1 Control

This item allows users to select how percentage of speed for the SYSFAN1.

### ► PC Health Status

- CPU/ System Temperature, CPU FAN/ SYS FAN 1/2/3 Speed, CPU Vcore, QPI Voltage, 3.3V, 5V, 12V

These items display the current status of all of the monitored hardware devices/components such as CPU voltage, temperatures and all fans' speeds.

## GREEN POWR

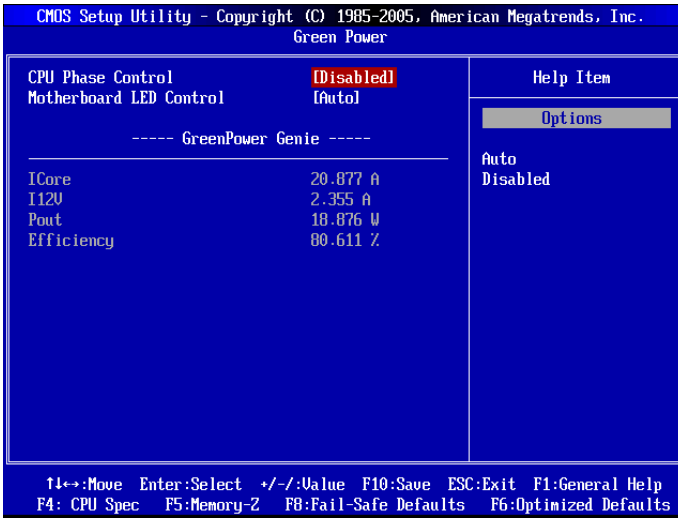

### ► CPU Phase Control

When set to [Auto], the hardware will auto adjust the CPU power phase according to the loading of CPU to reach the best power saving function.

### ► Motherboard LED Control

This item is used to enable/ disable the power phase LEDs of the motherboard.

----- GreenPower Genie-----

### ► ICore/ I12V

These items show the amperage of Core/ 12V. Read only.

### ► Pout/ Efficiency

These items show the power consumption & efficiency of the system. Read only.

## BIOS SETTING PASSWORD

---

When you select this function, a message as below will appear on the screen:

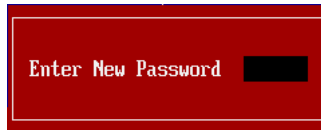

Type the password, up to six characters in length, and press <Enter>. The password typed now will replace any previously set password from CMOS memory. You will be prompted to confirm the password. Retype the password and press <Enter>. You may also press <Esc> to abort the selection and not enter a password.

To clear a set password, just press <Enter> when you are prompted to enter the password. A message will show up confirming the password will be disabled. Once the password is disabled, the system will boot and you can enter Setup without entering any password.

When a password has been set, you will be prompted to enter it every time you try to enter Setup. This prevents an unauthorized person from changing any part of your system configuration.

## CELL MENU

CMOS Setup Utility - Copyright (C) 1985-2005, American Megatrends, Inc.  
Cell Menu

Current Core Frequency	2.92GHz (133x22)	Help Item
Current DRAM Frequency	1066MHz	
Current QPI Frequency	4.800GT	
<hr/>		
▶ CPU Specifications	[Press Enter]	
Intel EIST	[Auto]	
Intel C-STATE tech	[Disabled]	
Base Clock (MHz)	[133]	
Intel Turbo Boost tech	[Enabled]	
Auto OverClock Technology	[Disabled]	
Adjusted Core Frequency (MHz)	2926	
▶ QPI Configuration	[Press Enter]	
<hr/>		
▶ MEMORY-Z	[Press Enter]	
▶ Advance DRAM Configuration	[Press Enter]	
Memory Ratio	[Auto]	
Adjusted DRAM Frequency (MHz)	1333	
Uncore Ratio	[Auto]	
Adjusted Uncore Frequency (MHz)	2666	
<hr/>		
▶ ClockGen Tuner	[Press Enter]	
Adjust PCI Frequency (MHz)	[Auto]	
Adjust PCI-E Frequency (MHz)	[100]	
Auto Disable DRAM/PCI Frequency	[Disabled]	
<hr/>		
CPU Load Line Calibration	[Disabled]	
CPU Voltage (V)	[Auto]	
CPU Vcore	1.056 V	
CPU PLL Voltage (V)	[Auto]	
QPI Voltage (V)	[Auto]	
DRAM Voltage (V)	[Auto]	
DDR_VREF_CA_A (V)	[Auto]	
DDR_VREF_CA_B (V)	[Auto]	
DDR_VREF_CA_C (V)	[Auto]	
DDR_VREF_DQ_A (V)	[Auto]	
DDR_VREF_DQ_B (V)	[Auto]	
DDR_VREF_DQ_C (V)	[Auto]	
NB Voltage (V)	[Auto]	
ICH Voltage (V)	[Auto]	
<hr/>		
Spread Spectrum	[Enabled]	

↑↓←→:Move Enter:Select +/-:Value F10:Save ESC:Exit F1:General Help  
F4: CPU Spec F5:Memory-Z F8:Fail-Safe Defaults F6:Optimized Defaults

**Important**

Change these settings only if you are familiar with the chipset.



### ► Current CPU / DRAM / QPI Frequency

These items show the current frequencies of CPU, Memory and QPI. Read-only.

### ► CPU Specifications

Press <Enter> to enter the sub-menu and the following screen appears. This submenu shows the information of installed CPU.

CMOS Setup Utility - Copyright (C) 1985-2005, American Megatrends, Inc.		
CPU Specifications		
Intel(R) Core(TM) i7 CPU	920 @ 2.67GHz	Help Item
CPUID/MicroCode	106A4/0F	
Core Frequency	2666MHz	
CPU Ratio	20	
CPU Stepping	C0	
Cache L1	128 KB	
Cache L2	1024 KB	
Cache L3	8192 KB	
Core VID	N/A	
Current Core VID	1.080 V	
Core Number	4	
► CPU Technology Support	[Press Enter]	

### ► CPU Technology Support

Press <Enter> to enter the sub-menu. This sub-menu shows the technologies that the installed CPU supported.

### ► Intel EIST

The Enhanced Intel SpeedStep technology allows you to set the performance level of the microprocessor whether the computer is running on battery or AC power. This field will appear after you installed the CPU which support speedstep technology.

### ► Intel C-STATE tech

C-state is a power management state that significantly reduces the power of the processor during idle. This field will appear after you installed the CPU which support c-state technology.

### ► Base Clock (MHz)

This item allows you to set the CPU Base clock (in MHz). You may overclock the CPU by adjusting this value. Please note the overclocking behavior is not guaranteed.

### ► Intel Turbo Boost tech

This item will appear when you install a CPU with Intel Turbo Boost technology. This item is used to enable/ disable Intel Turbo Boost technology. It can scale processor frequency higher dynamically when applications demand more performance and TDP headroom exists. It also can deliver seamless power scalability (Dynamically scale up, Speed-Step Down). It is the Intel newly technology within i7 CPU.

### ▶ Auto OverClock Technology

Setting this item to [Max FSB] allows the system to detect the FSB limitation for over-clocking automatically. If overlocking fails, you can try the lower FSB clock for over-clocking successfully.

### ▶ Adjusted CPU Frequency (MHz)

It shows the adjusted CPU frequency (Base clock x Ratio). Read-only.

### ▶ QPI Configuration

Press <Enter> to enter the sub-menu and the following screen appears.

CMOS Setup Utility - Copyright (C) 1985-2005, American Megatrends, Inc.		
QPI Configuration		
QPI Links Speed	[Full-Speed]	Help Item
QPI Frequency	[Auto]	

### ▶ QPI Links Speed

This item allows you to select the QPI links speed type.

### ▶ QPI Frequency

This item allows you to select the QPI frequency.

### ▶ Memory-Z

Press <Enter> to enter the sub-menu and the following screen appears.

CMOS Setup Utility - Copyright (C) 1985-2005, American Megatrends, Inc.		
MEMORY-Z		
▶ DIMM1 Memory SPD Information	[Press Enter]	Help Item

### ▶ DIMM1~6 Memory SPD Information

Press <Enter> to enter the sub-menu. The sub-menu displays the informations of installed memory.

### ▶ Advance DRAM Configuration

Press <Enter> to enter the sub-menu and the following screen appears.

CMOS Setup Utility - Copyright (C) 1985-2005, American Megatrends, Inc.		
Advance DRAM Configuration		
1N/2N Memory Timing	[Auto]	Help Item
CAS Latency(CL)	[Auto]	
tRCD	[Auto]	
tRP	[Auto]	Also called "Command Rate"; the delay cycle between the memory controller start to
tRAS	[Auto]	
Advanced Memory Setting	[Auto]	

► **1N/2N Memory Timing**

This item controls the SDRAM command rate. Select [1N] makes SDRAM signal controller to run at 1N (N=clock cycles) rate. Selecting [2N] makes SDRAM signal controller run at 2N rate.

► **CAS Latency (CL)**

This controls the CAS latency, which determines the timing delay (in clock cycles) before SDRAM starts a read command after receiving it.

► **tRCD**

When DRAM is refreshed, both rows and columns are addressed separately. This setup item allows you to determine the timing of the transition from RAS (row address strobe) to CAS (column address strobe). The less the clock cycles, the faster the DRAM performance.

► **tRP**

This setting controls the number of cycles for Row Address Strobe (RAS) to be allowed to precharge. If insufficient time is allowed for the RAS to accumulate its charge before DRAM refresh, refresh may be incomplete and DRAM may fail to retain data. This item applies only when synchronous DRAM is installed in the system.

► **tRAS**

This setting determines the time RAS takes to read from and write to memory cell.

► **Advance Memory Setting**

Setting to [Auto] enables the advance memory timing automatically to be determined by BIOS. Setting to [Manual] allows you to set advanced memory timings.

► **Memory Ratio**

This item allows you to set the memory multiplier.

► **Adjusted DRAM Frequency (MHz)**

It shows the adjusted DDR Memory frequency. Read-only.

► **Uncore Ratio**

This item allows you to set the uncore (clock speed of the L3 cache and memory controller) multiplier.

► **Adjusted Uncore Frequency (MHz)**

It shows the adjusted uncore frequency (uncore ratio x base clock, the clock speed of the L3 cache and memory controller). Read-only.

► **ClockGen Tuner**

Press <Enter> to enter the sub-menu and the following screen appears.



### ▶ CPU Amplitude Control/ PCI Express Amplitude Control

These items are used to select the CPU/ PCI Express clock amplitude.

### ▶ CPU CLK Skew/ IOH CLK Skew

These items are used to select the CPU/ IOH chipset clock skew. They can help CPU to reach the higher overclocking performance.

### ▶ Adjust PCI Frequency (MHz)

This field allows you to select the PCI frequency (in MHz).

### ▶ Adjust PCI-E Frequency (MHz)

This field allows you to select the PCIe frequency (in MHz).

### ▶ Auto Disable DRAM/PCI Frequency

When set to [Enabled], the system will remove (turn off) clocks from empty DIMM and PCI slots to minimize the electromagnetic interference (EMI).

### ▶ CPU Load Line Calibration

When set to [Enabled], system will automatically fix the vcore droop issue of CPU, and the CPU can receive stable voltage in overclocking.

### ▶ CPU Voltage (V)/ CPU Vcore/ CPU PLL Voltage (V)/ QPI Voltage (V)/ DRAM Voltage (V)/ DDR\_VREF\_CA\_A Voltage (V)/ DDR\_VREF\_CA\_B Voltage (V)/ DDR\_VREF\_CA\_C Voltage (V)/ DDR\_VREF\_DQ\_A Voltage (V)/ DDR\_VREF\_DQ\_B Voltage (V)/ DDR\_VREF\_DQ\_C Voltage (V)/ NB Voltage (V)/ ICH Voltage (V)

These items are used to adjust the voltage of CPU, Memory and chipset.

### ▶ Spread Spectrum

When the mainboard's clock generator pulses, the extreme values (spikes) of the pulses create EMI (Electromagnetic Interference). The Spread Spectrum function reduces the EMI generated by modulating the pulses so that the spikes of the pulses are reduced to flatter curves. If you do not have any EMI problem, leave the setting at Disabled for optimal system stability and performance. But if you are plagued by EMI, set to Enabled for EMI reduction. Remember to disable Spread Spectrum if you are overclocking because even a slight jitter can introduce a temporary boost in clock speed which may just cause your overclocked processor to lock up.

## **Important**

- *If you do not have any EMI problem, leave the setting at [Disabled] for optimal system stability and performance. But if you are plagued by EMI, select the value of Spread Spectrum for EMI reduction.*
- *The greater the Spread Spectrum value is, the greater the EMI is reduced, and the system will become less stable. For the most suitable Spread Spectrum value, please consult your local EMI regulation.*
- *Remember to disable Spread Spectrum if you are overclocking because even a slight jitter can introduce a temporary boost in clock speed which may just cause your overclocked processor to lock up.*

## **Important**

### **Failed Overclocking Resolution**

*This motherboard supports overclocking greatly. However, please make sure your peripherals and components are bearable for some special settings. Any operation that exceeds product specification is not recommended. Any risk or damage resulting from improper operation will not be under our product warranty.*

**Two ways to save your system from failed overclocking...**

- **Reboot**

*Press the Power button to reboot the system three times. Please note that, to avoid electric current to affect other devices or components, we suggest an interval of more than 10 seconds among the reboot actions.*



*At the fourth reboot, BIOS will determine that the previous overclocking is failed and restore the default settings automatically. Please press any key to boot the system normally when the following message appears on screen.*

**Warning !!! The previous overclocking had failed,  
and system will restore its defaults setting,  
Press any key to continue.....**

- **Clear CMOS**

*Please refer to "Chapter 2" for more information about how to clear CMOS data.*

## OVERCLOCKING PROFILE

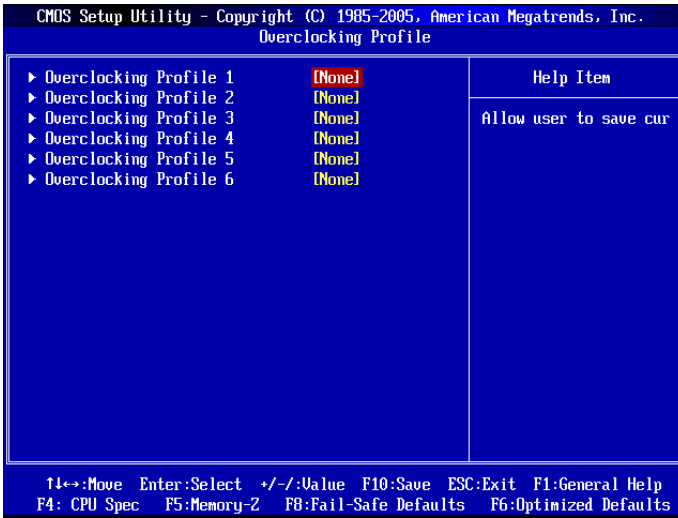

### ▶ Overclocking Profile 1/ 2/ 3/ 4/ 5/ 6

These items are used to save the current settings to the selected profile, and they are also used to load the settings from the selected profile.

## M-FLASH

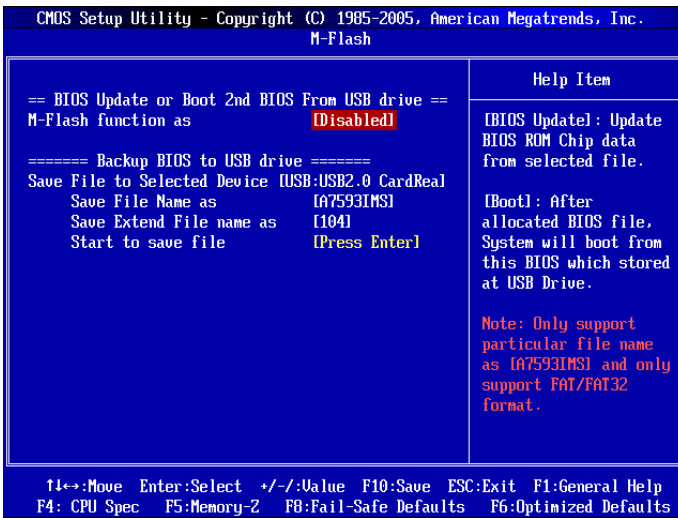

== BIOS Update or Boot 2nd BIOS From USB drive==

### ► M-Flash function as

M-Flash function allows you to flash BIOS from USB drive/ storage drive (FAT/ FAT32 format only), or allows the system to boot from the BIOS file inside USB drive (FAT/ FAT32 format only).

[Disabled] Disable M-Flash function.

[BIOS Update] Flash BIOS via the USB/ Storage drive directly. Update BIOS ROM chip data from selected file, which was be download from official website and must be saved in the root directory of the USB/ Storage drive. It only supports particular file name, which is the official BIOS file name from us.

[Boot] After allocated particular BIOS file, system will boot from this BIOS file which saved in the root directory of USB drive. System will skip MB ROM chip data and boot with this particular BIOS inside USB drive. Note: this option is for USB drive only.

**Important**

- Please refer to the block diagram below about the M-Flash function.

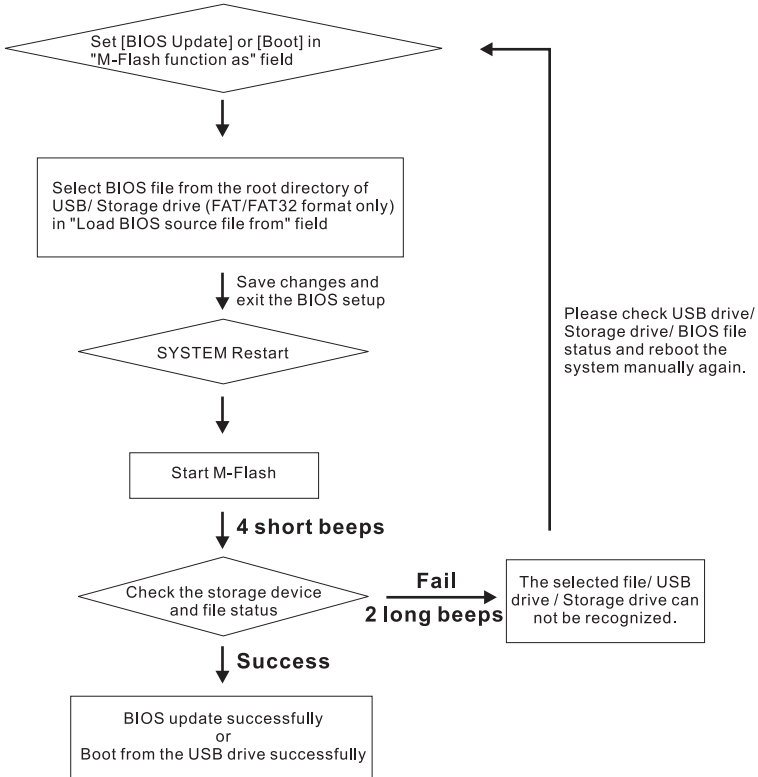

- Due to the special design of some graphics cards will cause dark screen during M-flash operation, and you may refer the beeps from the system to confirm the current M-flash process.



**► Load BIOS source file from**

When the M-Flash function as sets to [Boot] or [BIOS Update], this item is selectable. Use this item to select particular BIOS file from the USB/ Storage (FAT/32 format only) drive.

== Backup BIOS to USB drive ==

The following fields are used to read the onboard BIOS ROM data, and save it to USB drive/ storage drive.

**► Save File to Selected Device**

Please setup a specific folder in specific USB drive/ storage drive to save BIOS file from BIOS ROM chip data. Note: it only supports FAT/ FAT32 file system drive.

**► Save File Name as**

Please setup a specific name for the BIOS file, which will be saved into the USB drive/ storage drive. Note: we suggest you using the official name as the default name.

**► Save Extend File name as**

Please setup a specific extend name for the BIOS file, which will be saved into the USB drive/ storage drive. Note: we suggest you using [ROM] as default name.

**► Start to save file**

Press "Enter" and select "OK" the system will start to save the onboard ROM chip data to the selected USB drive/ storage drive.

## LOAD FAIL-SAFE/ OPTIMIZED DEFAULTS

---

The two options on the main menu allow users to restore all of the BIOS settings to the default Fail-Safe or Optimized values. The Optimized Defaults are the default values set by the mainboard manufacturer specifically for optimal performance of the mainboard. The Fail-Safe Defaults are the default values set by the BIOS vendor for stable system performance.

When you select Load Fail-Safe Defaults, a message as below appears:



Selecting Ok and pressing Enter loads the BIOS default values for the most stable, minimal system performance.

When you select Load Optimized Defaults, a message as below appears:



Selecting Ok and pressing Enter loads the default factory settings for optimal system performance.

# *Appendix A*

## *Realtek Audio*

The Realtek audio provides 10-channel DAC that simultaneously supports 7.1 sound playback and 2 channels of independent stereo sound output (multiple streaming) through the Front-Out-Left and Front-Out-Right channels.

## INSTALLING THE REALTEK HD AUDIO DRIVER

You need to install the HD audio driver for Realtek audio codec to function properly before you can get access to 2-, 4-, 6-, 8- channel or 7.1+2 channel audio operations. Follow the procedures described below to install the drivers for different operating systems.

### Installation for Windows® XP

For Windows® XP, you must install Windows® XP Service Pack3 or later before installing the driver.

The following illustrations are based on Windows® XP environment and could look slightly different if you install the drivers in different operating systems.

1. Insert the application DVD into the DVD-ROM drive. The setup screen will automatically appear.
2. Click Realtek HD Audio Drivers button.



### **Important**

*The HD Audio Configuration software utility is under continuous update to enhance audio applications. Hence, the program screens shown here in this section may be slightly different from the latest software utility and shall be held for reference only.*

3. Click Next to install the Realtek High Definition Audio Driver.

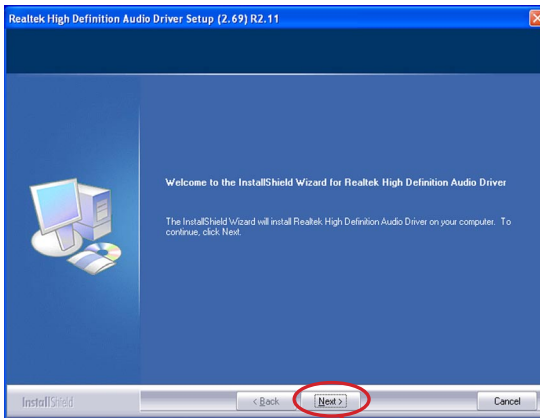

Click here

4. Click Finish to restart the system.

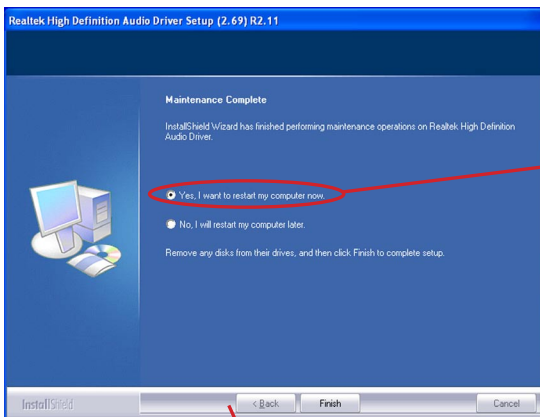

Select this option

Click here

## SOFTWARE CONFIGURATION

After installing the audio driver, you are able to use the 2-, 4-, 6- or 8- channel audio feature now. Click the audio icon  from the system tray at the lower-right corner of the screen to activate the HD Audio Configuration. It is also available to enable the audio driver by clicking the **Realtek HD Audio Manager** from the Control Panel.

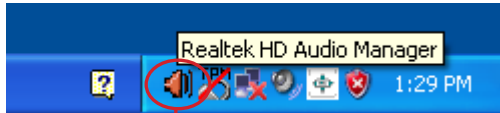

Double click

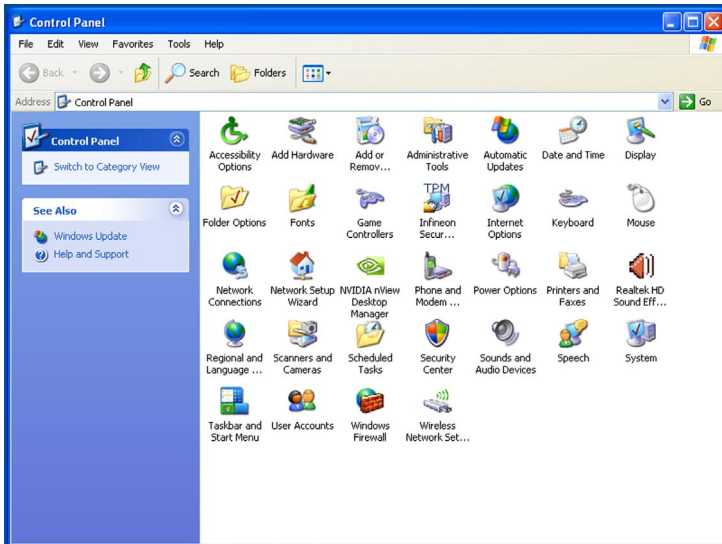

## Sound Effect

Here you can select a sound effect you like from the **Environment** list.



### ■ Environment Simulation

You will be able to enjoy different sound experience by pulling down the arrow, totally 23 kinds of sound effect will be shown for selection. Realtek HD Audio Sound Manager also provides five popular settings “Stone Corridor”, “Bathroom”, “Sewer pipe”, “Arena” and “Auditorium” for quick enjoyment.

You may choose the provided sound effects, and the equalizer will adjust automatically. If you like, you may also load an equalizer setting or make an new equalizer setting to save as an new one by using the “Load EQ Setting” and “Save Preset” button, click “Reset EQ Setting” button to use the default value, or click “Delete EQ Setting” button to remove a preset EQ setting.

There are also other pre-set equalizer models for you to choose by clicking “Others” under the Equalizer part.

■ Equalizer Selection

Equalizer frees users from default settings; users may create their own preferred settings by utilizing this tool.

10 bands of equalizer, ranging from 100Hz to 16KHz.

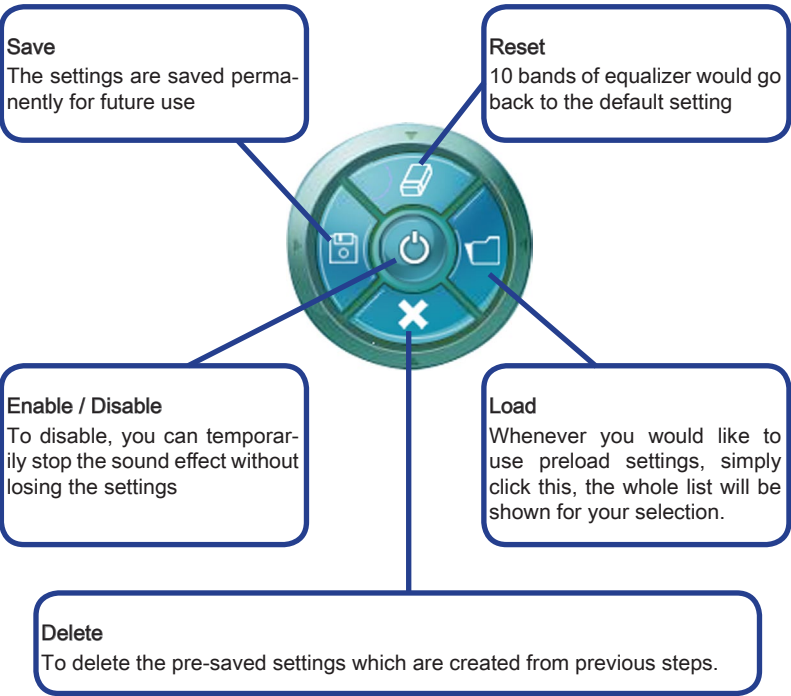
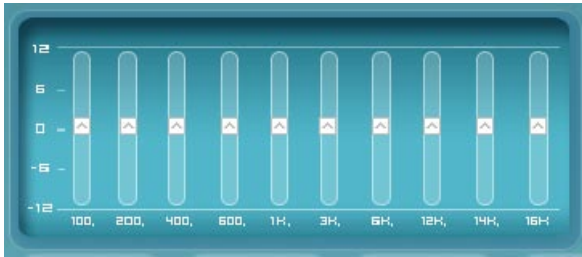



### Frequently Used Equalizer Setting

Realtek recognizes the needs that you might have. By leveraging our long experience at audio field, Realtek HD Audio Sound Manager provides you certain optimized equalizer settings that are frequently used for your quick enjoyment.

[How to Use It]

Other than the buttons “Pop”, “Live”, “Club” & “Rock” shown on the page, to pull down the arrow in “Others” you will find more optimized settings available to you.

#### ■ Karaoke Mode

Karaoke mode brings Karaoke fun back home. Simply using the music you usually play, Karaoke mode can help you eliminate the vocal of the song or adjust the key to accommodate your range.

1. Vocal Cancellation: Single click on “Voice Cancellation” the vocal of the song would be eliminated, while the background music is still in place, and you can be that singer!
2. Key Adjustment: Using “Up / Down Arrow” to find a key which better fits your vocal range.

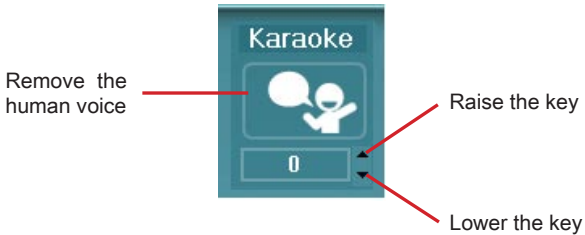

### Mixer

In the Mixer part, you may adjust the volumes of the rear and front panels individually.

#### ■ Adjust Volume

You can adjust the volume of the speakers that you plugged in front or rear panel by select the Realtek HD Audio rear output or Realtek HD Audio front output items.



### Important

*Before set up, please make sure the playback devices are well plugged in the jacks on the rear or front panel. The Realtek HD Audio front output item will appear after you plugging the speakers into the jacks on the front panel.*

#### ■ Multi-Stream Function

Realtek audio supports an outstanding feature called Multi-Stream, which means you may play different audio sources simultaneously and let them output respectively from the indicated rear panel or front panel. This feature is very helpful when 2 people are using the same computer together for different purposes.

Click the  button and the Mixer ToolBox menu will appear. Then check the Enable playback multi-streaming and click OK to save the setup.

### Important

*You have to plug audio device into the jacks on the rear and front panel first before enable the multi-stream function.*

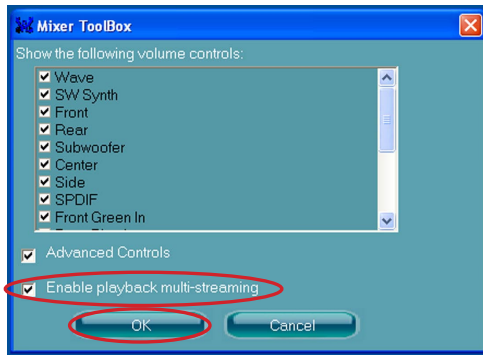

When you are playing the first audio source (for example: use Windows Media Player to play DVD/VCD), the output will be played from the rear panel, which is the default setting.

Then you must to select the **Realtek HD Audio 2nd output** from the scroll list first, and use a different program to play the second audio source (for example: use Winamp to play MP3 files). You will find that the second audio source (MP3 music) will come out from the Line-Out audio jack of Front Panel.



## ■ Playback control



Tool Mute

### Playback device

This function is to let you freely decide which ports to output the sound. And this is essential when multi-streaming playback enabled.

- Realtek HD Audio Rear Output
- Realtek HD Audio Front Output

### Mute

You may choose to mute single or multiple volume controls or to completely mute sound output.

### Tool

- Show the following volume controls

This is to let you freely decide which volume control items to be displayed.

- Advanced controls
- Enable playback multi-streaming

With this function, you will be able to have an audio chat with your friends via headphone (stream 1 from front panel) while still has music (stream 2 from back panel) in play. At any given period, you can have maximum 2 streams operating simultaneously.



## ■ Recording control



### Mute

You may choose to mute single or multiple volume controls or to completely mute sound input.

### Tool

- Show the following volume controls

This is to let you freely decide which volume control items to be displayed.

- Enable recording multi-streaming

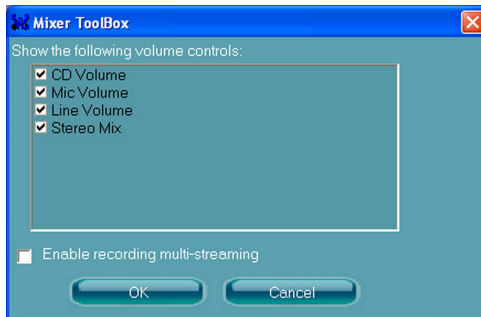

### **Important**

Realtek audio allows you to record the CD, Line, Mic and Stereo Mix channels simultaneously, frees you from mixing efforts. At any given period, you may choose 1 of the following 4 channels to record.

## Audio I/O

In this tab, you can easily configure your multi-channel audio function and speakers. You can choose a desired multi-channel operation here.

- **Headphone** for the common headphone
- **2CH Speaker** for Stereo-Speaker Output
- **4CH Speaker** for 4-Speaker Output
- **6CH Speaker** for 5.1-Speaker Output
- **8CH Speaker** for 7.1-Speaker Output



### ■ Speaker Configuration:

1. Plug the speakers in the corresponding jack.
2. Dialogue “connected device” will pop up for your selection. Please select the device you have plugged in.
  - If the device is being plugged into the correct jack, you will be able to find the icon beside the jack changed to the one that is same as your device.
  - If not correct, Realtek HD Audio Manager will guide you to plug the device into the correct jack.

## ■ Connector Settings

Click  to access connector settings.



### Disable front panel jack detection (optional)

Jack detection function only works with HD audio front panel. Please check if front jacks on your system are so-called AC'97 jacks. If so, please check this item to disable front panel jack detection.

**Mute rear panel output when front headphone plugged in.**

**Enable auto popup dialogue, when device has been plugged in**

Once this item checked, the dialog "Connected device" would automatically pop up when device plugged in.

### ■ S/PDIF

Short for Sony/Philips Digital Interface, a standard audio file transfer format. S/PDIF allows the transfer of digital audio signals from one device to another without having to be converted first to an analog format. Maintaining the viability of a digital signal prevents the quality of the signal from degrading when it is converted to analog.

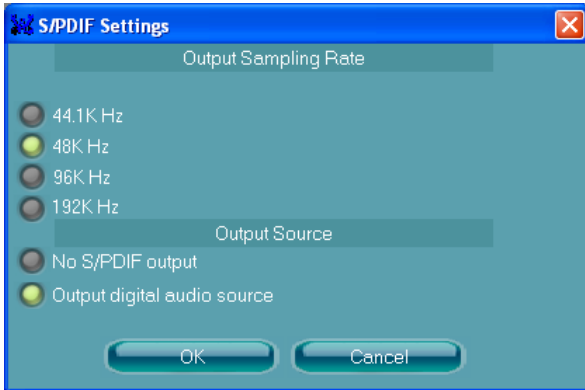

#### Output Sampling Rate

44.1KHz: This is recommend while playing CD.

48KHz: This is recommended while playing DVD or Dolby.

96KHz: This is recommended while playing DVD-Audio.

192KHz: This is recommended while playing High quality Audio.

#### Output Source

Output digital audio source: The digital audio format (such as .wav, .mp3,.midi etc) will come out through S/PDIF-Out.

S/PDIF-in to S/PDIF -out pass though mode: The data from S/PDIF-In can be real-time played from S/PDIF-Out.



### ■ Test Speakers

You can select the speaker by clicking it to test its functionality. The one you select will light up and make testing sound. If any speaker fails to make sound, then check whether the cable is inserted firmly to the connector or replace the bad speakers with good ones. Or you may click the **auto test**  button to test the sounds of each speaker automatically.

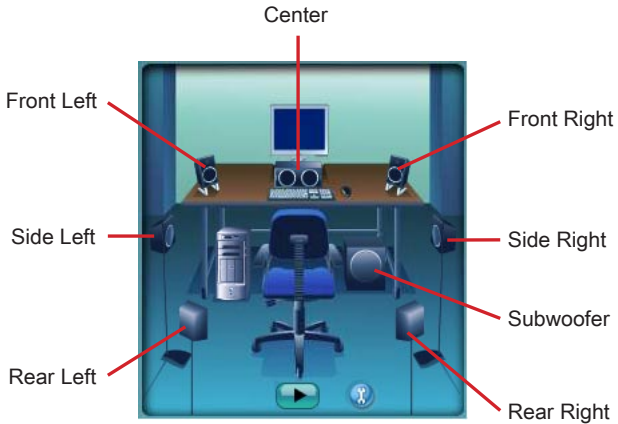

## Microphone

In this tab you may set the function of the microphone. Select the **Noise Suppression** to remove the possible noise during recording, or select **Acoustic Echo Cancellation** to cancel the acoustic echo during recording.

Acoustic Echo Cancellation prevents playback sound from being recorded by microphone together with your sound. For example, you might have chance to use VOIP function through Internet with your friends. The voice of your friend will come out from speakers (playback). However, the voice of your friend might also be recorded into your microphone then go back to your friend through Internet. In that case, your friend will hear his/her own voice again. With AEC (Acoustic Echo Cancellation) enabled at your side, your friend can enjoy the benefit with less echo.



### 3D Audio Demo

In this tab you may adjust your 3D positional audio before playing 3D audio applications like gaming. You may also select different environment to choose the most suitable environment you like.



## Information

In this tab it provides some information about this HD Audio Configuration utility, including Audio Driver Version, DirectX Version, Audio Controller & Audio Codec. You may also select the language of this utility by choosing from the **Language** list.



Also there is a selection **Show icon in system tray**. Switch it on and an icon  will show in the system tray. Right-click on the icon and the **Audio Accessories** dialogue box will appear which provides several multimedia features for you to take advantage of.



## HARDWARE SETUP

### Connecting the Speakers

When you have set the Multi-Channel Audio Function mode properly in the software utility, connect your speakers to the correct phone jacks in accordance with the setting in software utility.

- 2-Channel Mode for Stereo-Speaker Output

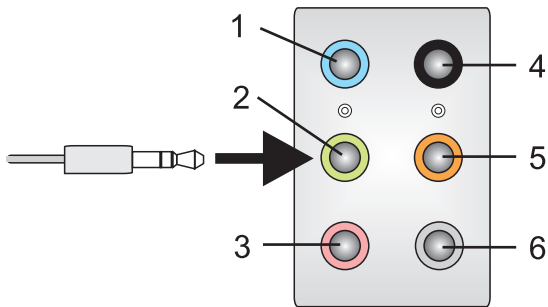

- 1] Line In
- 2] Line Out (Front channels)
- 3] MIC
- 4] No function
- 5] No function
- 6] No function

■ 4-Channel Mode for Stereo-Speaker Output

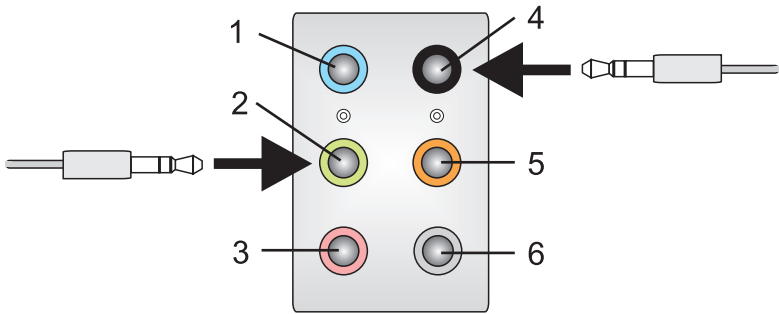

- 1] Line In
- 2] Line Out (Front channels)
- 3] MIC
- 4] Line Out (Rear channels)
- 5] No function
- 6] No function

■ 6-Channel Mode for Stereo-Speaker Output

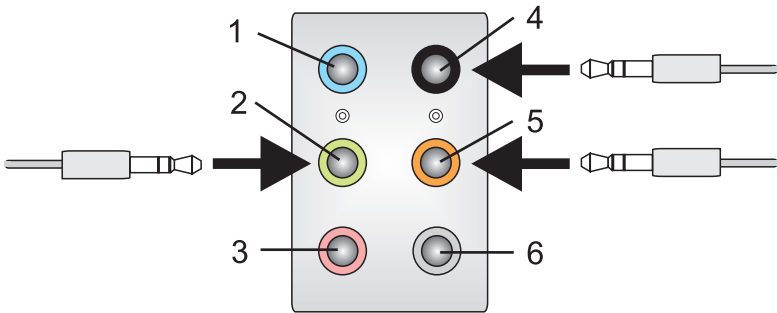

- 1] Line In
- 2] Line Out (Front channels)
- 3] MIC
- 4] Line Out (Rear channels)
- 5] Line Out (Center and Subwoofer channel)
- 6] No function

■ 8-Channel Mode for Stereo-Speaker Output

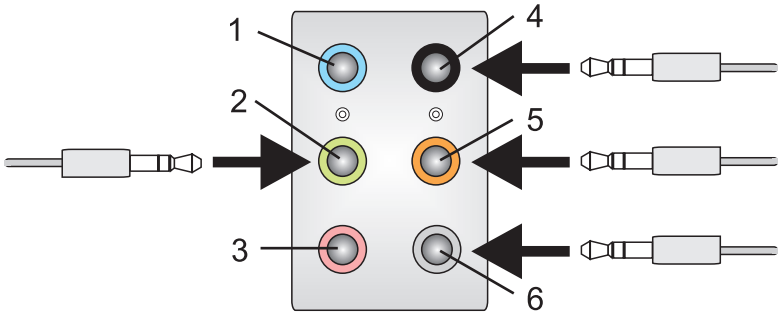

- 1] Line In
- 2] Line Out (Front channels)
- 3] MIC
- 4] Line Out (Rear channels)
- 5] Line Out (Center and Subwoofer channel)
- 6] Line Out (Side channels)

**Important**

To enable 7.1 channel audio-out function on Windows Vista operating system, you have to install the Realtek Audio Driver. Or, the mainboard will support 5.1 channel audio-out only.



# *Appendix B*

## *Overclocking Center*

Overclocking Center, the most useful and powerful utility that MSI has spent much research and efforts to develop, helps users to monitor or configure the hardware status of MSI Mainboard in windows, such as CPU clock, voltage, fan speed and temperature.

Before you install the Overclocking Center, please make sure the system has meet the following requirements:

1. 256MB system memory.
2. CD-ROM drive for software installation.
3. Operation system: Windows XP or up.
4. DotNet Frame Work 2.0

### ACTIVATING OVERCLOCKING CENTER

Once you have your Overclocking Center installed (locate the setup source file in the setup CD accompanying with your mainboard, path: **Utility** → **MSI Utility** → **Overclocking Center**), it will have a short cut icon on the desktop, and a short cut path in your “Start-up” menu. You may double-click on each icon to activate Overclocking Center.

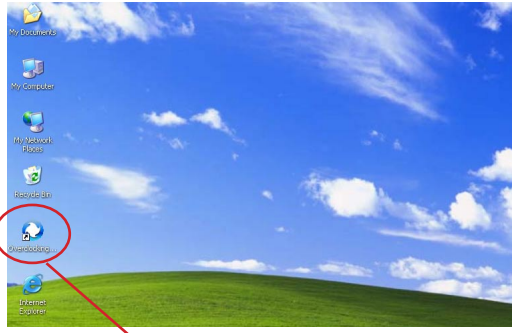

short-cut icon on the desktop

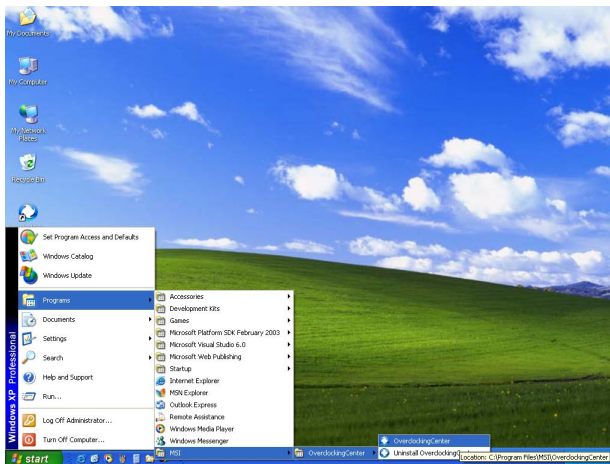

short-cut path in the start-up menu  
(path: Start-->Program Files-->MSI-->Overclocking Center-->Overclocking Center)



## Memory

Click Memory to read the information of each memory DIMM slot. You can select a DIMM slot you want to read from the SPD list.

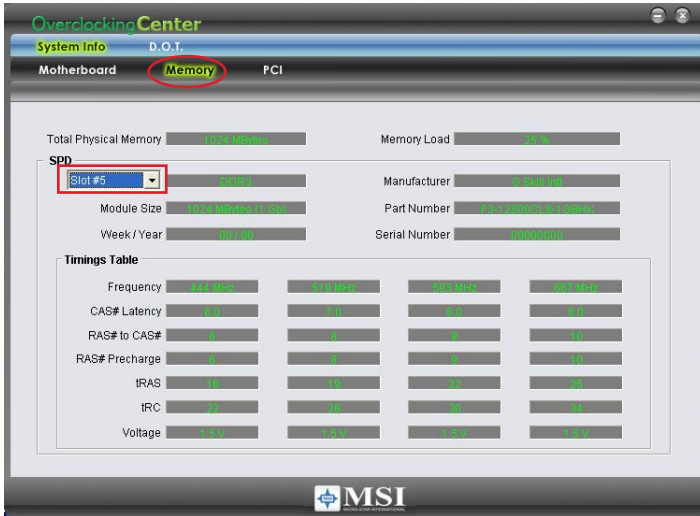

## PCI

Click PCI to read the information of devices on the mainboard.

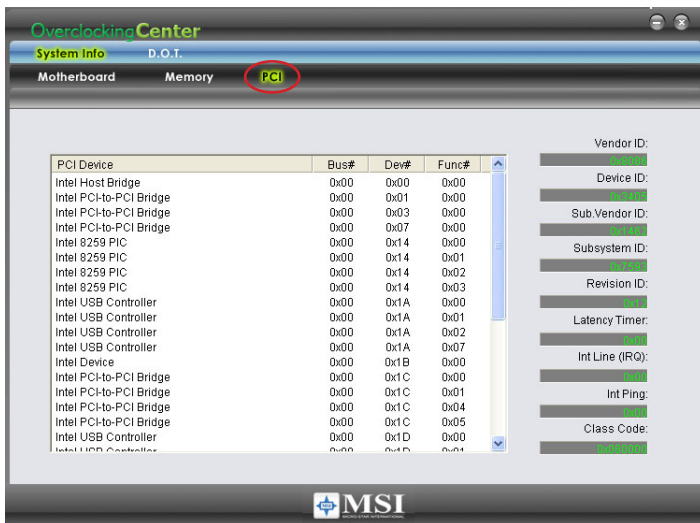

## DOT

Click DOT to enter the DOT screen. In DOT, you can select the basic setting to reach optimal performance in Basic menu or you can adjust advanced values for overclocking in Advance menu.

### Basic

In the Basic menu, it provides one default setting and four common settings for different environments. You may choose one of the settings that you need. The settings in Basic menu are not adjustable.



### **Important**

You may change the values of each environment setting/ default setting in Advance menu. Please refer the following section for more details.

## Advance

In the Advance menu, you can adjust the values for each environment setting/ default setting. Click the Cooling/ Silence/ Default/ Game/ Cinema button to enter its setting menu. Please refer to the following descriptions to adjust the values and save them.

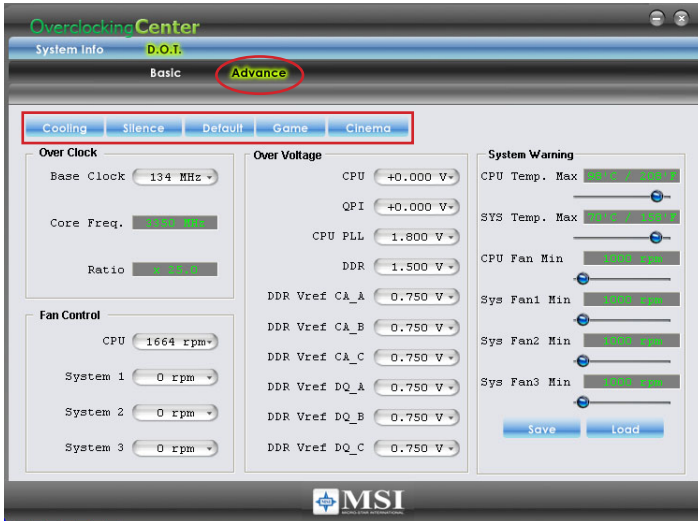

In each setting menu, you can select desired values for manual overclocking. Simply click the right side of the button which arranges an arrow sign, and a drop-down menu will appear below the button, then select a value.



Click the arrow sign and the drop-down menu will appear.

In the “System Warning” block, you can set the maximum CPU/ system temperature and the minimum CPU/ system fan speed by using the scroll bar. The system will pop-up a warning message to warning you when the temperature/ fan speed is over/ lower the values you set.

Set the thresholds of CPU temperature & CPU FAN speed.

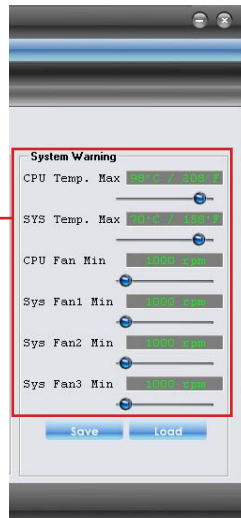

After you adjust the values in setting menu, you can save it for future use.



Click the Save button, and enter a name in the empty box. Then, click Save button again to save the settings.

### **Important**

*It provides you to save up to 20 user settings.*

Click the Load button and choose a saved user setting to load the settings for the system.

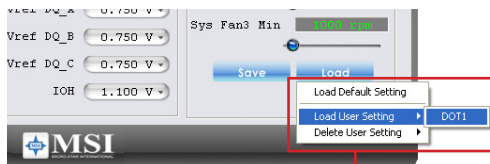

Click the Load button, and choose a saved user setting.

### **Important**

*Every time you turn-off the system, the settings will be restored to the factory default. If you want to use the saved settings, you have to load it after entering the operating system every time.*