

PARTS AND OPERATION MANUAL

MQ POWER DCA-40SSAI WHISPERWATT™ GENERATOR

© COPYRIGHT 2001, MULTIQIP INC.

PARTS LIST NO.M3340163804

FINAL COPY



MULTIQIP INC.

18910 WILMINGTON AVE.
CARSON, CALIFORNIA 90746
310-537-3700
800-421-1244
FAX: 310-537-3927

PARTS DEPARTMENT:

800-427-1244
FAX: 800-672-7877

SERVICE DEPARTMENT:

800-835-2551
FAX: 310-638-8046

E-mail: mq@multiquip.com • www.multiquip.com



WARNING



CALIFORNIA--Proposition 65 Warning

Engine exhaust and some of its constituents are known to the State of California to cause cancer, birth defects and other reproductive harm.

HERE'S HOW TO GET HELP

*PLEASE HAVE THE MODEL AND SERIAL NUMBER
ON-HAND WHEN CALLING*

PARTS DEPARTMENT

800/427-1244 or 310/537-3700

FAX: 800/672-7877 or 310/637-3284

SERVICE DEPARTMENT

800/835-2551 or 310/537-3700

FAX: 310/638-8046

WARRANTY DEPARTMENT

800/835-2551 or 310/537-3700

FAX: 310/638-8046

MAIN

800/421-1244 or 310/537-3700

FAX: 310/537-3927

TABLE OF CONTENTS

Here's How To Get Help 3
 Table Of Contents 4
 Parts Ordering Procedures 5
 Rules for Safe Operation 6-9
 Towing and Transportation 10
 Trailer Safety Guidelines 11-17
 Trailer Wiring Diagram 18
 Electric Brake Troubleshooting 19
 Hydraulic Brake Troubleshooting 20
 Operation and Safety Decals 21-22
 DCA-40SSAI Specifications 23
 General Information 24
 Major Components 25
 Dimensions 26-27
 Control Panel Descriptions 28-29
 Engine Operating Panel Descriptions 30-31
 Output Terminal Panel Description 32-33
 Output Amperage Setup 34-35
 Output Voltage Setup 36-39
 Installation 40-41
 Pre Setup 42-45
 Load Application 46
 Generator Start-up Procedure 47-49
 Generator Shutdown Procedure 50
 Maintenance 52-55
 Engine Wiring Diagram 56-57
 Generator Wiring Diagram 58
 Engine Troubleshooting 60-62
 Explanation of Codes in Remarks Column 64
 Suggested Spare Parts 65

ISUZU 4BD1 ENGINE

Cylinder Head Cover Assembly 94-95
 Cylinder Block Assembly 96-99
 Timing Gear Assembly 100-101
 Flywheel Housing Assembly 102-103
 Oil Pan Assembly 104-105
 Oil Pump Assembly 106-107
 Crankshaft Piston, Flywheel Assembly 108-109
 Valve Assembly 110-111
 Oil and Fuel Filter Assembly 112-113
 Oil Piping Assembly 114-115
 Cooling Assembly 116-117
 Air Intake and Exhaust Assembly 118-119
 Fuel Injection Assembly 120-121
 Engine Foot Assembly 122-123
 Engine Control Assembly 124-125
 Injection Pump Assembly 126-127
 Electrical Parts Assembly 128-129
 Feed Pump Assembly 130-131
 Nozzle Assembly 132-133
 Oil Filter Assembly 134-135
 Fuel Filter Assembly 136-137
 Accessories 138-139
 Terms and Condition of Sale — Parts 140

MQ POWER DCA-40SSAI AC GENERATOR

Generator Assembly 66-69
 Control Box Assembly 70-71
 Engine & Radiator Assembly 72-75
 Engine Operating Panel Assembly 76-79
 Battery Assembly 80-81
 Muffler Assembly 82-83
 Fuel Tank Assembly 84-85
 Enclosure Assembly 86-91
 Name Plate And Decals 92-93

NOTE

*Specification and part number
are subject to change without
notice.*

- Dealer account number
- Dealer name and address
- Shipping address (if different than billing address)
- Return fax number
- Applicable model number
- Quantity, part number and description of each part
- Specify preferred method of shipment:
 - UPS Ground
 - UPS Second Day or Third Day*
 - UPS Next Day*
 - Federal Express Priority One (please provide us with your Federal Express account number)*
 - Airborne Express*
 - Truck or parcel post

**Normally shipped the same day the order is received, if prior to 2PM west coast time.*

Earn Extra Discounts when you order by FAX!

All parts orders which include complete part numbers and are received by fax qualify for the following extra discounts:

<u>Number of line items ordered</u>	<u>Additional Discount</u>
1-9 items	3%
10+ items**	5%

Get special freight allowances when you order 10 or more line items via FAX!**

- UPS Ground Service at no charge for freight
- PS Third Day Service at one-half of actual freight cost

No other allowances on freight shipped by any other carrier.

**Common nuts, bolts and washers (all items under \$1.00 list price) do not count towards the 10+ line items.

DISCOUNTS ARE SUBJECT TO CHANGE

Fax order discount and UPS special programs revised June 1, 1995

**Extra Fax Discount
for Domestic USA
Dealers Only**

**Up to 5%
extra savings!**

**UPS
Special**
For faxed orders only

**Now! Direct TOLL-FREE access
to our Parts Department!**

Toll-free nationwide:

800-421-1244

Toll-free FAX:

800/6-PARTS-7 • 800-672-7877

CAUTION:



Failure to follow instructions in this manual may lead to serious injury or even death! This equipment is to be operated by trained and qualified personnel only! This equipment is for industrial use only.

The following safety guidelines should always be used when operating the DCA-40SSAI portable generator:

GENERAL SAFETY

- **DO NOT** operate or service this equipment before reading this entire manual.



- This equipment should not be operated by persons under 18 years of age.



- **NEVER** operate this equipment without proper protective clothing, shatterproof glasses, steel-toed boots and other protective devices required by the job.

- **NEVER** operate this equipment when not feeling well due to fatigue, illness or taking medicine.



- **NEVER** operate this equipment under the influence of drugs or alcohol.



- **NEVER** use accessories or attachments, which are not recommended by MQ Power for this equipment. Damage to the equipment and/or injury to user may result.

- Manufacturer does not assume responsibility for any accident due to equipment modifications.

- Whenever necessary, replace nameplate, operation and safety decals when they become difficult read.

- Always check the machine for loosened threads or bolts before starting.

- **NEVER** touch the hot exhaust manifold, muffler or cylinder. Allow these parts to cool before servicing engine or generator.



- **High Temperatures** – Allow the engine to cool before adding fuel or performing service and maintenance functions. Contact with *hot* components can cause serious burns.

- The engine of this generator requires an adequate free flow of cooling air. Never operate the generator in any enclosed or narrow area where free flow of the air is restricted. If the air flow is restricted it will cause serious damage to the generator or engine and may cause injury to people. The generator engine gives off **DEADLY** carbon monoxide gas.

CAUTION:



- Always refuel in a well-ventilated area, away from sparks and open flames.

- Always use extreme caution when working with **flammable** liquids. When refueling, **stop the engine** and allow it to cool. **DO NOT** smoke around or near the machine. Fire or explosion could result from fuel vapors, or if fuel is spilled on a hot engine.



- **NEVER** operate the generator in an explosive atmosphere or near combustible materials. An explosion or fire could result causing severe *bodily harm or even death*.

- Topping-off to filler port is dangerous, as it tends to spill fuel.

RULES FOR SAFE OPERATION

CAUTION:

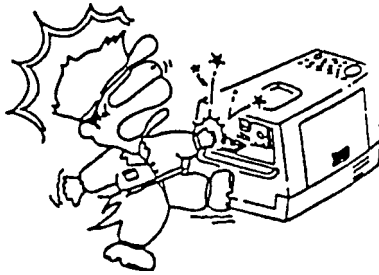

■ **NEVER** touch output terminals during operation. This is extremely dangerous. Always stop the machine when contact with the output terminals is required.

CAUTION:

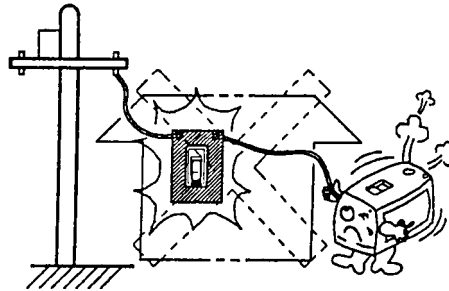

■ **Backfeed to a utility system can cause electrocution and/or property damage. Do not connect to any building's electrical system except through an approved device or after building main switch is opened.**

CAUTION:



Never use damaged or worn cables when connecting power tools or equipment to the generator. Make sure power connecting cables are securely connected to the generator's output terminals, insufficient tightening of the terminal connections may cause damage to the generator and electrical shock.

CAUTION:



DO NOT touch or open any of the below mentioned components while the generator is running. Always allow sufficient time for the engine and generator to cool before performing maintenance.

Radiator

1. **Radiator Cap** - Removing the radiator cap while the engine is hot will result in high pressurized, boiling water to gush out of the radiator, causing severe scalding to any persons in the general area of the generator.
2. **Coolant Drain Plug** - Removing the coolant drain plug while the engine is hot will result in hot coolant to gush out of the coolant drain plug, therefore causing severe scalding to any persons in the general area of the generator.
3. **Engine Oil Drain Plug** - Removing the engine oil drain plug while the engine is hot will result in hot oil to gush out of the oil drain plug, therefore causing severe scalding to any persons in the general area of the generator.

Battery

CAUTION:



Never over fill the battery with water above the upper limit.

The battery contains acids that can cause injury to the eyes and skin. To avoid eye irritation, always wear safety glasses. Use well insulated gloves when picking up the battery. Use the following guidelines when handling the battery:

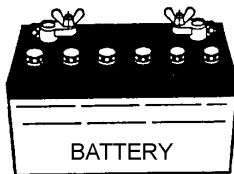

1. **DO NOT** drop the battery. There is the possibility of risk that the battery may explode.
 2. **DO NOT** expose the battery to open flames, sparks, cigarettes etc. The battery contains combustible gases and liquids. If these gases and liquids come in contact with a flame or spark, an explosion could occur.
 3. Always keep the battery charged. If the battery is not charged a buildup of combustible gas will occur.
 4. Always keep battery charging and booster cables in good working condition. Repair or replace all worn cables.
 5. Always recharge the battery in an open air environment, to avoid risk of a dangerous concentration of combustible gases.
 6. In case the battery liquid (dilute sulfuric acid) comes in contact with **clothing or skin**, rinse skin or clothing immediately with plenty of water.
 7. In case the battery liquid (dilute sulfuric acid) comes in contact with your **eyes**, rinse eyes immediately with plenty of water, then contact the nearest doctor or hospital, and seek medical attention.
- **NEVER** Run engine without air filter. Severe engine damage may occur.
 - Always service air cleaner frequently to prevent carburetor malfunction.
 - Always disconnect the battery before performing service on the generator.
 - Always be sure the operator is familiar with proper safety precautions and operations techniques before using generator.
 - Always store equipment properly when not in use. Equipment should be stored in a clean, dry location out of the reach of children.
 - **DO NOT** leave the generator running in the manual mode unattended.
 - **DO NOT** allow unauthorized people to operate this equipment.
 - Always read, understand, and follow procedures in Operator's Manual before attempting to operate equipment.
 - Refer to the **Isuzu Engine Owner's Manual** for engine technical questions or information.

Loading and Unloading (Crane)

- Before lifting, make sure the generator's lifting hook is secure and that there is no apparent damage to the generator itself (loose screws, nuts and bolts). If any part is loose or damaged, please take corrective action before lifting.
- Always drain fuel prior to lifting.
- Always make sure crane or lifting device has been properly secured to the hook of guard frame on generator.
- **NEVER** lift the machine while the engine is running.
- Use adequate lifting cable (wire or rope) of sufficient strength.
- When lifting the generator, always use the balanced center-point suspension hook and lift straight upwards.
- **NEVER** allow any person or animal to stand underneath the machine while lifting.
- When loading the generator on a truck, be sure to use the front and back frame bars as a means to secure the generator during transport.

Transporting

- Always shutdown engine before transporting.
- Tighten fuel tank cap securely.
- Drain fuel when transporting generator over long distances or bad roads.
- Always tie-down the generator during transportation by securing the generator.
- If generator is mounted on a trailer, make sure trailer complies with all local and state safety transportation laws. See page 10 for basic towing procedures.

Emergencies

- Always know the location of the nearest **fire extinguisher** and **first aid kit**. Know the location of the nearest telephone. Also know the phone numbers of the nearest **ambulance**, **doctor** and **fire department**.

Maintenance Safety

- **NEVER** lubricate components or attempt service on a running machine.
- Always allow the machine a proper amount of time to cool before servicing.
- Keep the machinery in proper running condition.
- Fix damage to the machine immediately and always replace broken parts.
- Dispose of hazardous waste properly. Examples of potentially hazardous waste are used motor oil, coolant, fuel, and fuel filters.
- **DO NOT** use plastic containers to dispose of hazardous waste.
- **DO NOT** pour waste, oil, coolant or fuel directly onto the ground, down a drain or into any water source.

Towing Safety Precautions

CAUTION :



Check with your county or state safety towing regulations department before towing your generator.

To reduce the possibility of an accident while transporting the generator on public roads, always make sure the trailer (Figure 1) that supports the generator and the towing vehicle are in good operating condition and both units are mechanically sound.

The following list of suggestions should be used when towing your generator:

- Make sure the hitch and coupling of the towing vehicle are rated equal to, or greater than the trailer "gross vehicle weight rating" (GVWR).
- **ALWAYS** inspect the hitch and coupling for wear. **NEVER** tow a trailer with defective hitches, couplings, chains etc.
- Check the tire air pressure on both towing vehicle and trailer. Also check the tire tread wear on both vehicles.
- **ALWAYS** make sure the trailer is equipped with a "Safety Chain".
- **ALWAYS** attach trailer's safety chain to bumper of towing vehicle.
- **ALWAYS** make sure the vehicle and trailer directional, backup, brake, and trailer lights are connected and working properly.
- The maximum speed for highway towing is **45 MPH** unless posted otherwise. Recommended off-road towing is not to exceed **10 MPH** or less depending on type of terrain.
- Place *chocked blocks* underneath wheel to prevent **rolling**, while parked.
- Place *support blocks* underneath the trailer's bumper to prevent **tipping**, while parked.
- Use the trailer's hand winch to adjust the height of the trailer, then insert locking pin to lock wheel stand in place, while parked.
- Avoid sudden stops and starts. This can cause skidding, or jackknifing. Smooth, gradual starts and stops will improve gas mileage.
- Avoid sharp turns to prevent rolling.
- Remove wheel stand when transporting.
- **DO NOT** transport generator with fuel in tank.

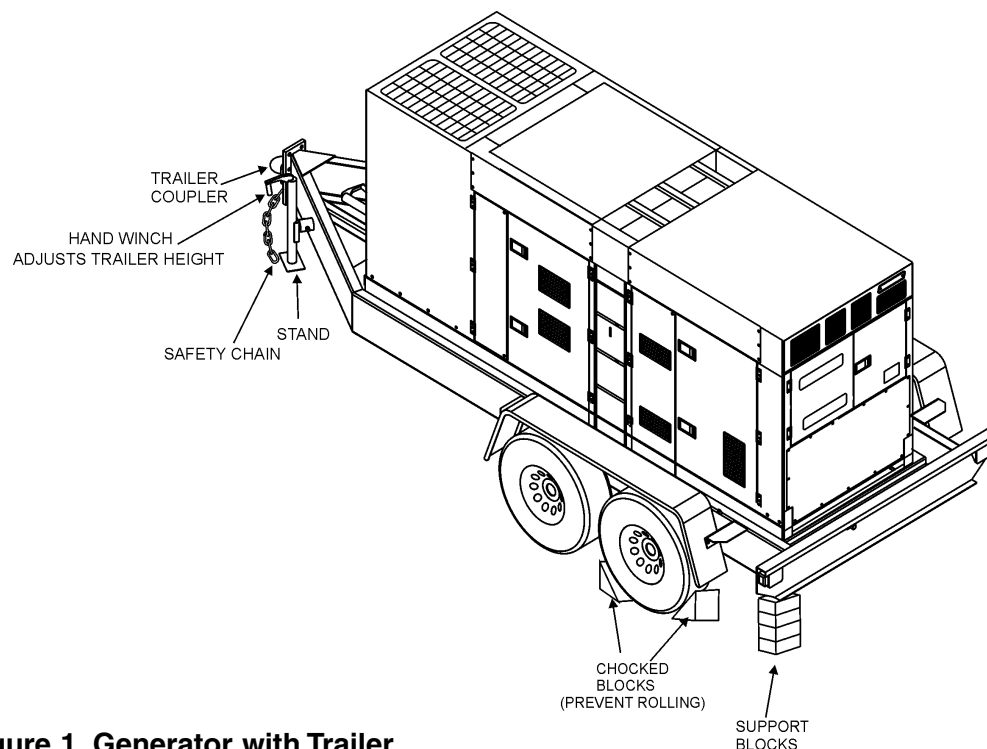

Figure 1. Generator with Trailer

CAUTION:



ALWAYS make sure the trailer is in good operating condition. Check the tires for proper inflation and wear. Also check the wheel lug nuts for proper tightness.

Explanation of Chart:

This section is to provide the user with trailer service and maintenance information. The service and maintenance guidelines referenced in this section apply a wide range of trailers. Remember periodic inspection of the trailer will ensure safe towing of the equipment and will prevent damage to the equipment and personal injury.

It is the purpose of this section to cover the major maintenance components of the trailer. The following trailer components will be discussed in this section:

- Brakes
- Tires
- Lug Nut Torquing
- Suspension
- Electrical
- Brake Troubleshooting Tables

Use the following definitions with reading Table 1.

1. **Fuel Cell** - Provides an adequate amount of fuel for the equipment in use. Fuel cells must be empty when transporting equipment.
2. **Braking System** - System employed in stopping the trailer. Typical braking systems are electric, surge, hydraulic, hydraulic-surge and air.
3. **GVWR**- Gross Vehicle Weight Rating (GVWR), is the maximum number of pounds the trailer can carry, including the fuel cell (empty).
4. **Frame Length** - This measurement is from the ball hitch to the rear bumper (reflector).
5. **Frame Width** - This measurement is from fender to fender.
6. **Jack Stand** - Trailer support device with maximum pound requirement from the tongue of the trailer.
7. **Coupler** - Type of hitch used on the trailer for towing.
8. **Tire Size** - Indicates the diameter of the tire in inches (10,12,14, etc.), and the width in millimeters (175,185,205, etc.). The tire diameter must match the diameter of the tire rim.
9. **Tire Ply** - The tire ply (layers) number is rated in letters; 2-ply,4-ply,6-ply, etc.
10. **Wheel Hub** - The wheel hub is connected to the trailer's axle.
11. **Tire Rim** - Tires mounted on a tire rim. The tire rim must match the size of the tire.
12. **Lug Nuts** - Used to secure the wheel to the wheel hub. Always use a torque wrench to tighten down the lug nuts. See Table 4 and Figure 5 or lug nut tightening and sequence.
13. **Axle** - Indicates the maximum weight the axle can support in pounds, and the diameter of the axle expressed in inches (see Table 3). Please note that some trailers have a double axle. This will be shown as 2-6000 lbs., meaning two axles with a total weight capacity of 6000 pounds.
14. **Suspension** - Protects the trailer chassis from shocks transmitted through the wheels. Types of suspension used are leaf, Q-flex, and air ride.
15. **Electrical** - Electrical connectors (looms) are provided with the trailer so the brake lights and turn signals can be connected to the towing vehicle.
16. **Application** - Indicates which units can be employed on a particular trailer.

DCA-40SSAI —TRAILER-SPECIFICATIONS

Table 1. Specifications

MODEL	APPLICATION	FUEL CELL	BRAKE SYSTEM	GVWR	FRAME LENGTH	FRAME WIDTH	JACK STAND
TRLR-10W	SDW225, SGW250,TLW300	NO	NO	1900LBS	96"	50"	800LB. FULL TILT WHEEL
TRLR-10	DCA10, TLG12, DCA-15	NO	NO	1900LBS	96"	50"	800LB. FULL TILT WHEEL
TRLR-10XF	DCA10, TLG-12, DCA15, TLW-300	52 GAL	NO	1900LBS	96"	50"	800LB. FULL TILT WHEEL
TRLR-225W	WELDERS, DA7000SS	NO	NO	2200LBS	85"	42"	800LB. FULL TILT WHEEL
TRLR-BLW400	BLW-400	NO	ELECTRIC	2700LBS	W/MAST 154" W/O 124"	55" (78" TALL)	800LB. FULL TILT WHEEL
TRLR-50X	DCA-25	NO	NO	2700LBS	124"	55"	800LB. FULL TILT WHEEL
TRLR-50XF	DCA-25	41 GAL	NO	2700LBS	124"	55"	800LB. FULL TILT WHEEL
TRLR-70W	DCA-45, -60, 70	NO	SURGE	7000LBS	186"	77"	2000LB. FLAT PAD
TRLR-70X	DCA-45, -60, 70	OPT	SURGE	7000LBS	138"	66"	2000LB. FLAT PAD
TRLR-70XF	DCA-45, -60, 70	53 GAL	SURGE	7000LBS	138"	66"	2000LB. FLAT PAD
TRLR-100XF	DCA-100, 125	150 GAL	HYDRAULIC SURGE	7000LBS	190"	76"	2000LB. FLAT PAD
TRLR-85/125	DCA-85, 100, 125	145 GAL	HYDRAULIC	10000LBS	186"	77"	2000LB. FLAT PAD
TRLR-150XF	DCA-150, 180	200 GAL	HYDRAULIC SURGE	11160LBS	204"	84"	5000 LB. FLAT PAD
TRLR-220XF	DCA-220	250 GAL	HYDRAULIC SURGE	14000LBS	222"	83"	5000 LB. FLAT PAD
TRLR-300XF	DCA-300	250 GAL	HYDRAULIC SURGE	18000LBS	238"	83"	5000 LB. FLAT PAD
TRLR-400XF	DCA-400	350 GAL	ELECTRIC	18000LBS	238"	83"	5000 LB. FLAT PAD
TRLR-600XF	DCA-600, 800	550 GAL	AIR	30000LBS	384"	96"	5000 LB. FLAT PAD
TRLR-800SX	DCA-600, 800	550 GAL	AIR	30000LBS	384"	96"	5000 LB. FLAT PAD

DCA-40SSAI —TRAILER-SPECIFICATIONS

Table 1. Specifications (Con't)

MODEL	COUPLER	TIRES	WHEELS	AXLE	HUBS	SUSPENSION	ELECTRICAL
TRLR-10W	2" BALL CLASS 2 ADJUSTABLE	175-13C	13"X4.50"	2200# 2X2	5 LUG	3 LEAF	4 WIRE LOOM W/ 4 POLE FLAT
TRLR-10	2" BALL CLASS 2 ADJUSTABLE	175-13C	13"X4.5"	2200#2X2	5 LUG	3 LEAF	4 POLE FLAT
TRLR-10XF	2" BALL CLASS 2 ADJUSTABLE	175-13C	13"X4.5"	2200#2X2	5 LUG	3 LEAF	4 POLE FLAT
TRLR-225W	2" BALL CLASS 2 ADJUSTABLE	175-13B	13X4.5"	2200#2X2	5 LUG	Q FLEX	4 POLE FLAT
TRLR-BLW 400	2" BALL CLASS 2 ADJUSTABLE	175-13C	13 X 4.5"	2200#2X2	5 LUG	3 LEAF	4 POLE FLAT
TRLR-50X	2" BALL CLASS	B78-13LRC	13"X4.50"	3500lbs. 2-3/8"	5 LUG	4 LEAF	4 POLE RUBBER FLAT
TRLR-50XF	2" BALL CLASS	B78-13LRC	13"X4.50"	3500lbs. 2-3/8"	5 LUG	4 LEAF	4 POLE RUBBER FLAT
TRLR-70W	2" BALL CLASS 3" ADJUSTABLE	205-14C BIAS (4)	14"X5"	3500lbs. 3"	5 LUG	5 LEAF	4 POLE RUBBER FLAT
TRLR-70X	2" BALL CLASS 3" ADJUSTABLE	205-14C BIAS (4)	14"X5"	3500lbs 3"	5 LUG	5 LEAF	4 POLE RUBBER FLAT
TRLR-70XF	2" BALL CLASS 3" ADJUSTABLE	205-14C BIAS (4)	14"X5"	3500lbs. 3"	5 LUG	5 LEAF	4 POLE RUBBER FLAT
TRLR-100XF	ADJUSTABLE 2-5/6 OPT 3" EYE	205-15C BIAS (4)	14"X5.5"	3500lbs 3"	5 LUG	5 LEAF	4 WIRE LOOM
TRLR-85/125	ADJUSTABLE 2-5/6 OPT 3" EYE	ST225/75R15D RADIAL (4)	14"x6"	(2)-6000lbs	6 LUG	7 LEAF	4 WIRE LOOM
TRLR-150XF	3" BALL EYE	750-16 E BIAS (4)	16"X7"	(2)-6000lbs	8 LUG	7 LEAF	4 WIRE LOOM
TRLR-220XF	3" EYE ADJUSTABLE	ST235/85R16E RADIAL(4)	16"X7"	(2)-7000lbs	8 LUG	Q FLEX	4 WIRE LOOM
TRLR-300XF	3" EYE ADJUSTABLE	ST235/85R16E RADIAL(6)	16"X7"	(2)-6000lbs	8 LUG	Q FLEX	4 WIRE LOOM
TRLR-400XF	3" EYE ADJUSTABLE	ST235/85R16E RADIAL(6)	16"X7"	(3)-7000lbs.	8 LUG	Q FLEX	4 WIRE LOOM
TRLR-600XF	5TH WHEEL	ST215/75R17.5H RADIAL (8)	16"X7"	(3)-10000lbs	8 LUG	7 LEAF	6 WIRE LOOM
TRLR-800AR	5TH WHEEL	ST215/75R17.5H RADIAL (8)	16"X7"	(3)-10000lbs	8 LUG	AIR-RIDE	6 WIRE LOOM

Brakes

If your trailer has a braking system, the brakes should be inspected the first 200 miles of operation. This will allow the brake shoes and drums to seat properly. After the first 200 mile interval, inspect the brakes every 3,000 miles. If driving over rough terrain, inspect the brakes more frequently.

Electric Brakes

Electrically actuated brakes (Figure 2) are similar to hydraulic brakes. The basic difference is that hydraulic brakes are actuated by an electromagnet.

Listed below are some of the advantages that electric brakes have over hydraulic brakes:

- Brake system can be manually adjusted to provide the corrected braking capability for varying road and load conditions
- Brake system can be modulated to provide more or less braking force, thus easing the brake load on the towing vehicle
- Brake system has very little lag time between the time the vehicle's brakes are actuated and the trailer's brakes are actuated
- Brake system can provide an independent emergency brake system

Remember in order to properly synchronize the tow vehicle's braking to the trailer's braking, can only be accomplished by road testing. Brake lockup, grabbiness or harshness is due to lack of synchronization between the tow vehicle and the trailer being towed or under-adjusted brakes.

Before any brake synchronizations adjustments can be made, the trailer brakes should be burnished-in by applying the brakes 20-30 times with approximately a 20 m.p.h. decrease in speed, e.g. 40 m.p.h. to 20 m.p.h. Allow ample time for brakes to cool between application. This allows the brake shoes to slightly be seated into the brake drum surface.

Figure 2 displays the major electric brake components that will require inspection and maintenance. Please inspect these components as required.

Electric Brake Adjustment

1. Place the trailer on jack stands. Make sure the jack stands are placed on secure level ground.
2. Check the wheel and drum for free rotation.
3. Remove the adjusting hole cover from the adjusting slot at the bottom brake backing plate.
4. With a screwdriver or standard adjusting tool, rotate the star wheel of the adjuster assembly to expand the brake shoes.
5. Adjust the brake shoes outward until the pressure of the lining against the wheel drum makes the wheel difficult to turn.
6. Rotate the star wheel in the opposite direction until the wheel rotates freely with slight lining drag.
7. Replace the adjusting hole cover and lower the trailer to the ground.
8. Repeat steps 1 through 6 on the remaining brakes.

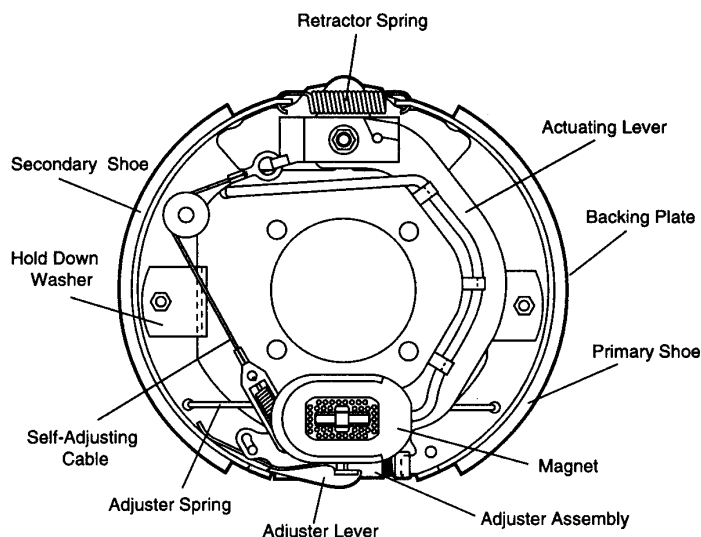

Figure 2. Electrical Brake Components

Hydraulic/Air/Surge Brakes

Hydraulic brakes (Figure 3) should not require any special attention with the exception of routine maintenance such as shoe and lining replacement. These brakes can be adjusted in the same manner as electric brakes. Brake lines should be periodically checked for cracks, kinks, or blockage.

Figure 3 below displays the major hydraulic/air/surge brake components that will require inspection and maintenance. Please inspect these components as required using steps 1 through 6 as referenced in the electric brake adjustments section.

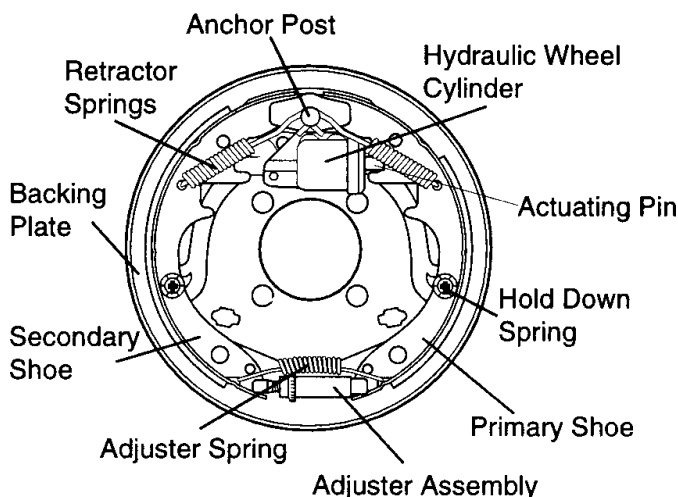

Figure 3. Hydraulic Brake Components

Tires/Wheels/Lug Nuts

Tires and wheels are a very important and critical components of the trailer. When specifying or replacing the trailer wheels it is important the wheels, tires, and axle are properly matched.

CAUTION:



DO NOT attempt to repair or modify a wheel. DO NOT install in inner tube to correct a leak through the rim. If the rim is cracked, the air pressure in the inner tube

may cause pieces of the rim to explode (break off) with great force and cause serious eye or bodily injury.

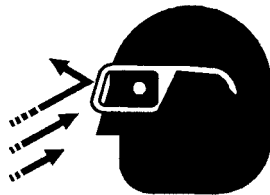

Tire Wear/Inflation

Tire inflation pressure is the most important factor in tire life. Pressure should be checked cold before operation DO NOT bleed air from tires when they are hot. Check inflation pressure weekly during use to insure the maximum tire life and tread wear.

Table 2 (Tire Wear Troubleshooting) will help pinpoint the causes and solutions of tire wear problems.

CAUTION:

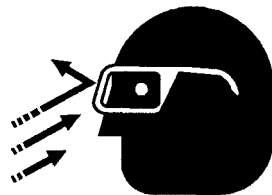

NOTE

ALWAYS wear safety glasses when removing or installing force fitted parts. Failure to comply may result in serious injury.

TABLE 2. TIRE WEAR TROUBLESHOOTING

WEAR PATTERN		CAUSE	SOLUTION
	Center Wear	Over Inflation.	Adjust pressure to particular load per tire manufacturer.
	Edge Wear	Under Inflation.	Adjust pressure to particular load per tire manufacturer.
	Side Wear	Loss of camber or overloading.	Make sure load does not exceed axle rating. Align wheels.
	Toe Wear	Incorrect toe-in.	Align wheels.
	Cupping	Out-of-balance.	Check bearing adjustment and balance tires.
	Flat Spots	Wheel lockup & tire skidding.	Avoid sudden stops when possible and adjust brakes.

Suspension

The leaf suspension springs and associated components (Figure 4) should be visually inspected every 6,000 miles for signs of excessive wear, elongation of bolt holes, and loosening of fasteners. Replace all damaged parts (suspension) immediately. Torqued suspension components as detailed in Table 3.

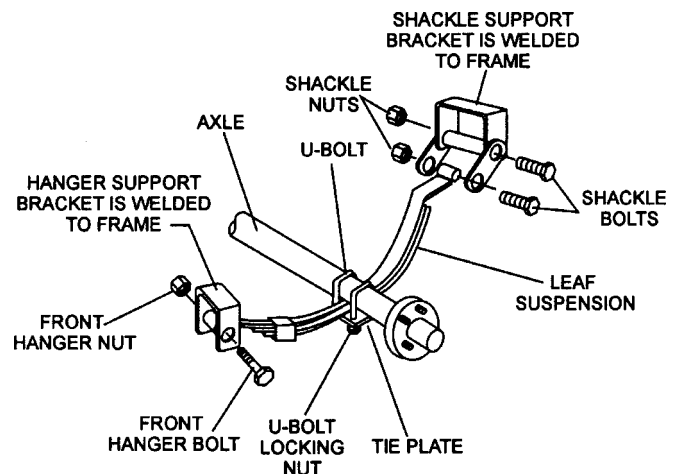

Figure 4. Major Suspension Components

Table 3. Suspension Torque Requirements

Item	Torque (Ft.-Lbs.)
3/8" U-BOLT	MIN-30 MAX-35
7/16" U-BOLT	MIN-45 MAX-60
1/2" U-BOLT	MIN-45 MAX-60
SHACKLE BOLT SPRING EYE BOLT	SNUG FIT ONLY. PARTS MUST ROTATE FREELY. LOCKING NUTS OR COTTER PINS ARE PROVIDED TO RETAIN NUT-BOLT ASSEMBLY.
SHOULDER TYPE SHACKLE BOLT	MIN-30 MAX-50

Lug Nut Torque Requirements

It is extremely important to apply and maintain proper wheel mounting torque on the trailer. Be sure to use only the fasteners matched to the cone angle of the wheel. Proper procedure for attachment of the wheels is as follows:

1. Start all wheel lug nuts by hand.
2. Torque all lug nuts in sequence. See Figure 5. DO NOT torque the wheel lug nuts all the way down. Tighten each lug nut in 3 separate passes as defined by Table 4.
3. After first road use, retorque all lug nuts in sequence. Check all wheel lug nuts periodically.

Table 4. Tire Torque Requirements

Wheel Size	First Pass FT-LBS	Second Pass FT-LBS	Third Pass FT-LBS
12"	20-25	35-40	50-65
13"	20-25	35-40	50-65
14"	20-25	50-60	90-120
15"	20-25	50-60	90-120
16"	20-25	50-60	90-120

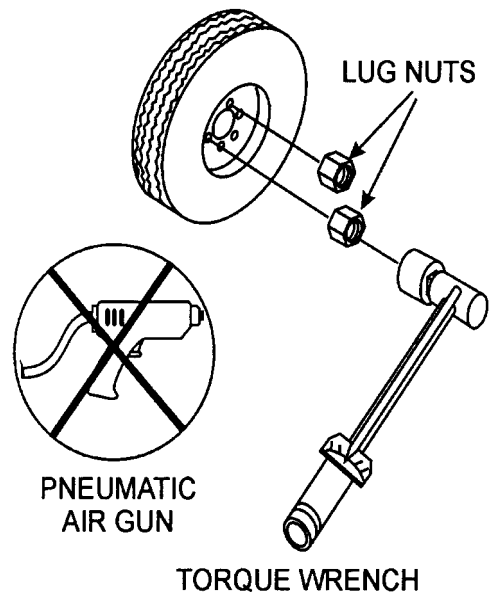
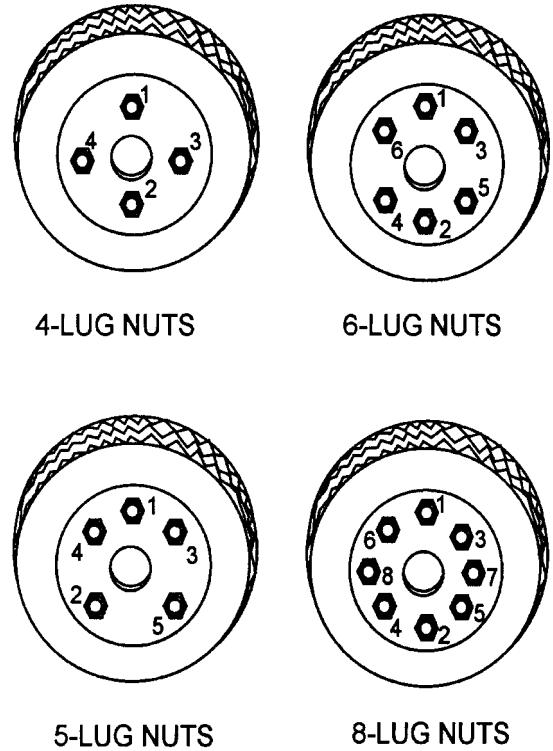

Figure 5. Wheel Lug Nuts Tightening Sequence

NOTE

NEVER use an pneumatic air gun to tighten wheel lug nuts.

DCA-40SSAI —TRAILER-WIRING DIAGRAM

TRAILER SIDE

TOWING VEHICLE SIDE

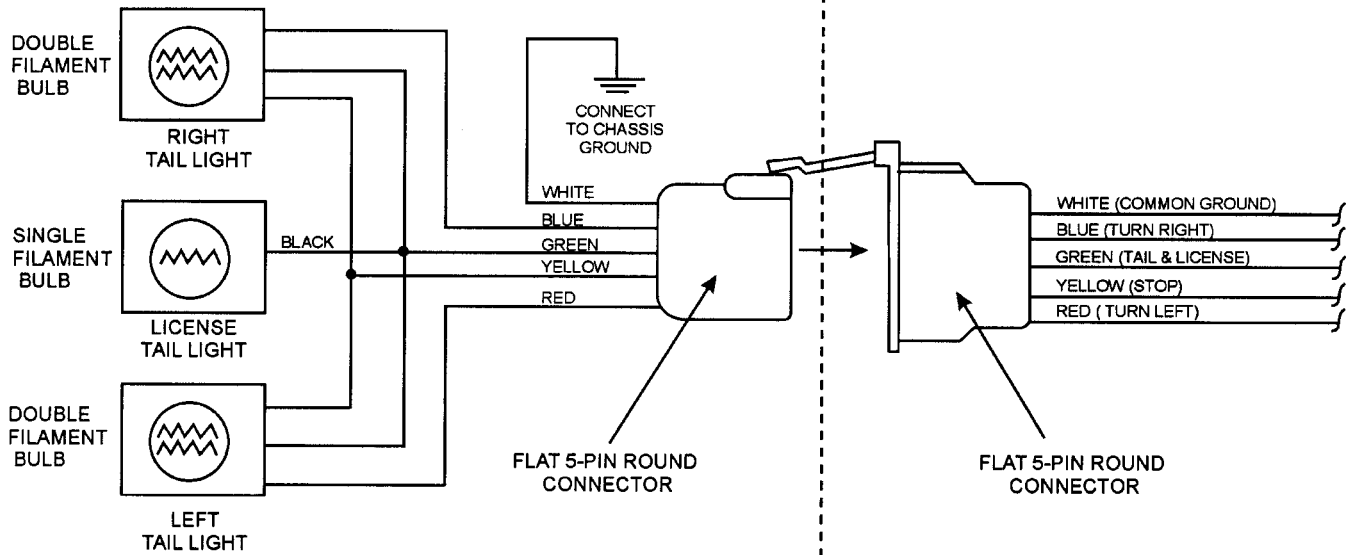
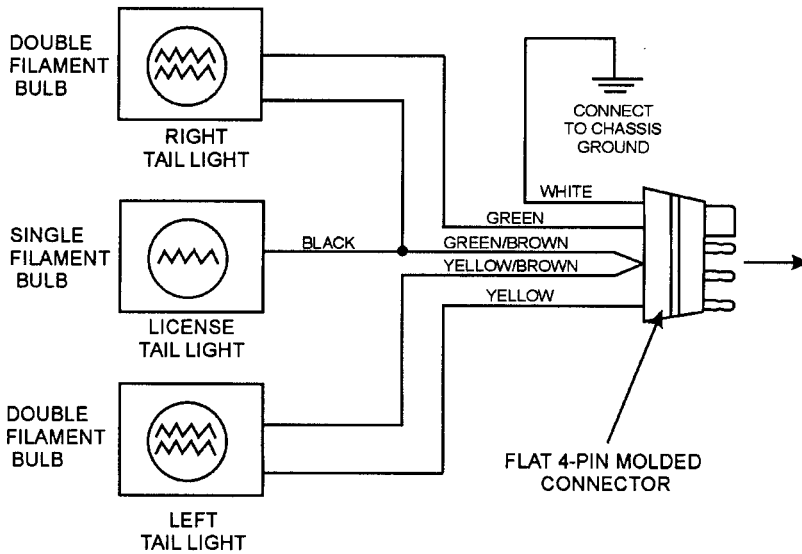

Table 5. Electric Brake Troubleshooting

Symptom	Possible Cause	Solution
No Brakes or Intermittent Brakes	Any open circuits or broken wires?	Find and correct.
	Any short circuits?	Find and correct.
	Faulty controller?	Test and correct.
	Any loose connections?	Find and repair.
	Ground wire secure?	Find and secure.
Weak Brakes or Brakes Pull to One Side	Grease or oil on magnets or linings?	Clean or replace.
	Connections corroded?	Clean and correct cause of corrosion.
	Brake drums scored or grooved?	Machine or replace.
	Brakes synchronized?	Correct.
Locking Brakes	Brake components loose, bent or broken?	Replace components.
	Brake drums out-of-round?	Replace.
Noisy Brakes	System lubricated?	Lubricate.
	Brake components correct?	Replace and correct.
Dragging Brakes	Bearings of the wheel adjusted?	Adjust.

Table 6. Hydraulic Brake Troubleshooting

Symptom	Possible Cause	Solution
No Brakes	Brake line broken or kinked?	Repair or replace.
Weak Brakes or Brakes Pull to One Side	Brake lining glazed?	Reburnish or replace.
	Trailer overloaded?	Correct weight.
	Brake drums scored or grooved?	Machine or replace.
	Tire pressure correct?	Inflate all tires equally.
	Tires unmatched on the same axle?	Match tires.
Locking Brakes	Brake components loose, bent or broken?	Replace components.
	Brake drums out-of-round?	Replace.
Noisy Brakes	System lubricated?	Lubricate.
	Brake components correct?	Replace and correct.
Dragging Brakes	Brake lining thickness correct or in right wrong position?	Install new shoes and linings.
	Enough brake fluid or correct fluid?	Replace rubber parts fill with dot4 fluid.

DCA-40SSAI — GENERATOR DECALS

The DCA-40SSAI generator is equipped with a number of safety decals. These decals are provided for operator safety and maintenance information. The illustration below and on the preceding page show the decals as they appear on the machine. Should any of these decals become unreadable, replacements can be obtained from your dealer.

OPERATING PROCEDURES

Manual Starting

1. Check the engine oil, coolant, and fuel levels. Replenish if necessary.
2. Place all Generator Circuit Breakers in the "OFF" position and close all doors.
3. Check that the Voltage select switch (or the Voltage change-over board) is present at desired voltage.
(In case of generator having multiple voltage ratings)
4. Set the Engine speed switch to the "LOW" position.
5. Turn the Auto-Off/Reset-Manual switch to the "Manual" position to start the engine. If the engine fails to start in the specified number of attempts, the overcrank lamp will indicate and the Auto-Off/Reset-Manual switch must be returned to the "Off/Reset" position before proceeding.
6. When the engine is ready for starting during cold weather operating conditions, push the Intake Heater button for approximately 30 seconds. Start engine using the Auto-Off/Reset-Manual switch to the "Manual" position. As soon as the engine starts, release the button.
If the engine still does not start, utilize the water heater until water is warm. (If additional water heater is supplied)
7. After starting, allow the engine to run for 1 or 2 minutes to warm-up. At temperatures below freezing, this time period must be extended to 2 to 4 minutes.
8. When the engine starts, immediately check for abnormal noise, vibration, fluid leakage or any indication of a problem. Check the control panel gauges. If all is normal, let the engine remain at the "Low" position for a short time, depending on the ambient conditions, warm up.
9. After sufficient warm-up time has elapsed, set the Engine speed switch to the "High" position and the unit is ready for operation.
10. Check the NO-Load speed as shown in the table below.
60Hz operation—Approx. 50 Ohz (1500rpm)
11. Adjust the Voltage Regulator to the specified voltage.

Manual Stopping

1. Place the Generator Circuit Breakers in the "OFF" position.
2. Set the Engine speed switch to the "LOW" position, and allow the unit to cool for a few minutes.
3. Turn the Auto-Off/Reset-Manual switch, to the "Off/Reset" position.

Auto Starting/Stopping

1. With the Auto/Manual switch in the Auto position, the Auto Starting/Stopping controller monitors remote start contacts. Closure of the remote start contacts will begin engine cranking. When the contacts are opened cranking will stop or if running the engine will stop. All functions of the Automatic shutdown System work as in Manual Starting/stopping.
2. For cold weather conditions utilize the water heater until water is warm. If the engine still does not start, please operate as in Manual Starting.

Emergency Stopping

1. Place the Generator Circuit Breakers in the "OFF" position.
2. Turn the Auto-Off/Reset-Manual switch to the "Off/Reset" position.

M35200010

P/N M3552000103

SAFETY INSTRUCTIONS

Improper operation of this machine can cause severe injury or death.

- Read the instruction manual carefully before operating or servicing.

This machine should only be operated by a person with sufficient knowledge and skill to ensure safe operation.

High voltage circuits are located inside the output terminal cover and control panel.

- Close the cover and control panel before operating.

Moving parts and hot surfaces are contained within the enclosure.

- Close all doors and lock them before operating.

M92010030

P/N M9520100304

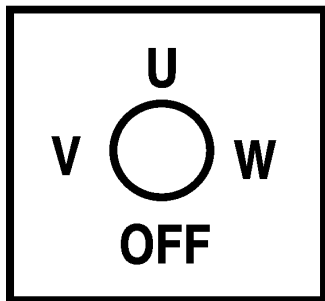

P/N M9520000104

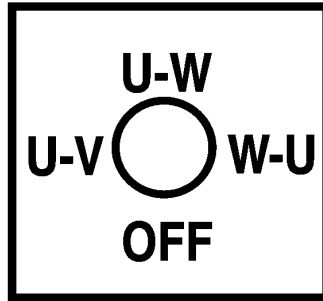

P/N M9520000204



P/N M950000004



P/N M9510200002

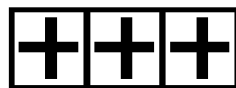

P/N M9500300104

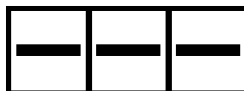

P/N M9500300004

OVER CURRENT RELAY

If it is Impossible to reset the CIRCUIT BREAKER, open the control panel and push the RESET BUTTON as below.

M92020010

P/N M9520200104



P/N M9500500104

DIESEL FUEL

M90050000

P/N M9500500004

WATER • OIL CHECK AND FILL DAILY

M90300010

P/N M9503000103



⚠ WARNING
ELECTRIC SHOCK HAZARD

- Do not touch internal wiring or connections while this machine is operating.
- Turn power off before servicing.

M92010000

P/N M9520100004

DANGER
HIGH VOLTAGE

M92010040

P/N M9520100401

NOTE

To use 50 AMP receptacles, adjust the voltage selector switch to the single phase position and the main line circuit breaker to the on position.

M1500020

P/N M1550000204

	<p>⚠ WARNING ELECTRIC SHOCK HAZARD</p> <ul style="list-style-type: none"> • Do not touch output terminals while this machine is operating. • Turn power off before servicing. 	<p>⚠ WARNING ELECTRIC SHOCK HAZARD</p> <ul style="list-style-type: none"> • Always complete the grounding path from the ground terminal on this genset to an external grounding source. See instruction manual for details. 	<p>⚠ WARNING</p> <ul style="list-style-type: none"> • Before connecting this generator to any building's electrical system, a licensed electrician must install an isolation (transfer) switch. • Serious injury or death may result without this transfer switch.
	M92010050		
	P/N M9520100503		



⚠ WARNING
HOT COOLANT can cause severe burns.

- Do not remove cap if radiator is hot.

M90310000

P/N M9503100004



⚠ WARNING
ENGINE EXHAUST can cause severe injury or death.

- Use only in open, well ventilated areas or vent exhaust outside.

M90320000

P/N M9503200004

⚠ CAUTION
Stop engine before switching.

M92010020

P/N M9520100204



⚠ CAUTION
MOVING PARTS can cause severe injury.

- Do not operate with doors open.
- Stop engine before servicing.

M90300000

P/N M9503000004



⚠ WARNING
HOT PARTS can burn skin.

- Do not touch until the machine has sufficiently cooled.

M91010000

P/N M9510100004



⚠ WARNING
ELECTRIC SHOCK HAZARD

- Do not touch internal wiring or connections while this machine is operating.
- Turn power off before servicing.

M92010000

P/N M9520100004

DCA-40SSAI — SPECIFICATIONS

Table 7. Specifications					
Generator Specifications					
Model	DCA-40SSAI				
Type	Revolving field, self ventilated, open protected type synchronous generator				
Armature Connection	Star with Neutral				
Phase	3				
Standby Output	46.8 KVA (37.4 KW)				
Prime Output	40 KVA (32 KW)				
Voltage	240V or 480V				
Frequency	60 Hz				
Speed	1800 rpm				
Power Factor	0.8				
Aux. AC Power	Single Phase, 60 Hz				
Voltage	120/240 V				
Output	11.5 KW (13.4 KW)				
Engine Specifications					
Model	ISUZU QD100 (4BD1)				
Type	4 Cycle, water-cooled, swirl combustion chamber type				
No. of Cylinders	4 cylinders				
Bore x Stroke	4 in. x 4.6 in. (102 mm x 118 mm)				
Rated Output	52 HP/1800 rpm				
Displacement	235 cu. in. (3856 cc)				
Starting	Electric				
Coolant Capacity	4 gal. (15 liters)				
Lube Oil Capacity	3.4 gal. (12.9 liters)				
Fuel Consumption	<table border="1" style="width: 100%; border-collapse: collapse;"> <tr> <td style="text-align: center;">2.3 gal. (8.7L)/hr at full load</td> <td style="text-align: center;">2.0 gal. (7.6L)/hr at 3/4 load</td> </tr> <tr> <td style="text-align: center;">1.5 gal. (5.7L)/hr at 1/2 load</td> <td style="text-align: center;">1.1 gal. (4.2L)/hr at 1/4 load</td> </tr> </table>	2.3 gal. (8.7L)/hr at full load	2.0 gal. (7.6L)/hr at 3/4 load	1.5 gal. (5.7L)/hr at 1/2 load	1.1 gal. (4.2L)/hr at 1/4 load
2.3 gal. (8.7L)/hr at full load	2.0 gal. (7.6L)/hr at 3/4 load				
1.5 gal. (5.7L)/hr at 1/2 load	1.1 gal. (4.2L)/hr at 1/4 load				
Battery	12V- 100AH x 2				
Fuel	#2 Diesel Fuel				

DCA-40SSAI FAMILIARIZATION

Generator

The MQ Power Model DCA-40SSAI is a 26 kW **generator** that is designed as a high quality portable (requires a trailer for transport) power source for telecom sites, lighting facilities, power tools, submersible pumps and other industrial and construction machinery.

Engine Operating Panel

The "Engine Operating Panel" is provided with the following:

- Tachometer
- Water Temperature Gauge
- Oil Pressure Gauge
- Charging Ammeter Gauge
- Fuel level gauge
- Engine Speed Control
- Pre-Heat Button
- Panel Light
- Panel Light Switch
- Starter /Preheat Switch

Generator Control Panel

The "Generator Control Panel" is provided with the following:

- Output Voltage Adjustment Knob
- Frequency Meter (Hz)
- AC Ammeter (Amps)
- AC Voltmeter (Volts)
- Ammeter Change-Over Switch
- Voltmeter Change-Over Switch
- Voltage Regulator

Output Terminal Panel

The "Output Terminal Panel" is provided with the following:

- Two 120V, 20A receptacles
- Two 240V, 20A receptacles
- One twist-lock 120V, 50A receptacle
- 50A and 30A circuit breakers

Control Box

The "Control Box" is provided with the following:

- Main Circuit Breaker 100 amps
- Over-Current Relay

Open Delta Excitation System

The DCA-40SSAI generator is equipped with the state of the art "**Open-Delta**" excitation system. The open delta system consist of an electrically independent winding wound among stationary windings of the AC output section.

There are four leads: A, B, C and D. During light loads, the power to the **Automatic Voltage Regulator (AVR)** is supplied from the leads parallel connections of B&C. When loads increase, the AVR switches and accepts power from leads A&D. The output of leads A&D increase proportionally with load. This of adding the voltages to each phase provides better voltage response during heavy loads.

The connections of the AVR to the AC output windings are for sensing only. No power is required from these windings.

The open-delta design provides virtually unlimited excitation current, offering maximum motor starting capabilities. The excitation does not have a "**fixed ceiling**" and responds according the demands of the required load.

Engine

The **DCA-40SSAI** is powered by a 4 cycle, water cooled, Isuzu 4BD1 **diesel** engine. This engine is designed to meet every performance requirement for the generator. Reference Table 7, page 23 for engine specifications.

In keeping with Multiquip's policy of constantly improving its products, the specifications quoted herein are subject to change without prior notice.

The basic controls and indicators for the DCA-40SSAI generator are addressed on the following pages.

Mechanical Governor System

The mechanical governor system control the RPM of the engine. When the engine demands increase or decrease, the mechanical governor system regulates the frequency variation to $\pm 1.5\%$. The electronic governor option increases frequency variation to $\pm .25\%$.

DCA-40SSAI — MAJOR COMPONENTS

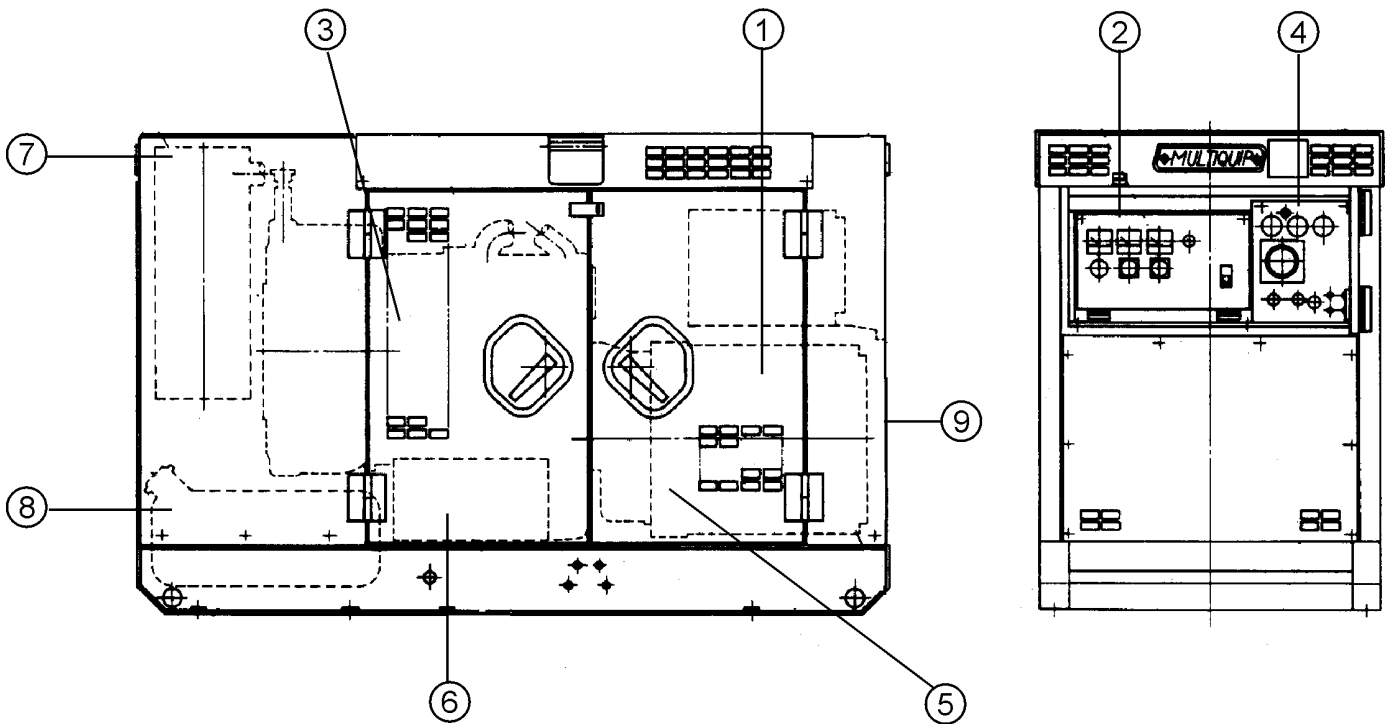

NO	ITEM
1	GENERATOR
2	CONTROL PANEL
3	ENGINE AND RADIATOR
4	ENGINE OPERATING PANEL
5	OUTPUT TERMINAL
6	BATTERY
7	MUFFLER
8	FUEL TANK
9	ENCLOSURE

Figure 6. Major Components

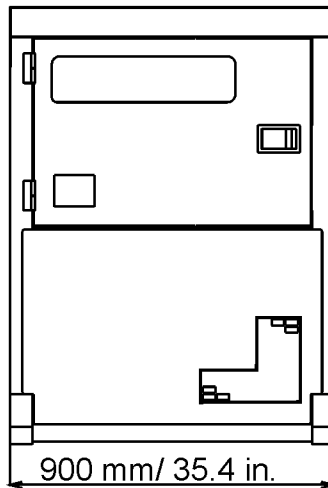
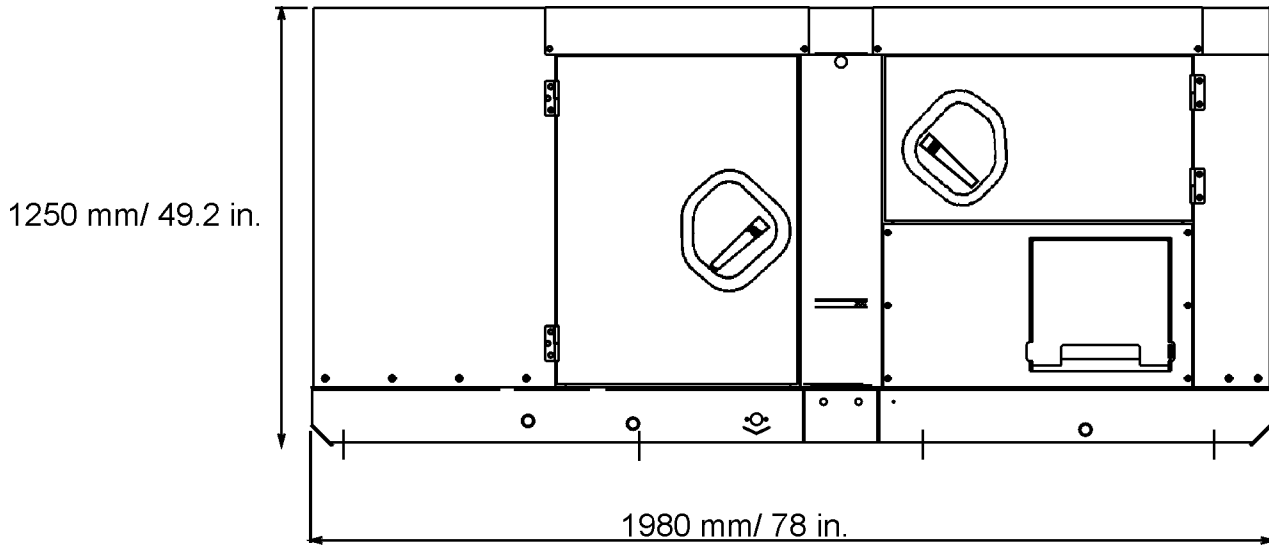

Weight: 2844 lbs (1290kg)

Figure 7. Dimensions

DCA-40SSAI — CONTROL PANEL DESCRIPTION

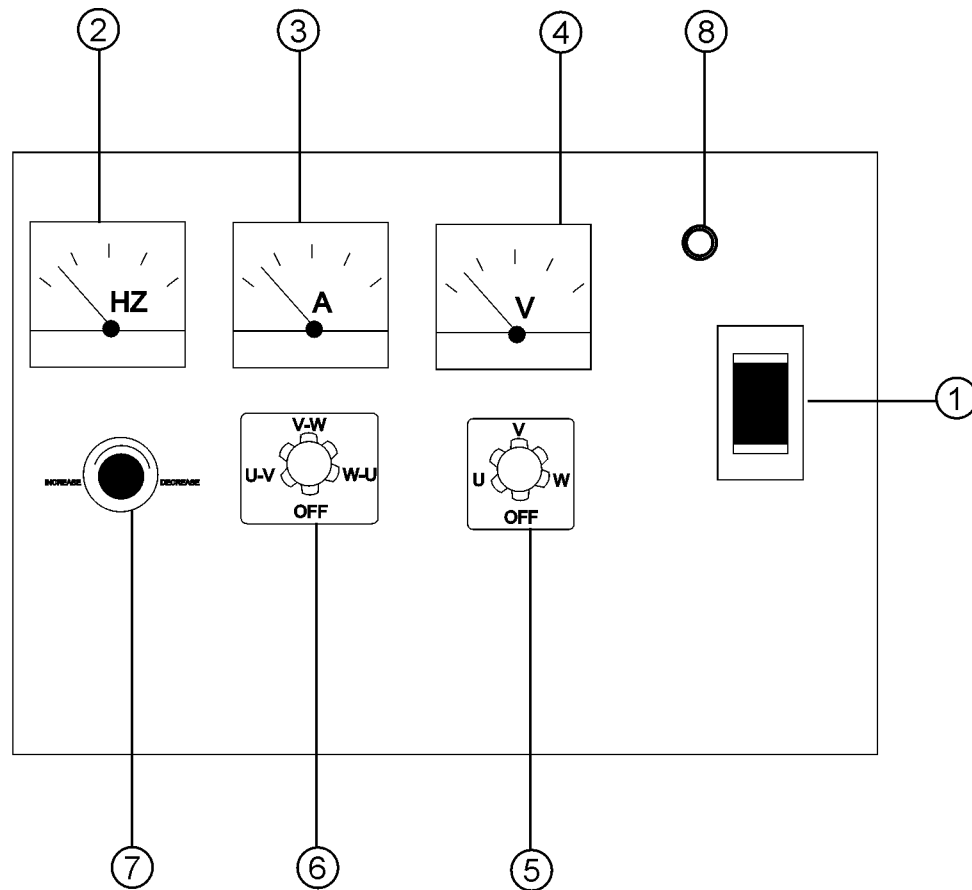

NO	ITEM
1	CIRCUIT BREAKER
2	FREQUENCY METER
3	AC AMMETER
4	AC VOLTMETER
5	VOLTAGE REGULATOR
6	CHANGE-OVER SWITCH, AMMETER
7	CHANGE-OVER SWITCH, VOLTMETER
8	PILOT LAMP

Figure 8. Control Panel

The definitions below describe the controls and functions of the DCA-40SSAI " **Control Panel** " (Figure 8).

1. **Main Circuit Breaker** – This three-pole, 110 amp main breaker is provided to protect the UNV voltage output terminals from overload.
2. **AC Ammeter** – Indicates the amount of current the load is drawing from the generator.
3. **Frequency Meter** – Indicates the output frequency in hertz (Hz). Normally 60 Hz \pm 1 Hz .
4. **AC Voltmeter** – Indicates the single phase output voltage present at the UNV terminals.
5. **Voltage Regulator Control** – Allows manual adjustment of the generator's output voltage.
6. **Ammeter Change-Over Switch** – This switch allows the AC ammeter to indicate the current flowing to the load connected to any phase of the output terminals, or to be switched off.
7. **Voltmeter Change-Over Switch** – This switch allows the AC voltmeter to indicate phase to phase voltage between any two phases of the output terminals or to be switched off.

DCA-40SSAI — ENGINE OPERATING PANEL DESCRIPTION

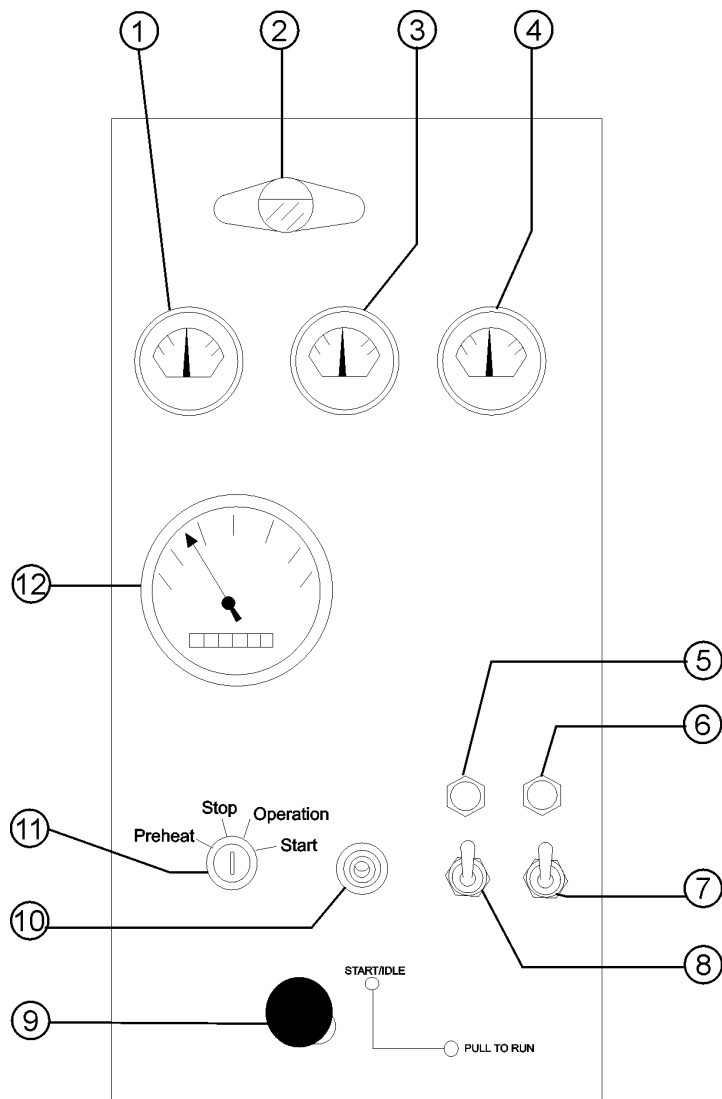

NO	ITEM
1	OIL PRESSURE GAUGE
2	PANEL LIGHT
3	WATER TEMPERATURE GAUGE
4	CHARGING AMMETER GAUGE
5	OIL PRESSURE INDICATOR
6	WATER TEMPERATURE INDICATOR
7	LAMP CHECK SWITCH
8	PANEL LIGHT SWITCH
9	SPEED CONTROL HANDLE
10	PREHEAT LAMP
11	IGNITION SWITCH
12	TACHOMETER

Figure 9. Engine Operating Panel

DCA-40SSAI — ENGINE OPERATING PANEL DESCRIPTION

The definitions below describe the controls and functions of the DCA-40SSAI " **Engine Operating Panel** " (Figure 9).

1. **Fuel Gauge** - Indicates amount of diesel fuel available.
2. **Tachometer** – Indicates engine speed in RPM's for 60 Hz operation. This meter should indicate 1800 RPM's when the rated load is applied. In addition a built in hour meter will record the number of operational hours that the generator has been in use.
3. **Charging Ammeter Gauge** – Indicates the current being supplied by the engine's alternator which provides current for generator's control circuits and battery charging system.
4. **Water Temperature Gauge** – During normal operation this gauge be should read between 165° to 215°.
5. **Oil Pressure Gauge** – Normal operation should be about 25 psi. When starting the generator the oil pressure may read a bit higher, but after the engine warms up the oil pressure should return to normal.

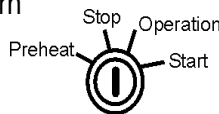

6. **Starter Switch**- Use key to preheat, start and stop engine.
7. **Pre-Heat Button** – Press hold this button until the preheat lamp is lit (ON).
8. **Engine speed Handle**- This handle will change the speed of the engine from high to low.
9. **Panel light switch**- When activated, will turn on control panel light.



10. **Panel light** - Normally used in dark places or at night. When activated, panel will luminate. When the generator is not in use, turn the panel light switch to the 'OFF' position.

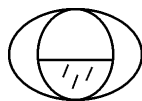

Output Terminal Panel

The output control panel is located on the rear (control panel) end of the generator. The UNV lugs are protected by a face plate cover that can be secured in the close position by a pad lock.

120 Volt Receptacle

One GFCI Duplex NEMA 5-20R (120V, 20 Amp) receptacle is located on the output terminal. This receptacle can be used anytime the generator is in operation. The receptacle is controlled by the circuit breaker located on the control panel.

The reset button will reset the receptacle after being tripped. Pressing the "Test Button" (Figure 8) in the center of this receptacle will check the GFCI function. The receptacle should be tested at least once a month.

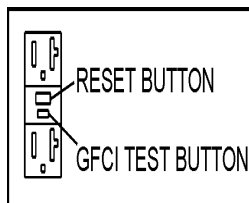

Figure 10. GFCI Test Button

Generator Grounding

Make sure the generator is properly grounded before applying load. Generators are NOT considered grounded when mounted on a trailer.

Twist Lock Dual Voltage Receptacles - To use these receptacles, place the voltage selector switch in the single phase 240/120 voltage position and adjust the output voltage to 240 volts with the voltage regulator on the Control Panel (Figure 8, page 28). Place the voltmeter change-over switch to the U-W position and the ammeter change-over switch to the U or W to read the output.

Connecting Load

Loads can be connected to the generator by the UVWO lugs or the duplex receptacles. (See figure 3). Make sure to read the operation manual before attempting to connect a load to the generator.

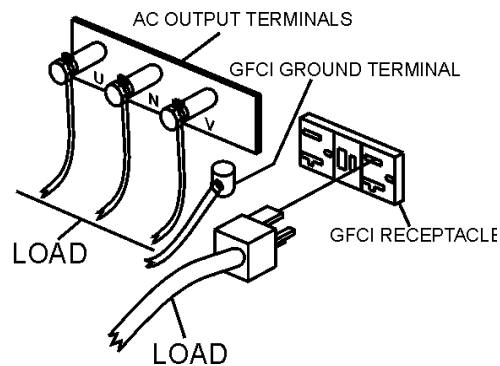

Figure 11. Load Application

Circuit Breakers

To protect the generator from an overload, a 3-pole, 110 amp, **main** circuit breaker is provided to protect the UVWO output terminals from overload. In addition two single-pole, 20 amp **GFCI** circuit breakers are provided to protect the GFCI receptacles from overload. Three 50 amp **load** circuit breakers have also been provided to protect the load side of the generator from overload. Make sure to switch **ALL** circuit breakers to the "OFF" position prior to starting the engine.

Maximum Output

The entire load connected to the UNV Lugs, all four slots in the duplex receptacles, and the must not exceed 37.4 kW in standby or 36 kW in prime output.

Generator Grounding

Make sure to ground the generator in **EVERY** application prior to connecting a load. Generators are **NOT** grounded just because they are mounted on trailers or other vehicles that are on rubber tires. See page X for further details.

DCA-40SSAI — OUTPUT TERMINAL VOLTAGE SELECTION

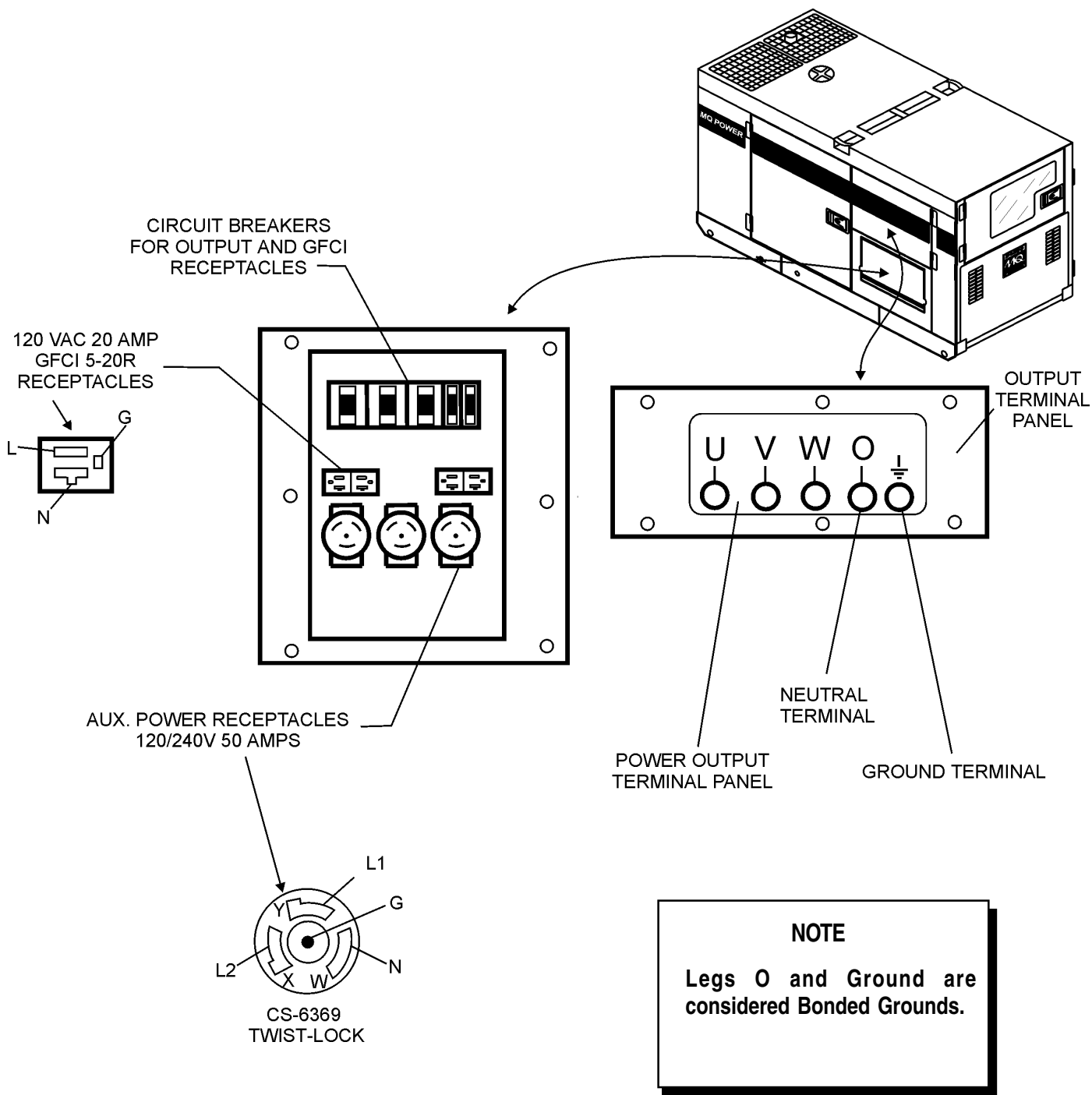

Figure 12. Output Panel Location

DCA-40SSAI — OUTPUT AMPERAGE SETUP

Output Terminal Panel Available Voltages

A wide range of voltages are available to supply load to many different applications. Voltages may be selected by using the voltage selector switch and depending how you hookup your hard wire connection to the generator. To obtain some of the voltages listed, fine adjustment with the voltage regulator on the control panel is necessary. See Table 8 for available voltages the generator will supply.

Over Current Relay

An over current relay is connected to the circuit breaker. During an over current situation, both the circuit breaker and the over current relay will trip. If the circuit breaker can not be reset, the reset button on the over current relay must be pressed. The over current relay is located inside the control box.

Table 8. Voltages Available

Three Phase (Switchable)	208 VOLT	220 VOLT	240 VOLT	416 VOLT	440 VOLT	480 VOLT
Single Phase (Switchable)	120 VOLT	127 VOLT	139 VOLT	240 VOLT	254 VOLT	277 VOLT

CAUTION :



NEVER switch Voltage Selector Switch position while the engine is engaged.

Maximum Amps

Table 9 shows the maximum amps the generator will provide. Do not exceed the maximum amps listed.

Voltage Selector Switch Locking Button

The voltage selector switch has a locking button to protect the generator and generator load from being switched while the engine is running. To lock the voltage selector switch, press in the red button located on the voltage selector switch, and use a pad lock to hold it into this position.

Table 9. Maximum Amps

Rated Voltage	Maximum Amps
Single Phase 120 Volt	100 amps (4 wire)
Single Phase 240 Volt	50 amps (4 wire)
Three Phase 240 Volt	108 amps
Three Phase 480 Volt	54 amps

DCA-40SSAI — OUTPUT AMPERAGE SETUP

Receptacle Use

When the UVWO terminals are providing power, the receptacle power availability will decrease. Do not exceed receptacle power as listed on Table 10.

Table 10. Receptacle Use		
Power in Use		Receptacle Power Available
240/480V 3-Phase	240/120V Single Phase or Twist Lock CS6369	Duplex NEMA 5-20R 120V
KVA	KW	KW
45	26	0
40.9	24.8	1.2
36.7	23.6	2.4
32.6	22.4	3.6
28.4	21.2	4.8

How To Read The Output Terminal Gauges.

The gauges (Figure 15 and 17) and change-over switches on the control panel DO NOT effect the generator output. They are to help observe how much power is being supplied at the UVWO legs.

When the voltage selector switch is in the 240/120V position (Figure 13), place the AC voltmeter change-over switch to the W-U position (Figure 14) and the AC ammeter change-over switch to the U or W position (Figure 16) to read the output on the selected leg.

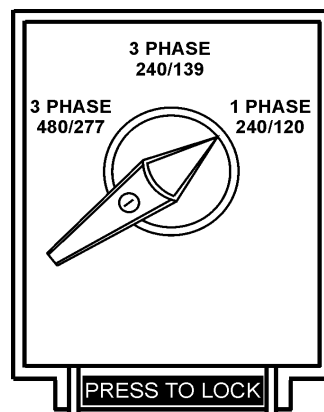

Figure 13. Voltage Selector Switch 240/120V Single Phase Position

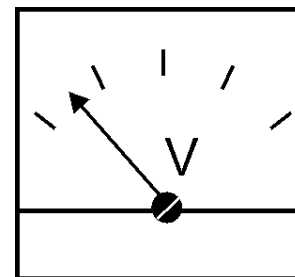
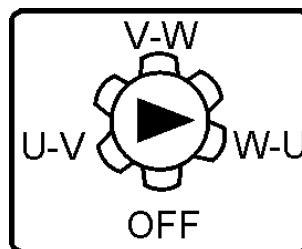

Figure 14 and 15. AC Voltmeter Change-over switch and Voltmeter Gauge

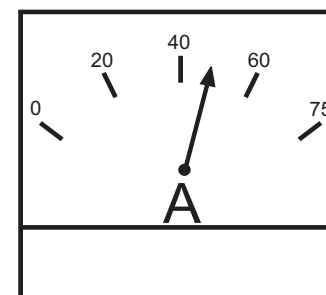
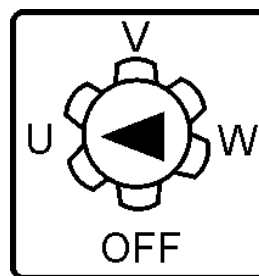

Figure 16 and 17. AC Ammeter Change-over Switch and Ammeter Gauge

NOTE

When using plural single phase voltages, make sure to balance the load on each of the single phase legs.

DCA-40SSAI — OUTPUT VOLTAGE SETUP

240/120V Hard Wire Hookup

With the voltage selector set and locked at 'single phase 240/120' and using single phase 120 volts, the generator will provide three legs available with 100 amps each on three different circuits (Figure 18).

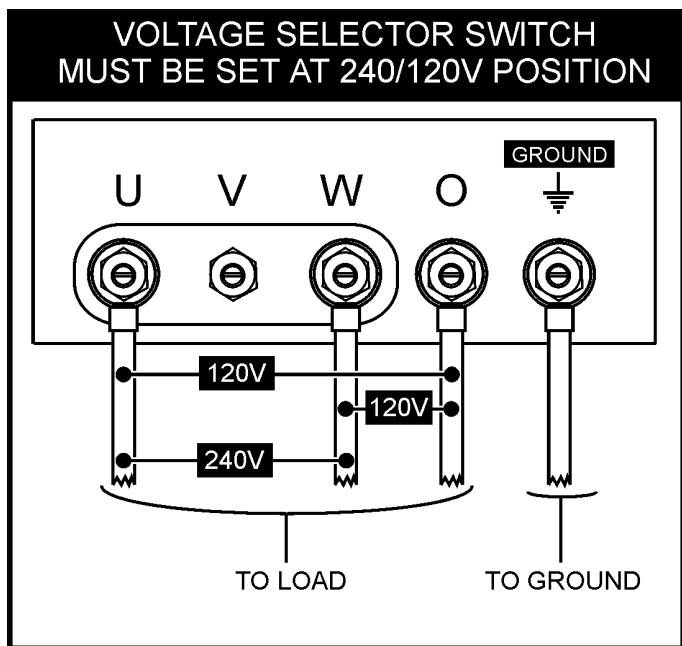

Figure 18. Hard Wire Hookup at 240/120V Position

480/240V Hard Wire Hookup

With the voltage selector set and locked at '3 phase 480/277' (Figure 19) and using the 3-phase 240 hookup, it will provide one circuit available at 108 amps with any two wires plus the ground (Figure 20).

When using the 3-phase 480 volts hookup, it will provide one circuit available at 50 amps with all three wires plus ground.

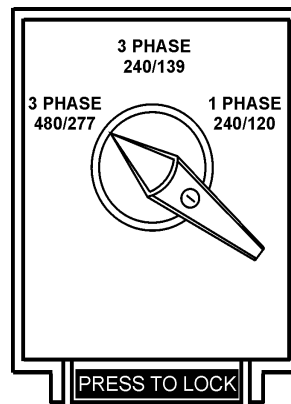

Figure 19. Voltage Selector Switch 480/277V Three Phase Position

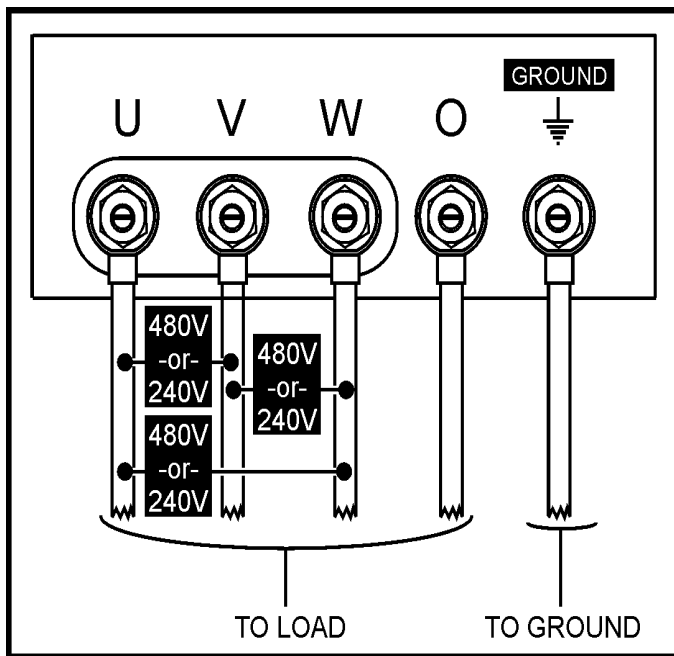

Figure 20. Hard Wire Hookup at 480/240V Position

Voltage Selector Switch- 3 Phase 480/277V Position

The following are additional voltages available when the voltage selector switch is in the '3 phase 480/277V' position.

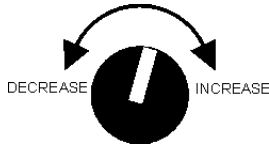

Figure 21. Voltage Regulator Knob

3 Phase, 480V, 440V, or 416 Volt

This setting can provide 3-phase power at 480, 440, or 416 volts. After hooking up the hard wires to the lugs as shown in Figure 22, 480 volts can be obtained with the voltage regulator knob turned toward maximum; 440 volts can be obtained with the voltage regulator knob is turned down; and 416 volts can be obtained with the voltage regulator knob is at the lowest setting.

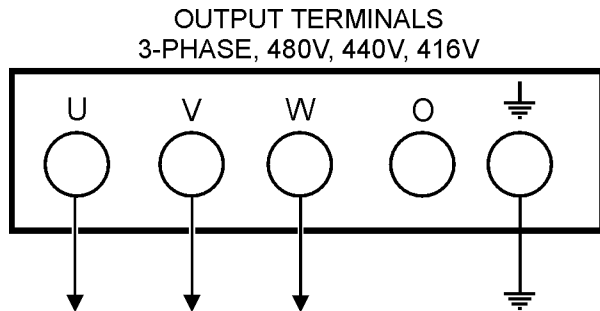

Figure 22. Hard Wire Hookup for Three Phase 480V, 440V, or 416V

Single Phase: 480V, 440V, or 416 Volt

This setting can provide single phase power at 480, 440, or 416 volts. After hooking up the hard wires to the lugs as shown in Figure 23, 480 volts can be obtained with the voltage regulator knob turned toward maximum; 440 volts can be obtained with the voltage regulator knob is turned down; and 416 volts can be obtained with the voltage regulator knob is at the lowest setting.

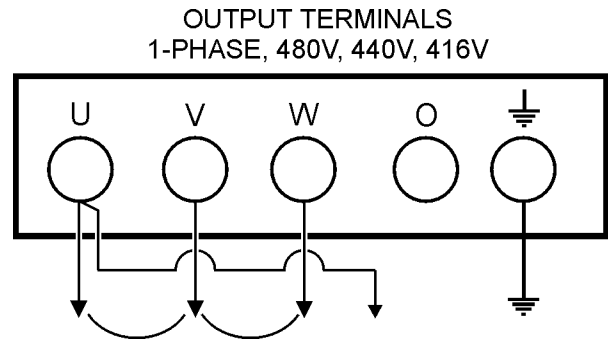

Figure 23. Hard Wire Hookup for Single Phase 480V, 440V, or 416V

Single Phase: 277V, 254V, or 240V

This setting can provide single phase power at 277, 254, or 240 volts. After hooking up the hard wires to the lugs as shown in Figure 24, 277 volts can be obtained with the voltage regulator knob turned toward maximum; 254 volts can be obtained with the voltage regulator knob is turned down; and 240 volts can be obtained with the voltage regulator knob is at the lowest setting.

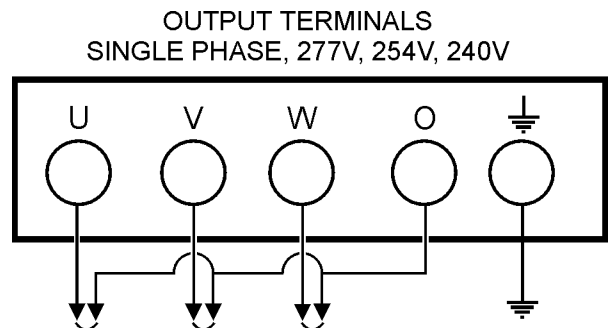

Figure 24. Hard Wire Hookup for Single Phase 277V, 254V, or 240V

Voltage Selector Switch- 3 Phase 240/139V Position

The following are additional voltages available when the voltage selector switch is in the '3 phase 240/139V' position.

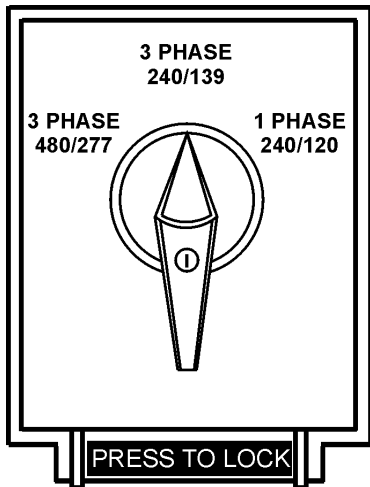

Figure 25. Voltage Selector Switch 240/139V Three Phase Position

3 Phase, 240V, 220V, or 208 Volt

This setting can provide 3-phase power at 240, 220, or 208 volts. After hooking up the hard wires to the lugs as shown in Figure 26, 240 volts can be obtained with the voltage regulator knob turned toward maximum; 220 volts can be obtained with the voltage regulator knob is turned down; and 208 volts can be obtained with the voltage regulator knob is at the lowest setting.

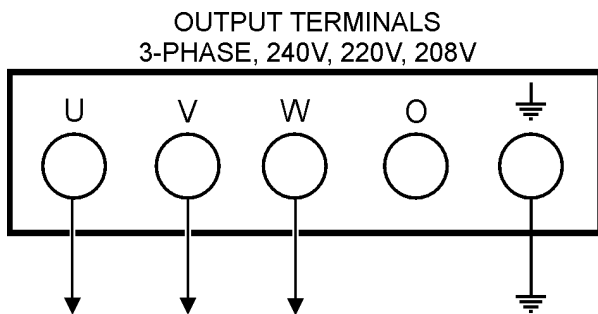

Figure 26. Hard Wire Hookup for Three Phase 240V, 220V, or 208V

Single Phase: 240V, 220V, or 208 Volt

This setting can provide single phase power at 240, 220, or 208 volts. After hooking up the hard wires to the lugs as shown in Figure 27, 240 volts can be obtained with the voltage regulator knob turned toward maximum; 220 volts can be obtained with the voltage regulator knob is turned down; and 208 volts can be obtained with the voltage regulator knob is at the lowest setting.

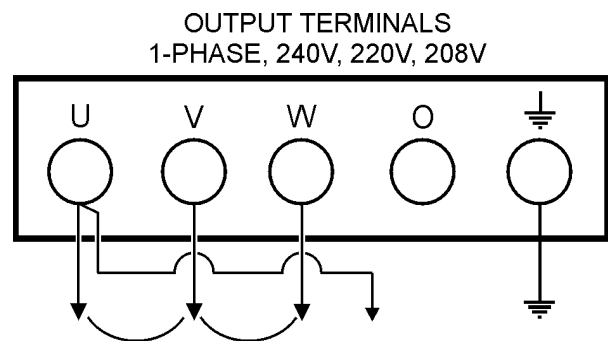

Figure 27. Hard Wire Hookup for Single Phase 240V, 220V, or 208V

Single Phase: 139V, 127V, or 120V

This setting can provide single phase power at 139, 127, or 120 volts. After hooking up the hard wires to the lugs as shown in Figure 28, 139 volts can be obtained with the voltage regulator knob turned toward maximum; 127 volts can be obtained with the voltage regulator knob is turned down; and 120 volts can be obtained with the voltage regulator knob is at the lowest setting.

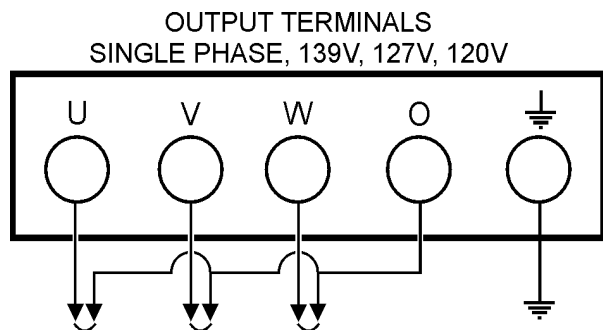

Figure 28. Hard Wire Hookup for Single Phase 139V, 127V, or 120V

Voltage Selector Switch- Single Phase 240/120V

Position

The following are additional voltages available when the voltage selector switch is in the 'single phase 240/120V' position.

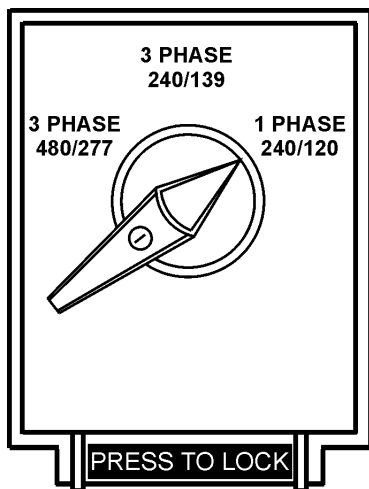

Figure 29. Voltage Selector Switch 240/120V Single Phase Position

Single Phase: 120 Volt

This setting can provide single phase power at 120 volts. After hooking up the hard wires to the lugs as shown in Figure 31, 120 volts can be obtained with the voltage regulator knob turned to fine tune.

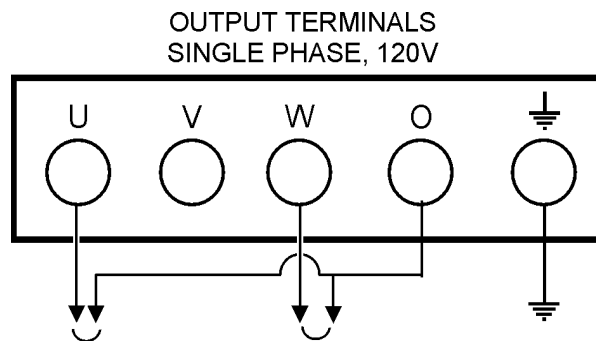

Figure 31. Hard Wire Hookup for Single Phase, 120 volt

Single Phase, 240 Volt

This setting can provide single phase power at 240 volts. After hooking up the hard wires to the lugs as shown in Figure 30, 240 volts can be obtained with the voltage regulator knob turned to fine tune.

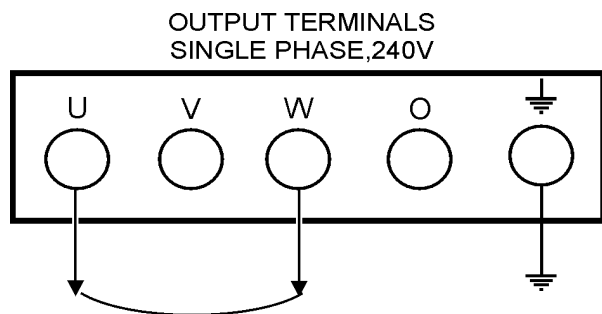

Figure 30. Hard Wire Hookup for Single Phase 240 volt

Outdoor Installation

Install the generator in a location where it will not be exposed to rain or sunshine. Make sure the generator is on secure level ground so that it cannot slide or shift around. Also install the generator in a manner so that the exhaust will not be discharged in the direction of nearby homes.

The installation site must be relatively free from moisture and dust. All electrical equipment should be protected from excessive moisture. Failure to do will result in deterioration of the insulation and will result in short circuits and grounding.

Foreign materials such as dust, sand, lint and abrasive materials have a tendency to cause excessive wear to engine and alternator parts.

CAUTION :



Pay close attention to ventilation when operating the generator inside tunnels and caves. The engine exhaust contains noxious elements. Engine exhaust must be routed to a ventilated area.

Indoor Installation

Exhaust gases from diesel engines are extremely poisonous. Whenever an engine is installed indoors the exhaust fumes must be vented to the outside. The engine should be installed at least two feet from any outside wall. Using an exhaust pipe which is too long or too small can cause excessive back pressure which will cause the engine to heat excessively and possibly burn the valves.

Mounting

The generator must be mounted on a solid foundation (such as concrete) and set firmly on the foundation to isolate vibration of the generator when it is running. The generator must set at least 6 inches above the floor or grade level (in accordance to NFPA 110, Chapter 5-4.1). DO NOT remove the metal skids on the bottom of the generator. They are to resist damage to the bottom of the generator and to maintain alignment.

CAUTION :

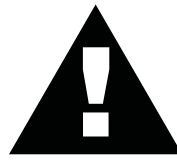

An electric shock may happen when vibrators are used. Pay close attention to handling when operating vibrators and always use rubber boots and gloves to insulate the body from electrical shock.

Generator Grounding

To guard against electrical shock and possible damage to the equipment, it is important to provide a good **EARTH** ground.

Article 250 (Grounding) of the National Electrical Code (NEC) provides guide lines for proper grounding and specifies that the cable ground shall be connected to the grounding system of the building as close to the point of cable entry as practical.

NEC articles 250-64(b) and 250-66 set the following grounding requirements:

1. Use one of the following wire types to connect the generator to earth ground.
 - a. Copper - 10 AWG (5.3 mm²) or larger.
 - b. Aluminum - 8 AWG (8.4 mm²) or larger.
2. When grounding the generator (Figure 31) connect the ground cable between the lock washer and the nut on the generator and tighten the nut fully. Connect the other end of the ground cable to earth ground.
3. NEC article 250-52(c) specifies that the earth ground rod should be buried a minimum of 8 ft. into the ground.

NOTE

When connecting the generator to any buildings electrical system **ALWAYS** consult with a licensed electrician.

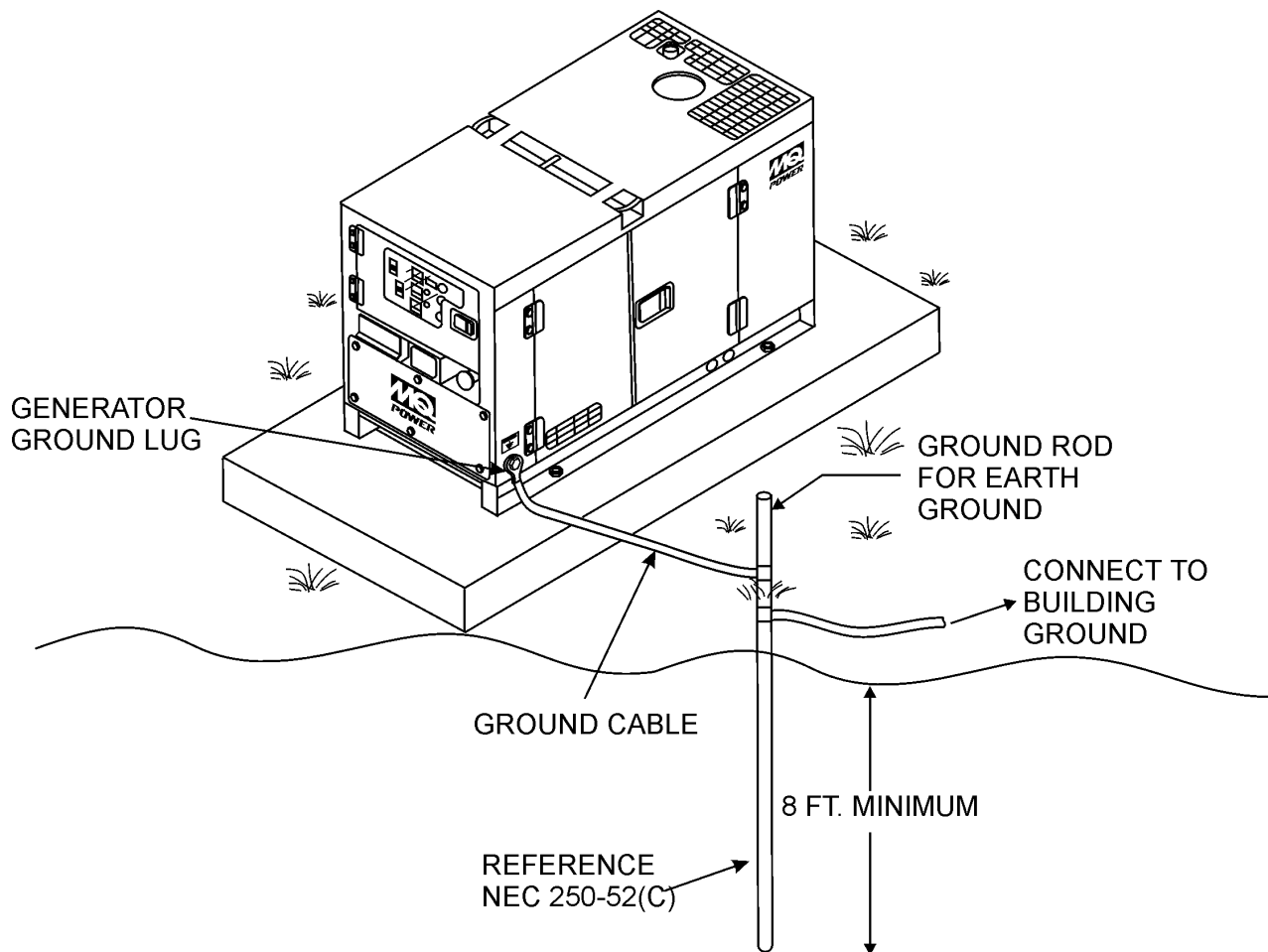

Figure 31. Typical Generator Grounding Application

General Inspection Prior to Operation

The DCA-40SSAI generator has been thoroughly inspected and accepted prior to shipment from the factory. However, be sure to check for damaged parts or components, or loose nuts and bolts, which could have occurred in transit.

Extension Cable

When electric power is to be provided to various tools or loads at some distance from the generator, extension cords are normally used. Cables should be sized to allow for distance in length and amperage so that the voltage drop between the generator and point of use (load) is held to a minimum. Use the Cable Selection Guide (Table 11) as a guide for selecting proper cable size.

Circuit Breakers

To protect the generator from an overload, a 3-pole, 100 amp, **main** circuit breaker is provided to protect the UNV output terminals from overload. In addition two single-pole, 20 amp **GFCI** circuit breakers are provided to protect the GFCI receptacles from overload. Three 50 amp **load** circuit breakers have also been provided to protect the load side of the generator from overload. Make sure to switch **ALL** circuit breakers to the "OFF" position prior to starting the engine.

NOTE

ALWAYS consult with a licensed electrician for correct extension cord wire size.

Table 11. Cable Selection (60 Hz, Single Phase Operation)

Current in Amperes	Load In Watts		Maximum Allowable Cable Length			
	At 120 Volts	At 240 Volts	#10 Wire	#12 Wire	#14 Wire	#16 Wire
2.5	300	600	1000 ft.	600 ft.	375 ft.	250 ft.
5	600	1200	500 ft.	300 ft.	200 ft.	125 ft.
7.5	900	1800	350 ft.	200 ft.	125 ft.	100 ft.
10	1200	2400	250 ft.	150 ft.	100 ft.	
15	1800	3600	150 ft.	100 ft.	65 ft.	
20	2400	4800	125 ft.	75 ft.	50 ft.	

CAUTION: Equipment damage can result from low voltage.

Lubrication Oil

Fill the engine crankcase with lubricating oil through the filler hole, but do not overfill. Make sure the generator is level. With the dipstick inserted all the way, but without being screw into the filler hole, verify that the oil level is maintained between the two notches (Figure 32) on the dipstick. See Table 12 for proper selection of engine oil.

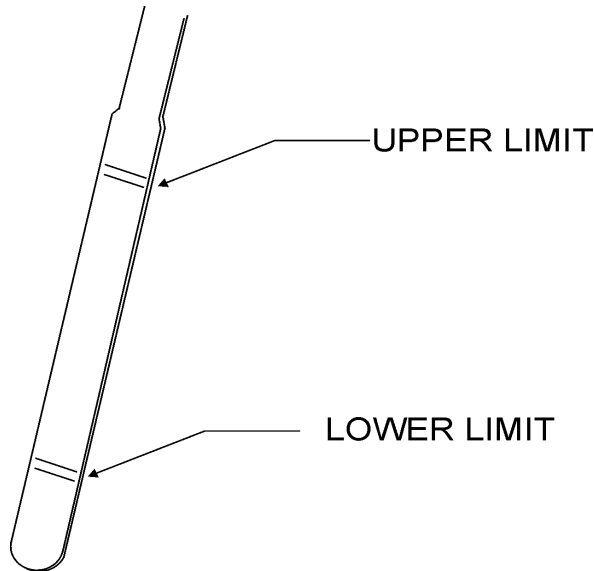

Figure 32. Engine Oil Dipstick

When checking the engine oil, be sure to check if the oil is clean and viscous. If the oil is not clean, drain the oil by removing the oil drain plug, and refill with the specified amount of oil as outlined in the **Isuzu Engine Owner's Manual**.

Fuel

Fill the fuel tank with clean and fresh **diesel fuel**. **DO NOT** fill the tank beyond capacity.

Pay attention to the fuel tank capacity when replenishing fuel. Refer to the fuel tank capacity listed on page 23 Specification Table 7.

The fuel tank cap must be closed tightly after filling. Handle fuel in a safety container. If the container does not have a spout, use a funnel. Wipe up any spilled fuel immediately.

CAUTION :



Never fill the fuel tank while the engine is running or in the dark. Gasoline spillage on a hot engine can cause a fire or explosion. If gasoline spillage occurs, wipe up the spilled gasoline completely

to prevent fire hazards.

Coolant

Use only drinkable tap water. If hard water or water with many impurities is used, the inside of the engine and radiator may become coated with deposits and cooling efficiency will be reduced. See maintenance section on page 52 and 53 on instructions to flush out radiator.

An anticorrosion additive added to the water will help prevent deposits and corrosion in the cooling system.

Table 12. Recommended Motor Oil	
Temperature Range	Type Oil
104° F ~ 23° F (40° C ~ -5°C)	SAE 30
23° F ~ 5° F (-5° C ~ -15°C)	SAE 20 or SAE 10W-30
Below 5° C (-15°)	SAE 10W or SAE 10W-30

CAUTION :



When adding coolant or antifreeze to the radiator, do not remove the radiator cap until the unit has completely cooled.

Day-to-day addition of coolant is done from the reserve tank. When adding coolant to the radiator, **DO NOT** remove the radiator cap until the unit has completely cooled. See Table 13. for engine, radiator, and reserve tank coolant capacities. Make sure the coolant level in the reserve tank is always between the "H" and the "L" markings.

Table 13. Coolant Capacity

Engine and Radiator	4 Gal. (15 L)
Reserve Tank	0.26 Gal. (1L)

Operation in Freezing Weather

When operating in freezing weather, be certain the proper amount of antifreeze (Table 14) has been added.

Table 14. Anti-Freeze Operating Temperatures

Vol % Anti-Freeze	Freezing Point		Boiling Point	
	°C	°F	°C	°F
40	-24	-12	106	222
50	-37	-34	108	226

NOTE

When the antifreeze is mixed with water, the antifreeze mixing ratio must be less than 50%.

Cleaning the Outer Radiator

The engine may overheat if the radiator fins become overloaded with dust or debris. Periodically clean the radiator fins with compressed air. Cleaning inside the radiator is dangerous, so clean only with the engine turned off and the battery disconnected.

Air Cleaner

Periodic cleaning/replacement is necessary. Inspect it in accordance with the **Isuzu Engine Owner's Manual**.

Fan Belt Tension

A slack fan belt may contribute to overheating, or to insufficient charging of the battery. Inspect the fan belt for damage and wear and adjust it in accordance with the **Isuzu Engine Owner's Manual**.

The fan belt tension is proper if the fan belt bends 10 to 15 mm (Figure 33) when depressed with the thumb as shown below. Never place hands near the belts or fan while the generator is running.

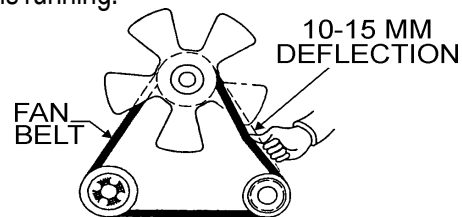

Figure 33. Fan Belt Tension

CAUTION :



Never place hands near the belts or fan while the generator set is running.

Adjusting Fan Belt

If the fan belt does not have the 10 to 15 mm deflection follow the procedure below to adjust:

Loosen the alternator adjusting plate and alternator mounting bolt.

Pivot the alternator at the mounting bolt toward the engine left or right until the belt reflects the proper tension.

Tighten the mounting bolt and the adjusting bolt.

Battery

This unit is of negative ground. **DO NOT** connect in reverse. Always maintain battery fluid level between the specified marks. Battery life will be shortened, if the fluid level is not properly maintained. Add only distilled water when replenishment is necessary. **DO NOT** over fill.

The battery is sufficiently charged if the specific gravity of the battery fluid is 1.28 (at 68° F). If the specific gravity should fall to 1.245 or lower, it indicates that the battery is dead and needs to be recharged or replaced.

Check to see whether the battery cables are loose. Poor contact may result in poor starting or malfunctions. Always keep the terminals firmly tightened. Coating the terminals with a thin film of grease will help to inhibit corrosion.

Battery Cable Installation

ALWAYS be sure the battery cables (Figure 34) are properly connected to the battery terminals as shown below. The **RED** cable is connected to the positive terminal of the battery, and the **BLACK** cable is connected to the negative terminal of the battery.

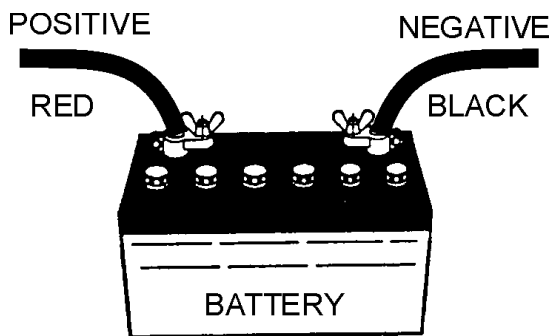

Figure 34. Battery Connections

Alternator

The polarity of the alternator is negative grounding type. When an inverted circuit connection takes place, the circuit will be in short circuit instantaneously resulting the alternator failure.

Do not put water directly on the alternator. Entry of water into the alternator leads an electrolyte corrosion causing an alternator failure.

Before charging the battery with an external electric source, be sure to disconnect the battery cables.

CAUTION :



If the battery cable is connected incorrectly, damage to the generator will occur. Pay close attention to the polarity of the battery when connecting the battery.

When connecting battery do the following:

1. **DO NOT** connect the battery cables to the battery terminals when the key is in the ignition and is set in 'START' mode. **ALWAYS** remove the key from the ignition and the ignition switch is in the OFF position when connecting the battery.
2. Place a small amount of grease around both battery terminals. This will ensure a good connection and will help prevent corrosion around the battery terminals.

CAUTION :



Inadequate battery connections may cause poor starting of the generator, and create other malfunctions.

Wiring

Inspect the entire generator for bad or worn electrical wiring or connections. If any wiring or connections are exposed (insulation missing) replace wiring immediately.

Piping and Hose Connection

Inspect all piping, oil hose, and fuel hose connections for wear and tightness. Tighten all hose clamps and check hoses for leaks.

If any hose (fuel or oil) lines are defective replace them immediately.

Single Phase Load

Always be sure to check the nameplate on the generator and equipment to insure the wattage, amperage and frequency requirements are satisfactorily supplied by the generator for operating the equipment.

Generally, the wattage listed on the nameplate of the equipment is its rated output. Equipment may require 130—150% more wattage than the rating on the nameplate, as the wattage is influenced by the efficiency, power factor and starting system of the equipment.

NOTE

If wattage is not given on the equipment's name plate, approximate wattage may be determined by multiplying nameplate voltage by the nameplate amperage.

$$\text{WATTS} = \text{VOLTAGE} \times \text{AMPERAGE}$$

The power factor of this generator is 1.0. See Table 15. below when connecting loads.

Table 15. Power Factor By Load

Type Of Load	Power Factor
Single-phase induction motors	0.4 - 0.75
Electric heaters, incandescent lamps	1.0
Fluorescent lamps, mercury lamps	0.4 - 0.9
Electronic devices, communication equipment	1.0
Common power tools	0.8

Three Phase Load

When calculating the power requirements for 3-phase power use the following equation:

$$\text{KVA} = \frac{\text{VOLTAGE} \times \text{AMPERAGE} \times 1.732}{1000}$$

CAUTION:

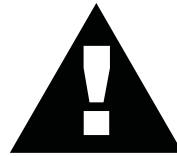

Motors and motor-driven equipment draw much greater current for starting than during operation.

An inadequate size connecting cable which cannot carry the required load can cause a voltage drop which can burn out the appliance or tool and overheat the cable.

- When connecting a resistance load such as an incandescent lamp or electric heater, a capacity of up to the generating set's rated output (kW) can be used.
- When connecting a fluorescent or mercury lamp, a capacity of up to the generating set's rated output (kW) multiplied by 0.6 can be used.
- When connecting an electric drill or other power tools, pay close attention to the required starting current capacity.

If wattage is not available on the equipment, approximate wattage may be determined by multiplying the nameplate voltage by the nameplate amperage for three-phase:
 $\text{WATTS} = 1.732 \times \text{VOLTAGE} \times \text{AMPERAGE}$

CAUTION:



Before connecting this generator to any building's electrical system, a licensed electrician must install an isolation (transfer) switch. Serious injury or death may result without this transfer switch.

NOTE

If output (kVA) is not given on the equipment nameplate, approximate output may be determined by multiplying voltage by amperage by $\sqrt{3}$

WARNING:



The engine's exhaust contains harmful emissions. **ALWAYS** ventilate the exhaust when operating inside tunnels, excavations or buildings. Direct exhaust away from nearby personnel.

Before Starting Engine

1. Check the lubricating oil level prior to starting the engine. Make sure the generator is level. The oil level must be maintained between two notches on the dipstick.
2. When there is not enough lubricating oil, fill the crankcase with high grade motor oil. Use a high quality detergent oil classified CC or higher (See Table 12 on page 43).
3. Check the coolant level in the radiator and subtank. Replenish with antifreeze as necessary. Always maintain the coolant level between the **FULL** and **LOW** markings on the coolant container. Be sure that the radiator cap is fastened securely.
4. Check the fuel level on the fuel gauge. If fuel is low, fill the fuel tank with clean fresh unleaded automotive diesel. If diesel spillage occurs, completely wipe up the spilled fuel immediately.

Before Starting Generator and Control Panel

CAUTION:



NEVER start the engine with the **main, GFCI** or **load** circuit breakers in the **ON** position.

1. Be sure to disconnect the electrical load and switch the **main, load** and **G.F.C.I.** circuit breakers (Figure 35) to the "OFF" position prior to starting the engine.

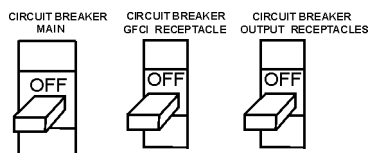

Figure 35. Main, GFCI and Load Circuit Breakers

2. Connect the load to the UNV terminals as shown in Figure 36. These terminals can be found on the output terminal panel, (see page 33 Figure 12). To gain access to the output terminals lift the UNV cover. Tighten terminal nuts securely to prevent load wires from slipping out.

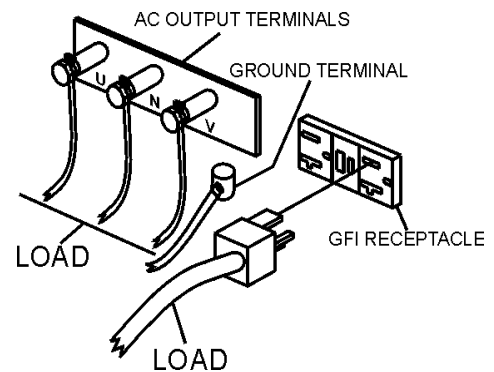

Figure 36. UNV Terminal Lugs (Load)

3. Connect the negative battery cable (BLACK) to the negative post on the battery (Figure 37).

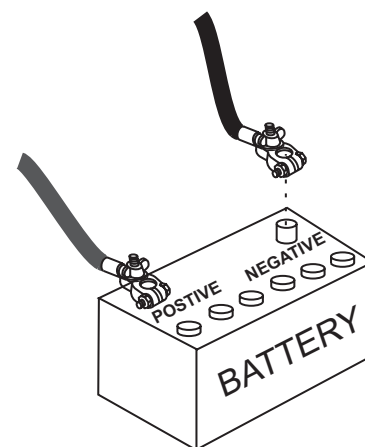
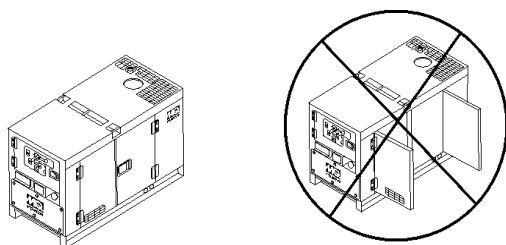

Figure 37. Battery Connections

DCA-40SSAI — GENERATOR START-UP PROCEDURE

4. Close all engine enclosure doors (Figure 38).



CORRECT

INCORRECT

Figure 38. Engine Enclosure Doors

5. Check the voltage selection switch (Figure 39) is at the desired voltage.

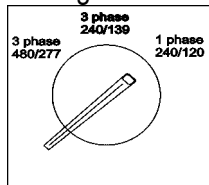

Figure 39. Voltage Selection Switch

6. Turn and push the engine throttle control lever (Figure 40) to 'Low'.

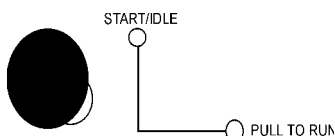

Figure 40. Engine Throttle Control Lever (low)

7. Preheat the engine by turning the ignition key to the left. Once the preheat lamp luminates, turn the key to the farthest right to start the engine. Once the engine start to crank, release the key to 'operation' (Figure 41).

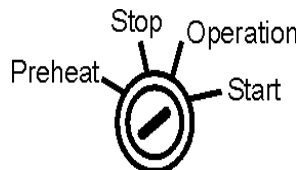

Figure 41. Starter Switch

8. Once the engine is warm and the engine is running properly, pull and turn the engine throttle control lever to 'High' (Figure 42).

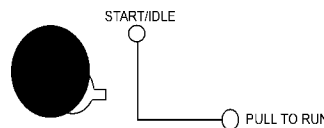

Figure 42. Engine Speed Switch (high)

9. The generator's frequency meter (Figure 43) displays the 60 cycle output frequency in HERTZ.

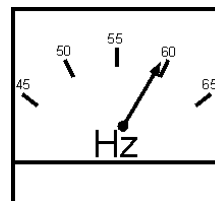

Figure 43. Frequency Meter (Hz)

10. The generator's voltage meter (Figure 44) displays the 120 VAC in VOLTS. If the voltage is not within the specified frequency tolerance, use the voltage adjustment control knob (Figure 45) to increase or decrease the desired voltage.

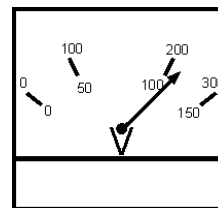

Figure 44. Voltage Meter (Volts)

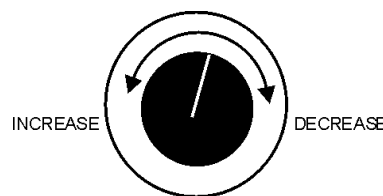

Figure 45. Voltage Adjust Control Knob

DCA-40SSAI — GENERATOR START-UP PROCEDURE

11. The ammeter (Figure 46) will indicate zero amps with no load applied. When a load is applied, this meter will indicate the amount of current that the load is drawing from the generator's alternator.

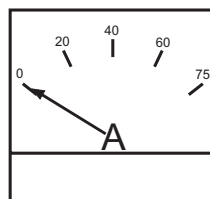

Figure 46. Ammeter (No Load)

12. The engine oil pressure gauge (Figure 47) will indicate the oil pressure (kg/cm²) of the engine. Under normal operating conditions the oil pressure is approximately 25 psi.

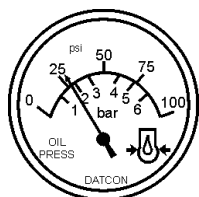

Figure 47. Oil Pressure Gauge

13. The coolant temperature gauge (Figure 48) will indicate the coolant temperature. Under normal operating conditions the coolant temperature is between 165 and 215 degrees Fahrenheit.

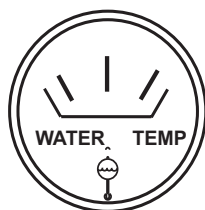

Figure 48. Coolant Temperature Gauge

14. The tachometer (Figure 49) will indicate the speed of the engine when the generator is operating. Under normal operating conditions this speed is approximately 1800 RPM's.

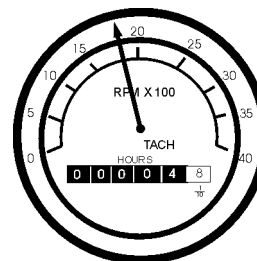

Figure 49. Engine Tachometer

15. Turn the MAIN, GFCI and LOAD circuit breakers to their ON position (Figure 50).

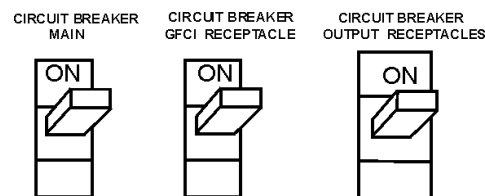

Figure 50. Main and GFCI Circuit Breakers

16. Observe the generator's ammeter (Figure 51) and verify it reads the anticipated amount of current with respect to the load. The ammeter will only display a current reading if the load is in use.

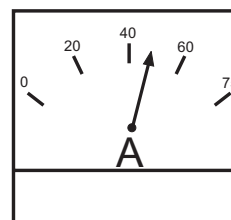

Figure 51. Ammeter (Load)

17. The generator will run until manually stopped or an abnormal condition occurs.

DCA-40SSAI — GENERATOR SHUTDOWN PROCEDURE

ENGINE SHUTDOWN

To shutdown the generator, use the following procedure:

1. Switch both the MAIN, GFCI and LOAD circuit breakers (Figure 52) to the “OFF” position.

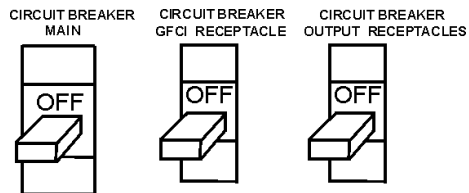

Figure 52. Main, GFCI and Load circuit breakers

2. Turn and push the engine throttle control lever (Figure 53) to the idle (low) position.

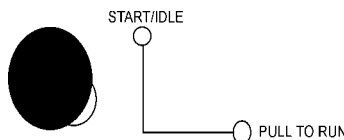

Figure 53. Engine Throttle Control Lever

3. Let the engine cool by running it for 3-5 minutes with no load applied.
4. Turn the starter switch key to ‘Stop’ position (Figure 54).

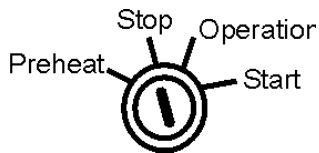

Figure 54. Off/Manual Auto Switch

5. Remove the load from the UNV terminal strip.

EMERGENCY STOP

1. To stop the engine in the event of an emergency, switch the MAIN, GFCI and LOAD circuit breakers to ‘OFF’ position.
2. Turn the starter switch key to ‘Stop’ position.

General Inspection

Prior to each use, the generator should be cleaned and inspected for deficiencies. Check for loose, missing or damaged nuts, bolts or other fasteners. Also check for fuel, oil, and coolant leaks.

Engine Side (Refer to the Engine Instruction Manual)

Air Cleaner

Every 50 hours: Remove air cleaner element and clean heavy duty paper element with kerosene, or foam element with liquid detergent and hot water. Wrap foam element in a cloth and squeeze dry. For heavy duty paper element, wipe excess kerosene with towel.

The air cleaner is equipped with an indicator. After the dirty air cleaner has been replaced, press the dust indicator button to reset the indicator.

Fuel Addition

Add diesel fuel (the grade may vary according to season and locations). Always pour through the mesh filter.

Removing Water from the Fuel Tank

After prolonged use, water and other impurities accumulate in the bottom of the tank. Occasionally remove the drain cock and drain the contents. During cold weather, the more empty volume inside the tank, the easier it is for water to condense. This can be reduced by keeping the tank full as much as possible.

Air Removal

If air enters the fuel injection system of a diesel engine, starting becomes impossible. After running out of fuel, or after disassembling the fuel system, bleed the system according to the following procedure.

To restart after running out of fuel, turn the switch to the "ON" position for 15-30 seconds. Try again, if needed. This unit is equipped with an automatic air bleeding system.

Service Daily

If the engine is operating in very dusty or dry grass conditions, a clogged air cleaner will result. This can lead to a loss of power, excessive carbon buildup in the combustion chamber in high fuel consumption.

Cleaning the Fuel Strainer

Clean the fuel strainer if it contains dust or water. Remove dust or water in the strainer cap and wash it in gasoline. Securely fasten the fuel strainer cap so that fuel will not leak. Check the fuel strainer every 200 hours of operation or once a month.

Check Oil Level

Check the crankcase oil level prior to each use, or when the fuel tank is filled. Insufficient oil may cause severe damage to the engine. Make sure the generator is level. The oil level must be between the two notches on the dipstick as shown in Figure 32, page 43.

Replacing Oil Filter

- Detach the oil filter cartridge with a filter wrench.
- Apply a film of oil to the gasket for the cartridge.
- Screw in the cartridge by hand. When the gasket is in contact with the seal surface, tighten the cartridge one or two more times by hand.
- After the oil cartridge has been replaced, the engine oil will drop slightly. Run the engine for a while and check for leaks before adding more oil if needed. Clean excessive oil from engine.

Replacing Fuel Filter

- Replace the fuel filter cartridge with new one every 400 hours or so.
- Apply fuel oil thinly over the gasket and hand-tighten the cartridge into position.
- Vent any air.

Fuel Injection Nozzle

- Use an injection nozzle tester to check the static injection starting pressure and the fuel spray conditions.
- Abnormal fuel consumption will lead to a lowered output and blackish exhaust smoke. The required injection starting pressure should be 14.7MPa (150kg/cm², 2130psi).

Feed Pump Strainer Cleaning

The strainer is incorporated in the feed pump inlet side joint bolt. Clean the strainer with compressed air and rinse it in the fuel oil.

Flushing Out Radiator and Replacing Coolant

- Open both cocks located at the crankcase side and at the lower part of the radiator and drain coolant. Open the radiator cap while draining. Remove the overflow tank and drain.
- Check hoses for softening and kinks. Check clamps for signs of leakage.
- Flush the radiator by running clean tap water through radiator until signs of rust and dirt are removed. **DO NOT** clean radiator core with any objects, such as a screwdriver.
- Tighten both cocks and replace the overflow tank.
- Replace with coolant (see page 44, Table 14 for mixture).
- Close radiator cap tightly.

CAUTION :



Allow engine to cool when flushing out radiator. Flushing the radiator while hot will damage radiator.

Valve Clearance Check

1. In order to bring No. 1 or No. 4 cylinder to top dead center in the compression stroke, align the notched line on the crank pulley with TDC mark on the timing gear case cover.
2. Do the adjustment on the circle marked valves in the below table where No. 1 cylinder is at the center in the compression stroke.
3. After adjustment started from either piston top center, turn the crankshaft 360° to align the notched line with the TDC mark to do the adjustment again on the remaining valve. See Table 16 and Figure 55 for valve arrangement.

Injection Timing Check and Adjustment

1. Bring No. cylinder to the top dead center on the compression stroke.
2. Turn the crankshaft pulley clockwise (viewed at engine front) and align the notched line on the crank pulley with the TDC mark on the timing gear case cover.

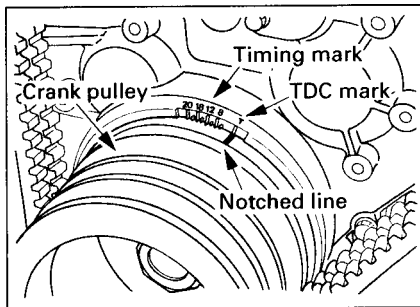

Figure 55. Valve Adjustment

NOTE:

Take necessary precautions to prevent dust and foreign particles in the pump interior when timing adjustments are made.

3. Remove the timing check hole cover at the front of injection pump to check the alignment between the pointer "a" on the injection pump gear lock plate and the projected area mark "b" on the timing gear case.
4. If "a" and "b" are in alignment, the timing is set correctly. If not, follow nos. 1-3 until the "a" and "b" are aligned.
5. Reversely turn the crankshaft pulley counterclockwise viewed at the engine front about 30° crank angle.
6. Remove No. 1 injection pipe from the engine.
7. Remove the injection pump No. 1 delivery valve holder, delivery valve and spring and reinstall the delivery valve holder on the original place.
8. Delivery valve holder tightening torque: 39~44Nm(29~33lbf.)
9. Slowly turn the crankshaft pulley clockwise and at the same time continue to feed the fuel with pumping the Feed pump. When the fuel stop to flow out from No. 1 delivery valve holder, stop pumping.
10. Observe and make sure which mark (injection starting angle line) on the timing gear case cover is aligning with the notched line on the crank pulley.
11. The timing line shows the injection starting crank angle of the engine.
12. The injection starting crank angle should be at the 14° timing mark.

**Table 16. Valve Adustment
(I=Inlet; E=Exhaust)**

Cylinder No.	1		2		3		4	
Valve Arrangement	I	E	I	E	I	E	I	E
When No. 1 is at top dead center in the compression stoke	X	X	X			X		
When No. 4 is at top dead center in the compression stroke				O	O		O	O

INSPECTION / MAINTENANCE		10 Hrs DAILY	250 Hrs	500 Hrs	1000 Hrs
ENGINE	Check Engine Fluid Levels	X			
	Check Air Cleaner	X			
	Check Battery Acid Level	X			
	Check Fan Belt Condition	X			
	Check for Leaks	X			
	Check for Loosening of Parts	X			
	Replace Engine Oil and Filter *1		X		
	Clean Air Filter		X		
	Drain Bottom of Fuel Tank		X		
	Clean Unit, Inside and Outside		X		
	Change Fuel Filter *2			X	
	Clean Radiator and Check Coolant Protection Level			X	
	Test Fuel Injection Nozzle			X	
	Replace Air Filter Element				X
	Check all Hoses and Clamps				X
	Check Valve Clearance				X
Check Injection Nozzle			X	X	
Clean Inside of Fuel Tank				X	
GENERATOR	Measure Insulation Resistance Over 3M ohms		X		

*1 Replace engine oil and filter at 100 hours, first time only.

*2 Replace fuel filter at 250 Hours, first time only.

Generator Storage

For storage of the generator for over 30 days, the following is required:

- Fill the fuel tank completely.
- Completely drain the oil from the crankcase and refill with fresh oil.
- Clean all external parts of the generator with a cloth.
- Cover the generating set and store in a clean, dry place.

DCA-40SSAI — ENGINE WIRING DIAGRAM

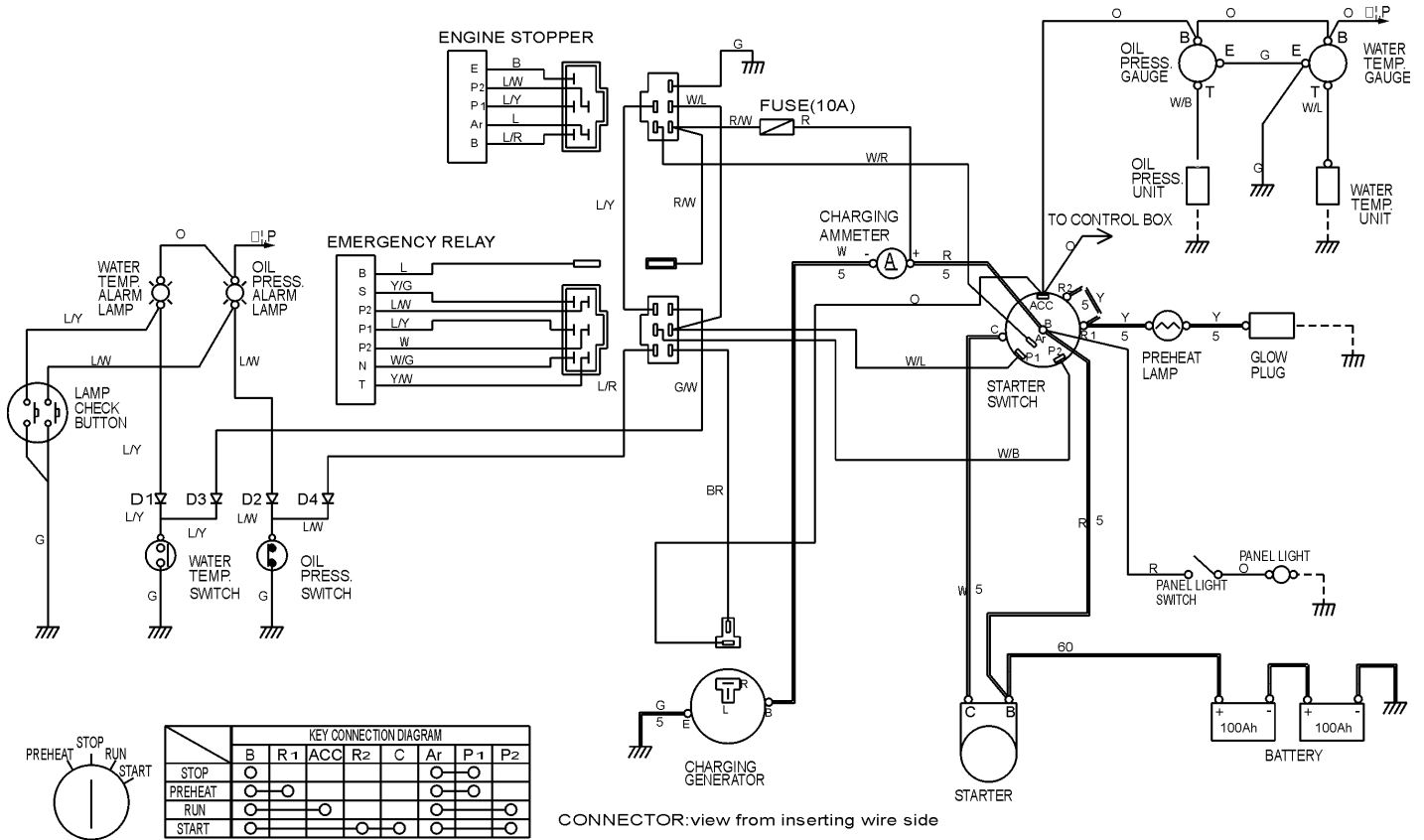

	KEY CONNECTION DIAGRAM							
	B	R 1	ACC	R2	C	Ar	P1	P2
STOP	○	○	○	○	○	○	○	○
PREHEAT	○	○	○	○	○	○	○	○
RUN	○	○	○	○	○	○	○	○
START	○	○	○	○	○	○	○	○

WIRE SIZE	COLOR CODE	
60: 60 mm ²	WIRE COLOR	WIRE COLOR
5: 5 mm ²	B BLACK	R RED
	L BLUE	W WHITE
	BR BROWN	Y YELLOW
	G GREEN	LB LIGHT BLUE
	GR GRAY	LG LIGHT GREEN
	V VIOLET	O ORANGE
	P PINK	

DCA-40SSAI — GENERATOR WIRING DIAGRAM

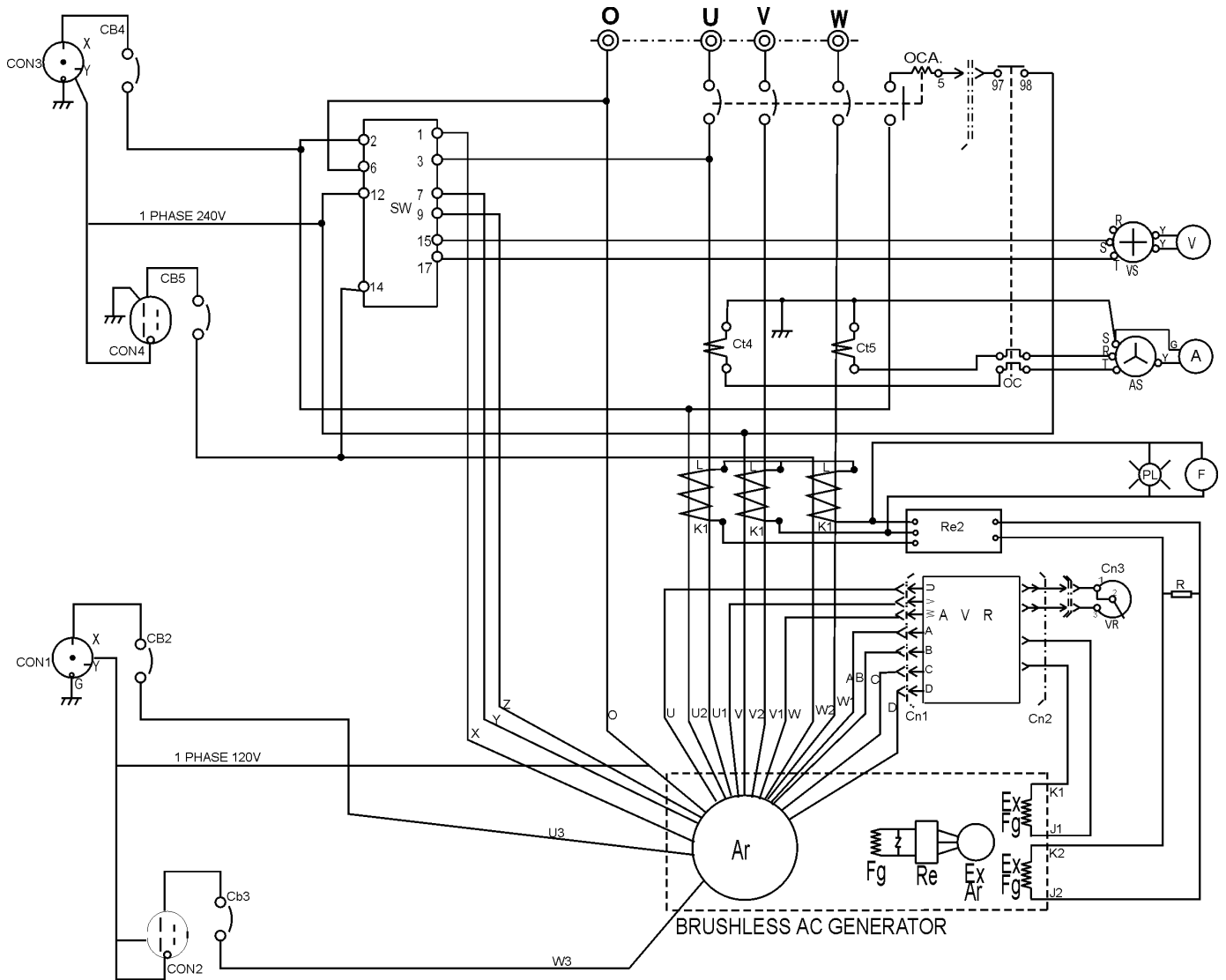

DCA-40SSAI — TROUBLESHOOTING (ENGINE)

Practically all breakdowns can be prevented by proper handling and maintenance inspections, but in the event of a breakdown, use the tables shown for

diagnosis based on the Engine Troubleshooting (Table 1 7). If the problem cannot be remedied, consult our company's business office or service plant.

TABLE 17. ENGINE TROUBLESHOOTING (PART 1)

SYMPTOM	POSSIBLE PROBLEM	SOLUTION
Engine does not start.	No fuel?	Replenish fuel.
	Air in the fuel system?	Bleed system.
	Water in the fuel system?	Remove water from fuel tank.
	Fuel pipe clogged?	Clean fuel pipe.
	Fuel filter clogged?	Clean or change fuel filter.
	Excessively high viscosity of fuel or engine oil at low temperature?	Use the specified fuel or engine oil.
	Fuel with low cetane number?	Use the specified fuel.
	Fuel leak due to loose injection pipe retaining nut?	Tighten nut.
	Incorrect injection timing?	Adjust.
	Fuel cam shaft worn?	Replace.
	Injection nozzle clogged?	Clean injection nozzle.
	Injection pump malfunctioning?	Repair or replace.
	Seizure of crankshaft, camshaft, piston, cylinder liner or bearing?	Repair or replace.
	Compression leak from cylinder?	Replace head gasket, tighten cylinder head bolt, glow plug and nozzle holder.
	Improper valve timing?	Correct or replace timing gear.
	Piston ring and liner worn?	Replace.
Excessive valve clearance?	Adjust.	

TABLE 17. ENGINE TROUBLESHOOTING (PART 2)

SYMPTOM	POSSIBLE PROBLEM	SOLUTION
Engine revolution is not smooth.	Fuel filter clogged or dirty?	Clean or change.
	Air cleaner clogged?	Clean or change.
	Fuel leak due to loose injection pipe retaining nut?	Tighten nut.
	Injection pump malfunctioning?	Repair or replace.
	Incorrect nozzle opening pressure?	Adjust.
	Injection nozzle stuck or clogged?	Repair or replace.
	Fuel over flow pipe clogged?	Clean.
	Governor malfunctioning?	Repair.
Either white or blue exhaust gas is observed.	Excessive engine oil?	Reduce to the specified level.
	Piston ring and liner worn or stuck?	Repair or replace.
	Incorrect injection timing?	Adjust.
	Deficient compression?	Adjust top clearance.
Either black or dark gray exhaust gas is observed.	Overload?	Lessen the load.
	Low grade fuel used?	Use the specified fuel.
	Fuel filter clogged?	Clean or change.
	Air cleaner clogged?	Clean or change.
	Deficient nozzle injection?	Repair or replace the nozzle.
Deficient output.	Incorrect injection timing?	Adjust.
	Engine's moving parts seem to be seizing?	Repair or replace.
	Uneven fuel injection?	Repair or replace the injection pump.
	Deficient nozzle injection?	Repair or replace the nozzle.
	Compression leak?	Replace head gasket, tighten cylinder head bolt, glow plug and nozzle holder.

DCA-40SSAI — TROUBLESHOOTING (GENERATOR/ENGINE)

TABLE 17. GENERATOR TROUBLESHOOTING

SYMPTOM	POSSIBLE PROBLEM	SOLUTION
No Voltage Output	AC Voltmeter defective?	Check output voltage using a voltmeter.
	Is wiring connection loose?	Check wiring and repair.
	Is AVR defective?	Replace if necessary.
	Defective Rotating Rectifier?	Check and replace.
Low Voltage Output	Is engine speed correct?	Turn engine throttle lever to "High".
	Is wiring connections loose?	Check wiring and repair.
	Defective AVR?	Replace if necessary.
High Voltage Output	Is wiring connections loose?	Check wiring and repair.
	Defective AVR?	Replace if necessary.
Circuit Breaker Tripped	Short Circuit in load?	Check load and repair.
	Over current?	Confirm load requirements and reduce.
	Defective circuit breaker?	Check and replace.
	Over current Relay actuated?	Confirm load requirement and replace.

EXPLANATION OF CODE IN REMARKS COLUMN

How to read the marks and remarks used in this parts book.

Items Found In the “Remarks” Column

Serial Numbers-Where indicated, this indicates a serial number range (inclusive) where a particular part is used.

Model Number-Where indicated, this shows that the corresponding part is utilized only with this specific model number or model number variant.

Items Found In the “Items Number” Column

All parts with same symbol in the number column, *, #, +, or %, belong to the same assembly or kit.

Note: If more than one of the same reference number is listed, the last one listed indicates newest (or latest) part available.

DCA-40SSAI W/ISUZU 4BD1 DIESEL ENGINE 1 TO 3 UNITS

<u>Qty.</u>	<u>P/N</u>	<u>Description</u>
1	0601808811	CIRCUIT BREAKER
1	0601820671	AUTOMATIC VOLTAGE REGULATOR
1	0601840073	RHEOSTAT VOLTAGE REGULATOR
1	0601840121	KNOB RHEOSTAT
1	M1310500403	RADIATOR HOSE
1	M1310500303	RADIATOR HOSE
1	8941324900	RADIATOR HOSE
5	8943212191	OIL FILTER
5	X132400240	FUEL FILTER
5	0602046368	AIR ELEMENT
1	0602122272	UNIT, OIL PRESSURE
1	0602123260	UNIT WATER TEMPERATURE
1	0601810245	BULB, ALARM LAMP
1	8970208220	FAN BELT
1	1823100080	STARTER SWITCH
3	KEYISUZUF	KEY, STARTER SWITCH

NOTE

Part number on this Suggested Spare Parts list may supercede/replace the P/N shown in the text pages of this book.

DCA-40SSAI --- GENERATOR ASSY.

GENERATOR ASSY.

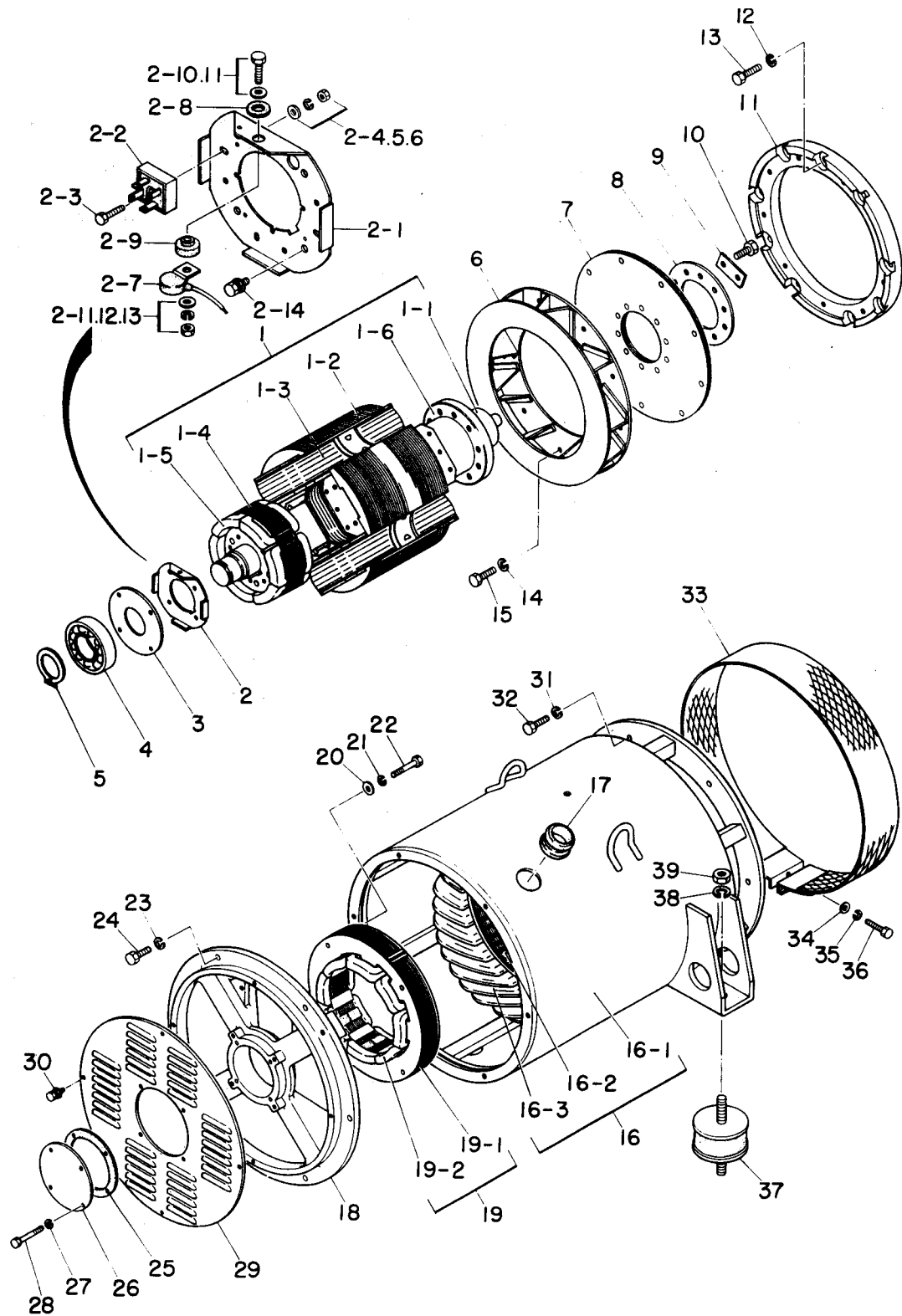

DCA-40SSAI --- GENERATOR ASSY.

GENERATOR ASSY.

<u>NO.</u>	<u>PART NO.</u>	<u>ITEM</u>	<u>QTY.</u>	<u>REMARKS</u>
1	3341040300	FIELD ASSY.	1	
1-1	3341010102	SHAFT	1	
1-2	9521002693	FIELD CORE	1	
1-3	3341080003	FIELD COIL	1	
1-4	3361032003	ARMATURE CORE, EXCITER	1	
1-5	33610850003	ARMATURE COIL, EXCITER	1	
1-6	334110003	COUPLING HUB	1	
2	3361025003	RECTIFIER ASSY.	1	
2-1	3361026003	SET PLATE, RECTIFIER	1	
2-2	0601820067	RECTIFIER	3	PB2510
2-3	0010004020	HEX. HEAD BOLT	3	
2-4	0041604000	PLAIN WASHER	6	
2-5	0040004000	LOCK WASHER	3	
2-6	OEMAA8	HEX. NUT	3	REPLACES 0030004000
2-7	0601822601	SURGE ABSORBER	1	ERZM14K621A
2-8	0801841004	INSULATOR WASHER	1	
2-9	0801841104	INSULATOR WASHER	1	
2-10	0017105020	HEX. HEAD BOLT	1	REPLACES 0010005020
2-11	58151	PLAIN WASHER	2	REPLACES 0041605000
2-12	0032005000	LOCK WASHER.....	1	REPLACES 0040005000
2-13	0030005000	HEX. NUT	1	
2-14	0011305100	HEX. HEAD BOLT	4	REPLACES 0017105012
3	3331014004	BEARING FLANGE	1	
4	0070206310	BEARING	1	
5	0080000050	SNAP RING	1	
6	3341070002	FAN	1	
7	3341611003	COUPLING DISK	1(8)	
8	3341612003	WASHER, COUPLING HUB	1	
9	3341613004	LOCK WASHER	5	
10	0131151240	HEX. HEAD BOLT	10	REPLACES 0010312030
11	0601600000	COUPLING RING	1	9261290050
12	030212300	LOCK WASHER.....	9	REPLACES 0601610700 & 9091505100
13	0601610511	BOLT SET	1	
14	0040010000	LOCK WASHER	9	
15	012010030	HEX. HEAD BOLT	9	REPLACES 0010310030
16	3341341400	STATOR ASSY.	1	
16-1	3341320312	GENERATOR FRAME	1	
16-2	3801342114	ARMATURE CORE	1	
16-3	3341361503	ARMATURE COIL	1	
17	0801350104	GROMMET	1	
18	3361315013	END BRACKET	1	
19	3361350030	FIELD ASSY. EXCITER	1	
19-1	3361352023	FIELD CORE, EXCITER	1	
19-2	3361362303	FIELD COIL, EXCITER	1	

DCA-40SSAI --- GENERATOR ASSY.

GENERATOR ASSY.

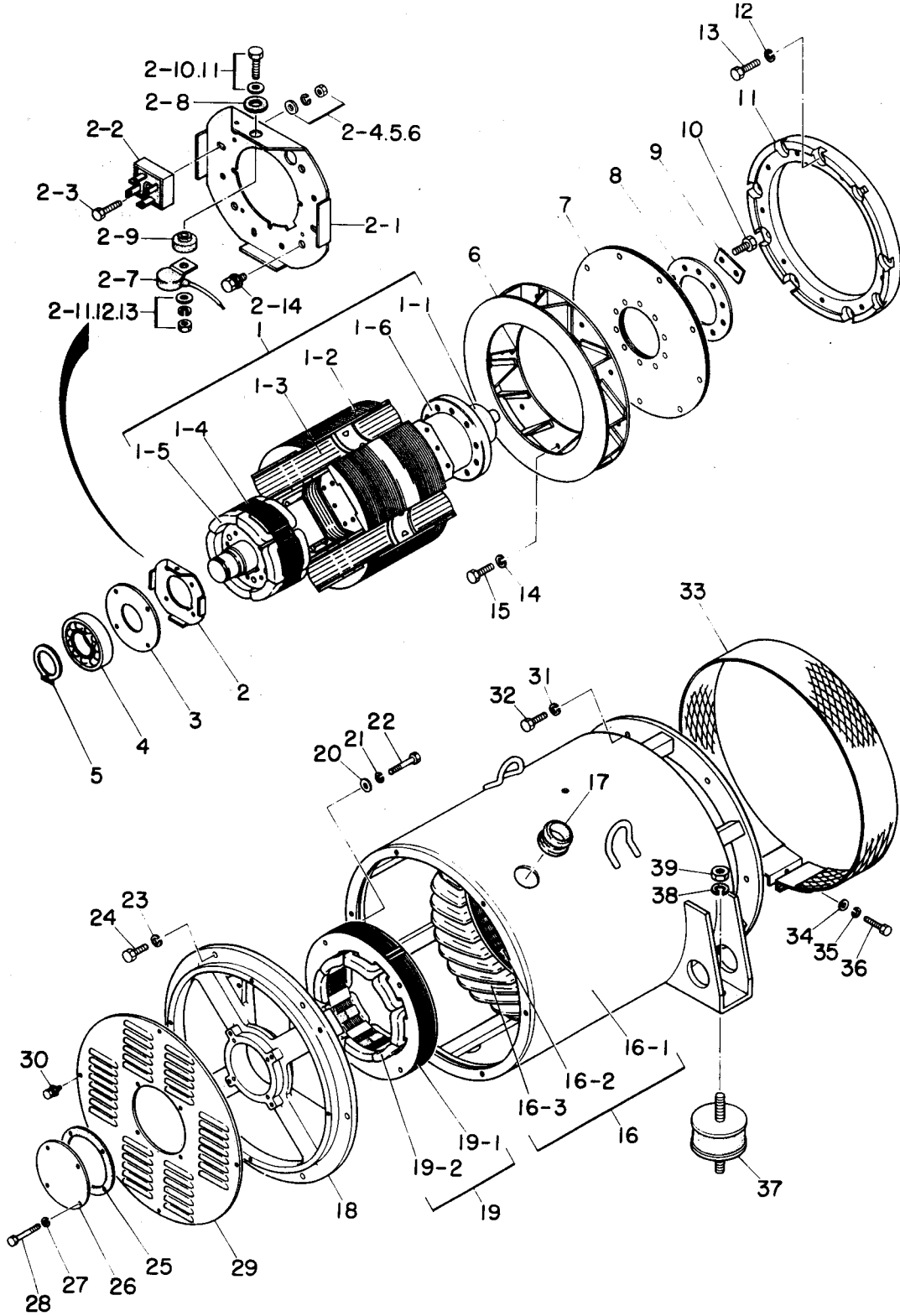

DCA-40SSAI --- GENERATOR ASSY.

GENERATOR ASSY.

<u>NO.</u>	<u>PART NO.</u>	<u>ITEM</u>	<u>QTY.</u>	<u>REMARKS</u>
20	031108160	PLAIN WASHER	4	REPLACES 0041608000
21	0040008000	LOCK WASHER	4	
22	0010008060	HEX. HEAD BOLT	4	
23	0040010000	LOCK WASHER	6	
24	012010030	HEX. HEAD BOLT	6	REPLACES 0010010030
25	3801312004	GASKET, BEARING	1	
26	3331310104	COVER, BEARING	1	
27	0040006000	LOCK WASHER	4	
28	0040006055	HEX. HEAD BOLT	4	
29	3361331003	COVER, END BRACKET	1	
30	011006010	HEX. HEAD BOLT	8	REPLACES 0017106010
31	0040010000	LOCK WASHER	6	
32	0105091025	HEX. HEAD BOLT	6	REPLACES 0010310025
33	3361332003	COVER, FAN	1	
34	952404470	PLAIN WASHER	1	REPLACES 0041606000
35	0040006000	LOCK WASHER	1	
36	0010006030	HEX. HEAD BOLT	1	
37	0605000011	RUBBER SUSPENSION	2	
38	0040016000	LOCK WASHER	4	
39	020316130	HEX. NUT	4	REPLACES 0030116000

DCA-40SSAI --- CONTROL BOX ASSY.

CONTROL BOX ASSY.

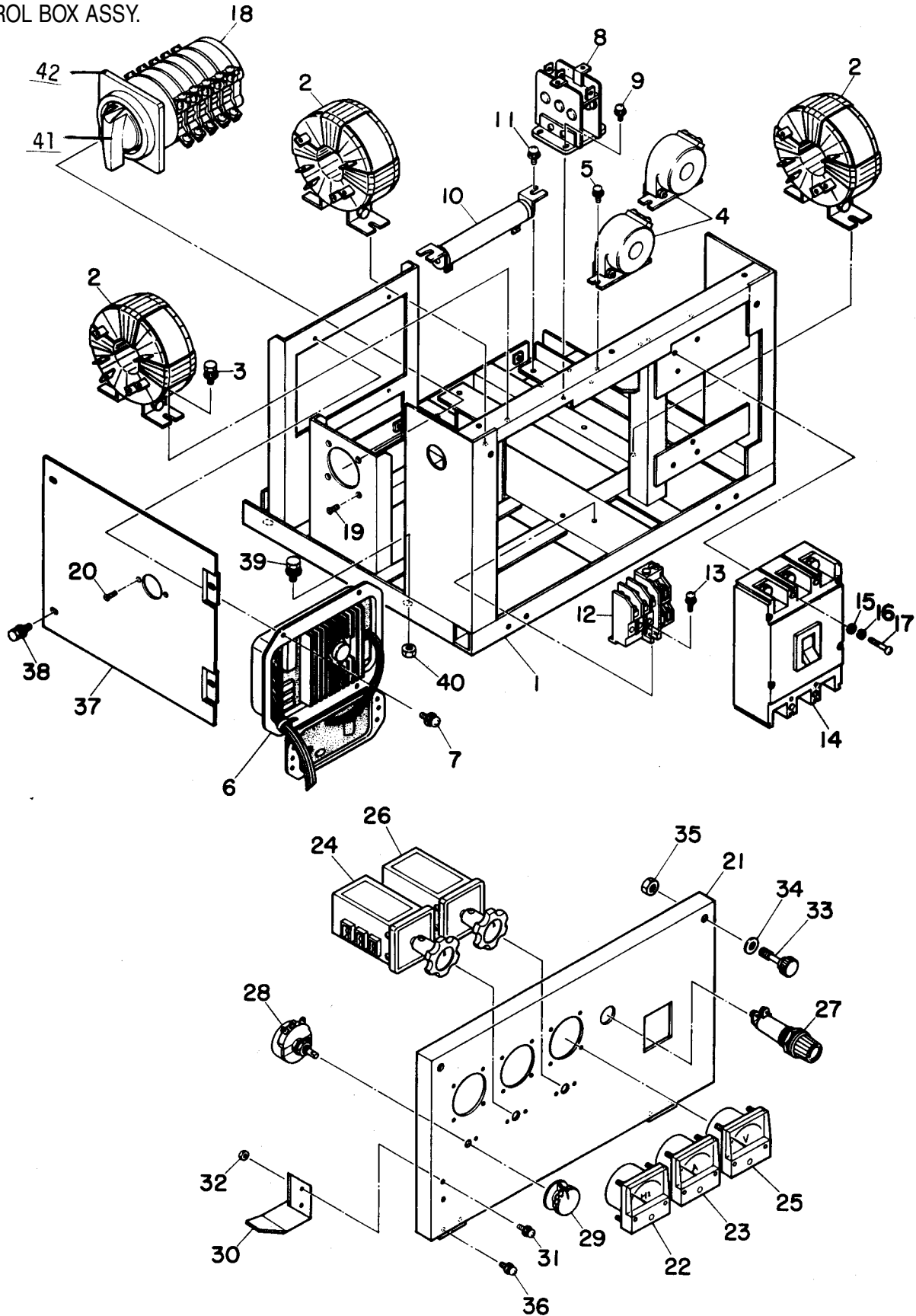

DCA-40SSAI --- CONTROL BOX ASSY.

CONTROL BOX ASSY.

<u>NO.</u>	<u>PART NO.</u>	<u>ITEM</u>	<u>QTY.</u>	<u>REMARKS</u>
1	7451810002	CONTROL BOX	1	UP TO S/N3311949
	7451810012	CONTROL BOX	1	S/N3311950
2	3361870603	CURRENT TRANSFORMER	3	
3	0017106016	HEX.HEAD BOLT	6	
4	0601801142	CURRENT TRANSFORMER, AMMETER	2	CT3.5MR 75/5A
5	0027104010	MACHINE SCREW	4	
6	0800225200	AUTOMATIC VOLTAGE REGULATOR	1	AE2206A
7	0027106010	MACHINE SCREW	6	
8	0601820042	RECTIFER	1	
9	0027103010	MACHINE SCREW	4	
10	0601842058	RESISTOR	1	80V 200OHMS
11	0027108010	MACHINE SCREW	2	
14	0601804970	CIRCUIT BREAKER	1	TO100CC 500V 100AT
15	0041604000	PLAIN WASHER	2	
16	0040004000	LOCK WASHER	2	
17	0021004060	MACHINE SCREW	2	
18	0601830625	CHANGE-OVER SW. VOLTAGE	1	
19	0021104016	MACHINE SCREW	4	
20	0021104014	MACHINE SCREW	2	
21	3341822503	CONTROL PANEL	1	
22	0601800460	FREQUENCY METER	1	PAK60 220V 45~65Hz
23	0601800729	AC AMMETER	1	PSK60 0~75A 0~150A
24	0601801040	CHANGE-OVER SW. AMMETER	1	SL2AS
25	0601800212	AC VOLTMETER	1	PCK60 0~600V; REPLACES
	0601800217			
26	0601801041	CHANGE-OVER SW. VOLTMETER	1	SL2VS
27	0601810072	PILOT LAMP	1	
	0601810261	BULB	1	
28	0601840031	VOLTAGE REGULATOR	1	RA30A2FE202BJ
29	0601840120	KNOB	1	
30	3331824003	STOPPER, CONTROL PANEL	1	
31	0027105016	MACHINE SCREW	2	
32	0030005000	HEX. NUT	2	
33	0805001304	SET SCREW, CONTROL PANEL	2	
34	031108160	PLAIN WASHER	2	REPLACES 0041608000
35	020108060	HEX. NUT	2	REPLACES 0030008000
36	0027105010	MACHINE SCREW	4	
37	7451826504	SIDE PANEL, CONTROL BOX	1	UP TO S/N3311949
	7451826514	SIDE PANEL, CONTROL BOX	1	S/N3311950~
38	0017106016	HEX. HEAD BOLT	2	
39	011008020	HEX. HEAD BOLT	4	REPLACES 0017108020
40	020108060	HEX. NUT	4	REPLACES 0030008000
41	0601840191	SWITCH CAP	1	
42	0601830614	PLATE	1	

DCA-40SSAI ENGINE AND RADIATOR ASSY.

ENGINE AND RADIATOR ASSY.

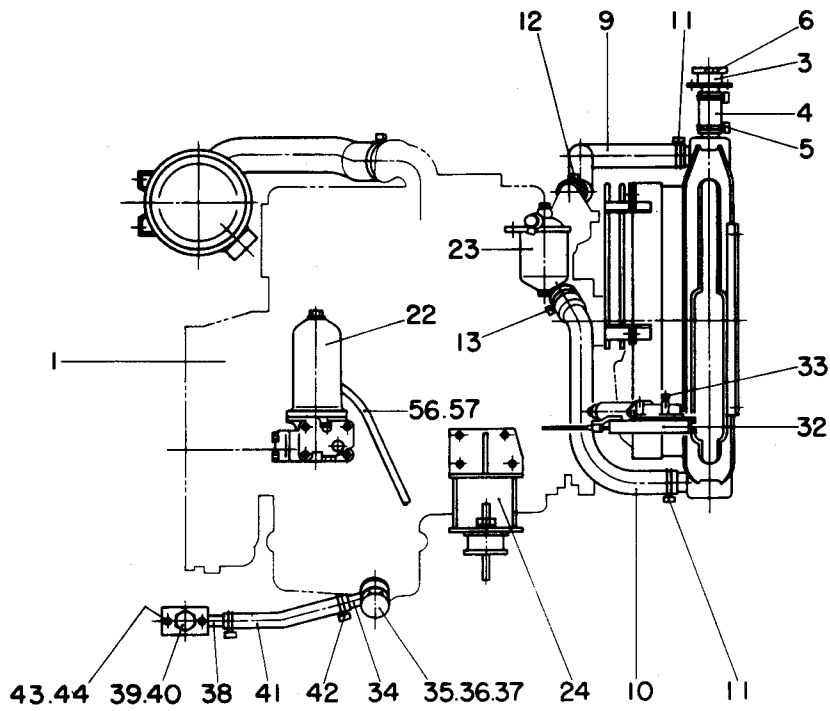
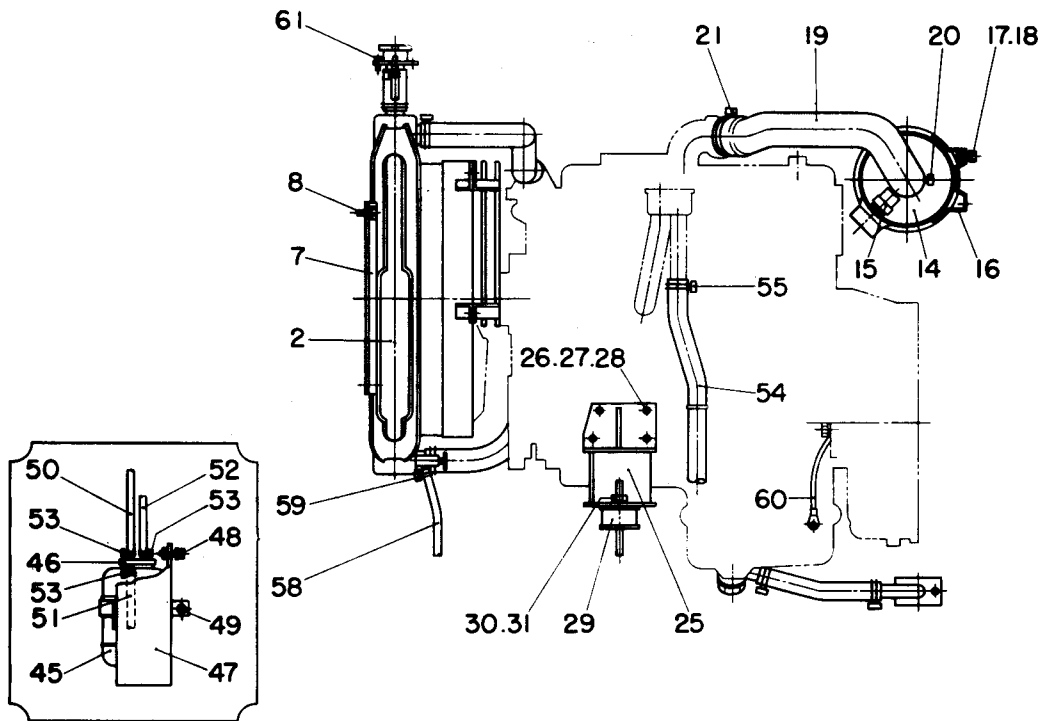

DCA-40SSAI ENGINE AND RADIATOR ASSY.

ENGINE AND RADIATOR ASSY.

<u>NO.</u>	<u>PART NO.</u>	<u>ITEM</u>	<u>QTY.</u>	<u>REMARKS</u>
1	4B01PD02	ENGINE	1	ISUZU 4BD1; REPLACES 0602000078
2	0602010800	RADIATOR	1	B961110002
3	0602011303	RADIATOR NECK	1	4079111300
4	0602011102	HOSE	1	B9611111910
5	0602014062	HOSE BAND	2	G000100131
6	0602011000	RADIATOR CA	1	7880K11100
7	3345123104	BRACKET, RADIATOR	2	
8	011008020	HEX. HEAD BOLT	12	REPLACES 0017108020
9	0602013086	RADIATOR HOSE	1	4B128
10	0602013186	RADIATOR HOSE	1	4B129
11	0602014000	HOSE BAND	2	
12	0602014000	HOSE BAND	1	
13	0602014071	HOSE BAND	1	
14	0602040094	AIR CLEANER	1	FQG068002
	0602040197	ELEMENT, AIR CLEANER	1	P104873
15	0602040690	DUST INDICATOR	1	RBX002252
16	0602040595	BAND, AIR CLEANER	2	P007191
17	011008020	HEX. HEAD BOLT	4	REPLACES 0017108020
18	020108060	HEX. NUT	4	REPLACES 0030008000
19	3342032103	HOSE, AIR CLEANER	1	
20	0605515011	HOSE BAND	1	
21	0605515028	HOSE BAND	1	
22	1878102201	ELEMENT, OIL FILTER	1	REPLACES 0602041107
23	5878100500	ELEMENT, FUEL FILTER	1	REPLACES 0602042108
24	3345112503	ENGINE FOOT	1	
25	3345112403	ENGINE FOOT	1	
26	031110160	PLAIN WASHER	8	REPLACES 0041610000
27	0040010000	LOCK WASHER	8	
28	0105091025	HEX. HEAD BOLT	8	REPLACES 0010710025
29	0605000009	RUBBER SUSPENSION	2	
30	0040012000	LOCK WASHER	4	
31	0039312000	HEX. NUT	4	REPLACES 0030112000
32	1819001931	ENGINE STOPPER	1	REPLACES 0602210803 AND 1819000161
33	0027106016	MACHINE SCREW	3	

DCA-40SSAI ENGINE AND RADIATOR ASSY.

ENGINE AND RADIATOR ASSY.

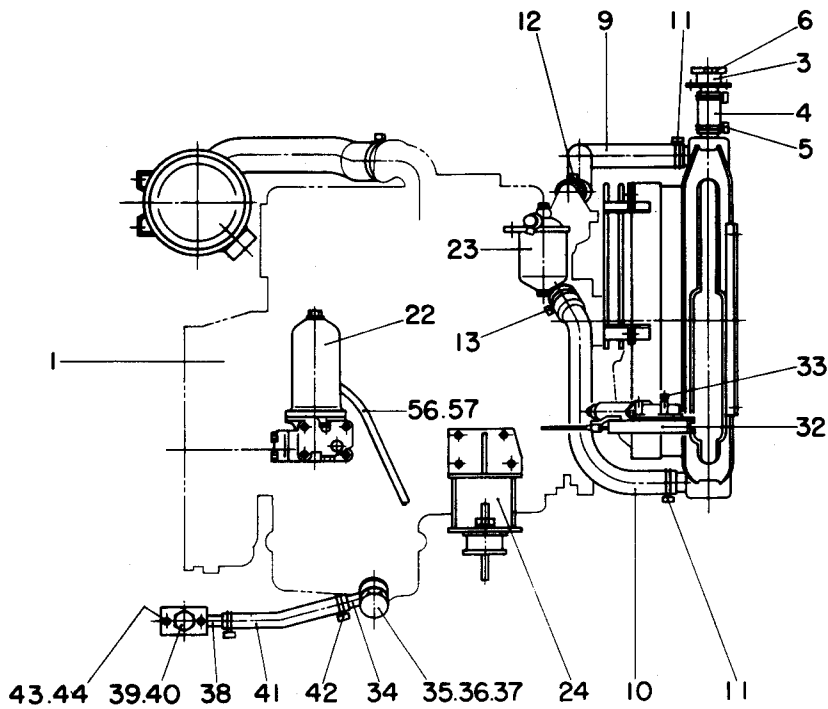
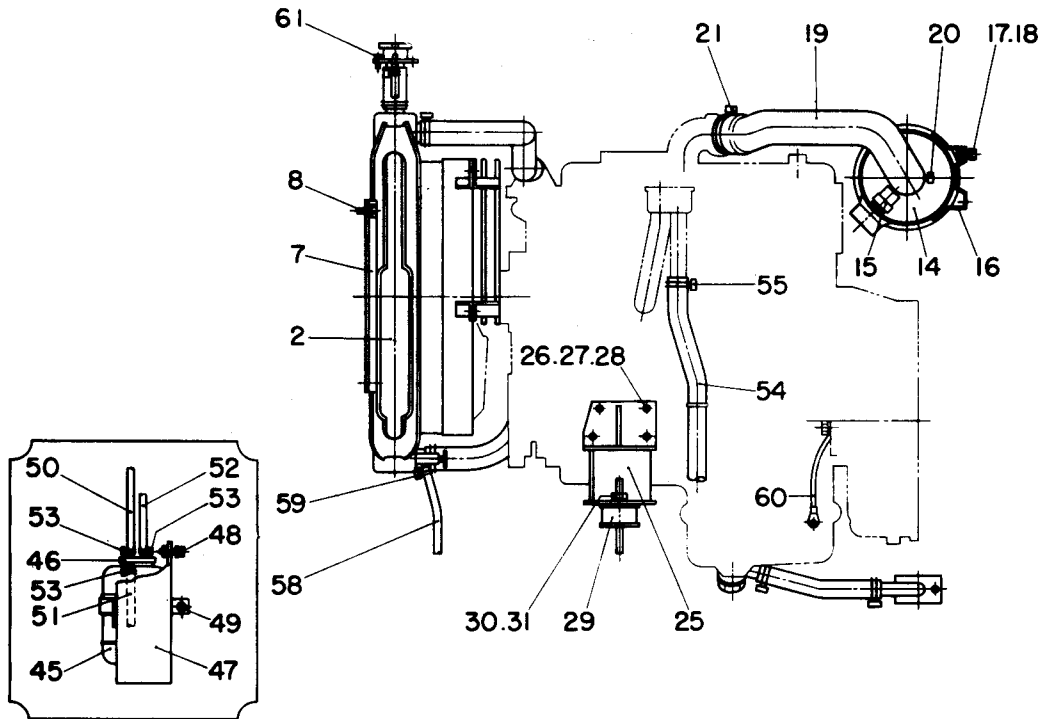

DCA-40SSAI ENGINE AND RADIATOR ASSY.

ENGINE AND RADIATOR ASSY.

<u>NO.</u>	<u>PART NO.</u>	<u>ITEM</u>	<u>QTY.</u>	<u>REMARKS</u>
34	3342054104	DRAIN JOINT	1	
35	0805013704	PACKING, OIL PAN SIDE	1	
36	0805014204	PACKING	1	
37	3362054104	JOINT BOLT	1	
38	3342051104	DRAIN JOINT	1	
39	0802024004	PACKING	1	
40	0802010204	PLUG	1	
41	3342022104	DRAIN HOSE	1	
42	0605515003	HOSE BAND	2	
43	011008020	HEX. HEAD BOLT	2	REPLACES 0017108020
44	020108060	HEX. NUT	2	REPLACES 0030008000
45	0845031303	RESERVE TANK	1	
46	0802081104	CAP, RESERVE TANK	1	
47	3342082304	BRACKET, RESERVE TANK	1	
48	011008020	HEX. HEAD BOLT	2	REPLACES 0017108020
49	011606025	HEX. HEAD BOLT	1	REPLACES 0017106025
50	0199500950	HOSE	1	
51	0199500175	HOSE	1	
52	0193601000	HOSE	1	
53	0605515013	HOSE	1	
53	0605515013	HOSE BAND	4	
54	0193900750	BREATHER HOSE	1	
55	0605515030	HOSE BAND	2	
56	0193100700	HOSE	1	
57	0605515007	HOSE BAND	1	
58	0193800750	HOSE	1	
59	0605515019	HOSE BAND	1	
60	3342220604	EARTH CABLE	1	
61	0017106016	HEX. HEAD BOLT	4	

DCA-40SSAI --- ENGINE OPERATING PANEL ASSY.

ENGINE OPERATING PANEL ASSY.

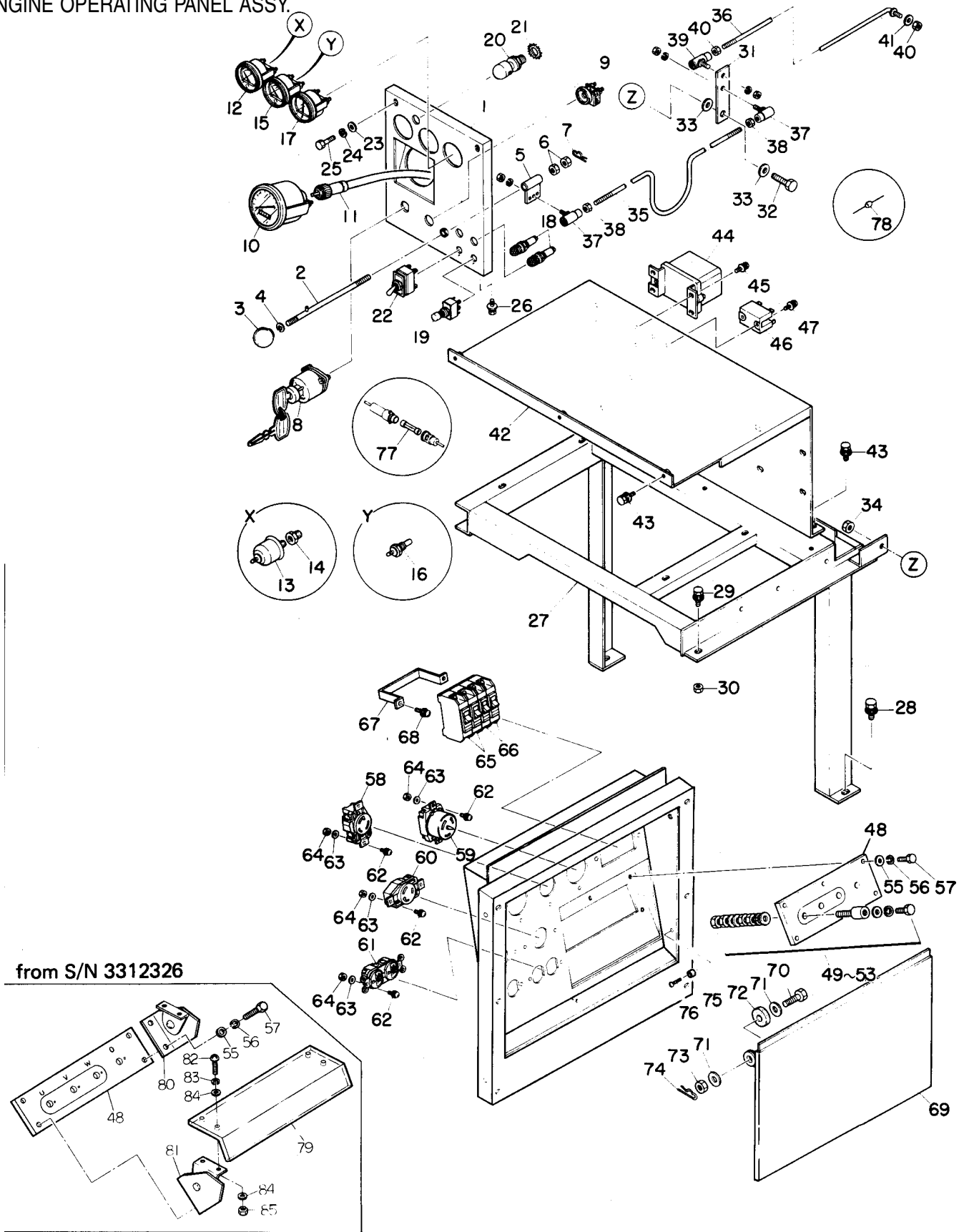

DCA-40SSAI --- ENGINE OPERATING PANEL ASSY.

ENGINE OPERATING PANEL ASSY.

<u>NO.</u>	<u>PART NO.</u>	<u>ITEM</u>	<u>QTY.</u>	<u>REMARKS</u>
1	3342101003	OPERATING PANEL	1	
2	7452142004	SLIDE BAR	1	
3	0601840190	KNOB	1	REPLACES 0805012904
4	0080200006	SNAP RING	1	
5	7452140504	BRACKET, GOVERNOR ROD	1	
6	020108060	HEX. NUT	2	REPLACES 0030008000
7	0605010503	SNAP PIN	1	
8	1823100080	STARTER SWITCH	1	REPLACES 0602100004
9	9825300460	PREHEAT LAMP	1	REPLACES 0602102006 AND 9825301080
10	0602120052	TACHOMETER	1	25000KX3710; REPLACES 0602120052
11	0602120154	CABLE, TACHOMETER	1	62100KA6710 L=1150
12	0602122060	OIL PRESSURE GAUGE	1	42000KX1410
13	0602122200	UNIT, OIL PRESSURE	1	53000AC0101
14	0131300000	STREET SOCKET	1	
15	0602123061	WATER TEMPERATURE GAUGE .	1	40000KX0910
16	0602123201	UNIT, WATER TEMPERATURE	1	51400KV0200
17	0602121052	CHARGE AMMETER	1	43000KV0300
18	0602103091	ALARM LAMP	2	REPLACES 0602103060
	0601810244	BULB	2	
19	0601830420	SWITCH, LAMP CHECK	1	
20	0601810120	PANEL LIGHT	1	
21	0040520000	TOOTHED LOCK WASHER	1	
22	0601830710	SWITCH, PANEL LIGHT	1	
23	031108160	PLAIN WASHER	2	REPLACES 0041608000
24	0040008000	LOCK WASHER	2	
25	011008040	HEX. HEAD BOLT	2	REPLACES 0010008040
26	011008020	HEX. HEAD BOLT	2	REPLACES 0017108020
27	3345312003	SUPPORT LEG	1	
28	0017110025	HEX. HEAD BOLT	2	
29	011208025	HEX. HEAD BOLT	2	REPLACES 0017108025
30	0030008000	HEX. NUT	2	
31	3342183004	LINK, GOVERNOR ROD	1	
32	0010010025	HEX. HEAD BOLT	1	
33	031110160	PLAIN WASHER	2	REPLACES 0041610000
34	020310080	HEX. NUT	1	REPLACES 0030010000
35	3342182004	GOVERNOR ROD	1	
36	3342152114	GOVERNOR ROD	1	
37	0602180101	BALL JOINT	2	
38	020108060	HEX. NUT	2	REPLACES 0030008000
39	0602180100	BALL JOINT	1	
40	020106050	HEX. NUT	3	REPLACES 0030006000
41	952404470	PLAIN WASHER	1	REPLACES 0041606000

DCA-40SSAI --- ENGINE OPERATING PANEL ASSY.

ENGINE OPERATING PANEL ASSY.

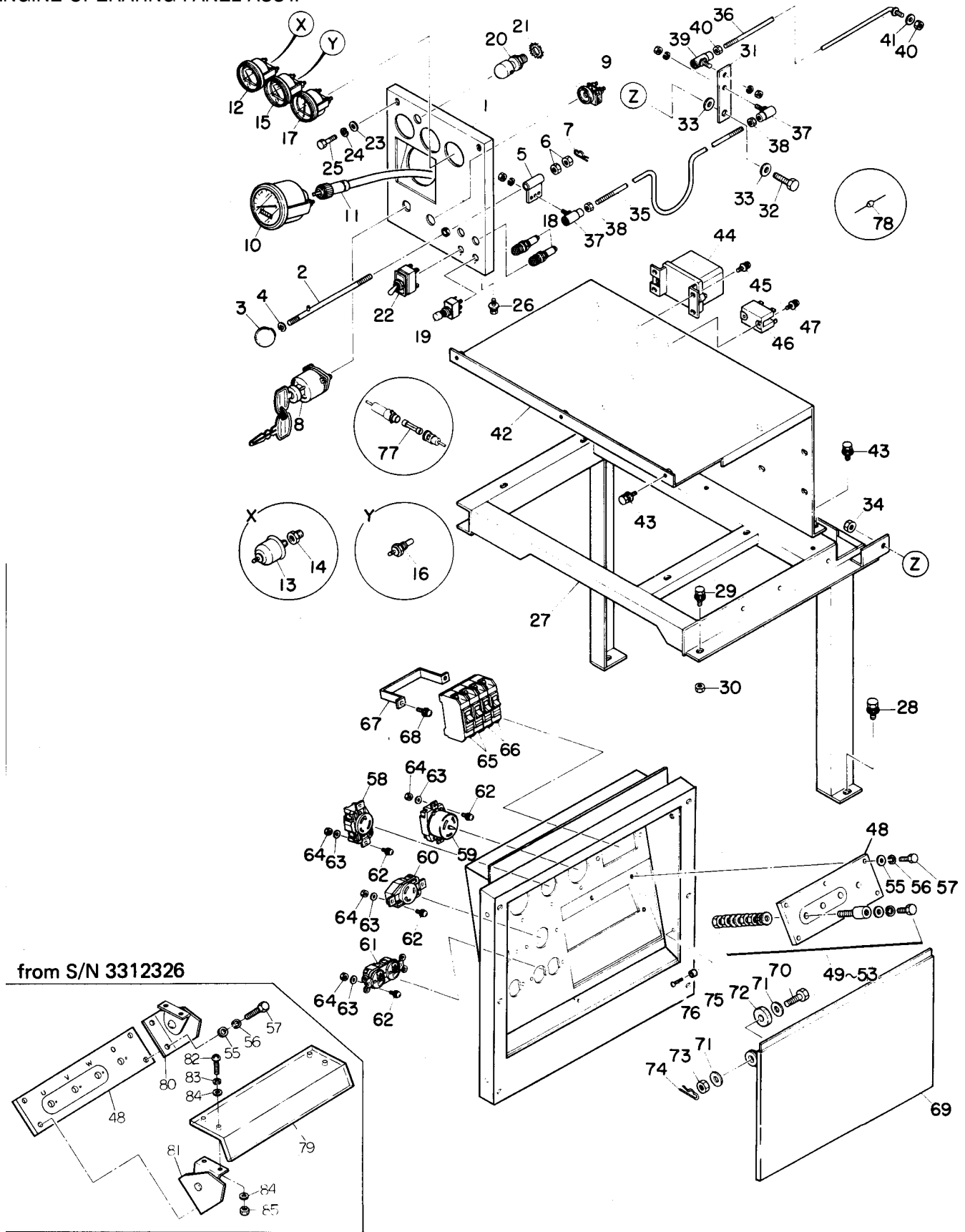

DCA-40SSAI --- ENGINE OPERATING PANEL ASSY.

ENGINE OPERATING PANEL ASSY.

<u>NO.</u>	<u>PART NO.</u>	<u>ITEM</u>	<u>QTY.</u>	<u>REMARKS</u>
42	3345188203	SET PANEL, ELECTRIC PARTS	1	
43	011008020	HEX. HEAD BOLT	6	REPLACES 0017108020
44	1825500732	EMERGENCY RELAY	1	REPLACES 0602200405
45	0027106016	MACHINE SCREW	4	
46	0601823706	RELAY	1	
47	0027104016	MACHINE SCREW	2	
48	3341860103	SET BOARD, OUTPUT TERMINAL	1	
49	0801831704A	OUTPUT TERMINAL	4	
50	012210020	HEX. HEAD BOLT	4	REPLACES 0801831804
51	0041410000	PLAIN WASHER	16	
52	0040010000	LOCK WASHER	12	
53	0039310000	HEX. NUT	8	
55	031108160	PLAIN WASHER	5	REPLACES 0041608000
56	0040008000	LOCK WASHER	5	
57	011208030	HEX. HEAD BOLT	5	REPLACES 0010008030
58	0601811032	RECEPTACLE	2	L620R 250V 20A
59	0601811037	RECEPTACLE	2	CS8269 250V 50A
60	0601811031	RECEPTACLE	2	L530R 125V 30A
61	0601811030	RECEPTACLE	2	520R 125V 20Ax2
62	0027103010	MACHINE SCREW	16	
63	0041603000	PLAIN WSAHER	16	
64	0207003000	HEX. NUT	16	REPLACES 0030003000
65	0601805311	CIRCUIT BREAKER	2	KM51 265V 50A
66	0601805315	CIRCUIT BREAKER	2	KM51 265V 30A
67	7451816004	BRACKET, CIRCUIT BREAKER	1	
68	0027106016	MACHINE SCREW	2	
69	3341865803	COVER, OUTPUT TERMINAL	1	
70	0805012304	HEX. HEAD BOLT	2	
71	031112230	PLAIN WASHER	4	REPLACES 0041612000
72	0805019704	RUBBER WASHER	2	
73	0030012000	HEX. NUT	2	
74	0605010505	SNAP PIN	2	
75	0601850091	RUBBER CUSHION	2	
76	0021003010	MACHINE SCREW	2	
77	0601802133	FUSE, 5A	1	
78	0601820015	RECTIFIER	4	1S2762
79	3341865903	COVER, OUPUT TERMINAL	1	S/N3312326~
80	7451855503	HING	1	S/N3312326~
81	7451855703	HINGE	1	S/N3312326~
82	0021304015	MACHINE SCREW	4	S/N3312326~
83	0040004000	LOCK WASHER	4	S/N3312326~
84	031104080	PLAIN WASHER	8	S/N3312326~; REPLACES 0041204000
85	OEMAA8	HEX. NUT	4	S/N3312326~; REPLACES 0030104000

DCA-40SSAI --- BATTERY ASSY.

BATTERY ASSY.

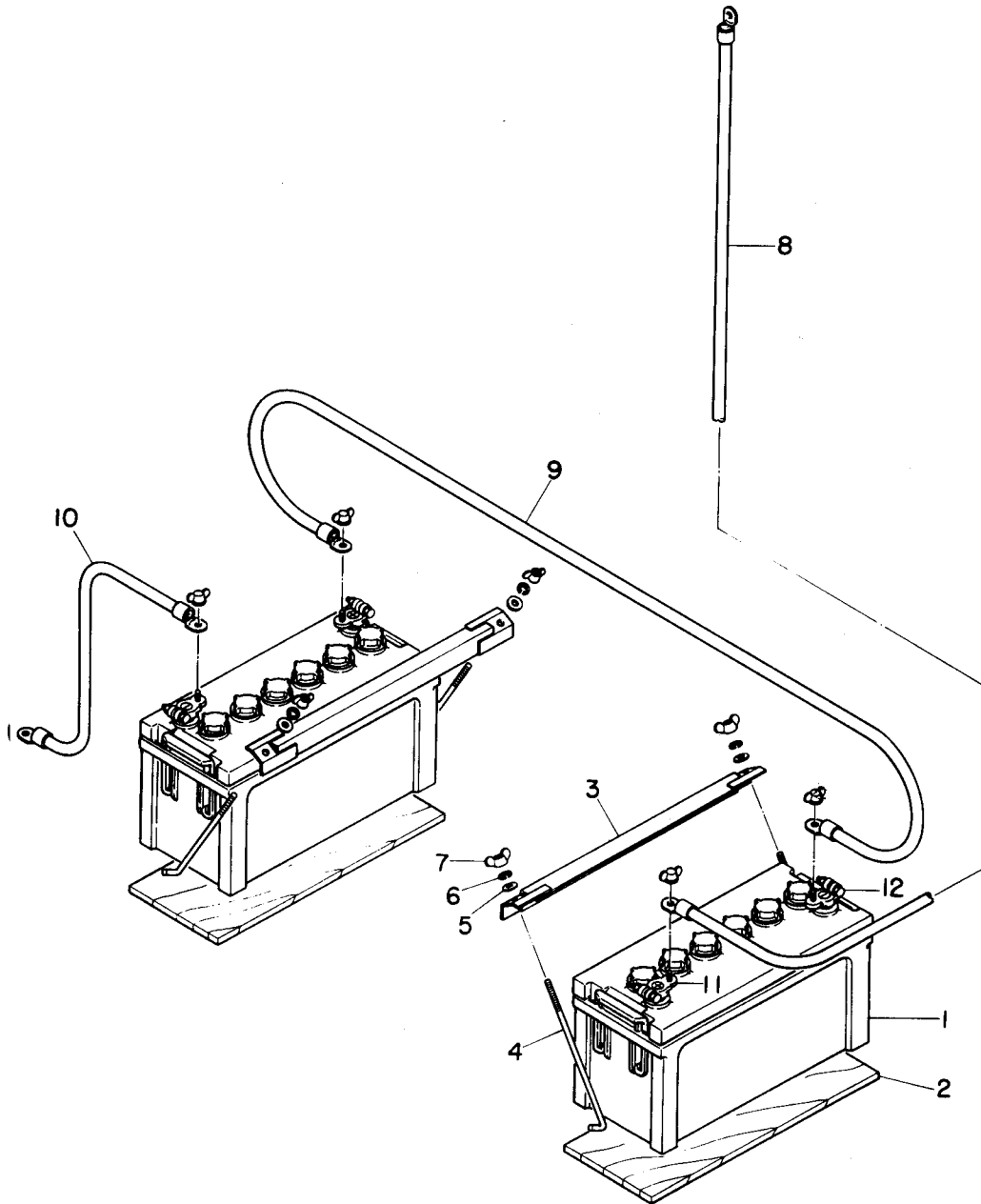

DCA-40SSAI --- BATTERY ASSY.

BATTERY ASSY.

<u>NO.</u>	<u>PART NO.</u>	<u>ITEM</u>	<u>QTY.</u>	<u>REMARKS</u>
1	0160012100	BATTERY	2	N100 12V 100Ah
2	0805003904	BATTERY SHEET	2	
3	0805004004	BATTERY BAND	2	
4	3802252004	BATTERY BOLT	4	
5	0041608000	PLAIN WASHER	4	
6	031108160	LOCK WASHER	4	REPLACES 0040008000
7	0037808000	WING NUT	4	
8	0215260050	BATTERY CABLE	1	
9	0211160160	BATTERY CABLE	1	
10	0215860045	BATTERY CABLE	1	
11	0602220310	TERMINAL ASSY. (+)	2	NO.9P
	0037808000	WING NUT	2	REPLACES 0208008000
12	0602220311	TERMINAL ASSY. (-)	2	NO.9N
	0037808000	WING NUT	2	REPLACES 0208008000

DCA-40SSAI --- MUFFLER ASSY.

MUFFLER ASSY.

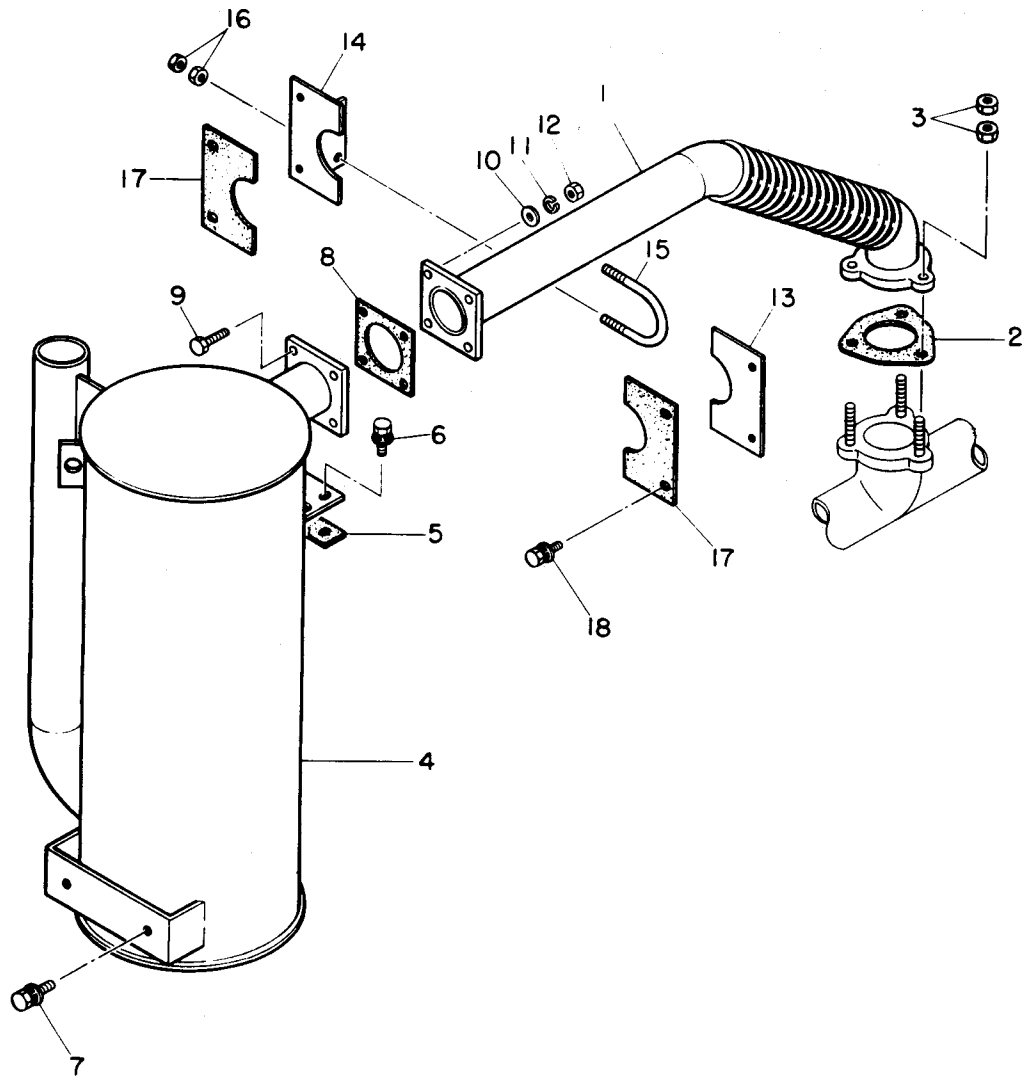

DCA-40SSAI --- MUFFLER ASSY.

MUFFLER ASSY.

<u>NO.</u>	<u>PART NO.</u>	<u>ITEM</u>	<u>QTY.</u>	<u>REMARKS</u>
1	3342350103	EXHAUST PIPE	1	
2	1141450690	GASKET	1	REPLACES 0602320000 AND 9221160010
3	9091103100	HEX. NUT	6	REPLACES 0602323002
4	3342311102	MUFFLER	1	
5	3342359104	MUFFLER SHEET	1	
6	011208025	HEX. HEAD BOLT	2	REPLACES 0017108025
7	012210020	HEX.HEAD BOLT	2	REPLACES 0017110020
8	3342356104	GASKET	1	
9	011008035	HEX. HEAD BOLT	4	REPLACES 0010108035
10	031108160	PLAIN WASHER	4	REPLACES 0041608000
11	0040008000	LOCK WASHER	4	
12	020108060	HEX. NUT	4	REPLACES 0030008000
13	3342354104	COVER	1	
14	3342354004	COVER	1	
15	3342328104	PIPE CLAMPER	1	
16	020108060	HEX. NUT	4	REPLACES 0030008000
17	3342359004	COVER SHEET	2	
18	0112508025	HEX. HEAD BOLT	4	REPLACES 0017108025

DCA-40SSAI --- FUEL TANK ASSY.

FUEL TANK ASSY.

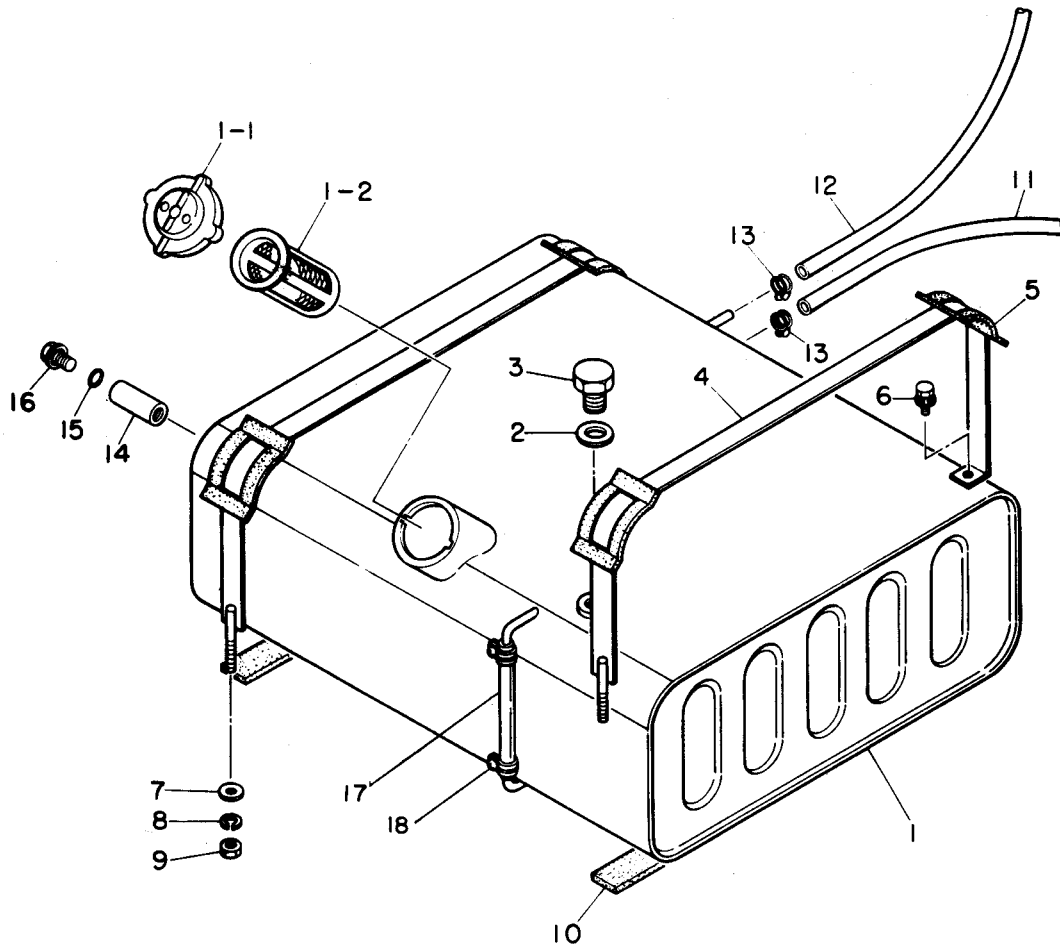

FUEL TANK ASSY.

<u>NO.</u>	<u>PART NO.</u>	<u>ITEM</u>	<u>QTY.</u>	<u>REMARKS</u>
1	3345510323	FUEL TANK	1	
1-1	0810105004	CAP, FUEL TANK	1	
1-2	0810105400	FUEL FILTER	1	
2	0802010304	PACKING	1	
3	0602021042	PLUG	1	960922101
4	3345523304	TANK BAND	2	
5	0805003404	PAD, TANK BAND	4	
6	011008020	HEX. HEAD BOLT	2	REPLACES 0017108020
7	031108160	PLAIN WASHER	2	REPLACES 0041608000
8	0040008000	LOCK WASHER	2	
9	020108060	HEX. NUT	2	REPLACES 0030008000
10	3805522004	TANK SHEET	4	
11	0191300600	SUCTION HOSE	1	
12	0191300700	RETURN HOSE	1	
13	0605515014	HOSE BAND	4	
14	0845032204	DRAIN JOINT	1	
15	0150000018	O RING	1	
16	0802011104	PLUG	1	
17	0193100225	FUEL GAUGE HOSE	1	
18	0605515079	HOSE BAND	2	

DCA-40SSAI --- ENCLOSURE ASSY.

ENCLOSURE ASSY.

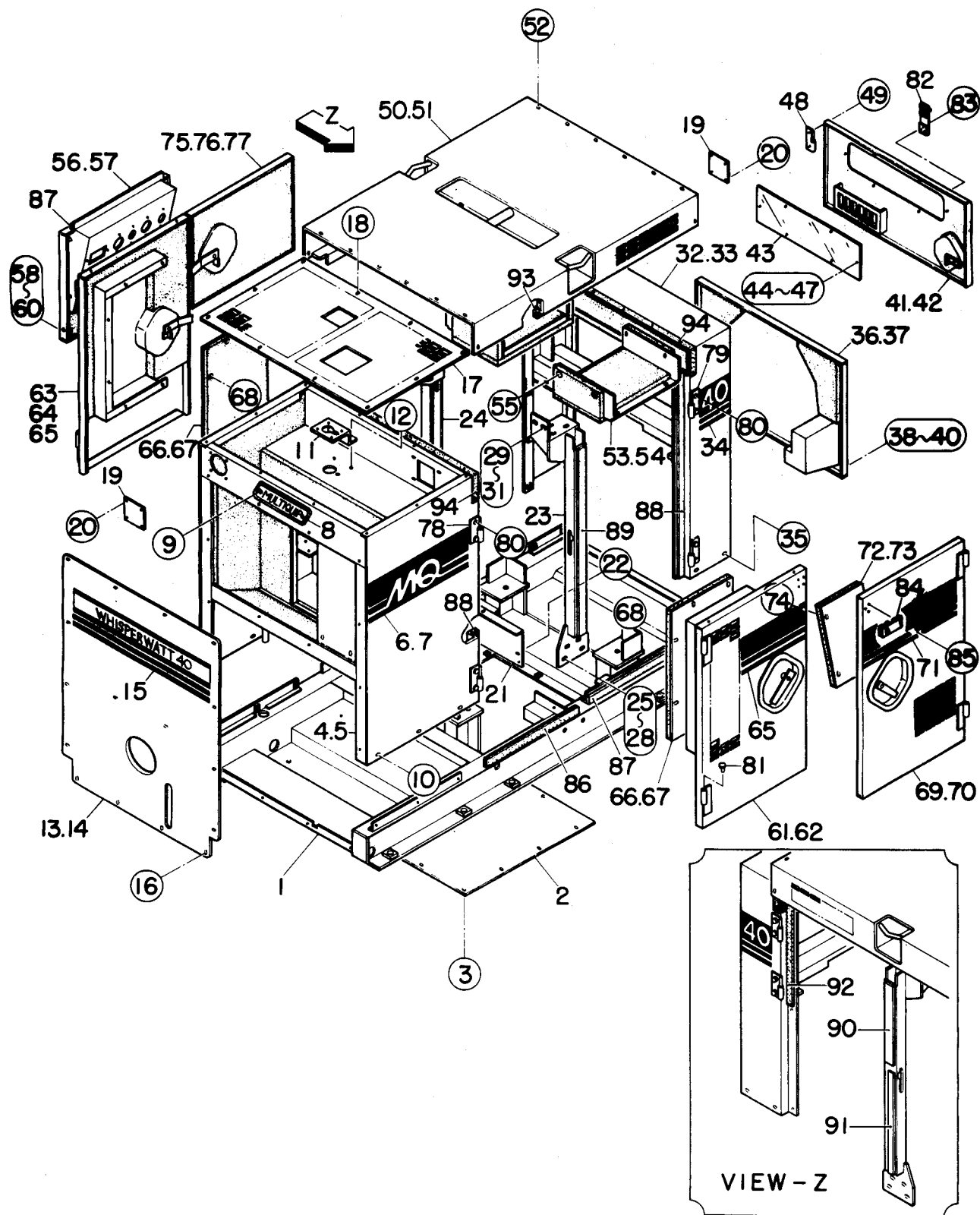

DCA-40SSAI --- ENCLOSURE ASSY.

ENCLOSURE ASSY.

<u>NO.</u>	<u>PART NO.</u>	<u>ITEM</u>	<u>QTY.</u>	<u>REMARKS</u>
1	3345111322	BASE	1	
2	3345116214	FLOOR PANEL	1	
3	011008020	HEX. HEAD BOLT	10	REPLACES 0017108020
4	3345121122	FRONT FRAME	1	
5	3345109103	LINING	1	
6	B3561100103	STRIPE, LEFT SIDE	1	REPLACES 3340630303
7	3340630503	STRIPE, RIGHT SIDE	1	
8	0600500090	EMBLEM.....	2	REPLACES 6360510003
9	0021106020	MACHINE SCREW	4	
10	011008020	HEX. HEAD BOLT	6	REPLACES 0017108020
11	3345122604	BRACKET, RADIATOR NECK	1	
12	011008020	HEX. HEAD BOLT	2	REPLACES 0017108020
13	3345125103	COVER, FRONT FRAME	1	
14	3345109204	LINING	1	
15	B3561100003	STRIPE	1	REPLACES 3340630103
16	011008020	HEX. HEAD BOLT	16	REPLACES 0017108020
18	011008020	HEX. HEAD BOLT	10	REPLACES 0017108020
19	3385155104	COVER	2	
20	011206020	HEX. HEAD BOLT	8	REPLACES 0017106020
21	3345125204	COVER, FRONT FRAME	1	
22	011008020	HEX. HEAD BOLT	6	REPLACES 0017108020
23	3345132113	CENTER FRAME	1	
24	3345132203	CENTER FRAME	1	
25	012210040	HEX. HEAD BOLT	8	REPLACES 0010014040
26	0041614000	PLAIN WASHER	16	
27	030214350	LOCK WASHER	8	REPLACES 0040014000
28	0030014000	HEX. NUT	8	
29	012012030	HEX. HEAD BOLT	10	REPLACES 0010012030
30	0040012000	LOCK WASHER	10	
31	031112230	PLAIN WASHER	10	REPLACES 0041612000
32	3345141202	REAR FRAME	1	UP TO S/N3311949
	3345141212	REAR FRAME	1	S/N3311950~
33	3345109303	LINING	1	
34	B3561100204	STRIPE	2	REPLACES 3340630704
35	011008020	HEX. HEAD BOLT	4	REPLACES 0017108020
36	3345155103	COVER, REAR FRAME	1	
37	3345109403	LINING	1	
38	031108160	PLAIN WASHER	8	REPLACES 0041608000
39	0040008000	LOCK WASHER	8	
40	011008040	HEX. HEAD BOLT	8	REPLACES 0010008040

DCA-40SSAI --- ENCLOSURE ASSY.

ENCLOSURE ASSY.

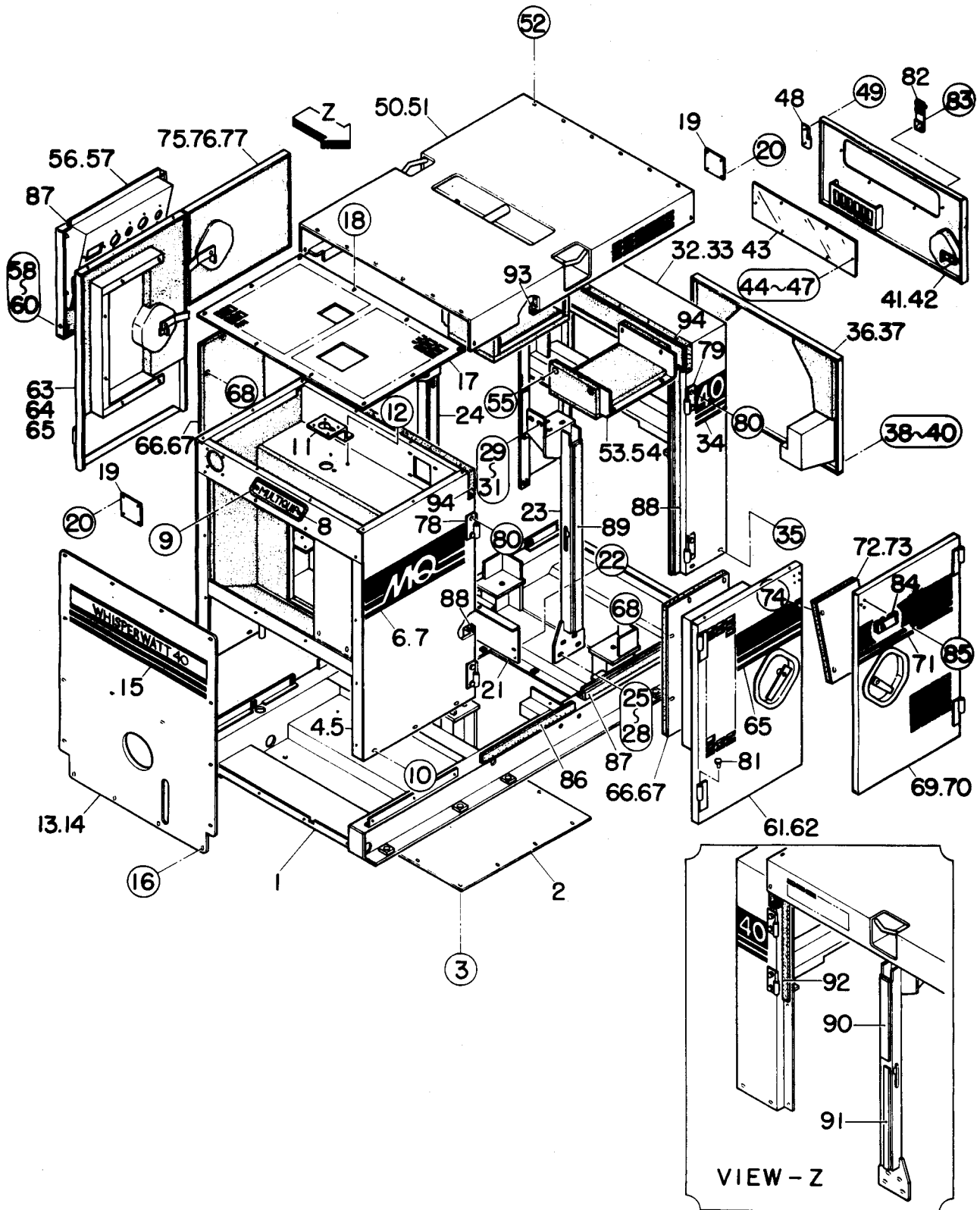

DCA-40SSAI --- ENCLOSURE ASSY.

ENCLOSURE ASSY.

<u>NO.</u>	<u>PART NO.</u>	<u>ITEM</u>	<u>QTY.</u>	<u>REMARKS</u>
41	3345143303	DOOR, REAR FRAME	1	UP TO S/N3311949
	3345143313	DOOR, REAR FRAME	1	S/N3311950~
42	1320332003	STICKER	1	
43	3805147104	WINDOW PLATE	1	REPLACES 33805147104
44	0021006020	MACHINE SCREW	6	
45	952404470	PLAIN WASHER	6	REPLACES 0041606000
46	0040006000	LOCK WASHER	6	
47	020106050	HEX. NUT	6	REPLACES 0030006000
48	0845028303	HINGE	2	
49	011208025	HEX. HEAD BOLT	4	REPLACES 0017108025
50	3345161212	ROOF PANEL	1	
51	3345109503	LINING	1	
52	011008020	HEX. HEAD BOLT	16	REPLACES 0017108020
53	3345165104	GUIDE PANEL, AIR	2	
54	3345109604	LINING	2	
55	011008020	HEX. HEAD BOLT	8	REPLACES 0017108020
56	3345181202	SPLASHER PANEL	1	
57	3345105304	LINING	1	
58	0010008055	HEX. HEAD BOLT	6	
59	0040008000	LOCK WASHER	6	
60	031108160	PLAIN WASHER	6	REPLACES 0041608000
61	3345124003	SIDE DOOR, LEFT SIDE	1	UP TO S/N3311949
	3345124013	SIDE DOOR, LEFT SIDE	1	S/N3311950~
62	3345109704	LINING	1	
63	3345124103	SIDE DOOR, RIGHT SIDE	1	UP TO S/N3311949
	3345124113	SIDE DOOR, RIGHT SIDE	1	S/N3311950~
64	3345109804	LINING	1	
65	3340630904	STRIPE	2	
66	3345175104	GUIDE PANEL, AIR	2	
67	3345105104	LINING	2	
68	011008020	HEX. HEAD BOLT	12	REPLACES 0017108020
69	3345171803	SIDE DOOR, LEFT SIDE	1	UP TO S/N3311949
	3345171813	SIDE DOOR, RIGHT SIDE	1	S/N3311950~
70	33451009904	LINING	1	
71	3340631104	STRIPE	1	
72	3345175004	GUIDE PANEL, AIR	1	
73	3345105204	LINING	1	
74	011008020	HEX. HEAD BOLT	4	REPLACES 0017108020
75	3345171903	SIDE DOOR, RIGHT SIDE	1	UP TO S/N3311949
76	3345105004	LINING	1	
77	B3561100403	STRIPE	1	REPLACES 3340631304
78	0845028203	HINGE	4	
79	0845028303	HINGE	4	
80	011208025	HEX. HEAD BOLT	16	REPLACES 0017108025
81	0845031504	CAP	10	

DCA-40SSAI --- ENCLOSURE ASSY.

ENCLOSURE ASSY.

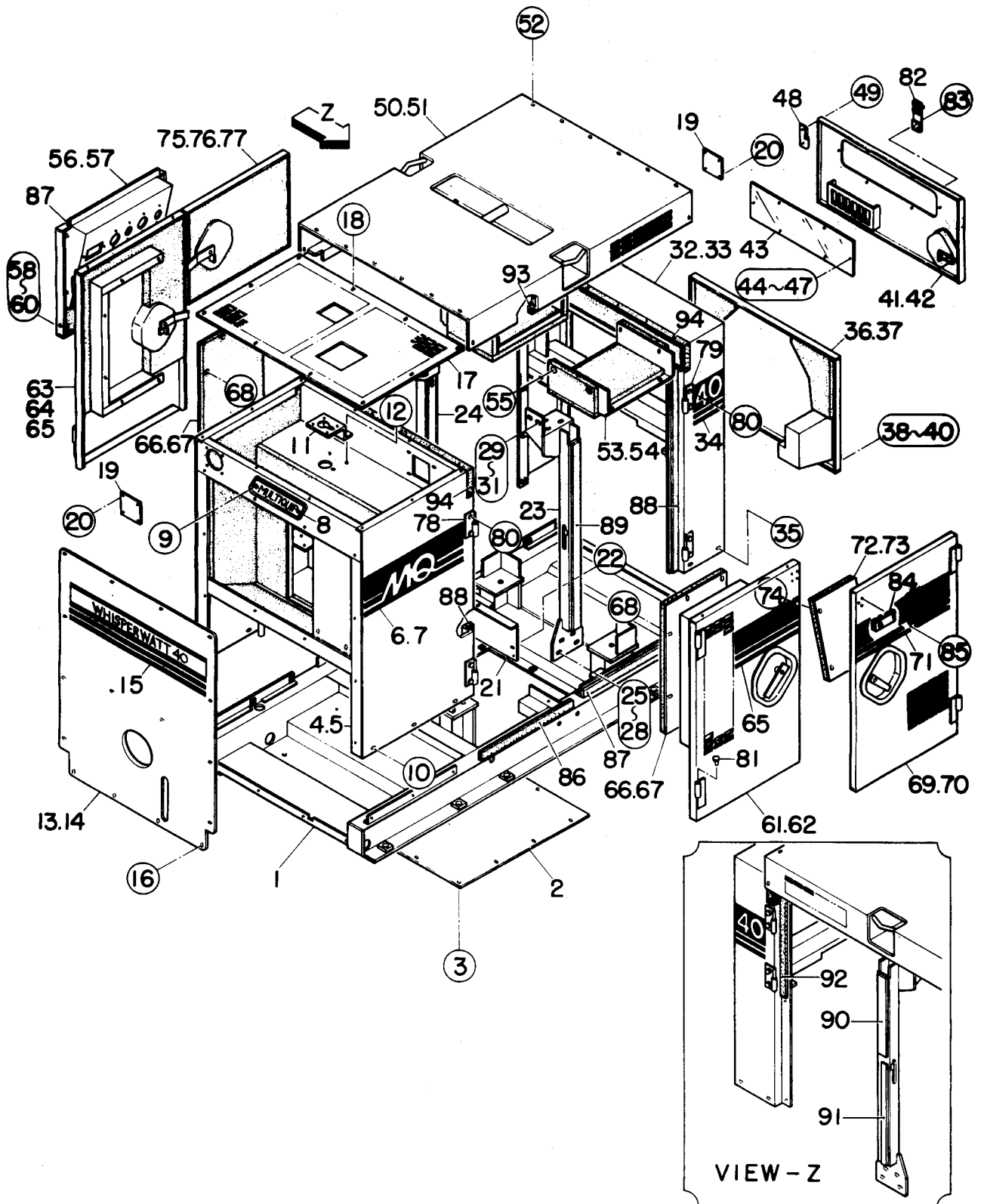

ENCLOSURE ASSY.

<u>NO.</u>	<u>PART NO.</u>	<u>ITEM</u>	<u>QTY.</u>	<u>REMARKS</u>
82	0605010910	LATCH	1	UP TO S/N3311949; REPLACES 0605010910
83	0027103010	MACHINE SCREW	7	UP TO S/N3311949
84	0605010910	LATCH	2	UP TO S/N3311949
85	0027104010	MACHINE SCREW	14	UP TO S/N3311949
86	3345104104	RUBBER SEAL	2	
87	3345104204	RUBBER SEAL	2	
88	3345104304	RUBBER SEAL	3	
89	3345104404	RUBBER SEAL	1	
90	3345104504	RUBBER SEAL	1	
91	3345104604	RUBBER SEAL	1	
92	3345104704	RUBBER SEAL	1	
93	3345104804	RUBBER SEAL	2	
94	3345104904	RUBBER SEAL	2	

DECAL ASSY.

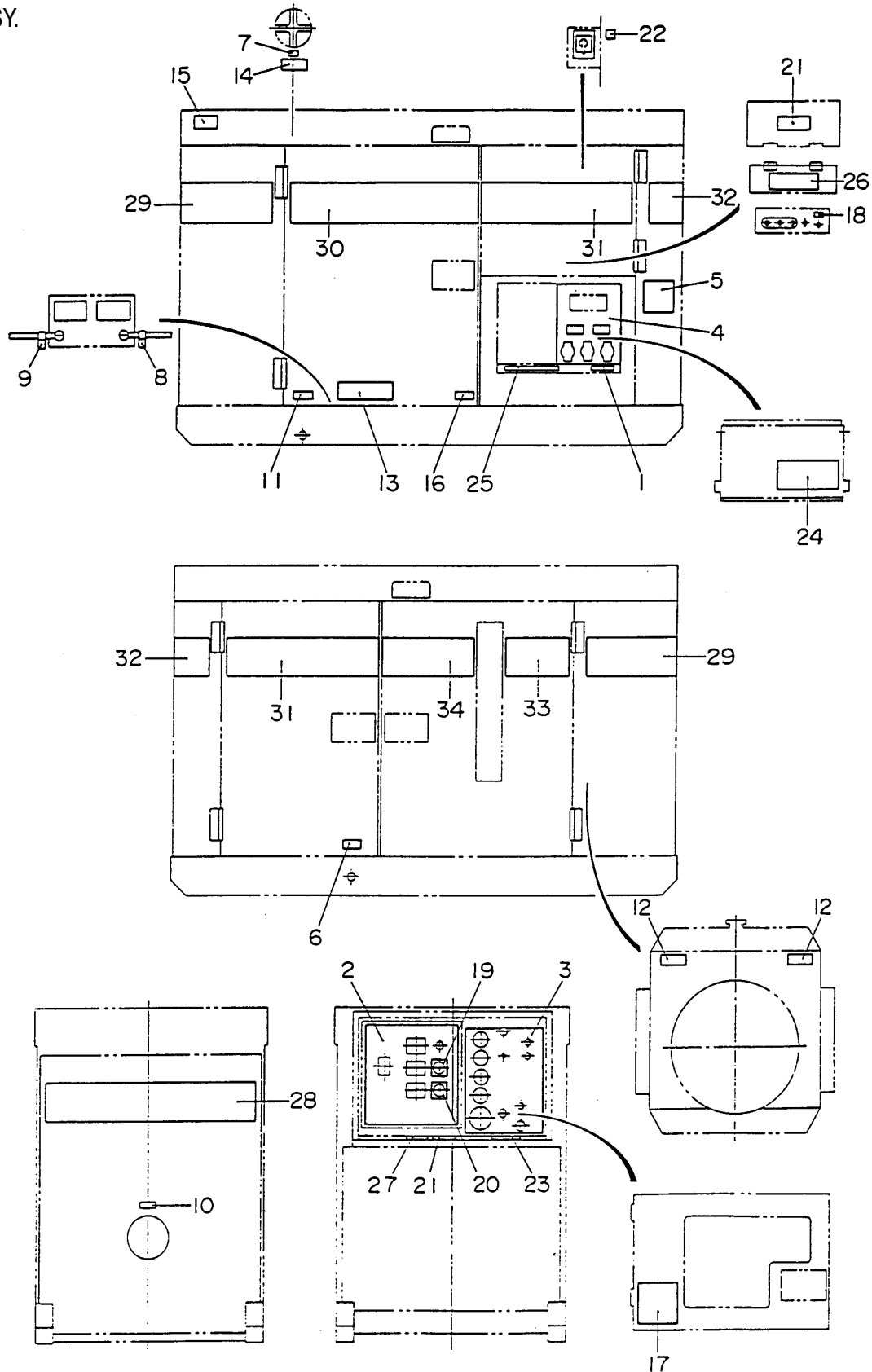

DECAL ASSY.

<u>NO.</u>	<u>PART NO.</u>	<u>ITEM</u>	<u>QTY.</u>	<u>REMARKS</u>
1	M1550000204	DECAL; NOTE	1	M15000020
2	M1550001003	DECAL; GENERATOR CONTROL	1	M15000100
3	M1550000603	DECAL; ENGINE OPERATING	1	M15000060
4	M1550000703	DECAL; AUXILIARY OUTPUT	1	M15000070
5	M1550000804	DECAL; NOTE	1	M15000080
6	M9500000004	DECAL; OIL DRAIN PLUG	1	M9000000
7	M9500100004	DECAL; WATER	1	M90010000
8	M9500300004	DECAL; -	1	M90030000
9	M9500300104	DECAL; +	1	M90030010
10	M9500500004	DECAL; DIESEL FUEL	1	M90050000
11	M9500500104	DECAL; FUEL DRAIN PLUG	1	M90050010
12	M9503000004	DECAL; WARNING	2	M90300000
13	M9503000103	DECAL; WATER, OIL CHECK	1	M90310000
14	M9503100004	DECAL; WARNING	1	M90320000
15	M9503200004	DECAL; WARNING	1	M90320000
16	M9510100004	DECAL; CAUTION	1	M91010000
17	M9510200002	DECAL; MQ	1	M91020000
18	M9520000004	DECAL; GROUND	1	M92000000
19	M9520000104	DECAL; AMMETER CHANGE-OVER SWITCH	1	M92000010
20	M9520000204	DECAL; VOLTMETER CHANGE-OVER SWITCH ..	1	M92000020
21	M9520100004	DECAL; WARNING	2	M92010000
22	M9520100204	DECAL; CAUTION	1	M92010020A
23	M9520100304	DECAL; SAFETY INSTRUCTIONS	1	M92010030
24	M9520100404	DECAL; DANGER	1	M92010040
25	M9520100503	DECAL; WARNING	1	M92010050
26	M9520200003	DECAL; CONNECTION OF OUTPUT CABLE	1	M92020000
27	M9520200104	DECAL; OVER CURRENT RELAY	1	M92020010

ISUZU 4BD1 — CYLINDER HEAD COVER ASSY.

CYLINDER HEAD COVER ASSY.

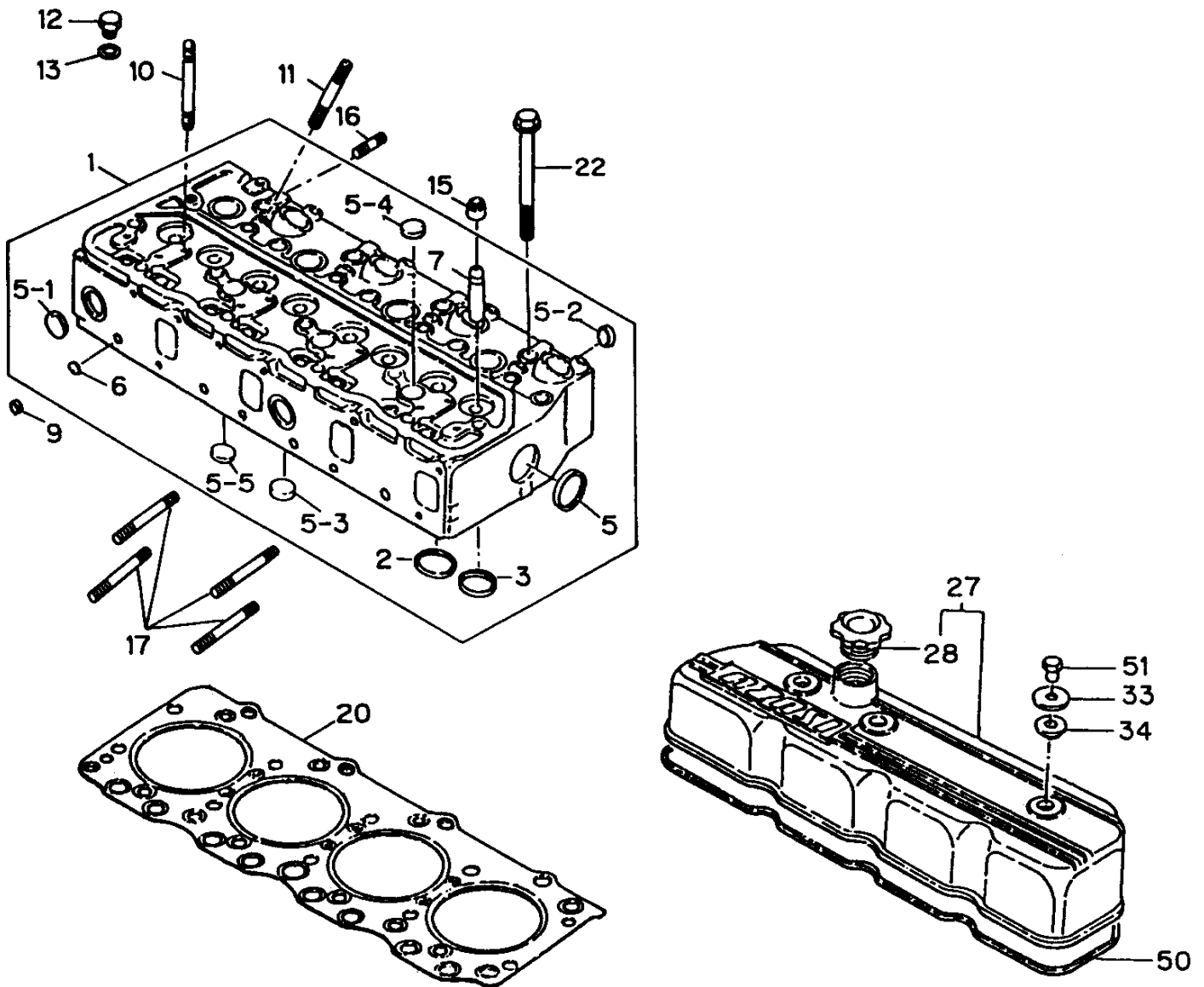

ISUZU 4BD1 — CYLINDER HEAD COVER ASSY.

CYLINDER HEAD COVER ASSY.

<u>NO</u>	<u>PART NO</u>	<u>PART NAME</u>	<u>QTY.</u>	<u>REMARKS</u>
1	5111101680	CYLINDER HEAD ASSY.	1	INCL. ITEMS W/#
2#	9117156070	VALVE SEAT, INTAKE	4	
3#	9117118030	VALVE SEAT, EXHAUST	4	
5#	1096000580	SEALING CUP, REAR FACE	1	REPLACES 1096000051
5-1#	1096000121	SEALING CUP, EXHAUST MAN.	2	REPLACES 5112190150
5-2#	1096000160	SEALING CUP, INLET SIDE FACE	4	
5-3#	9111291280	SEALING CUP, LOWER FACE	2	
5-4#	1096000160	SEALING CUP, TOP FAC	3	
5-5#	50960000130	SEALING CUP, DRILLED PASS	4	
6#	909600340	PLUG	4	
7#	5117210010	VALVE GUIDE	8	
9	9111296010	SEAL CUP	4	
10	5093000650	ROCKER ARM STUD	3	
11	1093000180	INJ. NOZZLE STUD	8	
12	9092023100	PLUG, TOP FACE	1	
13	9095714100	PACKING, COMMET	1	
15	1125690150	VALVE GUIDE SEAL	8	
16	9041108200	STUD, INL. MANIFOLD	2	REPLACES 9041108250
17	9098301770	STUD, EXH. MANIFOLD	3	
20	8941458390	GASKET, CYL. HEAD	1	
22	8943674370	BOLT	18	REPLACES 8943674380
27	5111702672	CYL. HEAD COVER ASSY.	1	INCL. ITEMS W/&
28&	1117510051	CAP, OIL FILLER	1	REPLACES 9117510381
33	9111791050	WASHER		
34	1096390320	PACKING, HEAD COVER	3	REPLACES 9111790300
50	5111730160	PACKING, CYL. HEAD	1	
51	9111750120	NUT	1	

ISUZU 4BD1 — CYLINDER BLOCK ASSY.

CYLINDER BLOCK ASSY.

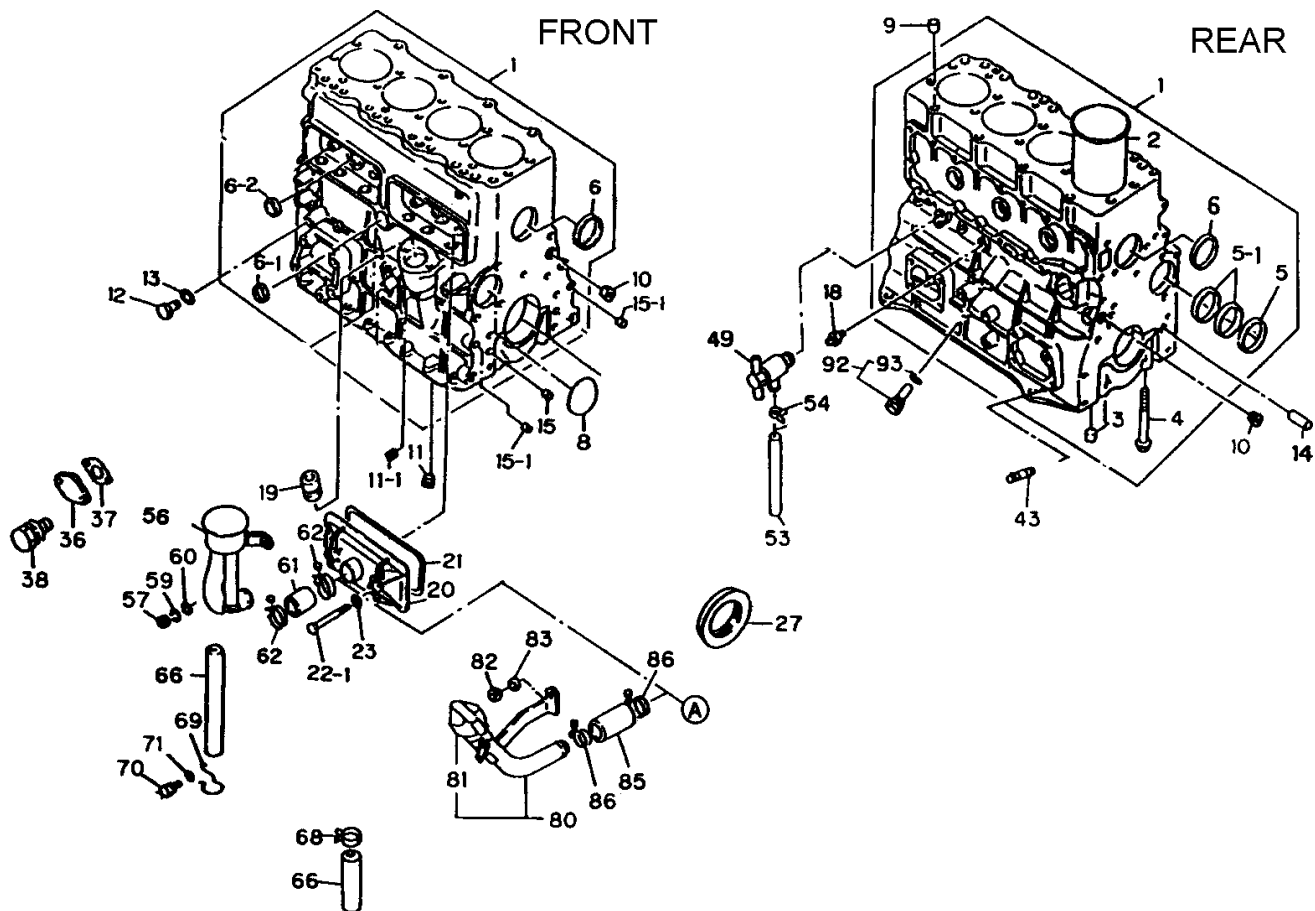

ISUZU 4BD1 — CYLINDER BLOCK ASSY.

CYLINDER BLOCK ASSY.

<u>NO</u>	<u>PART NO</u>	<u>PART NAME</u>	<u>QTY.</u>	<u>REMARKS</u>
1	8941303284	CYL. BLOCK ASSY	1	INCL. ITEMS W/#
2#	5878131240	LINING	4	REPLACES 1112611180
3#	5112570011	DOWEL	1	
4#	1090004691	BOLT	10	
5#	9116910480	CAM., FRONT METAL	1	REPLACES 9116110480
5-1#	9116930350	CAM., REAR AND CENTER	2	REPLACES 9116130350
6#	1096000520	CEALING CUP, FRONT AND REAR	2	
6-1#	5112190140	SEALING CUP, CYL. BLOCK	1	
6-2#	1096000121	SEALING CUP, TAPPET D=32	2	
8	9098600190	PLUG, CAMSHAFT PLATE	1	
9	8941480790	DOWEL	2	
10	1096050681	PLUG, HEADLESS PT 1/2	2	
11	5096050050	OIL PLUG, GALLERY	1	REPLACES 9992055170
11-1	5096050180	PLUG	7	
12	9992023140	OIL PLUG, GALLERY	1	
13	9095720140	PACKING	1	
14	1097400780	STRAIGHT PIN, GEAR CASE	1	
15-1	9081510180	STRAIGHT PIN, FLYWHEEL HSG.	2	
18	8941075600	INJ. PUMP NIPPLE	1	
19	5112240040	BUSHING, OIL PUMP DRIVE SHAFT1	1	
20	5112901450	COVER, TAPPET CHAMBER	1	
21	8943673680	PACKING, CYL. BLOCK COVER	2	
22	8941075662	BOLT	2	
22-1	8944299951	BOLT	2	
23	9095720080	PACKING, GROMMET	4	
27	1096253620	SEAL, REAR OIL CRANK	1	
30	5111290030	SEALING CUP, LEVEL GAUGE	1	
36	8941745290	COVER, OIL DRAIN	1	
37	8943210180	PACKING, COVER	1	
38	0500408180	BOLT	2	
43	1093000530	STUD, ENGINE FOOT	1	
49	5096800110	WATER DRAIN COCK	1	
53	9099135050	PIPE	1	
54	5097070041	DRAIN PIPE CLIP	1	
56	5117401200	AIR BREATHER ASSY.	1	
57	1094400401	NUT	2	REPLACES 9091104080
59	1099851770	LOCK WASHER	2	REPLACES 9091505080
60	9091645080	PLAIN WASHER	2	
61	8944338700	BREATHER HOSE	1	
62	8941625680	CLIP	2	REPLACES 1097071340
66	5093608820	VINYL PIPE	1	REPLACES 9097130740
69	5097040331	CLIP	1	

ISUZU 4BD1 — CYLINDER BLOCK ASSY.

CYLINDER BLOCK ASSY.

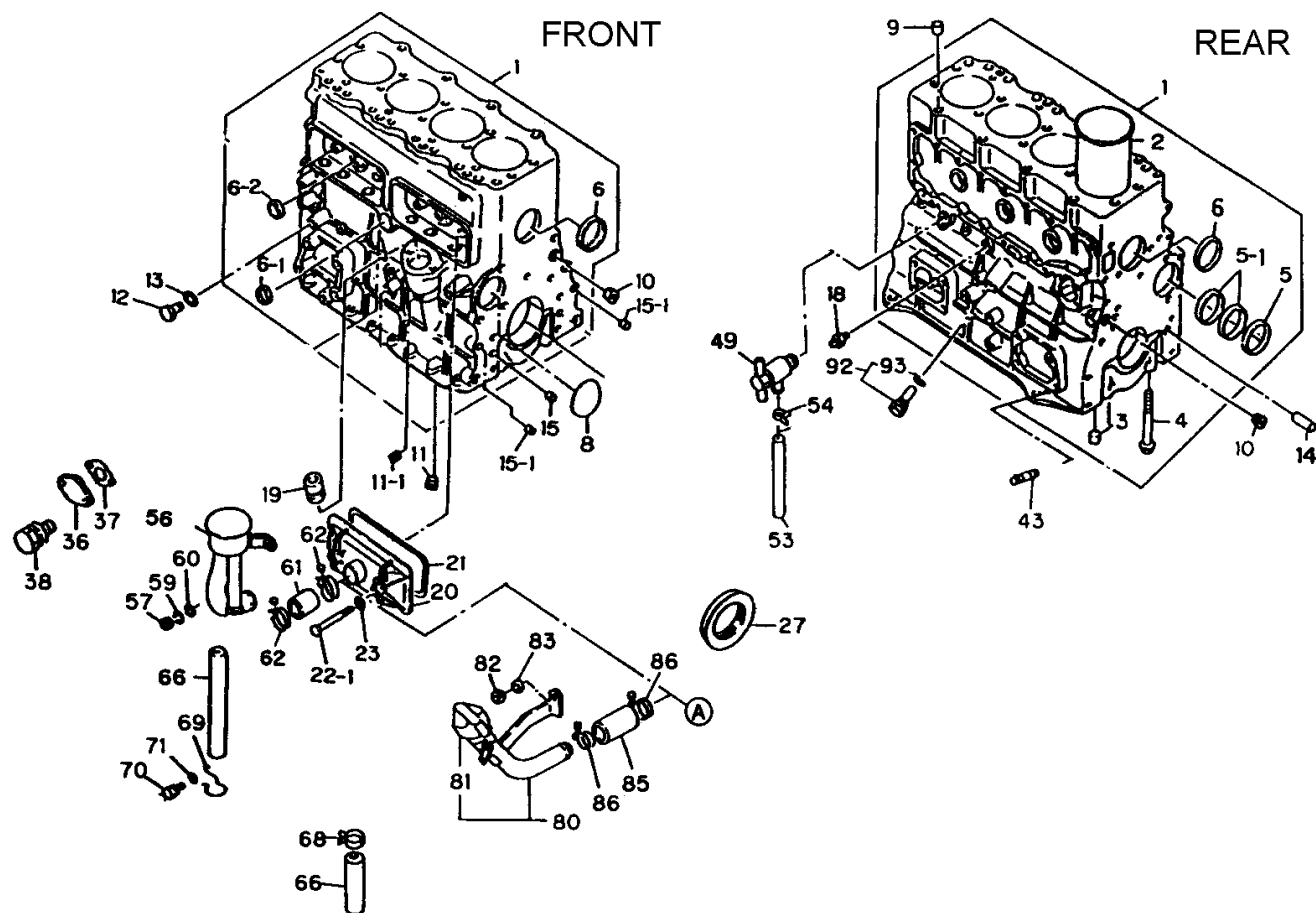

ISUZU 4BD1 — CYLINDER BLOCK ASSY.

CYLINDER BLOCK ASSY.

<u>NO</u>	<u>PART NO</u>	<u>PART NAME</u>	<u>QTY.</u>	<u>REMARKS</u>
70	0500408160	BOLT	1	
71	9091606080	PLAIN WASHER	1	
80	8941405811	OIL FILLER ASSY.	1	
81	1117500120	OIL FILLER CAP	1	
82	1094400401	NUT	1	REPLACES 9091104080
83	1099851770	LOCK WASHER.....	1	REPLACES 9091505080
85	9099129760	HOSE	1	
86	9099155531	CLIP	2	
92	8970233390	VALVE RELIEF ASSY.	1	INCL. ITEM W/@
93@	5096230350	PACKING	1	

ISUZU 4BD1 —TIMING GEAR ASSY.

TIMING GEAR ASSY.

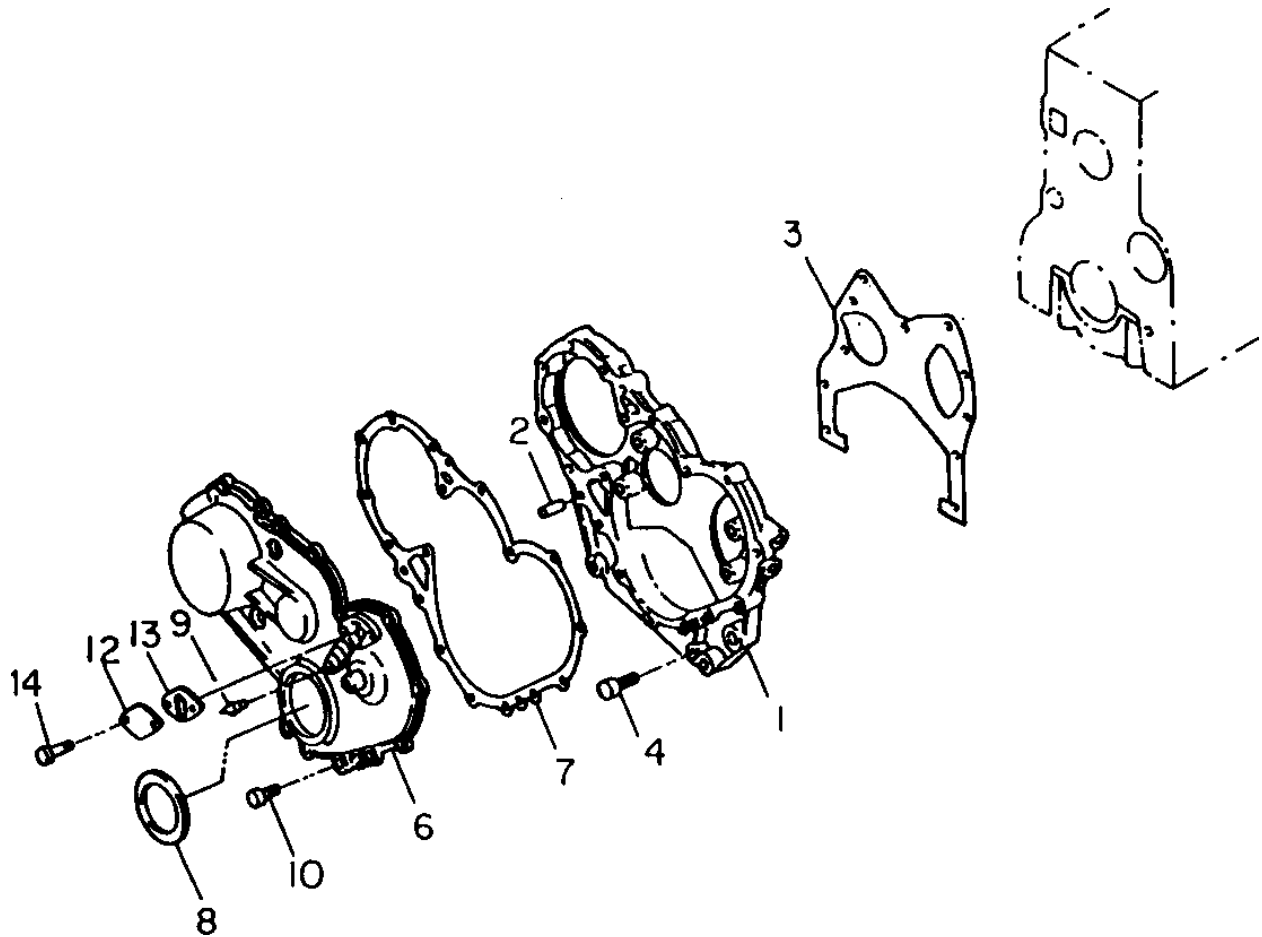

ISUZU 4BD1 —TIMING GEAR ASSY.

TIMING GEAR ASSY.

<u>NO.</u>	<u>PART NO.</u>	<u>PART NAME</u>	<u>QTY.</u>	<u>REMARKS</u>
1	5113110113	CASE	1	
2	9081510180	STRAIGHT PIN	1	
3	8943706710	PACKING	1	REPLACES 1113120140
4	0500408450	BOLT	6	REPLACES 0500408200
6	1113210790	COVER	1	
7	8943632690	PACKING	1	
8	1096254380	SEAL	1	REPLACES 1096253190
9	9113276020	POINTER	1	
10	0500408250	BOLT	7	
10	8941500451	BOLT	5	REPLACES 5090000841
12	5113210090	COVER, GEAR CHECK	2	
13	8971186980	GASKET	2	REPLACES 1112820130
14	0500406140	BOLT	4	

ISUZU 4BD1 — FLYWHEEL HOUSING ASSY.

FLYWHEEL HOUSING ASSY.

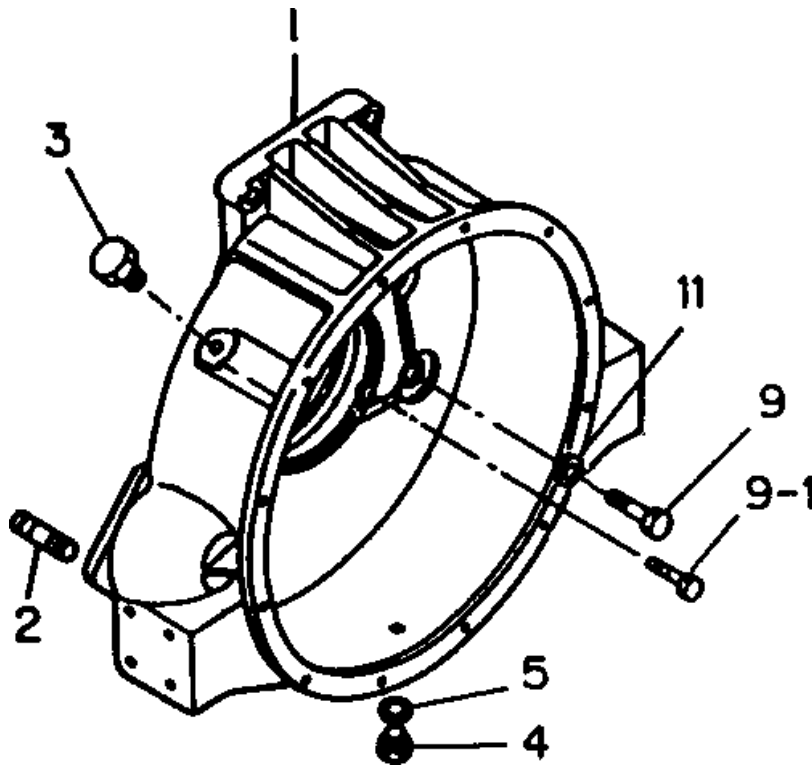

ISUZU 4BD1 — FLYWHEEL HOUSING ASSY.

FLYWHEEL HOUSING ASSY.

<u>NO.</u>	<u>PART NO.</u>	<u>PART NAME</u>	<u>QTY.</u>	<u>REMARKS</u>
1	8943213303	HOUSING	1	
3	8943218380	PLUG, PICK UP HOSE	1	
4	5096000090	DRAIN PLUG	1	REPLACES 9992023160
5	9095714160	PACKING	1	
9	9910664500	BOLT	8	
9-1	0500408250	BOLT	7	
11	9096510690	PLAIN WASHER	8	

ISUZU 4BD1 — OIL PAN ASSY.

OIL PAN ASSY.

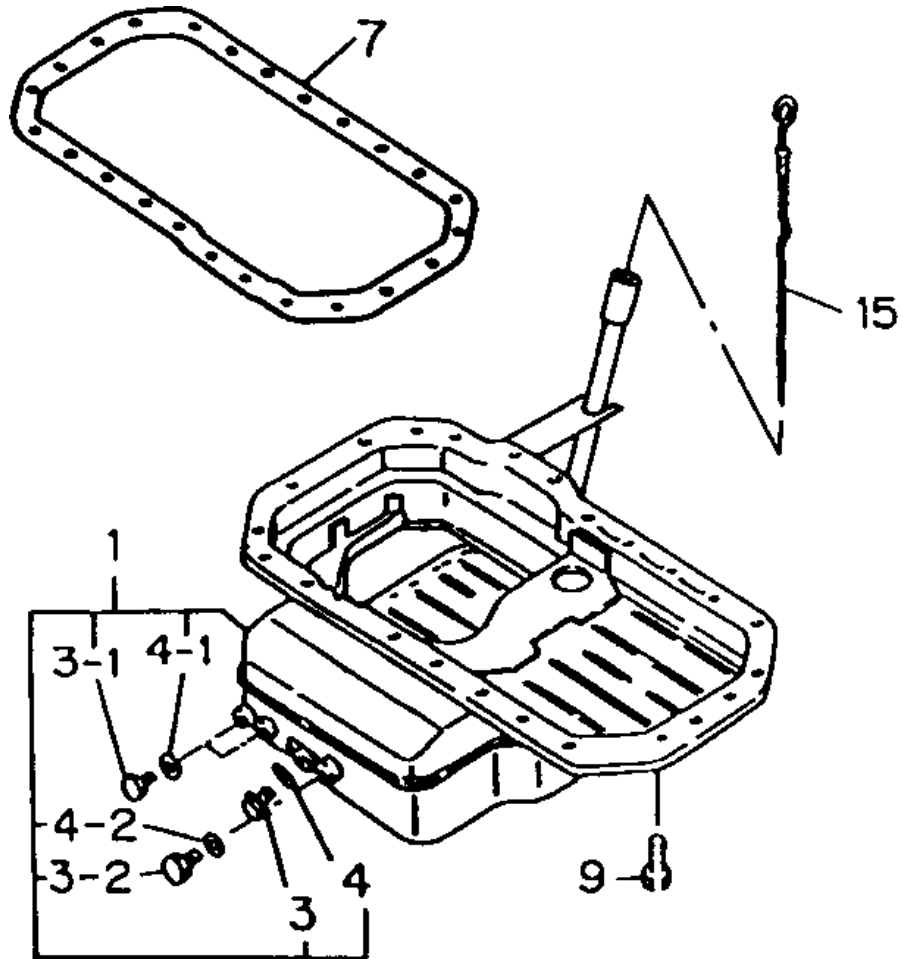

ISUZU 4BD1 — OIL PAN ASSY.

OIL PAN ASSY.

<u>NO</u>	<u>PART NO</u>	<u>PART NAME</u>	<u>QTY.</u>	<u>REMARKS</u>
1	8941340361	OIL PAN	1	INCL. ITEMS W/#
3#	9096620120	PLUG	1	
3-1#	5096000090	PLUG, THERMO SWITCH	2	REPLACES 9992023160
3-2#	1096040230	HEATER PLUG	1	REPLACES 9992023240
4#	1096231830	O RING	1	REPLACES 1096230570
4-1#	9095714160	PACKING	2	
4-2#	9095714240	PACKING	1	
7	8943708360	OIL PAN PACKING	1	UP TO MAR. 94
	8943706660	OIL PAN PACKING	1	APR. 94~
9	0500408180	BOLT	24	
15	5117601501	GAUGE ASSY.....	1	REPLACES 5117601500

ISUZU 4BD1 — OIL PUMP ASSY.

OIL PUMP ASSY.

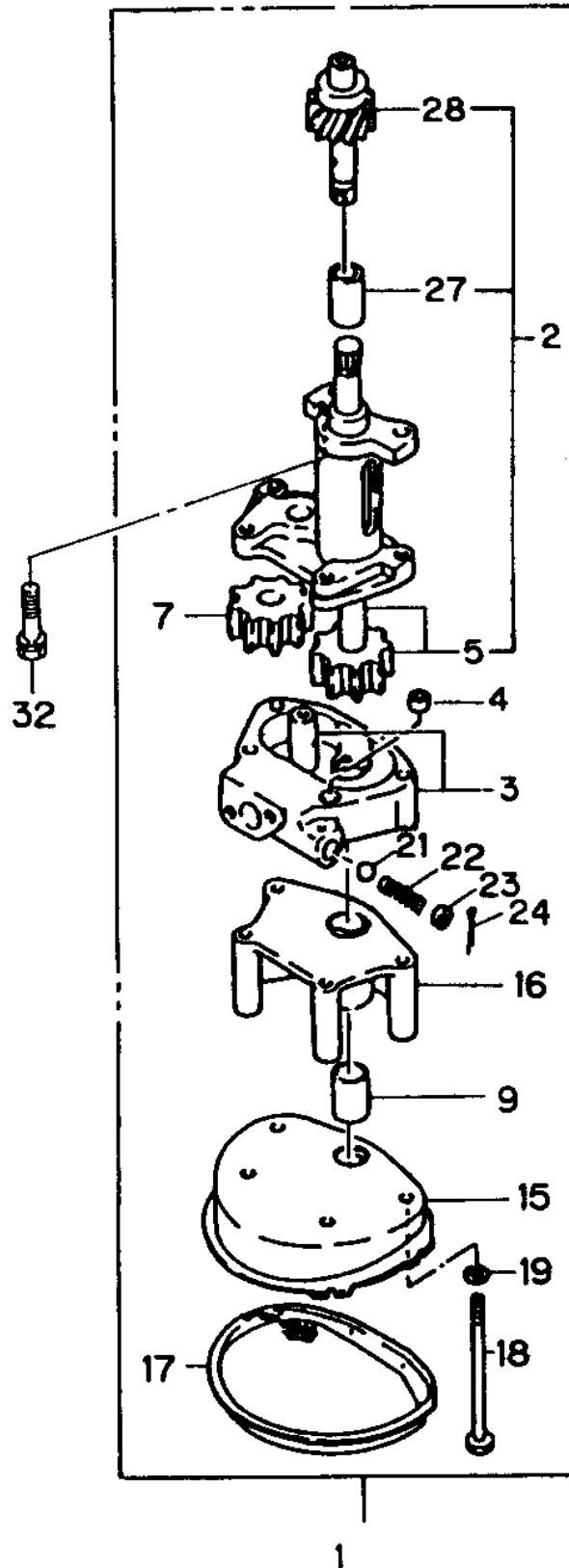

ISUZU 4BD1 — OIL PUMP ASSY.

OIL PUMP ASSY.

<u>NO.</u>	<u>PART NO.</u>	<u>PART NAME</u>	<u>QTY.</u>	<u>REMARKS</u>
1	5131001373	OIL PUMP ASSY.	1	INCL. ITEMS W/#
2#	5878102022	GEAR SET	1	INCL. ITEMS W/&
3#	5131130351	COVER ASSY.	1	
4#		DOWEL	1	CANNOT ORDER SEPARATELY
5#&	5131210140	SHAFT ASSY.	1	
7#	5131250020	GEAR	1	
9#	5131190060	PIPE	1	
15#	5131410171	CASE	1	
16#	1131190010	SPACER	1	
17#	0108058000	BOLT	4	REPLACES 9010458000
19#	1099851770	LOCKWASHER	4	REPLACES 9091505080
21#	5098430030	OIL RELIEF BALL	1	
22#	5095800980	COIL SPRING	1	
23#	5131650040	RELIEF VALVE SEAT	1	
24#	9081040300	PIN	1	
27#&	1131230160	COUPING	1	
28#&	1131280180	PINION	1	
32	0500410250	BOLT	2	

ISUZU 4BD1 — CRANKSHAFT, PISTON, FLYWHEEL ASSY.

CRANKSHAFT, PISTON, FLYWHEEL ASSY

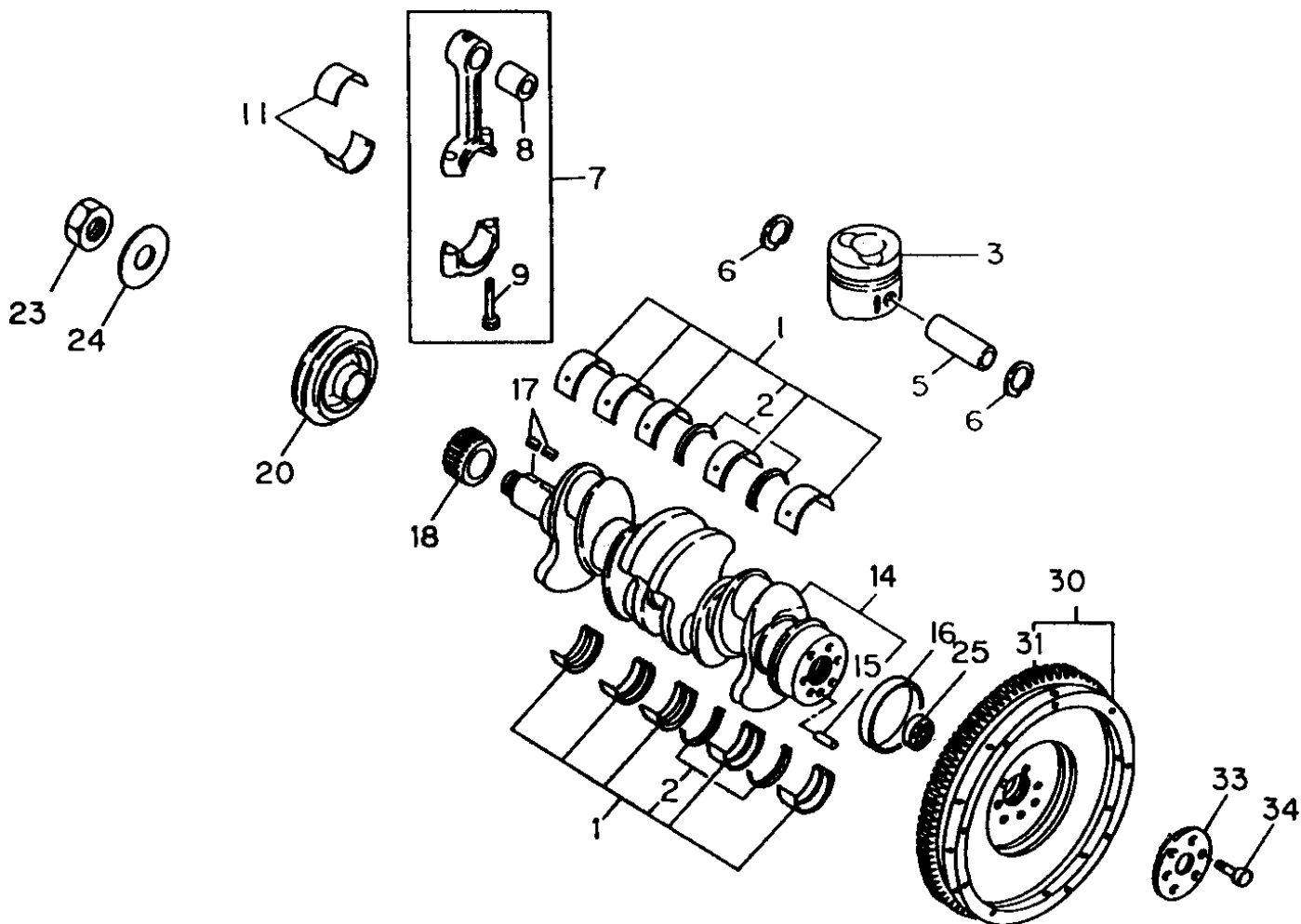

ISUZU 4BD1 — CRANKSHAFT, PISTON, FLYWHEEL ASSY.

CRANKSHAFT, PISTON, FLYWHEEL ASSY.

<u>NO.</u>	<u>PART NO.</u>	<u>PART NAME</u>	<u>QTY.</u>	<u>REMARKS</u>
1	8941170322	CRANKSHAFT ASSY.	1	INCL. ITEMS W/#
1-1	8941474660	METAL KIT, 0.25	1	
1-2	8941474670	METAL KIT, 0.50	1	
1-3	8941474680	METAL KIT, 0.75	1	
1-4	8941474690	METAL KIT, 1.00	1	
2#	8941145652	METAL SET, THRUST	2	
3	8971766340	PISTON SET	4	REPLACES 5121112111
4	5121210050	RING SET, PISTON	4	
5	9122116040	PISTON PIN	4	
6	8941075751	SNAP RING	8	REPLACES 8941075750
7	1122301041	CONNECTION ROD ASSY.	4	INCL. ITEMS W/&
8&	1122510270	BUSHING, SMALL END	4	
9&	1122350271	BOLT	8	
11	8970110310	METAL SET, STD	4	REPLACES 9122716080
11-1	9122736080	METAL SET, 0.25	4	
11-2	9122746080	METAL SET, 0.50	4	
11-3	9122756080	METAL SET, 0.75	4	
11-4	9122766080	METAL SET, 1.00	4	
14	5123101631	CRANKSHAFT ASSY.	1	INCL. ITEMS W/\$
15\$	9081612200	FLYWHEEL PIN	1	
17	8941075970	FEATHER KEY	2	
18	8971379100	CRANKSHAFT GEAR	1	REPLACES 9125210430
20	8944493661	PULLEY	1	REPLACES 8944493660
23	5123780020	NUT	1	
24	5095030240	WASHER	1	
25	1098002140	BALL BEARING	1	REPLACES 9000901570
30	8970461810	FLYWHEEL ASSY.	1	INCL. ITEMS W/%
31%	9123336070	RING GEAR	1	
33	5123360030	WASHER	1	
34	5123340060	BOLT	6	

ISUZU 4BD1 — CAMSHAFT, IDLE GEAR, ROCKER ASSY.

CAMSHAFT, IDLE GEAR, ROCKER ASSY.

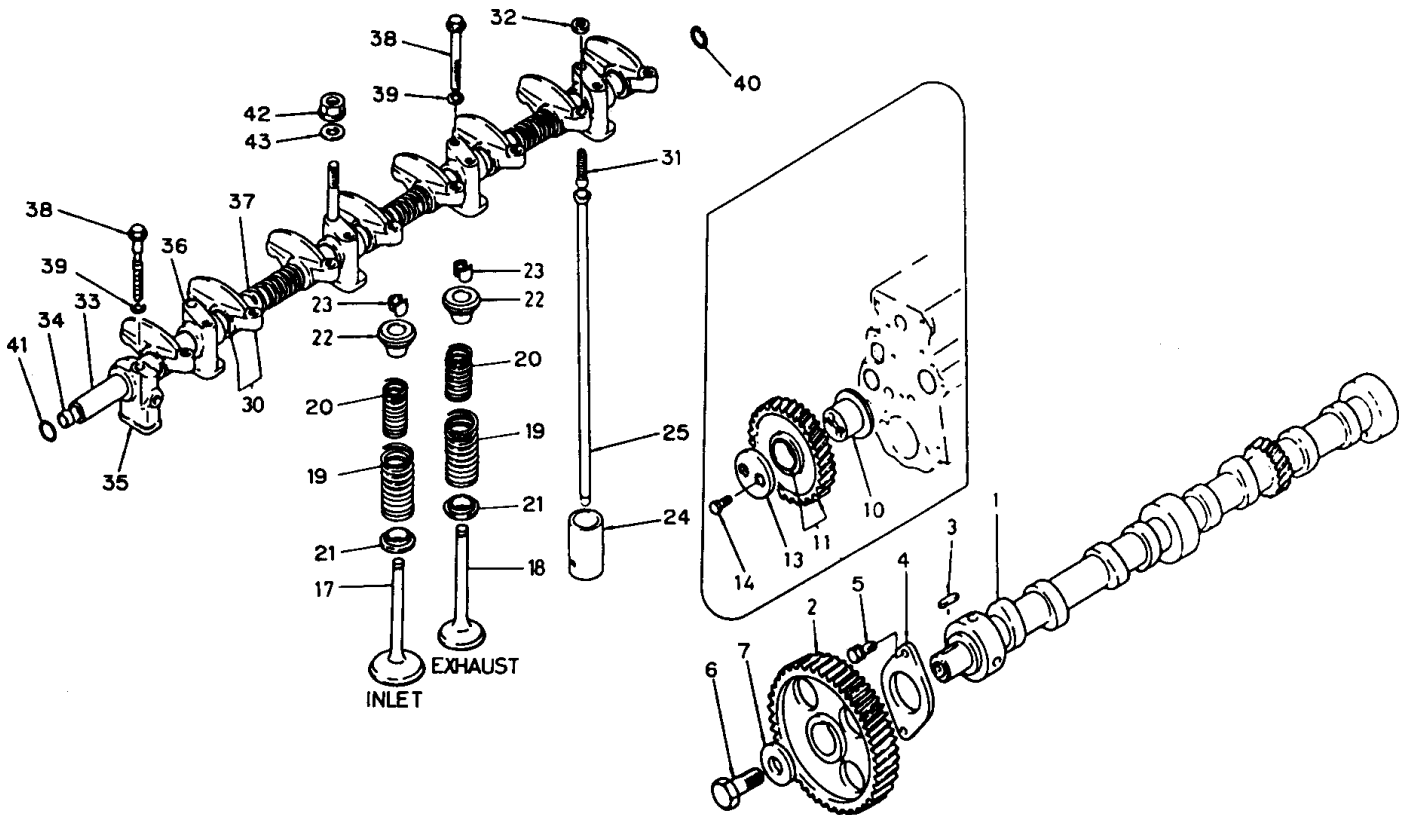

ISUZU 4BD1 — CAMSHAFT, IDLE GEAR, ROCKER ASSY.

CAMSHAFT, IDLE GEAR, ROCKER ASSY.

<u>NO.</u>	<u>PART NO.</u>	<u>PART NAME</u>	<u>QTY.</u>	<u>REMARKS</u>
1	8944094120	CAMSHAFT	1	
2	1125220162	GEAR	1	REPLACES 9125221471
3	9080107200	FEATHER KEY	1	
4	9116810150	THRUST PLATE	1	
5	0500408250	BOLT	2	
6	5090002360	BOLT	1	
7	9098518503	WASHER	1	
10	9125310300	IDLE GEAR SHAFT	1	
11	9125238014	IDLE GEAR	1	
13	5125350011	THRUST COLLAR	1	
14	5090300381	BOLT	2	
17	1125510501	INLET VALVE	4	
18	1125520251	EXHAUST VALVE	4	
19	5125610090	VALVE SPRING	8	
21	1125630351	SPRING SEAT, LOWER	8	
22	8941145760	SPRING SEAT, VALVE	8	
23	5125650060	SPLIT COLLAR	16	
24	5125710032	TAPPET	8	
25	1125750360	PUSH ROD	8	
30	5126110310	ROCKER ARM ASSY.	8	
31	9126160420	ADJUSTING SCREW	8	
32	9091115080	NUT	8	
33	8941295510	ROCKER ARM SHAFT	1	
34	9126260050	ROCKER ARM PLUG	2	
35	5126280120	BRACKET, FRONT	1	
36	9126281050	BRACKET, INNER	4	
37	1095803350	SPRING	3	
38	1090005670	BOLT	6	
39	9098514300	WASHER	6	
40	9091800190	SNAP RING	1	
41	5096230600	O RING PACKING	1	
42	1094001160	NUT	3	
43	9098514300	PLAIN WASHER	3	

ISUZU 4BD1 — OIL AND FUEL FILTER ASSY.

OIL AND FUEL FILTER ASSY.

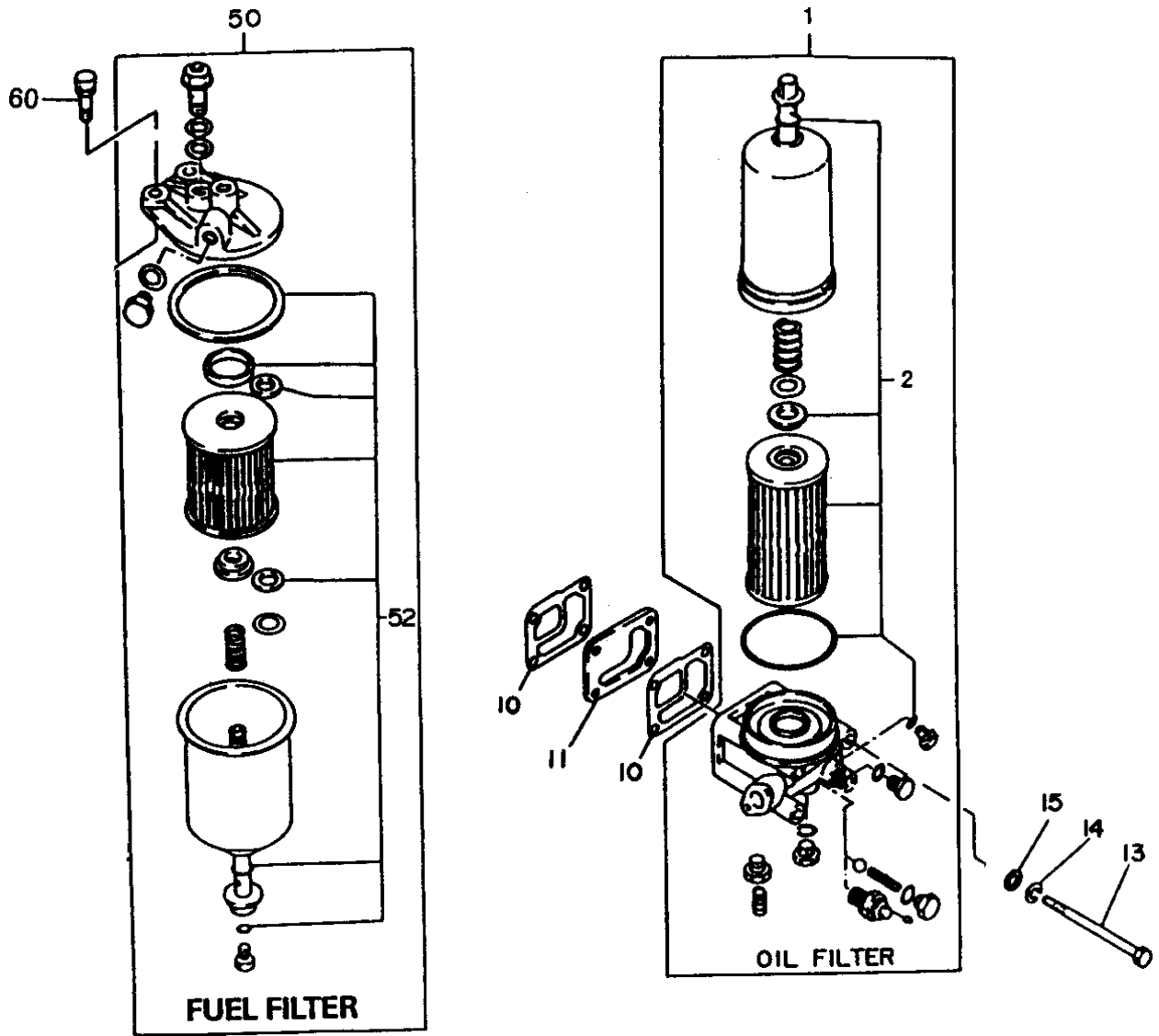

ISUZU 4BD1 — OIL AND FUEL FILTER ASSY.

OIL AND FUEL FILTER ASSY.

<u>NO.</u>	<u>PART NO.</u>	<u>PART NAME</u>	<u>QTY.</u>	<u>REMARKS</u>
1	5132002262	OIL FILTER ASSY.	1	INCL. ITEMS W/; REPLACES 5132002262
2#	1878102201	OIL FILTER ELEMENT KIT	1	
10	8943706700	PACKING	2	UP TO MAR. 94; REPLACES 1132191940
	8943706700	PACKING	2	APR. 94~
11	5132190261	SPACER	1	
13	5090000071	BOLT	4	
14	030210250	LOCK WASHER	4	REPLACES 9091505100
15	9091645100	PLAIN WASHER	4	REPLACES 9091605100
50#	9132004193	FUEL FILTER ASSY.	1	INCL. ITEMS W/
52#&	5878100500	FUEL FILTER ELEMENT KIT	1	
60	0501510350	BOLT	2	

ISUZU 4BD1 — OIL PIPING ASSY.

OIL PIPING ASSY.

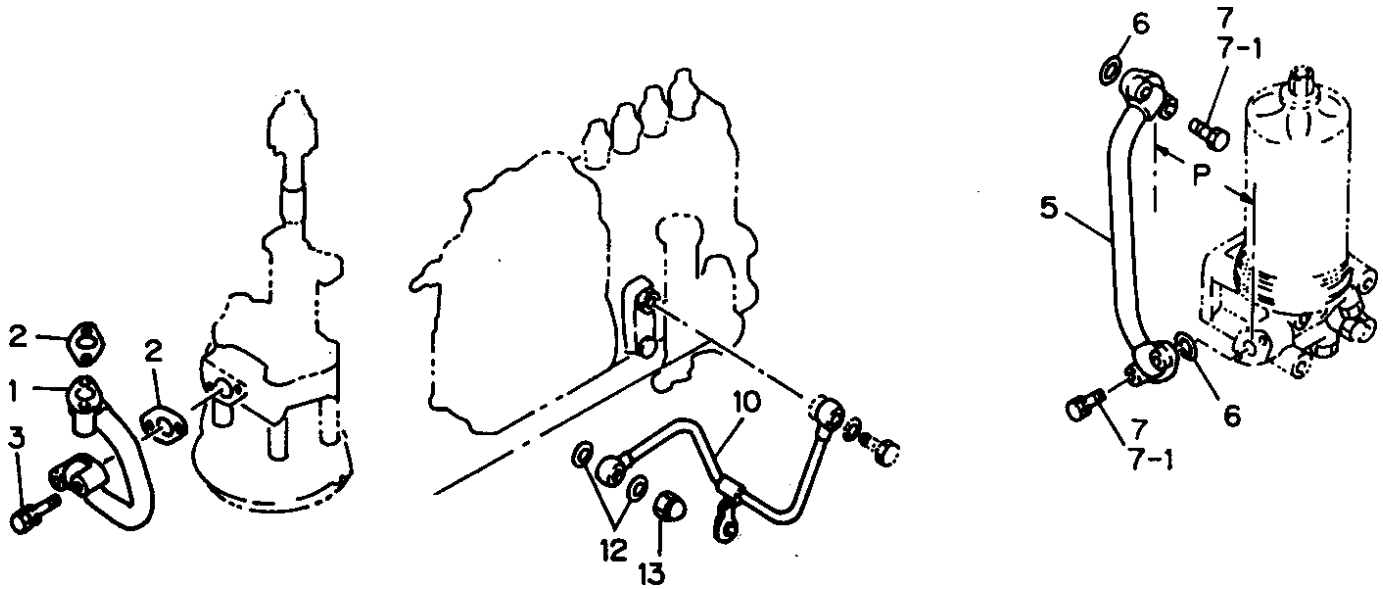

ISUZU 4BD1 — OIL PIPING ASSY.

OIL PIPING ASSY.

<u>NO.</u>	<u>PART NO.</u>	<u>PART NAME</u>	<u>QTY.</u>	<u>REMARKS</u>
1	8941753012	OIL PUMP ASSY.	1	
2	9099211880	PACKING	2	
3	0501408450	BOLT	4	
5	5133112561	FILTER PIPE ASSY.	1	
6	1096234620	PACKING	2	
7	0500408350	BOLT	2	
7-1	0500408320	BOLT	2	
10	8944284630	OIL INJECTION PIPE ASSY.	1	
12	9095720100	PACKING	2	
13	909840220	NUT	1	

ISUZU 4BD1 — COOLING ASSY.

COOLING ASSY.

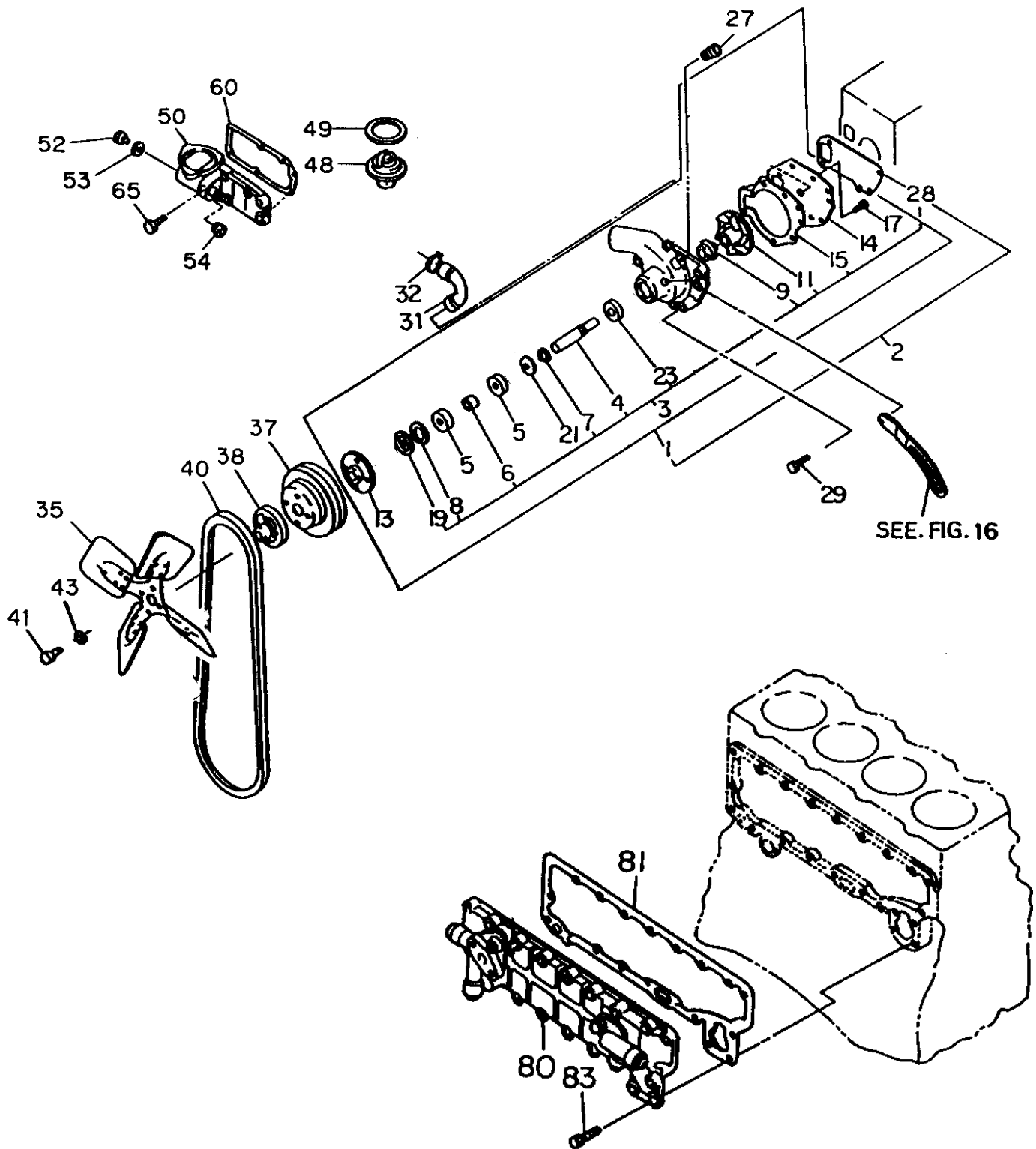

ISUZU 4BD1 — COOLING ASSY.

COOLING ASSY.

<u>NO.</u>	<u>PART NO.</u>	<u>PART NAME</u>	<u>QTY.</u>	<u>REMARKS</u>
1	5136101582	WATER PUMP ASSY.	1	INCL. ITEMS W/#
2#	8943763780	WATER PUMP KIT	1	INCL. ITEMS W/%
3&	5878101145	WATER PUMP REPAIR KIT	1	INCL. ITEMS W/&
4&	5136310100	SHAFT	1	
5&	1098002620	BALL BEARING	2	REPLACES 5098000520
6&	5136320010	SPACER	1	
7&	9099521030	SNAP RING	1	
8&	9091801470	SNAP RING	1	
9%&	1136200200	SEAL UNIT ASSY.	1	REPLACES 8942366870
11%&	5136210110	IMPELLER	1	
13&	5136420530	FAN	1	
14%	5136120100	WATER PUMP COVER	1	
15%&	8944728780	PACKING	1	REPLACES 5136130070
17%&	9030906200	SCREW	3	REPLACES 9030908200
19&	5136390020	DUST COVER	1	
21&	5136340030	SPACER	1	
23%&	5096250780	SEAL	1	REPLACES 5096250570
27	5096050050	PLUG	1	
28%&	8943706610	PACKING	1	REPLACES 9136140440
29	0500410400	BOLT	1	
	0500410500	BOLT	2	
	5090300101	BOLT, WATER PUMP	2	
31	5093610700	HOSE, BY-PASS	1	
32	5097040313	CLIP, D=38	1	
	1097040940	CLIP, D=36	1	
35	9136600930	FAN ASSY.	1	
37	5136630311	PULLEY	1	
38	5136420581	SPACKER	1	
40	5136710450	BELT	1	
41	0500405600	BOLT	4	
43	8943127330	LOCK WASHER	4	REPLACES 9098516490
48	9137700941	THERMOSTAT	1	REPLACES 5137700320
49	8941760310	PACKING	1	
50	5137160451	THERMOSTAT HOUSING	1	
52	9096610050	THERMO PLUG	1	
53	5096050050	PACKING	1	UP TO DEC. 93
	9095713160	PACKING	1	DEC. 93~
60	8943706740	PACKING	1	REPLACES 8943210100
62	5137130351	WATER PIPE	1	
63	0500408250	BOLT	3	
65	0501410250	BOLT	1	
	0500410400	BOLT	2	
	0501410350	BOLT	4	
80	5112800111	WATER DUCT COVER ASSY.	1	
81	8970196530	OIL COOLER PACKING	1	REPLACES 8943210130
83	0500408200	BOLT	2	
	0500408250	BOLT	11	
	0500408450	BOLT	8	
	8942059861	BOLT	1	

ISUZU 4BD1 — INTAKE AND EXHAUST ASSY.

INTAKE AND EXHAUST ASSY.

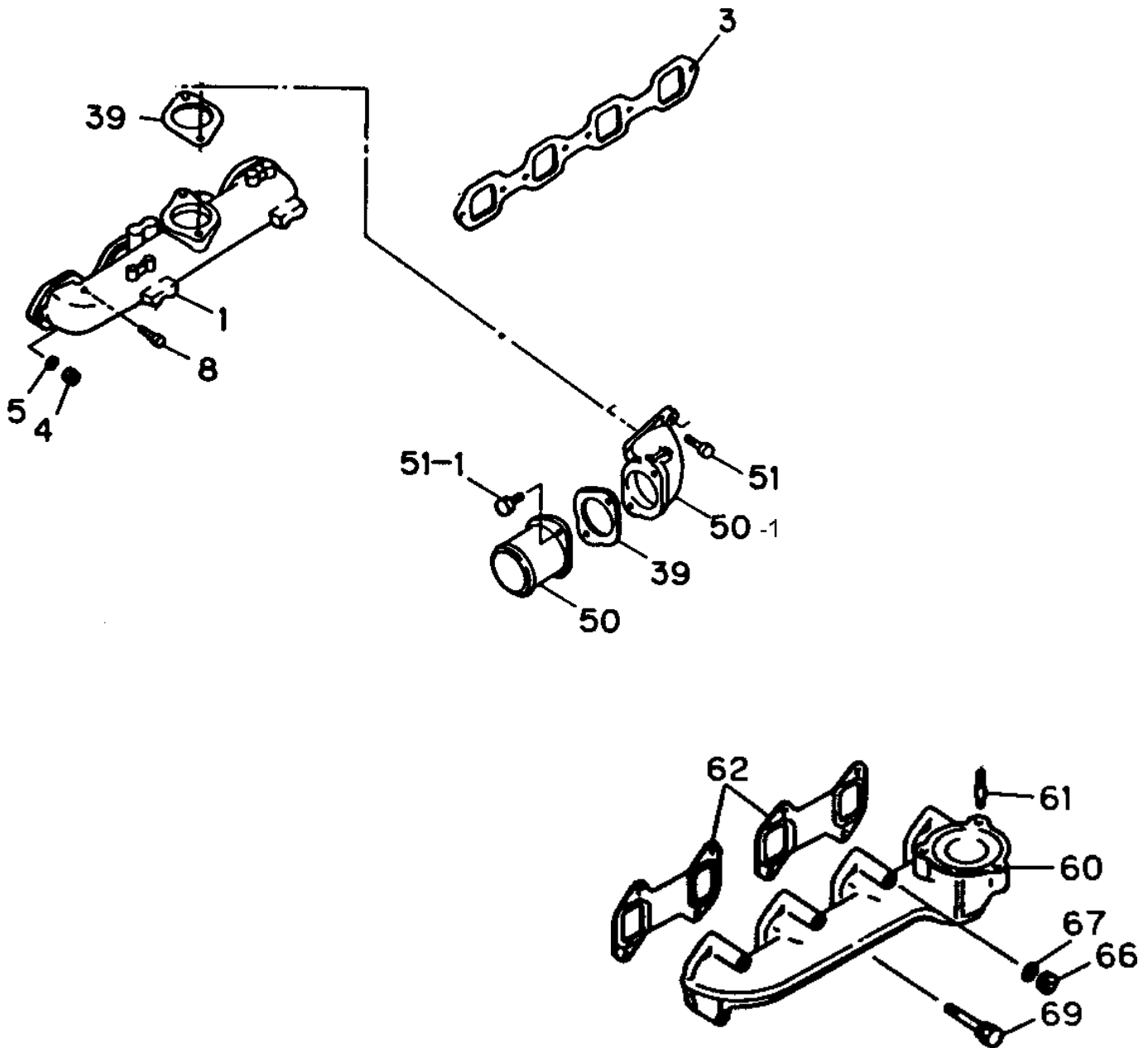

ISUZU 4BD1 — INTAKE AND EXHAUST ASSY.

INTAKE AND EXHAUST ASSY.

<u>NO.</u>	<u>PART NO.</u>	<u>PART NAME</u>	<u>QTY.</u>	<u>REMARKS</u>
1	5141112070	INTAKE MANIFOLD	1	
3	8970241220	GASKET, INTAKE	1	REPLACES 8943632700
4	1094400401	NUT	2	REPLACES 9091104080
5	1099851770	LOCKWASHER	2	REPLACES 9091505080
8	0500408250	BOLT	6	
39	8970225710	PACKING	2	REPLACES 5096370281
50	5141111160	INTAKE PIPE	1	
50-1	5141112360	INTAKE PIPE	1	REPLACES 5141111970
51	0501510300	BOLT	2	
51-1	0500510300	BOLT	2	
60	5141410360	EXHAUST MANIFOLD	1	
61	5093020020	STUD, EXHAUST	3	
62	8944046100	GASKET, EXHAUST	2	REPLACES 5141450040
66	1094400401	NUT	5	REPLACES 9091104080
67	1099851770	LOCKWASHER	5	REPLACES 9091505080
69	8942059871	BOLT, L=75	2	
	0500408600	BOLT, FIXED	1	

ISUZU 4BD1 — FUEL INJECTION ASSY.

FUEL INJECTION ASSY.

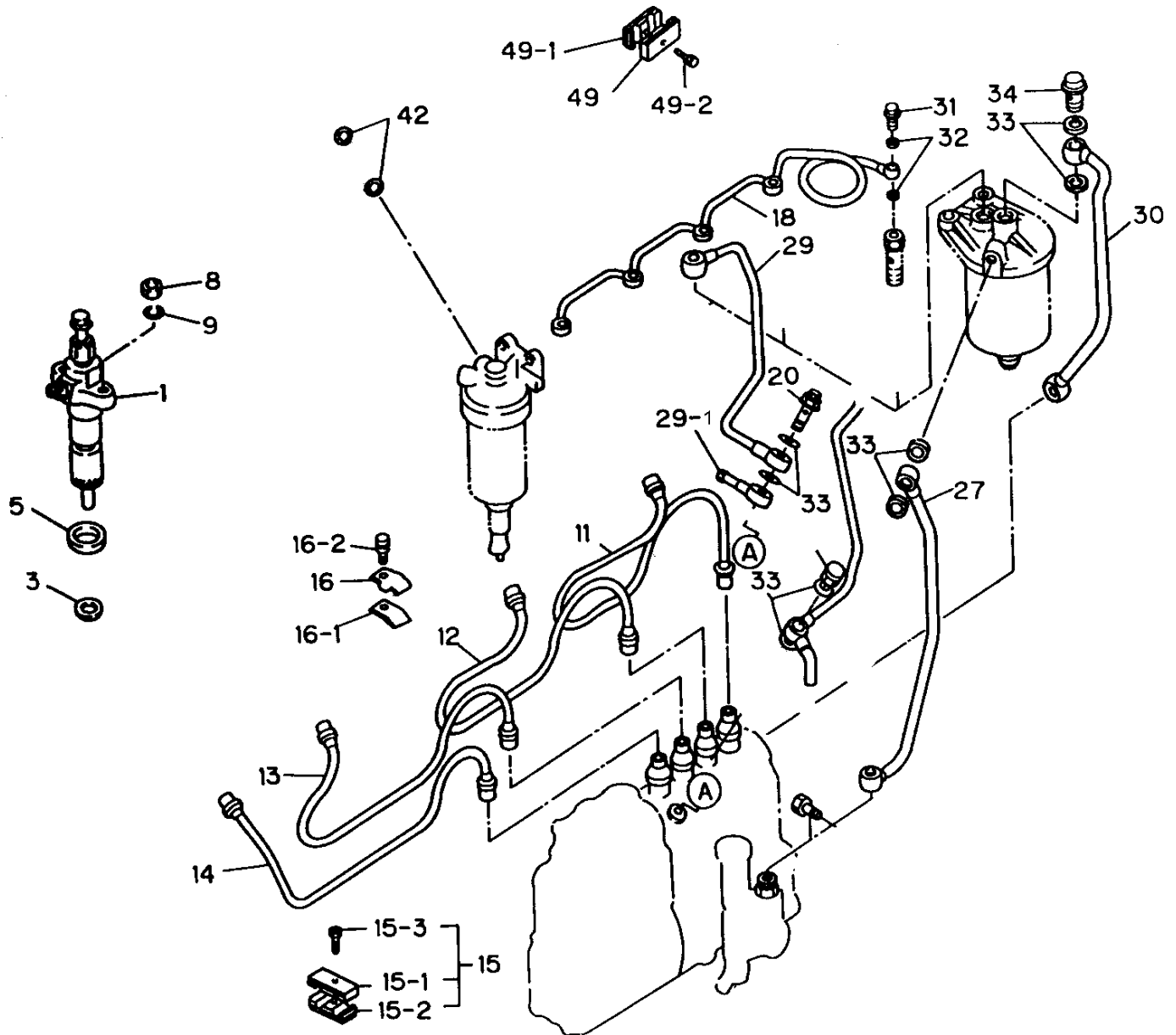

ISUZU 4BD1 — FUEL INJECTION ASSY.

FUEL INJECTION ASSY.

<u>NO.</u>	<u>PART NO.</u>	<u>PART NAME</u>	<u>QTY.</u>	<u>REMARKS</u>
1	5153001032	NOZZLE	4	
3	1153150131	PACKING	4	REPLACES 5153150030
5	9153390510	DUST COVER	4	
8	1094400401	NUT	8	REPLACES 9091104080
9	1099851770	LOCKWASHER	8	REPLACES 9091505080
11	8944636740	PIPE, NO. 1	1	
12	8944636750	PIPE, NO. 2	1	
13	8944636760	PIPE, NO. 3	1	
14	8944636770	PIPE, NO. 4	1	
15	5154190131	CLIP ASSY., D6X2	3	INCL. ITEMS W/#
15-1#	9154196130	CLIP, A	3	
15-2#	9154196140	CLIP, B	3	
15-3#		BOLT	3	NOT SOLD SEPARATELY FROM KIT
16	5154190040	CLIP, INTAKE MANIFOLD	1	
16-1	5154190051	CLIP, INTAKE MANIFOLD	1	
16-2	0501406160	BOLT	1	
18	5154112290	PIPE	1	
20	5132600101	OVERFLOW VALVE ASSY.	1	
27	5154115730	PIPE	1	
29	5154118580	FILTER LEAK PIPE ASSY.	1	
29-1	5154115680	EYE JOINT	1	REPLACES 5154112231
30	5154116030	FILTER PIPE ASSY.	1	
31	9099063141	BOLT	1	
32	9095714080	PACKING, GROMMET	2	
33	9095720140	PACKING, FUEL PIPE	6	
34	1095751460	BOLT	2	REPLACES 9099063251
42	9095720140	PACKING	3	
49	5097091030	CLIP A	2	
49-1	9097161240	CLIP B	2	REPLACES 5097091040
49-2	0500406250	CLIP BOLT	2	

ISUZU 4BD1 — ENGINE FOOT ASSY.

ENGINE FOOT ASSY.

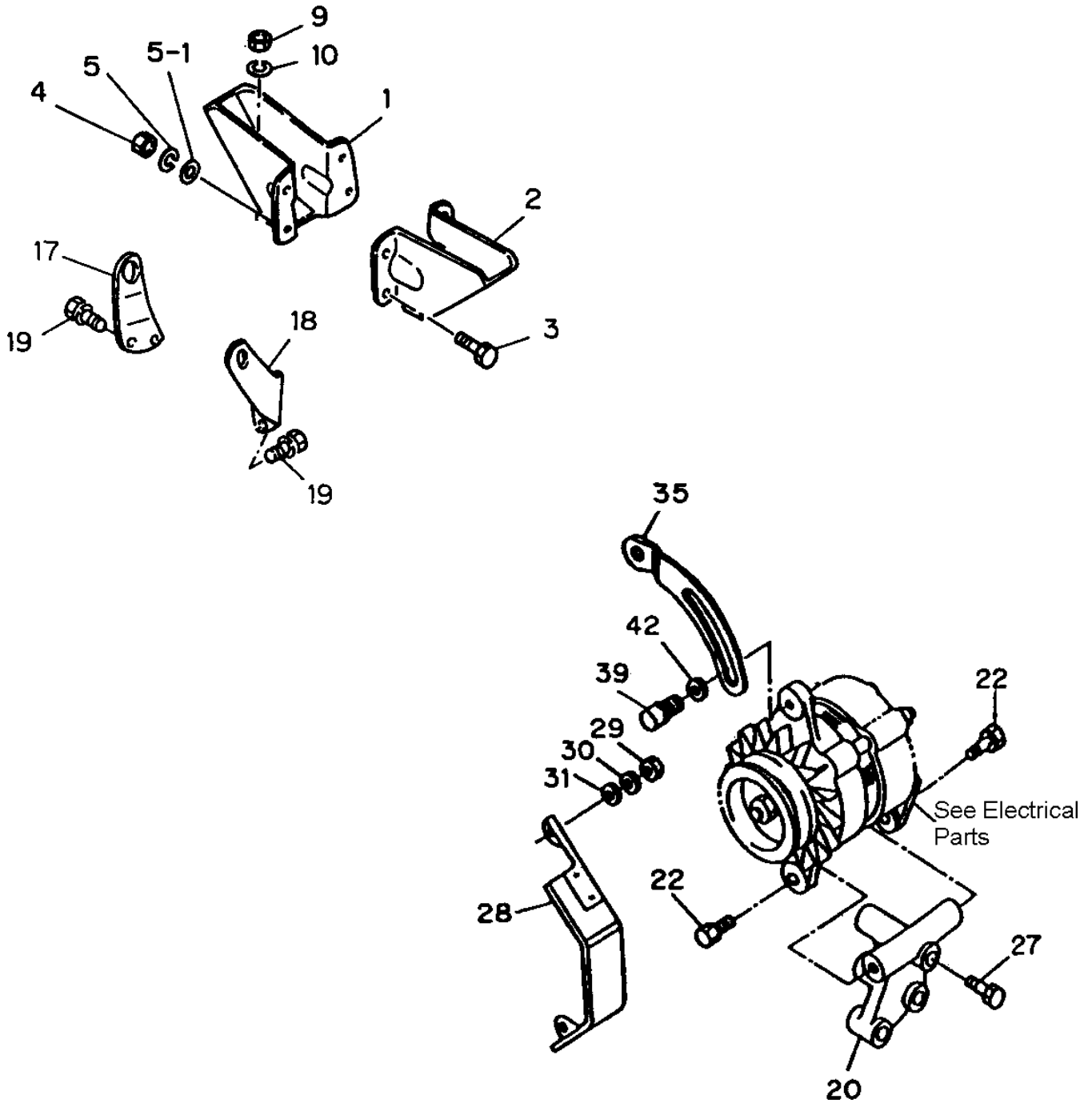

ISUZU 4BD1 — ENGINE FOOT ASSY.

ENGINE FOOT ASSY.

<u>NO.</u>	<u>PART NO.</u>	<u>PART NAME</u>	<u>QTY.</u>	<u>REMARKS</u>
1	9117712470	FOOT, FRONT RIGHT	1	
2	9117712480	FOOT, FRONT LEFT	1	
3	8943134650	BOLT	7	
4	9091105100	NUT	1	
5	030210250	LOCKWASHER	1	REPLACES 9091505100
17	5117770080	HANGER, FRONT	1	
18	9117778050	HANGER, R. REAR	1	
19	0500410200	BOLT	2	
20	5197110620	BRACKET	1	
22	0501408350	BOLT	1	
	0501408400	BOLT	1	
27	0500410000	BOLT	1	
27	0500410450	BOLT	1	
	5090300101	BOLT, L=75	1	
28	8943717120	COVER, PULLEY	1	
29	8942790500	NUT	1	REPLACES 9091105080
30	1099851770	LOCKWASHER	1	REPLACES 9091505080
31	9091606080	PLAIN WASHER	1	
35	5136740320	PLATE	1	
39	0500408400	BOLT	1	
42	9091647080	PLAIN WASHER	1	

ENGINE CONTROL ASSY.

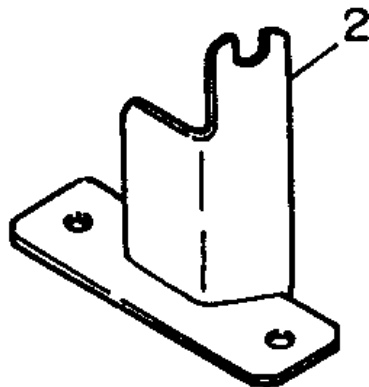

ISUZU 4BD1 — ENGINE CONTROL ASSY.

ENGINE CONTROL ASSY.

<u>NO.</u>	<u>PART NO.</u>	<u>PART NAME</u>	<u>QTY.</u>	<u>REMARKS</u>
2	5197890041	BRACKET	1	REPLACES 5197890040

ISUZU 4BD1 — INJECTION PUMP ASSY.

INJECTION PUMP ASSY.

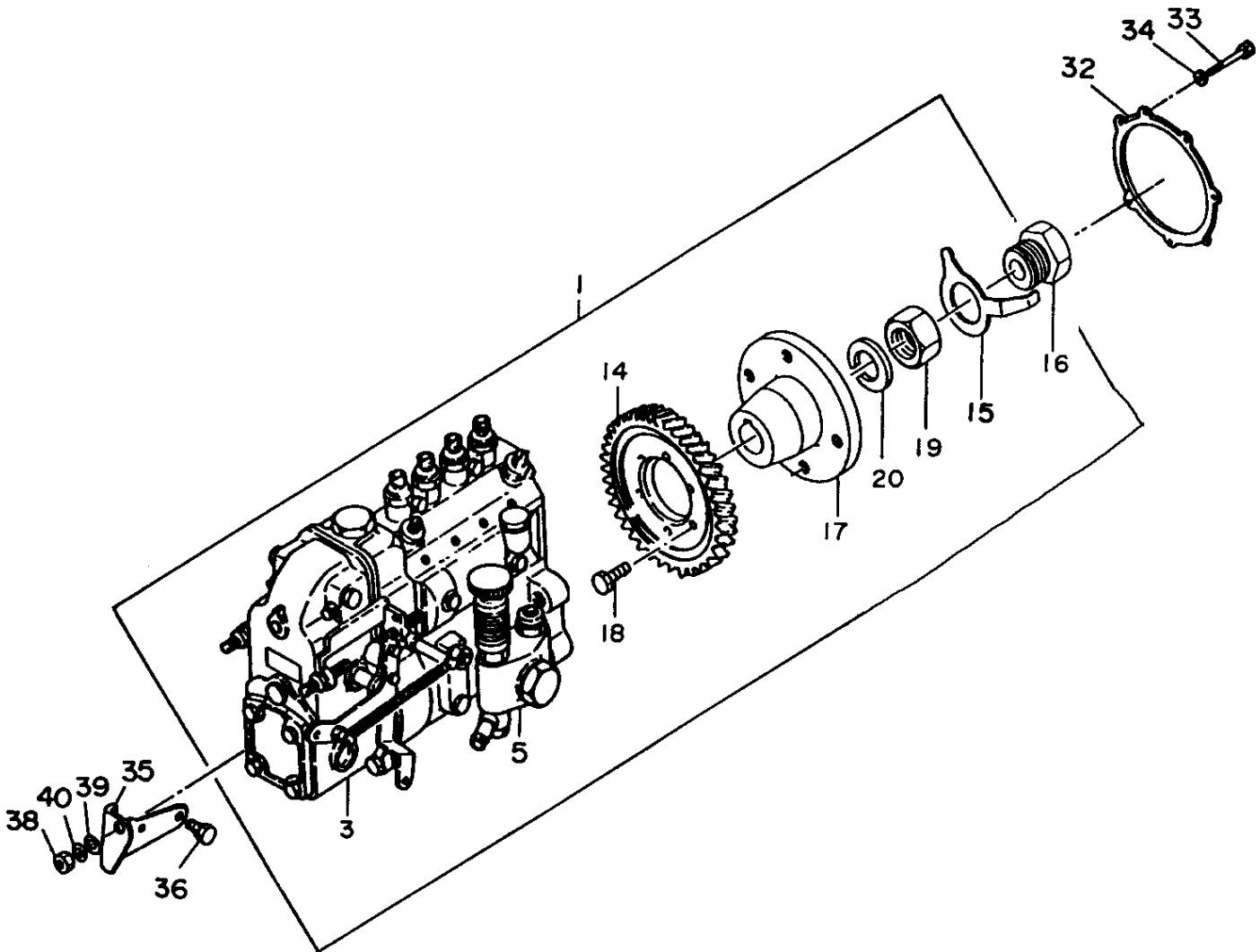

ISUZU 4BD1 — INJECTION PUMP ASSY.

INJECTION PUMP ASSY.

NO.	PART NO.	PART NAME	QTY.	REMARKS
1	8943440260	INJECTION PUMP ASSY.	1	INCL. ITEMS W/#
3#	8943440280	GOVERNOR ASSY.	1	
5#	8941327042	FEED PUMP ASSY.	1	REPLACES 8941327040
14#	5125240890	GEAR	1	REPLACES 5125240650
15#	1156192450	PLATE	1	
16#	9096620070	BOLT	1	
17#	5157810030	COUPLING	1	
18#	8944575170	BOLT	6	
19#	9884105020	NUT	1	
20#	5156190480	LOCK WASHER	1	
32	1113190090	PACKING	1	
33	8941500451	BOLT	7	REPLACES 5090000841
35	5197510150	BRACKET	1	
36	0500410250	BOLT	2	
38	9091105100	NUT	1	
39	9091645100	PLAIN WASHER	1	REPLACES 9091605100
40	030210250	LOCK WASHER	1	REPLACES 9091505100

ISUZU 4BD1 — ELECTRICAL COMPONENTS ASSY.

ELECTRICAL COMPONENTS ASSY.

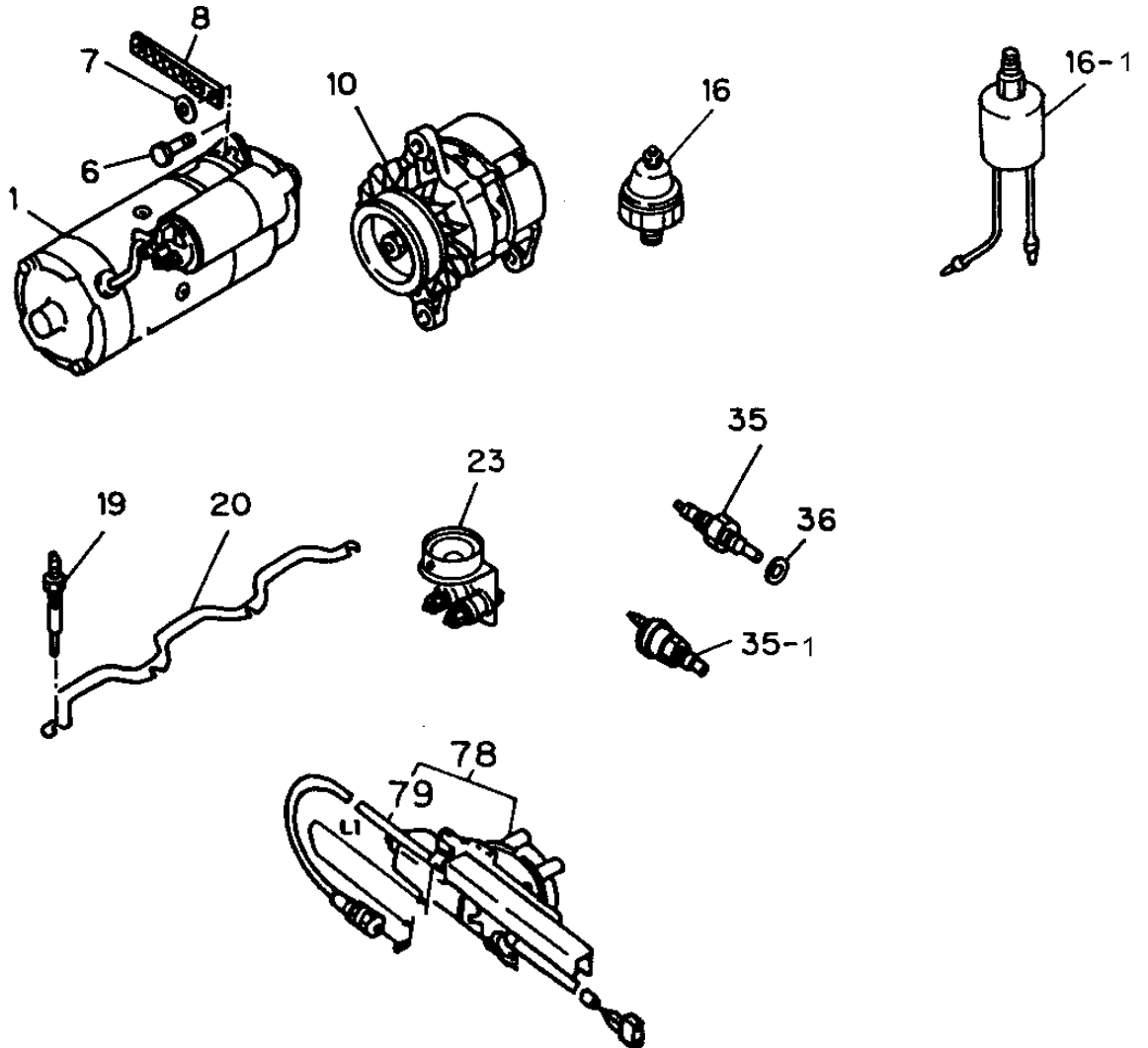

ISUZU 4BD1 — ELECTRICAL COMPONENTS ASSY.

ELECTRICAL COMPONENTS ASSY.

<u>NO.</u>	<u>PART NO.</u>	<u>PART NAME</u>	<u>QTY.</u>	<u>REMARKS</u>
1	1811001910	STARTER ASSY	1	
6	0500512280	BOLT	1	
6	0500512350	BOLT	2	
7	9091605120	PLAIN WASHER	1	
8	9829315110	CABLE ASSY.	1	
10	5812002121	ALTERNATOR ASSY.	1	
16	9827200690	OIL PRESS. WARNING SW.	1	
16-1	5824100160	OIL PRESS. WARNING SW.	1	
19	1825130430	GLOW PLUG (24V)	4	REPLACES 9825139288
20	5197320021	CONNECTOR	1	REPLACES 5197320020
23	9825300460	RESISTANCE CONTROLLER	1	
35	5824500141	OVERHEAT SWITCH, M16	1	
35-1	8970299880	OVERHEAT SWITCH, 3/8	1	
78	1819001931	STOP ASSY.	1	INCL. ITEM W/%; REPLACES
	1819000161			
79%	1828490430	CABLE ASSY.	1	

ISUZU 4BD1 — FEED PUMP COMP. ASSY.

FEED PUMP COMP. ASSY.

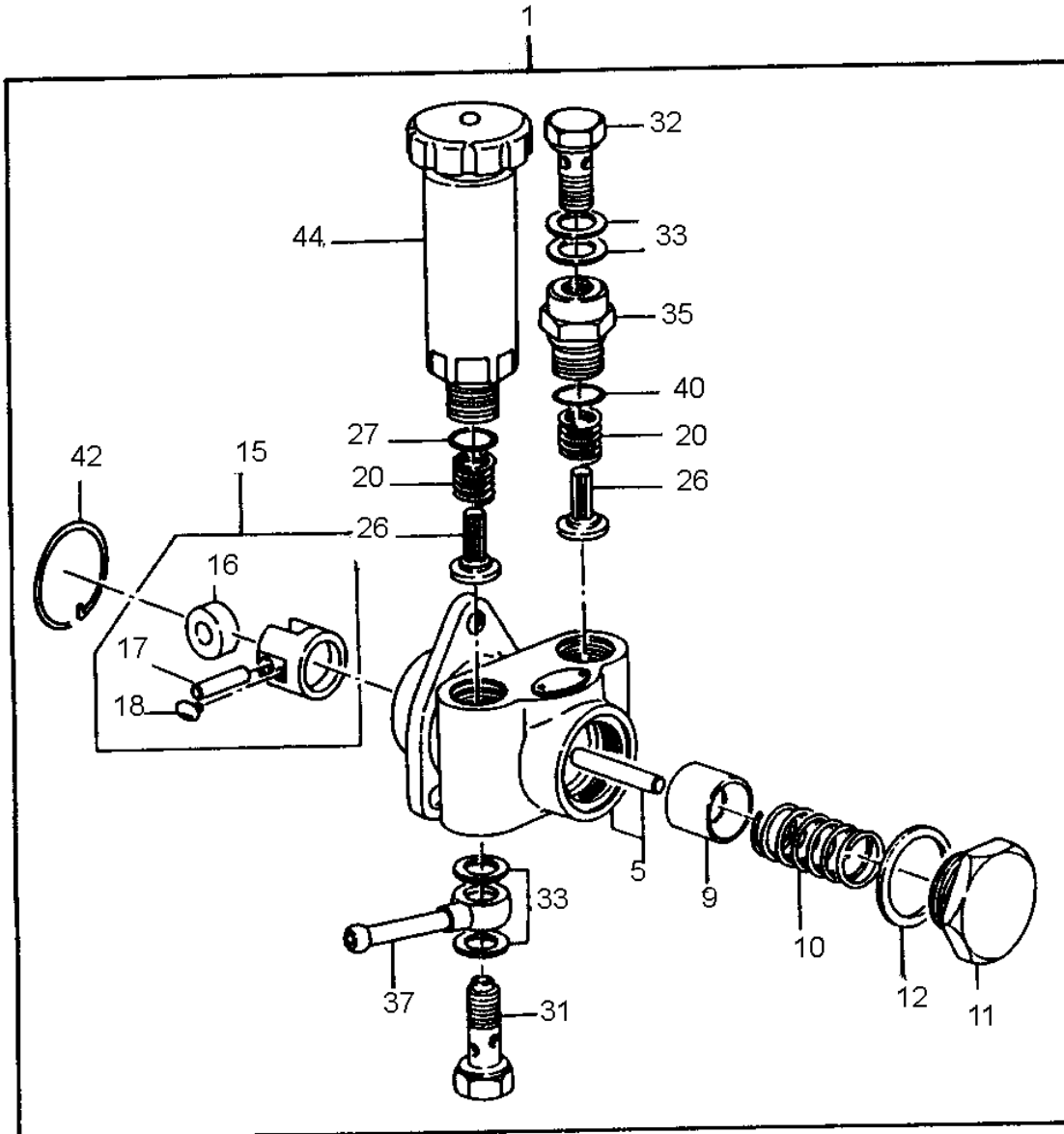

ISUZU 4BD1 — FEED PUMP COMP. ASSY.

FEED PUMP COMP. ASSY.

<u>NO.</u>	<u>PART NO.</u>	<u>PART NAME</u>	<u>QTY.</u>	<u>REMARKS</u>
1	8941327042	FEED PUMP ASSY.	1	INCL. ITEMS W/ #; REPLACES 8941327040
5#	5157510120	PUMP HOUSING	1	
9#	9813512050	PISTON	1	
10#	9813513020	SPRING	1	
11#	9813550230	PLUG	1	
12#	9813550350	GASKET	1	
15#	5157540010	TAPPET ASSY.	1	INCL. ITEMS W/%
16#%	9813514030	ROLLER	1	
17#%	9813514100	PIN	1	
18#%	1157590020	GUIDE	2	
20#	9813517020	SPRING	2	
26#	9813516020	VALVE	2	
27#	1156290650	O RING	1	REPLACES 1096230160
31#	5157590270	BOLT	1	
32#	1156190820	BOLT	1	
33#	1157590010	GASKET	1	
35#	1157590030	ADAPTER	1	
37#	5157590120	JOINT	1	
40#	1156290650	O RING	1	REPLACES 1096230160
42#	9813550250	SNAP RING	1	
44#	1157610060	PRIMING PUMP ASSY.	1	REPLACES 8941311300

NOZZLE ASSY.

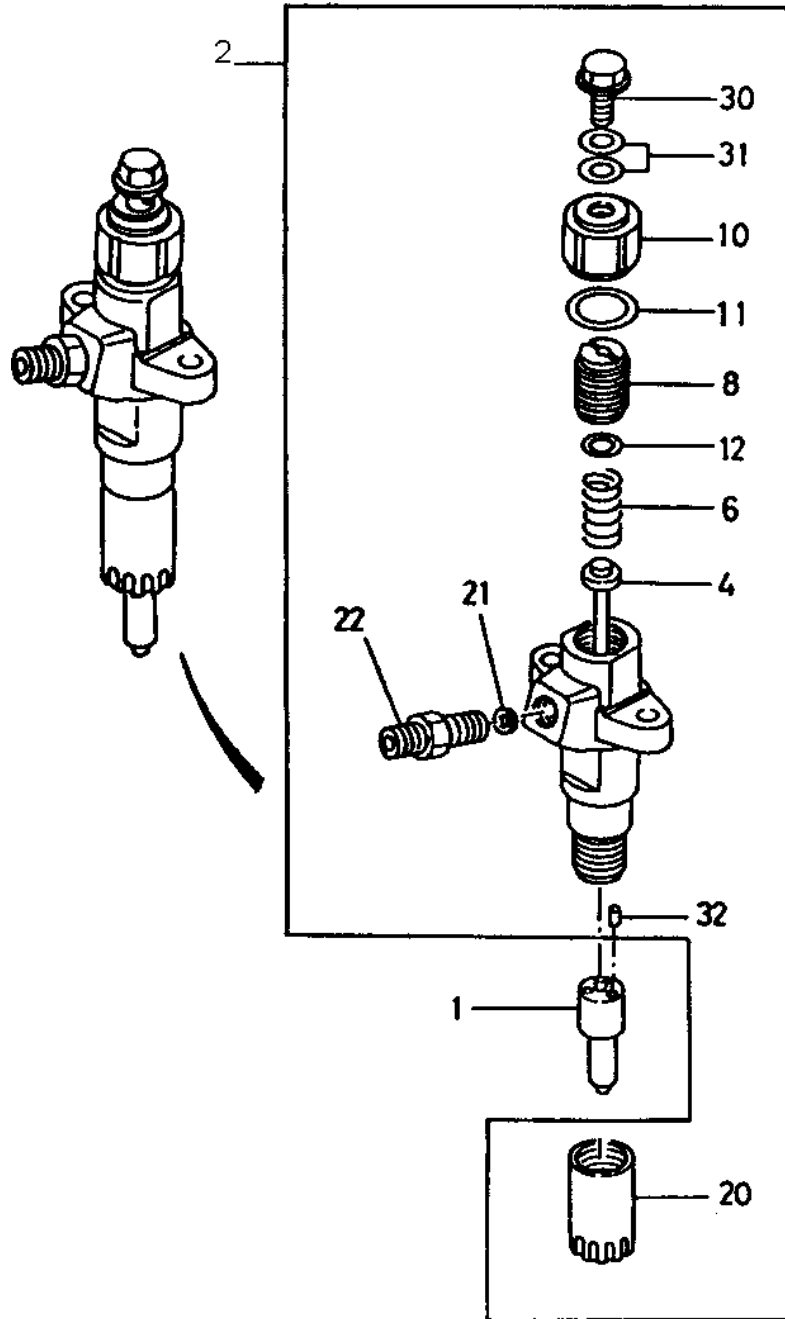

NOZZLE ASSY.

<u>NO.</u>	<u>PART NO.</u>	<u>PART NAME</u>	<u>QTY.</u>	<u>REMARKS</u>
1	5153110191	INJ. NOZZLE	4	REPLACES 5153110190
2	1153300941	HOLDER ASSY.	4	INCL. ITEMS W/#
4#	5153410010	PUSH ROD	4	
6#	9153430130	SPRING	4	
8#	5153450010	ADJ. SCREW	4	
10#	5153320100	NUT	4	
11#	9153390560	GASKET	4	
12#	9153390570	WASHER	4	
20#	1153320170	RETAINING NUT	4	
21#	5153390030	GASKET	4	
22#	5153510010	CONNECTOR	4	
30#	1096750371	BOLT	8	REPLACES 1153390090
31#	1153390100	GASKET	8	
32#	9153470030	PIN	8	

OIL FILTER ASSY.

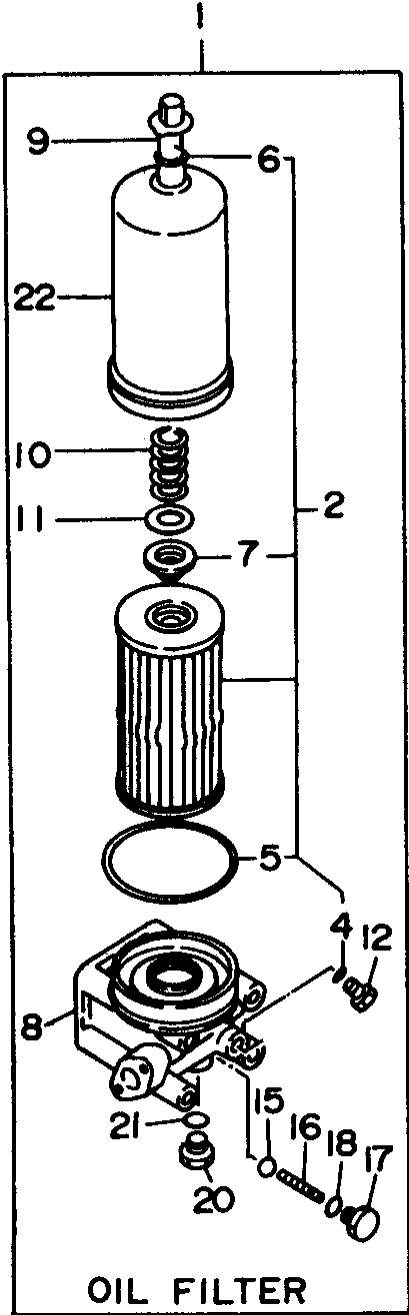

OIL FILTER ASSY.

<u>NO.</u>	<u>PART NO.</u>	<u>PART NAME</u>	<u>QTY.</u>	<u>REMARKS</u>
1	5132002262	OIL FILTER ASSY.	1	INCL. ITEMS W/#
2#	1878102201	OIL FILTER ELEMENT KIT	1	INCL. ITEMS W/&
4#&	9097205550	PACKING	1	REPLACES 9099209780
5#&	5096230670	PACKING	1	
6#&	9099211950	PACKING	1	
7#&	9132490090	PACKING, UPPER	1	
8#	5132120681	BODY	1	
9#	9132316020	BOLT	1	
10#	9099410980	SPRING	1	
11#	9132390310	SEAT	1	
12#	9098621170	DRAIN PLUG	1	
15#	9000975270	OVER FLOW VALVE	1	
16#	9099408600	SPRING	1	
17#	8941326650	VALVE PLUG	1	
18#	9099208410	PACKING	1	REPLACES 9099205260
20#	9132260110	PLUG	1	
21#	9099208410	PACKING	1	REPLACES 9099205260
22#	5132110201	CASE	1	

ISUZU 4BD1 — FUEL FILTER ASSY.

FUEL FILTER ASSY.

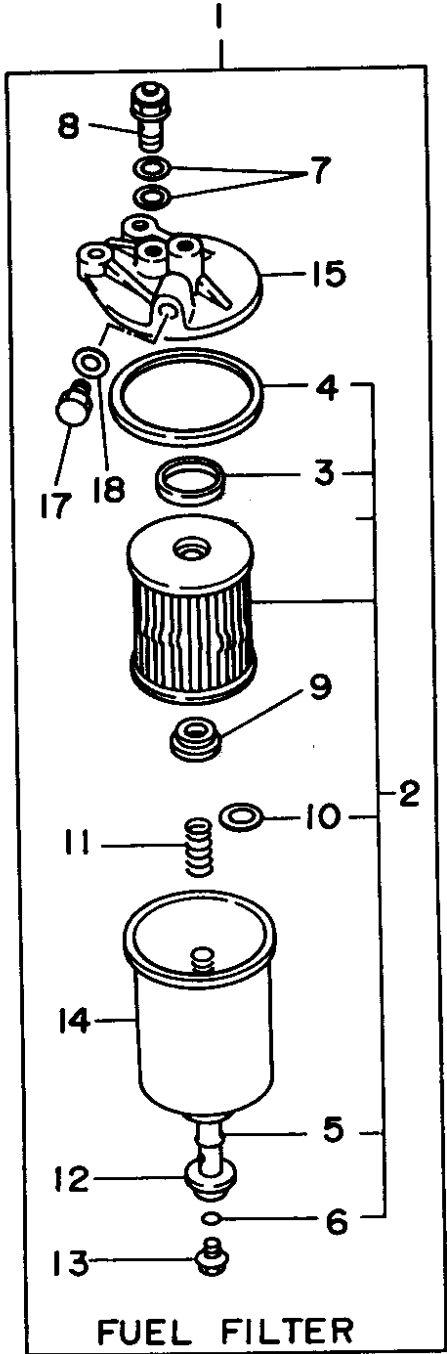

ISUZU 4BD1 — FUEL FILTER ASSY.

FUEL FILTER ASSY.

<u>NO.</u>	<u>PART NO.</u>	<u>PART NAME</u>	<u>QTY.</u>	<u>REMARKS</u>
1	9132004193	FUEL FILTER ASSY.	1	INCL. ITEMS W/#
2#	5878100500	ELEMENT KIT	1	INCL. ITEMS W/%
3#%	9099203270	O RING ELEMENT, UPPER	1	
4#%	9132136010	PACKING	1	
5#	9099208410	O RING	1	
6#%	5096230241	O RING	1	
7#	9095720140	PACKING	2	
8#	1132600470	VALVE	1	
9#	9099203260	PACKING	1	
10#%	9098518100	SPRING SEAT	1	
11#	9099409010	ELEMENT SPRING	1	
12#	9132310660	BOLT	1	
13#	9098620680	DRAIN PLUG	1	
14#	9132111071	CASE	1	
15#	9132128040	COVER	1	

ENGINE ACCESSORIES

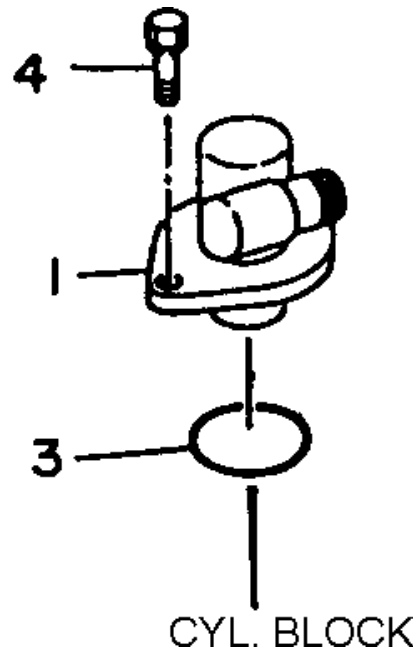

ISUZU 4BD1 — ENGINE ACCESSORIES

ENGINE ACCESSORIES

<u>NO.</u>	<u>PART NO.</u>	<u>PART NAME</u>	<u>QTY.</u>	<u>REMARKS</u>
1	8944533001	TACHOMETER DRIVE ASSY. ...	1	REPLACES 8944533000
3	1096234650	PACKING	1	
4	0500408200	BOLT	2	

PAYMENT TERMS

Terms of payment for parts are net 10 days.

FREIGHT POLICY

All parts orders will be shipped collect or prepaid with the charges added to the invoice. All shipments are F.O.B. point of origin. Multiquip's responsibility ceases when a signed manifest has been obtained from the carrier, and any claim for shortage or damage must be settled between the consignee and the carrier.

MINIMUM ORDER

The minimum charge for orders from Multiquip is \$15.00 net. Customers will be asked for instructions regarding handling of orders not meeting this requirement.

RETURNED GOODS POLICY

Return shipments will be accepted and credit will be allowed, subject to the following provisions:

1. A Returned Material Authorization must be approved by Multiquip prior to shipment.
2. To obtain a Return Material Authorization, a list must be provided to Multiquip Parts Sales that defines item numbers, quantities, and descriptions of the items to be returned.
 - a. The parts numbers and descriptions must match the current parts price list.
 - b. The list must be typed or computer generated.
 - c. The list must state the reason(s) for the return.
 - d. The list must reference the sales order(s) or invoice(s) under which the items were originally purchased.
 - e. The list must include the name and phone number of the person requesting the RMA.
3. A copy of the Return Material Authorization must accompany the return shipment.

4. Freight is at the sender's expense. All parts must be returned freight prepaid to Multiquip's designated receiving point.
5. Parts must be in new and resalable condition, in the original Multiquip package (if any), and with Multiquip part numbers clearly marked.
6. The following items are not returnable:
 - a. Obsolete parts. (If an item is listed in the parts price book as being replaced by another item, it is obsolete.)
 - b. Any parts with a limited shelf life (such as gaskets, seals, "O" rings, and other rubber parts) that were purchased more than six months prior to the return date.
 - c. Any line item with an extended dealer net price of less than \$5.00.
 - d. Special order items.
 - e. Electrical components.
 - f. Paint, chemicals, and lubricants.
 - g. Decals and paper products.
 - h. Items purchased in kits.
7. The sender will be notified of any material received that is not acceptable.
8. Such material will be held for 5 working days from notification, pending instructions. If a reply is not received within 5 days, the material will be returned to the sender at his expense.
9. Credit on returned parts will be issued at dealer net price at time of the original purchase, less a 15% restocking charge.
10. In cases where an item is accepted for which the original purchase document can not be determined, the price will be based on the list price that was effective twelve months prior to the RMA date.
11. Credit issued will be applied to future purchases only.

PRICING AND REBATES

Prices are subject to change without prior notice. Price changes are effective on a specific date and all orders received on or after that date will be billed at the revised price. Rebates for price declines and added charges for price increases will not be made for stock on hand at the time of any price change.

Multiquip reserves the right to quote and sell direct to Government agencies, and to Original Equipment Manufacturer accounts who use our products as integral parts of their own products.

SPECIAL EXPEDITING SERVICE

A \$20.00 to \$50.00 surcharge will be added to the invoice for special handling including bus shipments, insured parcel post or in cases where Multiquip must personally deliver the parts to the carrier.

LIMITATIONS OF SELLER'S LIABILITY

Multiquip shall not be liable here under for damages in excess of the purchase price of the item with respect to which damages are claimed, and in no event shall Multiquip be liable for loss of profit or good will or for any other special, consequential or incidental damages.

LIMITATION OF WARRANTIES

No warranties, express or implied, are made in connection with the sale of parts or trade accessories nor as to any engine not manufactured by Multiquip. Such warranties made in connection with the sale of new, complete units are made exclusively by a statement of warranty packaged with such units, and Multiquip neither assumes nor authorizes any person to assume for it any other obligation or liability whatever in connection with the sale of its products. A part from such written statement of warranty, there are no warranties, express, implied or statutory, which extend beyond the description of the products on the face hereof.

PARTS AND OPERATION MANUAL

HERE'S HOW TO GET HELP

*PLEASE HAVE THE MODEL AND SERIAL NUMBER
ON-HAND WHEN CALLING*

PARTS DEPARTMENT

800/427-1244 or 310/537-3700

FAX: 800/672-7877 or 310/637-3284

SERVICE DEPARTMENT

800/835-2551 or 310/537-3700

FAX: 310/638-8046

WARRANTY DEPARTMENT

800/835-2551 or 310/537-3700

FAX: 310/638-8046

MAIN

800/421-1244 or 310/537-3700

FAX: 310/537-3927

© COPYRIGHT 2001, MULTIQIP INC.



MULTIQIP INC.

18910 WILMINGTON AVE.
CARSON, CALIFORNIA 90746
310-537-3700
800-421-1244
FAX: 310-537-3927

PARTS DEPARTMENT:

800-427-1244
FAX: 800-672-7877

SERVICE DEPARTMENT:

800-835-2551
FAX: 310-638-8046

E-mail: mq@multiquip.com • **www:** www.multiquip.com