

OPERATION AND PARTS MANUAL



MQ POWER **WHISPERWATT™ SERIES** **MODEL DCA20SPXU2** **60HZ GENERATOR** **(ISUZU BV-4LE2 DIESEL ENGINE)**



PARTS LIST NO. M1870301404

NOTICE

This generator is manufactured for **SERVPRO®** by Multiquip, Inc.

Revision #0 (09/23/13)

THIS MANUAL MUST ACCOMPANY THE EQUIPMENT AT ALL TIMES.

 WARNING 
CALIFORNIA — Proposition 65 Warning
Diesel engine exhaust and some of its constituents are known to the State of California to cause cancer, birth defects and other reproductive harm.

REPORTING SAFETY DEFECTS

If you believe that your vehicle has a defect that could cause a crash or could cause injury or death, you should immediately inform the National Highway Traffic Safety Administration (NHTSA) in addition to notifying Multiquip at 1-800-421-1244.

If NHTSA receives similar complaints, it may open an investigation, and if it finds that a safety defect exists in a group of vehicles, it may order a recall and remedy campaign. However, NHTSA cannot become involved in individual problems between you, your dealer, or Multiquip.

To contact NHTSA, you may either call the Vehicle Safety Hotline toll-free at 1-888-327-4236 (TTY: 1-800-424-9153), go to <http://www.nhtsa.dot.gov>; or write to:

Administrator
NHTSA
1200 New Jersey Avenue S.E.
Washington, DC 20590

You can also obtain information about motor vehicle safety from <http://www.safecar.gov>.

TABLE OF CONTENTS

DCA20SPXU2 60Hz Generator

Proposition 65 Warning	2
Reporting Safety Defects.....	3
Table Of Contents.....	4
Parts Ordering Procedures.....	5
Safety Information	6-11
Specifications	12
Dimensions.....	13
Installation	14
Installation	15
General Information.....	16
Generator Major Components	17
Trailer Major Components	18
Generator Control Panel.....	19
Engine Control Panel.....	20-21
Output Terminal Panel Familiarization	22-24
Load Application/Generator Output.....	25
Output Terminal Panel Connections	26
Inspection/Setup.....	27-30
Generator Start-Up Procedure (Manual)	31-32
Generator Shut-Down Procedures	33-34
Maintenance.....	35-38
Trailer Maintenance	39-40
Trailer Guidelines.....	41-55
Generator Wiring Diagram.....	56
Engine Wiring Diagram.....	57
Jacket Water Heater Wiring Diagram.....	58
Troubleshooting (Generator).....	59
Troubleshooting (Engine).....	60-61
Explanation Of Code In Remarks Column.....	62
Suggested Spare Parts	63

Component Drawings

Generator Assembly.....	64-65
Control Box Assembly.....	66-69
Engine And Radiator Assembly.....	70-73
Output Terminal Assembly.....	74-75
Battery Assembly.....	76-77
Muffler Assembly	78-79
Fuel Tank Assembly (Internal)	80-81
Fuel Tank Assembly (Trailer Mounted)	82-83
Trailer Assembly	84-85
Battery Charger Assembly	86-87
Jacket Water Heater Assembly	88-89
Enclosure Assembly.....	90-93
Rubber Seals Assembly	94-95
Nameplate And Decals	96-97
Terms And Conditions Of Sale — Parts	98
Servpro® Warranty/RMA	99

PARTS ORDERING PROCEDURES

Ordering parts has never been easier! Choose from three easy options:

Effective:
January 1st, 2006



Order via Internet (Dealers Only):

Order parts on-line using Multiquip's SmartEquip website!

- View Parts Diagrams
- Order Parts
- Print Specification Information



If you have an MQ Account, to obtain a Username and Password, E-mail us at: parts@multiquip.com.

To obtain an MQ Account, contact your District Sales Manager for more information.

Goto www.multiquip.com and click on **Order Parts** to log in and save!

Use the **internet** and qualify for a **5% Discount** on *Standard orders* for all orders which include complete part numbers.*

Note: Discounts Are Subject To Change



Order via Fax (Dealers Only):

All customers are welcome to order parts via Fax.

Domestic (US) Customers dial:
1-800-6-PARTS-7 (800-672-7877)

Fax your order in and qualify for a **2% Discount** on *Standard orders* for all orders which include complete part numbers.*

Note: Discounts Are Subject To Change



Order via Phone: Domestic (US) Dealers Call:
1-800-427-1244

Non-Dealer Customers:

Contact your local Multiquip Dealer for parts or call 800-427-1244 for help in locating a dealer near you.



International Customers should contact their local Multiquip Representatives for Parts Ordering information.

When ordering parts, please supply:

- | | |
|---|--|
| <input type="checkbox"/> Dealer Account Number | <input type="checkbox"/> Specify Preferred Method of Shipment: |
| <input type="checkbox"/> Dealer Name and Address | ✓ UPS/Fed Ex ✓ DHL |
| <input type="checkbox"/> Shipping Address (if different than billing address) | ■ Priority One ✓ Truck |
| <input type="checkbox"/> Return Fax Number | ■ Ground |
| <input type="checkbox"/> Applicable Model Number | ■ Next Day |
| <input type="checkbox"/> Quantity, Part Number and Description of Each Part | ■ Second/Third Day |

NOTICE

All orders are treated as *Standard Orders* and will ship the same day if received prior to 3PM PST.

WE ACCEPT ALL MAJOR CREDIT CARDS!



www.multiquip.com



SAFETY INFORMATION

Do not operate or service the equipment before reading the entire manual. Safety precautions should be followed at all times when operating this equipment. Failure to read and understand the safety messages and operating instructions could result in injury to yourself and others.

SAFETY MESSAGES

The four safety messages shown below will inform you about potential hazards that could injure you or others. The safety messages specifically address the level of exposure to the operator and are preceded by one of four words: **DANGER**, **WARNING**, **CAUTION** or **NOTICE**.

SAFETY SYMBOLS

 **DANGER**

Indicates a hazardous situation which, if not avoided, **WILL** result in **DEATH** or **SERIOUS INJURY**.

 **WARNING**

Indicates a hazardous situation which, if not avoided, **COULD** result in **DEATH** or **SERIOUS INJURY**.







 **CAUTION**

Indicates a hazardous situation which, if not avoided, **COULD** result in **MINOR** or **MODERATE INJURY**.

NOTICE

Addresses practices not related to personal injury.

Potential hazards associated with the operation of this equipment will be referenced with hazard symbols which may appear throughout this manual in conjunction with safety messages.

Symbol	Safety Hazard
	Lethal exhaust gas hazards
	Explosive fuel hazards
	Burn hazards
	Overspeed hazards
	Rotating parts hazards
	Pressurized fluid hazards
	Electric shock hazards

SAFETY INFORMATION

GENERAL SAFETY

⚠ CAUTION

- **NEVER** operate this equipment without proper protective clothing, shatterproof glasses, respiratory protection, hearing protection, steel-toed boots and other protective devices required by the job or city and state regulations.



- **NEVER** operate this equipment when not feeling well due to fatigue, illness or when under medication. 
- **NEVER** operate this equipment under the influence of drugs or alcohol.



- **ALWAYS** check the equipment for loosened threads or bolts before starting.
- **DO NOT** use the equipment for any purpose other than its intended purposes or applications.

NOTICE

- This equipment should only be operated by trained and qualified personnel 18 years of age and older.
- Whenever necessary, replace nameplate, operation and safety decals when they become difficult read.
- Manufacturer does not assume responsibility for any accident due to equipment modifications. Unauthorized equipment modification will void all warranties.

- **NEVER** use accessories or attachments that are not recommended by MQ Power for this equipment. Damage to the equipment and/or injury to user may result.

- **ALWAYS** know the location of the nearest **fire extinguisher**.



- **ALWAYS** know the location of the nearest **first aid kit**.



- **ALWAYS** know the location of the nearest phone or **keep a phone on the job site**. Also, know the phone numbers of the nearest **ambulance, doctor and fire department**. This information will be invaluable in the case of an emergency.

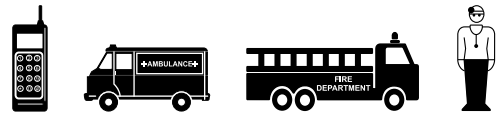

GENERATOR SAFETY

⚠ DANGER

- **NEVER** operate the equipment in an explosive atmosphere or near combustible materials. An explosion or fire could result causing severe **bodily harm or even death**.



⚠ WARNING

- **NEVER** disconnect any **emergency or safety devices**. These devices are intended for operator safety. Disconnection of these devices can cause severe injury, bodily harm or even death. Disconnection of any of these devices will void all warranties.

⚠ CAUTION

- **NEVER** lubricate components or attempt service on a running machine.

NOTICE

- **ALWAYS** ensure generator is on level ground before use.
- **ALWAYS** keep the machine in proper running condition.
- Fix damage to machine and replace any broken parts immediately.
- **ALWAYS** store equipment properly when it is not being used. Equipment should be stored in a clean, dry location out of the reach of children and unauthorized personnel

SAFETY INFORMATION

ENGINE SAFETY

DANGER

- The engine fuel exhaust gases contain poisonous carbon monoxide. This gas is colorless and odorless, and can cause death if inhaled.
- The engine of this equipment requires an adequate free flow of cooling air. **NEVER** operate this equipment in any enclosed or narrow area where free flow of the air is restricted. If the air flow is restricted it will cause injury to people and property and serious damage to the equipment or engine.

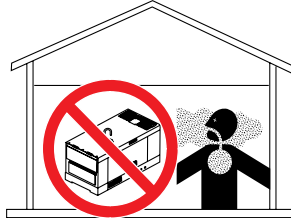

WARNING

- **DO NOT** place hands or fingers inside engine compartment when engine is running.
- **NEVER** operate the engine with heat shields or guards removed.
- Keep fingers, hands hair and clothing away from all moving parts to prevent injury.
- **DO NOT** remove the radiator cap while the engine is hot. High pressure boiling water will gush out of the radiator and severely scald any persons in the general area of the generator.
- **DO NOT** remove the coolant drain plug while the engine is hot. Hot coolant will gush out of the coolant tank and severely scald any persons in the general area of the generator.
- **DO NOT** remove the engine oil drain plug while the engine is hot. Hot oil will gush out of the oil tank and severely scald any persons in the general area of the generator.



CAUTION

- **NEVER** touch the hot exhaust manifold, muffler or cylinder. Allow these parts to cool before servicing equipment.



NOTICE

- **NEVER** run engine without an air filter or with a dirty air filter. Severe engine damage may occur. Service air filter frequently to prevent engine malfunction.
- **NEVER** tamper with the factory settings of the engine or engine governor. Damage to the engine or equipment can result if operating in speed ranges above the maximum allowable.
- Wet stacking is a common problem with diesel engines which are operated for extended periods with light or no load applied. When a diesel engine operates without sufficient load (less than 40% of the rated output), it will not operate at its optimum temperature. This will allow unburned fuel to accumulate in the exhaust system, which can foul the fuel injectors, engine valves and exhaust system, including turbochargers, and reduce the operating performance.



In order for a diesel engine to operate at peak efficiency, it must be able to provide fuel and air in the proper ratio and at a high enough engine temperature for the engine to completely burn all of the fuel.

Wet stacking does not usually cause any permanent damage and can be alleviated if additional load is applied to relieve the condition. It can reduce the system performance and increase maintenance. Applying an increasing load over a period of time until the excess fuel is burned off and the system capacity is reached usually can repair the condition. This can take several hours to burn off the accumulated unburned fuel.

- State Health Safety Codes and Public Resources Codes specify that in certain locations, spark arresters must be used on internal combustion engines that use hydrocarbon fuels. A spark arrester is a device designed to prevent accidental discharge of sparks or flames from the engine exhaust. Spark arresters are qualified and rated by the United States Forest Service for this purpose. In order to comply with local laws regarding spark arresters, consult the engine distributor or the local Health and Safety Administrator.

SAFETY INFORMATION

FUEL SAFETY

DANGER

- **DO NOT** start the engine near spilled fuel or combustible fluids. Diesel fuel is extremely flammable and its vapors can cause an explosion if ignited.
- **ALWAYS** refuel in a well-ventilated area, away from sparks and open flames.
- **ALWAYS** use extreme caution when working with **flammable** liquids.
- **DO NOT** fill the fuel tank while the engine is running or hot.
- **DO NOT** overfill tank, since spilled fuel could ignite if it comes into contact with hot engine parts or sparks from the ignition system.
- Store fuel in appropriate containers, in well-ventilated areas and away from sparks and flames.
- **NEVER** use fuel as a cleaning agent.
- **DO NOT** smoke around or near the equipment. Fire or explosion could result from fuel vapors or if fuel is spilled on a hot engine.



TOWING SAFETY

CAUTION

- Check with your local county or state safety towing regulations, in addition to meeting **Department of Transportation (DOT) Safety Towing Regulations**, before towing your generator.
- Refer to MQ Power trailer manual for additional safety information.
- In order to reduce the possibility of an accident while transporting the generator on public roads, **ALWAYS** make sure the trailer that supports the generator and the towing vehicle are mechanically sound and in good operating condition.
- **ALWAYS** shutdown engine before transporting



- Make sure the hitch and coupling of the towing vehicle are rated equal to, or greater than the trailer “gross vehicle weight rating.”
- **ALWAYS** inspect the hitch and coupling for wear. **NEVER** tow a trailer with defective hitches, couplings, chains, etc.
- Check the tire air pressure on both towing vehicle and trailer. **Trailer tires should be inflated to 50 psi cold.** Also check the tire tread wear on both vehicles.
- **ALWAYS** make sure the trailer is equipped with a **safety chain**.
- **ALWAYS** properly attach trailer’s safety chains to towing vehicle.
- **ALWAYS** make sure the vehicle and trailer directional, backup, brake and trailer lights are connected and working properly.
- DOT Requirements include the following:
 - Connect and test electric brake operation.
 - Secure portable power cables in cable tray with tie wraps.
- The maximum speed for highway towing is **55 MPH** unless posted otherwise. Recommended off-road towing is not to exceed **15 MPH** or less depending on type of terrain.
- Avoid sudden stops and starts. This can cause skidding, or jack-knifing. Smooth, gradual starts and stops will improve towing.
- Avoid sharp turns to prevent rolling.
- Trailer should be adjusted to a level position at all times when towing.
- Raise and lock trailer wheel stand in up position when towing.
- Place **chock blocks** underneath wheel to prevent **rolling** while parked.
- Place **support blocks** underneath the trailer’s bumper to prevent **tipping** while parked.
- Use the trailer’s swivel jack to adjust the trailer height to a level position while parked.

SAFETY INFORMATION

ELECTRICAL SAFETY

DANGER

- **DO NOT** touch output terminals during operation. Contact with output terminals during operation can cause **electrocution, electrical shock or burn.**



- The electrical voltage required to operate the generator can cause severe injury or even death through physical contact with live circuits. Turn generator and all circuit breakers **OFF** before performing maintenance on the generator or making contact with output terminals.

- **NEVER** insert any objects into the output receptacles during operation. This is extremely dangerous. The possibility exists of **electrical shock, electrocution or death.**



- Backfeed to a utility system can cause **electrocution** and/or property damage. **NEVER** connect the generator to a building's electrical system without a transfer switch or other approved device. All installations should be performed by a **licensed electrician** in accordance with all applicable laws and electrical codes. Failure to do so could result in electrical shock or burn, causing **serious injury or even death.**



Power Cord/Cable Safety

DANGER

- **NEVER** let power cords or cables **lay in water.**
- **NEVER stand in water** while AC power from the generator is being transferred to a load.
- **NEVER** use **damaged** or **worn** cables or cords when connecting equipment to generator. Inspect for cuts in the insulation.
- **NEVER** grab or touch a live power cord or cable with wet hands. The possibility exists of **electrical shock, electrocution or death.**

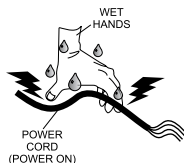

- Make sure power cables are securely connected to the generator's output receptacles. Incorrect connections may cause electrical shock and damage to the generator.

NOTICE

- **ALWAYS** make certain that proper power or extension cord has been selected for the job. See Cable Selection Chart in this manual.

Grounding Safety

DANGER

- **ALWAYS** make sure that electrical circuits are properly grounded to a suitable earth ground (ground rod) per the National Electrical Code (NEC) and local codes before operating generator. **Severe injury or death by electrocution** can result from operating an ungrounded generator.
- **NEVER** use gas piping as an electrical ground.

BATTERY SAFETY

DANGER

- **DO NOT** drop the battery. There is a possibility that the battery will explode.
- **DO NOT** expose the battery to open flames, sparks, cigarettes, etc. The battery contains combustible gases and liquids. If these gases and liquids come into contact with a flame or spark, an explosion could occur.



WARNING

- **ALWAYS** wear safety glasses when handling the battery to avoid eye irritation. The battery contains acids that can cause injury to the eyes and skin.
- Use well-insulated gloves when picking up the battery.
- **ALWAYS** keep the battery charged. If the battery is not charged, combustible gas will build up.
- **ALWAYS** recharge the battery in a well-ventilated environment to avoid the risk of a dangerous concentration of combustible gasses.



SAFETY INFORMATION

- If the battery liquid (dilute sulfuric acid) comes into contact with **clothing or skin**, rinse skin or clothing immediately with plenty of water.
- If the battery liquid (dilute sulfuric acid) comes into contact with **eyes**, rinse eyes immediately with plenty of water and contact the nearest doctor or hospital to seek medical attention.

CAUTION

- **ALWAYS** disconnect the **NEGATIVE battery terminal** before performing service on the generator.
- **ALWAYS** keep battery cables in good working condition. Repair or replace all worn cables.

ENVIRONMENTAL SAFETY/DECOMMISSIONING

NOTICE

Decommissioning is a controlled process used to safely retire a piece of equipment that is no longer serviceable. If the equipment poses an unacceptable and unreparable safety risk due to wear or damage or is no longer cost effective to maintain (beyond life-cycle reliability) and is to be decommissioned (demolition and dismantlement), be sure to follow rules below.

- **DO NOT** pour waste or oil directly onto the ground, down a drain or into any water source.
- Contact your country's Department of Public Works or recycling agency in your area and arrange for proper disposal of any electrical components, waste or oil associated with this equipment.
- When the life cycle of this equipment is over, remove battery and bring to appropriate facility for lead reclamation. Use safety precautions when handling batteries that contain sulfuric acid.
- When the life cycle of this equipment is over, it is recommended that the trowel frame and all other metal parts be sent to a recycling center.



Metal recycling involves the collection of metal from discarded products and its transformation into raw materials to use in manufacturing a new product.

Recyclers and manufacturers alike promote the process of recycling metal. Using a metal recycling center promotes energy cost savings.

EMISSIONS INFORMATION

NOTICE

The gasoline engine used in this equipment has been designed to reduce harmful levels of carbon monoxide (CO), hydrocarbons (HC) and nitrogen oxides (NOx) contained in diesel exhaust emissions.

This engine has been certified to meet US EPA Evaporative emissions requirements in the installed configuration.

Attempting to modify or make adjustments to the engine emission system by unauthorized personnel without proper training could damage the equipment or create an unsafe condition.

Additionally, modifying the fuel system may adversely affect evaporative emissions, resulting in fines or other penalties.

Emission Control Label

The emission control label is an integral part of the emission system and is strictly controlled by regulations.

The label must remain with the engine for its entire life.

If a replacement emission label is needed, please contact your authorized engine distributor.

SPECIFICATIONS

Table 1. Generator Specifications	
Model	DCA-20SPXU2
Type	Revolving field, self ventilated, open protected type synchronous generator
Armature Connection	Series
Phase	Single-Phase 3-Wire
Standby Output	22 kW (27.5 kVA)
Prime Output	20 kW (25.0 kVA)
Voltage	120/240V
Frequency	60 Hz
Speed	1800 rpm
Power Factor	1.0
Aux. AC Power	Single Phase, 60 Hz
Sound Level db (A) full Load at 23 ft. (7 meters)	63
Weight (No Fuel)	1,412 lbs. (640 kg.)
Weight (Fuel)	2,012 lbs. (913 kg.)

Table 2. Engine Specifications		
Model	ISUZU BV-4LE2 Tier 4i	
Type	4 cycle, water-cooled, direct injection, turbo-charged	
No. of Cylinders	4 cylinders	
Bore x Stroke	3.34 in. x 3.77 in. (85 mm x 96 mm)	
Displacement	133 cu. in. (2,179 cc)	
Rated Output	34.3 HP/1800 RPM	
Starting	Electric	
Coolant Capacity	1.74 gal. (6.6 liters)	
Lube Oil Capacity	2.25 gal. (8.5 liters)	
Fuel Type	#2 Diesel Fuel, Low Sulfur Diesel Fuel Only	
Fuel Tank Capacity	17 gal. (65 liters - Internal) 41 gal (155 liters External)	
Fuel Consumption	1.66 gal. (6.3 L)/hr at full load	1.21 gal. (4.6 L)/hr at 3/4 load
	0.85 gal. (3.2 L)/hr at 1/2 load	0.58 gal. (2.2 L)/hr at 1/4 load
Battery	12V 53Ah x 1	

Table 3. Trailer Specifications	
Model	TRLR50XF
Gross Vehicle Weight Rating	2,700 lbs. (1,225 kg)
Gross Axle Weight Rating	3,500 lbs. (1,588)
Axle/Suspension	Single/Leaf Spring
Tire Load rating	1,360 lbs. (617 kg ea.)
Wheel Bolt Pattern	5 Lug on 4.5 in.
Tongue Mounted Swivel Jack	1,000 lbs. (454 kg) Lift Capacity
Coupler Options	Adjustable 2" or 2-5/16" Ball and 3" Pintle Eye
Lights	DOT approved Tail, Stop, Turn, License Lights
Weight	510 lbs. (231.5 kg) No Fuel/801 lbs. (363.6 kg) With Fuel

DIMENSIONS

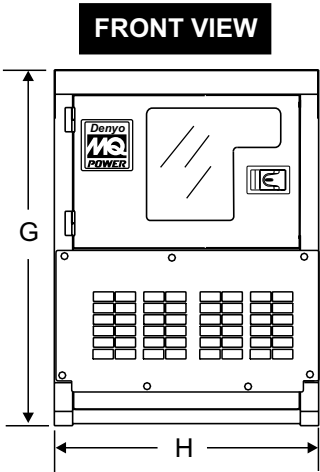
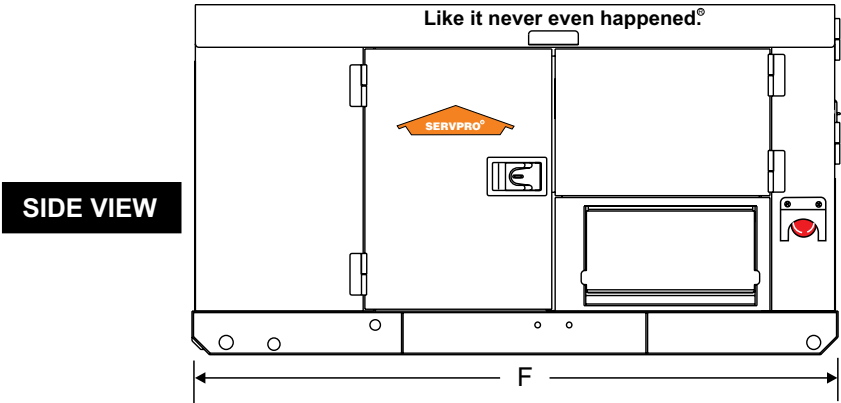
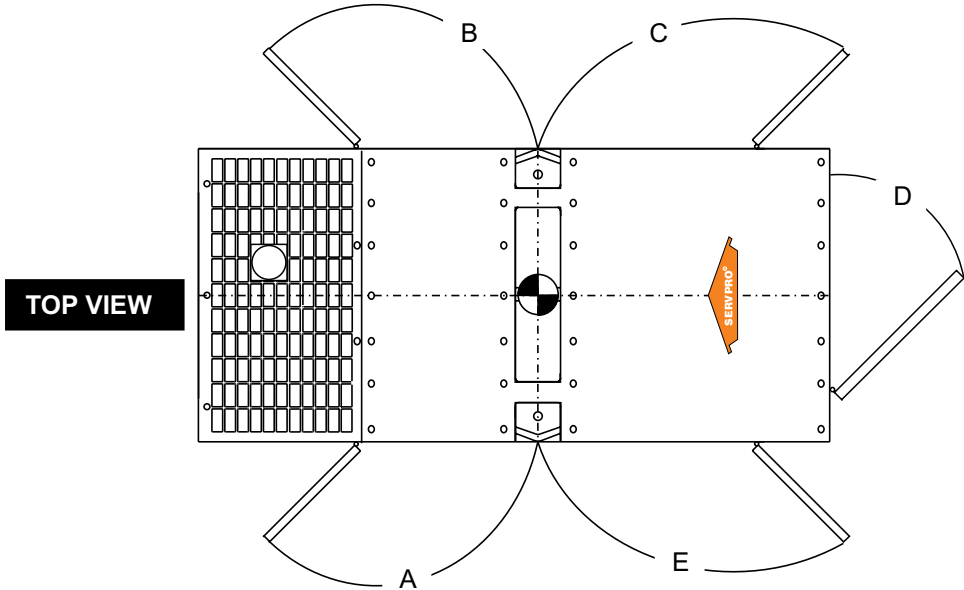

Figure 1. Dimensions

Table 4. Dimensions			
Reference Letter	Dimension in. (mm)	Reference Letter	Dimension in. (mm)
A	21.06 in. (535 mm.)	F	72.83 in. (1,850 mm.)
B	21.06 in. (535 mm.)	G	39.37 in. (1,000 mm.)
C	24.21 in. (615 mm.)	H	29.53 in. (750 mm.)
D	26.38 in. (670 mm.)		
E	25.00 in. (635 mm.)		

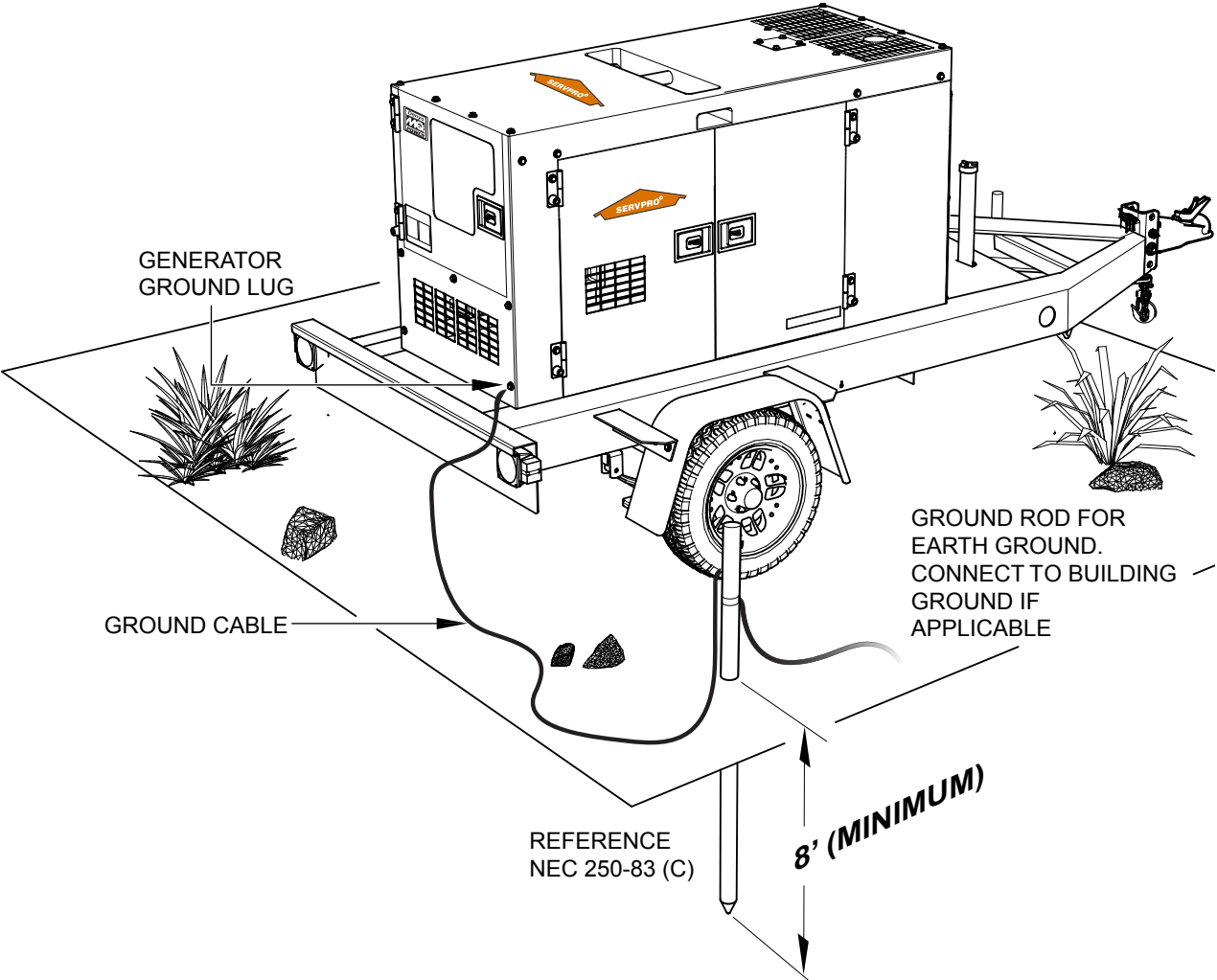

Figure 2. Typical Generator Grounding Application

OUTDOOR INSTALLATION

Install the generator in a area that is free of debris, bystanders, and overhead obstructions. Make sure the generator is on secure level ground so that it cannot slide or shift around. Also install the generator in a manner so that the exhaust will not be discharged in the direction of nearby homes.

The installation site must be relatively free from moisture and dust. All electrical equipment should be protected from excessive moisture. Failure to do will result in deterioration of the insulation and will result in short circuits and grounding.

Foreign materials such as dust, sand, lint and abrasive materials have a tendency to cause excessive wear to engine and alternator parts.

CAUTION

Pay close attention to ventilation when operating the generator inside tunnels and caves. The engine exhaust contains noxious elements. Engine exhaust must be routed to a ventilated area.

INDOOR INSTALLATION

Exhaust gases from diesel engines are extremely poisonous. Whenever an engine is installed indoors the exhaust fumes must be vented to the outside. The engine should be installed at least two feet from any outside wall. Using an exhaust pipe which is too long or too small can cause excessive back pressure which will cause the engine to heat excessively and possibly burn the valves.

MOUNTING

The generator must be mounted on a solid foundation (such as concrete) and set firmly on the foundation to isolate vibration of the generator when it is running. The generator must set at least 6 inches above the floor or grade level (in accordance to NFPA 110, Chapter 5-4.1). **DO NOT** remove the metal skids on the bottom of the generator. They are to resist damage to the bottom of the generator and to maintain alignment.

GENERATOR GROUNDING

To guard against electrical shock and possible damage to the equipment, it is important to provide a good **EARTH** ground (Figure 2).

Article 250 (Grounding) of the National Electrical Code (NEC) provides guide lines for proper grounding and specifies that the cable ground shall be connected to the grounding system of the building as close to the point of cable entry as practical.

NEC articles 250-64(b) and 250-66 set the following grounding requirements:

1. Use one of the following wire types to connect the generator to earth ground.
 - a. Copper - 8 AWG (5.3 mm²) or larger.
 - b. Aluminum - 6 AWG (8.4 mm²) or larger.
2. When grounding the generator (Figure 2) connect the ground cable between the lock washer and the nut on the generator and tighten the nut fully. Connect the other end of the ground cable to earth ground.
3. NEC article 250-52(c) specifies that the earth ground rod should be buried a minimum of 8 ft. into the ground.

NOTICE

When connecting the generator to any buildings electrical system **ALWAYS** consult with a licensed electrician.

GENERAL INFORMATION

GENERATOR

The MQ Power Model DCA20SPXU2 generator (Figure 3) is a high quality portable (requires a trailer for transport) power source for telecom sites, lighting facilities, power tools, submersible pumps and other industrial and construction machinery.

ENGINE PANEL

- Panel Light
- Panel Light Switch
- Fuel Filter Water Level Alarm Lamp
- Auto ON/OFF Engine Controller (MPEC) Switch
- Fuel Guage
- Oil Pressure Gauge
- Water Temperature Guage
- Tachometer Guage
- Charging Ammeter Guage

GENERATOR CONTROL PANEL

The “Generator Control Panel” is provided with the following:

- Frequency Meter (Hz)
- AC Ammeter (Amps)
- AC Voltmeter (Volts)
- Ammeter Change-Over Switch
- Voltage Regulator
- 3-Pole, 90 amp Main Circuit Breaker
- “Control Box” (located behind the Gen. Control Panel)
 - Automatic Voltage Regulator
 - Current Transformer
 - Over-Current Relay
 - Starter Relay

OUTPUT TERMINAL PANEL

The “Output Terminal Panel” is provided with the following:

- Two 120/240V output receptacles (CS-6369), 50A
- Two auxilliary circuit breakers, (for CS-6369), 50A
- Two 120V output receptacles (GFCI), 20A
- Two GFCI circuit breakers, 20A
- Four output terminal lugs (1Ø power)
- Battery Charger (Optional)
- Water Heater (Optional)

OPTIONS

- Battery Charger
- Jacket Water Heater
- Fuel Filter/Water Separator
- Emergency Stop Switch

OPEN DELTA EXCITATION SYSTEM

This generator is equipped with the state of the art “Open-Delta” excitation system. The open delta system consist of an electrically independent winding wound among stationary windings of the AC output section.

There are four connections of the open delta A, B, C and D. During steady state loads, the power from the voltage regulator is supplied from the parallel connections of A to B, A to D, and C to D. These three phases of the voltage input to the voltage regulator are then rectified and are the excitation current for the exciter section.

When a heavy load, such as a motor starting or a short circuit occurs, the automatic voltage regulator (AVR) switches the configuration of the open delta to the series connection of B to C. This has the effect of adding the voltages of each phase to provide higher excitation to the exciter section and thus better voltage response during the application of heavy loads.

The connections of the AVR to the AC output windings are for sensing only. No power is required from these windings. The open-delta design provides virtually unlimited excitation current, offering maximum motor starting capabilities. The excitation does not have a “fixed ceiling” and responds according the demands of the required load.

ENGINE

This generator is powered by a 4 cylinder, water cooled, direct injection, **Izuzu Model BV-4LE2 diesel engine**. This engine is designed to meet every performance requirement for the generator. Reference Table 2 for engine specifications.

In keeping with MQ Power’s policy of constantly improving its products, the specifications quoted herein are subject to change without prior notice.

ELECTRIC GOVERNOR SYSTEM

The electric governor system controls the RPMs of the engine. When the engine demand increases or decreases, the governor system regulates the frequency variation to $\pm 0.25\%$.

EXTENSION CABLES

When electric power is to be provided to various tools or loads at some distance from the generator, extension cords are normally used. Cables should be sized to allow for distance in length and amperage so that the voltage drop between the generator and point of use (load) is held to a minimum. Use the cable selection chart (Table 6) as a guide for selecting proper extension cable size.

GENERATOR MAJOR COMPONENTS

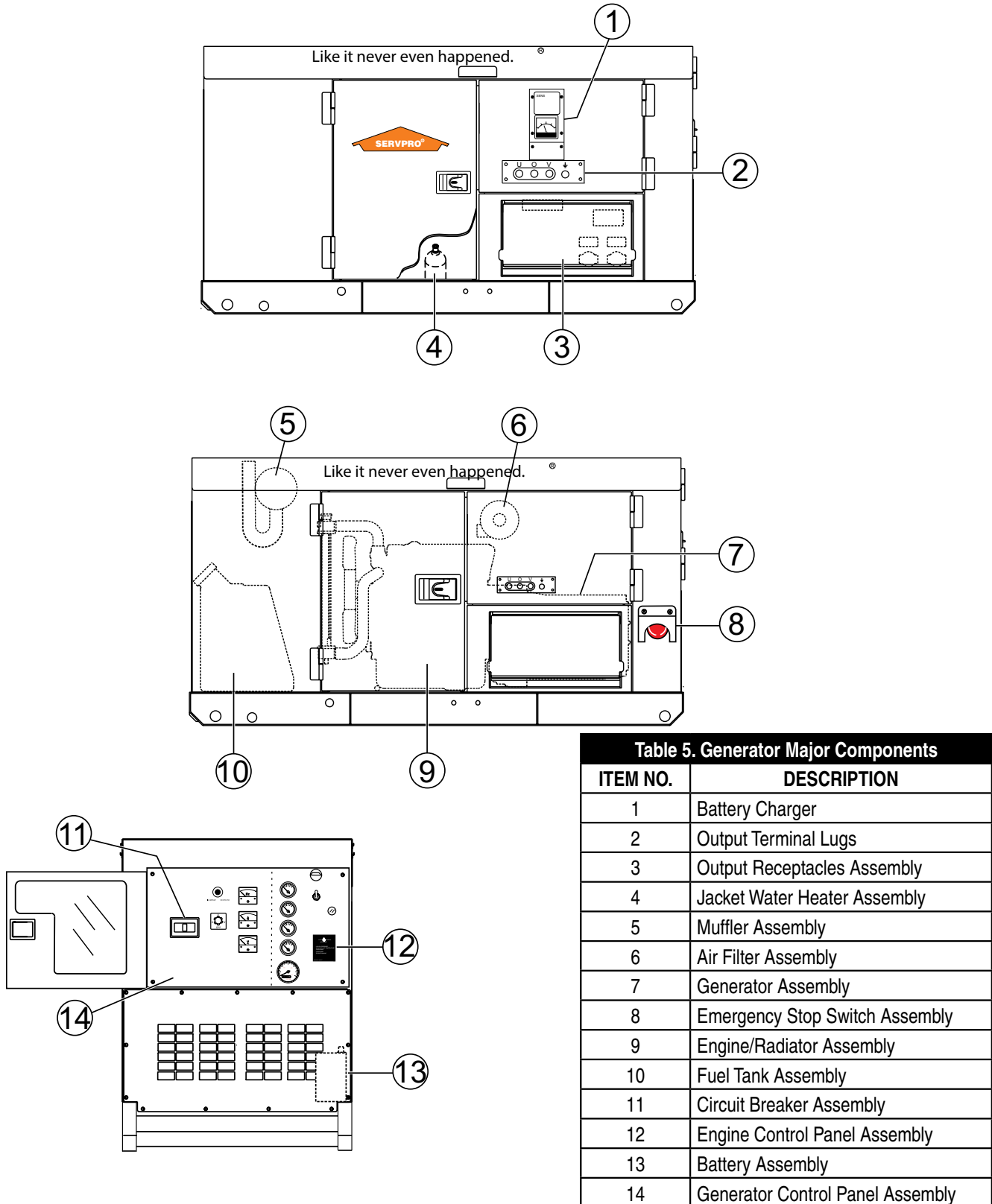

Figure 3. Major Components

TRAILER MAJOR COMPONENTS

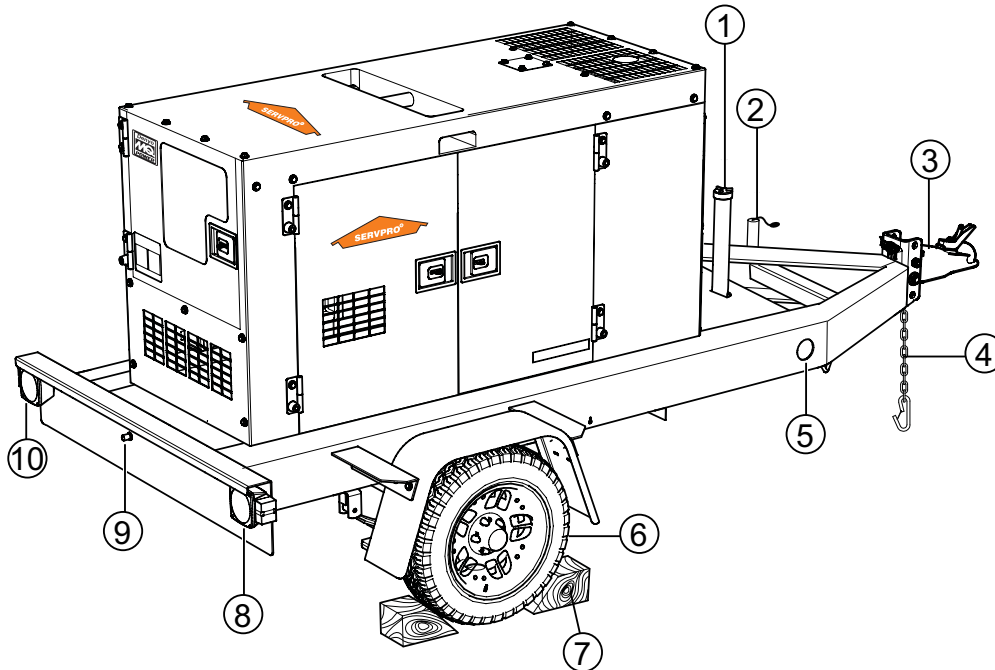

Figure 4. Trailer Components

Figure 4 shows the location of the trailer components. The function of each component is described below:

1. **Fuel Filler Neck/Tank** — This generator may have an external trailer mounted fuel tank. Remove fuel tank cap to add fresh clean No. 2 diesel fuel. External fuel tank capacity is 41 gallons (155 liters).
2. **Tongue Jackstand** — Use this jackstand to support the tongue when attaching the generator to a towing vehicle
3. **Ball Hitch Coupler** — Attach the trailer's 2-inch coupler to the towing vehicle. Use only the specified ball diameter as indicated on your coupler. Use of any other ball diameter will create an extremely dangerous condition which can result in separation of the coupler and ball or ball failure.
4. **Safety Chain** — Always attach safety chains to the towing vehicle. **NEVER** use the trailer with the safety chain unattached. Make sure safety chains are crossed when towing.
5. **Side Reflectors** — There are two amber reflectors located on the side of the trailer. These reflectors provide better visibility in dark conditions.
6. **Tires** — This trailer uses a ST175-80D13 LR-C size tire. Replace with only recommended tire size. **NEVER** use the trailer with bad or worn tires.
7. **Chock Blocks** — Place blocks (not included as part of the generator package) under each trailer wheel to prevent rolling.
8. **Right Brake Light** — Before towing the generator, make sure that this light is operational and is working correctly. **NEVER** use the trailer if this light is inoperative.
9. **License Light** — This light illuminates the license plate. Whenever towing of the generator is required, make sure this light is operational.
10. **Left Brake Light** — Before towing the generator, make sure that this light is operational and is working correctly. **NEVER** use the trailer if this light is inoperative.

GENERATOR CONTROL PANEL

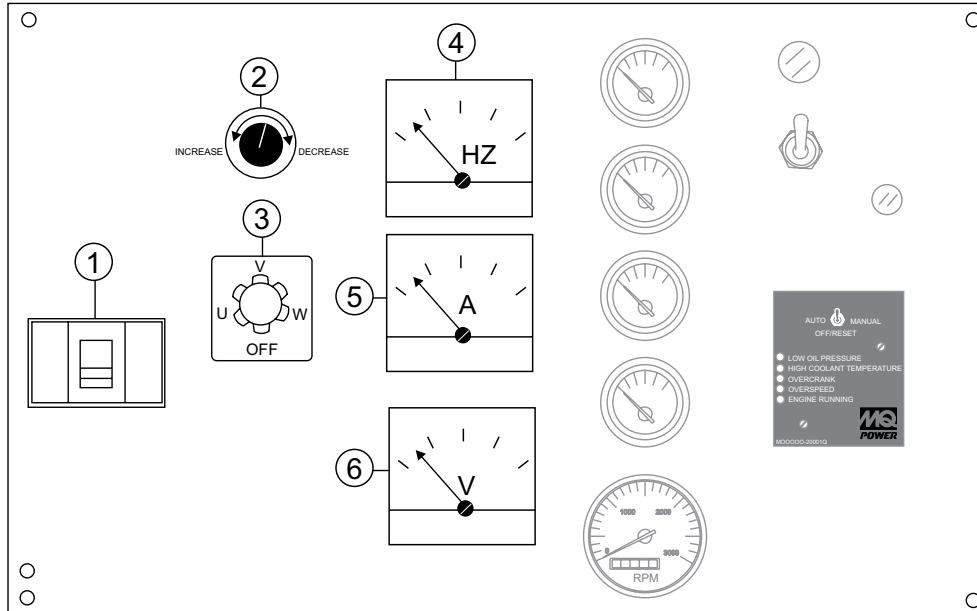

Figure 5. Generator Control Panel

The definitions below describe the controls and functions of the Generator Control Panel (Figure 5).

1. **Main Circuit Breaker**—This three-pole, 90A main breaker is provided to protect the the U,O, and V Output Terminal Lugs from overload.
2. **Voltage Regulator Control** — Allows $\pm 15\%$ manual adjustment of the generator's output voltage.
3. **Ammeter Change-Over Switch** — This switch allows the AC ammeter to indicate the current flowing to the load connected to any phase of the output terminals, or to be switched off. This switch does not effect the generator output in any fashion, it is for current reading only.
4. **Frequency Meter** — Indicates the output frequency in hertz (Hz). Normally 60 Hz.
5. **AC Ammeter** — Indicates the amount of current the load is drawing from the generator per leg selected by the ammeter phase-selector switch.
6. **AC Voltmeter** — Indicates the output voltage present at the U,O, and V Output Terminal Lugs.

Located behind the generator control panel is the Generator Control Box. This box contains some of the necessary electronic components required to make the generator function.

The Control Box is equipped with the following major components:

- Over-Current Relay
- Automatic Voltage Regulator (AVR)
- Starter Relay
- Current Transformer
- Engine Controller

ENGINE CONTROL PANEL

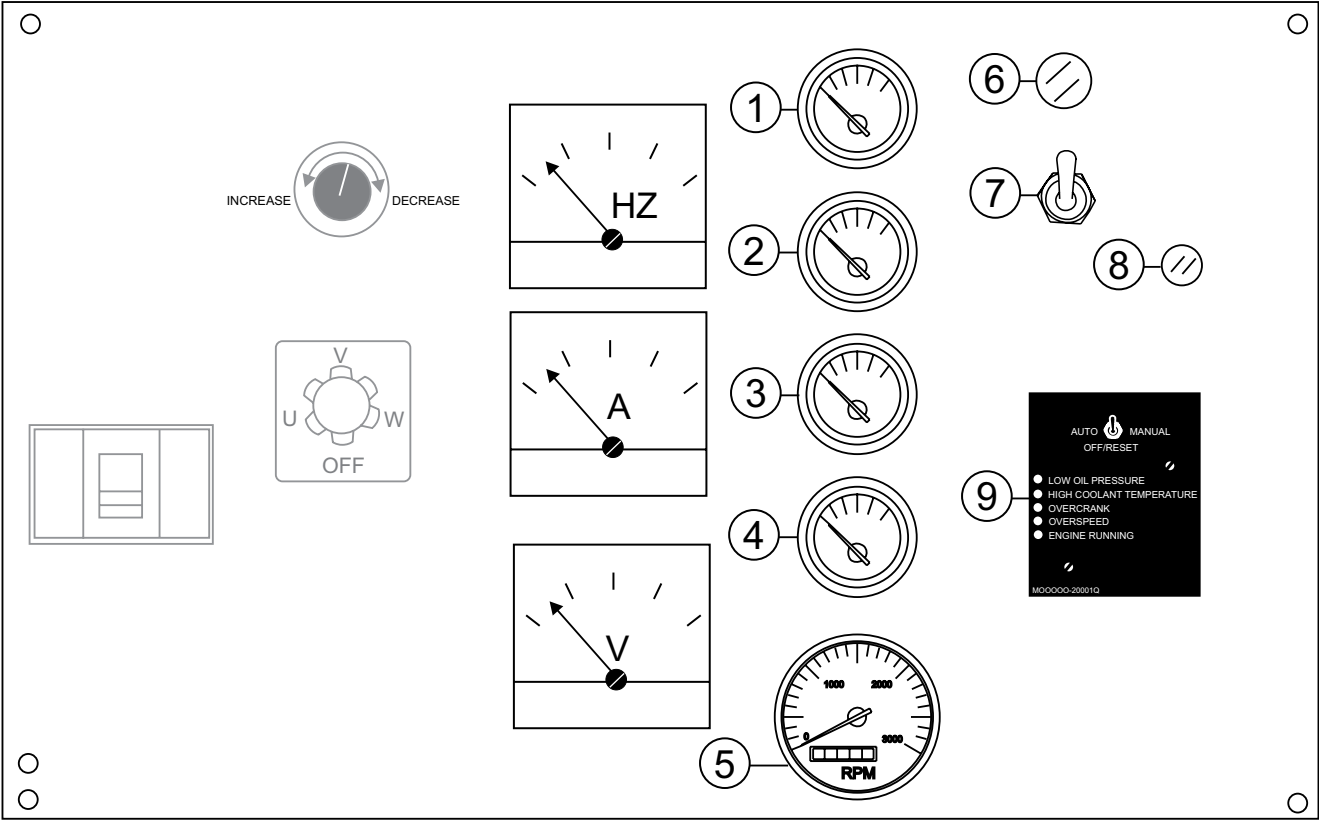

Figure 6. Engine Control Panel

ENGINE CONTROL PANEL

The definitions below describe the controls and functions of the Engine Control Panel (Figure 6).

1. **Oil Pressure Gauge** — During normal operation this gauge should read between 35 to 65 psi. (241~448 kPa). When starting the generator the oil pressure may read a little higher, but after the engine warms up the oil pressure should return to the correct pressure range.
2. **Water Temperature Gauge** — During normal operation this gauge should read between 180°~221°F (82°~105°C)
3. **Charging Ammeter Gauge** — Indicates the current being supplied by the engine's alternator which provides current for generator's control circuits and battery charging system.
4. **Fuel Gauge** — Indicates amount of diesel fuel available.
5. **Tachometer** — Indicates engine speed in RPM's for 60 Hz operation. This meter should indicate 1800 RPM's when the rated load is applied. In addition a built in hour meter will record the number of operational hours that the generator has been in use.
6. **Panel Light** — Normally used in dark areas or at night time. When activated, panel lights will illuminate. When the generator is not in use be sure to turn the panel light switch to the OFF position.
7. **Panel Light Switch** — When activated will turn on control panel light.
8. **Fuel Filter Water Level Alarm Lamp** — This lamp will illuminate when water in the fuel filter has reached an abnormal level.
9. **Auto START/STOP Engine Controller (ECU)** — This controller has a vertical row of status LED's (inset), that when lit, indicate that an engine malfunction (fault) has been detected. When a fault has been detected the engine controller will evaluate the fault and all major faults will shutdown the generator. During cranking cycle, the ECU will attempt to crank the engine for 10 seconds before disengaging.



If the engine does not engage (start) by the third attempt, the engine will be shutdown by the engine controller's Over Crank Protection mode. If the engine engages at a speed (RPM's) that is not safe, the controller will shutdown the engine by initializing the Over Speed Protection mode.

Also the engine controller will shut down the engine in the event of low oil pressure, high coolant temperature, low coolant level, and loss of magnetic pickup. These conditions can be observed by monitoring the LED status indicators on the front of the controller module.

- A. **MPEC Control Switch** — This switch controls the running of the unit. If this switch is set to the OFF/RESET position, the unit will not run. When this switch is set to the manual position, the generator will start immediately.

If the generator is to be connected to a building's AC power source via an automatic transfer switch (isolation), place the switch in the AUTO position. In this position, should an outage occur, the automatic transfer switch (ATS) will start the generator automatically via the generator's auto-start contacts connected to the ATS's start contacts. Please refer to your ATS installation manual for further instructions for the correct installation of the auto-start contacts of the generator to the ATS.

- B. **Low Oil Pressure** — Indicates the engine pressure has fallen below 15 psi (103 kPa). The oil pressure is detected using variable resistive values from the oil pressure sending unit. This is considered a major fault.
- C. **High Coolant Temperature** — Indicates the engine temperature has exceeded 230°F (110°C). The engine temperature is detected using variable resistive values from the temperature sending unit. This is considered a major fault.
- D. **Overcrank Shutdown** — Indicates the unit has attempted to start a pre-programmed number of times, and has failed to start. The number of cycles and duration are programmable. It is pre-set at 3 cycles with a 10 second duration. This is considered a major fault.
- E. **Overspeed Shutdown** — Indicates the engine is running at an unsafe speed. This is considered a major fault.
- F. **Engine Running** — Indicates that engine is running at a safe operating speed.

OUTPUT TERMINAL PANEL FAMILIARIZATION

OUTPUT TERMINAL PANEL

The Output Terminal Panel (Figure 7) shown below is located on the right-hand side (left from control panel) of the generator. Lift the terminal cover to gain access to receptacles and circuit breakers.

NOTICE

Terminal legs "O" and "Ground" are considered bonded grounds.

OUTPUT TERMINAL FAMILIARIZATION

The "Output Terminal Panel" (Figure 7) is provided with the following:

- Two 120/240V output receptacles @ 50 amp
- Two Circuit Breakers @ 50 amps
- Two 120V GFCI receptacles @ 20 amp
- Two GFCI Circuit Breakers @ 20 amps
- Four Output Terminal Lugs (U, O, V, and Ground)

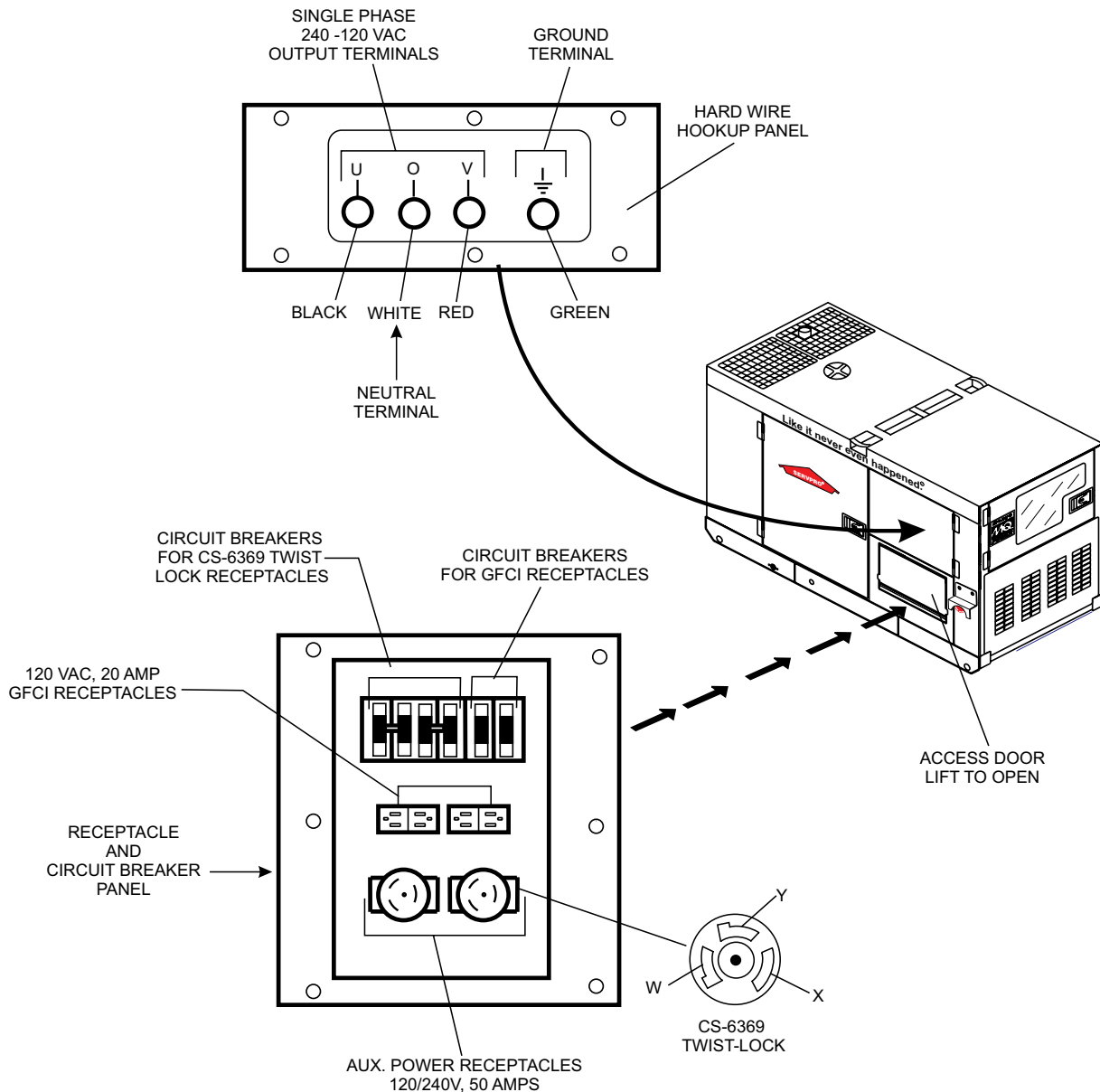

Figure 7. Output Terminal Panel

OUTPUT TERMINAL PANEL FAMILIARIZATION

120 VAC GFCI Receptacles

There are two 120 VAC, 20 amp GFCI (Duplex Nema 5-20R) receptacles provided on the output terminal panel. These receptacles can be accessed in **any voltage selector switch** position. Each receptacle is protected by a 20 amp circuit breaker. These breakers are located directly above the GFCI receptacles. Remember the load output (current) of both GFCI receptacles is dependent on the load requirements of the U, O, and V output terminal lugs.

Pressing the **reset** button resets the GFCI receptacle after being tripped. Pressing the **test button** (See Figure 8) in the center of the receptacle will check the GFCI function. Both receptacles should be tested at least once a month.

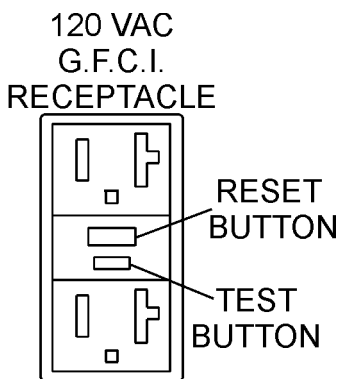

Figure 8. G.F.C.I. Receptacle

Twist Lock Dual Voltage 120/240 VAC Receptacles

There are two 120/240V, 50 amp auxiliary twist-lock (CS-6369) receptacles (Figure 9) provided on the output terminal panel..

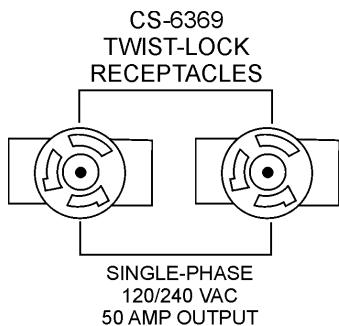

Figure 9. 120/240V Twist-Lock Auxiliary Receptacles

Each auxiliary receptacle is protected by a 50 amp circuit breaker. These breakers are located directly above the GFCI receptacles. Remember the load output (current) on all three receptacles is dependent on the load requirements of the **Output Terminal Lugs**.

Turn the **voltage regulator control knob** (Figure 10) on the control panel to obtain the desired voltage. Turning the knob clockwise will **increase** the voltage, turning the knob counter-clockwise will **decrease** the voltage.

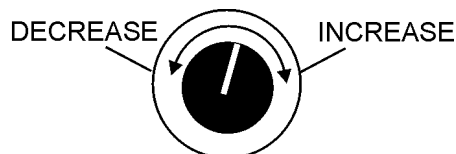

Figure 10. Voltage Regulator Control Knob

Removing the Plastic Face Plate (Hard Wire Hookup Panel)

The **Output Terminal Lugs** are protected by a plastic face plate cover (Figure 11). Un-screw the securing bolts and lift the plastic terminal cover to gain access to the terminal enclosure.

After the load wires have been securely attached to the terminal lugs, reinstall the plastic face plate.

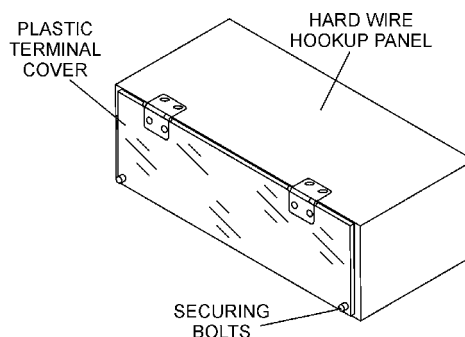

Figure 11. Plastic Face Plate (Output Terminal Lugs)

OUTPUT TERMINAL PANEL FAMILIARIZATION

Connecting Loads

Loads can be connected to the generator by the **Output Terminal Lugs** or the convenience receptacles (Figure 12). Make sure to read the operation manual before attempting to connect a load to the generator.

To protect the output terminals from overload, a 3-pole, 90A **main** circuit breaker is provided. Make sure to switch **ALL** circuit breakers to the **OFF** position prior to starting the engine.

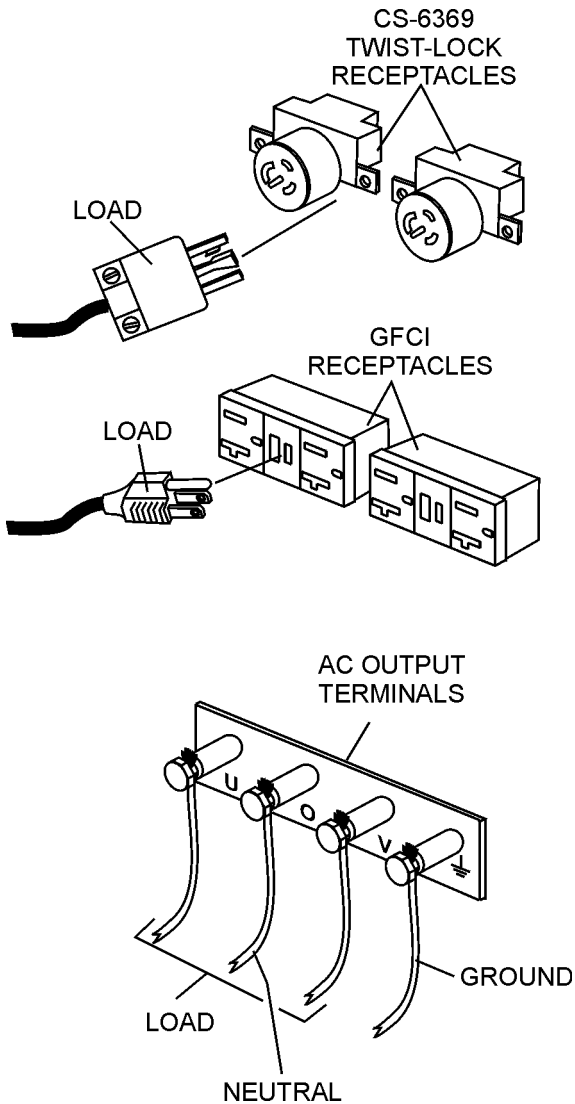

Figure 12. Connecting Loads

Over Current Relay

An **over current relay** (Figure 13) is connected to the main circuit breaker. In the event of an overload, both the circuit breaker and the over current relay may trip. If the circuit breaker can not be reset, the **reset button** on the over current relay must be pressed. The over current relay is located in the control box.

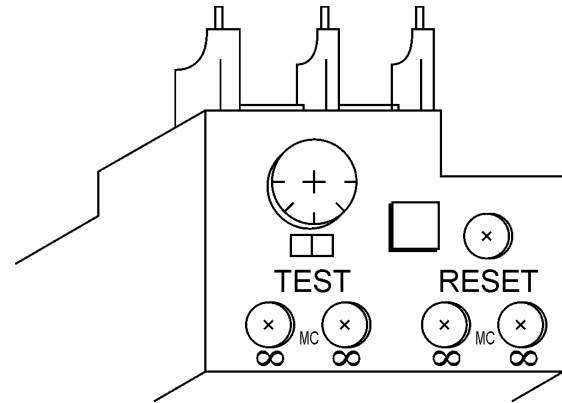

Figure 13. Over Current Relay

NOTICE

When connecting a load to the generator **ALWAYS** make sure the load has an ON/OFF switch. **DO NOT** use the circuit breakers on the generator as a method of turning the load ON and OFF.

LOAD APPLICATION/GENERATOR OUTPUT

SINGLE PHASE LOAD

Always be sure to check the nameplate on the generator and equipment to insure the wattage, amperage, frequency, and voltage requirements are satisfactorily supplied by the generator for operating the equipment.

Generally, the wattage listed on the nameplate of the equipment is its rated output. Equipment may require 130—150% more wattage than the rating on the nameplate, as the wattage is influenced by the efficiency, power factor and starting system of the equipment.

NOTICE

If wattage is not given on the equipment's name plate, approximate wattage may be determined by multiplying nameplate voltage by the nameplate amperage.

$$\text{WATTS} = \text{VOLTAGE} \times \text{AMPERAGE}$$

The power factor of this generator is 0.8. See Table 6 below when connecting loads.

Table 6. Power Factor By Load

Type of Load	Power Factor
Single-phase induction motors	0.4-0.75
Electric heaters, incandescent lamps	1.0
Fluorescent lamps, mercury lamps	0.4-0.9
Electronic devices, communication equipment	1.0
Common power tools	0.8

Table 7. Cable Selection (60 Hz, Single Phase Operation)

Current in Amperes	Load in Watts		Maximum Allowable Cable Length			
	At 100 Volts	At 200 Volts	#10 Wire	#12 Wire	#14 Wire	#16 Wire
2.5	300	600	1000 ft.	600 ft.	375 ft.	250 ft.
5	600	1200	500 ft.	300 ft.	200 ft.	125 ft.
7.5	900	1800	350 ft.	200 ft.	125 ft.	100 ft.
10	1200	2400	250 ft.	150 ft.	100 ft.	
15	1800	3600	150 ft.	100 ft.	65 ft.	
20	2400	4800	125 ft.	75 ft.	50 ft.	

CAUTION: Equipment damage can result from low voltage

NOTICE

Motors and motor-driven equipment draw much greater current for starting than during operation.

An inadequate size connecting cable which cannot carry the required load can cause a voltage drop which can burn out the appliance or tool and overheat the cable. See Table 7

- When connecting a resistance load such as an incandescent lamp or electric heater, a capacity of up to the generating set's rated output (kW) can be used.
- When connecting a fluorescent or mercury lamp, a capacity of up to the generating set's rated output (kW) multiplied by 0.6 can be used.
- When connecting an electric drill or other power tools, pay close attention to the required starting current capacity.

When connecting ordinary power tools, a capacity of up to the generating set's rated output (kW) multiplied by 0.8 can be used.

DANGER

Before connecting this generator to any building's electrical system, a **licensed electrician** must install an **isolation (transfer) switch**. Serious damage to the building's electrical system may occur without this transfer switch.

Generator Amperage

Table 8 shows the **maximum** amps the generator can provide. **DO NOT** exceed the maximum amps as listed.

Table 8. Generator Maximum Amps

Rated Voltage	Maximum Amps
1Ø 120 Volt	83 X 2 amps (4 wire)
1Ø 240 Volt	83 amps (4 wire)

OUTPUT TERMINAL PANEL CONNECTIONS

UOV TERMINAL OUTPUT VOLTAGES

240/120V output voltages can be obtained using the **output terminal lugs**.

The voltage regulator (VR), Figure 15 allows the user to increase or decrease the selected voltage.

1Ø-240 Output Terminal Voltage

1. Connect the load wires to the output terminal lugs as shown in Figure 14.

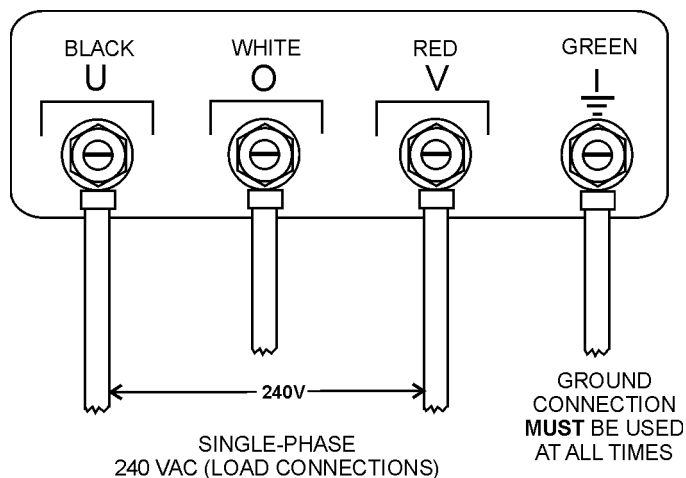

**Figure 14. Output Terminal Lugs
1Ø-240 Volt Connections**

2. Turn the voltage regulator knob (Figure 15) clockwise to increase voltage output, turn counterclockwise to decrease voltage output. Use voltage regulator adjustment knob whenever fine tuning of the output voltage is required.

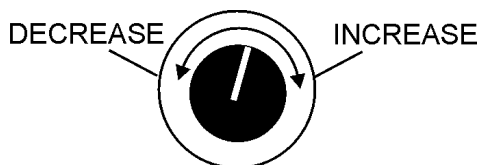
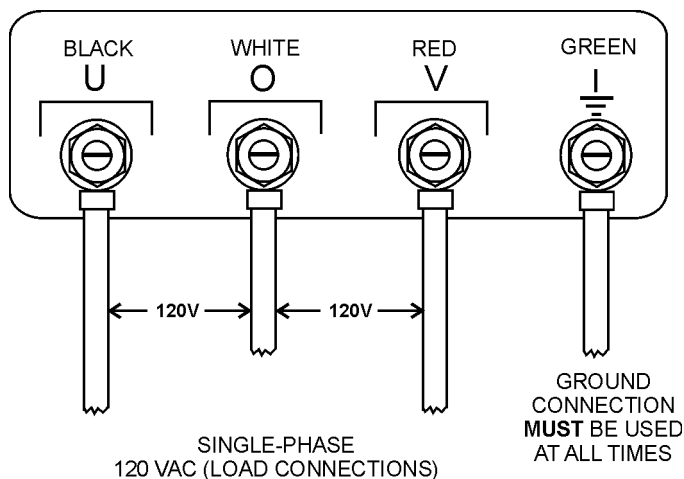

Figure 15. Voltage Regulator Knob

1Ø-120 Output Terminal Voltage

1. Connect the load wires to the output terminal lugs as shown in Figure 16.



**Figure 16. Output Terminal Lugs
1Ø-120 Volt Connections**

2. Turn the voltage regulator knob (Figure 15) clockwise to increase voltage output, turn counterclockwise to decrease voltage output.

NOTICE

ALWAYS make sure that the connections to the UVO terminal lugs are **secure** and **tight**. The possibility of arcing exists, that could cause a fire.

CIRCUIT BREAKERS

To protect the generator from an overload, a 3-pole, 90 amp, main circuit breaker is provided to protect the **U,O and V Output Terminals** from overload. In addition two single-pole, 20 amp **GFCI** circuit breakers are provided to protect the GFCI receptacles from overload. Two 50 amp **load** circuit breakers have also been provided to protect the auxiliary receptacles from overload. Make sure to switch **ALL** circuit breakers to the **OFF** position prior to starting the engine.

LUBRICATION OIL

Fill the engine crankcase with lubricating oil through the filler hole, but **DO NOT** overfill. Make sure the generator is level and verify that the oil level is maintained between the two notches (Figure 17) on the dipstick. See Table 9 for proper selection of engine oil.

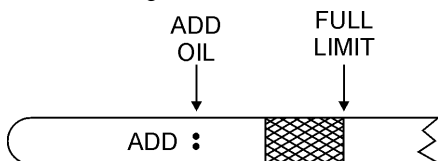

Figure 17. Engine Oil Dipstick

When checking the engine oil, be sure to check if the oil is clean. If the oil is not clean, drain the oil by removing the oil drain plug, and refill with the specified amount of oil as outlined in the **ISUZU Engine Owner's Manual**. Oil should be warm before draining.

Other types of motor oils may be substituted if they meet the following requirements:

- API Service Classification CC/SC
- API Service Classification CC/SD
- API Service Classification CC/SE
- API Service Classification CC/SF

Table 9. Recommended Motor Oil		OIL: SAE	
°F	°C		
122	50		
104	40	10W/40	30
86	30		
68	20		
50	10		
32	0	ARCTIC OIL	5W/30
-14	-10		
-4	-20		
-22	-30		
-40	-40		
		10W/40	15W/30
			10W/30
			10W
			20W/40

FUEL CHECK

! DANGER



Fuel spillage on a **hot** engine can cause a **fire** or **explosion**. If fuel spillage occurs, wipe up the spilled fuel completely to prevent fire hazards. **NEVER** smoke around or near the generator.

Refilling the Fuel System

! CAUTION

ONLY properly trained personnel who have read and understand this section should refill the fuel tank system.

This generator has an internal fuel tank located inside the trailer frame and may also be equipped with an environmental fuel tank (Figure 18). **ALWAYS** fill the fuel tanks with clean fresh **#2 diesel fuel**. **DO NOT** fill the fuel tanks beyond their capacities.

Pay attention to the fuel tank capacity when replenishing fuel. The fuel tank cap must be closed tightly after filling. Handle fuel in a safety container. If the container does not have a spout, use a funnel. Wipe up any spilled fuel immediately.

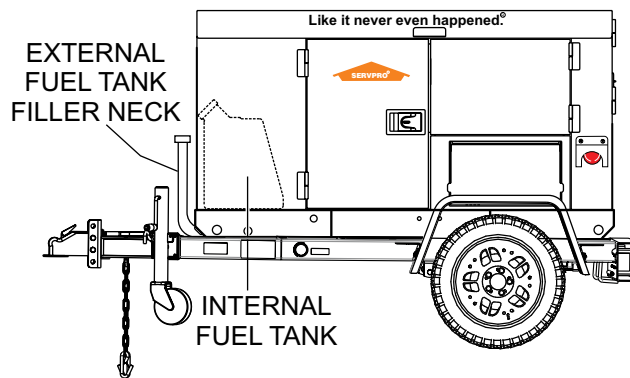

Figure 18. Trailer Fuel Tank

INSPECTION/SETUP

Refueling Procedure:

! WARNING



Diesel fuel and its vapors are dangerous to your health and the surrounding environment. Avoid skin contact and/or inhaling fumes.

1. **Level Tanks** — Make sure fuel cells are level with the ground. Failure to do so will cause fuel to spill from the tank before reaching full capacity (Figure 19).

! CAUTION

ALWAYS place trailer on firm level ground before refueling to prevent spilling and maximize the amount of fuel that can be pumped into the tank.

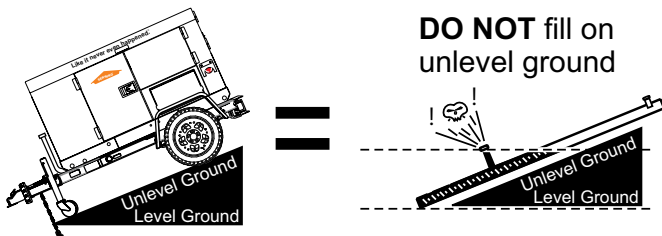

Figure 19. Only Fill on Level Ground

NOTICE

ONLY use #2 diesel fuel when refueling.

2. Remove fuel cap from filler neck and fill fuel tank (Figure 20).
3. **NEVER overfill fuel tank** — It is important to read the fuel gauge when filling trailer fuel tank. **DO NOT** wait for fuel to rise in filler neck (Figure 20).

FUEL GAUGE LOCATED ON CONTROL PANEL

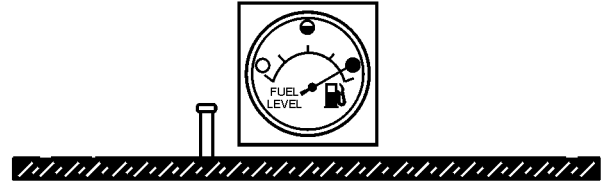

Figure 20. Full Fuel Tank

! CAUTION

DO NOT OVERFILL fuel system. Leave room for fuel expansion. Fuel expands when heated (Figure 21).

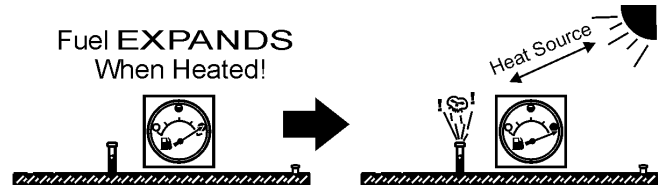

Figure 21. Fuel Expansion

COOLANT (ANTIFREEZE/SUMMER COOLANT/WATER)

ISUZU recommends antifreeze/summer coolant for use in their engines, which can be purchased in concentrate (and mixed with 50% demineralized water) or pre-diluted. See the **ISUZU Engine Owner's Manual** for further details.

! WARNING



If adding coolant/antifreeze mix to the radiator, **DO NOT** remove the radiator cap until the unit has completely cooled. The possibility of **hot!** coolant exists which can cause severe burns.

INSPECTION/SETUP

Day-to-day addition of coolant is done from the recovery tank. When adding coolant to the radiator, **DO NOT** remove the radiator cap until the unit has completely cooled. See Table 10 for engine, radiator, and recovery tank coolant capacities. Make sure the coolant level in the recovery tank is always between the “H” and the “L” markings.

Table 10. Coolant Capacity	
Engine and Radiator	1.74 gal (606 liters)
Reserve Tank	0.26 gal. (1 liter)

Operation in Freezing Weather

When operating in freezing weather, be certain the proper amount of antifreeze (Table 11) has been added.

Table 11. Anti-Freeze Operating Temperatures				
Vol % Anti-Freeze	Freezing Point		Boiling Point	
	°C	°F	°C	°F
50	-37	-34	108	226

NOTICE

When the antifreeze is mixed with water, the antifreeze mixing ratio **must be** less than 50%.

CLEANING THE RADIATOR

The engine may overheat if the radiator fins become overloaded with dust or debris. Periodically clean the radiator fins with compressed air. Cleaning inside the machine is dangerous, so clean only with the engine turned off and the **negative** battery terminal disconnected.

AIR CLEANER

Periodic cleaning/replacement is necessary. Inspect it in accordance with the **ISUZU Engine Owner’s Manual**.

FAN BELT TENSION

A slack fan belt may contribute to overheating, or to insufficient charging of the battery. Inspect the fan belt for

damage and wear and adjust it in accordance with the **ISUZU Engine Owner’s Manual**.

The fan belt tension is proper if the fan belt bends 10 to 15 mm (Figure 22) when depressed with the thumb as shown below.

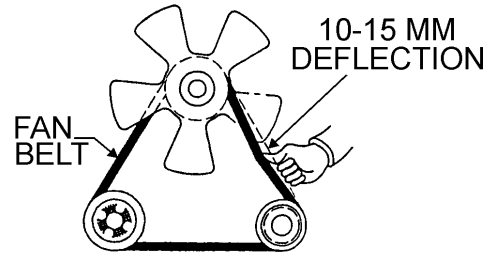

Figure 22. Fan Belt Tension

CAUTION



NEVER place hands near the belts or fan while the generator set is running.

BATTERY

This unit is of negative ground **DO NOT** connect in reverse. Always maintain battery fluid level between the specified marks. Battery life will be shortened, if the fluid level are not properly maintained. Add only distilled water when replenishment is necessary.

DO NOT over fill. Check to see whether the battery cables are loose. Poor contact may result in poor starting or malfunctions. **Always** keep the terminals firmly tightened. Coating the terminals with an approved battery terminal treatment compound. Replace battery with only recommended type battery.

The battery is sufficiently charged if the specific gravity of the battery fluid is 1.28 (at 68° F). If the specific gravity should fall to 1.245 or lower, it indicates that the battery is dead and needs to be recharged or replaced.

Before charging the battery with an external electric source, be sure to disconnect the battery cables.

Battery Cable Installation

ALWAYS be sure the battery cables (Figure 23) are properly connected to the battery terminals as shown below. The **red cable** is connected to the positive terminal of the battery, and the **black cable** is connected to the negative terminal of the battery.

CAUTION

ALWAYS disconnect the negative terminal **FIRST** and reconnect negative terminal **LAST**.

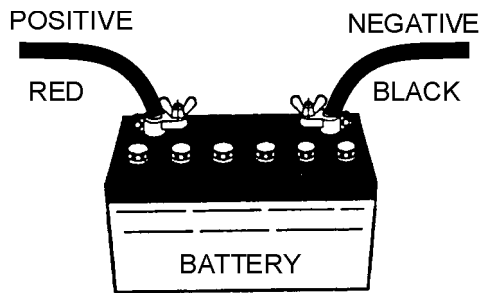

Figure 23. Battery Connections

When connecting battery do the following:

1. **NEVER** connect the battery cables to the battery terminals when the **Control Power Switch** is in the **ON** position. **ALWAYS** make sure that the **Control Power Switch** is in the **OFF** position when connecting the battery.
2. Place a small amount of battery terminal treatment compound around both battery terminals. This will ensure a good connection and will help prevent corrosion around the battery terminals.

NOTICE

If the battery cable is connected incorrectly, electrical damage to the generator will occur. Pay close attention to the polarity of the battery when connecting the battery.

CAUTION

Inadequate battery connections may cause poor starting of the generator, and create other malfunctions.

ALTERNATOR

The polarity of the alternator is negative grounding type. When an inverted circuit connection takes place, the circuit will be in short circuit instantaneously resulting the alternator failure.

DO NOT put water directly on the alternator. Entry of water into the alternator can cause corrosion and damage the alternator.

WIRING

Inspect the entire generator for bad or worn electrical wiring or connections. If any wiring or connections are exposed (insulation missing) replace wiring immediately.

PIPING AND HOSE CONNECTION

Inspect all piping, oil hose, and fuel hose connections for wear and tightness. Tighten all hose clamps and check hoses for leaks.

If any hose (**fuel or oil**) lines are defective replace them immediately.

GENERATOR START-UP PROCEDURE (MANUAL)

BEFORE STARTING

CAUTION

The engine's exhaust contains harmful emissions. **ALWAYS** have adequate ventilation when operating. Direct exhaust away from nearby personnel.

WARNING

NEVER manually start the engine with the **main, GFCI or auxiliary** circuit breakers in the **ON** (closed) position.

- Place the **main, G.F.C.I., and aux.** circuit breakers (Figure 24) in the **OFF** position prior to starting the engine.

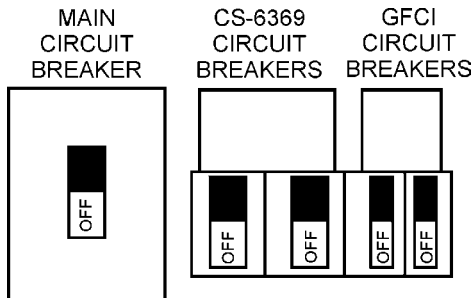

Figure 24. Main, Aux. and GFCI Circuit Breakers (OFF)

- Connect the load to the **receptacles** or the **output terminal lugs** as shown in Figure 12. These load connection points can be found on the output terminal panel and the output terminal panel's hard wire hookup panel.
- Tighten terminal nuts securely to prevent load wires from slipping out.
- Close all engine enclosure doors (Figure 25).

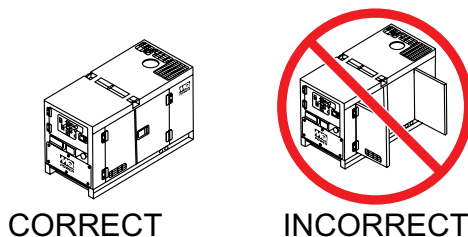

Figure 25. Engine Enclosure Doors

STARTING (MANUAL)

- Place the **MPEC control switch** in the **MANUAL** position to start the engine (Figure 26) position.

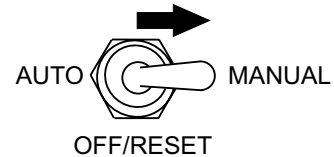

Figure 26. MPEC Control Switch (Manual Position)

- Verify that the **engine running** status LED on the MPEC module (Figure 27) is lit (ON) after the engine has started

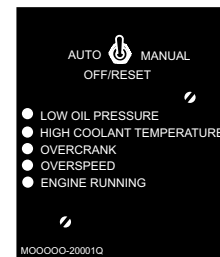

Figure 27. Engine Running (LED ON)

- The generator's frequency meter (Figure 28) should be displaying the 60 cycle output frequency in **HERTZ**.

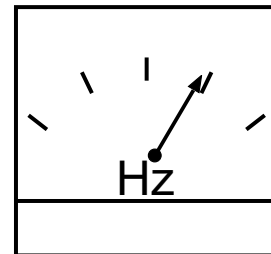

Figure 28. Frequency Meter

- The generator's AC-voltmeter (Figure 29) will display the generator's output in **VOLTS**.

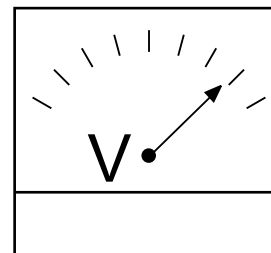

Figure 29. Voltmeter

GENERATOR START-UP PROCEDURE (MANUAL)

- If the voltage is not within the specified tolerance use the voltage adjustment control knob (Figure 30) to increase or decrease the desired voltage.

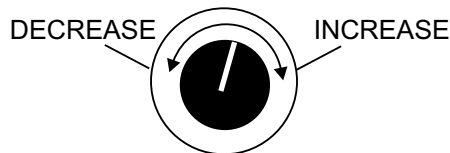

Figure 30. Voltage Adjust Control Knob

- The ammeter (Figure 31) will indicate **zero amps** with no load applied. When a load is applied, the ammeter will indicate the amount of current that the load is drawing from the generator.

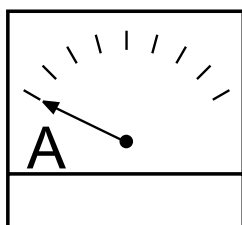

Figure 31. Ammeter (No Load)

- The engine oil pressure gauge (Figure 32) will indicate the oil pressure of the engine. Under normal operating conditions the oil pressure is approximately 35 to 65 psi. (241~448 kPa).

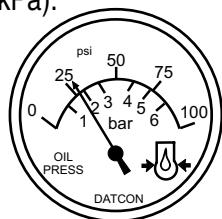

Figure 32. Oil Pressure Gauge

- The **coolant temperature gauge** (Figure 33) will indicate the coolant temperature. Under normal operating conditions the coolant temperature should be between 180°~221°F (82°~105°C) (**Green Zone**).

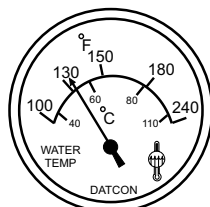

Figure 33. Coolant Temperature Gauge

- The **tachometer gauge** (Figure 34) will indicate the speed of the engine when the generator is operating.

Under normal operating conditions this speed is approximately 1800 RPM's.

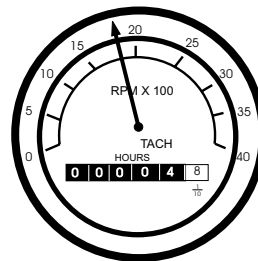

Figure 34. Engine Tachometer Gauge

- Place the **main, G.F.C.I., and aux.** circuit breakers (Figure 35) in the **ON** position.

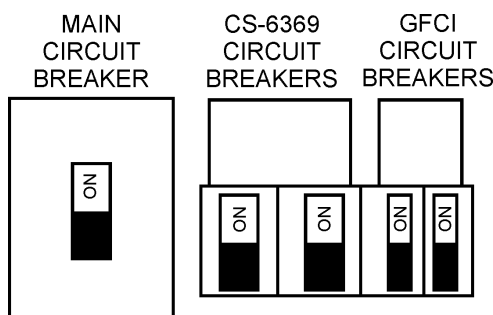

Figure 35. Main, Aux. and GFCI Circuit Breakers (ON)

- Observe the generator's ammeter (Figure 36) and verify it reads the anticipated amount of current with respect to the load. The ammeter will only display a current reading if a load is in use.

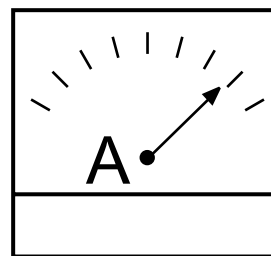



Figure 36. Ammeter (Load)

- The generator will run until manually stopped or an abnormal condition occurs.

GENERATOR SHUT-DOWN PROCEDURES

STARTING (AUTO MODE)

⚠ DANGER



Before connecting this generator to any building's electrical system, a **licensed electrician** must install an **isolation (transfer) switch**. Serious damage to the building's electrical system may occur without this transfer switch.

NOTICE

When connecting the generator to a isolation (transfer) switch, **ALWAYS** have power applied to the generator's internal battery charger. This will ensure that the engine will not fail due to a dead battery

NOTICE

When the MPEC control switch is placed in the **AUTO** mode, the generator will **automatically start** in the event of commercial power falling below a prescribed level by means of a contact closure that is generated automatically by a transfer switch.

In this position (**AUTO**), should an outage occur, the automatic transfer switch (ATS) will start the generator automatically via the generator's auto-start contacts connected to the ATS's start contacts.

Please refer to your ATS installation manual for further instructions for the correct installation of the auto-start contacts of the generator to the ATS.

⚠ WARNING

When running the generator in the **AUTO** mode, remember the generator can start up at any time without warning. **NEVER** attempt to perform any maintenance when the generator is in the auto mode.

1. Place the **MPEC Control Switch** (Figure 37) in the **AUTO** position.



Figure 37. MPEC Control Switch (AUTO)

2. Continue operating the generator as outlined in the Manual Start-up procedure (start at step 2).

GENERATOR SHUT-DOWN PROCEDURES

NORMAL SHUTDOWN PROCEDURE

To shutdown the generator, use the following procedure:

WARNING

NEVER stop the engine suddenly except in an emergency.

1. Place the **main, G.F.C.I., and aux.** circuit breakers (Figure 38) in the **OFF** position.

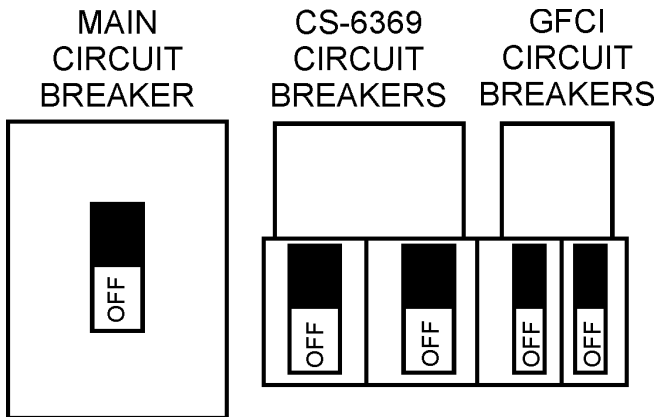

Figure 38. Main, Aux. and GFCI Circuit Breakers (OFF)

2. Let the engine cool by running it at low speed for 3-5 minutes with no load applied.

3. Place the **MPEC Control Switch** (Figure 39) to the **OFF/RESET** position.



Figure 39. MPEC Control Switch (Off/Reset)

4. Verify that **all** the status LEDs on the MPEC display are **OFF** (not lit).
5. Remove all loads from the generator.
6. Inspect entire generator for any damage or loosening of components that may have occurred during operation.

EMERGENCY SHUTDOWN PROCEDURE

1. Place the **main, G.F.C.I., and aux.** circuit breakers (Figure 38) in the **OFF** position.

Table 12. Inspection/Maintenance		10 Hrs DAILY	250 Hrs	500 Hrs	1000 Hrs
Engine	Check Engine Fluid Levels	X			
	Check Air Cleaner	X			
	Check Battery Acid Level	X			
	Check Fan Belt Condition	X			
	Check for Leaks	X			
	Check for Loosening of Parts	X			
	Replace Engine Oil and Filter * 1		X		
	Clean Air Filter		X		
	Check Fuel Filter/Water Separator Bowl	X			
	Clean Unit, Inside and Outside		X		
	Change Fuel Filter			X	
	Clean Radiator and Check Coolant Protection Level*2			X	
	Replace Air Filter Element * 3			X	
	Check all Hoses and Clamps * 4				X
Clean Inside of Fuel Tank				X	
Generator	Measure Insulation Resistance Over 3M ohms		X		
	Check Rotor Rear Support Bearing			X	

*1 Replace engine oil and filter at 100 hours, first time only.

*2 Add "Supplemental Coolant Additives (SCA'S)" to recharge the engine coolant.

*3 Replace primary air filter element when restriction indicator shows a vacuum of 625 mm (25 in. H₂O).

*4 If blowby hose needs to be replaced, ensure that the slope of the blowby hose is at least a 1/2 inch per foot, with no sags or dips that could collect moisture and/or oil.

GENERAL INSPECTION

Prior to each use, the generator should be cleaned and inspected for deficiencies. Check for loose, missing or damaged nuts, bolts or other fasteners. Also check for fuel, oil, and coolant leaks. Use Table 12 as a general maintenance guideline **Engine Side** (Refer to the Engine Instruction Manual)

AIR CLEANER

Every 250 hours: Remove air cleaner element (Figure 40) and clean the heavy duty paper element with light spray of compressed air. Replace the air cleaner as needed.

Air Cleaner with Dust Indicator

This indicator (Figure 40) is attached to the air cleaner. When the air cleaner element is clogged, air intake restriction becomes greater and the dust indicator signal shows **RED** meaning the element needs changing or service. After changing the air element, press the dust indicator button to reset the indicator.

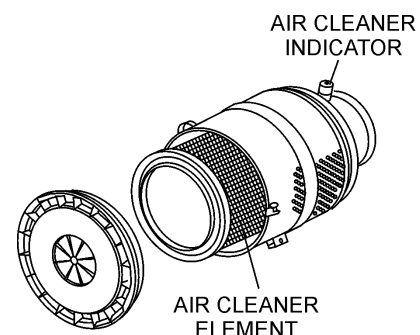

Figure 40. Air Cleaner/Indicator

NOTICE

The air filter should not be changed until the indicator reads "**RED**". Dispose of old air filter. It may not be cleaned or reused.

If the engine is operating in very **dusty** or **dry grass** conditions, a clogged air cleaner will result. This can lead to a loss of power, excessive carbon buildup in the combustion chamber and high fuel consumption. Change air cleaner more **frequently** if these conditions exist.

FUEL ADDITION

Add diesel fuel (the grade may vary according to season and locations).

Removing Water from the Fuel Tank

After prolonged use, water and other impurities accumulate in the bottom of the tank. Occasionally inspect the fuel tank for water contamination and drain the contents if required.

During cold weather, the more empty volume inside the tank, the easier it is for water to condense. This can be reduced by keeping the tank full with diesel fuel.

Cleaning Inside the Fuel Tank

If necessary, drain the fuel inside the fuel tank completely. Using a spray washer (Figure 41) wash out any deposits or debris that have accumulated inside the fuel tank.

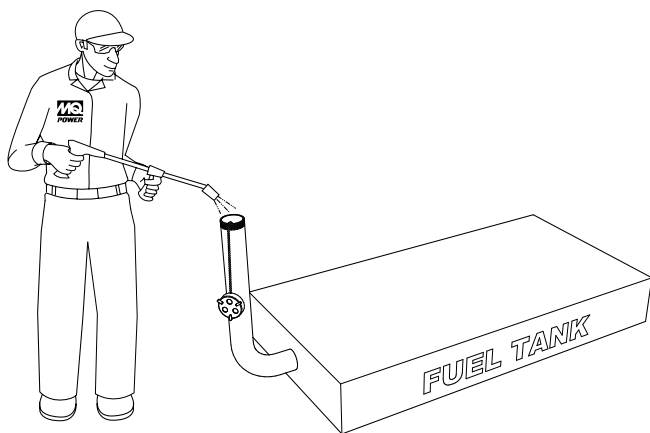

Figure 41. Fuel Tank Cleaning

FUEL TANK INSPECTION

In addition to cleaning the fuel tank, the following components should be inspected for wear:

- **Rubber Suspension** — look for signs of wear or deformity due to contact with oil. Replace the rubber suspension if necessary.
- **Fuel Hoses** — inspect nylon and rubber hoses for signs of wear, deterioration and hardening.
- **Fuel Tank Lining** — inspect the fuel tank lining for signs of excessive amounts of oil or other foreign matter.

Replacing Fuel Filter

- Replace the fuel filter cartridge with new one every 500 hours or so.
- Loosen the drain plug at the lower top of the fuel filter. Drain the fuel in the fuel body together with the mixed water. **DO NOT** spill the fuel during disassembly.
- Vent any air

AIR REMOVAL

If air enters the fuel injection system of a diesel engine, starting becomes impossible. After running out of fuel, or after disassembling the fuel system, bleed the system according to the following procedure. See the **ISUZU Engine Manual** for details.

To restart after running out of fuel, turn the switch to the **ON** position for 15-30 seconds. Try again, if needed.

CHECK OIL LEVEL

Check the crankcase oil level prior to each use, or when the fuel tank is filled. Insufficient oil may cause severe damage to the engine. Make sure the generator is level. The oil level must be between the two notches on the dipstick as shown in Figure 17 .

Replacing Oil Filter

- Remove the old oil filter.
- Apply a film of oil to the gasket on the new oil filter.
- Install the new oil filter.
- After the oil cartridge has been replaced, the engine oil will drop slightly. Run the engine for a while and check for leaks before adding more oil if needed. Clean excessive oil from engine.

FLUSHING OUT RADIATOR AND REPLACING COOLANT

- Open both cocks located at the crankcase side and at the lower part of the radiator and drain coolant. Open the radiator cap while draining. Remove the overflow tank and drain.
- Check hoses for softening and kinks. Check clamps for signs of leakage.
- Tighten both cocks and replace the overflow tank.
- Replace with coolant as recommended by the engine manufacturer.
- Close radiator cap tightly.
- Flush the radiator by running clean tap water through radiator until signs of rust and dirt are removed. **DO NOT** clean radiator core with any objects, such as a screwdriver.

WARNING



Allow engine to **cool** when flushing out radiator. Flushing the radiator while hot could cause serious burns from water or steam.

RADIATOR CLEANING

The radiator (Figure 42) should be sprayed (cleaned) with a high pressure washer when excessive amounts of dirt and debris have accumulated on the cooling fins or tube. When using a high pressure washer, stand at least 5 feet (1.5 meters) away from the radiator to prevent damage to the fins and tube.

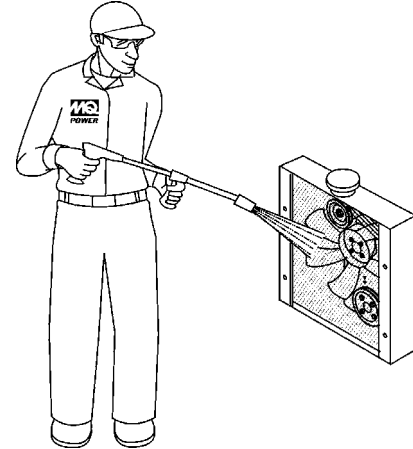

Figure 42. Radiator Cleaning

GENERATOR STORAGE

For long term storage of the generator the following is recommended:

- Drain the fuel tank completely. Treat with a fuel stabilizer if necessary.
- Completely drain the oil from the crankcase and refill if necessary with fresh oil.
- Clean the entire generator, internal and external.
- Cover the generating set and store in a clean, dry place.
- Disconnect the battery.
- Make sure engine coolant is at proper level.
- If generator is mounted on a trailer, jack trailer up and place on blocks so tires do not touch the ground or block and completely remove the tires.

JACKET WATER HEATER AND INTERNAL BATTERY CHARGER 120 VAC INPUT RECEPTACLES

This generator can be optionally equipped with a single 120 VAC, 15 amp input receptacle (Figure 43) located on the output terminal panel.

The purpose of this receptacle is to provide power via commercial power to the **jacket water heater** and **internal battery charger** (Figure 44).

The receptacle will **ONLY** function when commercial power has been supplied to it. To apply commercial power to the receptacle, a power cord of adequate size will be required (See Table 7).

When using the generator in **hot** climates there is no reason to apply power to jacket water heater. However, if the generator will be used in **cold** climates it is always a good idea to apply power to the jacket water heater at all times. To apply power to the jacket water heater simply apply power to the jacket water heater receptacle via commercial power using an power cord of adequate size.

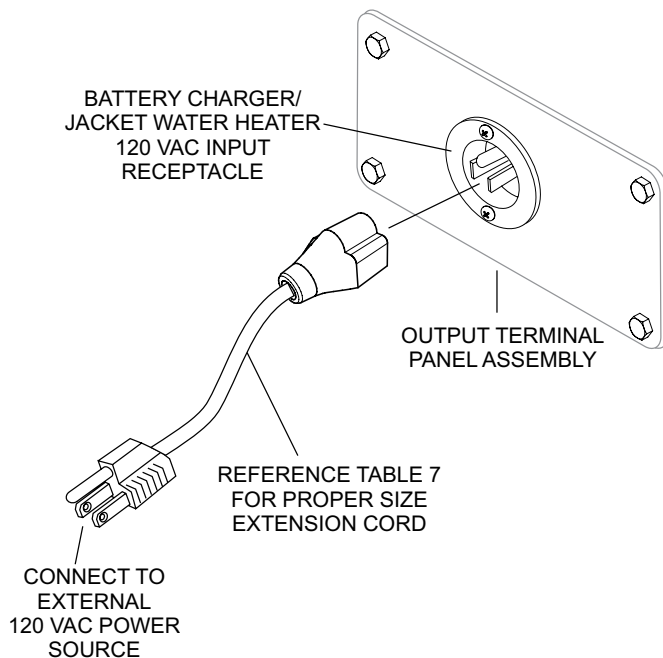

Figure 43. Battery Charger and Jacket Water Heater Power Connections

If the generator will be used daily, the battery should normally not require charging. If the generator will be idle (not used) for long periods of time, apply power to the battery charger receptacle via commercial power using a power cord of adequate size.

NOTICE

To ensure adequate starting capability, always have power applied to the generator's internal battery charger.

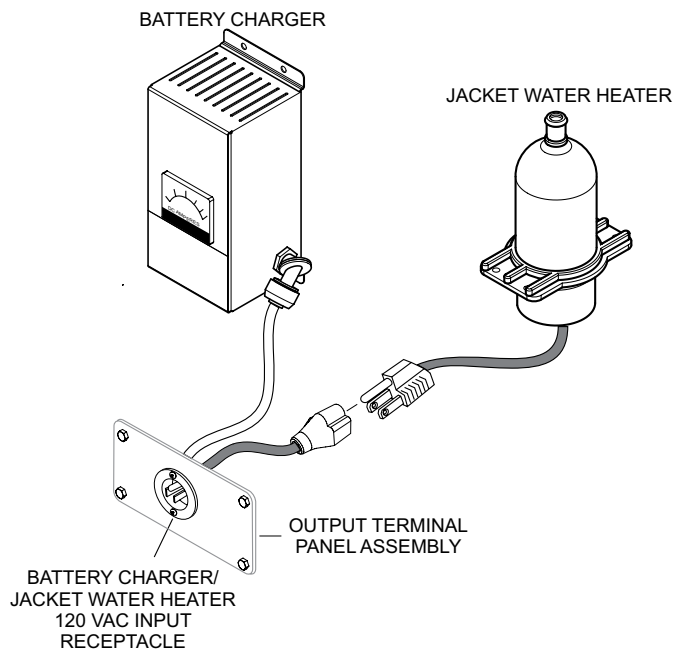

Figure 44. Jacket Water Heater/Battery Charger

TRAILER MAINTENANCE

TRAILER MAINTENANCE

The following trailer maintenance guidelines are intended to assist the operator in preventive maintenance.

Adjustable Channel

Your trailer may be equipped with an adjustable channel (Figure 45) that allows the coupler to be raised or lowered to a desired height. Periodically check the channel bolts for damage or loosening.

NOTICE

When replacing channel mounting hardware (nuts, bolts and washers), **NEVER** substitute substandard hardware. Pay close attention to **bolt length** and **grade**. **ALWAYS** use manufacturer's recommended parts when replacing channel mounting hardware.

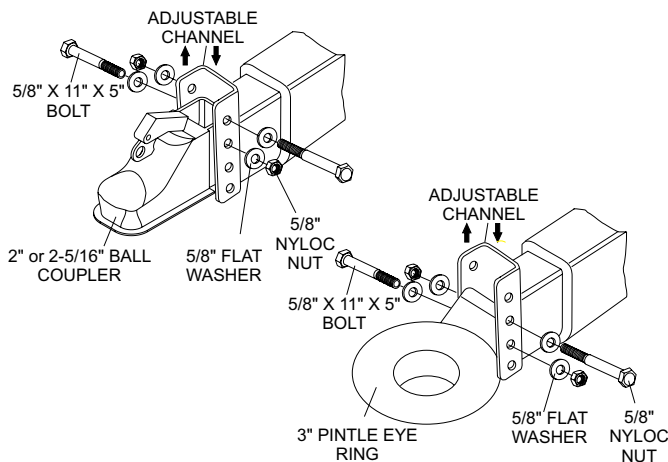

Figure 45. Adjustable Channel

Wheel Bearings

Wheel bearings (Figure 46) must be inspected and lubricated once a year or 12,000 miles to insure safe operation of your trailer.

If trailer wheel bearings are immersed in water, they must be replaced.

DANGER

If trailer wheels are under water for a long period of time, wheel bearings may fail. If this is the case, service wheel bearings immediately.

The possibility exists of the wheels falling off causing equipment damage and severe bodily harm even death!

If the trailer has not been used for an extended amount of time, have the bearings inspected and packed more frequently, at least every six months and prior to use.

Follow the steps below to disassemble the wheel hub and service the wheel bearings. See Figure 46.

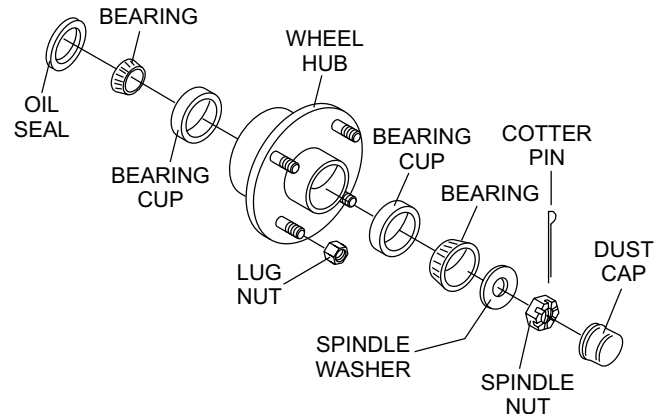

Figure 46. Wheel Hub Components

- After removing the dust cap, cotter pin, spindle nut and spindle washer, remove the hub to inspect the bearings for wear and damage.
- Replace bearings that have flat spots on rollers, broken roller cages, rust or pitting. Always replace bearings and cups in sets. The inner and outer bearings are to be replaced at the same time.
- Replace seals that have nicks, tears or wear.
- Lubricate the bearings with a high quality EP-2 automotive wheel bearing grease.

Wheel Hub Adjustment

Every time the wheel hub is removed and the bearings are reassembled, follow the steps below to check the wheel bearings for free running and adjust.

- Turn the hub slowly, by hand, while tightening the spindle nut until you can no longer turn the hub by hand.
- Loosen the spindle nut just until you are able to turn it (the spindle nut) by hand. Do not turn the hub while the spindle nut is loose.
- Install a new cotter pin through the spindle nut and axle.
- Check the adjustments. Both the hub and the spindle nut should be able to move freely (the spindle nut motion will be limited by the cotter pin).

TRAILER MAINTENANCE

! DANGER

NEVER crawl under the trailer unless it is on firm and level ground and resting on properly placed and secured jackstands.

The possibility exists of the trailer falling thus causing equipment damage and severe bodily harm even death!

! DANGER

When performing trailer inspection and maintenance activities, you must jack up the trailer using jacks and jackstands.

When jacking and using jackstands, place them so as to clear wiring, brake lines, and suspension parts (i.e., springs, torsion bars). Place jacks and jackstands inside of the perimeter strip on the supporting structure to which the axles are attached.

! DANGER

Improper weld repair will lead to early failure of the trailer structure and can cause serious injury or death.

DO NOT repair cracked or broken welds unless you have a certified welder perform the repair. If not, have the welds repaired by your dealer.

! WARNING

If the trailer is involved in an accident, have it inspected immediately by qualified personnel. In addition, the trailer should be inspected annually for signs of wear or deformations.

Leaf Suspension

The leaf suspension springs and associated components (Figure 47) should be visually inspected every 6,000 miles for signs of excessive wear, elongation of bolt holes, and loosening of fasteners. Replace all damaged parts (suspension) immediately

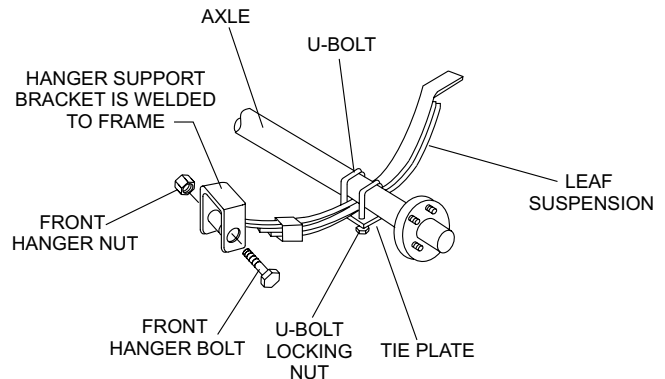

Figure 47. Leaf Suspension Components

! DANGER

Worn or broken suspension parts can cause loss of control, damage to equipment and severe bodily injury, even death!

Check suspension regularly.

TRAILER GUIDELINES

The following guidelines are intended to assist the operator in the operation and handling of a trailer.

Safety precautions should be followed at all times when operating a trailer. Failure to read, understand and follow the safety guidelines could result in injury to yourself and others. Loss of control of the trailer or tow vehicle can result in death or serious injury.

COMMON CAUSES FOR LOSS OF TRAILER

- Driving too fast for the conditions (maximum speed when towing a trailer is 55 mph).
- Overloading the trailer or loading the trailer unevenly.
- Trailer improperly coupled to the hitch.
- No braking on trailer.
- Not maintaining proper tire pressure.
- Not keeping lug nuts tight.
- Not properly maintaining the trailer structure.
- Ensure machine is towed level to tow vehicle.

TRAILER TOWING GUIDELINES

- Recheck the load tiedowns to make sure the load will not shift during towing.
- Before towing, check coupling, safety chain, safety brake, tires, wheels and lights.
- Check the lug nuts or bolts for tightness.
- Check coupler tightness after towing 50 miles.
- Use your mirrors to verify that you have room to change lanes or pull into traffic.
- Use your turn signals well in advance. Allow plenty of stopping space for your trailer and tow vehicle.
- Allow plenty of stopping space for your trailer and tow vehicle.
- **DO NOT** drive so fast that the trailer begins to sway due to speed.
- Allow plenty of room for passing. A rule of thumb is that the passing distance with a trailer is 4 times the passing distance without the trailer.

- Shift your automatic transmission into a lower gear for city driving.
- **ALWAYS** use lower gears for climbing and descending grades.
- **DO NOT** ride the brakes while descending grades, they may get so hot that they stop working. Then you will potentially have a runaway tow vehicle and trailer.
- To conserve fuel, don't use full throttle to climb a hill. Instead, build speed on the approach.
- Slow down for bumps in the road. Take your foot off the brake when crossing the bump.
- **DO NOT** brake while in a curve unless absolutely necessary. Instead, slow down before you enter the curve and power through the curve. This way, the towing vehicle remains in charge.
- **DO NOT** apply the brakes to correct extreme trailer swaying. Continued pulling of the trailer, and even slight acceleration, will provide a stabilizing force.
- Anticipate the trailer "swaying." Swaying is the trailer reaction to the air pressure wave caused by passing trucks and buses. Continued pulling of the trailer provides a stabilizing force to correct swaying. **DO NOT** apply the brakes to correct trailer swaying.
- Use lower gear when driving down steep or long grades. Use the engine and transmission as a brake. Do not ride the brakes, as they can overheat and become ineffective.
- Be aware of your trailer height, especially when approaching roofed areas and around trees.
- Make regular stops, about once each hour. Confirm that:
 - Coupler is secure to the hitch and is locked.
 - Electrical connectors are secure.
 - There is appropriate slack in the safety chains.
 - There is appropriate slack in the breakaway switch pullpin cable.
 - Tires are not visibly low on pressure.

TRAILER GUIDELINES

DRIVING CONDITIONS

When towing a trailer, you will have decreased acceleration, increased stopping distance, and increased turning radius (which means you must make wider turns to keep from hitting curbs, vehicles, and anything else that is on the inside corner). In addition, you will need a longer distance to pass, due to slower acceleration and increased length.

- Be alert for slippery conditions. You are more likely to be affected by slippery road surfaces when driving a tow vehicle with a trailer, than driving a tow vehicle without a trailer.
- Check rearview mirrors frequently to observe the trailer and traffic.
- **NEVER** drive faster than what is safe.

WARNING

Driving too fast for severe road conditions can result in loss of control and cause death or serious injury.

Decrease your speed as road, weather, and lighting conditions deteriorate.

Always check for local trailer tow speed limits in your area.

WARNING

Do not transport people on the trailer. The transport of people puts their lives at risk and may be illegal.

COUPLING TO THE TOW VEHICLE

Follow all of the safety precautions and instructions in this manual to ensure safety of persons, equipment, and satisfactory life of the trailer. Always use an adequate tow vehicle and hitch. If the vehicle or hitch is not properly selected and matched to the Gross Vehicle Weight Rating (GVWR) of your trailer, you can cause an accident that could lead to death or serious injury.

If you already have a tow vehicle, know your vehicle tow rating and make certain the trailer's rated capacity is less than or equal to the tow vehicle's rated towing capacity. If you already have (or plan to buy) a trailer, make certain that the tow rating of the tow vehicle is equal to or greater than that of the trailer.

The trailer VIN tag contains the critical safety information

for the use of your trailer. Again, be sure your hitch and tow vehicle are rated for the Gross Vehicle Weight Rating of your trailer.

WARNING

Proper selection and condition of the coupler and hitch are essential to safely towing your trailer. A loss of coupling may result in death or serious injury.

- Be sure the hitch load rating is equal to or greater than the load rating of the coupler.
- Be sure the hitch size matches the coupler size.
- Observe the hitch for wear, corrosion and cracks before coupling. Replace worn, corroded or cracked hitch components before coupling the trailer to the tow vehicle.
- Be sure the hitch components are tight before coupling the trailer to the tow vehicle.

WARNING

An improperly coupled trailer can result in death or serious injury.

DO NOT move the trailer until:

- The coupler is secured and locked to hitch.
- The safety chains are secured to the tow vehicle.
- The trailer jack(s) are fully retracted.

DO NOT tow the trailer on the road until:

- Tires and wheels are checked.
- The trailer brakes are checked.
- The breakaway switch is connected to the tow vehicle.
- The load is secured to the trailer.
- The trailer lights are connected and checked.

WARNING

Use of a hitch with a load rating less than the load rating of the trailer can result in loss of control and may lead to death or serious injury.

Use of a tow vehicle with a towing capacity less than the load rating of the trailer can result in loss of control, and may lead to death or serious injury.

Be sure your hitch and tow vehicle are rated for the Gross Vehicle Weight Rating of your trailer.

TRAILER GUIDELINES

INOPERABLE BRAKES, LIGHTS OR MIRRORS

Be sure that the brakes and all of the lights on your trailer are functioning properly before towing your trailer. Check the trailer taillights by turning on your tow vehicle headlights. Check the trailer brake lights by having someone step on the tow vehicle brake pedal while you look at trailer lights. Do the same thing to check the turn signal lights. See Trailer Wiring Diagram section in this manual.

Standard mirrors usually do not provide adequate visibility for viewing traffic to the sides and rear of a towed trailer. You must provide mirrors that allow you to safely observe approaching traffic.

⚠ WARNING

Improper electrical connection between the tow vehicle and the trailer will result in inoperable lights and can lead to collision.

Before each tow, check that the tail lights, brake lights and turn signals work.

TRAILER TOWING TIPS

Driving a vehicle with a trailer in tow is vastly different from driving the same vehicle without a trailer in tow. Acceleration, maneuverability and braking are all diminished with a trailer in tow.

It takes longer to get up to speed, you need more room to turn and pass, and more distance to stop when towing a trailer. You will need to spend time adjusting to the different feel and maneuverability of the tow vehicle with a loaded trailer.

Because of the significant differences in all aspects of maneuverability when towing a trailer, the hazards and risks of injury are also much greater than when driving without a trailer. You are responsible for keeping your vehicle and trailer in control, and for all the damage that is caused if you lose control of your vehicle and trailer.

As you did when learning to drive an automobile, find an open area with little or no traffic for your first practice trailering. Of course, before you start towing the trailer, you must follow all of the instructions for inspection, testing, loading and coupling. Also, before you start towing, adjust the mirrors so you can see the trailer as well as the area to the rear of it.

Drive slowly at first, 5 mph or so, and turn the wheel to get the feel of how the tow vehicle and trailer combination responds. Next, make some right and left hand turns. Watch in your side mirrors to see how the trailer follows the tow vehicle. Turning with a trailer attached requires more room.

Stop the rig a few times from speeds no greater than 10 mph. If your trailer is equipped with brakes, try using different combinations of trailer brake and tow vehicle brake. Note the effect that the trailer brakes have when they are the only brakes used. When properly adjusted, the trailer brakes will come on just before the tow vehicle brakes.

It will take practice to learn how to back up a tow vehicle with a trailer attached. Take it slow. Before backing up, get out of the tow vehicle and look behind the trailer to make sure that there are no obstacles.

Some drivers place their hands at the bottom of the steering wheel, and while the tow vehicle is in reverse, “think” of the hands as being on the top of the wheel. When the hands move to the right (counterclockwise, as you would do to turn the tow vehicle to the left when moving forward), the rear of the trailer moves to the right. Conversely, rotating the steering wheel clockwise with your hands at the bottom of the wheel will move the rear of the trailer to the left while backing up.

If you are towing a bumper hitch rig, be careful not to allow the trailer to turn too much because it will hit the rear of the tow vehicle. To straighten the rig, either pull forward or turn the steering wheel in the opposite direction.

TRAILER VIN TAG

Figure A below is a sample of the Vehicle Identification Number (VIN) Tag which is typically located on the left front of the trailer. See Figure B for location.

UFACTURED BY / FABRIQUE PAR:		DATE
R / PNBV	KG (LB)	
R (EACH AXLE) / PNB (CHAQUE ESSIEU)	KG (LB)	TIRES / PNEU
/ JAANT		
I INFL. PRESS. / PRESS. DE GONFL. A FROID	KPA (PSI / LPC <input type="checkbox"/> SINGLE <input type="checkbox"/> DUAL
VEHICLE CONFORMS TO ALL APPLICABLE U.S. FEDERAL MOTOR VEHICLE SAFETY STANDARDS IN EFFECT ON THE DATE OF MANUFACTURE SHOWN ABOVE. VEHICULE CONFORME A TOUTES LES NORMES OUI LIJ SONT APPLICABLES EN VERTU DU REGLEMENT SUR LA SECURITE DES VEHICULES AUTOMOBILES DU CANADA EN VIGUEUR A LA DATE DE SA FABRICATION.		
/ N.I.X.	TYPE / TYPE: TRAILER TRA / REM	FD-306 REV A

Figure A. Vehicle VIN Tag

TRAILER GUIDELINES

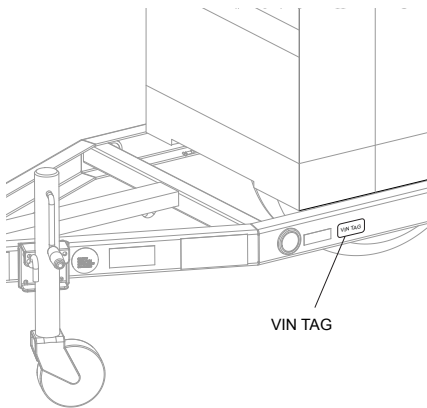

Figure B. VIN Tag Location

The trailer VIN Tag contains the following critical safety information for the use of your trailer.

GAWR: The maximum gross weight that an axle can support. It is the lowest of axle, wheel, or tire rating.

Usually, the tire or wheel rating is lower than the axle rating, and determines GAWR.

GVWR: The maximum allowable gross weight of the trailer and its contents. The gross weight of the trailer includes the weight of the trailer and all of the items within it. GVWR is sometimes referred to as GTWR (Gross Trailer Weight Rating), or MGTW (Maximum Gross Trailer Weight). GVWR, GTWR and MGTW are all the same rating.

The sum total of the GAWR for all trailer axles may be less than the GVWR for the trailer, because some of the trailer load is to be carried by the tow vehicle, rather than by the trailer axle(s). The total weight of the cargo and trailer must not exceed the GVWR, and the load on an axle must not exceed its GAWR.

PSIC: The tire pressure (psi) measured when cold.

VIN: The Vehicle Identification Number.

EMPTY WEIGHT: Some information that comes with the trailer (such as the Manufacturer's Statement of Origin) is not a reliable source for "empty" or "net" weight. The shipping documents list average or standard weights and your trailer may be equipped with options.

To determine the "empty" or "net" weight of your trailer, weigh it on an axle scale. To find the weight of the trailer using an axle scale, you must know the axle weights of your tow vehicle without the trailer coupled. Some of the trailer weight will be transferred from the trailer to the tow vehicle axles, and an axle scale weighs all axles, including the tow vehicle axles.

TOW VEHICLE

The towing hitch attached to your tow vehicle must have a capacity equal to or greater than the load rating of the trailer you intend to tow. The hitch capacity must also be matched to the tow vehicle capacity. Your vehicle dealer can provide and install the proper hitch on your tow vehicle.

SUSPENSION SYSTEM

Sway bars, shock absorbers, heavy duty springs, heavy duty tires and other suspension components may be required to sufficiently tow the trailer and pump.

SIDE VIEW MIRRORS

The size of the trailer that is being towed and your state law regulations determine the size of the mirrors. However, some states prohibit extended mirrors on a tow vehicle, except while a trailer is actually being towed. In this situation, detachable extended mirrors are necessary. Check with your dealer or the appropriate state agency for mirror requirements.

HEAVY DUTY FLASHER

A Heavy Duty Flasher is an electrical component that may be required when your trailer turn signal lights are attached to the tow vehicle flasher circuit.

ELECTRICAL CONNECTOR

An Electrical Connector connects the lights on the trailer to the lights on the towing vehicle.

EMERGENCY FLARES AND TRIANGLE REFLECTORS

It is wise to carry these warning devices even if you are not towing a trailer. It is particularly important to have these when towing a trailer because the hazard flashers of your towing vehicle will not operate for as long a period of time when the battery is running both the trailer lights and tow vehicle lights.

TRAILER GUIDELINES

SAFETY CHAINS

If the coupler connection comes loose, the safety chains can keep the trailer attached to the tow vehicle. With properly rigged safety chains, it is possible to keep the tongue of the trailer from digging into the road pavement, even if the coupler-to-hitch connection comes apart.

JACKSTAND

A device on the trailer that is used to raise and lower the coupler. The jack is sometimes called the “landing gear” or the “tongue jack”.

COUPLER TYPES

Two types of coupler used with the trailer are discussed below.

- Ball Hitch Coupler
- Pintel Eye Coupler

BALL HITCH COUPLER

A ball hitch coupler (Figure C) connects to a ball that is located on or under the rear bumper of tow vehicle. This system of coupling a trailer to a tow vehicle is sometimes referred to as “bumper pull.”

A ball hitch trailer may be fitted with a tongue jack that can raise and lower the coupler. The tongue jack is mounted to the A-frame (front or tongue) part of the trailer. By rotating the jack handle clockwise, the jack will extend and raise the tongue of the trailer.

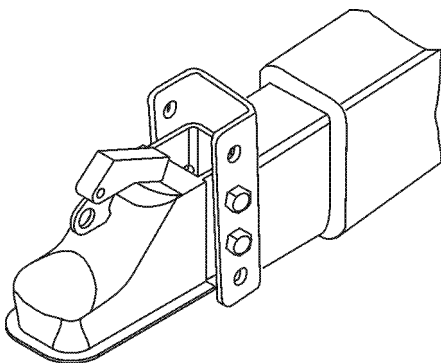

Figure C. Ball Hitch Coupler

Before each tow, coat the ball with a thin layer of automotive bearing grease to reduce wear and ensure proper operation.

Check the locking device that secures the coupler to the ball for proper operation.

If you see or feel evidence of wear, such as flat spots, deformations, pitting or corrosion, on the ball or coupler, immediately have your dealer inspect them to determine the proper action to prevent possible failure of the ball and coupler system. All bent or broken coupler parts must be replaced before towing the trailer.

The coupler handle lever must be able to rotate freely and automatically snap into the latched position. Oil the pivot points, sliding surfaces, and spring ends with SAE 30W motor oil. Keep the ball socket and latch mechanism clean. Dirt or contamination can prevent proper operation of the latching mechanism.

The load rating of the coupler and the necessary ball size are listed on the trailer tongue. You must provide a hitch and ball for your tow vehicle where the load rating of the hitch and ball is equal to or greater than that of your trailer.

Also, the ball size must be the same as the coupler size. If the hitch ball is too small, too large, is underrated, is loose or is worn, the trailer can come loose from the tow vehicle and may cause death or serious injury.

THE TOW VEHICLE, HITCH AND BALL MUST HAVE A RATED TOWING CAPACITY EQUAL TO OR GREATER THAN THE TRAILER Gross Vehicle Weight Rating (GVWR). IT IS ESSENTIAL THAT THE HITCH BALL BE OF THE SAME SIZE AS THE COUPLER.

The ball size and load rating (capacity) are marked on the ball. Hitch capacity is marked on the hitch.

WARNING

Coupler-to-hitch mismatch can result in uncoupling, leading to death or serious injury.

Be sure the **LOAD RATING** of the hitch ball is equal or greater than the load rating of the coupler.

Be sure the **SIZE** of the hitch ball matches the size of the ball coupler.

TRAILER GUIDELINES

WARNING

A worn, cracked or corroded hitch ball can fail while towing and may result in death or serious injury.

Before coupling trailer, inspect the hitch ball for wear, corrosion and cracks.

Replace worn or damaged hitch ball.

WARNING

A loose hitchball nut can result in uncoupling, leading to death or serious injury.

Be sure the hitch ball is tight to the hitch before coupling the trailer.

- Rock the ball to make sure it is tightened to the hitch, and visually check that the hitch ball nut is solid against the lock washer and hitch frame.
- Wipe the inside and outside of the coupler. Clean and visually inspect it for cracks and deformations. Feel the inside of the coupler for worn spots and pits.
- Be sure the coupler is secured tightly to the tongue of the trailer. All coupler fasteners must be visibly solid against the trailer frame.
- The bottom surface of the coupler must be above the top of the hitch ball. Use the tongue jackstand to support the trailer tongue. Wood or concrete blocks may also be used.

Coupling the Trailer to the Tow Vehicle (Ball Coupler)

- Lubricate the hitch ball and the inside of the coupler with a thin layer of automotive bearing grease.
- Slowly back up the tow vehicle so that the hitch ball is near or aligned under the coupler.
- Using the jackstand at the front of trailer (tongue), turn the jackstand crank handle to raise the trailer. If the ball coupler does not line up with the hitch ball, adjust the position of the tow vehicle.
- Open the coupler locking mechanism. Ball couplers have a locking mechanism with an internal moving piece and an outside handle. In the open position, the coupler is able to drop fully onto the hitch ball.

- Lower the trailer (Figure D) until the coupler fully engages the hitch ball.

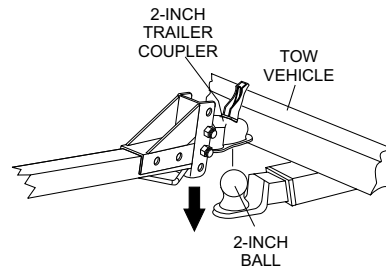

Figure D. Ball Hitch Coupling Mechanism

- Engage the coupler locking mechanism. In the engaged position, the locking mechanism securely holds the coupler to the hitch ball.
- Insert a pin or lock through the hole in the locking mechanism.
- Be sure the coupler is all the way on the hitch ball and the locking mechanism is engaged. A properly engaged locking mechanism will allow the coupler to raise the rear of the tow vehicle. Using the trailer jackstand, verify that you can raise the rear of the tow vehicle by 1 inch after the coupler is locked to the hitch.
- Lower the trailer so that its entire tongue weight is held by the hitch.
- Raise the jackstand to a height where it will not interfere with the road.

NOTICE

Overloading can damage the tongue jack. **DO NOT** use the tongue jack to raise the tow vehicle more than one inch.

If the coupler cannot be secured to the hitch ball, do not tow the trailer. Call your dealer for assistance. Lower the trailer so that its entire tongue weight is held by the hitch and continue retracting the jack to its fully retracted position.

TRAILER GUIDELINES

Attaching Safety Chain

Visually inspect the safety chains and hooks for wear or damage. Replace worn or damaged safety chains and hooks before towing.

Attach the safety chains so that they:

- Cross underneath the coupler. See Figure E.

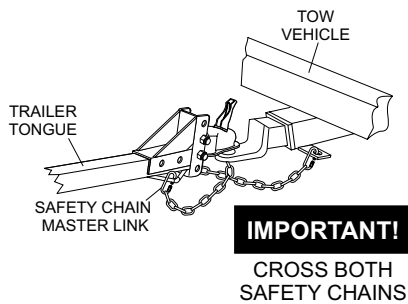

Figure E. Attaching Safety Chain (Ball Hitch)

- Loop around a frame member of the tow vehicle or holes provided in the hitch system (DO NOT attach them to an interchangeable part of the hitch assembly).
- Have enough slack to permit tight turns, but not be close to the road surface, so if the trailer uncouples, the safety chains can hold the tongue up above the road

WARNING

Improper rigging of the safety chains can result in loss of control of the trailer and tow vehicle, leading to death or serious injury, if the trailer uncouples from the tow vehicle.

- Fasten chains to frame of tow vehicle. DO NOT fasten chains to any part of the hitch unless the hitch has holes or loops specifically for that purpose.
- Cross chains underneath hitch and coupler with enough slack to permit turning and to hold tongue up, if the trailer comes loose.

Connecting Trailer Lights

Connect the trailer lights to the tow vehicle's electrical system using the electric connectors at the front of the trailer (tongue). Refer to the wiring diagram shown in the trailer wiring diagram section of this manual. Before towing the trailer check for the following:

- Running lights (turn on tow vehicle headlights).
- Brake Lights (step on tow vehicle brake pedal).

- Backup Lights (place tow vehicle gear shift in reverse).
- Turn Signals (activate tow vehicle directional signal lever).

WARNING

Improper electrical connection between the tow vehicle and the trailer will result in inoperable lights and electric brakes, and can lead to collision.

Before each tow:

- Check that the taillights, brake lights and turn signals work.
- Check that the electric brakes work by operating the brake controller inside the tow vehicle.

Uncoupling the Ball Hitch

Follow these steps to uncouple ball hitch from tow vehicle:

- Block trailer tires to prevent the trailer from rolling, before jacking the trailer up.
- Disconnect the electrical connector.
- Disconnect the breakaway brake switch cable. Promptly replace the pullpin in the switchbox.
- Before extending jackstand, make certain the ground surface below the jackstand foot will support the tongue load.
- Rotate the jackstand handle (or crank) clockwise. This will slowly extend the jack and transfer the weight of the trailer tongue to the jack.

TRAILER GUIDELINES

PINTLE HITCH COUPLER

A pintle eye coupler (Figure F) connects to a pintle-hook hitch that is located on or under the rear bumper of the tow vehicle. This system of coupling a trailer to a tow vehicle is sometimes referred to as a “lunette eye, tow ring or G.I. hitch.”

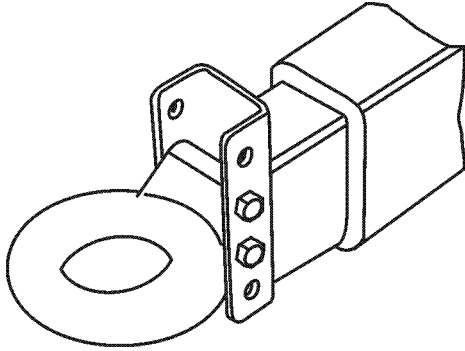

Figure F. Pintle Hitch Coupler

A pintle hitch trailer may be fitted with a tongue jackstand that can raise and lower the coupler. The tongue jack is mounted to the A-frame (front or tongue) part of the trailer. By rotating the jack handle clockwise, the jack will extend and raise the tongue of the trailer.

The load rating of the coupler and the necessary pintle hitch size are listed on the trailer tongue. You must provide a pintle hitch and pintle coupler for your tow vehicle, where the load rating of the pintle hitch and pintle coupler is equal to or greater than that of your trailer.

Also, the pintle hitch size must be the same as the pintle coupler size. If the hitch is too small, too large, underrated, loose or worn, the trailer can come loose from the tow vehicle, and may cause death or serious injury.

Pintle Coupler and Pintle Hook

Before each tow, check the locking device that secures the coupler to the pintle hook assembly.

The pintle hook lever must be able to operate freely and automatically snap into place into the latched position. Lightly oil the pivot points and sliding surfaces with SAE30W motor oil to prevent rust and help ensure proper operation of the latching mechanism.

If you see or feel evidence of wear, such as flat spots, deformations, pitting or corrosion, on the pintle hook or coupler, immediately have your dealer inspect them to determine the proper action to prevent possible failure of the ball and coupler system. All bent or broken coupler parts must be replaced before towing the trailer.

THE TOW VEHICLE, PINTLE HITCH AND PINTLE COUPLER MUST HAVE A RATED TOWING CAPACITY EQUAL TO OR GREATER THAN THE TRAILER Gross Vehicle Weight Rating (GVWR).

IT IS ESSENTIAL THAT THE PINTLE HITCH BE OF THE SAME SIZE AS THE PINTLE COUPLER.

The coupler size and load rating (capacity) are marked on the coupler. Hitch capacity is marked on the hitch.

WARNING

Coupler-to-hitch mismatch can result in uncoupling, leading to death or serious injury.

Be sure the **LOAD RATING** of the pintle hitch hook is equal or greater than the load rating of the pintle eye coupler.

Be sure the **SIZE** of the pintle hitch hook matches the size of the pintle eye coupler.

WARNING

A worn, cracked or corroded pintle hitch hook can fail while towing, and may result in death or serious injury.

Before coupling trailer, inspect the pintle hitch hook for wear, corrosion and cracks.

Replace worn or damaged pintle hitch hook.

- Rock the pintle eye coupler to make sure it is secured tightly to the hitch.
- Wipe the inside and outside of the pintle coupler. Clean and inspect it visually for cracks and deformations. Feel the inside of the coupler for worn spots and pits.
- Be sure the coupler is secured tightly to the tongue of the trailer. All coupler fasteners must be visibly solid against the trailer frame.

TRAILER GUIDELINES

- Raise the bottom surface of the coupler to be above the top of the pintle hitch hook. Use the tongue jackstand to support the trailer tongue. Wood or concrete blocks may also be used.

WARNING

A defective pintle hitch not properly fastened can result in uncoupling, leading to death or serious injury.

Be sure the pintle hook is securely tightened to the tow vehicle before coupling the trailer.

Coupling Trailer to Tow Vehicle (Pintle Coupler)

- Slowly back up the tow vehicle so that the pintle hitch hook is near or aligned under the pintle eye ring coupler.
- Using the jackstand at the front of trailer (tongue), turn the jackstand crank handle to raise the trailer. If the pintle eye coupler does not line up with the pintle hitch hook, adjust the position of the tow vehicle.
- OPEN the pintle hook locking mechanism (Figure G). Place the hook inside the eye coupler. CLOSE the pintle hook mechanism.

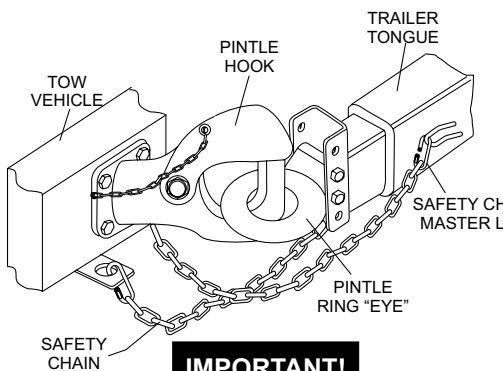

IMPORTANT!

CROSS BOTH

Figure G. Attaching Safety Chain (Pintle Hitch)

- Insert a pin or lock through the hole in the locking mechanism.
- Be sure the pintle hook is inserted completely through the eye ring and the locking mechanism is engaged. A properly engaged locking mechanism will allow the coupler to raise the rear of the tow vehicle. Using the trailer jack, test to see that you can raise the rear of the tow vehicle by 1-inch after the coupler is locked to the hitch.

- Lower the trailer so that its entire tongue weight is held by the hitch.
- Raise the jackstand to a height where it will not interfere with the road.

TIRE SAFETY

Unsafe Tires, Lug Nuts or Wheels

Trailer tires and wheels are more likely to fail than car tires and wheels because they carry a heavier load. Therefore, it is essential to inspect the trailer tires before each tow.

If a tire has a bald spot, bulge, cuts, is showing any cords, or is cracked, replace the tire before towing. If a tire has uneven tread wear, take the trailer to a dealer service center for diagnosis.

Uneven tread wear can be caused by tire imbalance, axle misalignment or incorrect inflation.

Tires with too little tread will not provide adequate tracking on wet roadways and can result in loss of control, leading to death or serious injury.

Improper tire pressure causes an unstable trailer and can result in a tire blowout and loss of control. Therefore, before each tow you must also check the tire pressure. Tire pressure must be checked when tires are cold.

Allow 3 hours cool-down after driving as much as 1 mile at 40 mph before checking tire pressure. Trailer tires will be inflated to higher pressures than passenger vehicle tires.

Since trailer wheels and lug nuts (or bolts) are subjected to greater side loads than automobile wheels, they are more prone to loosen. Before each tow, check to make sure they are tight.

The proper tightness (torque) for lug nuts is listed in the lug nut tightening section of this manual. Use a torque wrench to tighten the lug nuts. If you do not have a torque

TRAILER GUIDELINES

wrench, use a lug wrench (from your tow vehicle) and tighten the nuts as much as you can. Then have a service garage or trailer dealer tighten the lug nuts to the proper torque.

⚠ WARNING

Metal creep between the wheel rim and lug nuts will cause rim to loosen and could result in a wheel coming off, leading to death or serious injury.

Tighten lug nuts before each tow.

Lug nuts are also prone to loosen after first being assembled. When driving a new trailer (or after wheels have been remounted), check to make sure they are tight after the first 10, 25 and 50 miles of driving and before each tow thereafter.

Failure to perform this check can result in a wheel parting from the trailer and a crash, leading to death or serious injury.

⚠ WARNING

Lug nuts are prone to loosen after initial installation, which can lead to death or serious injury.

Check lug nuts for tightness on a new trailer or when wheel(s) have been remounted after the first 10, 25 and 50 miles of driving.

⚠ WARNING

Improper lug nut torque can cause a wheel parting from the trailer, leading to death or serious injury.

Be sure lug nuts are tight before each tow.

⚠ WARNING

Improper tire pressure can result in a blowout and loss of control, which can lead to death or serious injury.

Be sure tires are inflated to pressure indicated on side wall before towing trailer.

Determining Load Limit of Trailer

Determining the load limits of a trailer includes more than understanding the load limits of the tires alone. On all trailers there is a Federal certification/VIN label that is located on the forward half of the left (road) side of the unit.

This certification/VIN label will indicate the trailer's Gross Vehicle Weight Rating (GVWR). This is the most weight the fully loaded trailer can weigh. It will also provide the Gross Axle Weight Rating (GAWR). This is the most a the axle can weigh.

There is a vehicle placard (Figure H) located in the same location as the certification label described above. This placard provides tire and loading information. In addition, this placard will show a statement regarding maximum cargo capacity.

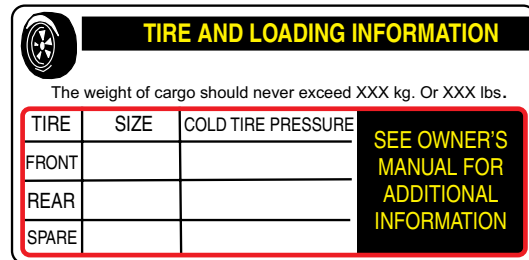

Figure H. Trailer Tire Placard

If additional work items (hoses, tools, clamps etc.) are going to be added to the trailer, be sure they are distributed evenly to prevent overloading front to back and side to side. Heavy items should be placed low and as close to the axle positions as reasonable. Too many items on one side may overload a tire.

Excessive loads and/or underinflation cause tire overloading and, as a result, abnormal tire flexing occurs. This situation can generate an excessive amount of heat within the tire. Excessive heat may lead to tire failure. It is the air pressure that enables a tire to support the load, so proper inflation is critical. The proper air pressure may be found on the certification/VIN label and/or on the Tire and Loading Information placard. This value should never exceed the maximum cold inflation pressure stamped on the tire.

Perform the following steps to determine the load limit of your trailer.

Step 1.

Locate the statement, "The weight of cargo should never exceed XXX kg or XXX lbs.," on your vehicle's Tire and Loading Information placard (Figure I). This value equals the available amount of equipment load capacity.

TRAILER GUIDELINES

Step 2.

Determine the weight of the equipment being loaded on the tow vehicle. That weight may not safely exceed the available equipment load capacity. The trailer's Tire Information Placard is attached adjacent to or near the trailer's VIN (Certification) label at the left front of the trailer (See Figure I).

Determining Load Limit of Tow Vehicle

Step 1.

Locate the statement, "The combined weight of occupants and cargo should never exceed XXX lbs.," on your vehicle's placard.

Step 2.

Determine the combined weight of the driver and passengers who will be riding in your vehicle.

Step 3.

Subtract the combined weight of the driver and passengers from XXX kilograms or XXX pounds.

Step 4.

The resulting figure equals the available amount of cargo and luggage capacity. For example, if the "XXX" amount equals 1400 lbs. and there will be five 150 lb. passengers in your vehicle, the amount of available cargo and luggage capacity is 650 lbs. ($1400 - 750 (5 \times 150) = 650$ lbs.).

Step 5.

Determine the combined weight of luggage and cargo being loaded on the vehicle. That weight may not safely exceed the available cargo and luggage capacity calculated in Step 4.

If your vehicle will be towing a trailer, load from your trailer will be transferred to your vehicle. Consult the tow vehicle's manual to determine how this weight transfer reduces the available cargo and luggage capacity of your vehicle.

Studies of tire safety show that maintaining proper tire pressure, observing tire and vehicle load limits (not carrying more weight in your vehicle than your tires or vehicle can safely handle), avoiding road hazards and inspecting tires for cuts, slashes and other irregularities are the most important things you can do to avoid tire failure, such as tread separation or blowout and flat tires. These actions,

along with other care and maintenance activities, can also:

- Improve vehicle handling.
- Help protect you and others from avoidable breakdowns and accidents.
- Improve fuel economy.
- Increase the tire life.

Use the information contained in this section to make tire safety a regular part of your vehicle maintenance routine. Recognize that the time you spend is minimal compared with the inconvenience and safety consequences of a flat tire or other tire failure.

TIRE FUNDAMENTALS

Federal law requires tire manufacturers to place standardized information on the sidewall of all tires (Figure I). This information identifies and describes the fundamental characteristics of the tire and also provides a tire identification number for safety standard certification and in case of a recall.

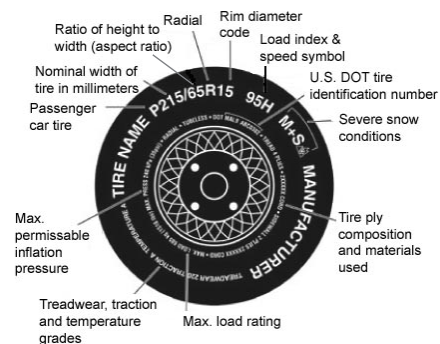

Figure I. Standard Tire Sidewall Information

- P:** The "P" indicates the tire is for passenger vehicles.
- Next number:** This three-digit number gives the width in millimeters of the tire from sidewall edge to sidewall edge. In general, the larger the number, the wider the tire.
- Next number:** This two-digit number, known as the aspect ratio, gives the tire's ratio of height to width. Numbers of 70 or lower indicate a short sidewall for improved steering response and better overall handling on dry pavement.
- P:** The "R" stands for radial. Radial ply construction of tires has been the industry standard for the past 20 years.

TRAILER GUIDELINES

Next number: This two-digit number is the wheel or rim diameter in inches. If you change your wheel size, you will have to purchase new tires to match the new wheel diameter.

Next number: This two- or three-digit number is the tire's load index. It is a measurement of how much weight each tire can support. You may find this information in your owner's manual. If not, contact a local tire dealer. *Note:* You may not find this information on all tires because it is not required by law.

M+S: The "M+S" or "M/S" indicates that the tire has some mud and snow capability. Most radial tires have these markings; hence, they have some mud and snow capability.

Speed Rating: The speed rating denotes the speed at which a tire is designed to be driven for extended periods of time. The ratings range from 99 miles per hour (mph) to 186 mph. These ratings are listed in Table A. *Note:* You may not find this information on all tires because it is not required by law.

Letter Rating	Speed Rating
Q	99 mph
R	106 mph
S	112 mph
T	118 mph
U	124 mph
H	130 mph
V	149 mph
W	168* mph
Y	186* mph

U.S. DOT Tire Identification Number: This begins with the letters "DOT" and indicates that the tire meets all federal standards. The next two numbers or letters are the plant code where it was manufactured, and the last four numbers represent the week and year the tire was built. For example, the numbers 3197 means the 31st week of 1997. The other numbers are marketing codes used at the manufacturer's discretion. This information is used to contact consumers if a tire defect requires a recall.

Tire Ply Composition and Materials Used: The number of plies indicates the number of layers of rubber-coated fabric

in the tire. In general, the greater the number of plies, the more weight a tire can support. Tire manufacturers also must indicate the materials in the tire, which include steel, nylon, polyester, and others.

Maximum Load Rating: This number indicates the maximum load in kilograms and pounds that can be carried by the tire.

Maximum Permissible Inflation Pressure: This number is the greatest amount of air pressure that should ever be put in the tire under normal driving conditions.

Uniform Tire Quality Grading Standards (UTQGS)

Treadwear Number: This number indicates the tire's wear rate. The higher the treadwear number is, the longer it should take for the tread to wear down. For example, a tire graded 400 should last twice as long as a tire graded 200.

Traction Letter: This letter indicates a tire's ability to stop on wet pavement. A higher graded tire should allow you to stop your car on wet roads in a shorter distance than a tire with a lower grade. Traction is graded from highest to lowest as "AA", "A", "B", and "C".

Temperature Letter: This letter indicates a tire's resistance to heat. The temperature grade is for a tire that is inflated properly and not overloaded. Excessive speed, underinflation or excessive loading, either separately or in combination, can cause heat build-up and possible tire failure. From highest to lowest, a tire's resistance to heat is graded as "A", "B", or "C".

Refer to Figure J for additional tire information for light trucks.

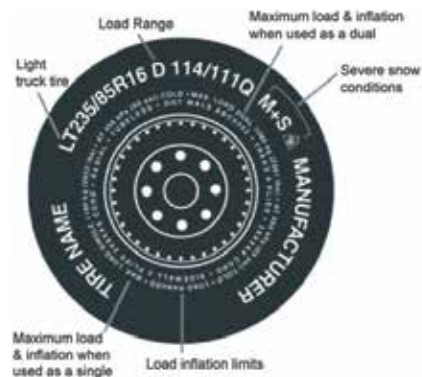

Figure J. UTQGS Tire Information

TRAILER GUIDELINES

Tires for light trucks have other markings besides those found on the sidewalls of passenger tires.

LT: The “LT” indicates the tire is for light trucks or trailers.

ST: An “ST” is an indication the tire is for trailer use only.

Max. Load Dual kg (lbs) at kPa (psi) Cold: This information indicates the maximum load and tire pressure when the tire is used as a dual, that is, when four tires are put on each rear axle (a total of six or more tires on the vehicle).

Max. Load Single kg (lbs) at kPa (psi) Cold: This information indicates the maximum load and tire pressure when the tire is used as a single.

Load Range: This information identifies the tire’s load-carrying capabilities and its inflation limits.

Tire Safety Tips

- Slow down if you have to go over a pothole or other object in the road.
- **DO NOT** run over curbs or other foreign objects in the roadway, and try not to strike the curb when parking.
- Check tire inflation pressure weekly during use to insure the maximum tire life and tread wear.
- **DO NOT** bleed air from tires when they are hot.
- Inspect tires for uneven wear patterns on the tread, cracks, foreign objects, or other signs of wear or trauma.
- Remove bits of glass and foreign objects wedged in the tread.
- Make sure your tire valves have valve caps.
- **ALWAYS** check tire pressure on tow vehicle and trailer before towing. Check tire pressure at least once a month.
- **DO NOT** overload tow vehicle. Check the tire information and loading placard for safe allowable tire loading conditions.

Tire Repair







The proper repair of a punctured tire requires a plug for the hole and a patch for the area inside the tire that surrounds the puncture hole. Punctures through the tread can be repaired if they are not too large, but punctures to the

sidewall should not be repaired. Tires must be removed from the rim to be properly inspected before being plugged and patched.

Replacing Worn or Damaged Tires

Replace the tire before towing the trailer if the tire treads have less than 1/16 inch depth or the telltale bands are visible. Check inflation pressure weekly during use to insure the maximum tire life and tread wear. A bubble, cut or bulge in a side wall can result in a tire blowout. Inspect both side walls of each tire for any bubble, cut or bulge; and replace a damaged tire before towing the trailer.

Table B below will help pinpoint the causes and solutions of tire wear problems.

Wear Pattern		Cause	Solution
	Center Wear	Over inflation.	Adjust pressure to particular load per tire manufacturer.
	Edge Wear	Under inflation.	Adjust pressure to particular load per tire manufacturer.
	Side Wear	Loss of camber or overloading.	Make sure load does not exceed axle rating. Align wheels.
	Toe Wear	Incorrect toe-in.	Align wheels.
	Cupping	Out-of-balance.	Check bearing adjustment and balance tires.
	Flat Spots	Wheel lockup and tire skidding.	Avoid sudden stops when possible and adjust brakes.

WARNING

 **ALWAYS** wear safety glasses when removing or installing force fitted parts. **DO NOT** attempt to repair or modify a wheel. **DO NOT** install an inner-tube to correct a leak through through the rim. If the rim is cracked, the air pressure in the inner tube may cause pieces of the rim to explode (break off) with great force and cause serious eye or bodily injury.

TRAILER GUIDELINES

Wheel Rims

If the trailer has been struck, or impacted, on or near the wheels, or if the trailer has struck a curb, inspect the rims for damage (i.e. being out of round); and replace any damaged wheel. Inspect the wheels for damage every year, even if no obvious impact has occurred.

Wheels, Bearings and Lug Nuts

A loose, worn or damaged wheel bearing is the most common cause of brakes that grab.

To check wheel bearings, jack trailer and check wheels for side-to-side looseness. If the wheels are loose, or spin with a wobble, the bearings must be serviced or replaced. Check inflation pressure weekly during use to insure the maximum tire life and tread wear. Most trailer axles are built with sealed bearings that are not serviceable. Sealed bearings must be replaced as complete units.

3. Check to see if the lug nuts are tight after the first 10, 25 and 50 miles of driving and before each tow thereafter

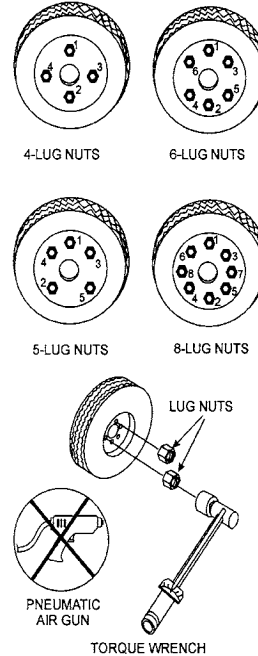

Figure K. Wheel Lug Nuts Tightening Sequence

WARNING

Lug nuts are prone to loosen after initial installation, which can lead to death or serious injury. Check all wheel lug nuts periodically.

Lug Nut Torque Requirements

It is extremely important to apply and maintain proper wheel mounting torque on the trailer. Be sure to use only the fasteners matched to the cone angle of the wheel. Proper procedure for attachment of the wheels is as follows:

1. Start all wheel lug nuts by hand.
2. Torque all lug nuts in sequence. See Figure K. DO NOT torque the wheel lug nuts all the way down. Tighten each lug nut in 3 separate passes as defined by Table C.

Table C. Tire Torque Requirements

Wheel Size	First Pass FT-LBS	Second Pass FT-LBS	Third Pass FT-LBS
12"	20-25	35-40	50-65
13"	20-25	35-40	50-65
14"	20-25	50-60	90-120
15"	20-25	50-60	90-120
16"	20-25	50-60	90-120

NOTICE

NEVER use an pneumatic air gun to tighten wheel lug nuts.

Over-tightening lug nuts will result in breaking the studs or permanently deforming the mounting stud holes in the wheels.

Lights and Signals

Before each tow, check the trailer taillights, stoplights, turn signals and any clearance lights for proper operation.

Replace any broken or burned-out lamps as necessary. Check the wire harness for cuts, fraying or other damage. If it needs replacing, contact your dealer.

WARNING

Improper operating taillights, stoplights and turn signals can cause collisions.

Check all lights before each tow.

TRAILER GUIDELINES

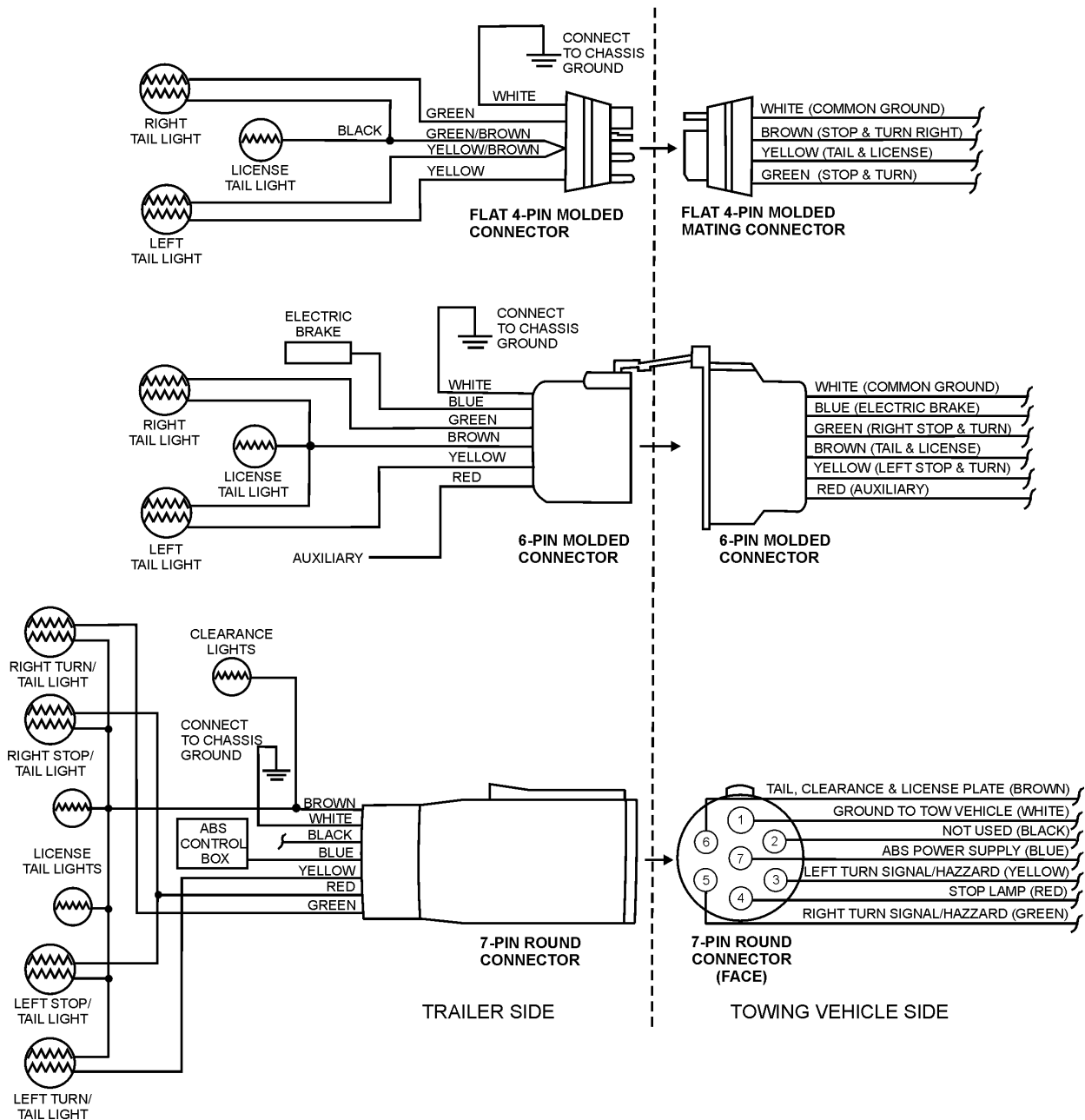
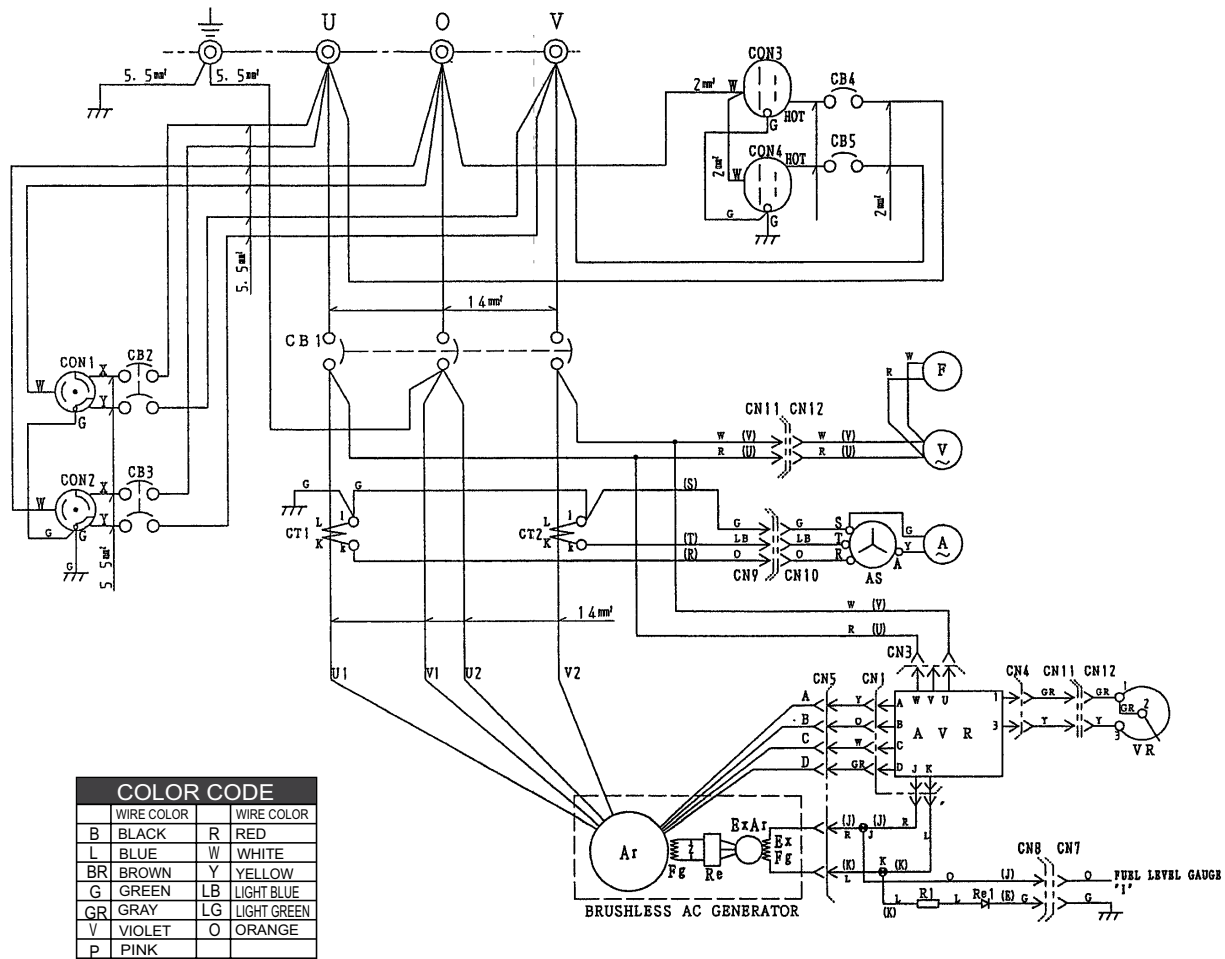

Figure L. Trailer to Tow Vehicle Wiring Diagram

GENERATOR WIRING DIAGRAM



COLOR CODE	
WIRE COLOR	WIRE COLOR
B BLACK	R RED
L BLUE	W WHITE
BR BROWN	Y YELLOW
G GREEN	LB LIGHT BLUE
GR GRAY	LG LIGHT GREEN
V VIOLET	O ORANGE
P PINK	

SYMBOL	DESIGNATION
Ar	MAIN GENERATOR ARMATURE WINDING
Fg	MAIN GENERATOR FIELD WINDING
ExAr	EXCITER ARMATURE WINDING
ExFg	EXCITER FIELD WINDING
Re	RECTIFIER
AVR	AUTOMATIC VOLTAGE REGULATOR
VR	VOLTAGE REGULATOR (RHEOSTAT)
CT 1,2	CURRENT TRANSFORMER
AS	CHANGE-OVER SWITCH, AMMETER
A	AC, AMMETER
V	AC, VOLTMETER
F	FREQUENCY METER
CB1	CIRCUIT BREAKER
CB2,3	CIRCUIT BREAKER
CB4,5	CIRCUIT BREAKER
CON1,2	RECEPTACLE
CON3,4	RECEPTACLE
R1	RESISTOR
Re1	RECTIFIER
J, K	RELAY UNIT

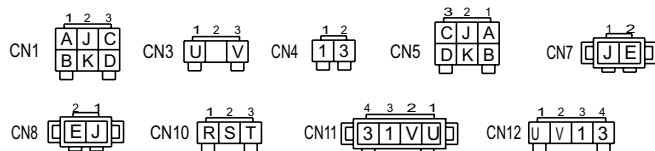

CONNECTER ARRANGEMENT
(WIRING VIEW)

Notice:

1. With no designation use KIV1 : 1.25 mm² lead of designated color.

ENGINE WIRING DIAGRAM

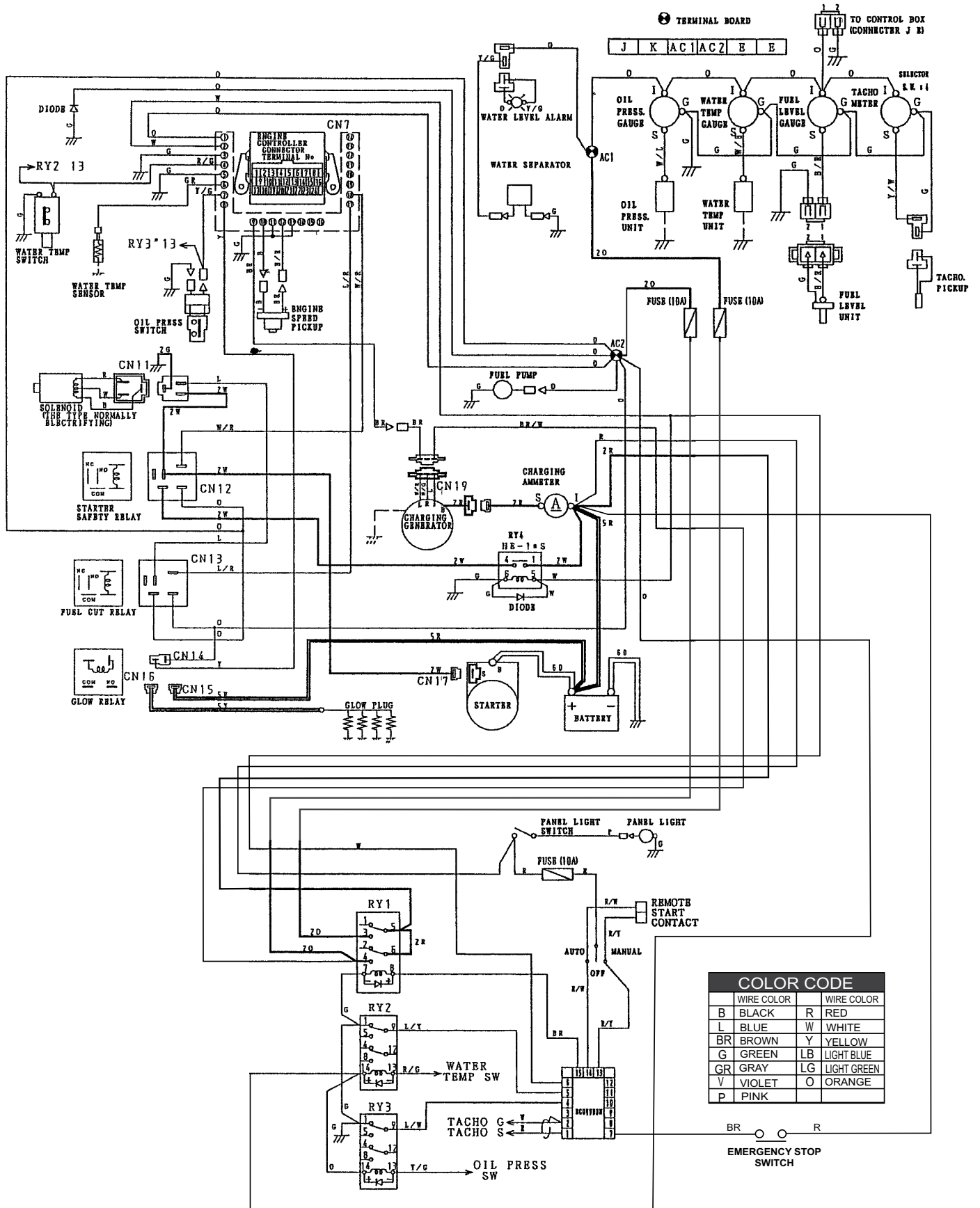

JACKET WATER HEATER WIRING DIAGRAM

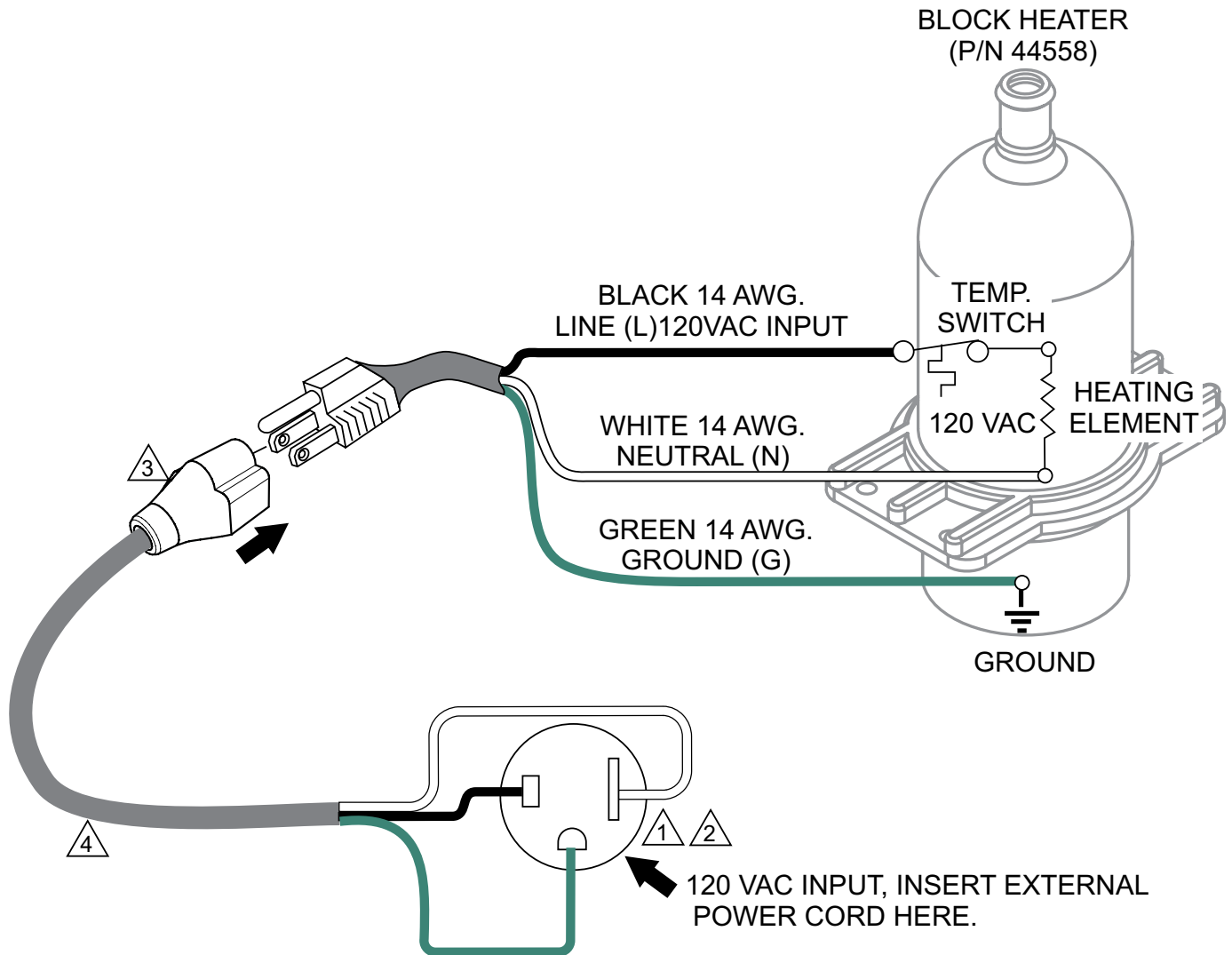

NOTES:

- ① NEMA 5-15, 15A, 120 VAC, P/N EE6176 (HBL5278C/HUBBLE RECEPTACLE).
- ② RECEPTACLE IS MOUNTED ON OUTPUT TERMINAL PANEL ASSY.
- ③ 20 AMP, 5-20R RECEPTACLE, P/N EE6131 (HBL5369C/HUBBLE RECEPTACLE).
- ④ CORD, CAROL 3/C 14 AWG., P/N EE56557.

TROUBLESHOOTING (GENERATOR)

Practically all breakdowns can be prevented by proper handling and maintenance inspections, but in the event of a breakdown, use the table shown below and on the preceding pages for diagnosis of the generator and engine. If the problem cannot be remedied, consult our company's business office or service center.

Troubleshooting (Generator)		
Symptom	Possible Problem	Solution
Voltage Output Weak	AC Voltmeter defective?	Check output voltage using a voltmeter.
	Is wiring connection loose?	Check wiring and repair.
	Is AVR defective?	Replace if necessary.
	Defective Rotating Rectifier?	Check and replace.
	Defective Exciter Field?	Check for approximately 17.3 ohms across J & K on CN1
Low Voltage Output	Is engine speed correct?	Turn engine throttle lever to "High".
	Is wiring connections loose?	Check wiring and repair.
	Defective AVR?	Replace if necessary.
High Voltage Output	Is wiring connections loose?	Check wiring and repair.
	Defective AVR?	Replace if necessary.

TROUBLESHOOTING (ENGINE)

Troubleshooting (Engine)		
Symptom	Possible Problem	Solution
Engine will not start or start is delayed, although engine can be turned over.	No Fuel reaching injection pump?	Add fuel. Check entire fuel system.
	Defective fuel pump?	Replace fuel pump.
	Fuel filter clogged?	Replace fuel filter and clean tank.
	Faulty fuel supply line?	Replace or repair fuel line.
	Compression too low?	Check piston, cylinder and valves. Adjust or repair per engine repair manual.
	Fuel pump not working correctly?	Repair or replace fuel pump.
	Oil pressure too low?	Check engine oil pressure.
	Low starting temperature limit exceeded?	Comply with cold starting instructions and proper oil viscosity.
	Defective battery?	Charge or replace battery.
	Air or water mixed in fuel system?	Check carefully for loosened fuel line coupling, loose cap nut, etc.
At low temperatures engine will not start.	Engine oil too thick?	Refill engine crankcase with correct type of oil for winter environment.
	Defective battery?	Replace battery.
Engine fires but stops soon as starter is switched off.	Fuel filter blocked?	Replace fuel filter.
	Fuel supply blocked?	Check the entire fuel system.
	Defective fuel pump?	Replace fuel pump.
Engine stops by itself during normal operation.	Fuel tank empty?	Add fuel.
	Fuel filter blocked?	Replace fuel filter.
	Defective fuel pump?	Replace fuel pump.
	Mechanical oil pressure shutdown sensor stops the engine due to low oil?	Add oil. Replace low oil shutdown sensor if necessary.
Low engine power, output and speed.	Fuel tank empty?	Replace fuel filter.
	Fuel filter clogged?	Replace fuel filter.
	Fuel tank venting is inadequate?	Ensure that tank is adequately vented.
	Leaks at pipe unions?	Check threaded pipe unions tape and tighten unions as required.
	Speed control lever does not remain in selected position?	See engine manual for corrective action.
	Engine oil level too full?	Correct engine oil level.
	Injection pump wear?	Use No. 2-D diesel fuel only. Check the fuel injection pump element and delivery valve assembly and replace as necessary.

TROUBLESHOOTING (ENGINE — CONTINUED)

Troubleshooting (Engine) - continued		
Symptom	Possible Problem	Solution
Low engine power output and low speed, black exhaust smoke.	Air filter blocked?	Clean or replace air filter.
	Incorrect valve clearances?	Adjust valves per engine specification.
	Malfunction at injector?	See engine manual.
Engine overheats.	Too much oil in engine crankcase?	Drain off engine oil down to uppermark on dipstick.
	Entire cooling air system contaminated/ blocked?	Clean cooling air system and cooling fin areas.
	Fan belt broken or elongated?	Change belt or adjust belt tension.
	Coolant insufficient?	Replenish coolant.
	Radiator net or radiator fin clogged with dust?	Clean net or fin carefully.
	Fan, radiator, or radiator cap defective?	Replace defective part.
	Thermostat defective?	Check thermostat and replace if necessary.
Head gasket defective or water leakage?	Replace parts.	

EXPLANATION OF CODE IN REMARKS COLUMN

The following section explains the different symbols and remarks used in the Parts section of this manual. Use the help numbers found on the back page of the manual if there are any questions.

NOTICE

The contents and part numbers listed in the parts section are subject to change **without notice**. Multiquip does not guarantee the availability of the parts listed.

SAMPLE PARTS LIST

NO.	PART NO.	PART NAME	QTY.	REMARKS
1	12345	BOLT	1	INCLUDES ITEMS W/%
2%		WASHER, 1/4 IN.		NOT SOLD SEPARATELY
2%	12347	WASHER, 3/8 IN. ...	1	MQ-45T ONLY
3	12348	HOSE	A/R	MAKE LOCALLY
4	12349	BEARING	1	S/N 2345B AND ABOVE

NO. Column

Unique Symbols — All items with same unique symbol

(@, #, +, %, or >) in the number column belong to the same assembly or kit, which is indicated by a note in the “Remarks” column.

Duplicate Item Numbers — Duplicate numbers indicate multiple part numbers, which are in effect for the same general item, such as different size saw blade guards in use or a part that has been updated on newer versions of the same machine.

NOTICE

When ordering a part that has more than one item number listed, check the remarks column for help in determining the proper part to order.

PART NO. Column

Numbers Used — Part numbers can be indicated by a number, a blank entry, or TBD.

TBD (To Be Determined) is generally used to show a part that has not been assigned a formal part number at the time of publication.

A blank entry generally indicates that the item is not sold separately or is not sold by Multiquip. Other entries will be clarified in the “Remarks” Column.

QTY. Column

Numbers Used — Item quantity can be indicated by a number, a blank entry, or A/R.

A/R (As Required) is generally used for hoses or other parts that are sold in bulk and cut to length.

A blank entry generally indicates that the item is not sold separately. Other entries will be clarified in the “Remarks” Column.

REMARKS Column

Some of the most common notes found in the “Remarks” Column are listed below. Other additional notes needed to describe the item can also be shown.

Assembly/Kit — All items on the parts list with the same unique symbol will be included when this item is purchased.

Indicated by:

“INCLUDES ITEMS W/(unique symbol)”

Serial Number Break — Used to list an effective serial number range where a particular part is used.

Indicated by:

“S/N XXXXX AND BELOW”

“S/N XXXX AND ABOVE”

“S/N XXXX TO S/N XXX”

Specific Model Number Use — Indicates that the part is used only with the specific model number or model number variant listed. It can also be used to show a part is NOT used on a specific model or model number variant.

Indicated by:

“XXXXX ONLY”

“NOT USED ON XXXX”

“Make/Obtain Locally” — Indicates that the part can be purchased at any hardware shop or made out of available items. Examples include battery cables, shims, and certain washers and nuts.

“Not Sold Separately” — Indicates that an item cannot be purchased as a separate item and is either part of an assembly/kit that can be purchased, or is not available for sale through Multiquip.

SUGGESTED SPARE PARTS

DCA20SPXU2 WHISPERWATT GENERATOR WITH ISUZU BV-4LE2 DIESEL ENGINE

1 to 3 units

<u>QTY.</u>	<u>P/N</u>	<u>DESCRIPTION</u>
5.....	8943142633.....	CARTRIDGE , OIL FILTER
1.....	M1310500803.....	HOSE, RADIATOR UPPER
1.....	M1310500903.....	HOSE, RADIATOR LOWER
1.....	.0602011079.....	RADIATOR CAP
1.....	.0605505070.....	FUEL CAP
1.....	.0602122272.....	UNIT, OIL PRESSURE
1.....	.0602123275	UNIT, WATER TEMPERATURE
6.....	8980374810.....	FILTER, FUEL CARTRIDGE
6.....	8944370220.....	REPAIR KIT, FUEL PUMP
6.....	RR12P	FILTER ELEMENT, 30 MICRON (RACOR OPTION)
3.....	.0602046611.....	FILTER, AIR (ELEMENT)
1.....	.0601870440.....	CIRCUIT BREAKER, 1P, 120V @ 20A
1.....	.0601870441.....	CIRCUIT BREAKER, 2P, 250V @ 50A
1.....	LY2DUS12VDC	RELAY
1.....	8972606490.....	FAN BELT
1.....	.0601820626.....	AUTOMATIC VOLTAGE REGULATOR
1.....	1601840073.....	RHEOSTAT
1.....	.0601840121.....	KNOB, RHEOSTAT

NOTICE

Part number on this Suggested Spare Parts list may supersede/replace the P/N shown in the text pages of this book.

GENERATOR ASSY.

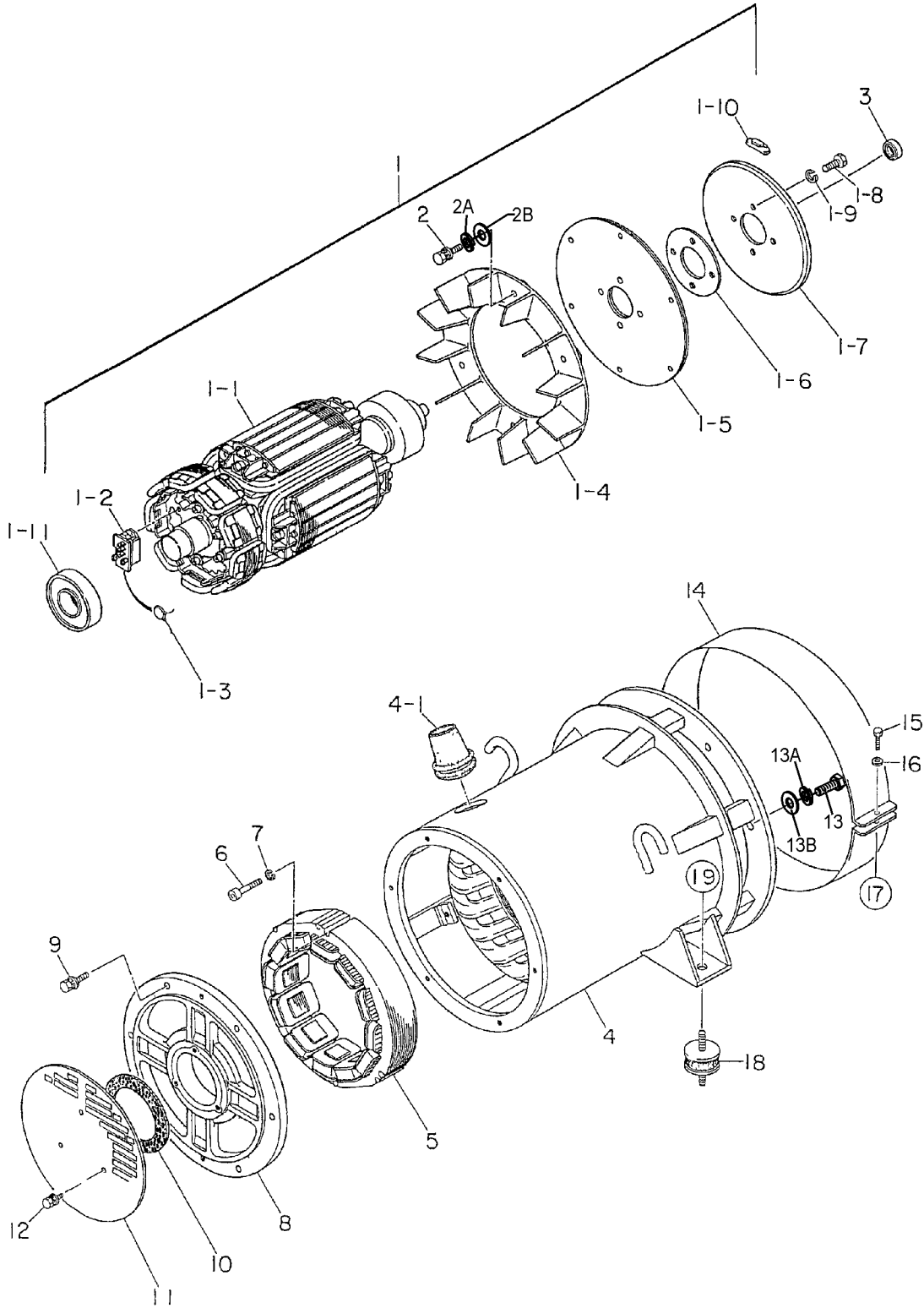

GENERATOR ASSY.

<u>NO.</u>	<u>PART NO.</u>	<u>PART NAME</u>	<u>QTY.</u>	<u>REMARKS</u>
1	B1110001402	ROTOR ASSY.....	1	INCLUDES ITEMS W/#
1-1#		FIELD ASSY.....	1	NOT SOLD SEPARATELY
1-2#	7961025004	RECTIFIER	1	
1-3#	0601822643	SURGE ABSORBER	1	
1-4#	8001070003	FAN	1	
1-5#	8351611004	COUPLING DISC	2	
1-6#	8351612004	COUPLING HUB WASHER	1	
1-7#	B1112300003	BALANCING PLATE	1	WHEN ORDERING, PURCHASE ITEM 1-10
1-8#	0010310025	HEX HEAD BOLT	4	
1-9#	0042510000	WASHER, LOCK	4	
1-10#	0601000209	BALANCING WEIGHT KIT	1	
1-11#	0071906308	BEARING	1	
2	0012308035	HEX HEAD BOLT	6	
2A	0040080000	WASHER, LOCK	6	
2B	0041208000	WASHER, FLAT	6	
3	0070506803	BEARING	1	
4	B1130001503	STATOR ASSY.	1	
4-1	0845041904	GROMMET	1	
5	B113700103	FIELD ASSY. EXCITER	1	
6	0016008045	HEX HD CAP SCREW	3	
7	0042508000	WASHER, LOCK	3	
8	8351315003	END BRACKET	1	
9	0017108035	HEX HEAD BOLT	6	
10	8351312004	PACKING	1	
11	8351331004	SUCTION COVER	1	
12	0017106016	HEX HEAD BOLT	3	
13	0010310030	HEX HEAD BOLT	6	
13A	0040001000	WASHER, LOCK	6	
13B	0041210000	WASHER, FLAT	6	
14	B0155400204	FAN COVER	1	
15	0010106030	HEX HEAD BOLT	1	
16	0041206000	WASHER, FLAT	1	
17	0600815000	NUT	1	
18	M9312600004	RUBBER SUSPENSION	2	
19	0207010000	HEX NUT	2	

CONTROL BOX ASSY.

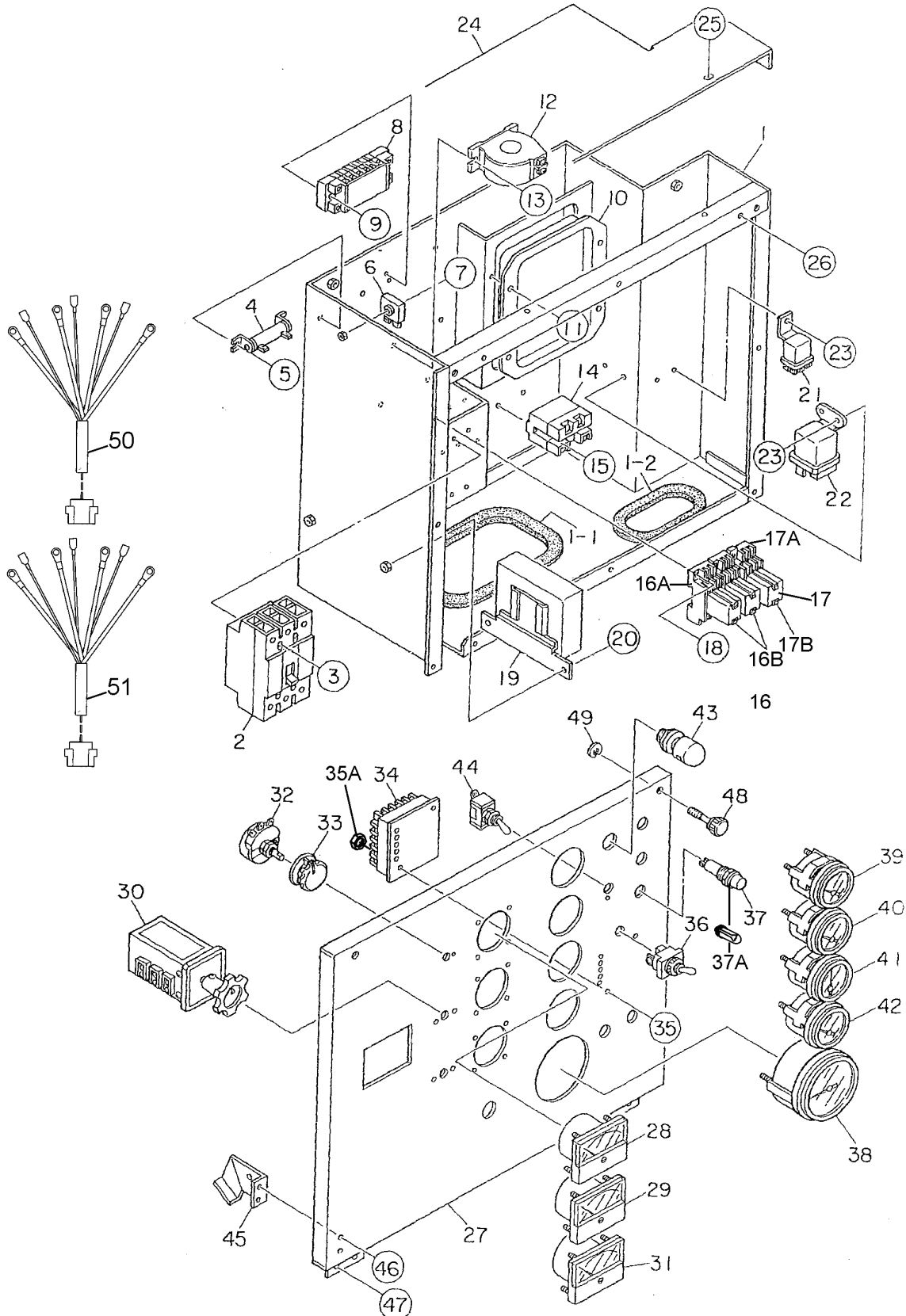

CONTROL BOX ASSY.

<u>NO.</u>	<u>PART NO.</u>	<u>PART NAME</u>	<u>QTY.</u>	<u>REMARKS</u>
1	M1213001402	CONTROL BOX	1	
1-1	0330000480	EDGING	1	
1-2	0330000250	EDGING	1	
2	0601870433	CIRCUIT BREAKER, 3P 90 AMPS	1	
3	0021004075	MACHINE SCREW	4	
4	0601842384	RESISTOR, 20W 50 OHM	1	
5	0027104010	MACHINE SCREW	2	
6	0601823240	RECTIFIER, DE45	3	
7	0027104050	MACHINE SCREW	1	
8	0601815759	TERMINAL BOARD, KT-20 6P	1	
9	0027104020	MACHINE SCREW	2	
10	0601820626	AUTO. VOLT. REGULATOR, NTA-4A-2S	1	
11	0027105016	MACHINE SCREW	4	
12	0601801123	CURRENT TRANSFORMER, 150/5A	2	
13	0027106020	MACHINE SCREW	4	
14	0601826031	RELAY, HE1	1	
15	0027104010	MACHINE SCREW	2	
16	0601824518	RELAY, DC 12V	2	
16A	0601823143	BASE	2	
16B	PYCA1	CLIP	2	REPLACES P/N 0601824400
17	LY2DUS12VDC	RELAY, DC 12V	1	REPLACES P/N 0601827656
17A	PTF08A	BASE.....	1	REPLACES P/N 0601823109
17B	PYCA1	CLIP	1	REPLACES P/N 0601824400
18	0027104020	MACHINE SCREW	6	
19	8973259120	ENGINE CONTROLLER.....	1	REPLACES P/N 0602202523
20	0016906016	HEX HEAD BOLT	2	
21	5825500290	RELAY	2	REPLACES P/N 0602201400
22	8944001061	GLOW RELAY	1	REPLACES P/N 0602202502
23	0027105016	MACHINE SCREW	4	
24	M1213500803	CONTROL BOX COVER	1	
25	0016906016	HEX HEAD BOLT	5	
26	0016906015	HEX HEAD BOLT	9	

CONTROL BOX ASSY. (CONTINUED)

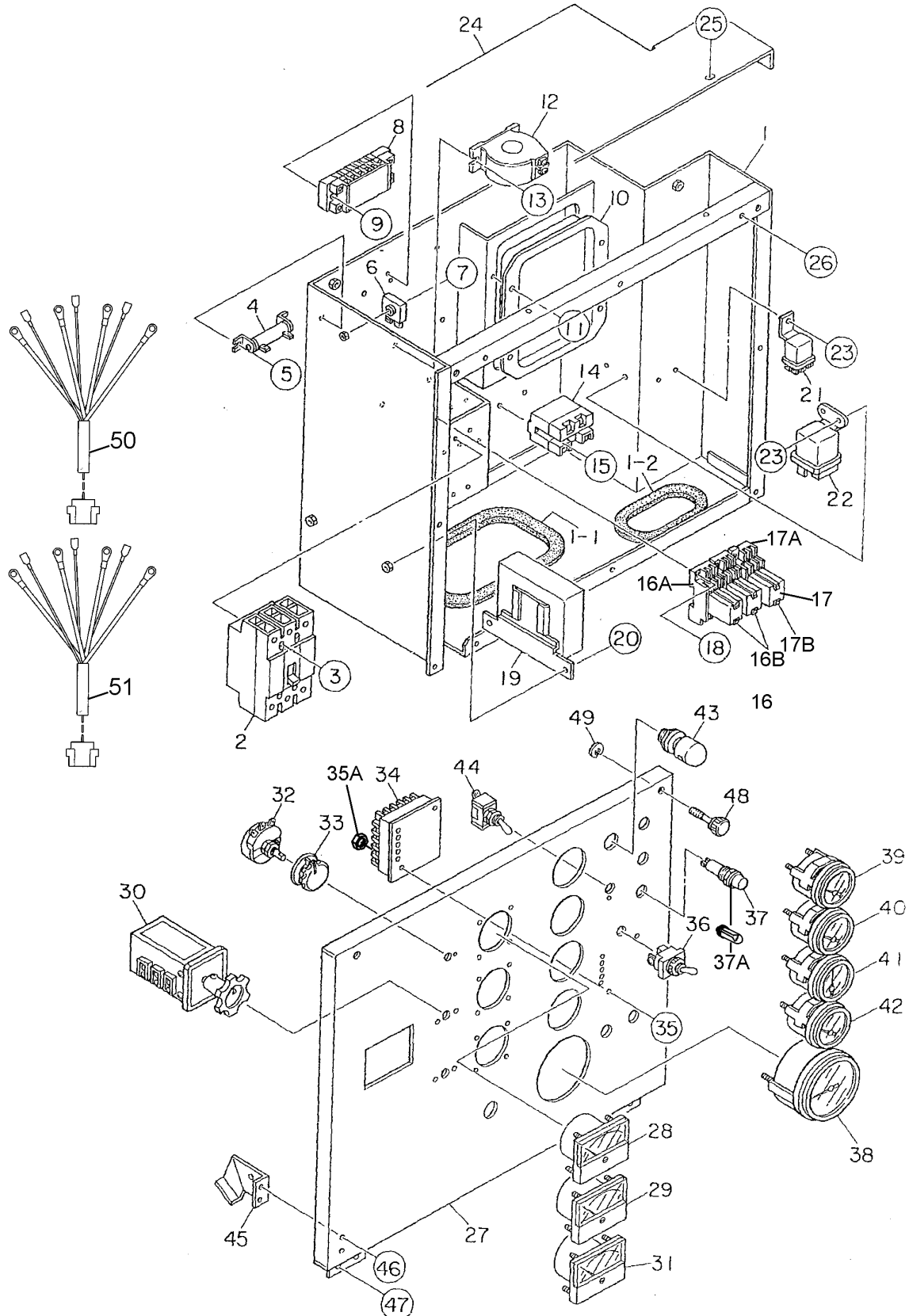

CONTROL BOX ASSY. (CONTINUED)

NO.	PART NO.	PART NAME	QTY.	REMARKS
27	M1223001003	CONTROL PANEL	1	
28	0601807641	FREQUENCY METER, 45~65Hz 240V	1	
29	0601806844	AC AMMETER, 0~150A	1	
30	0601801040	AMMETER, CHANGE-OVER SWITCH	1	
31	0601800271	AC VOLTMETER, 0~300V	1	
32	0601840073	RHEOSTAT (VR), 2W 1K OHM	1	
33	0601840121	KNOB	1	
34	0602202545	CONTROLLER, ECU-9988N	1	
35	0027104040	MACHINE SCREW	2	
35A	0207004000	HEX NUT	2	
36	0601831340	SWITCH, MPEC	1	
37	0602103092	ALARM LAMP, PL-05	1	
37A	0601810245	BULB, DC 18V	1	
38	0602120095	TACHOMETER	1	
39	0602122093	OIL PRESSURE GAUGE	1	
40	0602123090	WATER TEMP. GAUGE	1	
41	0602121080	CHARGING AMMETER	1	
42	0602125090	FUEL GAUGE	1	
43	0601810141	PANEL LIGHT	1	
44	0601831330	SWITCH, PANEL LIGHT	1	
45	M1223100104	STOPPER	1	
46	0027105010	MACHINE SCREW	2	
47	0027105010	MACHINE SCREW	4	
48	M9220100004	SET SCREW	2	
49	0080200007	SNAP RING	2	
50	M1246704404	WIRE HARNESS, GENERATOR	1	
51	M1357201902	WIRE HARNESS, ENGINE	1	

ENGINE AND RADIATOR ASSY.

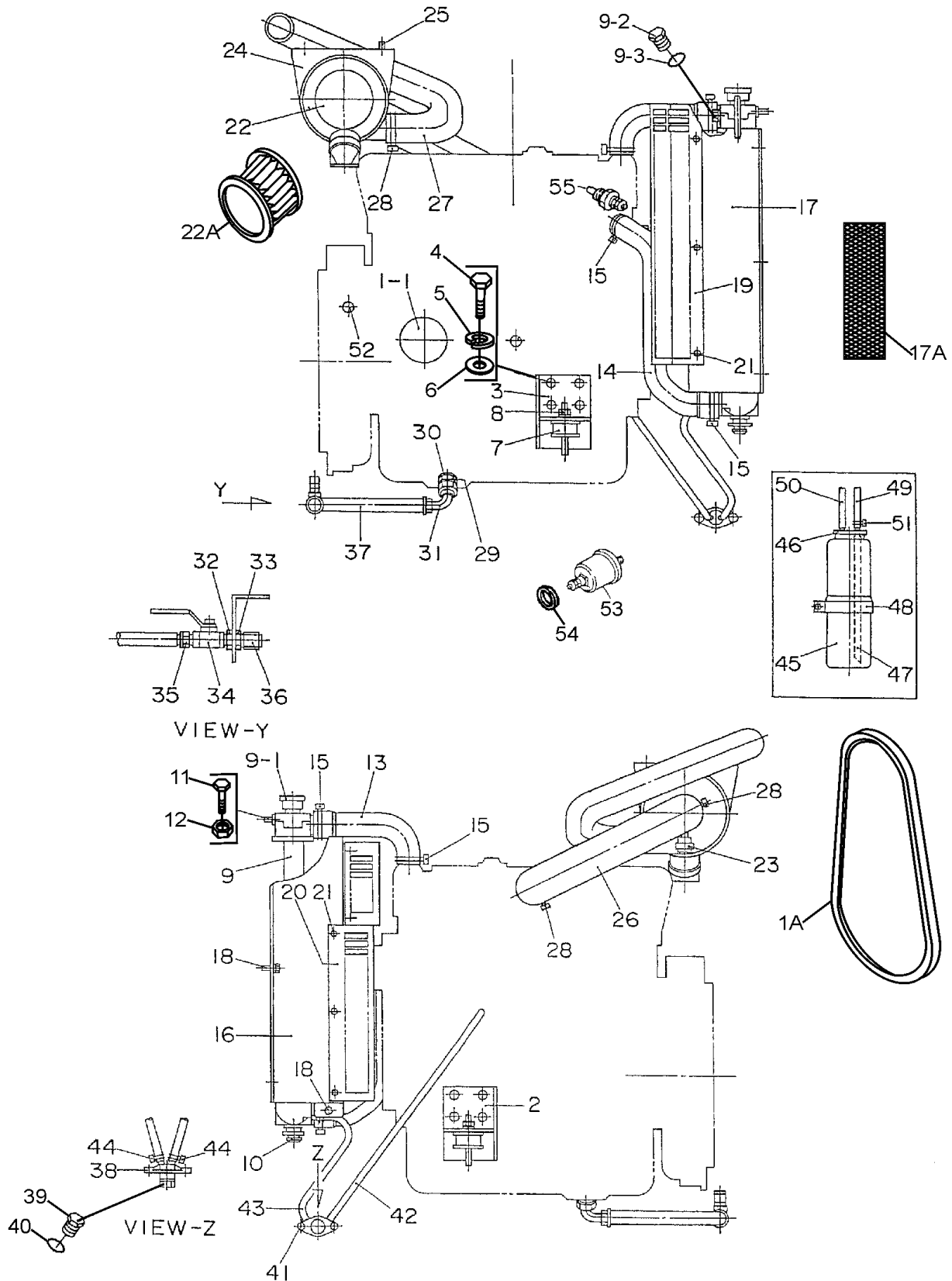

ENGINE AND RADIATOR ASSY.

<u>NO.</u>	<u>PART NO.</u>	<u>PART NAME</u>	<u>QTY.</u>	<u>REMARKS</u>
1	M1923200104	ENGINE, ISUZU 4LE2	1	
1A	8972606490	FAN BELT	1	
1-1	8943142633	OIL FILTER CARTRIDGE	1	
2	M1303200304	ENGINE FOOT	1	
3	M1305200204	ENGINE FOOT	1	
4	0010310025	HEX HEAD BOLT	8	
5	0040010000	WASHER, LOCK	8	
6	0041210000	WASHER, FLAT	8	
7	0605000066	RUBBER SUSPENSION	2	
8	0207010000	HEX NUT	2	
9	M1923200094	RADIATOR	1	
9-1	0602011079	RADIATOR CAP	1	
9-2	M9200100904	PLUG	1	
9-3	0150000016	O-RING	1	
10	M9312200104	RUBBER MOUNT	2	
11	0016908040	HEX HEAD BOLT	2	
12	0207008000	HEX NUT	2	
13	M1310500803	RADIATOR HOSE, UPPER	1	
14	M1310500903	RADIATOR HOSE, LOWER	1	
15	0605515069	HOSE BAND	4	
16	M1310200003	FAN SHROUD	1	
17	M1310200103	FAN SHROUD	1	
17A	M1493105004	ACCOUSTIC SHEET	1	
18	0016908020	HEX HEAD BOLT	8	
19	M1310300703	FAN GUARD	1	
20	M1310300804	FAN GUARD	1	
21	0016908020	HEX HEAD BOLT	8	
22	0602046531	AIR CLEANER	1	
22A	0602046611	AIR CLEANER ELEMENT	1REPLACES 0602046321
23	0602040690	AIR CLEANER INDICATOR	1	
24	0602040552	AIR CLEANER BRACKET	1	
25	0016908030	HEX HEAD BOLT	2	
26	M1373100303	AIR CLEANER HOSE	1	
27	M1373100503	AIR CLEANER HOSE	1	
28	0605515139	HOSE BAND	3	
29	0602022560	ADAPTER	1	
30	M1320300304	PACKING	1	

ENGINE AND RADIATOR ASSY. (CONTINUED)

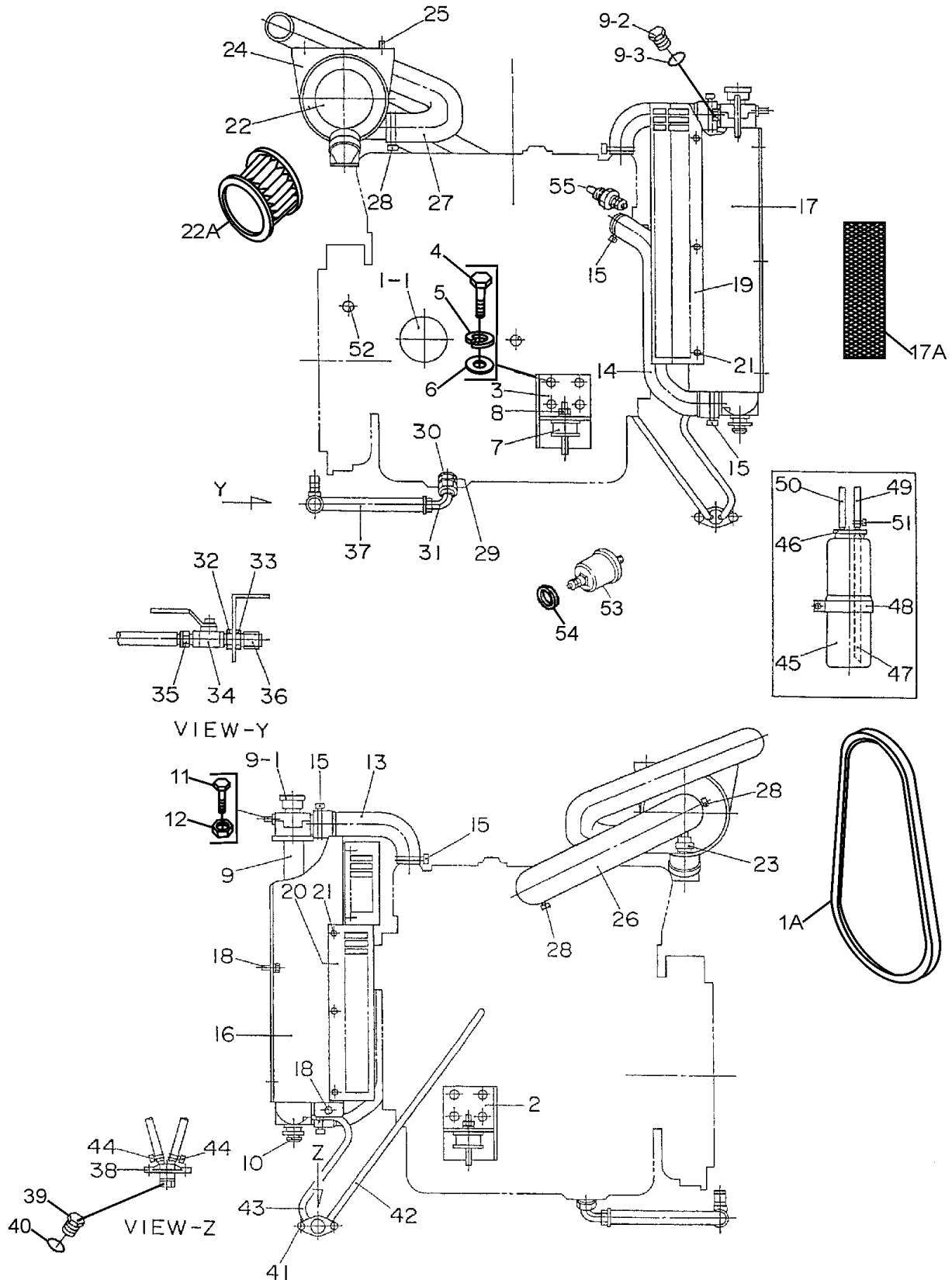

ENGINE AND RADIATOR ASSY. (CONTINUED)

<u>NO.</u>	<u>PART NO.</u>	<u>PART NAME</u>	<u>QTY.</u>	<u>REMARKS</u>
31	0602022561	90 DEGREE ELBOW	1	
32	0603306590	CONNECTOR	1	
33	0603300285	LOCKNUT	1	
34	0605511395	VALVE	1	
35	0603306395	HOSE JOINT	1	
36	0602021070	CAP	1	
37	0269200280	DRAIN HOSE	1	
38	M9602000003	DRAIN JOINT	1	
39	M9200200004	PLUG	1	
40	0150000018	O-RING	1	
41	0016906020	HEX HEAD BOLT	2	
42	0199900600	DRAIN HOSE	1	
43	0199900500	DRAIN HOSE	1	
44	0605515106	HOSE BAND	4	
45	M9300100003	RESERVE TANK	1	
46	M9300100003	RESERVE TANK CAP	1	
47	0199100215	HOSE	1	
48	M1317100004	RESERVE TANK BRACKET	1	
49	0199100350	HOSE	1	
50	0193600850	HOSE	1	
51	0605515106	HOSE BAND	2	
52	0602120481	TACHOMETER PICK UP	1	
53	0602122272	OIL PRESSURE UNIT	1	
54	M9200100004	ADAPTER	1	
55	0602123275	WATER TEMPERATURE UNIT	1	
56	M1353800004	CLAMPER ROD	1	
57	0016908020	HEX HEAD BOLT	2	
58	M1357300104	CLAMPER ROD	1	
59	0016910020	HEX HEAD BOLT	2	

OUTPUT TERMINAL ASSY.

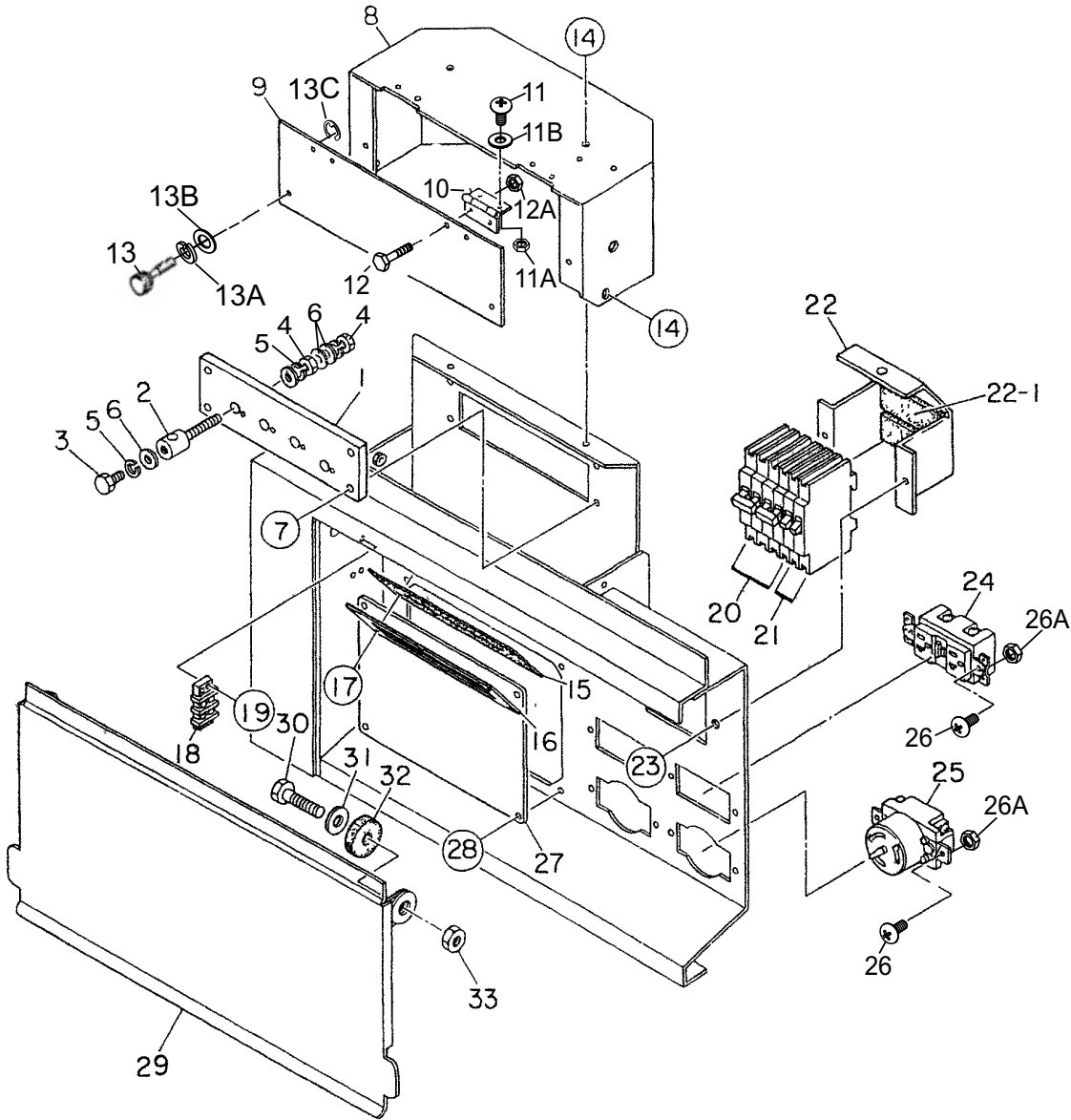

NOTICE

When ordering any painted panel SERVPRO® must add the digit 2 after the part number, this will indicate that the panel color is WHITE.

Once the panel has been received it should be painted Sherwin-Williams (SERVPRO® Green), Product PGS 860083, color Pantone 368C

OUTPUT TERMINAL ASSY.

<u>NO.</u>	<u>PART NO.</u>	<u>PART NAME</u>	<u>QTY.</u>	<u>REMARKS</u>
1	M1230700203	TERMINAL PANEL	1	
2	M9220000204	OUTPUT TERMINAL BOLT	4	
3	M9220000104	TIE BOLT	4	
4	0039308000	HEX BRASS NUT	8	
5	0040008000	WASHER, LOCK	12	
6	0041408000	WASHER, FLAT	16	
7	0016906025	HEX HEAD BOLT	4	
8	M1236101503	TERMINAL COVER	1	
9	M1236100404	OUTPUT WINDOW	1	
10	0605010040	HINGE	2	
11	0027103010	MACHINE SCREW	4	
11A	0030003000	HEX HEAD NUT	4	
11B	0041203000	WASHER, FLAT	4	
12	0027103010	MACHINE SCREW	4	
12A	0030003000	HEX HEAD NUT	4	
13	M9220100804	SET SCREW	2	
13A	0040006000	WASHER, LOCK	2	
13B	0041206000	WASHER, FLAT	2	
13C	0080200005	RETAINING RING	2	
14	0016906016	HEX HEAD BOLT	4	
15	M1236400004	CABLE OUTLET COVER	1	
16	M1236300004	CABLE OUTLET COVER SUPPORTER	1	
17	0016906020	HEX HEAD BOLT	6	
18	0601815194	TERMINAL	1	
19	0027104016	MACHINE SCREW	2	
20	0601870441	CIRCUIT BREAKER, 2P 50A	2	
21	0601870440	CIRCUIT BREAKER, 1P 20A	2	
22	M1260700404	BREAKER FITTING COVER	1	
22-1	0222100080	RUBBER CUSHION	2	
23	0016906020	HEX HEAD BOLT	2	
24	0601814013	RECEPTACLE, 125V 20A (GF-20LA)	2	
25	0601812538	RECEPTACLE, 250V 50A (CS6369)	2	
26	0027104016	MACHINE SCREW	8	
26A	0207004000	HEX NUT	8	
27	M1236400104	COVER	1	
28	0016906016	HEX HEAD BOLT	4	
29	M1236100503	TERMINAL COVER	1	
30	0010112045	HEX HEAD BOLT	2	
31	0041212000	WASHER, FLAT	2	
32	M9310200004	RUBBER STAY	2	
33	0030012000	HEX NUT	2	

BATTERY ASSY.

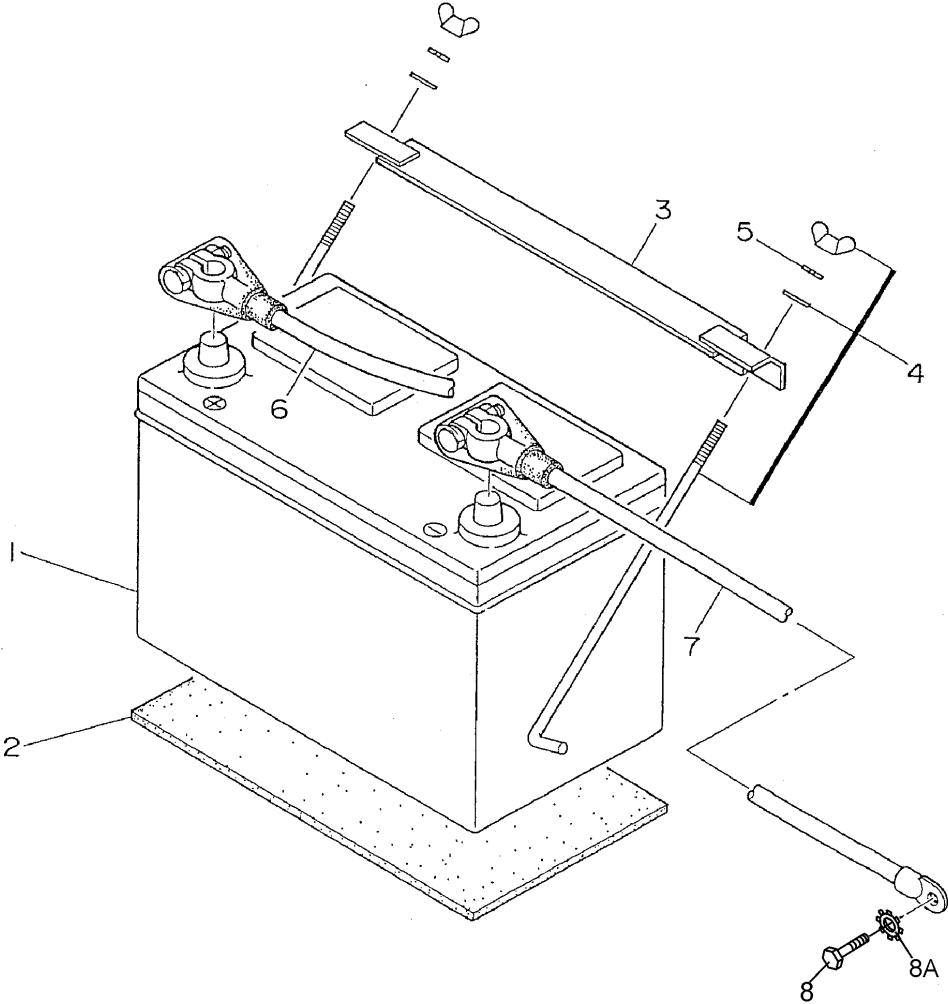

BATTERY ASSY.

<u>NO.</u>	<u>PART NO.</u>	<u>PART NAME</u>	<u>QTY.</u>	<u>REMARKS</u>
1	0602220185	BATTERY	1	
2	B9310500014	BATTERY SHEET	1	
3	M9103000304	BATTERY BAND	1	
4	0602220920	BATTERY BOLT SET	2	
5	0040006000	WASHER, LOCK	2	
6	M1348400204	BATTERY CABLE	1	
7	M2346400104	BATTERY CABLE	1	
8	0016910020	HEX HEAD BOLT	1	
8A	0040510000	TOOTHED WASHER	1	

MUFFLER ASSY.

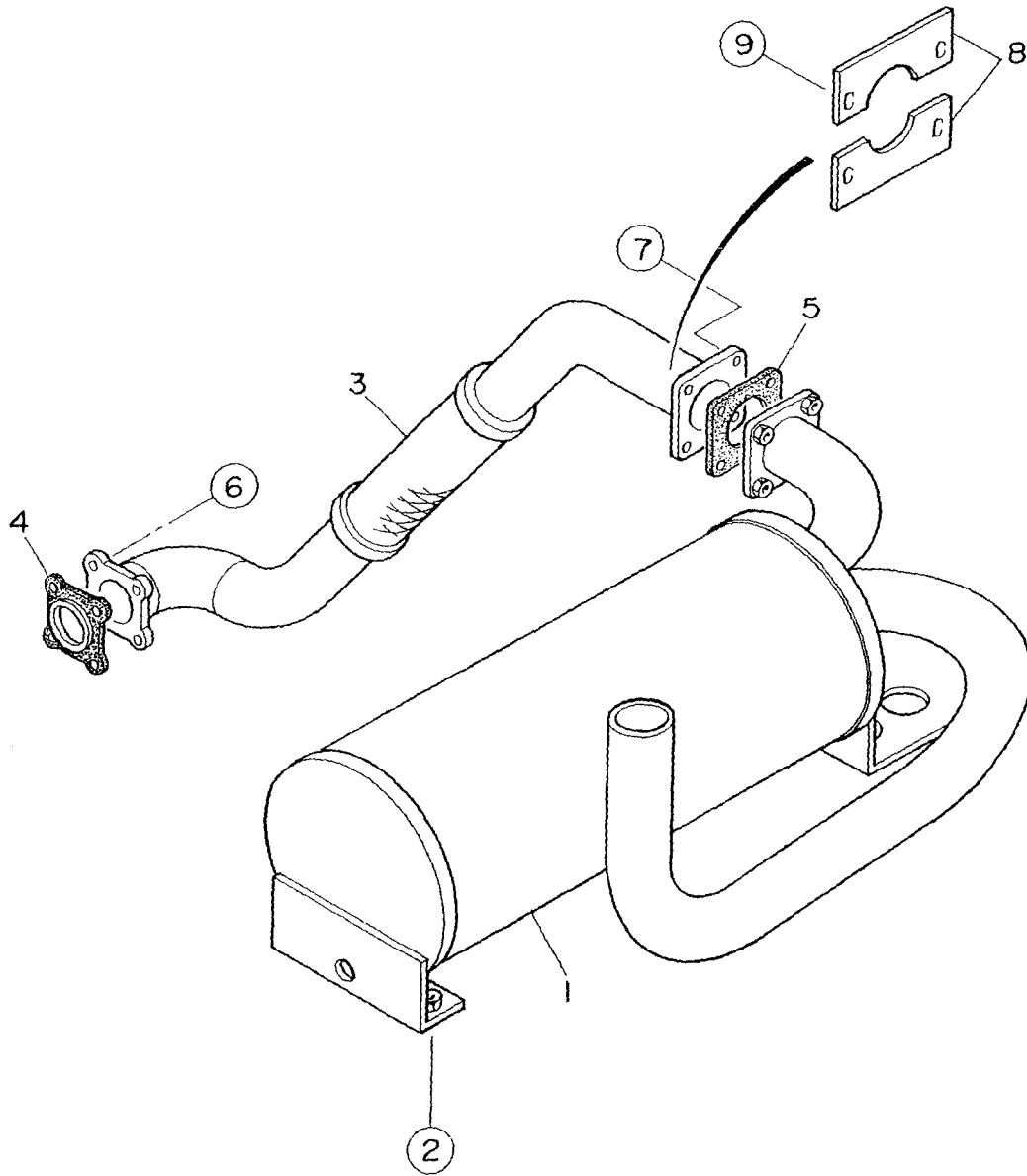

MUFFLER ASSY.

<u>NO.</u>	<u>PART NO.</u>	<u>PART NAME</u>	<u>QTY.</u>	<u>REMARKS</u>
1	M1330100803	MUFFLER	1	
2	0016908020	HEX HEAD BOLT	4	
3	M1333002803	EXHAUST PIPE	1	
4	8970420280	GASKET	1REPLACES 0602320100
5	M1333200014	GASKET	1	
6	0207008000	HEX NUT	4	
7	0016908035	HEX HEAD BOLT	4	
8	M1330400804	COVER	2	
9	0016906016	HEX HEAD BOLT	4	

FUEL TANK ASSY. (INTERNAL)

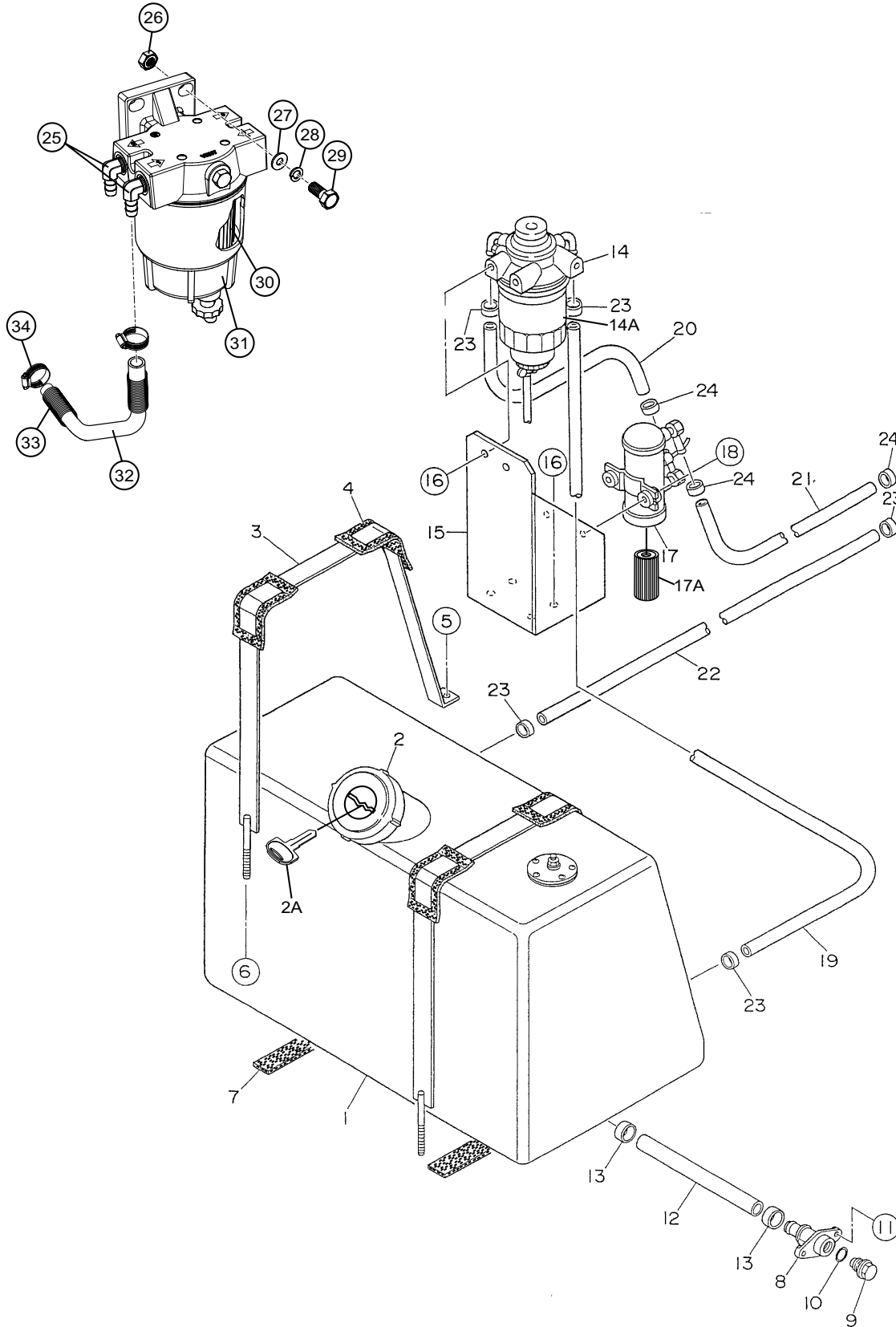

FUEL TANK ASSY. (INTERNAL)

<u>NO.</u>	<u>PART NO.</u>	<u>PART NAME</u>	<u>QTY.</u>	<u>REMARKS</u>
1	M1363000212	FUEL TANK	1	
2	Y0605505073	LOCKING, FUEL CAP	1	
2A	EE57348	KEY, FUEL CAP	1	
3	M1363200004	TANK BAND	2	
4	M9310500104	SUPPORTER SHEET	4	
5	0016908020	HEX HEAD BOLT	2	
6	0207308000	SUPER LOCK NUT	2	
7	0222100080	RUBBER SHEET	4	
8	M9200000003	DRAIN JOINT	1	
9	M9200200004	DRAIN BOLT	1	
10	0150000018	O-RING	1	
11	0016906020	HEX HEAD BOLT	2	
12	M1363400104	DRAIN HOSE	1	
13	0605515198	HOSE BAND	2	
14	8943672922	FUEL FILTER	1	REPLACES 0602042202
14A	8980374810	FUEL FILTER CARTRIDGE	1	REPLACES 0602042700
15	M1366700104	FUEL FILTER BRACKET	1	
16	0016908020	HEX HEAD BOLT	2	
17	8970398340	FUEL PUMP	1	REPLACES 0602023177
17A	8944370220	REPAIR KIT, FUEL PUMP.....	1	REPLACES 0602042425
18	0016906025	HEX HEAD BOLT	2	
19	0191200900	SUCTION HOSE	1	
20	0191200300	SUCTION HOSE	1	
21	0191200650	SUCTION HOSE	1	
22	0191201100	RETURN HOSE	1	
23	0605515108	HOSE BAND	5	
24	0605515198	HOSE BAND	3	
25		ELBOW, 1/4" MP X 5/16" HB. 90°	2	OBTAIN LOCALLY
26	10024	NUT NYLOC, 1/4-20	2	
27	0948	WASHER, FLAT SAE	1	
28	0181 B	WASHER, LOCK 1/4 MED	1	
29		BOLT, 1/4-20 X 1	1	OBTAIN LOCALLY
30	RR12P	FILTER ELEMENT 30 MICRON.....	1	RACOR OPTION
31	120AP	WATER SEPARATOR	1	
32	60028	HOSE, FUEL 5/16" X 22"	1	
33		SPLIT LOOM 5/8 X 18"	1	OBTAIN LOCALLY
34	6109152	CLAMP, FUEL HOSE	2	

FUEL TANK ASSY. (TRAILER MOUNTED)

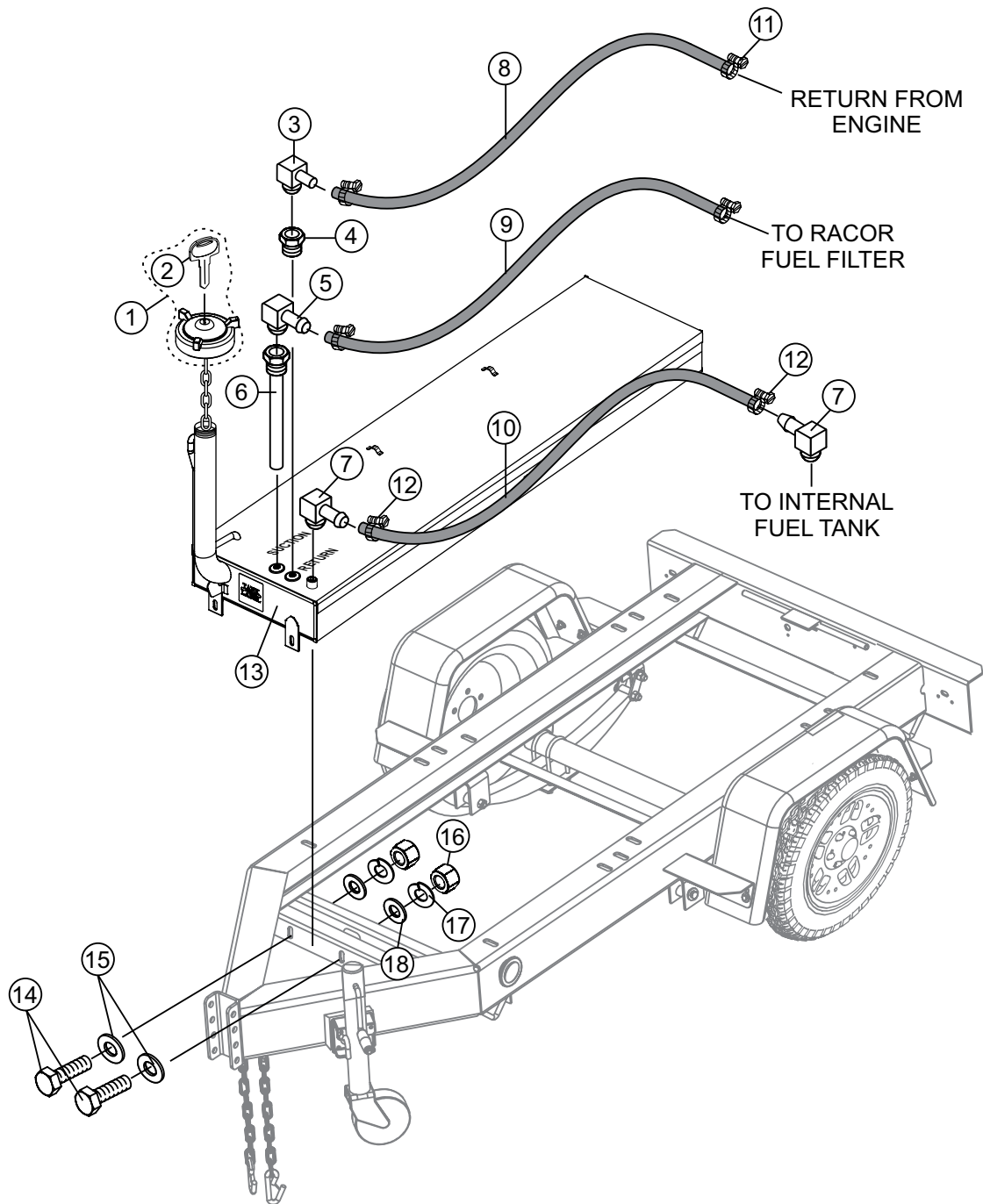

FUEL TANK ASSY. (TRAILER MOUNTED)

<u>NO.</u>	<u>PART NO.</u>	<u>PART NAME</u>	<u>QTY.</u>	<u>REMARKS</u>
1	EE35976	FUEL CAP WITH KEY	1	
2	EE57348	KEY, FUEL CAP	1	
3	6109204	FITTING, HOSE	1	
4	5284	BUSHING, HEX PIPE 3/8 X 1/4"BRASS	1	
5	84454	ELBOW BRASS 1/4 MALE NPT	2	
6	PICKUPTUBE	PICK UP TUBE	1	
7		ELBOW, 3/4" HB-1/2" MP 90°	1	OBTAIN LOCALLY
8	6635BULK	FUEL HOSE 1/4, 65"	1	
9	60028	FUEL HOSE 5/16, 25"	1	
10		FUEL HOSE 3/4" CUT TO LENGTH	1	OBTAIN LOCALLY
11	6109152	CLAMP, FUEL HOSE	4	
12		CLAMP, FUEL HOSE #12	2	OBTAIN LOCALLY
13	EE52009	TANK, FUEL 41 GAL.	1	
14	6109210	BOLT, 1/2-13 X 1-1/2"	2	
15	13211	WASHER, FLAT 1/2 X 1-1/4 USS	2	
16	6109160	NUT, 1/2"	2	
17	6109810	WASHER, LOCK 1/2"	2	
18	6109170	WASHER, FLAT 1/2 X 1	2	

TRAILER ASSY.

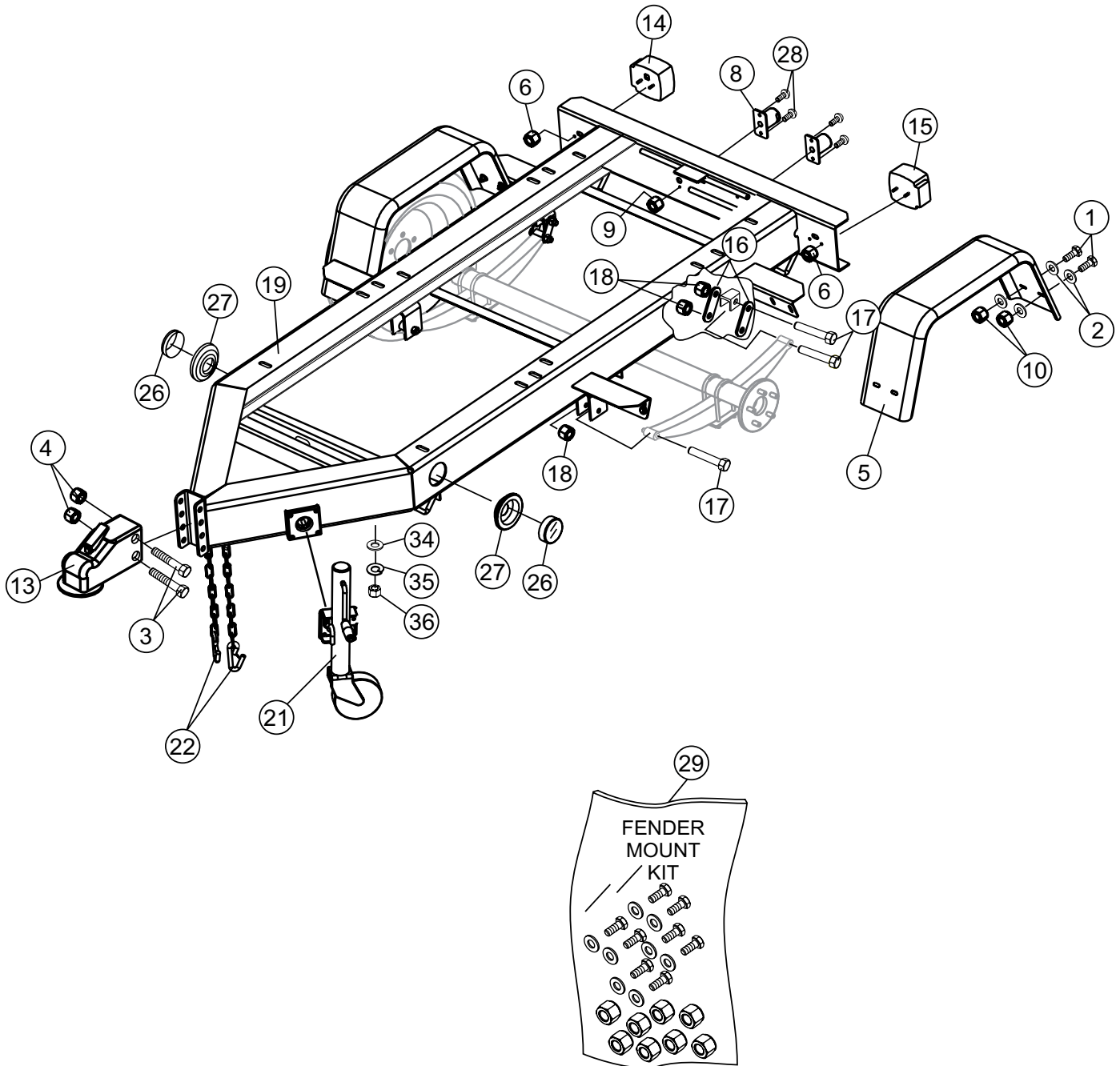

TRAILER ASSY.

<u>NO.</u>	<u>PART NO.</u>	<u>PART NAME</u>	<u>QTY.</u>	<u>REMARKS</u>
1#	0205	SCREW, HHC 3/8 - 16 x 1	8	
2#	4001	WASHER, FLAT USS 3/8 PLD	16	
3	9502	SCREW, HHC 5/8 - 11 x 4-1/2 GR8	2	
4	9503	NUT, NYLOC 5/8 - 11	2	
5	9505	FENDER, 8 x 30 x 13	2	
6\$%		NUT	4	
8	9514	LIGHT ASM., LICENSE PLATE	2	
9	10019	NUT, NYLOC 10-32	4	
10#	10133	NUT, NYLOC 3/8 - 16	8	
13	29228	COUPLER, 2" BALL 600# GVWR	1	
14	29242	LIGHT, TAIL RT (CURB) SIDE M440.....	1	INCLUDES ITEMS W/ \$
15	29243	LIGHT, TAIL LT (ROAD) SIDE M440L	1	INCLUDES ITEMS W/ %
16	29247	SHACKLE, AXLE MOUNTING	4	
17	29248	SCREW, HHC 9/16 - 18	6	
18	29249	NUT, 9/16-18 AXLE MOUNTING, N-2	6	
19	29370	FRAME, W/ A TRLRMP	1	
21	29496	JACK, SIDEWIND 10", BOLT THRU	1	
22	29572	CHAIN ASSY., SAFETY 7600 LB	2	
26	29898	LIGHT, 2-1/2 SIDE MARKER, AMBER	2	
27	29900	GROMMET W/ WIRE KIT, 2-1/2",	2	
28	5065 B	SCREW, PHP 10 - 32 x 1/2	4	
29	29754	FENDER MOUNT KIT	1	INCLUDES ITEMS W/#

BATTERY CHARGER ASSY.

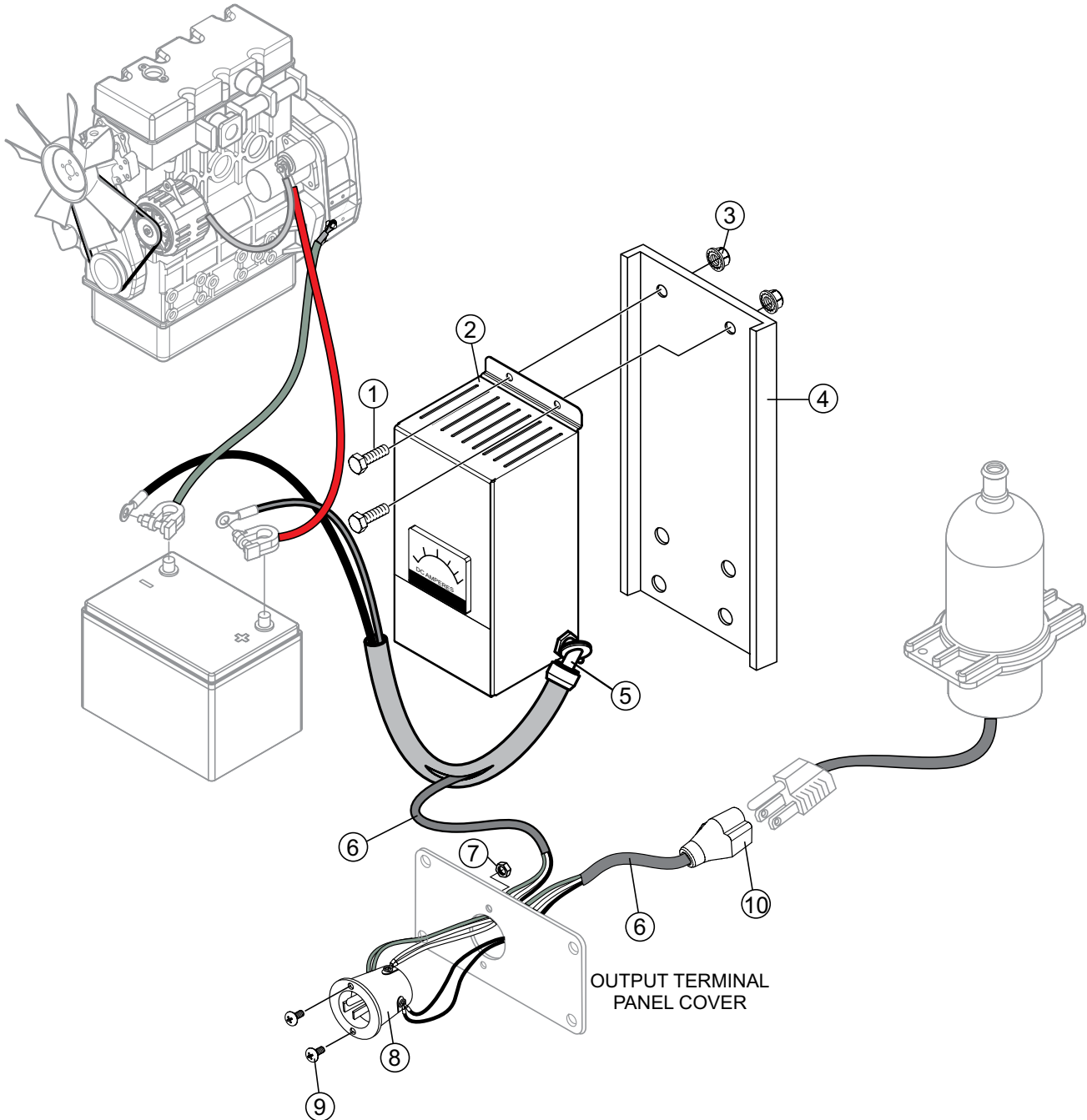

BATTERY CHARGER ASSY.

<u>NO.</u>	<u>PART NO.</u>	<u>PART NAME</u>	<u>QTY.</u>	<u>REMARKS</u>
1		SCREW, 10-24 X 1/2"	2	OBTAIN LOCALLY
2		NUT, KEP (W/STAR WASHER).....	2	OBTAIN LOCALLY
3	LC125002	CHARGER, BATTERY 12V, 3A	1	
4	34530	BRACKET, BATTERY CHARGER	1	
5	EE6009	FITTING, CONDUIT, 90°, NON-METALLIC	1	
6	EE56557	CORD, CAROL 3/C 14 AWG.....	AR.....	1PC = 1FT.
7	OEMAA8	HEX NUT, 4MM	2	
8	HBL5278C	INLET FLANGE, NEMA 15A 125V	1	
9	7538070	SCREW, PHILLIPS HD.	2	
10	HBL5369C	CONNECTOR, 20 AMP ,125V	1	

JACKET WATER HEATER ASSY.

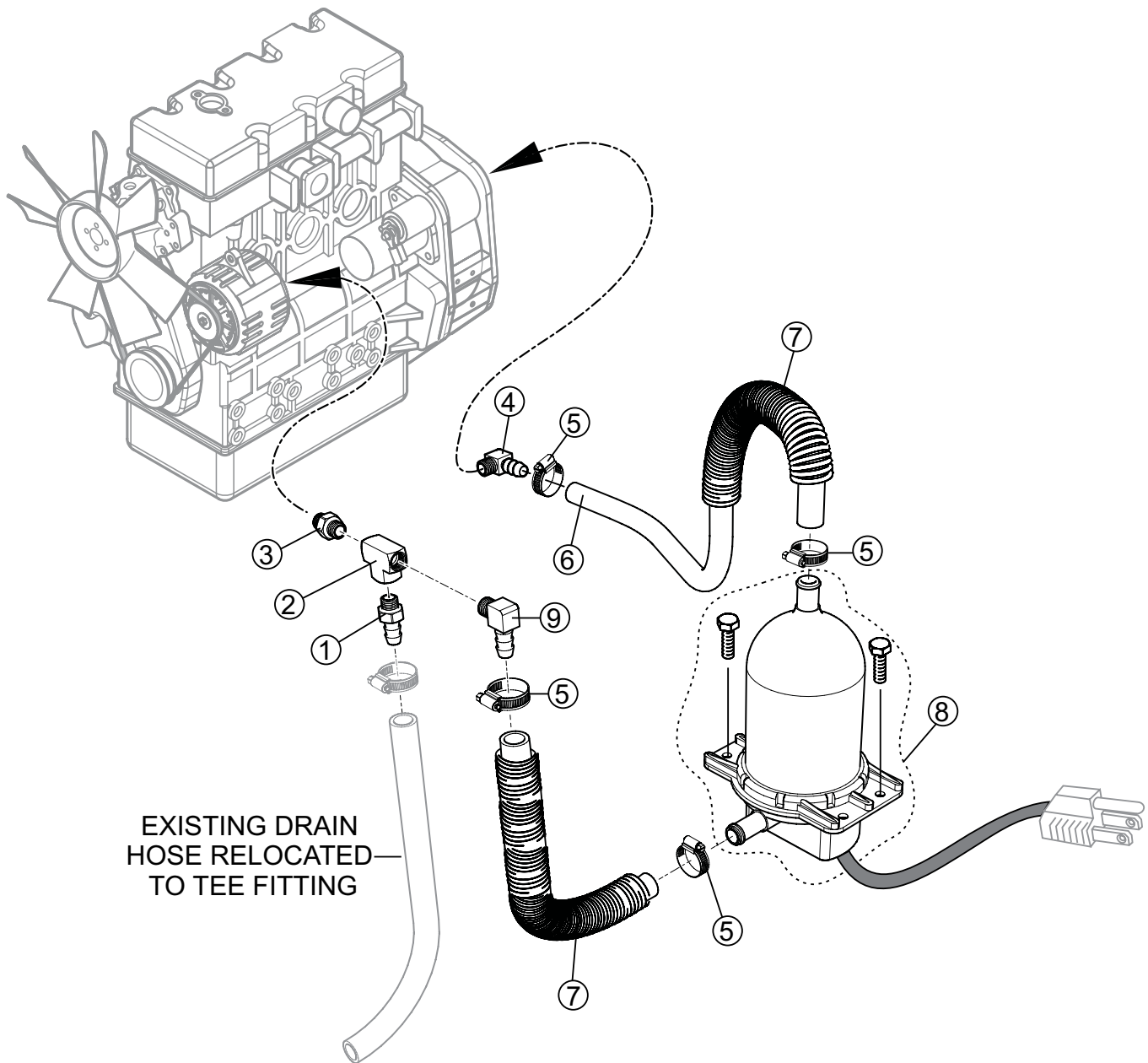

JACKET WATER HEATER ASSY.

<u>NO.</u>	<u>PART NO.</u>	<u>PART NAME</u>	<u>QTY.</u>	<u>REMARKS</u>
1		1/4" MP X 5/16 HB NIPPLE	1	OBTAIN LOCALLY
2		1/4 X 1/4 1/4" FEMALE PIPE TEE	1	OBTAIN LOCALLY
3		1/4 X 1/4 MALE TO MALE PIPE NIPPLE....	1	OBTAIN LOCALLY
4		3/8" MP X 5/8 HB 90° ELBOW	1	OBTAIN LOCALLY
5		HOSE CLAMP #10	4	OBTAIN LOCALLY
6		HEATER HOSE, 5/8" ID X 30" LONG	1	OBTAIN LOCALLY
7		SPLIT LOOM, 1 " X 20"	2	OBTAIN LOCALLY
8	TPS051GT10000	HEATER, 500W, 120 VAC	1	
9		1/4" MP X 5/8" HB 90° ELBOW	1	OBTAIN LOCALLY

ENCLOSURE ASSY.

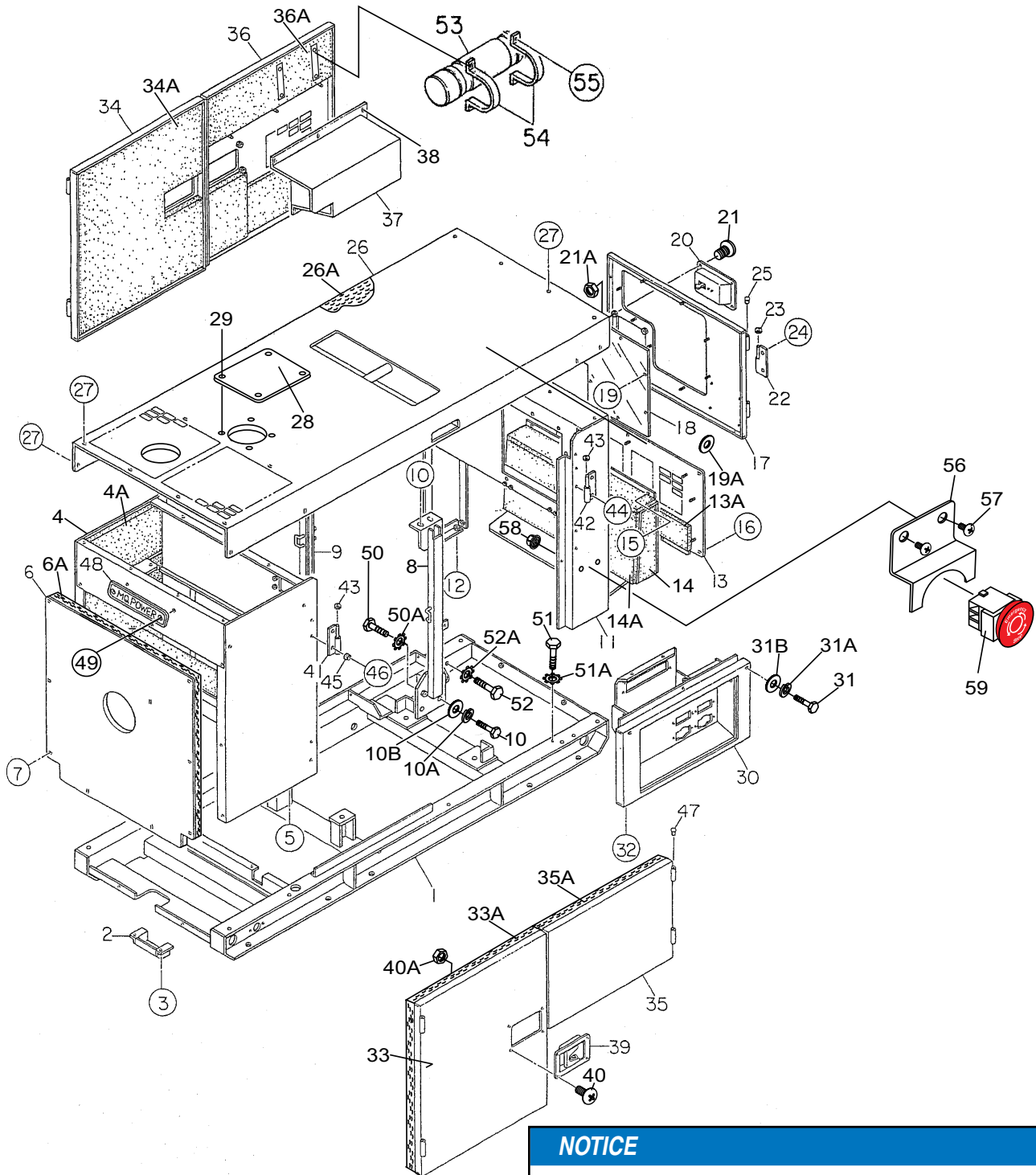

NOTICE

When ordering any painted panel SERVPRO® must add the digit 2 after the part number, this will indicate that the panel color is WHITE.

Once the panel has been received it should be painted Sherwin-Williams (SERVPRO® Green), Product PGS 860083, color Pantone 368C

ENCLOSURE ASSY.

<u>NO.</u>	<u>PART NO.</u>	<u>PART NAME</u>	<u>QTY.</u>	<u>REMARKS</u>
1	M1413003302	BASE	1	
2	M1413400004	UNDER COVER	1	
3	0016908020	HEX HEAD BOLT	2	
4	M1423002302	FRONT FRAME	1	
4A	M1493104903	ACOUSTIC SHEET	1	
5	0016908020	HEX HEAD BOLT	4	
6	M1423200304	FRONT FRAME COVER	1	
6A	M1493100604	ACOUSTIC SHEET	1	
7	0019208020	HEX HEAD BOLT	11	
8	M1433000203	CENTER FRAME	1	
9	M1433000303	CENTER FRAME	1	
10	0010114030	HEX HEAD BOLT	8	
10A	0040014000	WASHER, LOCK	8	
10B	0041214000	WASHER, FLAT	8	
11	M1443001902	REAR FRAME	1	
12	0016908020	HEX HEAD BOLT	4	
13	M1443301803	REAR COVER	1	
14	M1443301703	REAR COVER DUCT	1	
14A	M1493303604	ACOUSTIC SHEET	1	
15	0207006000	HEX NUT	7	
16	0019208020	HEX HEAD BOLT	7	
17	M1443201103	REAR DOOR	1	
18	M1443600114	WINDOW PLATE	1	
19	0037906000	U NUT SELF-LOCKING	8	
19A	0041206000	WASHER, FLAT	8	
20	M9113000002	DOOR HANDLE ASSY.	1	
21	0021806016	MACHINE SCREW	4	
21A	0030006000	HEX HEAD NUT	4	
22	M9110100204	HINGE	2	
23	M9116100004	WASHER	2	
24	0019208020	HEX HEAD BOLT	3	
25	M9310000004	BLIND PLUG	2	
26	M1463002202	ROOF PANEL	1	
26A	M1493502903	ACOUSTIC SHEET	1	
27	0019208020	HEX HEAD BOLT	18	
28	M3310600004	ROOF COVER	1	
29	0019208020	HEX HEAD BOLT	4	
30	M1453201202	SPLASHER PANEL	1	
31	0019108055	HEX HEAD BOLT	2	
31A	0042308000	WASHER, LOCK	2	
31B	0042408000	WASHER, FLAT	2	
32	0016908020	HEX HEAD BOLT	2	

ENCLOSURE ASSY. (CONTINUED)

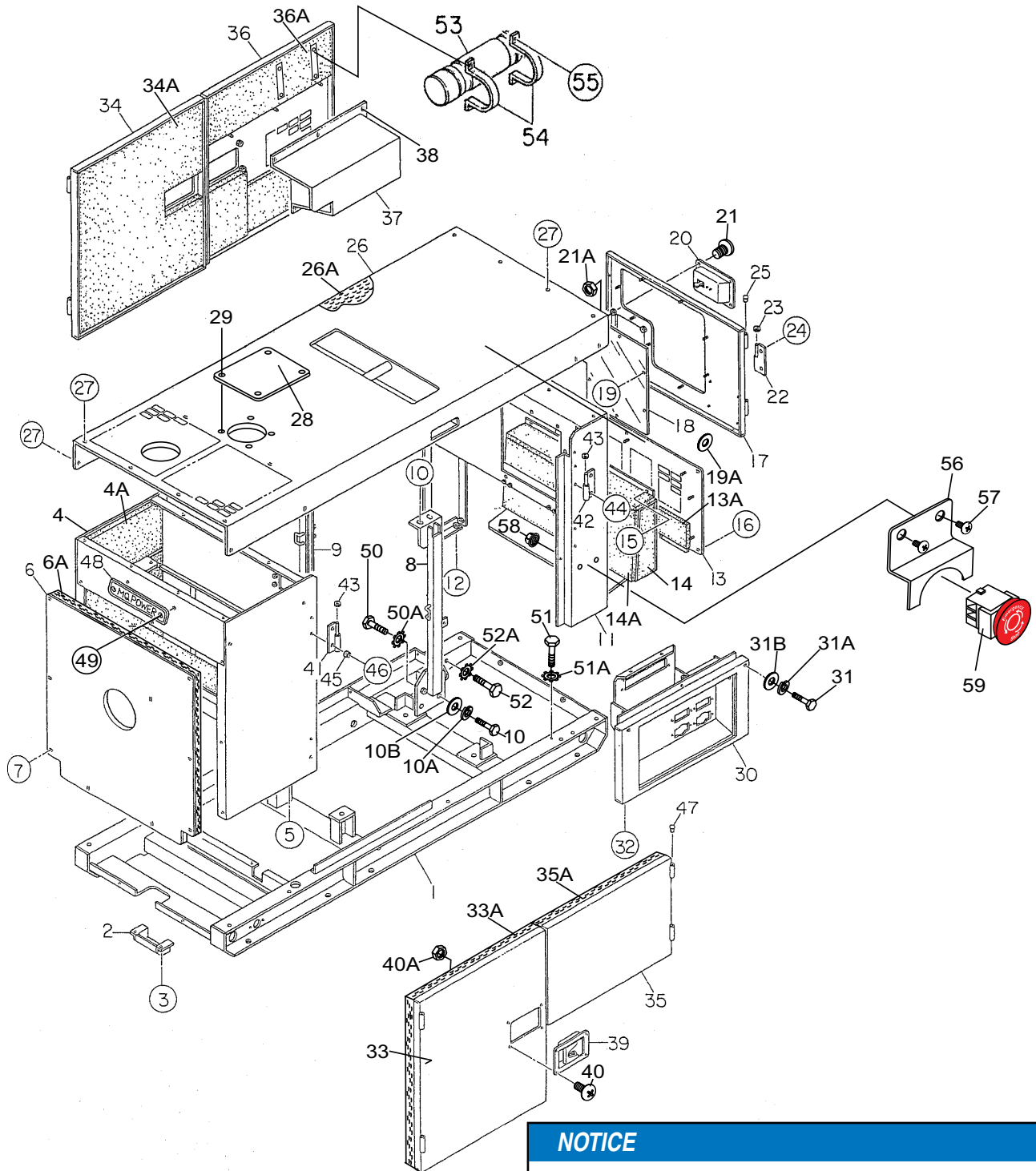

NOTICE

When ordering any painted panel SERVPRO® must add the digit 2 after the part number, this will indicate that the panel color is WHITE.

Once the panel has been received it should be painted Sherwin-Williams (SERVPRO® Green), Product PGS 860083, color Pantone 368C

ENCLOSURE ASSY. (CONTINUED)

<u>NO.</u>	<u>PART NO.</u>	<u>PART NAME</u>	<u>QTY.</u>	<u>REMARKS</u>
33	M1453003803	SIDE DOOR	1	
33A	M1493405604	ACOUSTIC SHEET	1	
34	M1453003903	SIDE DOOR	1	
34A	M1493405704	ACOUSTIC SHEET	1	
35	M1453004003	SIDE DOOR	1	
35A	M1493405804	ACOUSTIC SHEET	1	
36	M1453004703	SIDE DOOR	1	
36A	M1493409404	ACOUSTIC SHEET	1	
37	M1453301403	DUCT	1	
38	0207006000	HEX NUT	6	
39	M9113000002	DOOR HANDLE ASSY.	3	
40	0021806016	MACHINE SCREW	12	
40A	0030006000	HEX HEAD NUT	12	
41	M9110100204	HINGE	4	
42	M9110100304	HINGE	4	
43	M9116100004	WASHER	8	
44	0019208020	HEX HEAD BOLT	9	
45	0601850097	DOOR STOPPER	8	
46	0025408025	MACHINE SCREW	8	
47	M9310000004	BLIND PLUG	8	
48	0600500090	EMBLEM	1	
49	0025106016	MACHINE SCREW	2	
50	0016910020	HEX HEAD BOLT	1	
50A	0040510000	TOOTHED WASHER	1	
51	0016908020	HEX HEAD BOLT	1	
51A	0040508000	TOOTHED WASHER	1	
52	0016906020	HEX HEAD BOLT	1	
52A	0040506000	TOOTHED WASHER	1	
53	0600800321	MANUAL-PAK	1	
54	M1483600804	BOX CLAMPER	2	
55	0016906016	HEX HEAD BOLT	4	
56	EE1687	GUARD, EMERGENCY STOP	1	
57		MACHINE SCREW 10-24X1/2.....	2	OBTAIN LOCALLY
58		NUT, 10-24 (W/ STAR WASHER)	2	OBTAIN LOCALLY
59	EE55989	SWITCH, EMERGENCY STOP	1	

RUBBER SEALS ASSY.

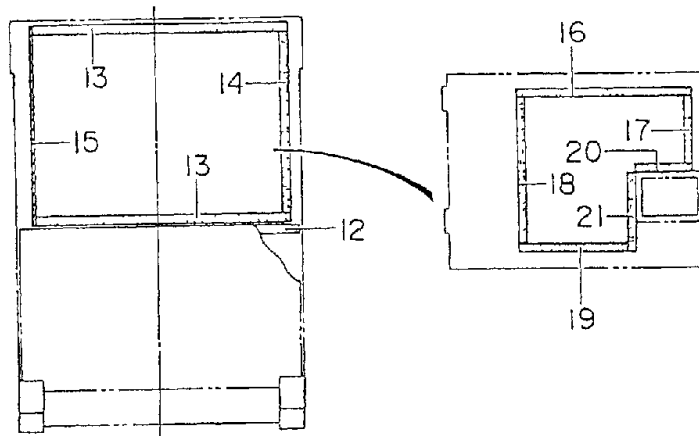
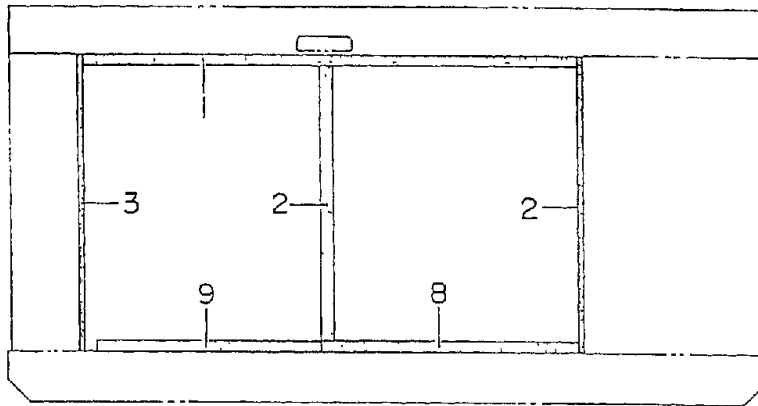
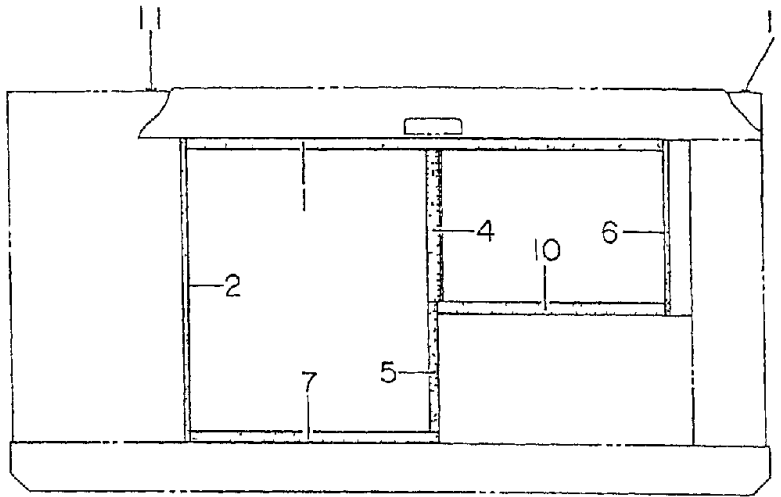

RUBBER SEALS ASSY.

<u>NO.</u>	<u>PART NO.</u>	<u>PART NAME</u>	<u>QTY.</u>	<u>REMARKS</u>
1	0228901150	SEAL RUBBER	2	
2	0228900695	SEAL RUBBER	1	
3	0229400755	SEAL RUBBER	3	
4	M1490300004	SEAL RUBBER	1	
5	0228800325	SEAL RUBBER	1	
6	0229400430	SEAL RUBBER	1	
7	0228900540	SEAL RUBBER	1	
8	0228900550	SEAL RUBBER	1	
9	0229200595	SEAL RUBBER	1	
10	0228900610	SEAL RUBBER	1	
11	0229200750	SEAL RUBBER	2	
12	0229200740	SEAL RUBBER	1	
13	0228800670	SEAL RUBBER	2	
14	0228800525	SEAL RUBBER	1	
15	0228800565	SEAL RUBBER	1	
16	0228100458	SEAL RUBBER	1	
17	0228100171	SEAL RUBBER	1	
18	0228100351	SEAL RUBBER	1	
19	0228100285	SEAL RUBBER	1	
20	0228100153	SEAL RUBBER	1	
21	0228100180	SEAL RUBBER	1	

NAMEPLATE AND DECALS ASSY.

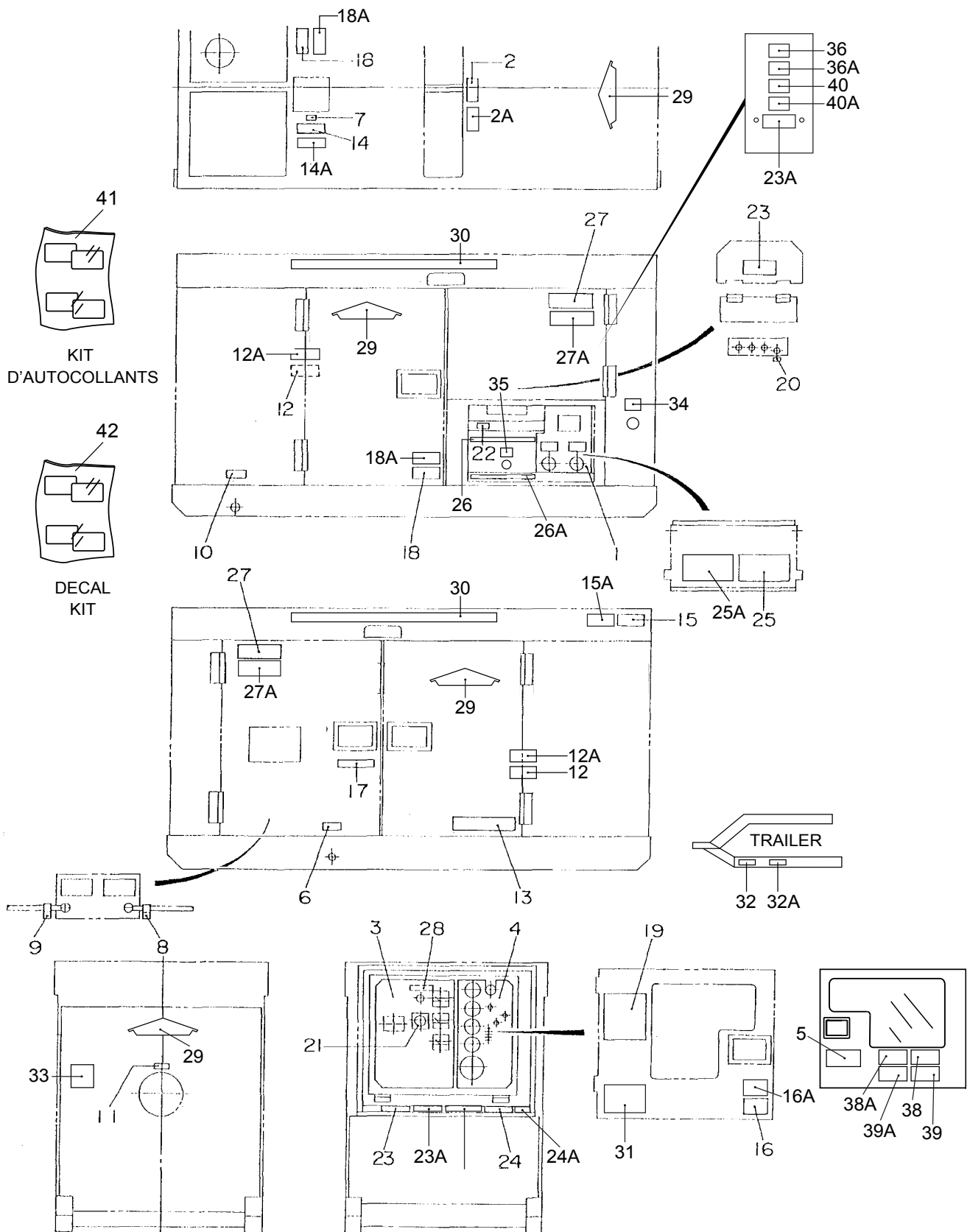

NAMEPLATE AND DECALS ASSY.

NO.	PART NO.	PART NAME	QTY.	REMARKS
1	M1550001803	DECAL; AUXILIARY OUTPUT	1	M15000180
2	M1550001904	DECAL; CAUTION, BAIL MAX CAPACITY (ENGLISH)	1	M15000190
2A#		DECAL; CAUTION, BAIL MAX CAPACITY (FRENCH)	1	
3	M1550003902	DECAL; GENERATOR CONTROL.....	1	M15000390
4	M1550004002	DECAL; ENGINE OPERATING	1	M15000400
5	M1550004103	DECAL; OPERATING PROCEDURES.....	1	M15000410
6	M9500000004	DECAL; OIL DRAIN PLUG.....	1	M90000000
7	M9500100004	DECAL; WATER	1	M90010000
8	M9500300004	DECAL; -	1	M90030000
9	M9500300104	DECAL; +.....	1	M90030010
10	M9500500104	DECAL; FUEL DRAIN PLUG	1	M90050010
11	M9500500304	DECAL; DIESEL FUEL.....	1	M90050030
12	M9503000004	DECAL; WARNING, MOVING PARTS (ENGLISH).....	2	M90300000
12A#		DECAL; WARNING, MOVING PARTS (FRENCH)	2	M90300000CE
13	M9503000103	DECAL; WATER - OIL CHECK.....	1	M90300010
14	M9503100004	DECAL; WARNING, HOT COOLANT (ENGLISH).....	2	M90310000
14A#		DECAL; WARNING, HOT COOLANT (FRENCH)	2	M90310000CE
15	M9503200004	DECAL; WARNING, ENGINE EXHAUST (ENGLISH).....	1	M90320000
15A#		DECAL; WARNING, ENGINE EXHAUST (FRENCH)	1	MQB90420000CE
16	M9503200104	DECAL; DANGER, EXHAUST GAS (ENGLISH).....	1	M90320010
16A#		DECAL; DANGER, EXHAUST GAS (FRENCH).....	1	M90320010CE
17	M9510000104	DECAL; DOCUMENT BOX LOCATED	1	M91000010
18	M9510100004	DECAL; CAUTION HOT PARTS (ENGLISH).....	2	M91010000
18A#		DECAL; CAUTION HOT PARTS (FRENCH)	2	MQB90400030CE
19	M9510200002	DECAL; MQ.....	1	M91020000
20	M9520000004	DECAL; GROUND.....	1	M92000000
21	M9520000104	DECAL; AMMETER CHANGE-OVER SW	1	M92000010
22	M9520000504	DECAL; START CONTACT.....	1	M92000050
23	M9520100004	DECAL; WARNING ELECTRICAL SHOCK HAZ (ENGLISH) .	2	M92010000
23A#		DECAL; WARNING ELECTRICAL SHOCK HAZ (FRENCH) ..	2	MQB9310050CE
24	M9520100304	DECAL; SAFETY INSTRUCTIONS (ENGLISH).....	1	M92010030
24A#		DECAL; SAFETY INSTRUCTIONS (FRENCH)	1	B92110040CE
25	M9520100404	DECAL; DANGER, HIGH VOLTAGE (ENGLISH)	1	M92010040
25A#		DECAL; DANGER, HIGH VOLTAGE (FRENCH)	1	MQS-2731CE
26	M9520100503	DECAL; WARNING, ELECTRICAL (ENGLISH)	1	M92010050
26A#		DECAL; WARNING, ELECTRICAL (FRENCH).....	1	M92010050CE
27	M9520100603	DECAL; CAUTION, START/STOP (ENGLISH).....	2	M92010060
27A#		DECAL; CAUTION, START/STOP (FRENCH)	2	MQC92210000CE
28	M9521000004	DECAL; TERMINAL	1	
29	51454	DECAL; SERVPRO 14" REFLECTIVE LOGO	4	
30	51817	DECAL; "LIKE IT NEVER HAPPENED"	2	
31		DECAL; SERIAL PLATE, EPA EVAP	1	CONTACT MQ PARTS
32	49002	DECAL; WARNING TRAILER (ENGLISH)	1	
32A#		DECAL; WARNING, TRAILER (FRENCH)	1	490002CE
33	EE52343	DECAL, FUELING INSTRUCTIONS	1	
34	M050911	E-STOP DECAL	1	
35	EE52049	DECAL; BATT CHGER/WATER HEATER AC120V INPUT	1	

NAMEPLATE AND DECALS ASSY.

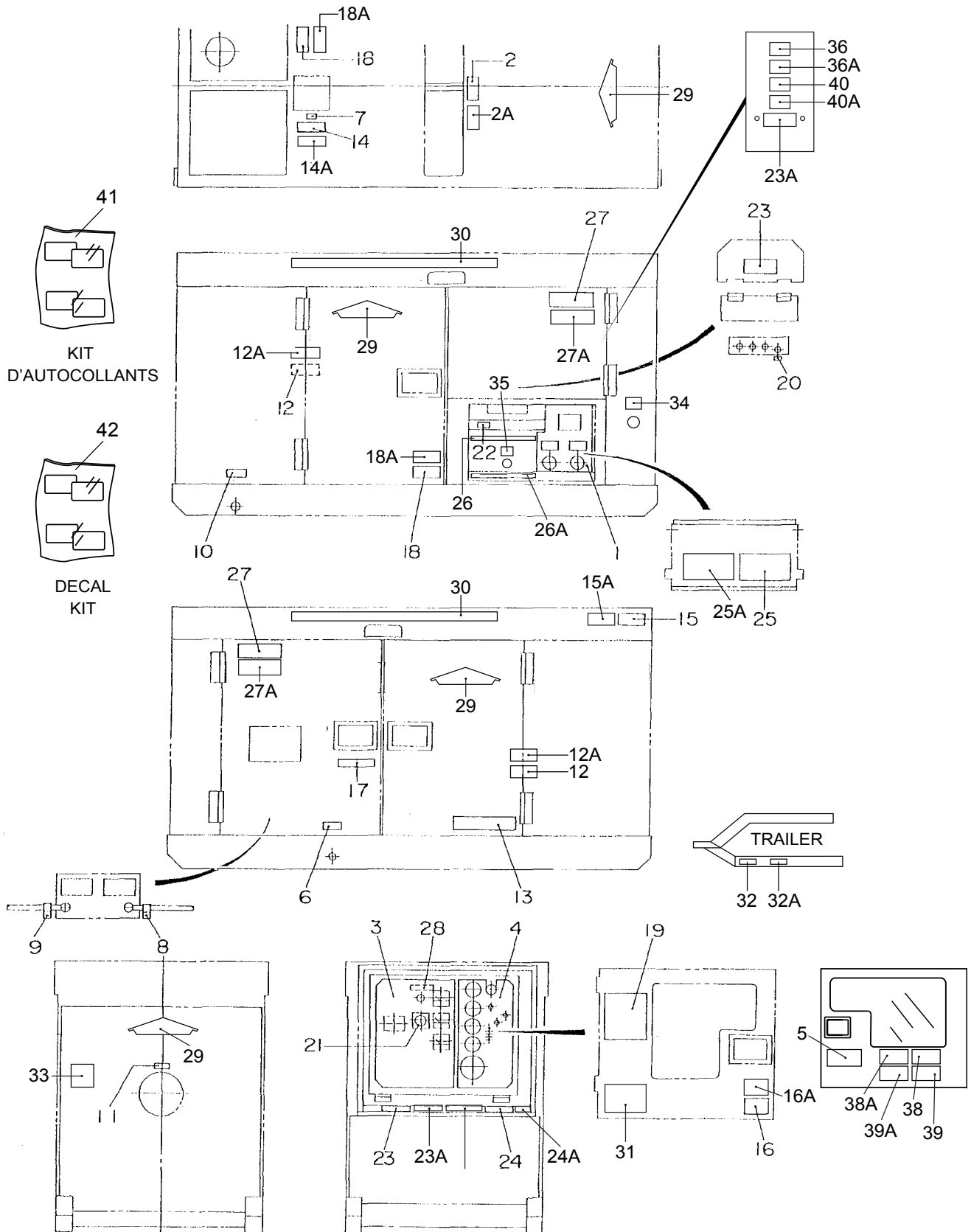

NAMEPLATE AND DECALS ASSY.

<u>NO.</u>	<u>PART NO.</u>	<u>PART NAME</u>	<u>QTY.</u>	<u>REMARKS</u>
36\$	EE57072	DECAL: NOTICE, BONDED TO FRAME (ENGLISH)	2	
36A\$	EE57073	DECAL: NOTICE, BONDED TO FRAME (FRENCH)	2	
38\$	EE57077	DECAL: NOTICE, CLASS H (ENGLISH)	1	
38A\$	EE57078	DECAL: NOTICE, CLASS H (FRENCH)	1	
39\$	EE57070	DECAL: NOTICE, OVERLOAD (ENGLISH)	1	
39A\$	EE57071	DECAL: NOTICE, OVERLOAD (FRENCH)	1	
40\$	EE57079	DECAL: NOTICE, SUPPLY WIRES (ENGLISH)	1	
40A\$	EE57080	DECAL: NOTICE, SUPPLY WIRES (FRENCH)	1	
41	EE52650	DECAL KIT (FRENCH).....	1.....	INCLUDESITEMSW/#
42	EE57074	DECAL KIT (ENGLISH & FRENCH)	1.....	INCLUDESITEMSW/\$

TERMS AND CONDITIONS OF SALE — PARTS

PAYMENT TERMS

Terms of payment for parts are net 30 days.

FREIGHT POLICY

All parts orders will be shipped collect or prepaid with the charges added to the invoice. All shipments are F.O.B. point of origin. Multiquip's responsibility ceases when a signed manifest has been obtained from the carrier, and any claim for shortage or damage must be settled between the consignee and the carrier.

MINIMUM ORDER

The minimum charge for orders from Multiquip is \$15.00 net. Customers will be asked for instructions regarding handling of orders not meeting this requirement.

RETURNED GOODS POLICY

Return shipments will be accepted and credit will be allowed, subject to the following provisions:

1. A Returned Material Authorization must be approved by Multiquip prior to shipment.
2. To obtain a Return Material Authorization, a list must be provided to Multiquip Parts Sales that defines item numbers, quantities, and descriptions of the items to be returned.
 - a. The parts numbers and descriptions must match the current parts price list.
 - b. The list must be typed or computer generated.
 - c. The list must state the reason(s) for the return.
 - d. The list must reference the sales order(s) or invoice(s) under which the items were originally purchased.
 - e. The list must include the name and phone number of the person requesting the RMA.
3. A copy of the Return Material Authorization must accompany the return shipment.
4. Freight is at the sender's expense. All parts must be returned freight prepaid to Multiquip's designated receiving point.

5. Parts must be in new and resalable condition, in the original Multiquip package (if any), and with Multiquip part numbers clearly marked.
6. The following items are not returnable:
 - a. Obsolete parts. (If an item is in the price book and shows as being replaced by another item, it is obsolete.)
 - b. Any parts with a limited shelf life (such as gaskets, seals, "O" rings, and other rubber parts) that were purchased more than six months prior to the return date.
 - c. Any line item with an extended dealer net price of less than \$5.00.
 - d. Special order items.
 - e. Electrical components.
 - f. Paint, chemicals, and lubricants.
 - g. Decals and paper products.
 - h. Items purchased in kits.
7. The sender will be notified of any material received that is not acceptable.
8. Such material will be held for five working days from notification, pending instructions. If a reply is not received within five days, the material will be returned to the sender at his expense.
9. Credit on returned parts will be issued at dealer net price at time of the original purchase, less a 15% restocking charge.
10. In cases where an item is accepted, for which the original purchase document can not be determined, the price will be based on the list price that was effective twelve months prior to the RMA date.
11. Credit issued will be applied to future purchases only.

PRICING AND REBATES

Prices are subject to change without prior notice. Price changes are effective on a specific date and all orders received on or after that date will be billed at the revised price. Rebates for price declines and added charges for price increases will not be made for stock on hand at the time of any price change.

Multiquip reserves the right to quote and sell direct to Government agencies, and to Original Equipment Manufacturer accounts who use our products as integral parts of their own products.

SPECIAL EXPEDITING SERVICE

A \$35.00 surcharge will be added to the invoice for special handling including bus shipments, insured parcel post or in cases where Multiquip must personally deliver the parts to the carrier.

LIMITATIONS OF SELLER'S LIABILITY

Multiquip shall not be liable hereunder for damages in excess of the purchase price of the item with respect to which damages are claimed, and in no event shall Multiquip be liable for loss of profit or good will or for any other special, consequential or incidental damages.

LIMITATION OF WARRANTIES

No warranties, express or implied, are made in connection with the sale of parts or trade accessories nor as to any engine not manufactured by Multiquip. Such warranties made in connection with the sale of new, complete units are made exclusively by a statement of warranty packaged with such units, and Multiquip neither assumes nor authorizes any person to assume for it any other obligation or liability whatever in connection with the sale of its products. Apart from such written statement of warranty, there are no warranties, express, implied or statutory, which extend beyond the description of the products on the face hereof.

Effective: February 22, 2006

To process a warranty or repair claim, **click** the "Return, Warranty, and Order Shortage Request" icon on the ServoNET® home page. You also may contact the SERVPRO® RMA Department by phone 866-885-6833 or via email at rma@servpronet.com.

To expedite the warranty claim process, please have the following:

- Equipment model number
- Serial number.
- Usage hours (if applicable).

As part of the Servpro® Industries, Inc. RMA/Warranty program, when Franchises purchase equipment from Servpro® Industries, Inc. unit date of purchase and serial numbers are recorded on the invoice.

Servpro® Industries, Inc. maintains proof of purchase and equipment warranty records in their database. This eliminates the frustration of digging through stacks of paperwork to determine warranty coverage for equipment.

After receipt of the completed Warranty/RMA Request form, an RMA coordinator will check warranty status on any listed equipment prior to submitting the claim information to the vendors (s),

If the equipment is not covered under warranty, the vendor (s) will provide a competitive repair estimate prior to completing any non-warranty repairs. The RMA Coordinator will present repair options and receive Franchise approval prior to authorizing non-warranty repairs.

If the unit is covered under warranty, the RMA Coordinator will communicate the repair and return process.

Servpro® RMA Department is here to serve you!

OPERATION AND PARTS MANUAL



SERVPRO® INDUSTRIES INC.
801 Industrial Blvd.
Gallatin, TN 37066
Phone: 615-451-0200