

FCC ID : YDTMTM17LP

FCC Statement:

This equipment has been tested and found to comply with the limits for Part 15 of the FCC rules. These limits are designed to provide reasonable protection against harmful interference in a residential installation.

This equipment generates, uses and can radiate radio frequency energy and, if not installed and used in accordance with the instructions, may cause harmful interference to radio communications.

However, there is no guarantee that interference will not occur in a particular installation. If this equipment does cause harmful interference to radio or television reception, which can be determined by turning the equipment off and on, the user is encouraged to try to correct the interference by one or more of the following measures:

- Reorient or relocate the receiving antenna.
- Increase the separation between the equipment and receiver.
- Connect the equipment to an outlet on a circuit different from that to which the receiver is connected.

This device complies with part 15 of the FCC rules. Operation is subject to the following two conditions:

- (1) This device may not cause harmful interference, and
- (2) this device must accept any interference received, including interference that may cause undesired operation.

Note: Modifications to this product will void the user's authority to operate this equipment.



Manufactured By : Mun Ah Plastic Electronic Toys Company.,Ltd

CTX-1710 2.4GHz Transmitter

Power ON / OFF the Transmitter

The Transmitter CTX-1710

Steering Wheel : Control direction (Left/Right) of the RC model.
Throttle Trigger : Control speed and direction (Forward/Brake/Backward) of the driving model.

Antenna : Transmit signal to the model.

Power ON / OFF : Power ON / OFF the transmitter

SYNC & Battery Indicator : Top Green LED light indicates synchronization status and/or adequate battery power supply.

Power Indicator : Bottom Red LED light indicates power "ON".

Dual Rate Dial : Adjust the same maximum steering angle on both sides when model turns Left / Right

ST. Trim Dial : Adjust the neutral position of steering servo when model wheels are straight ahead.

TH. Trim Dial : Make sure the model stays still when releasing the throttle trigger.

Battery Compartment Tray : Cover and hold the batteries powering the transmitter.

* In general, user will experience under steer when making a wide turn at high speed or over steer when making sharp turn at high speed (easy to spin out). User should practice the throttle and steering approach for different cornering at different speed or road surface.

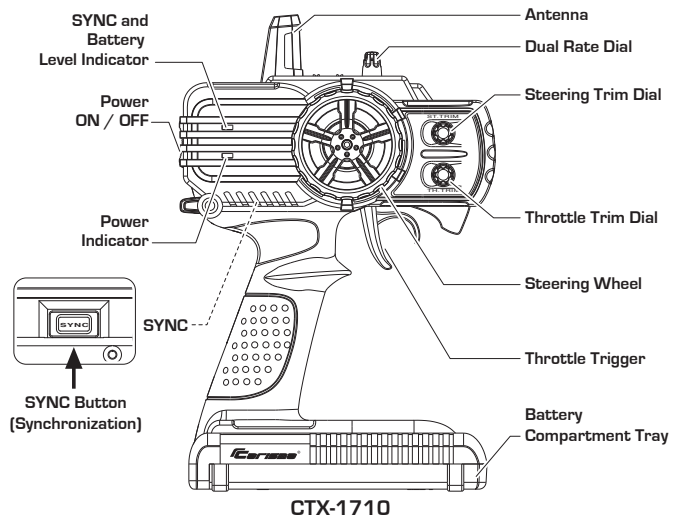

Battery Installation

Supplied with 4 x 1.5V AA Batteries, CTX-1710 can be operated a few hours. Installation: Remove the battery compartment cover as shown below.

Install the batteries observing the polarity marked on battery compartment.

Then reinstall the battery compartment cover as the Picture shown below.

Warning :

Never disassemble batteries or put the batteries in fire, chemical agents, otherwise they may cause personal injuries or property damages.

Battery Disposal :

Observe corresponding regulations about wasted battery treatment regulations.

1. After running out of power, dispose of wasted batteries in designated areas far away from water supply, household areas and planted areas.
2. Submit the wasted batteries to specific recycling stations.

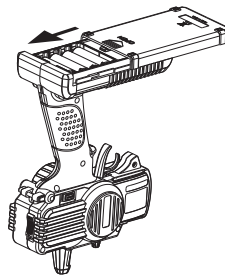
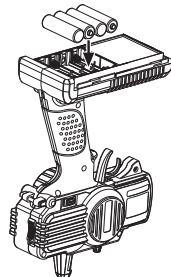
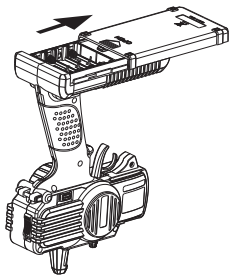

Battery LED Indicator

The Green LED indicator located on the front left side of the transmitter indicates the power supply of batteries. The green LED will go solid on indicating that the batteries have sufficient power. When batteries voltage drops below 4 volts, the Green LED will flash, indicating the batteries power is low and should be replaced.

Solid Green :
Sufficient Power supply

Flashing :
Time to replace batteries

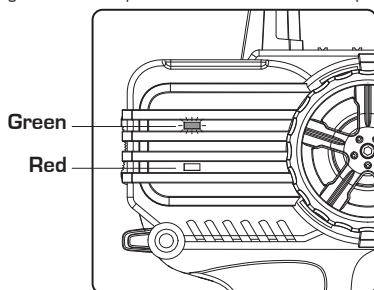

Pre-Run Check

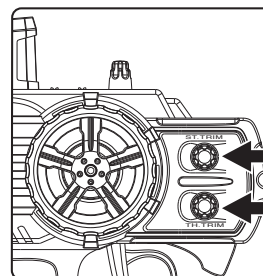

1. Steering : Adjust the steering trim to keep the front wheels in straight line when steering wheel remains in NEUTRAL position.
2. Throttle : Adjust the throttle trim to ensure the rear wheels stop rotating when throttle trigger remains in NEUTRAL position.

* Always turn on the transmitter first by sliding the switch on the left side from bottom to top. The small red and green lights above the switch should both light up. If not, you need to check for low or incorrectly installed batteries.

Top Control Panel

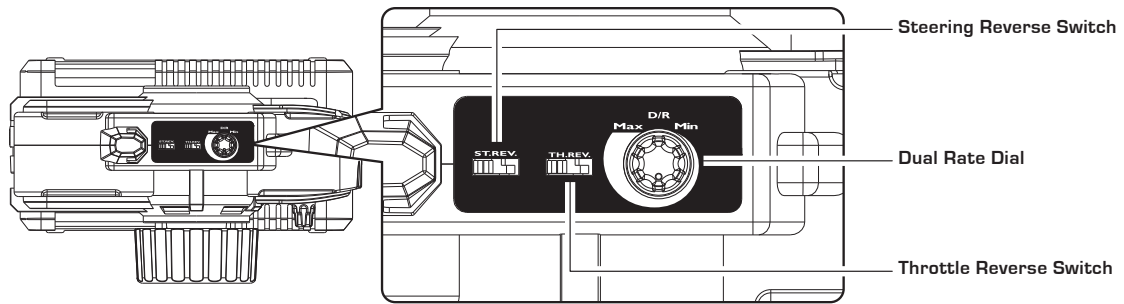

Dual Rate Dial

Dual Rate Dial enables to adjust the same maximum steering angle of servo on both sides (Left and Right) when model makes steering. The Dual Rate Dial affects the sensitivity of servo. Reducing dual rate value can lower the sensitivity of servo and reduce the same maximum steering angle on both sides. Remember to adjust the dual rate value within the adjustment range.

Reversing

Reversing is used to change the response direction of steering wheel and throttle trigger. CTX-1710 Transmitter features 2 reversing functions: Steering Reverse and Throttle Reverse.

Steering Reverse: Reverse the response direction when operating steering wheel. Turning left steering wheel, the model turns right while turning right the model turns left.

Throttle Reverse: Reverse the response direction when operating throttle trigger. Pushing forward throttle trigger the model moves backward while pulling back, the model moves forward. If necessary you can just use a small screwdriver to adjust the corresponding switches.

Trimming

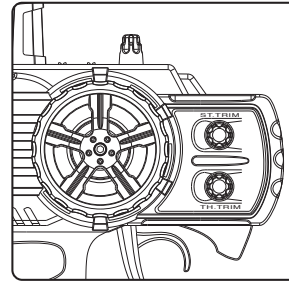

CTX-1710 features two trimming functions:

Steering Trim and Throttle Trim.

Steering Trim Dial :

Adjust the neutral position of steering servo when the wheels are straight ahead. Normally steering trim is adjusted until the model can keep straight tracks.

Throttle Trim Dial :

Adjust neutral position of throttle servo. Make sure the model stays still when releasing the throttle trigger.