

SAFETY PRECAUTIONS



SAFETY PRECAUTIONS

THIS MODEL IS ONLY SUITABLE FOR PEOPLE 14 YEARS OLD AND UP.

THIS RADIO CONTROL MODEL IS NOT A TOY.

Beginner should seek advice from experienced person in order to assemble the model or parts correctly and to make best performance.

* Assemble this model or parts only in place out of children's reach, and take safe precautions before operating this model. User is fully responsible for the model assembly and safe operations.

Introduction

This is a sophisticated hobby product and not a toy. It must be operated with caution and common sense. User also requires some basic mechanical abilities. Fail to operate this product in a safe and responsible manner could result in injury or do damage to the product or other properties. This product is not intended for use by children without direct adult supervision. The product manual contains instructions for safe operation and maintenance. It is essential to read and follow all the instructions and warnings in the manual prior to assembly, setup or use, in order to operate correctly and avoid damage or injury.

Safety, Precautions, and Warnings

As the user of this product, you are solely responsible for operating it in a manner that does not endanger yourself and others or result in damage to the product or the property of others.

This model is controlled by a radio signal that is subject to interference from many sources outside your control. This interference can cause momentary loss of control so it is necessary to always keep a safe distance in all directions around your model, as this will help to avoid collisions or injury.

- Always operate your model in an open area away from cars, traffic, or people.
- Avoid operating your model on the street where injury or damage can occur.
- Never operate the model out into the street or populated areas for any reason.
- Never operate your model with low transmitter batteries.
- Carefully follow the directions and warnings for this product and any optional support equipments (chargers, rechargeable battery packs, etc.) that you use.
- Keep all chemicals, small parts and anything electrical out of the reach of children.
- Moisture causes damage to electronics. Avoid water exposure to all equipments not specifically designed and protected for this purpose.

CE Compliance Information For The European Union

The associated regulatory agencies of the following countries recognize the noted certifications for this product as authorized for sale and use.

| | | | | | | | | | | | | |
|----|----|----|----|----|----|----|----|----|----|----|----|----|
| UK | DE | DK | BG | SE | CZ | ES | NL | SK | HU | RO | FR | PT |
| FI | EE | LV | LT | PL | AT | CY | SI | GR | MT | IT | IE | LU |

Declaration of Conformity

Products: Carisma CTX-2710 2.4GHz Transmitter, MRX2800 Receiver

Equipment Class: 2

The objects of declaration described above are in conformity with the requirements of the specifications listed below.

Item Name : Carisma CTX-2710 2.4GHz Transmitter and MRX2800 Receiver

ETSI EN 300 328 V1.7.1:2006

ETSI EN 301 489-1 V1.8.1:2008

EN 301 489-17 V2.1.1:2009

EN 50371:2002

Directive 1999/5/EC (R&TTE)

Article 3.1a Health

Article 3.1b EMC

Article 3.2 Radio Spectrum

FCC ID YDTMTM27HP

Statement - This device complies with Part 15 of the FCC Rules.

Operation is subject to the following two conditions:

- (1) this device may not cause harmful interference, and
- (2) this device must accept any interference received, including interference that may cause undesired operation.

Changes or modifications not expressly approved by the party responsible for compliance could void the user's authority to operate the equipment.

RF Exposure Warning:

This equipment complies with FCC radiation exposure limits set forth for an uncontrolled environment.

And should be operated with minimum distance of 20 cm between the antenna & your body.

CE 0197



Manufactured By : Mun Ah Plastic Electronic Toys Company.,Ltd

Carisma CTX-2710 2.4GHz FHSS Technology System

The following is an overview of the various functions and adjustments found on CTX-2710 radio system for Carisma models. It is important to read and understand about all of these functions and adjustments before driving.

Power ON / OFF the Transmitter

The Transmitter CTX-2710

Steering Wheel : Control direction (Left / Right) of the RC model.
Throttle Trigger : Control speed and direction (Forward/Brake/Backward) of the driving model.

Antenna : Transmit signal to the model.

Power ON / OFF : Power ON / OFF the transmitter

SYNC & Battery Indicator : Top Green LED light indicates synchronization status and/or adequate battery power supply.

Power Indicator : Bottom Red LED light indicates power "ON".

Dual Rate Dial : Adjust the same maximum steering angle on both sides when model turns Left / Right

ST. Trim Dial : Adjust the neutral position of steering servo when model wheels are straight ahead.

TH. Trim Dial : Make sure the model stays still when releasing the throttle trigger.

Battery Compartment Tray : Cover and hold the batteries powering the transmitter.

* In general, user will experience under steer when making a wide turn at high speed or over steer when making sharp turn at high speed (easy to spin out). User should practice the throttle and steering approach for different cornering at different speed or road surface.

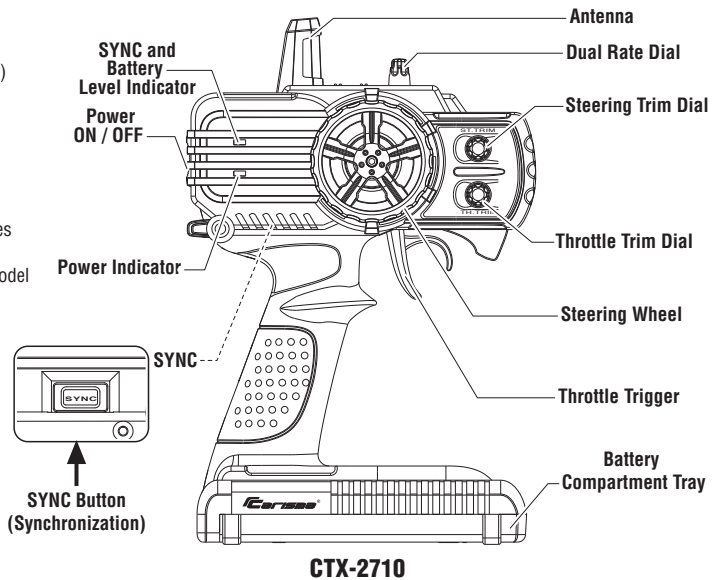

Battery Installation

Supplied with 4 x 1.5V AA Batteries, CTX-2710 can be operated a few hours. Installation: Remove the battery compartment cover as shown below.

Install the batteries observing the polarity marked on battery compartment.

Then reinstall the battery compartment cover as the Picture shown below.

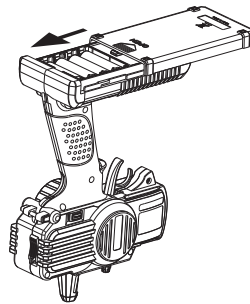
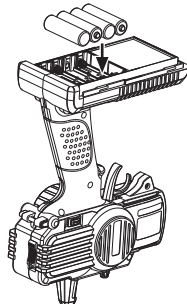
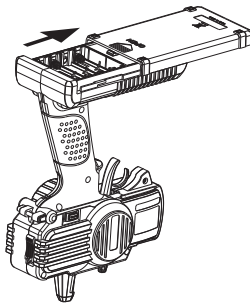

Warning : Never disassemble batteries or put the batteries in fire, chemical agents, otherwise they may cause personal injuries or property damages.

Battery Disposal : Observe corresponding regulations about wasted battery treatment regulations.

1. After running out of power, dispose of wasted batteries in designated areas far away from water supply, household areas and planted areas.
2. Submit the wasted batteries to specific recycling stations.

Battery LED Indicator

The Green LED indicator located on the front left side of the transmitter indicates the power supply of batteries. The green LED will go solid on indicating that the batteries have sufficient power. When batteries voltage drops below 4 volts, the Green LED will flash, indicating the batteries power is low and should be replaced.

Solid Green : Sufficient Power supply

Flashing : Time to replace batteries

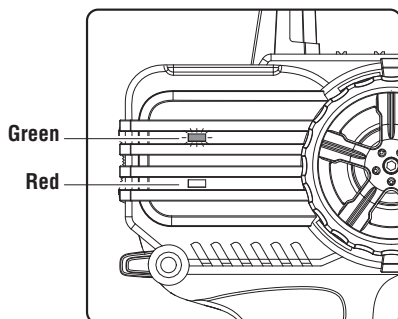

Pre-Run Check

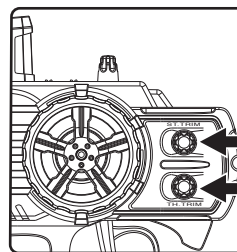

1. Steering : Adjust the steering trim to keep the front wheels in straight line when steering wheel remains in NEUTRAL position.
2. Throttle : Adjust the throttle trim to ensure the rear wheels stop rotating when throttle trigger remains in NEUTRAL position.

* Always turn on the transmitter first by sliding the switch on the left side from bottom to top. The small red and green lights above the switch should both light up. If not, you need to check for low or incorrectly installed batteries.

For Transmitter



Heavy Duty
1.5V "AA" Size Batteries



Instructions for Disposal of WEEE by Users in the European Union

This product must never be thrown away with other waste. Thus the users are liable for disposing the wasted model by submitting them to designated collection stations specific for recycling electronic and electric items. Disposing of the wasted model in this way is helpful to conserve natural resources and enable to keep human health and protect the environment. For more information about wasted model disposal and recycling, please contact your local city office, your disposal service or where you purchased the product.

ABOUT THE RADIO SYSTEM

Top Control Panel

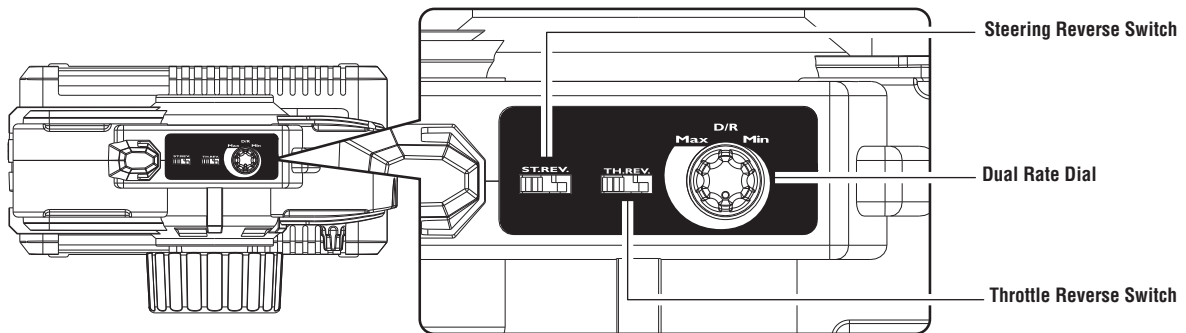

Dual Rate Dial

Dual Rate Dial enables to adjust the same maximum steering angle of servo on both sides (Left and Right) when model makes steering. The Dual Rate Dial affects the sensitivity of servo. Reducing dual rate value can lower the sensitivity of servo and reduce the same maximum steering angle on both sides. Remember to adjust the dual rate value within the adjustment range.

Reversing

Reversing is used to change the response direction of steering wheel and throttle trigger. CTX-2710 Transmitter features 2 reversing functions: Steering Reverse and Throttle Reverse.

Steering Reverse: Reverse the response direction when operating steering wheel. Turning left steering wheel, the model turns right while turning right the model turns left.

Throttle Reverse: Reverse the response direction when operating throttle trigger. Pushing forward throttle trigger the model moves backward while pulling back, the model moves forward. If necessary you can just use a small screwdriver to adjust the corresponding switches.

Trimming

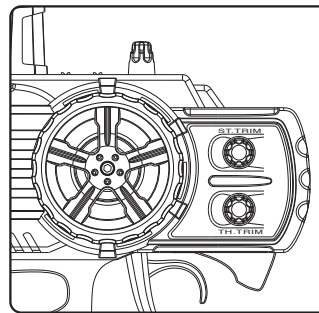

CTX-2710 features two trimming functions: Steering Trim and Throttle Trim.

Steering Trim Dial :

Adjust the neutral position of steering servo when the wheels are straight ahead. Normally steering trim is adjusted until the model can keep straight tracks.

Throttle Trim Dial :

Adjust neutral position of throttle servo. Make sure the model stays still when releasing the throttle trigger.

RECEIVER CONNECTION AND INSTALLATION

Carisma 2.4GHz Receiver MRX2800

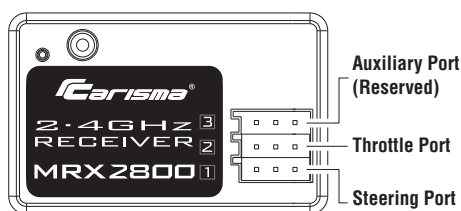

Auxiliary Port (Reserved)

Steering Port : Where to plug in the servos.

Throttle Port : Where to plug in the Electronic Speed Controller (ESC).

Setup button : Synchronize transmitter and receiver. Select frame rate.

Tips :

- Wrap the receiver with something soft, such as foam rubber, to avoid vibration. If there is a chance of getting wet, put the receiver in a waterproof bag or balloon.

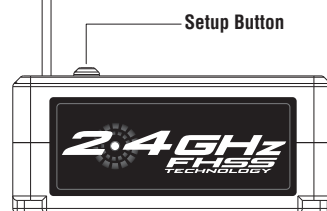

Warning :

- Never bend the metal pins on the PCB of receiver.
- Never cut the antenna cable.
- Install the antenna vertically as shown in the figure.
- Keep the antenna as far away from the motor, ESC and other noise sources as you possibly can.

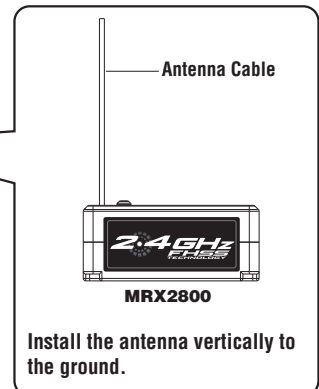

Remarks :

The mounting positions of receiver and antenna cable greatly affect the operating range.

Synchronization & Frame Rate Adjust

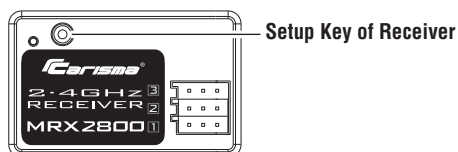

1. Prior to any operation make sure the transmitter and receiver are both turned off.
2. Press and hold the setup button on the receiver while power on the receiver.
3. Release the setup button till green LED flashes.
4. Press the setup button to select the frame rate with green LED flashing.
Faster Flashing = High frame rate (7ms) for digital servo
Slower Flashing = Low frame rate (15ms) for analogue servo
5. Power on the transmitter. With the transmitter steering wheel and throttle trigger in neutral position (full stop and straight steering), press the SYNC button of the transmitter.
6. When synchronization is done, the green LED on both receiver and transmitter will turn solid on.

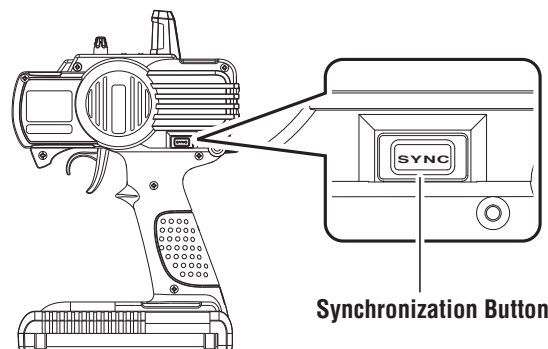

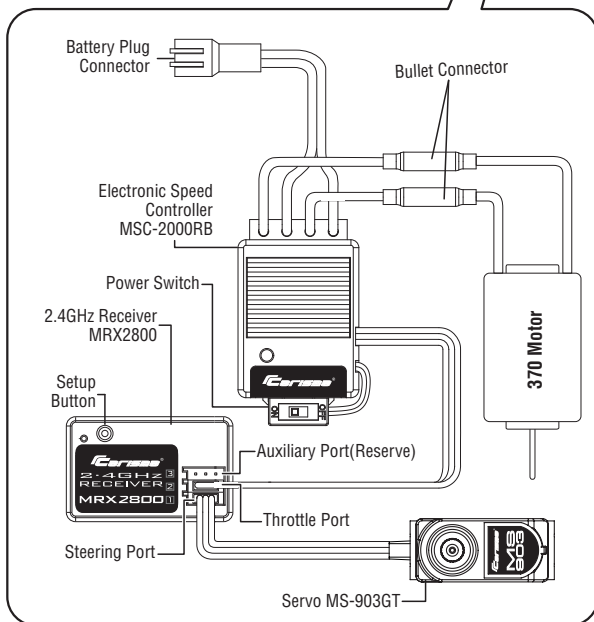
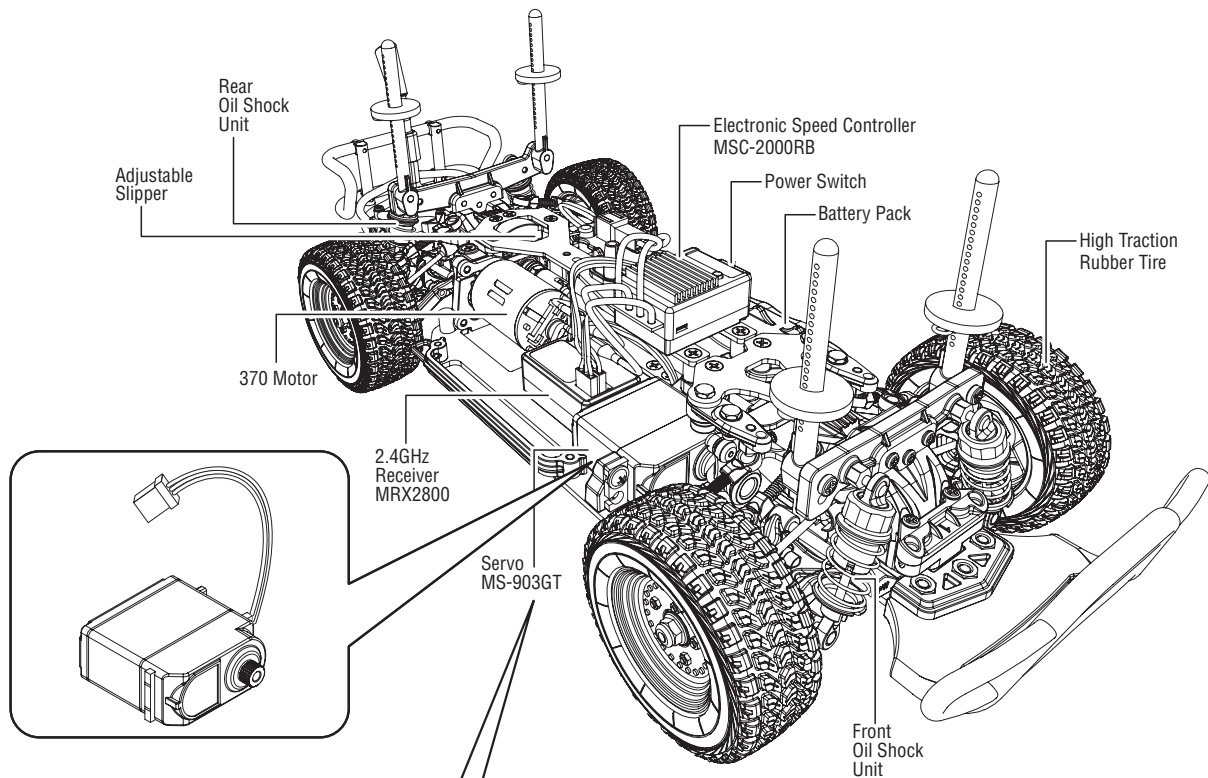

WARNING :
Do not modify connector plug or motor connector otherwise may cause possible damage to MSC-2000RB ESC due to improper use!
Do not run the model in rainy day or under terrible weather.

ESC MSC-2000RB Features

Battery Selection:

When ESC power on, LED will be flashing for 2 seconds to indicate the Selected Battery Type. During LED flashing, user can press the key to select the other battery type. After key pressed, LED will be flashing 2 more seconds.

1. Turn on ESC and push button once within 2 seconds, push again to select between LiPo (7.4V) / NiMH (7.2V) .
2. Red light will be LiPo.
3. Green light will be NiMH.

Under Voltage Protection (NiMH / LiPo) :

User can select either 6V cutoff for LiPo or 4V cutoff for NiMH. When input voltage is under the set cut off limit, ESC will shut off power output automatically and protect battery effectively.

One touch End-Points Setup:

- Step 1 - Turn on the transmitter, throttle at neutral (stop) position.
- Step 2 - Hold the setup button on the ESC and switch on, the Red & Green LED will light up, then release the setup button.
- Step 3 - Green LED will flash, then hold the throttle to maximum forward position until the Green LED becomes Solid on.
- Step 4 - Wait until Red LED flashes, then hold the throttle to the maximum Reverse position until the Red LED becomes Solid on.
- Step 5 - Gently release the throttle to neutral (stop) position.

ESC Mode Selection:

During normal operation, the GREEN LED is used to indicate the ESC mode in stop position as following:

- Forward / Reverse Mode & Smart Brake Mode - GREEN LED solid on
- Forward Only Mode - GREEN LED fast flashing

Over Heat Protection:

When the ESC temperature is over the safety limit, ESC will shut off power output automatically, meanwhile, Red & Green LED will flash alternatively for 30 secs. After 30 secs, ESC normal function will be resumed.

Over Load Protection:

When motor is stalled, ESC will shut off power output automatically, meanwhile, Red LED will be flashing for 30 secs. After 30 secs, ESC will back to normal.

STEERING AND RATE ADJUSTMENT

Control of the R/C Model

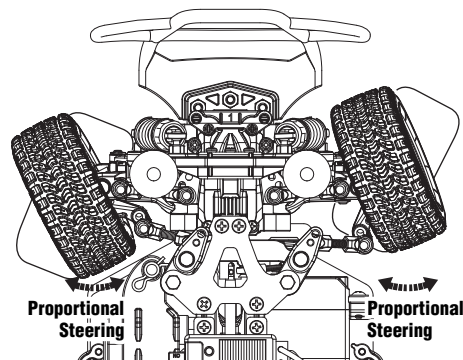
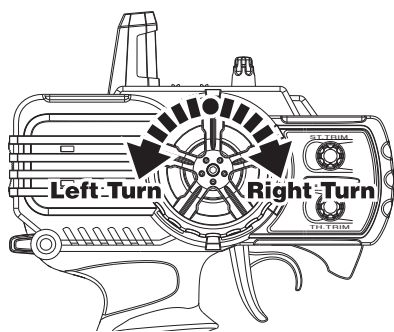

Steering Rate

Your transmitter is equipped with a steering rate control on the top of the transmitter just above the steering wheel. This advanced feature, usually found only on competition-type transmitter, allows you to adjust the amount the front tires move when you turn the steering wheel. This is really helpful when you are on slick, as well as high traction, surfaces. If your Carisma model turns too sharply and / or spins out easily, try turning the steering rate down by rotating the knob counterclockwise (to the left). For sharper or additional steering, turn the knob clockwise (to the right).

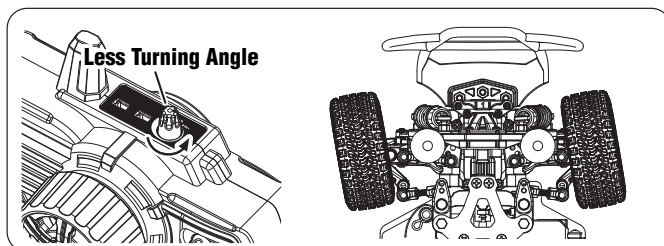
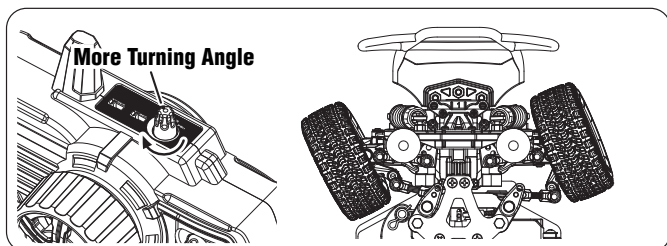

Throttle Trigger

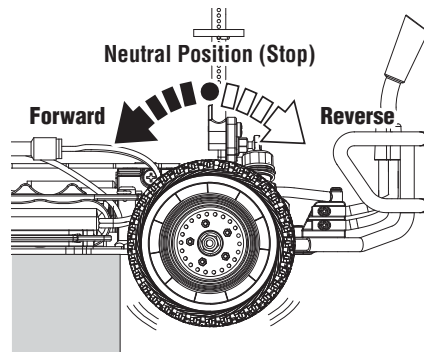
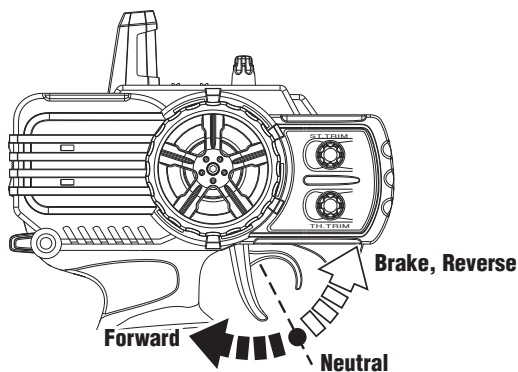

To reverse, push the throttle trigger to the braking position. After the car has come to a stop, release the throttle trigger and pull the trigger again to go reverse.

Once power on the Carisma model Car, turn on the transmitter by sliding the switch to "On" position. If the wheels turn, adjust the "TH Trim" knob located on the lower right of the steering wheel until they stop. To go forward, pull the trigger back. If you need reverse, wait for the model to stop then push the trigger forward. When going forward, the model should move in a straight line. If not, adjust the "ST Trim" so that it tracks in a straight line without having to move the steering wheel.

After you have finished, turn the Carisma model Car off first by sliding the switch on the ESC to the " OFF" position. After the model has been turned off, turn off the transmitter.

If you wish to clean your Carisma model Car, use compressed air and / or a soft paint brush to remove the dust and dirt. Never use chemicals or anything wet as it can cause damage to both the electronics and plastic parts.

Always

- Take caution when running your vehicle near people
- Turn both the Carisma model car and the Transmitter "OFF" when done
- Check the battery condition of the transmitter before running

Never

- Operate the Carisma model Car with low battery power
- Run the Carisma model Car through water
- Use chemicals to clean the chassis