

# CHALLENGE MODEL EH-3C PAPER DRILL

Instruction Manual  
SN#975459 & Up



Provided By

**MyBinding**.com®  
*When Image Matters.*

SERIAL NO-

MODEL-

### SAFETY ALERT



This safety alert symbol means CAUTION OR WARNING-PERSONAL SAFETY INSTRUCTION. Personal injury may result if safety precautions are not carefully read before attempting to operate or repair this machine. See SAFETY PRECAUTIONS, page 4.

- This machine is designed for **ONE PERSON OPERATION ONLY!**
- Always **DISCONNECT THE POWER** before working on this machine.
- **DO NOT OPERATE WITH ANY GUARDS REMOVED!** Replace all guards before operating.
- **CRUSH HAZARD** - Keep hands, hair, cleaning rags, & loose clothing away from drills.

# Instruction and Parts Manual



## MODEL EH-3C Paper Drilling Machine

**This manual covers serial numbers 975459 & up.  
ALWAYS GIVE THE SERIAL NUMBER OF YOUR MACHINE WHEN WRITING.**

*Sold and serviced by*

**THE CHALLENGE MACHINERY COMPANY**

1433 Fulton Avenue/Grand Haven, Michigan 49417-1594 U.S.A.  
Phone: 616/842-8300 • Fax: 616/842-6511 • [www.challengemachinery.com](http://www.challengemachinery.com)

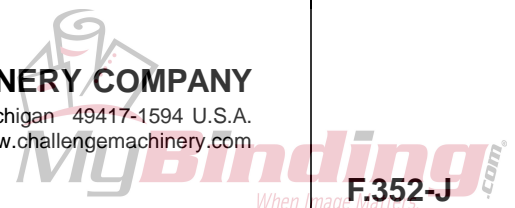
MyBinding.com  
When Image Matters

F.352-J

---

---

## INTRODUCTION

**WELCOME** to the family of Challenge® users. Challenge has been developing and manufacturing Graphics Arts Equipment for over 100 years and is today one of the world's leading producers and distributors of Paper Cutters, Paper Drills and Bindery Equipment.

**THE CHALLENGE REPUTATION** is important to you as a user for the continuous, ready availability of parts and service.

**THIS MANUAL** is designed to help you get the most from your Challenge equipment. Keep this manual in a safe, convenient place for quick reference by operators and service personnel.



**SAFETY ALERT!** This symbol means **CAUTION OR WARNING: Personal safety instructions!** Pay special attention to the instructions in bold type. Personal injury may result if the precautions are not read and followed.

**READ THIS MANUAL BEFORE OPERATING!** Follow precautions and instructions given and you should have years of trouble-free operation. If after reading the manual questions still remain, contact your Authorized Challenge Dealer or the Challenge Service Department. For the dealer nearest you or for service questions call (616)-842-8300.

**FOR PARTS AND SERVICE** contact the Authorized Challenge Dealer from whom you purchased your machine. Use the illustrations and parts lists at the back of this manual to identify the correct parts needed. **Always give the SERIAL NUMBER and MODEL** of your machine to insure that the correct parts are sent as soon as possible.

Take a few minutes right now to **RECORD YOUR MACHINE SERIAL NUMBER** in the space provided on the front cover of this manual. Also be sure to fill out the warranty card accompanying this manual and return it **DIRECT TO CHALLENGE**.

If you bought a used machine, it is important to have the following information on record at Challenge. Copy this page, fill in the information and send it care of: The Challenge Service Department, 1433 Fulton Avenue, Grand Haven, MI 49417-1594. Fax (616) 842-6511. Phone (616) 842-8300.

CHALLENGE MODEL	SERIAL NUMBER	
ATTN	COMPANY	
ADDRESS		
CITY	STATE	ZIP
PHONE	DATE INSTALLED	
DEALER'S NAME AND CITY		

---

---

## WARRANTY INFORMATION

---

---

### **PLEASE REVIEW THE WARRANTY SHEET!**

It is **very important** that you read and understand the conditions outlined in the Warranty Information Sheet. It is in an envelope attached to the outside of the shipping container.

The Warranty Information Sheet must be filled out completely, returned, and be **ON-FILE** at **THE CHALLENGE MACHINERY COMPANY** in order for the warranty to be issued for this machine.

---

---

# TABLE OF CONTENTS

INTRODUCTION.....	2
SAFETY PRECAUTIONS .....	4
CAUTION: POWER LOCK-OUT PROCEDURE .....	4
WARNING LABEL DEFINITIONS .....	5
SPECIFICATIONS .....	6
PACKING LIST .....	7
EH-3C .....	8
INSTALLATION INSTRUCTIONS .....	9
UNCRATING THE PAPER DRILL .....	9
INSTALLING THE TABLE AND BACKGAUGE .....	9
FINAL INSTALLATION .....	9
HOOKING UP THE POWER LINE .....	9
INSTALLING THE CHIP BAG .....	10
OPERATING INSTRUCTIONS .....	10
STARTING THE MACHINE .....	10
OPERATING THE DRILL .....	10
ADJUSTING THE VERTICAL STROKE .....	10
ADJUSTING THE CENTER TO CENTER DISTANCE BETWEEN DRILL HEADS .....	10
ADJUSTING THE BACKGAUGE POSITION .....	11
USING THE SIDE GUIDE .....	11
ADJUSTING THE STROKE SPEED .....	11
REMOVING THE CUTTING BLOCKS .....	11
REMOVING DRILLS FROM THE SPINDLE .....	11
DRILLING TIPS.....	12
ACCESSORIES FOR CHALLENGE PAPER DRILLING MACHINES .....	13

## MAINTENANCE SECTION AND PARTS LISTS

TROUBLESHOOTING .....	20
ROUTINE MAINTENANCE .....	21
MAIN ASSEMBLY - FRONT VIEW .....	24
MAIN ASSEMBLY - UPPER RIGHT VIEW .....	26
MAIN ASSEMBLY - LOWER RIGHT VIEW .....	28
MAIN ASSEMBLY - TOP VIEW .....	29
MAIN ASSEMBLY - WIRING .....	30
ELECTRICAL POWER PANEL ASSEMBLY .....	32
HYDRAULIC/BASE ASSEMBLY .....	34
HYDRAULIC POWER UNIT ASSEMBLY .....	36
HYDRAULIC POWER UNIT .....	37
HYDRAULIC POWER UNIT .....	38
BACKGAUGE ASSEMBLY .....	40
OPTIONAL AUTO-TRIP BACKGAUGE ASSEMBLY .....	42
SPINDLE HEAD ASSEMBLY, RIGHT HAND .....	44
SPINDLE HEAD ASSEMBLY, LEFT HAND .....	45
OPTIONAL DRILL SHIELD KIT .....	46

---

---

## SAFETY PRECAUTIONS



This safety symbol means CAUTION/WARNING - PERSONAL SAFETY INSTRUCTION. Read the instructions because it has to do with safety. Failure to comply with the following instructions may result in personal injury.

- This machine is designed and safeguarded for ONE PERSON operation. NEVER operate the machine with more than one person.
- Safety of this machine is the responsibility of the user and operator. Use good judgement and common sense when working with and around this machine.
- READ and understand all instructions thoroughly before using the machine. If questions still remain, call your Authorized Challenge Dealer - Failure to understand operating instructions may result in personal injury.
- Only trained and authorized persons should operate the machine.
- DO NOT ALTER SAFETY GUARDS OR DEVICES, they are for your protection and should not be altered or removed. Severe lacerations could result.
- DISCONNECT POWER before cleaning, lubricating, servicing, or making adjustments not requiring power. See Power Lockout Procedure below.
- HIGH SPEED DRILL - Keep rags, loose clothing and long hair away from rotating drill. Personal injury could result from items being caught on drill.
- Have your electrician make sure the machine is properly grounded, see Power Hookup, page 9.
- Have your electrician check for sufficient power to operate the machine properly, see page 9.
- OBSERVE ALL CAUTION PLATES AND LABELS on this machine.
- KEEP FOREIGN OBJECTS off table and away from drill.
- BE EXTREMELY CAREFUL when handling and changing the drills. Severe lacerations or dismemberment could result from careless handling procedure.
- KEEP THE FLOOR around the machine free of trim, debris, oil and grease.
- When replacing hydraulic parts, loosen the connections slowly to release pressure. Never loosen connections with the machine running.
- If the machine sounds or operates abnormally, turn it off and consult the Trouble Shooting section of this manual. If the problem cannot be corrected, have it checked by a qualified service person or your Authorized Challenge Dealer.
- CRUSH HAZARD, keep feet off the pedal when handling paper under the clamp. DO NOT REST FOOT ON PEDAL at any time!
- DO NOT REACH UNDER THE DRILL AND CLAMP AREA!
- DO NOT OPERATE WITH ANY GUARDS REMOVED! Replace all guards after adjusting, lubricating or servicing the machine.
- SEVERE LACERATIONS - Contact with high speed drill could cause severe injury. Always turn machine off and wait for drill to stop before removing drill bits. Keep hands away from drill(s) when operating.

### CAUTION: POWER LOCK-OUT PROCEDURE

For maximum safety when making adjustments or repairs to your machine, be sure to lock out the main power control switch to which the machine is connected. The switch should be thrown to the OFF position and a padlock placed in the loop. The key should be held by the person servicing the machine.

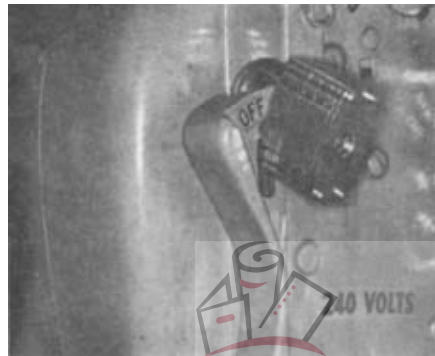

(fig. 1)

---

---

## WARNING LABEL DEFINITIONS

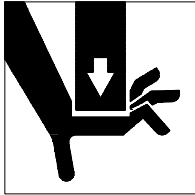

### CUT/CRUSH HAZARD

Keep hands from under drills.



### SINGLE OPERATOR

Do not operate with more than one person.



### SHOCK HAZARD

Disconnect power before removing cover. Replace cover before operation.



### SHOCK HAZARD

Disconnect power before removing cover. Replace cover before operation.



### HAZARDOUS AREA

Disconnect power before cleaning, servicing, or making adjustments not requiring power. Do not alter safety guards or devices, they are for your protection. Replace all guards, do not operate with any guards removed.

---

---

## SPECIFICATIONS

---

### Drilling

Number of Drill Heads	3
Drill Bit Sizes Available	1/8" to 1/2" (3 mm to 13 mm)
Range Between Drills	2 3/4" to 4 1/2" (7 cm to 11 cm)
Range Between Outside Drills	5 1/2" to 9" (14 cm to 23 cm)
Maximum Drilling Capacity (Pile Height)	2 1/2" (63 mm)
Backgauge Adjustment Range (Std. Backgauge)	0 to 5" (0 to 13 cm)
Auto Trip Backgauge (Optional)	0 to 4 1/2" (0 to 11 cm)
Side guide Adjustment Range	0 to 14" (0 to 37 cm)
Vertical Adjustment of Individual Heads	1/4" (6mm)

---

### Dimensions

Table Size	19 1/2" x 31 1/2" (50 cm x 80 cm)
Table Height	37" (94 cm)
Overall Height	59 1/4" (151 cm)
Floor Space Needed	36" x 41 1/2" (91 cm x 105 cm)
Net Weight (Approximate)	525 lbs (236 kg)
Shipping Weight (Approximate)	570 lbs (257 kg)

---

### Electrical

---

208/230 Volts ( $\pm 10\%$ )/18 Amps, 1 Phase, 60 Hz, AC. Service size 30 Amps.

---

Challenge reserves the right to make changes to any product or specification without notice and without incurring responsibility to existing units.

# PACKING LIST

Part No.	Description	Qty.
	Basic Machine .....	1
5700	Backgauge Assembly .....	1
A-5874	Chip Bag .....	1
KK-281-2	Knockout, Cutting Block .....	3
KK-473-3	Drill Blocks, 3" (1 doz) .....	1
CD-4-2-1/2	Hollow Drills, 1/4" Diameter .....	3
CD-5-2-1/2	Hollow Drills, 5/16" Diameter .....	3
K-85	Drift Hole Cover .....	3
A-4950	Drill Sharpener (Hand) .....	1
4685	Drill Cleaner .....	1
4688	Lubrication Stick .....	1
4687	Drill Drift .....	1
W-141	1/8" Allen Wrench .....	1
W-130	3/16" Allen Wrench .....	1
W-137	5/32" Allen Wrench .....	1
5841	.018" Shim .....	3
5841-1	.035" Shim .....	3

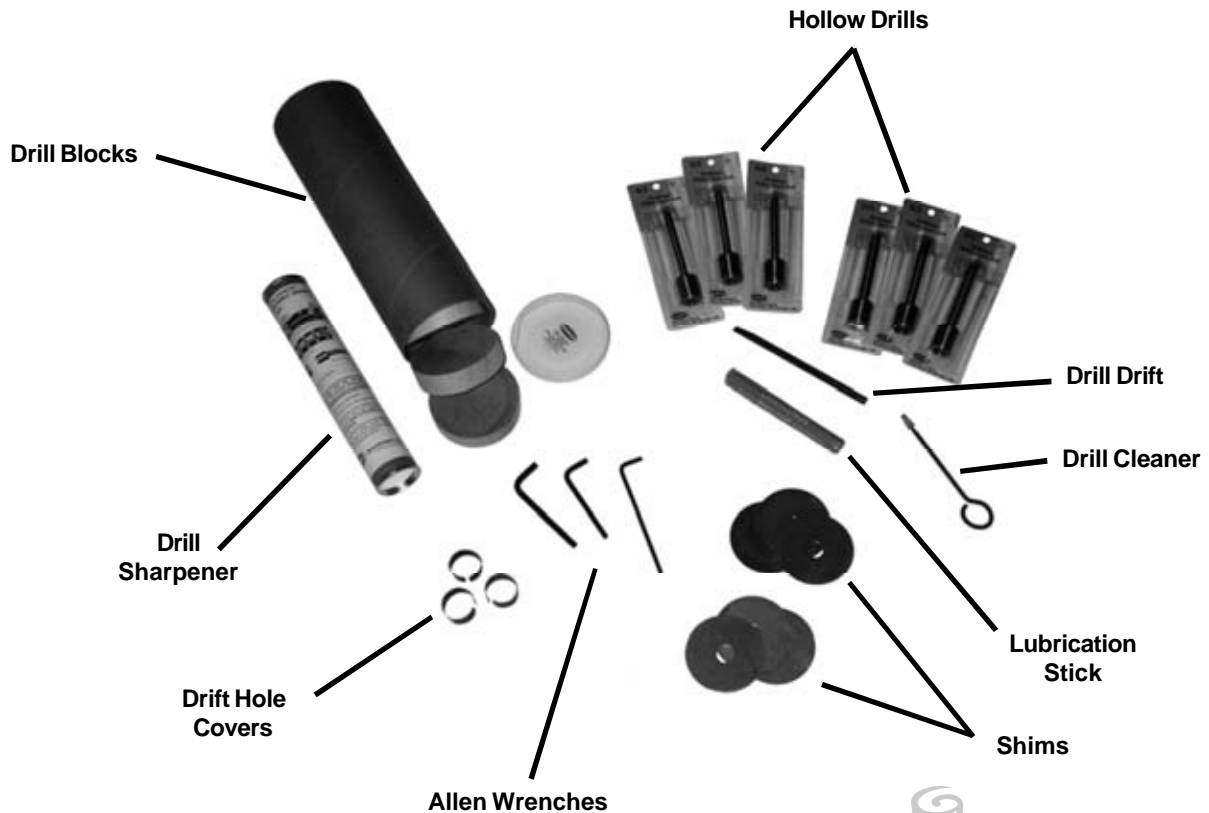





# INSTALLATION INSTRUCTIONS

Refer to figure 2 on the previous page as well as the parts lists and drawings in the back of this manual for part identification and orientation, if necessary.

All guards and instruction plates are installed for your safety and information and must remain on the machine as shipped from the factory.

## UNCRATING THE PAPER DRILL

This machine is shipped on a wooden skid and is enclosed with a protective corrugated cover. It is held onto the skid with plastic straps. Remove the straps and carefully cut the corrugated cover down the side and unwrap it from around the machine. The table, backgauge, and other accessories are packed in separate boxes and are secured to the machine. Remove these and carefully position the machine on the floor. Immediately after uncrating, check off parts received against the packing list. Also, examine for any physical signs of damage incurred during shipping. The machine is inspected before and after it is crated at our plant. The responsibility for filing a claim against the carrier for damages incurred during shipment rests with the receiver of goods (FOB our factory).

Clean all parts with a commercial cleaning solvent before installing or using the machine.

## INSTALLING THE TABLE AND BACKGAUGE

Locate four (4) table mounting bolts shipped in the backgauge box [(2) 5/16-18 x 1" shoulder bolts; (2) 1/4-20 x 1-3/4" carriage bolts]. The two carriage head bolts go into the rear table mounting holes and the two shoulder bolts go into the front mounting holes. Mount the table, but leave the hardware loose. Slide the backgauge on the table and align the backgauge face to the 1" mark on both of the scales; fasten the backgauge to the table

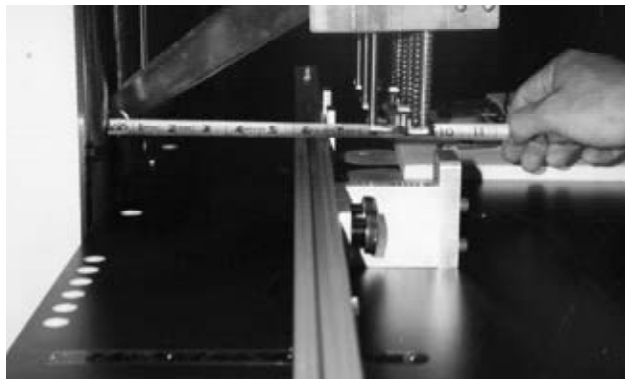

(fig. 3)

with the thumbscrews provided.

Next, position the table so that the face of the backgauge measures exactly the same distance from the front of each pull down shaft (fig 3). When this is accomplished tighten the table mounting hardware.

## FINAL INSTALLATION

Place the drill block knock-outs in position. Now set the three drill blocks place. Check to see if the blocks are flush with the table. Place shims under the blocks if necessary.

Insert the tapered head of the hollow drills into the spindles. Be sure that the drift hole covers are in place before operating the machine (fig 2). The drift hole covers prevent paper chips from flying out while drilling.



**CAUTION: Always handle drills with care to avoid severe lacerations. Even dull drills are sharp enough to cause lacerations.**

Check the level of the oil in the hydraulic reservoir. This check is made by first removing the louvered panel at the left side of the stand (two screws hold it in place) and locating the breather cap on the top of the reservoir. The breather cap has a dip stick attached for checking the oil. When screwed in (and then removed to check) there should be approximately an 1/8" (3 mm) of oil on the stick. Some machines are equipped with a clear reservoir in which case the oil level can be checked by visually inspecting the oil level. There is a full level line marked on the reservoir. Recommended oils are found in the maintenance section of this manual (pg. 23).



**CAUTION: Always disconnect the power when cleaning, servicing, or lubricating your drill, see Lock Out Procedures, pg. 4.**

## HOOKING UP THE POWER LINE

The EH-3C is factory wired for 208/230 Volt, 1 phase, 50/60 hz. operation. It is the customer's responsibility to wire the machine for the rated voltage using a 30 Amp circuit (minimum). The recommended circuit overload protection device should be 20 Amps. The recommended wire size for this hookup is #10 gauge.

It is important that the proper line voltage be maintained. Failure to do so will result in improper operation of the machine (see the troubleshooting section of this manual

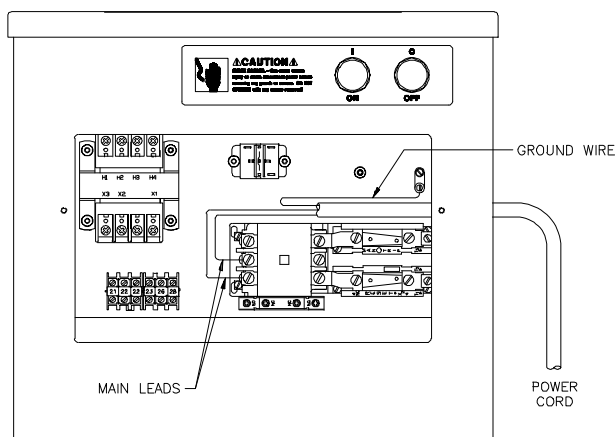

(fig. 4)

for specific problems). It may be necessary to provide a separate branch power line for the machine.

Since the standard machine is intended for a single phase hookup, simply fasten either wire of the power cord to either terminal of the starter and the ground wire to the designated terminal (fig. 4).

### INSTALLING THE CHIP BAG

The chip container bag is installed by slipping it over the two hooks provided on the rear of the machine.

## OPERATING INSTRUCTIONS

### STARTING THE MACHINE

The power for this machine is supplied by two motors; one is for the hydraulic power pack, the other is for the spindle. They are both started and stopped simultaneously by a single set of start-stop buttons located on the stand under the table (fig. 1). Be sure both motors are operating before trying to drill paper.

### OPERATING THE DRILL

Pressing down on the foot switch activates the hydraulic unit which brings the drill heads down through the stock. When the drills reach the bottom of their stroke, they will automatically return the "up" position. (Note: The vertical stroke of the drills must be set before drilling to provide the proper drill depth. See the following section for adjustment procedures). The pedal must be released and depressed again before drilling the next set of holes, assuring full control and allowing no repeat stroke. By releasing the pedal, the operator can stop the drills in their downward stroke at any time allowing them to return to their normal position, thus preventing

costly errors. **NEVER REST YOUR FOOT ON THE TREADLE WITHOUT INTENDING TO BRING DOWN THE DRILLS!**

### ADJUSTING THE VERTICAL STROKE

The vertical stroke of the machine determines the exact depth the drills will reach at the bottom of their stroke. Whenever installing a new set of drills, the vertical stroke must be adjusted before drilling.

The two outside heads are provided with independent height adjustment while the center head works from the center overall adjusting screw. This is necessary because of the variance in length of the drills. Start by adjusting the center head to its highest point. This is accomplished by turning the drill depth adjustment screw (fig. 2) counterclockwise until it stops turning. Then adjust the side heads all the way up by turning the knurled ring on the heads clockwise (use the provided drill drift in the holes if necessary). Now, with the new drills in the place, put two or three sheets of paper under the heads. The center spindle should then be adjusted so that the center drill just cuts through the paper. Too deep will cause a ragged hole in the bottom sheets as well as a shorter drill life from drilling into the cutting block. After the center drill is adjusted, each outside spindle can be adjusted. Turn counterclockwise to lower and clockwise to raise. No locking is necessary. Once all three drills are set, drill through a full lift of stock. A final adjustment of the drill depth adjusting screw may be necessary to obtain the best results.

### ADJUSTING THE CENTER TO CENTER DISTANCE BETWEEN DRILL HEADS

This machine incorporates three drilling heads operating on three belt-driven spindles. The center head is stationary while the two outside heads have a lateral adjustment of  $1\frac{3}{4}$ " each.

This provides an adjustment range of  $2\frac{3}{4}$ " to  $4\frac{1}{2}$ " (7 cm to 11 cm) between the center drill and either of the outside drills, or a range of  $5\frac{1}{2}$ " to 9" (14 cm to 23 cm) between the two outside drills.

The lateral adjustment is accomplished by loosening the clamp knob (a black, plastic hand knob) located at the rear of each outside head, and then turning the 4-lobed, black knob located at the outside of each head. This moves the heads along a shaft. A scale and pointer located at the front of the heads gives a reading in inches and millimeters of the center line relationship to the center head. When a setting is made, make certain that the clamp knob is tightened again.

Any combination of three heads can be used, that is one, two, or three holes may be drilled if desired. It is recommended, however that no more than two half inch hollow drills be used at the same time.

### ADJUSTING THE BACKGAUGE POSITION

The backgauge position is adjusted by first loosening the two thumb screws under the table. This will allow the backgauge to move freely. Then use the two scales on the top of the table to set the backgauge to the desired position. The scales read in inches and millimeters and will give the distance from the edge of the sheet to the center of the holes. Be sure the 1" (2.5 cm) square pieces mounted to the backgauge are aligned on top of the scales to provide the proper reading (fig. 2). Tighten the thumbscrews when finished.

### USING THE SIDE GUIDE

To adjust the position of the side guide, loosen the two black knobs until the side guide is free to slide sideways. Slide the side guide to the desired position and then tighten the two knobs. For certain hole positions, it may be necessary to remove the rectangular spacer from the side guide assembly (fig. 5).

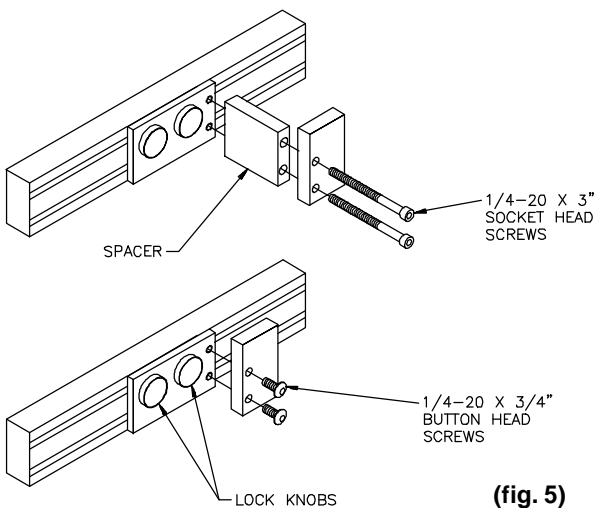

(fig. 5)

### ADJUSTING THE STROKE SPEED

The hydraulic unit is equipped with an adjustable valve for regulating the speed on the drill stroke (up and down travel). Soft stocks such as mimeographs, etc., are apt to wrinkle at high speeds, and the speed should be set to a point where the best results are obtained.

This adjustment is made by turning the adjustable valve (located on the right side of the drilling machine stand) counterclockwise to reduce speed and clockwise to increase speed (fig. 6)

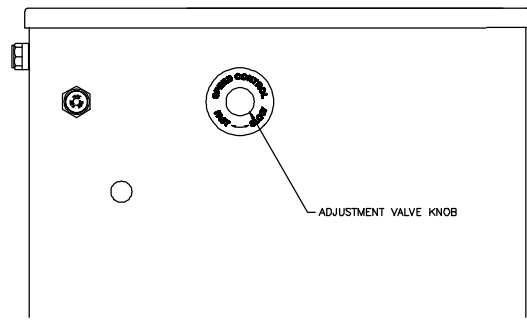

(fig. 6)

### REMOVING THE CUTTING BLOCKS

Each cutting blocks is removed by inserting your fingers in the hole provided in the frame (under the table) and pushing up on the cutting stick knock out. There are three holes; one on each side of the frame and one in the front.

### REMOVING DRILLS FROM THE SPINDLE

Remove the drift hole cover from the spindle to expose the drift hole. Then, with the flat side down, insert the drill drift into the hole and lift upward. The upward movement forces the drill down and releases it from the spindle.

---

---

## DRILLING TIPS

**Important!** To prevent the drill from overheating, always avoid drilling too slowly. The drill stroke speed should be set at the fastest speed possible that still allows the drills to cut easily through the paper.

**Slotted Holes** - Instead of punching slotted holes for five and seven hole universal binding work, save time and cost by drilling a 1/2" (1.3 cm) diameter hole in place of the slot. The slot is only intended to allow the post or ring to be used in either location, and the large hole permits this.

**Plastic Bindings** - Drilling holes for plastic bindings, instead of punching them, is practical and saves a great deal of time, particularly on long run jobs.

**Keep Drills Sharp** - A dull drill is the major cause of drill breakage and production tie-ups. Usually after three hours of drilling, depending on the type of paper being processed, the drill should be sharpened. A dull drill results in poor quality work.

**Keep Drills Clean** - A dirty and rusty drill will not permit the free upward passage of the drill chips. Pressure built up by a clogged drill will split or break the drill. To keep it free from dirt or rust, clean the drill of all chips after each use and apply a light oil to the inside and outside. Drills should be cleaned out immediately after each use. This is particularly true if a coated or varnished stock has been drilled. On these jobs the coating on the chips frequently fuse the chips into one solid mass when the drill cools, causing breakage the next time the drill is used.

**Lubricate Drills** - Lubrication assists in the passage of the chips and helps avoid overheating of the drills. Use readily available stick lubricants for this purpose. Hold the end of the stick against the side of the rotating drill. Be sure to touch the cutting edge with the lubricant also. Wipe off excess oil before drilling. **CARE MUST ALWAYS BE TAKEN WHEN HANDLING DRILLS.**

**Keep Spindle Clean** - Clean out the drill spindle frequently. This will prevent any buildup in the spindle of the drill.

**Set the Drills Correctly** - Do not cut too deeply into the cutting block. The drill should just touch the block and cleanly cut through the bottom sheet. During drilling, do not set the drill deeper into the block but change the position of the block frequently. Drilling deeper into the block dulls the drills quickly. Use a piece of chipboard underneath your stock. This will make handling the stock easier and will ensure that the last sheet is cut cleanly through.

**Check for Drill Wobble** - If spindles are badly worn or bent through misadjustment, have them replaced immediately. A wobbly or loosely held drill can break.

**Check Your Drill Sharpener** - The cutting edge of the sharpening bit should be inspected frequently to make certain that it is sharp and free of nicks. Never let a drill drop onto the sharpening bit. It will chip the sharpening edge. Use gentle pressure when sharpening - let the sharpening bit do the work. Check the sharpness of the drill after sharpening. The cutting edge should be razor sharp.

**Check Belt on the Drilling Machine** - The belt should be kept tight to assure proper speed of the drill. When the drill slows down, it acts more like a punch which results in poor quality work and drill breakage.

Just a little time and effort taken with each use of your paper drilling machine should result in trouble free operation over many years.

# ACCESSORIES FOR CHALLENGE PAPER DRILLING MACHINES

## Genuine Challenge Hollow Drills In 13 Standard Sizes For Every Drilling Need

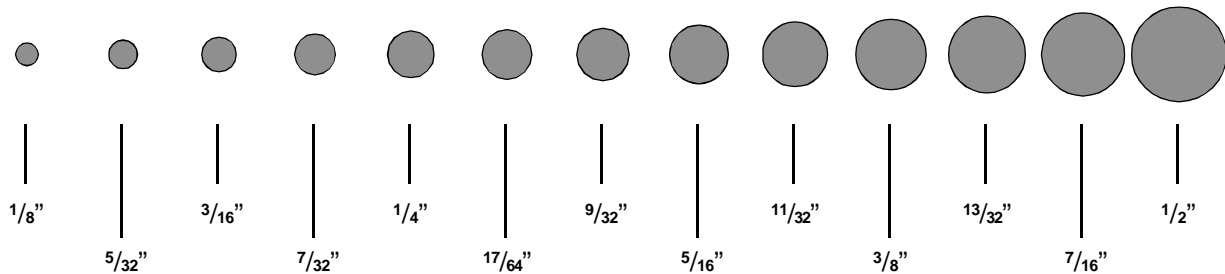

All drills carried in stock by local Challenge dealers (<sup>17</sup>/<sub>32</sub>" & <sup>9</sup>/<sub>16</sub>" available by special order).

### HOLLOW DRILLS

Diameter x Drill Capacity	Cat. No.
1/8" x 5/8" (3.2 x 16 mm)	CD-2-3
5/32" x 1 1/8" (4 x 29 mm)	CD-52
3/16" x 1 5/8" (4.8 x 41 mm)	CD-3
7/32" x 2" (5.6 x 51 mm)	CD-72
1/4" x 2" (6.3 x 51 mm)	CD-4
1/4" x 2 1/2" (6.3 x 63.5 mm)	CD-4-2 1/2
17/64" x 2" (6.7 x 51 mm)	CD-174
9/32" x 2" (7.1 x 51 mm)	CD-92
5/16" x 2" (7.9 x 51 mm)	CD-5
5/16" x 2 1/2" (7.9 x 63.5 mm)	CD-5-2 1/2
11/32" x 2" (8.7 x 51 mm)	CD-112
3/8" x 2" (9.5 x 51 mm)	CD-6
3/8" x 2 1/2" (9.5 x 63.5 mm)	CD-6-2 1/2
13/32" x 2" (10.3 x 51 mm)	CD-132
7/16" x 2" (11.1 x 51 mm)	CD-7
1/2" x 2" (12.7 x 51 mm)	CD-8
1/2" x 2 1/2" (12.7 x 63.5 mm)	CD-8-2 1/2
Special order drills	
17/32" x 2" (13.5 x 51 mm)	CD-172
9/16" x 2" (14.3 x 51 mm)	CD-9

### TEFLON COATED HOLLOW DRILLS

Diameter x Drill Capacity	Cat. No.
1/8" x 5/8" (3.2 x 16 mm)	TCD-2-3
5/32" x 1 1/8" (4 x 29 mm)	TCD-52
3/16" x 1 5/8" (4.8 x 41 mm)	TCD-3
7/32" x 2" (5.6 x 51 mm)	TCD-72
1/4" x 2" (6.3 x 51 mm)	TCD-4
1/4" x 2 1/2" (6.3 x 63.5 mm)	TCD-4-2 1/2
17/64" x 2" (6.7 x 51 mm)	TCD-174
9/32" x 2" (7.1 x 51 mm)	TCD-92
5/16" x 2" (7.9 x 51 mm)	TCD-5
5/16" x 2 1/2" (7.9 x 63.5 mm)	TCD-5-2 1/2
11/32" x 2" (8.7 x 51 mm)	TCD-112
3/8" x 2" (9.5 x 51 mm)	TCD-6
3/8" x 2 1/2" (9.5 x 63.5 mm)	TCD-6-2 1/2
13/32" x 2" (10.3 x 51 mm)	TCD-132
7/16" x 2" (11.1 x 51 mm)	TCD-7
1/2" x 2" (12.7 x 51 mm)	TCD-8
1/2" x 2 1/2" (12.7 x 63.5 mm)	TCD-8-2 1/2

### Challenge Drill-Ease Lubricant Stick

Cat. No. 4688

This lubricating stick provides a dry stainless lubricant which has many uses throughout the printing plant. It is specially recommended for use on hollow drills for easier drilling, particularly when drilling clay coated stock. It eliminates binding and excessive heating of the drill. Will not discolor the stock.

**CARE MUST ALWAYS BE TAKEN WHEN USING STICK AND HANDLING DRILLS.**

### Challenge Drilling Blocks

Cat. No. KK-473-3

These Challenge 3" End-Wood Drilling Blocks are for round hole drilling operations. Sold in packages of 12.



## ACCESSORIES FOR CHALLENGE PAPER DRILLING MACHINES



### Challenge Power Sharpener

(115 Volt / 60 HZ only)

Cat. No. A-6450

A power drill sharpener. Plugs into any standard 115 volt, 60 cycle, AC outlet. Handles Challenge and other taper shank drills. Adaptors also available for handling practically all other makes.

Item	Cat. No.
Replacement Cutting Bit	6469
Resharpener Service - Your Old Bit	6469-R

## HOLLOW DRILL SHARPENER *For fast, easy drill sharpening*



**CAUTION:** Drills are sharp even after use. Be careful to keep edge away from your body. To prevent personal injury and/or damage to the drill, ALWAYS keep drills in protected area.

Here's a unit that really makes drill sharpening easy. All you do is place the hollow drill in the tapered end of the drill holder, insert the unit on the cylinder, then turn two or three times, and you have a perfectly sharpened drill.

This Challenge Hollow Drill Sharpener can pay for itself many times over through longer drill life, easier, faster drilling, and less sharpening time. All sizes of drills from 1/8 to 1/2 inch in diameter can be sharpened.

The drill sharpener automatically puts just the right amount of bevel on the hollow drill for the best drilling results. It's self centering, too, so that the center of the sharpening bit exactly meets the center of the hollow drill. The drill sharpener also has a replaceable sharpening bit.

Item	Cat. No.
Challenge Hollow Drill Sharpener	A-4950
Extra Cutting Bit	4952

### Instructions:

**NOTE:** Always handle carefully

1. Be sure to wipe off all grease before using the sharpener.
2. Remove any paper chips from the hollow drill.
3. Place the hollow drill in the drill holder section. Insert the sharpening section, being very careful to bring the drill and cutting tool together without bumping.

**NOTE:** The cutting tool is made of a glass hard material and may be chipped by careless handling.

4. Turn the cutting unit clockwise, maintaining an even pressure until the hollow drill is sharpened (usually two or three turns).

---

---

## ACCESSORIES FOR CHALLENGE PAPER DRILLING MACHINES

---

### Right Side Sideguide Kit K-5731

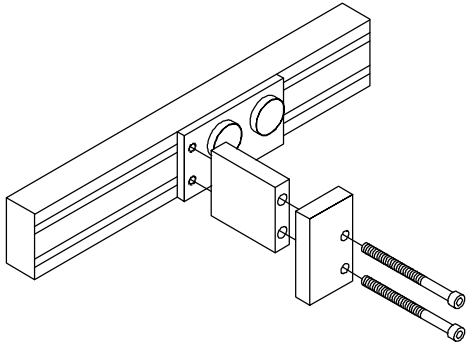

This kit includes all of the parts and hardware necessary to add a right-hand sideguide to your existing backgauge. When used in conjunction with the left-hand sideguide, multiple hole patterns can be drilled by shifting the stock from one sideguide to the other between drilling cycles.

---

### Auto-Trip Backgauge A-4615-9

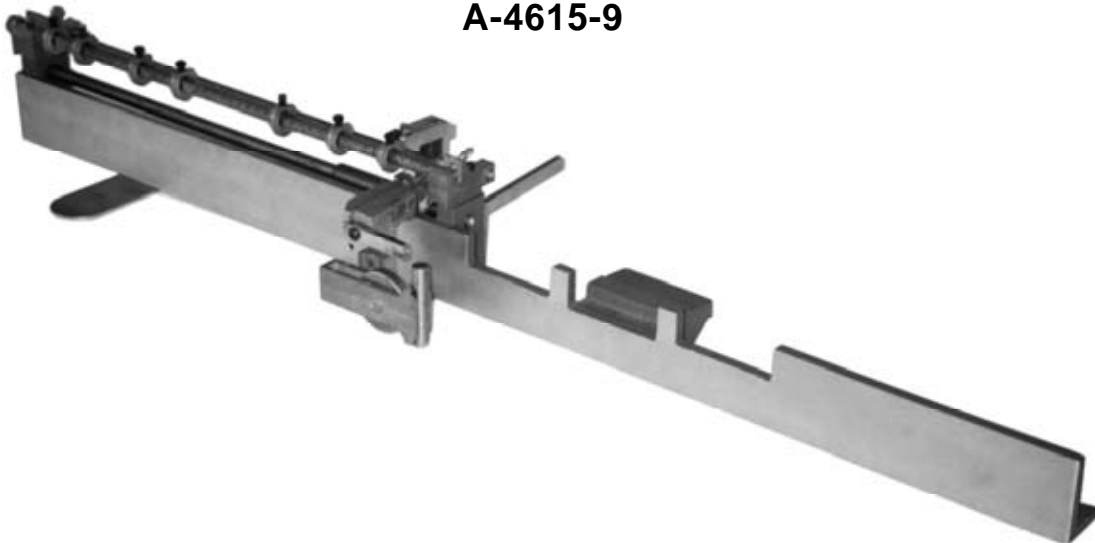

#### OPTIONAL AUTO-TRIP BACKGAUGE

This optional backgauge assembly provides additional versatility to the EH-3C. The automatic trip on the side guide permits step and repeat type of operation with a minimum distance between holes of  $\frac{3}{8}$ " (9.5 mm) with the standard stops or  $\frac{1}{4}$ " (6.3 mm) minimum by the use of a fixed gage, available as optional equipment.

As each set of holes is drilled, the side guide is automatically tripped, and as soon as the drills clear the stock on their up stroke, the guide is free to move to its next stop. This is accomplished by pushing the stock to the left and moving the guide at the same time. When drilling one, two or three holes only, that fall within the 9" (23 cm) limitations of the machine, the automatic trip bracket (located at the left of the machine) can be turned so that it does not engage the trip lever.

#### SETTING THE SIDE GUIDE STOPS

First set the rear gage to the desired back margin. Be sure both sides are set to the same dimension and tighten the two thumbscrews. Next, remove the guide shaft and set the guide stops to the desired distance between holes (a scale in the guide shaft is provided for this purpose). The guide shaft is then replace in the rear gage and final adjusting or centering of holes is accomplished with the knurled screw at the extreme left end of the guide shaft.

The automatic trip gage comes equipped with seven stops. Additional stops can be purchased at a very nominal price. Challenge fixed index gages are recommended where the same job is to be handled over and over again. They are easily and quickly attached and removed. NOTE: When drilling narrow strips, the side guide roller assembly should be mounted on the inside of the side guide assembly.



---

---

## ACCESSORIES FOR CHALLENGE PAPER DRILLING MACHINES

### Fixed Gages

*For Fast, Accurate Hole Spacing*  
(For use with optional auto-trip backgauge only)

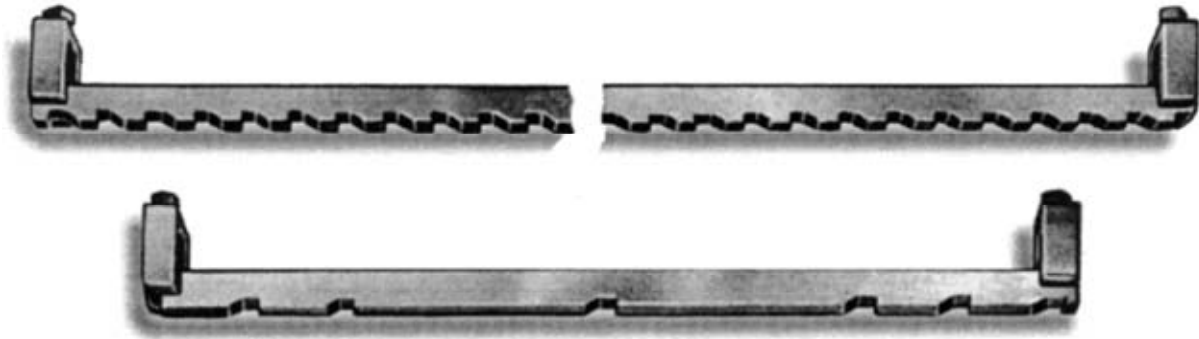

These fixed gages with pre-cut hole spacings fit on the side guide in place of the moveable stops. To use, position the gage so that the right end lines up with the dimension on the scale for the centerline of the first hole to be drilled. Use of the stops on fixed gages is the same as using the adjustable stops.

In addition to 2-5 hole patterns, fixed gages are available from stock in the following standard types:

22-stop gage, 1/2" centers for multi-ring binders  
25-stop gage, 3/8" centers  
25-stop gage, 1/4" centers  
34-stop gage, 1/2" centers  
46-stop gage, 3/8" centers  
50-stop gage, 1/4" centers

Custom patterns can also be supplied, call for details.

---

---

## ACCESSORIES FOR CHALLENGE PAPER DRILLING MACHINES

### 2-Hand Control Kit A-4851-50

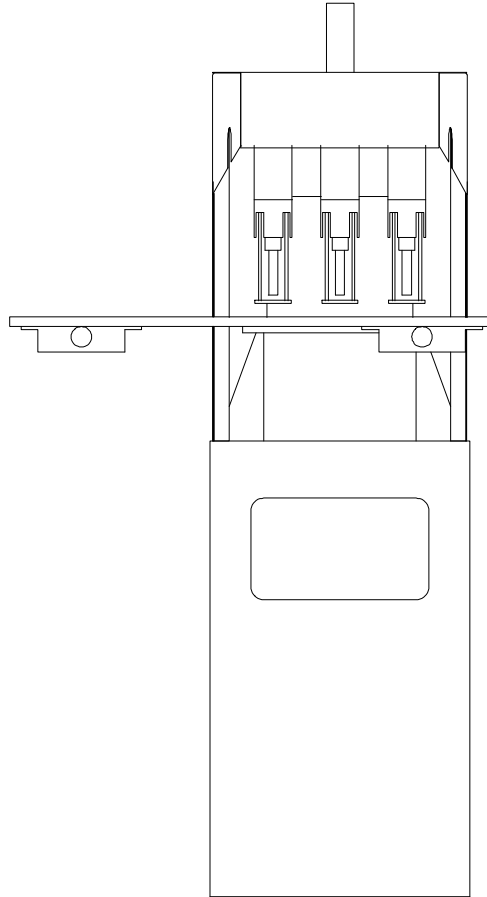

This 2-hand control safety kit can be installed on the EH-3C in place of the standard foot pedal control. All of the necessary hardware and instructions are included in the kit. The 2-hand control offers anti-tiedown and

anti-repeat features, which means both buttons must be released between each cycle, and both buttons must be pressed within .5 seconds of each other.

---

---

## ACCESSORIES FOR CHALLENGE PAPER DRILLING MACHINES

### Drill Shield Kit 48004

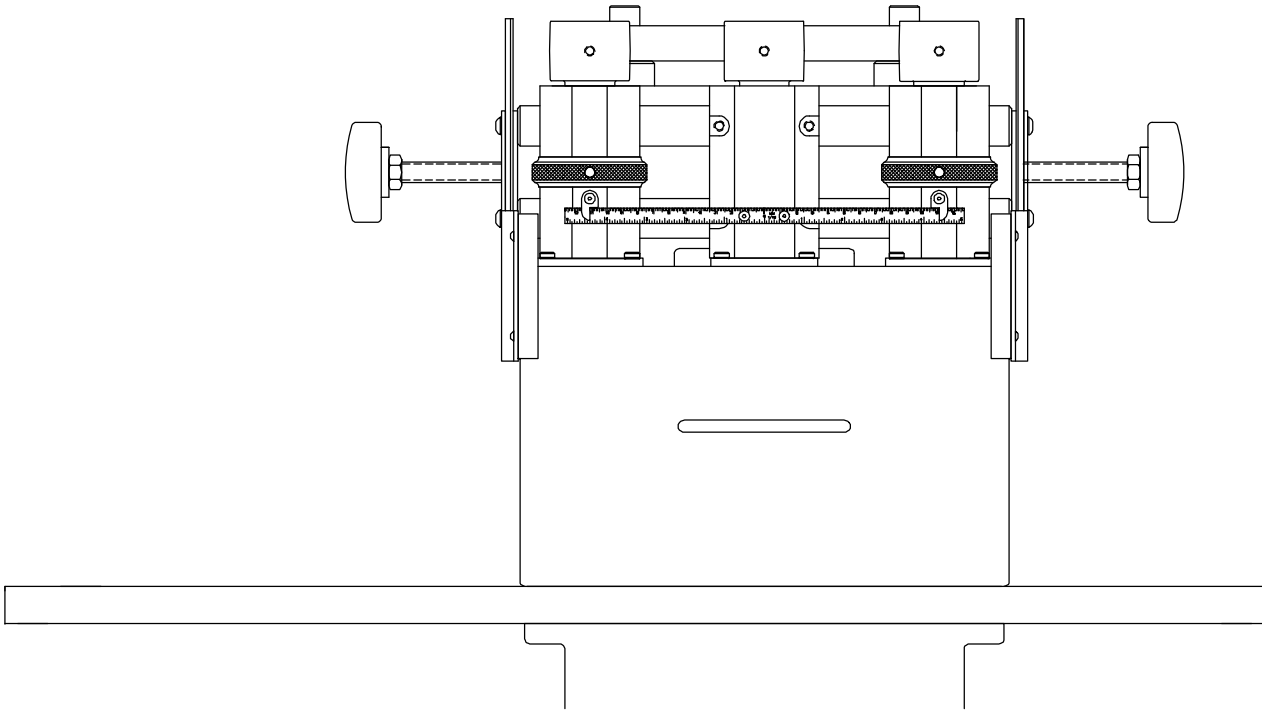

This drill shield safety kit includes a clear Lexan shield that protects the operator from contacting the spinning drills. The kit can be installed on all EH-3A, EH-3B,

and EH-3C machines. All of the necessary hardware and instructions are included in the kit.

---

---

# **⚠ NOTICE ⚠**

**The instructions on the following pages are for the use of trained service personnel only!**

**Attempting to perform repair and replacement procedures without proper training may cause machine damage or operator injury!**

**PARTS CUSTOMERS:** The Challenge Machinery Company provides parts with the express understanding that they are to replace parts found missing or no longer serviceable on equipment designed and/or manufactured by Challenge. The Challenge Machinery Company assumes no liability for any modification or alteration to any Challenge products, and any such modification or alteration to any Challenge products is not authorized by The Challenge Machinery Company. Any modification or alteration of any Challenge product will void any remaining warranty.

# TROUBLESHOOTING



**WARNING: DISCONNECT THE POWER AND LOCK IT OUT** whenever working on the machine unless the instructions specifically require the machine to be powered (see Power Lockout Procedure, [page 4](#)). Some of the following tests may require the machine to be operational for checking and adjusting. Be very careful that tools and other people are clear of moving parts, and that the drill is not accidentally operated while adjustments are being made.



**CAUTION:** Whenever repairing hydraulic components, loosen connections slowly to bleed off any trapped pressure.

Problem	Area to Check	Solution
1. No power	Power to machine	Connect Power
	Fuse blown	Replace fuse
2. Lack of power	Relief valve in pump may be bad or have dirt in it.	Clean or replace relief valve or pump.
	Check oil level - may be low.	Add oil.
	Check voltage at machine - may be low.	Remove other machinery on line or provide a dedicated line.
3. Drill head won't return	Check lift springs - may be broken or stuck (replace if necessary).	Pry up head, clean & oil shafts.
	Pull down shafts froze in frame.	Pry up head, clean & oil shafts.
4. Drill head won't come down	Check for broken lift spring - may be jammed.	Replace spring.
	Speed control valve out of adjustment or defective.	Try to readjust, may have to replace.
5. Spindle motor stalls	Dull drills.	Sharpen drills.
	Check for low voltage.	(See above).
	Drive belt may be loose.	Adjust belt tension. (See Adjustment section of this manual).
	Check for paper plugging drills	Clean out hollow drills - We recommend cleaning and soaking drills in oil overnight.

---

---

# ROUTINE MAINTENANCE



**CAUTION:** Always disconnect the power when cleaning, servicing, or lubricating your drill, see Lock Out Procedures, pg. 4.

## General

Production losses can be reduced if good maintenance practices are followed. The following suggestions may be helpful:

1. Recognize the fact that the user of hydraulic equipment has more control over maintenance than the manufacturer.
2. Operators should be familiar with use, care, and limitations of the equipment. **ALL OPERATORS SHOULD READ THIS MANUAL COMPLETELY.**
3. Use properly trained maintenance personnel.
4. Establish a program of systematic preventative care for your equipment or put this machine on an existing preventative maintenance program.
5. Analyze and isolate trouble before having any part of the equipment dismantled.
6. Be aware of how your machine should sound and perform. If the machine is not operating properly or if it doesn't "sound right", stop running your job immediately and try to identify the problem.
7. Call the dealer for any problems that cannot be handled by your own personnel.

## Daily

1. Sharpen the hollow drills often and reset the spindle adjusting knobs if needed.
2. Lubricate the hollow drill frequently with the lubricating stick provided.
3. For better hollow drill life, remove the drills when not in use, clean out, and soak in light oil. Wipe off excess oil before drilling.

## Weekly (or every 40 hours of operation)

1. Check the drive belt tightness and wear. The drive belt must be kept tight or it will stall the motor and plug or break the drills. See the Adjustments sec-

tion for instructions on how to tighten the belt.

2. Clean and oil the guide bar shafts around frame.
3. Clean and oil the rear support brackets.

## Monthly

1. Check the hydraulic oil supply for the proper level. This check is made by removing the rear panel and visually inspecting the level of the oil in the clear reservoir. The oil should be filled to the fill line on the tank. If your machine is equipped with a dip stick on the breather cap, remove the cap and check the dip stick. There should be approximately 1/8" (3 mm) of oil on the stick.

Use only one of the recommended oils or an ISO VG 100 Hydraulic Fluid equivalent. Oils other than the recommended type will cause seals, cups and O-rings to deteriorate. See Chart & CAUTION. (pg. 23)

## Yearly

1. Check all adjustments.
2. Tighten all screws.
3. Change hydraulic oil in reservoir. Oil may have to be changed more often if contamination of any kind gets in the oil. (Capacity: 1 1/2 Quarts/1.4 liters)
4. Grease lift springs.

## Drill Heads

Through normal use, bearings will wear and need replacing. Signs of wear are excessive noise, heat, or loose spindles.

See the following page for bearing replacement procedures.

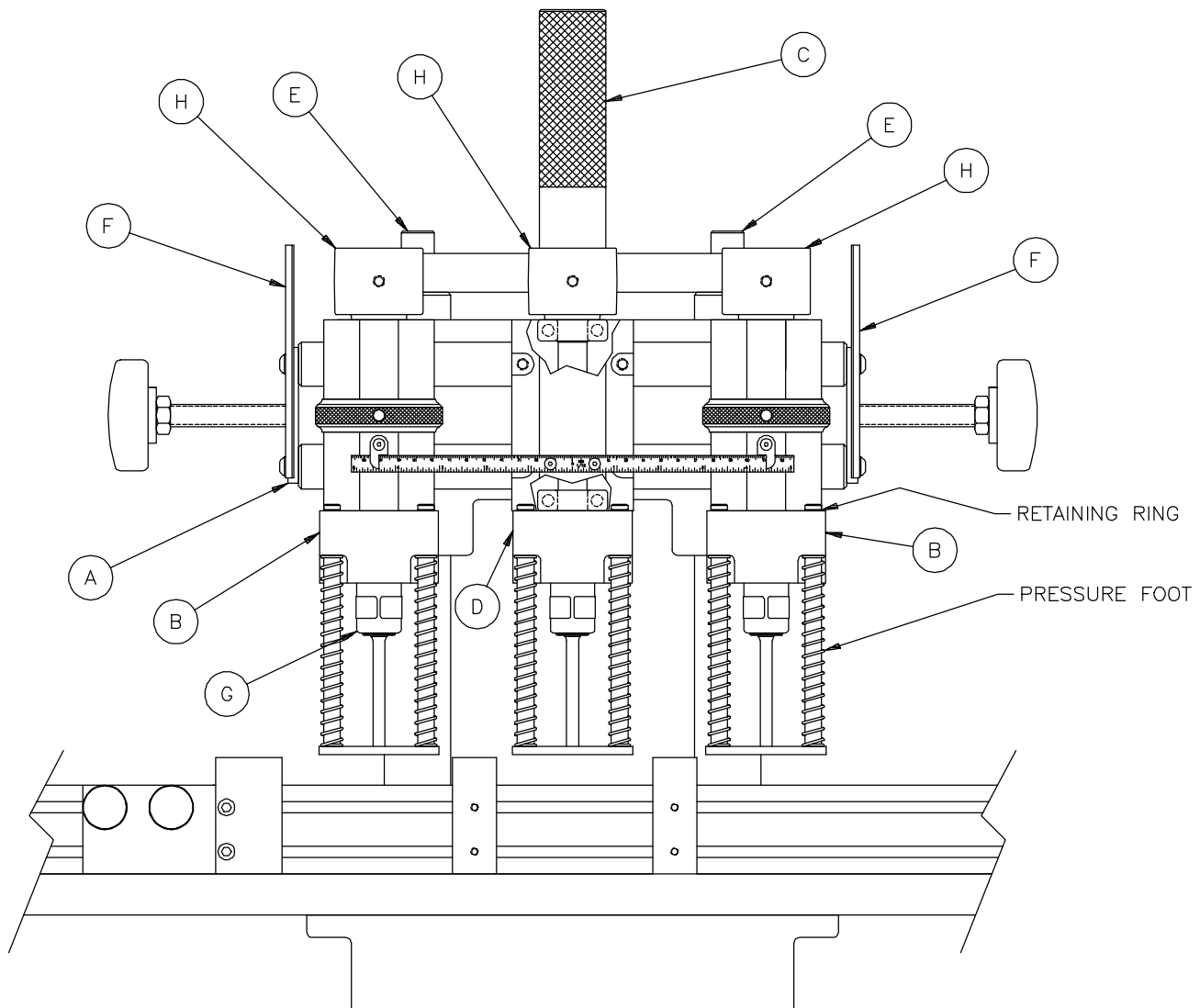

**CAUTION:** Always disconnect the power when cleaning, servicing, or lubricating your drill, see Lock Out Procedures, pg. 4.

### Bearing Replacement Procedure

1. Remove cover.
2. Remove belt.
3. Remove chip pan assembly.

### Side Head Bearing Replacement

1. Remove end plate "A" and shield "F" from shaft.
2. Slide head off shafts.
3. Remove chip chute "B" from head.
4. Remove pulley "H" from spindle.
5. Tap spindle "G" out from head.

6. Tap out bearings (must use rod from opposite end of each bearing).
7. Tap the upper bearing (S-706) in place using a piece of wood between the hammer and the bearing (an old drill block works fine).
8. Place the lower bearing (S-706) on the spindle and tap in the spindle and bearing simultaneously. Use the wood block from the previous step to protect the spindle.
9. Replace the chip chute and pulley.

### Center Head Bearing Replacement

1. Raise head as far as possible by turning knob "C".
2. Remove pulley "H".
3. Remove chip chute "D".
4. Remove cutting block from table.
5. Back off bolts "E" approximately 1/2" and slide head up on rods so there is enough clearance between

---

---

table and bottom of head to allow spindle to be removed (place block between table and head to hold in up position).

6. Tap out spindle (down).
7. Tap out bearings (must use rod from opposite end of each bearing).
8. Tap the upper bearing (S-706) in place using a piece of wood between the hammer and the bearing (an old drill block works fine).
9. Place the lower bearing (S-706) on the spindle and tap in the spindle and bearing simultaneously. Use the wood block from the previous step to protect the spindle.
10. Replace the chip chute and pulley.
11. Adjust head for drill depth.

### Hydraulic

Through normal use, hydraulic systems gum up and seals wear. Signs of wear are hydraulic leaks and erratic operation of the vertical speed. Check with your Authorized Challenge Dealer for a current repair and/or replacement policy. Replace oil yearly. (Capacity: 1½ Quarts/1.4 liters)

### Recommended Oils

Oil Name	Distributor
Rykon No. 100	AMOCO
Duro AW Oil 465	Arco
AW Machine Oil 100	Chevron
Pacemaker XD No. 100	Citgo
Super Hydraulic 100	Conoco
Nuto H-100	Exxon
Harmony 100 AW	Gulf
HO 2A Hydraulic Oil	Lubriplate
DTE No. 18	Mobil
Pennzoil AW 100	Pennzoil
Magnus A Oil 215	Phillips
Tellus 100	Shell
Energol HLP 100	Sohio
Industron 100	Std. Oil Indiana/Boron
Sunvis 851 WR	Sunoco
Rando HD 100	Texaco
Unax AW 100	Union Oil Co.



**CAUTION: NEVER USE Automatic Transmission oil or brake fluid as a substitute! Oils other than the recommended type will cause seals, cups and O-rings to deteriorate. Unsafe operating conditions will result.**



# MAIN ASSEMBLY - FRONT VIEW

## A-5846-9 SHEET 1 OF 5

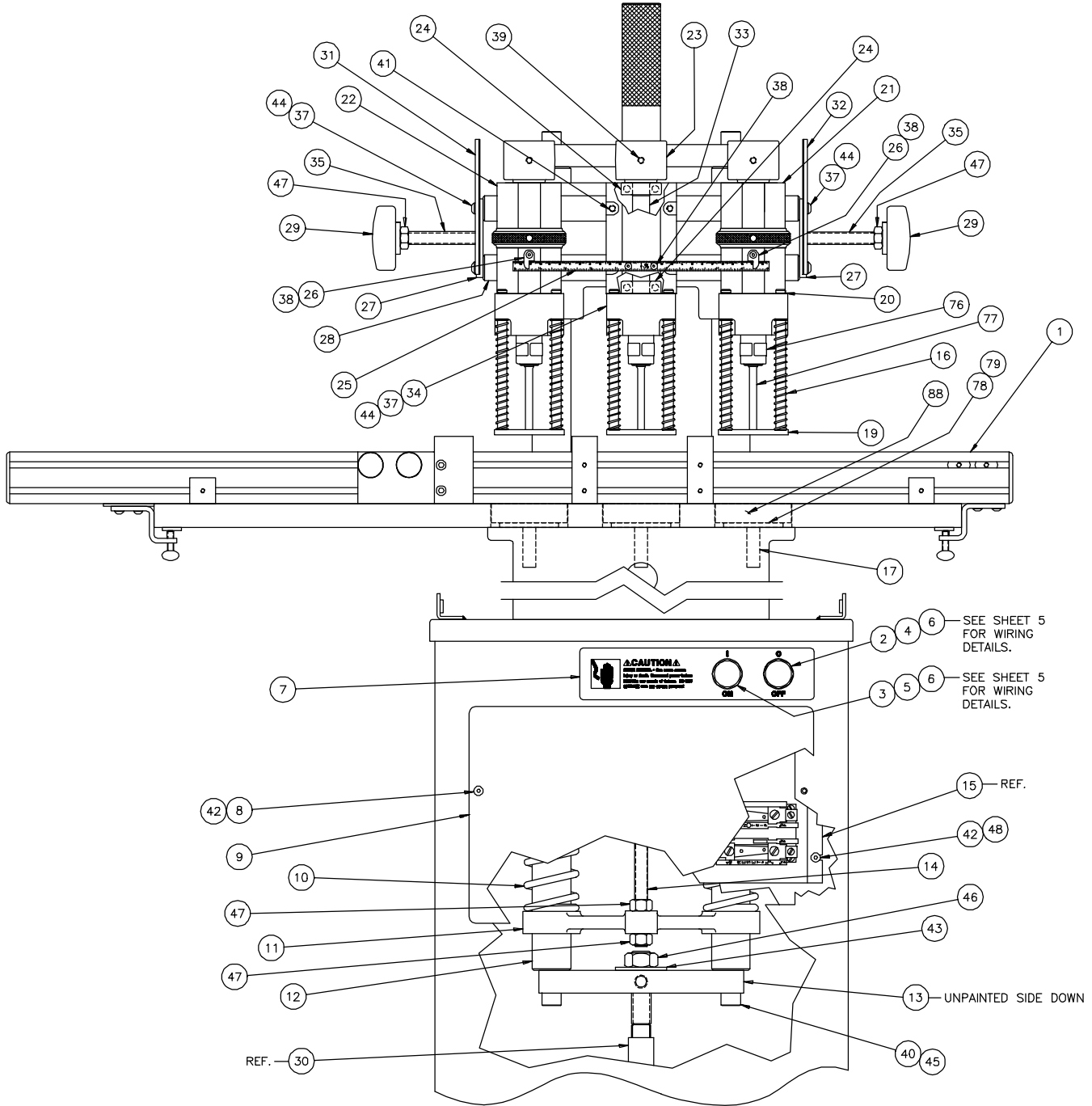

# MAIN ASSEMBLY - FRONT VIEW

## A-5846-9 SHEET 1 OF 5

NO.	PART NO.	DESCRIPTION OF ACCESSORIES	QTY
1	5700	BACKGAUGE ASM.	1
2	E-2074-1	PUSHBUTTON - OFF (RED)	1
3	E-2074	PUSHBUTTON - ON (GREEN)	1
4	E-1839-8	CONTACT BLOCK - N.C.	REF.
5	E-1839-9	CONTACT BLOCK - N.O.	REF.
6	16520	RING - ANTI ROTATION	2
7	5712	LABEL - ON/OFF	1
8	S-1864-2	CAPTIVE RETAINING DEVICE	2
9	K-480-3	FRONT GRILL	1
10	K-250-8	SPRING	2
11	K-249	LIFT SPRING BRACKET	1
12	KK-440-16	GUIDE BAR ASM	2
13	K-836-4	GUIDE ROD BRACKET	1
14	K-251-3	ROD - LIFT SPRING	1
15	EE-1635-4	POWER PANEL	REF.
16	4629-1	SPRING - PRESSURE FOOT	6
17	KK-281-2	CUT STICK KNOCK OUT	3
18			
19	A-4626-7	PRESSURE FOOT ASM.	3
20	S-1518-37	RETAINING RING	6
21	A-5847-1-5R	SPINDLE BLOCK ASM. - R.H.	1
22	A-5862-1-5R	SPINDLE BLOCK ASM. - L.H.	1
23	4693-1	PULLEY	1
24	S-706	BEARING	2
25	5859	SCALE - SPINDLE LOCATION	1
26	5858	INDICATOR	2
27	5851	PLATE - ADJUSTING SCREW	2
28	5856	SHAFT - SPINDLE BLOCK GUIDE	2
29	5710	ADJ. SCREW KNOB	2
30	16541-1	HYDRAULIC POWER UNIT ASM.	REF.
31	5716	GUARD - L.H. (S/N 975459-975460 & 975732+UP)	1
	5716-1	GUARD - L.H. (S/N 975461-975731)	
32	5717	GUARD - R.H. (S/N 975459-975460 & 975732+UP)	1
	5717-1	GUARD - R.H. (S/N 975461-975731)	
33	K-16-4	SPINDLE	1
34	K-57-19	CHIP CHUTE - CENTER	1
35	5711	ADJ. SCREW	2

NO.	PART NO.	DESCRIPTION OF ACCESSORIES	QTY
37	H-6910-406	SCREW - 1/4-20 X 3/4 BUT. HD. CAP	6
38	H-6910-63203	SCREW - #6-32 X 3/8 BUT. HD. CAP	4
39	H-6951-406	SCREW - 1/4-20 X 3/8 NYLOC SET	1
40	H-6918-814	SCREW - 1/2-13 X 1-3/4 SOC. CAP	2
41	H-6938-408	SCREW - 1/4-20 X 1/2 SOC. SET	4
42	H-6910-102403	SCREW - #10-24 X 3/8 BUT. HD. CAP	5
43	H-7321-12	WASHER - 3/4 USS FLAT	4
44	H-7327-8	WASHER - 1/4 MEDIUM LOCK	4
45	H-7327-16	WASHER - 1/2 MEDIUM LOCK	2
46	H-5239-12	NUT - 3/4 LIGHT FLEX LOCK	1
47	H-6424-8	NUT - 1/2 HEX JAM	4
48	H-7324-#10	WASHER - #10 INT. TOOTH	3

NO.	PART NO.	ADDITIONAL ACCESSORIES SHIPPED W/ MACHINE	QTY
76	K-85	COVER - DRIFT HOLE	3
77	CD-4-2-1/2	DRILL - 1/4" X 2-1/2	3
	CD-5-2-1/2	DRILL - 5/16" X 2-1/2	3
78	5841	SHIM - 26 GAGE	3
79	5841-1	SHIM - 20 GAGE	3
80	4685	DRILL CLEANER (NOT SHOWN)	1
81	4687	DRILL DRIFT (NOT SHOWN)	1
82	4688	DRILL EASE STICK (NOT SHOWN)	1
83	S-1615	CORK - FOR DRILL CLEANER (NOT SHOWN)	1
84	W-130	3/16" HEX ALLEN WRENCH (NOT SHOWN)	1
85	W-137	5/32" HEX ALLEN WRENCH (NOT SHOWN)	1
86	W-141	1/8" HEX ALLEN WRENCH (NOT SHOWN)	1
87			
88	KK-473-3	1 DOZEN WOOD DRILL BLOCKS	1
89	A-4950	HAND DRILL SHARPENER (NOT SHOWN)	1
90			

# MAIN ASSEMBLY - UPPER RIGHT VIEW

## A-5846-9 SHEET 2 OF 5

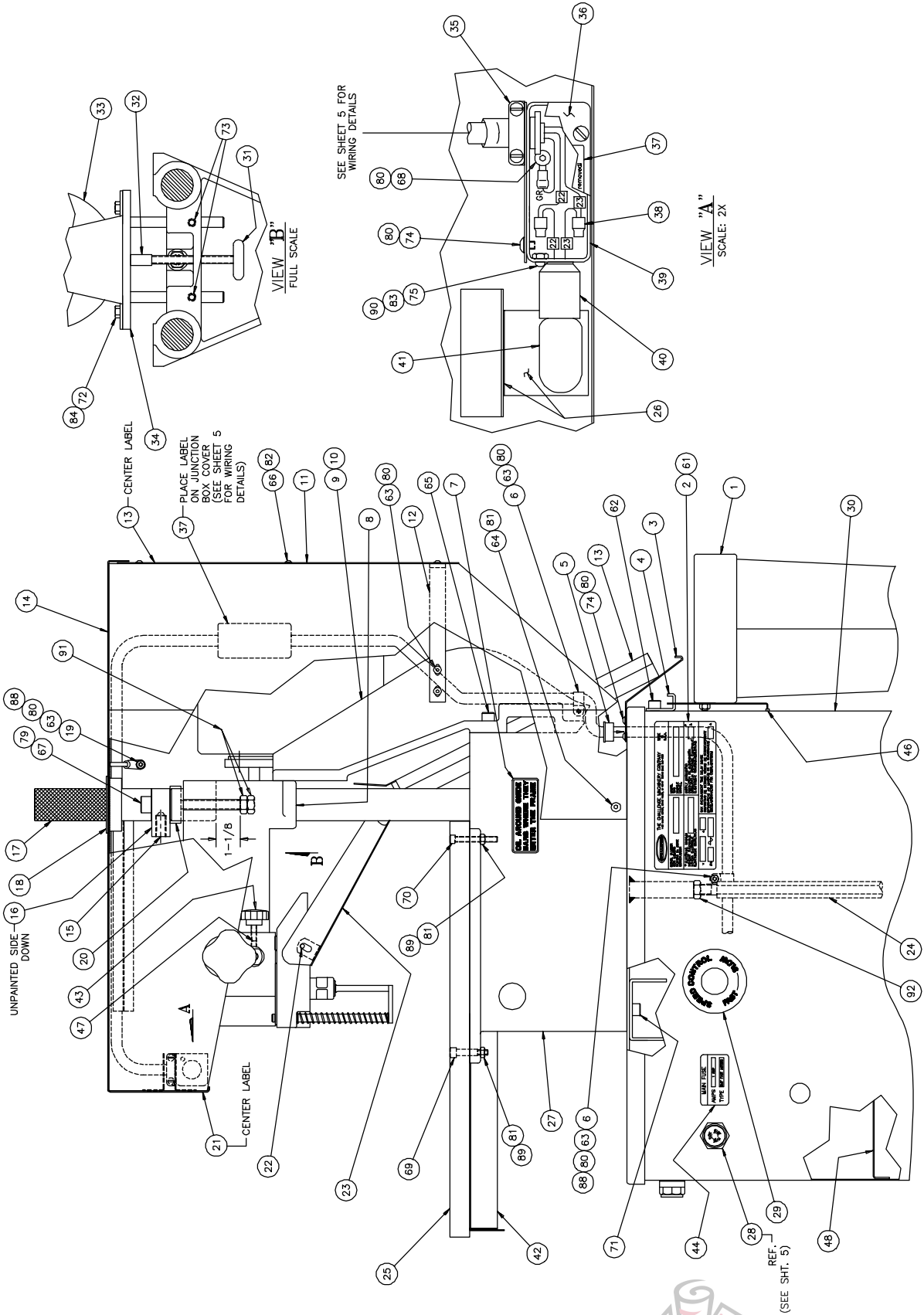

# MAIN ASSEMBLY - UPPER RIGHT VIEW

## A-5846-9 SHEET 2 OF 5

NO.	PART NO.	DESCRIPTION OF ACCESSORIES	QTY
1	A-5874	CHIP BAG ASM.	1
2	41130	SERIAL PLATE	1
3	5886	HINGE	1
4	5870	HOOK - CHIP BAG	2
5	E-1172-4	SNAP IN BUSHING	1
6	E-968-5	CLAMP - 1/2" CABLE	2
7	S-1880	LABEL - OIL	2
8	K-2-22	SPINDLE BRACKET	1
9	K-478-3	BRACE - R.H. GUIDE	1
10	K-479-4	BRACE - L.H. GUIDE	1
11	5725	BACK COVER	1
12	5733	HOOD SUPPORT	1
13	S-1781-16	LABLE - CAUTION	2
14	5720-2	HOOD ASM.	1
15	S-2021	SPRING PLUNGER	1
16	K-836-4	GUIDE ROD BRACKET	1
17	K-780-2	SPINDLE ADJ. ROD	1
18	E-1172-11	SNAP IN BUSHING	1
19	S-1694-2	TYRAP - #10	1
20	S-1818-2	THREADED COLLAR	1
21	5729	LABEL - FRONT PANEL	1
22	H-21S-187-0500	PIN - 3/16 X 1/2 ROLL	2
23	A-5878-1	CHIP CHUTE SWING ASM.	1
24	5715	JACK SCREW	1
25	KK-48-31	TABLE ASM.	1
26	S-2015	TAPE - ALUM. FOIL (3-3/4" LONG)	1
27	K-1-32	FRAME	1
28	E-2051	FUSE HOLDER ASM.	REF.

NO.	PART NO.	DESCRIPTION OF ACCESSORIES	QTY
29	S-1684	LABEL - SPEED CONTROL	1
30	KK-289-30	STAND ASM.	1
31	AA-6098	BELT ADJ. ASM.	1
32	16075	SPACER - MOTOR BELT ADJ.	1
33	E-1600-69	MOTOR - SPINDLE	1
34	KK-265-3	MOTOR BRACKET ASM.	1
35	E-913	3/8" CONDUIT CONNECTOR	1
36	E-1369-5	COVER	1
37	S-1781-11A	LABEL - CAUTION	2
38	E-1237-6	WIRE NUT	2
39	E-2249-1	JUNCTION BOX	1
40	E-964-3	SOCKET	1
41	E-933-4	CLEAR LAMP	1
42	KK-260	DRAWER ASM.	1
43	S-1602	KNOB - SPINDLE LOCK	2
44	S-1781-55	FUSE RATING LABEL	1
45			
46	7032-M	TRIM PLASTIC 1-1/2" LONG	2
47	5857	PLUG	2
48	E-1437-4	LABEL - 60 HZ	1
	E-1437-3	LABEL - 50 HZ	1
49			
50			
61	H-6924-004	SCREW - #0 X 1/4 DRIVE	2
62	H-6918-606	SCREW - 3/8-16 X 3/4 SOC. HD. CAP	2
63	H-6910-102404	SCREW - #10-24 X 1/2 BUT. HD. CAP	7
64	H-6910-404	SCREW - 1/4-20 X 1/2 BUT. HD. CAP	4
65	H-6918-610	SCREW - 3/8-16 X 1-1/4 SOC. HD. CAP	4

NO.	PART NO.	DESCRIPTION OF ACCESSORIES	QTY
66	H-6910-63204	SCREW - #8-32 X 1/2 BUT. HD. CAP	8
67	H-6918-814	SCREW - 1/2-13 X 1-3/4 SOC. HD. CAP	2
68	H-6910-102402	SCREW - #10-24 X 1/4 BUT. HD. CAP	1
69	H-5254-508	SCREW - 5/16 X 1" SHOULDER	2
70	H-5241-416	SCREW - 1/4-20 X 2" CARRIAGE	2
71	H-6918-608	SCREW - 3/8-16 X 1" SOC. HD. CAP	4
72	H-6913-504	SCREW - 5/16-18 X 1/2 HEX HD. CAP	4
73	H-6951-612	SCREW - 3/8-16 X 3/4 NYLOC SOC. SET	2
74	H-6910-102403	SCREW - #10-24 X 3/8 BUT. HD. CAP	3
75	H-6910-63202	SCREW - #8-32 X 1/4 BUT. HD. CAP	1
76			
77			
78			
79	H-7327-16	WASHER - 1/2 MED. LOCK	2
80	H-7324-#10	WASHER - #10 INT. TOOTH	11
81	H-7324-8	WASHER - 1/4 INT. TOOTH	6
82	H-7324-#8	WASHER - #8 INT. TOOTH	8
83	H-7324-#6	WASHER - #6 INT. TOOTH	1
84	H-7322-5	WASHER - 5/16" PLAIN	4
85			
86			
87			
88	H-6423-#10	NUT - #10-24 HEX	2
89	H-6423-4	NUT - 1/4-20 HEX	4
90	H-6423-#6	NUT - #6-32 HEX	1
91	H-6433-8	NUT - 1/2-13 HEX JAM. L.H. THREAD	2
92	H-6424-8	NUT - 1/2-13 HEX JAM	1

# MAIN ASSEMBLY - LOWER RIGHT VIEW

## A-5846-9 SHEET 3 OF 5

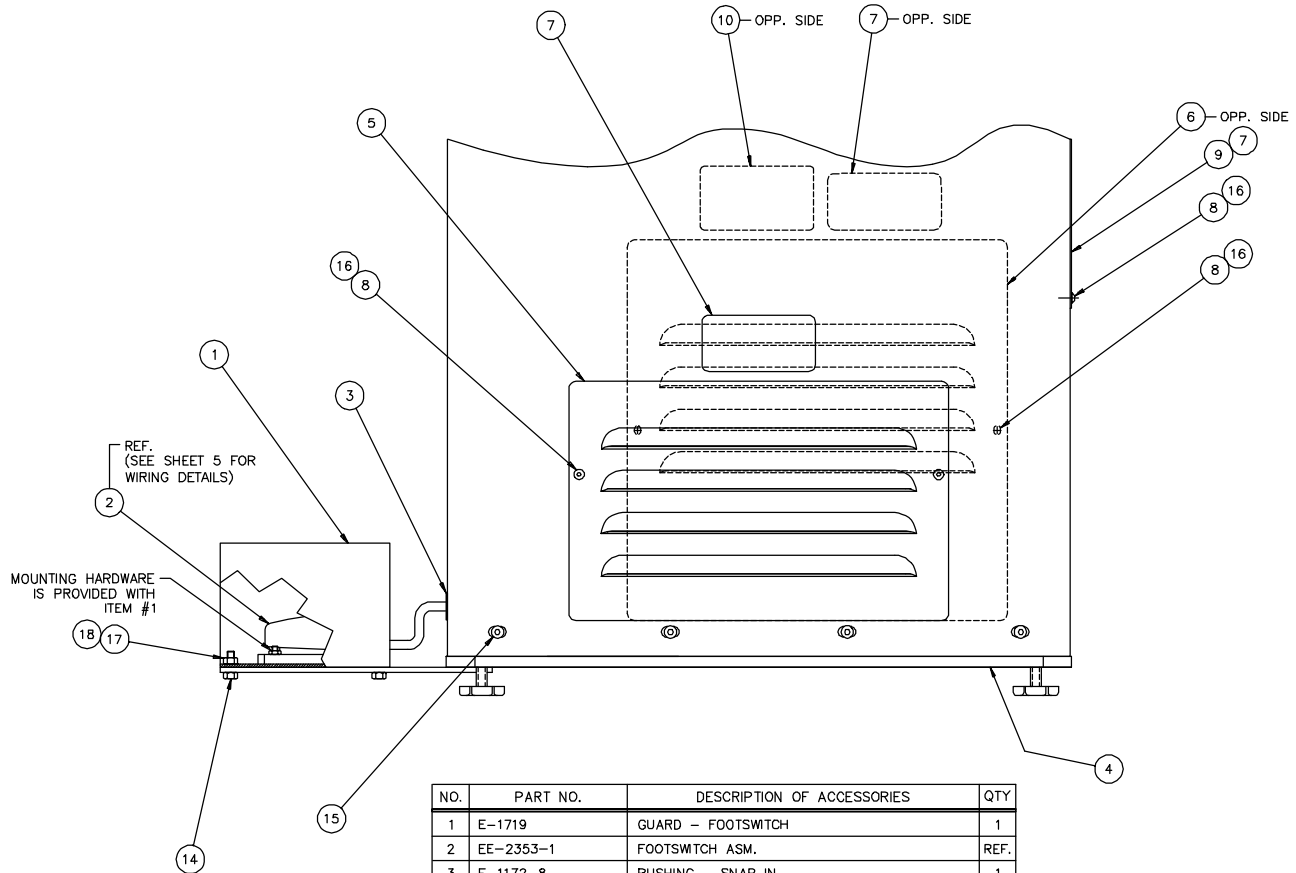

NO.	PART NO.	DESCRIPTION OF ACCESSORIES	QTY
1	E-1719	GUARD - FOOTSWITCH	1
2	EE-2353-1	FOOTSWITCH ASM.	REF.
3	E-1172-8	BUSHING - SNAP IN	1
4	16541-1	HYD. POWER UNIT ASM.	1
5	K-480-4	COVER (SERIAL NUMBERS 975731 & BELOW)	1
	K-480-1	COVER (SERIAL NUMBERS 975732 & ABOVE)	
6	K-480-2	COVER	1
7	S-1781-16	LABEL - CAUTION	3
8	S-1864-2	CAPTIVE RETAINING DEVICE	6
9	K-480-4	COVER	1
10	S-1842	LABEL - HYD. FLUID	1
11			
12			
13			
14	H-6913-406	SCREW - 1/4-20 X 3/4 HEX	4
15	H-6894-405	SCREW - 1/4-20 X 5/8 WHIZ LOCK	16
16	H-6910-102403	SCREW - #10-24 X 3/8 BUT. HD. SOC.	6
17	H-7324-8	WASHER - 1/4 INT. TOOTH	4
18	H-6423-4	NUT - 1/4-20 HEX	4

# MAIN ASSEMBLY - TOP VIEW

## A-5846-9 SHEET 4 OF 5

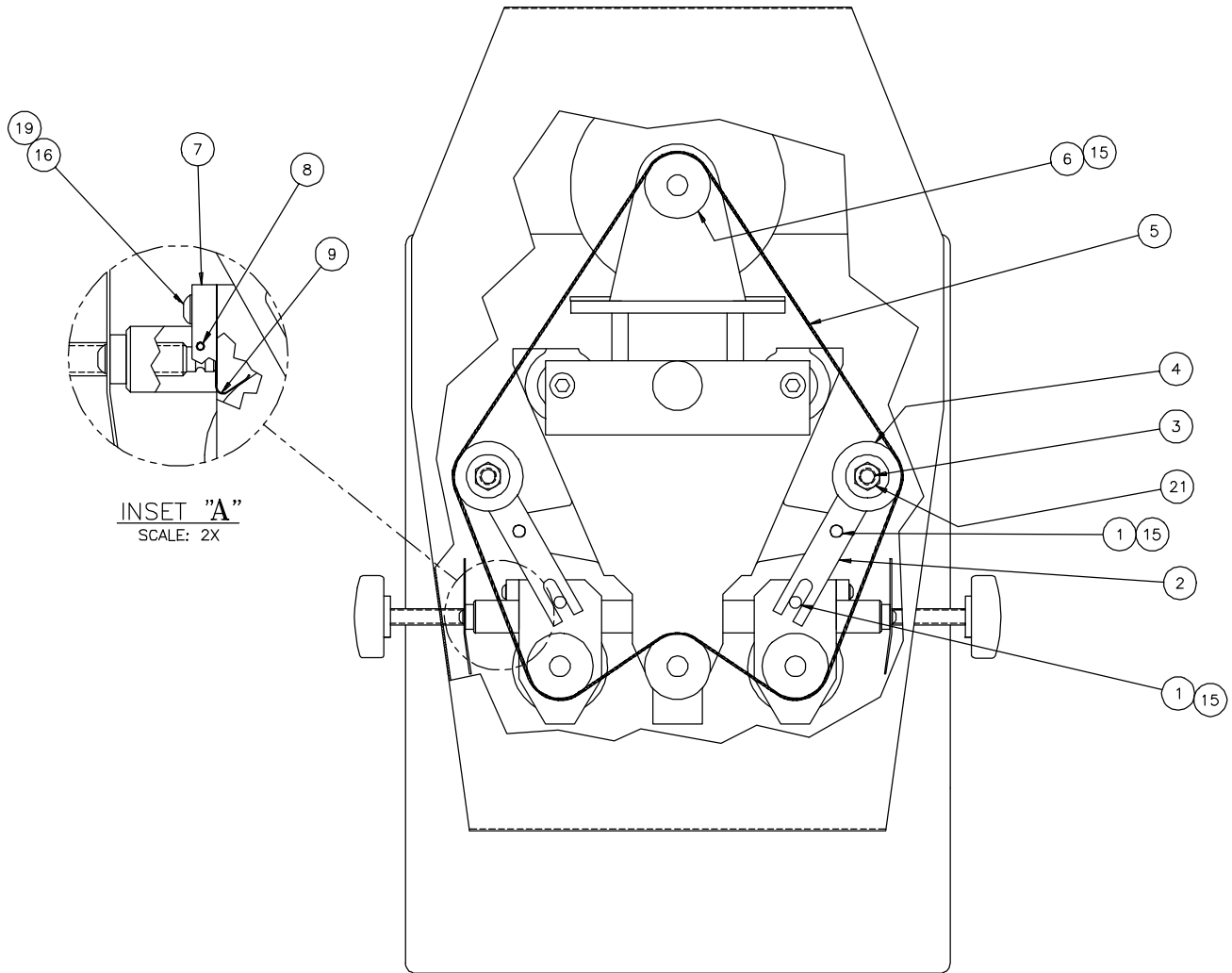

NO.	PART NO.	DESCRIPTION OF ACCESSORIES	QTY
1	5860	PIN - IDLER ARM	4
2	5861-1	ARM - IDLER PULLEY	2
3	5889	STUD - IDLER PULLEY	2
4	A-5887-1	PULLEY ASM. - IDLER	2
5	S-1661-1	BELT - FLAT	1
6	S-694-4	PULLEY - MOTOR	1
7	5852	BLOCK - ADJUSTING SCREW	2
8	H-21S-125-1000	PIN - 1/8 X 1" ROLL	2
9	4692	SPRING - SPINDLE LOCK	2
10			
11			
12			
13			
14			
15	H-6951-406	SCREW - 1/4-20 X 3/8 NYLOC SOC. SET	1
16	H-6910-406	SCREW - 1/4-20 X 3/4 BUT. HD	4
17			
18			
19	H-7327-8	WASHER - 1/4 MEDIUM LOCK	4
20			
21	H-6424-8	NUT - 1/2-13 HEX JAM	2

# MAIN ASSEMBLY - WIRING A-5846-9 SHEET 5 OF 5

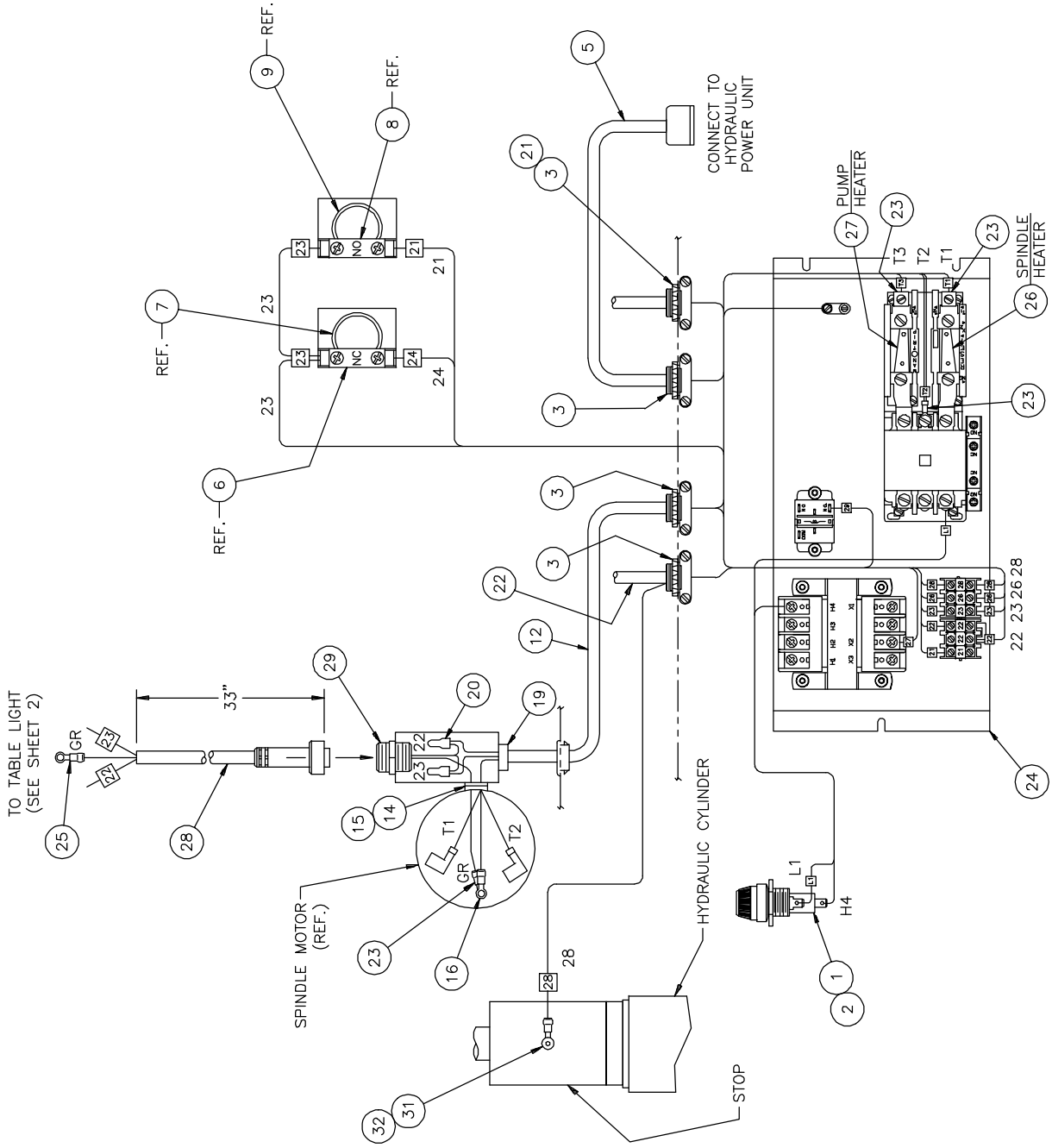

# MAIN ASSEMBLY - WIRING A-5846-9 SHEET 5 OF 5

NO.	PART NO.	DESCRIPTION OF ACCESSORIES	QTY
1	EE-2051-1	FUSE HOLDER ASSEMBLY	1
2	E-1075-1	FUSE - 1 AMP FAST-ACTING	1
3	E-894	CORD GRIP	4
4			
5	EE-1363-2	CONNECTOR ASSEMBLY	1
6	E-1839-8	CONTACT BLOCK - N.C.	REF.
7	E-2074-1	PUSHBUTTON - OFF (RED)	REF.
8	E-1839-9	CONTACT BLOCK - N.O.	REF.
9	E-2074	PUSHBUTTON - ON (GREEN)	REF.
10			
11			
12	EE-1650-1	WIRE ASSEMBLY - TABLE LIGHT	1
13			
14	H-7324-28	WASHER - 7/8" SHAKEPROOF LOCK	1
15	E-1458	NIPPLE - 1/2" BUSHED CONDUIT	1
16	S-1099-3	SCREW - #10-24 x 3/8 PAN HD SELF-TAP	1
17	E-1370-5	JUNCTION BOX	1
18	E-1369-5	COVER - JUNCTION BOX	1
19	S-1350-1	BUSHING - HEYCO	1
20	E-1237-1	WIRE NUT	2
21	EE-2353-1	FOOTSWITCH ASSEMBLY	1
22	EE-2354-1	CABLE ASSEMBLY - SOLENOID	1
23	E-1214-1	CONNECTOR - INS. LOCKING FORK	4
24	EE-1635-4	POWER PANEL ASSEMBLY	1
25	E-1214-48	CONNECTOR - #10 INS. RING	3
26	E-2195-E44	HEATER - SPINDLE (5.32 TRIP AMP) - 50 HZ	1
27	E-2195-E47	HEATER - SPINDLE (6.37 TRIP AMP) - 60 HZ	1
28	E-2195-E41	HEATER - HYDRAULIC (4.26 TRIP AMP) 50 HZ	1
29	E-2195-E42	HEATER - HYDRAULIC (4.77 TRIP AMP) 60 HZ	1
30	E-2451-4	CABLE ASM W/ CONNECTOR	1
31	E-2450-2	CABLE CONNECTOR PIGTAIL	1
32	H-6910-102403	SCREW - #10-24 X 3/8 BUT. HD. CAP	1
33	H-7324-#10	WASHER - #10 INT. TOOTH	1

## WIRING ASSEMBLY / SCHEMATIC

208 VOLT 1 PHASE 60 HZ  
230 VOLT 1 PHASE 60 HZ  
230 VOLT 1 PHASE 50 HZ

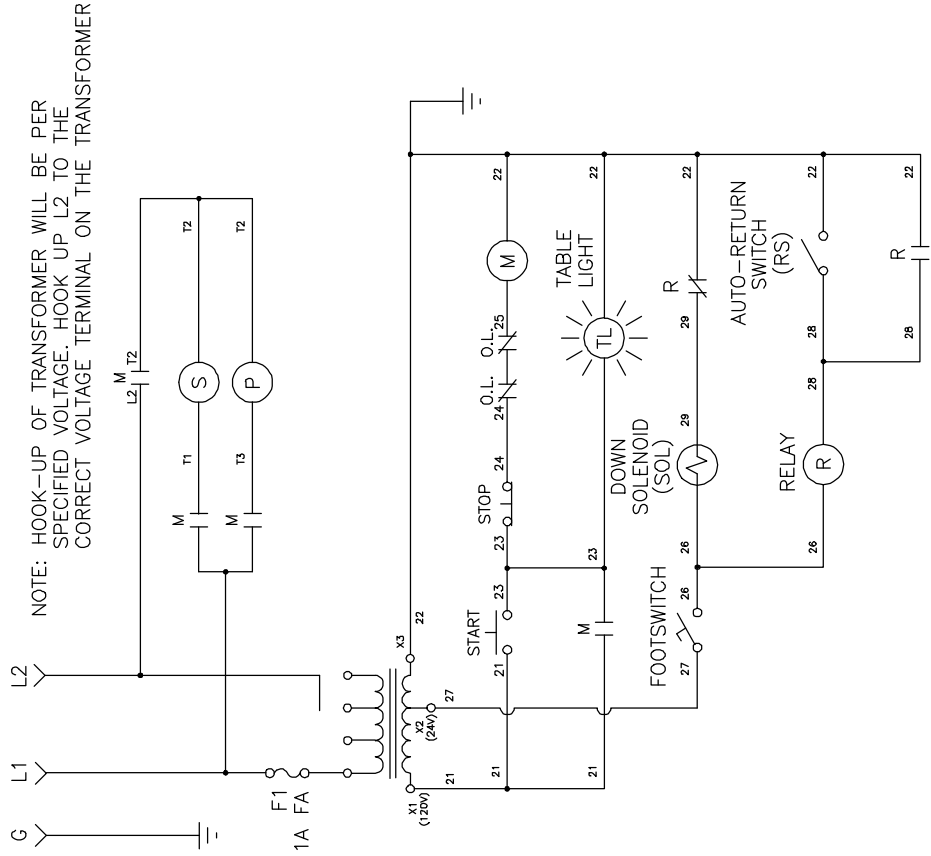



# ELECTRICAL POWER PANEL ASSEMBLY EE-1635-4

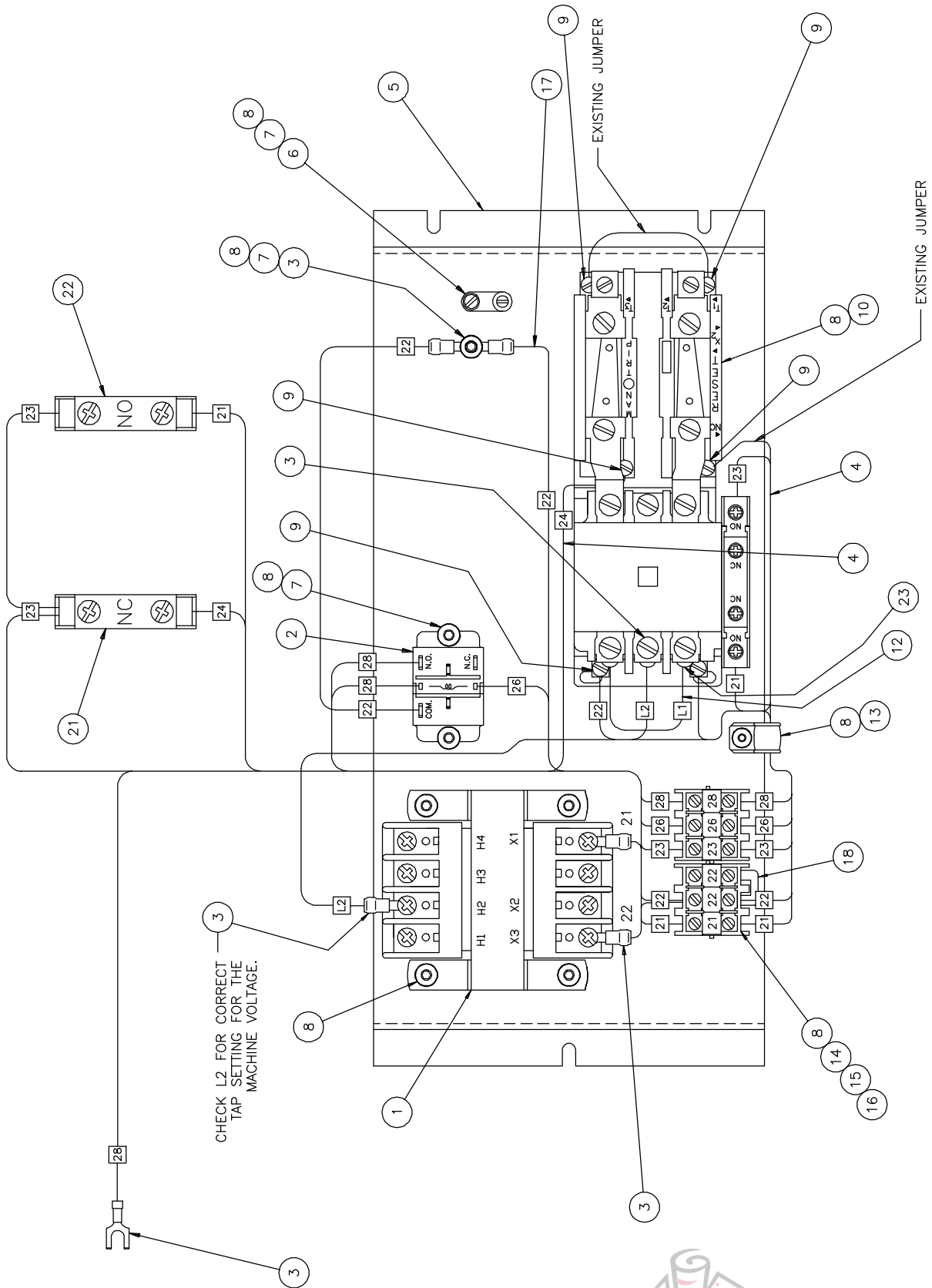

## ELECTRICAL POWER PANEL ASSEMBLY EE-1635-4

NO.	PART NO.	DESCRIPTION OF ACCESSORIES	QTY
1	E-1089-40	TRANSFORMER, 75VA - 208/230/460V	1
2	E-2232-1	RELAY	1
3	E-1214-59	CONNECTOR, #10 INS. FORK, 16-22 GA.	6
4	E-709-R	WIRE, #18 GA. RED MTW (AS REQ'D)	18ft
5	E-1052-10	PANEL - ELECTRICAL	1
6	E-640-1	GROUND LUG	1
7	H-7324-#10	WASHER, #10 SHAKEPROOF	3
8	H-6910-102403	SCREW, #10-24 X 3/8 BUT HD	12
9	E-1214-4	CONNECTOR, #6 INS. LOCKING FORK	5
10	E-2194-1	STARTER - MOTOR	1
11	H-7324-#6	WASHER - #6 INT. TOOTH	3
12	E-849-R	WIRE, #16 GA. RED MTW 6" LONG	1
13	E-968-4	CABLE CLAMP	1
14	E-1271	MOUNTING RAIL - 2-1/2" LONG	1
15	E-1270	TERMINAL BLOCK - 3 POLE	2
16	E-1356-115	MARKING STRIP - TERMINAL BLOCK	1
17	E-849-G	WIRE, #16 GA. GREEN MTW 10-1/2" LONG	1
18	E-1355-1	JUMPER - TERMINAL BLOCK	1
19	E-1214-65	CONNECTOR - 1/4 FULLY INS. Q.D.	2
20	E-1214-51	CONNECTOR - 3/16 FULLY INS. Q.D.	2
21	E-1839-8	CONTACT BLOCK - N.C.	1
22	E-1839-9	CONTACT BLOCK - N.O.	1
23	E-1214-10	CONNECTOR - #6 INS. RING	3
24			
25			

# HYDRAULIC/BASE ASSEMBLY 16541-1

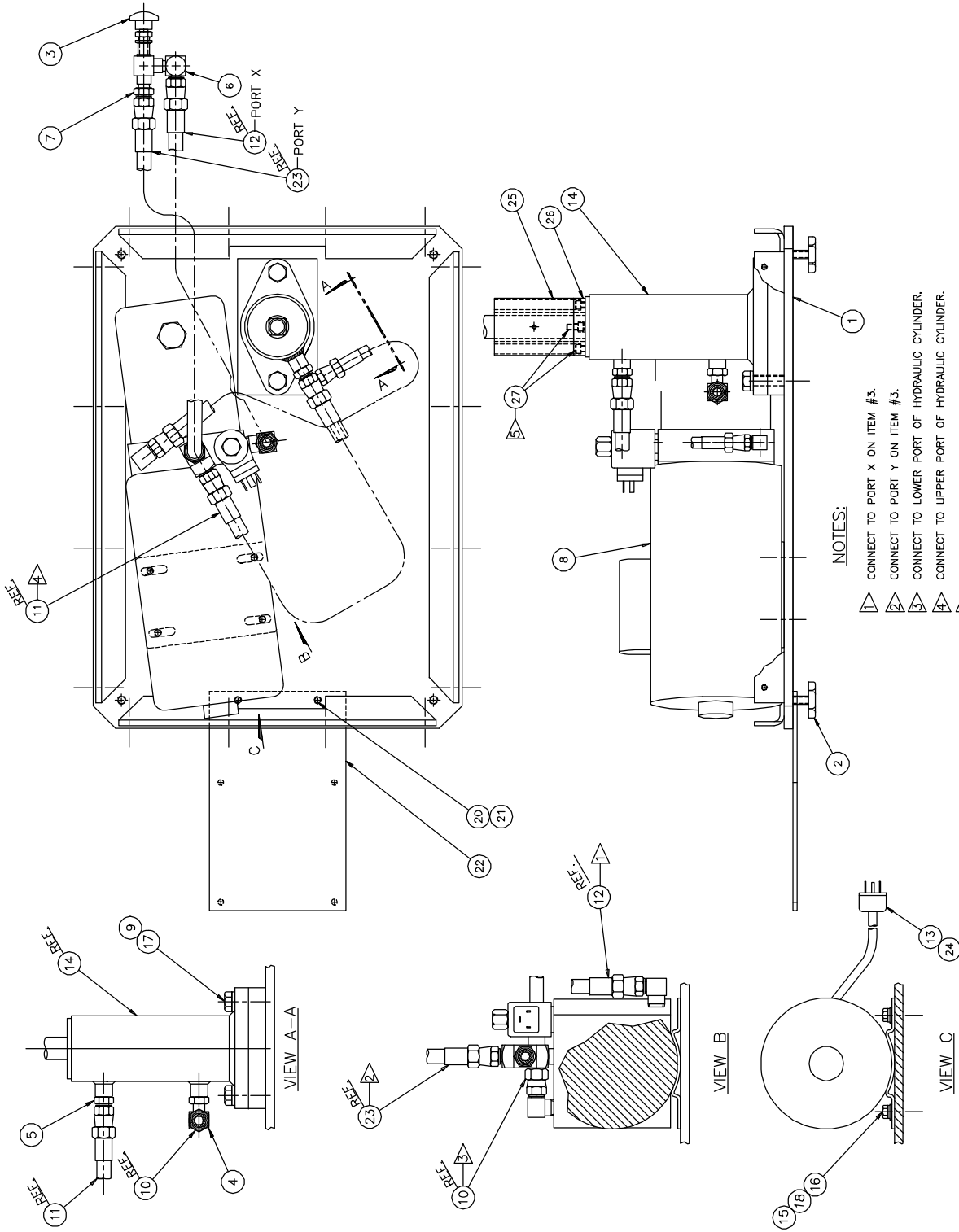

**NOTES:**

- △ CONNECT TO PORT X ON ITEM #3.
- △ CONNECT TO PORT Y ON ITEM #5.
- △ CONNECT TO LOWER PORT OF HYDRAULIC CYLINDER.
- △ CONNECT TO UPPER PORT OF HYDRAULIC CYLINDER.
- △ REMOVE EXISTING SCREWS IN CYLINDER COVER & REPLACE WITH ITEM #27. LOC-TITE SCREWS IN PLACE WITH BLUE LOC-TITE.

# HYDRAULIC/BASE ASSEMBLY 16541-1

NO.	PART NO.	DESCRIPTION OF ACCESSORIES	QTY
1	16540	WELDMENT - POWER PACK BASE	1
2	16543	FOOT - BASE	4
3	4771-1	VALVE - NEEDLE	1
4	H-230-5	ELBOW - 7/16 O-RING TO 7/16 TUBE	1
5	H-236-5	ADAPTER - 7/16 O-RING TO 9/16 TUBE	1
6	H-237-5	ELBOW - 1/8 NPT TO 9/16 TUBE	1
7	H-241-5	ADAPTER - 1/8 NPT TO 9/16 TUBE	1
8	H-356-2	HYD. POWER UNIT - 115/208/230V 50/60C 1PH	1
9	H-7327-16	LOCKWASHER - 1/2 MEDIUM	2
10	H-242-32	HOSE ASSEMBLY - 18" LONG	REF.
11	H-242-2	HOSE ASSEMBLY - 15" LONG	REF.
12	H-242-42	HOSE ASSEMBLY - 30" LONG	REF.
13	EE-2555	CORD ASSEMBLY - POWER PLUG	1
14	H-340	CYLINDER - HYDRAULIC	1
15	H-7327-10	LOCKWASHER - 5/16 MEDIUM	4
16	H-6913-505	SCREW - 5/16-18 X 5/8 HEX	4
17	H-6913-812	SCREW - 1/2-13 X 1-1/2 HEX	2
18	H-7321-5	WASHER - 5/16 PLAIN	4
19			
20	H-7327-8	WASHER - 1/4 MED. LOCK	2
21	H-6910-406	SCREW - 1/4-20 X 3/4 BUTT. HD.	2
22	16542	BRACKET - FOOTSWITCH	1
23	H-242-41	HOSE ASSEMBLY - 25" LONG	REF.
24	E-1237-6	WIRE NUT	2
25	5718	STOP	1
26	5719	ISOLATOR	1
27	H-6918-405	SCREW - 1/4-20 X 5/8 SOC. HD. CAP	4

## HYDRAULIC SCHEMATIC

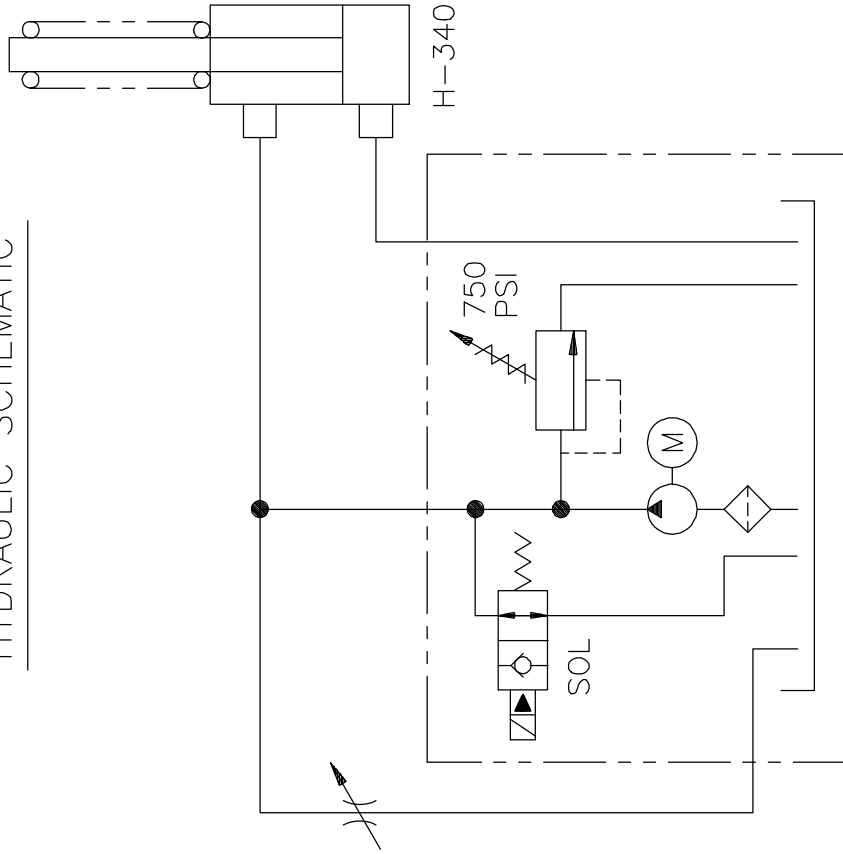

# HYDRAULIC POWER UNIT ASSEMBLY H-356-2

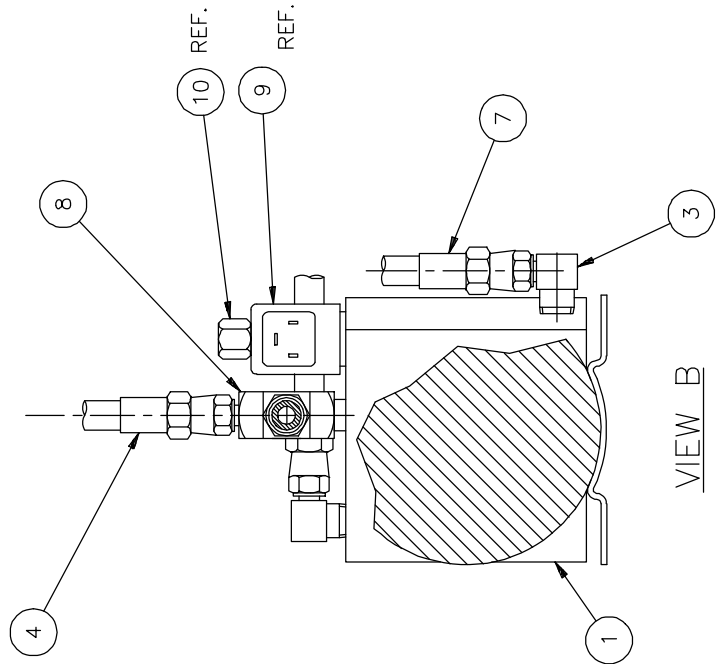
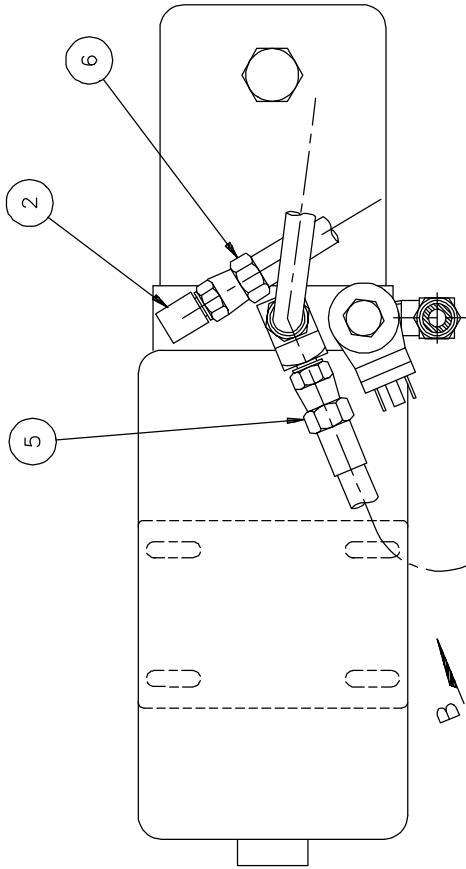

NO.	PART NO.	DESCRIPTION OF ACCESSORIES	QTY
1	H-372-3	HYD. POWER UNIT - 115/208/230V 50/60C 1PH	1
2	H-237-3	ELBOW - 3/8-18 NPT X 7/16-20 TUBE	1
3	H-237-4	ELBOW - 1/4 NPT X 9/16-18 TUBE	1
4	H-242-41	HOSE ASSEMBLY - 25" LONG	1
5	H-242-2	HOSE ASSEMBLY - 15" LONG	1
6	H-242-32	HOSE ASSEMBLY - 18" LONG	1
7	H-242-42	HOSE ASSEMBLY - 30" LONG	1
8	H-263-2	TEE - 3/8-18 NPT X 9/16-18 TUBE	1
9	E-1069-17	24 V. COIL	REF.
10	H-200-5	CARTRIDGE SOLENOID	REF.

# HYDRAULIC POWER UNIT H-372-2 (S/N 975459 to 975739)

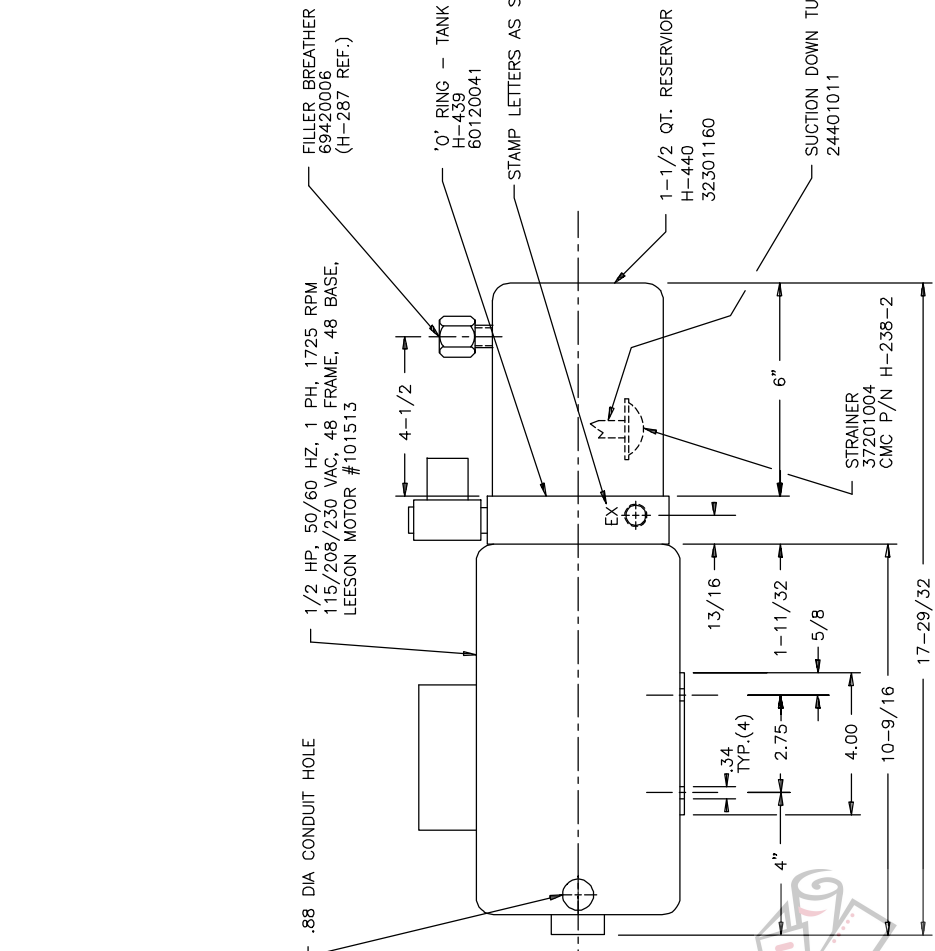
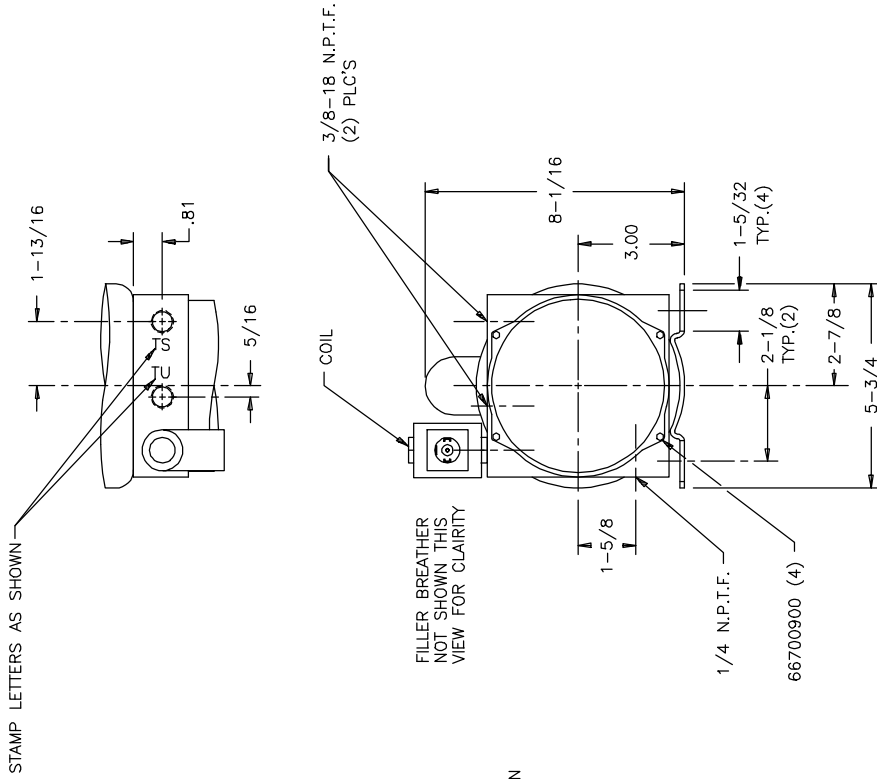

- REPAIR PARTS**
- E-1600-43 ELECTRIC MOTOR (115/208/230 VAC)
  - E-1069-17 24V COIL
  - H-200-5 CARTRIDGE - SOLENOID (NOT SHOWN)
  - HH-299-14 SEAL KIT
  - H-451 PUMP KIT
  - H-440 TANK - 1-1/2qt RESERVOIR
  - H-439 'O' RING - TANK
  - H-238-2 STRAINER
  - H-287 FILLER/BREATHER
- PUMP SPECS:**
- .263 C.I.R.
  - (1.96 G.P.M. THEORETICAL)
  - (APPROX. 1.8 ACTUAL)
- MFR.: DTS FLUID POWER**  
**MFR. PART NO.: HFP-2011**

# HYDRAULIC POWER UNIT H-372-3 (S/N 975740 & UP)

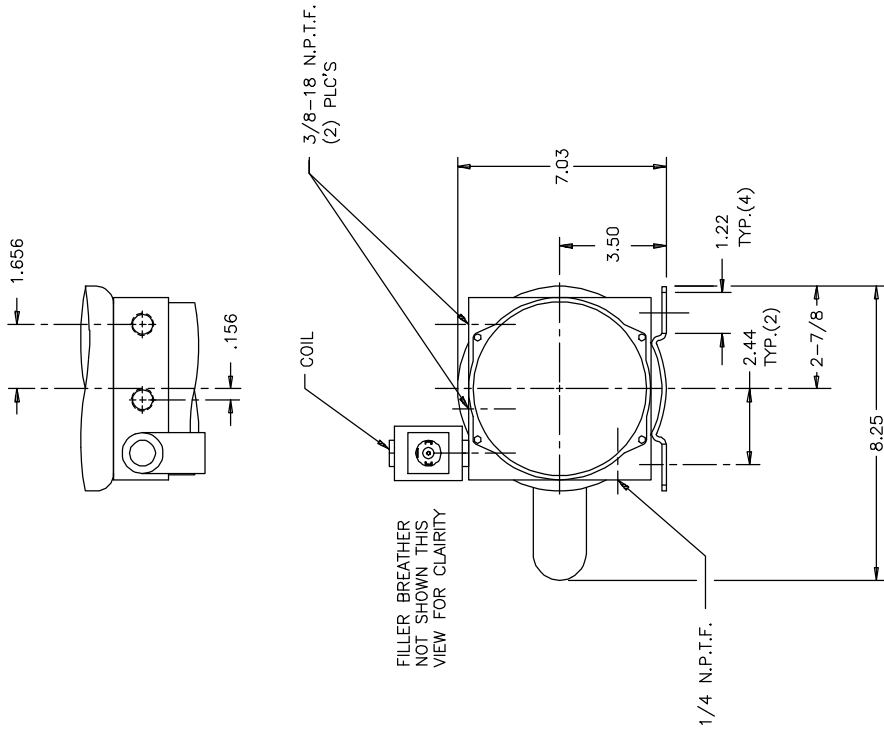

PUMP SPECS:  
??? C.I.R.  
(??? G.P.M. THEORETICAL)  
(APPROX. ??? ACTUAL)

MFR.: FENNER  
MFR. PART NO.: 84379A

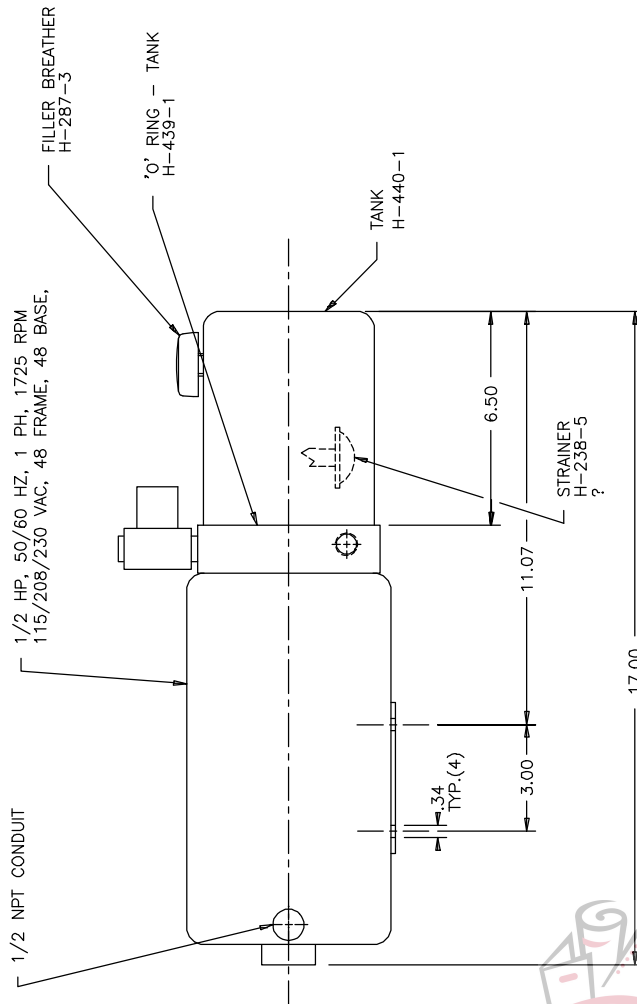

REPAIR PARTS

- E-1069-17 24 V. COIL
- H-200-5 CARTRIDGE - SOLENOID (NOT SHOWN)
- HH-299-23 SEAL KIT
- H-451-1 PUMP KIT
- H-440-1 TANK
- H-439-1 O'RING - TANK
- H-238-5 STRAINER
- H-287-3 FILLER/BREATHER

## TABLE ASSEMBLY KK-48-31 REV. H

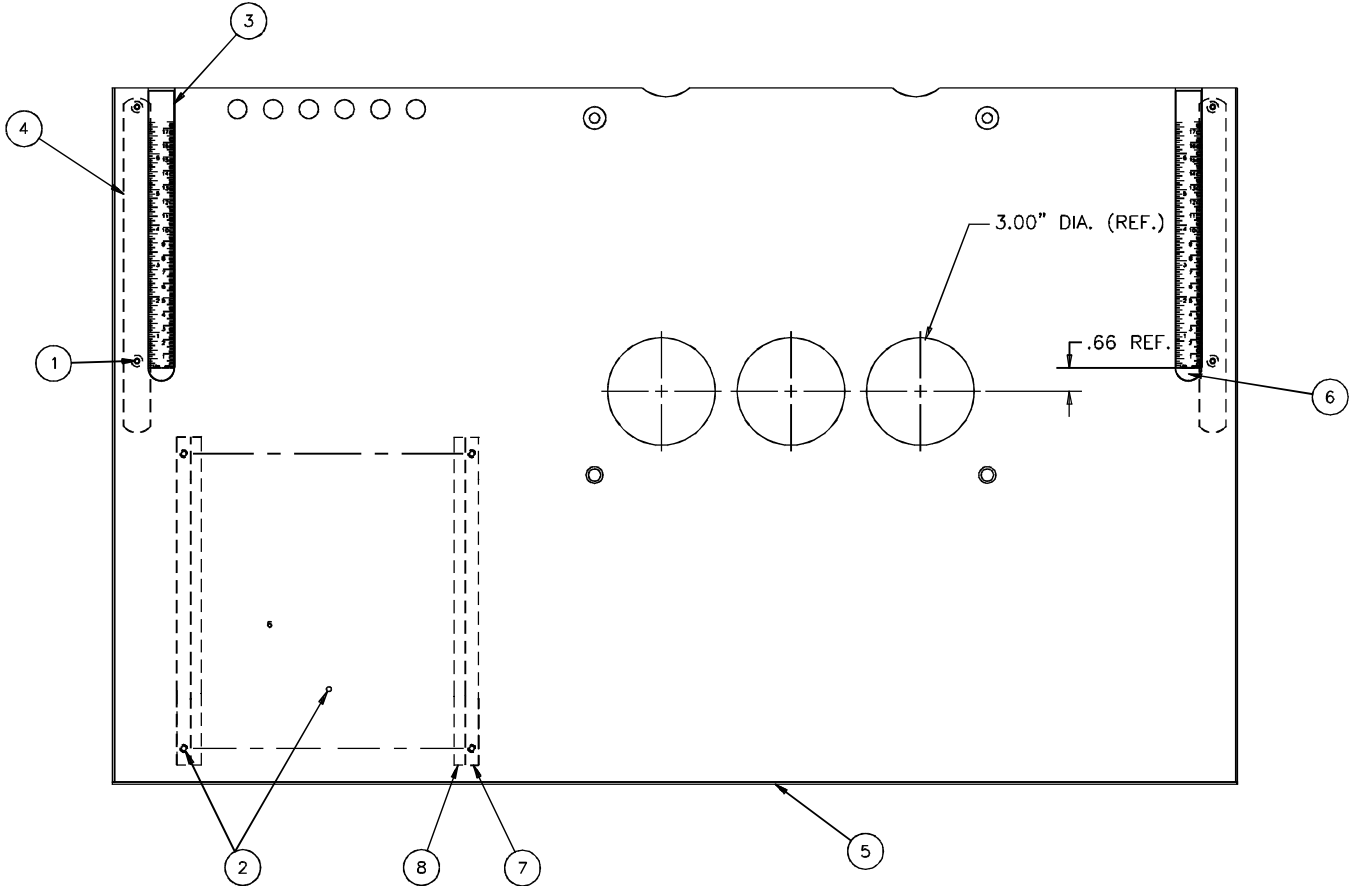

NO.	PART NO.	DESCRIPTION OF ACCESSORIES	QTY
1	H-6961-605	#6 X 5/8 F.H. WOODSCREW	8
2	H-6962-1006	#10 X 3/4 R.H. WOODSCREW	6
3	4636-2	SCALE	2
4	K-93-2	TABLE SIDE STRIP	2
5	K-46-30	TABLE	1
6	S-1792	1/2 X .19 WIRE NAILS	8
7	16500	DRAWER GUIDE COVER	4
8	16501	DRAWER GUIDE FILLER	2



# BACKGAUGE ASSEMBLY 5700

ASM. TOOL DETAIL

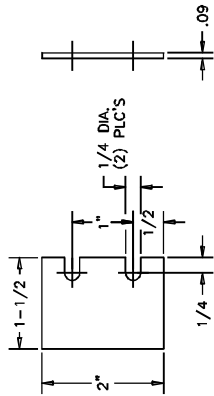

INSET A  
SCALE: 3X

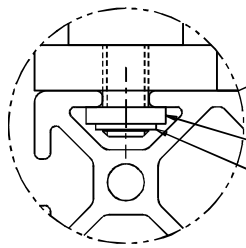

SHOULDER  
INSERT T-NUT  
(ITEM #4) WITH  
SHOULDER IN  
POSITION SHOWN

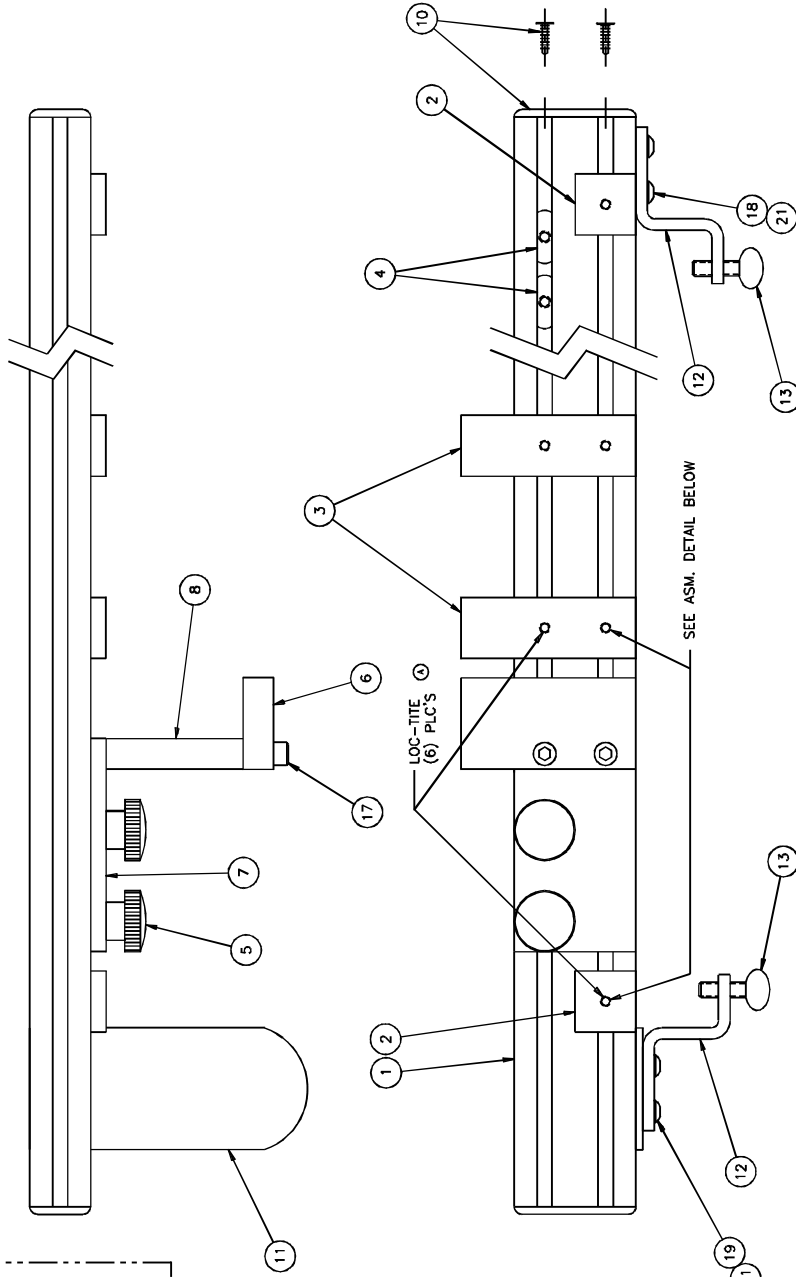

NOTES:

- 1 WITH ASM. TOOL IN PLACE AS SHOWN, TURN IN SCREW UNTIL SPRING COMPRESSES COMPLETELY, THEN BACK OFF SCREW 1/4 TURN.
- 2 LINE UP THE SLOTS ON THE ASM. TOOL WITH THE SLOTS ON THE BACKGAUGE AND SLIDE THE SPACER ASSEMBLY (ITEM #2 OR ITEM #3) ONTO THE BACKGAUGE.

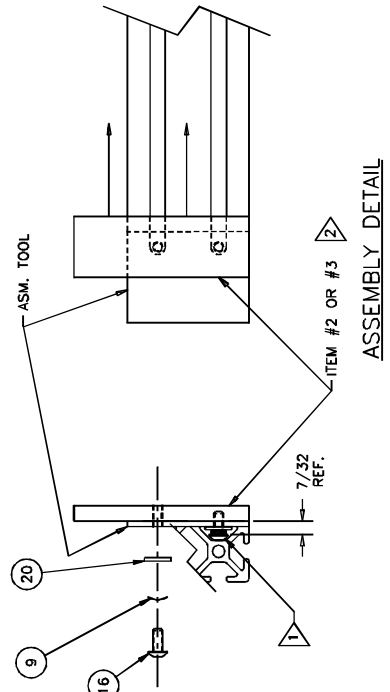

## BACKGAUGE ASSEMBLY 5700

NO.	PART NO.	DESCRIPTION OF ACCESSORIES	QTY
1	5701	BACKGAUGE	1
2	5706	BACKGAUGE SCALE SPACER	2
3	5705	BACKGAUGE SPACER	2
4	5708-1	T-NUT - #10-32	8
5	8278-1	KNIURLED KNOB	2
6	5704	SIDEGUIDE	1
7	5703	SIDEGUIDE PLATE	1
8	5702	SIDEGUIDE EXTENSION	1
9	11115	SPRING WASHER	6
10	5707	END CAP W/PLUGS	2
11	4794	BACKGAUGE GUIDE PLATE	1
12	4655	BACKGAUGE CLAMP	2
13	H-6955-508	THUMBSCREW - 5/16-18 X 1"	2
14			
15			
16	H-6910-83203	SCREW - #8-32 X 3/8 BUT. HD.	6
17	H-6918-424	SCREW - 1/4-20 X 3" SOC. HD. CAP	2
18	H-6920-103204	SCREW - #10-32 X 1/2 BUT. HD.	2
19	H-6920-103205	SCREW - #10-32 X 5/8 BUT. HD.	2
20	H-7321-#8	WASHER - #8 PLAIN	6
21	H-7324-#10	WASHER - #10 INT. TOOTH	4

# OPTIONAL AUTO-TRIP BACKGAUGE ASSEMBLY

A-4615-9

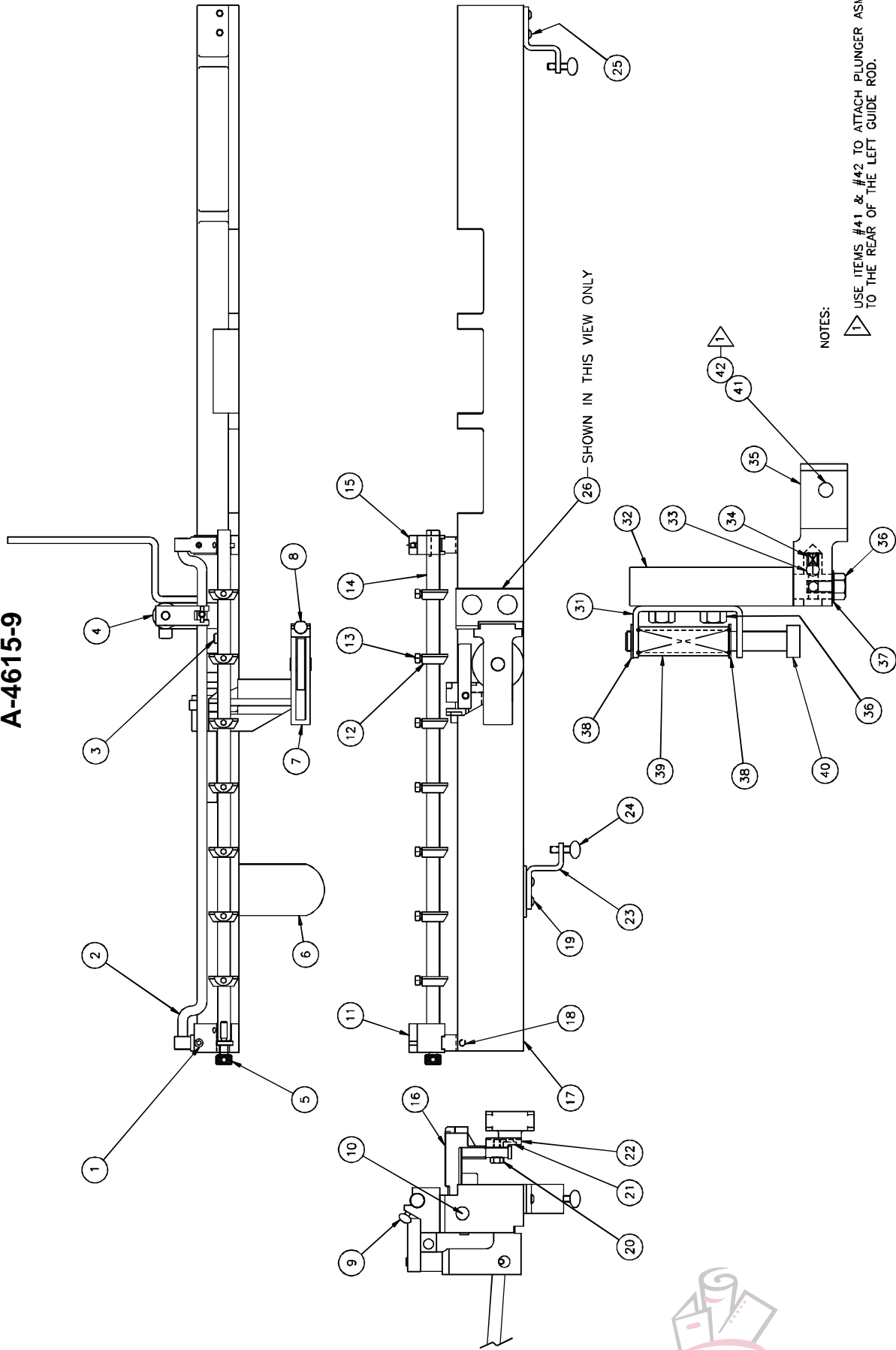

NOTES:

1 USE ITEMS #41 & #42 TO ATTACH PLUNGER ASM. TO THE REAR OF THE LEFT GUIDE ROD.

PLUNGER ASM.  
SCALE: 2X

## OPTIONAL AUTO-TRIP BACKGAUGE ASSEMBLY A-4615-9

NO.	PART NO.	DESCRIPTION OF ACCESSORIES	QTY
1	H-6918-102408	#10-24NCX1 SOC HD CAP SCREW	2
2	KK-695-8	S.G. LATCH LIFT SHAFT ASSEM.	1
3	H-6918-406	1/4-20 NC X3/4 SOC HD CAP SCREW	1
4	KK-411-8	ASSEM. SIDE GUIDE LATCH ARM	1
5	4632	S.G. SHAFT ADJUSTING SCREW	1
6	4794	REAR GAUGE GUIDE PLATE	1
7	A-4785	ASSEM. SIDE GUIDE ROLLER	1
8	A-4791-1	SIDE GUIDE FACE ASSEM.	1
9	H-6955-404	1/4 X 1/2 PLATED THUMBSCREW	2
10	4792-1	REAR GAUGE SHAFT	1
11	4799	SIDE GUIDE SHAFT BRKT..LH	1
12	4654	SIDE GUIDE STOP	7
13	H-6940-408	1/4-20 X 1/2 FL PT SOC SET SCREW	7
14	4633-1	SIDE GUIDE SHAFT	1
15	4634	INDEX ROD HOLDER	1
16	A-4787	SIDE GUIDE ASSEM.	1
17	4776-8	REAR GAUGE	1
18	H-6938-408	1/4-20 NC X 1/2 SET SCREW	1
19	H-6918-405	1/4 X 5/8 SOC. HD. CAP. SCREW	2
20	H-6913-405	1/4 X 5/8 HEX HEAD CAP SCREW	1
21	H-6910-404	1/4-20 X 1/2 BUTTON HD CAP.SCREW	1
22	4827-1	SHIM FOR SIDE GUIDE	1
23	4655	BACK GAUGE CLAMP	2

NO.	PART NO.	DESCRIPTION OF ACCESSORIES	QTY
24	H-6955-508	5/16-18 NC X 1 THUMB SCREW	2
25	H-6918-404	1/4-20 NC X 1/2 SOC. HD. CAP. SCREW	2
26	A-4728-1	SIDE GUIDE EXTENSION	1
27			
28			
29			
30			
31	K-700-3	SIDE GUIDE TRIP PLUNGER HOLDER	1
32	K-702-4	SIDE GUIDE LATCH LIFT SPACER	1
33	S-766	1/4 STEEL BALL	1
34	K-694-1	LATCH SIDE SPRING	1
35	KK-458-2	ASSEM. GUIDE ROD ARM	1
36	H-6913-404	1/4 X 1/2 PLATED CAP SCREW	3
37	H-7322-4	1/4 POLISHED WASHER	1
38	S-1193-37	RETAINING RING	2
39	K-701-2	SIDE GUIDE TRIP PLUNGER SPRING	1
40	K-697	SIDE GUIDE TRIP PLUNGER	1
41	H-6913-406	1/4-20 X 3/4 HEX HEAD SCREW	1
42	H-7324-8	1/4 INT. TOOTH LOCKWASHER	1

## SPINDLE HEAD ASSEMBLY, RIGHT HAND A-5847-1-5-R

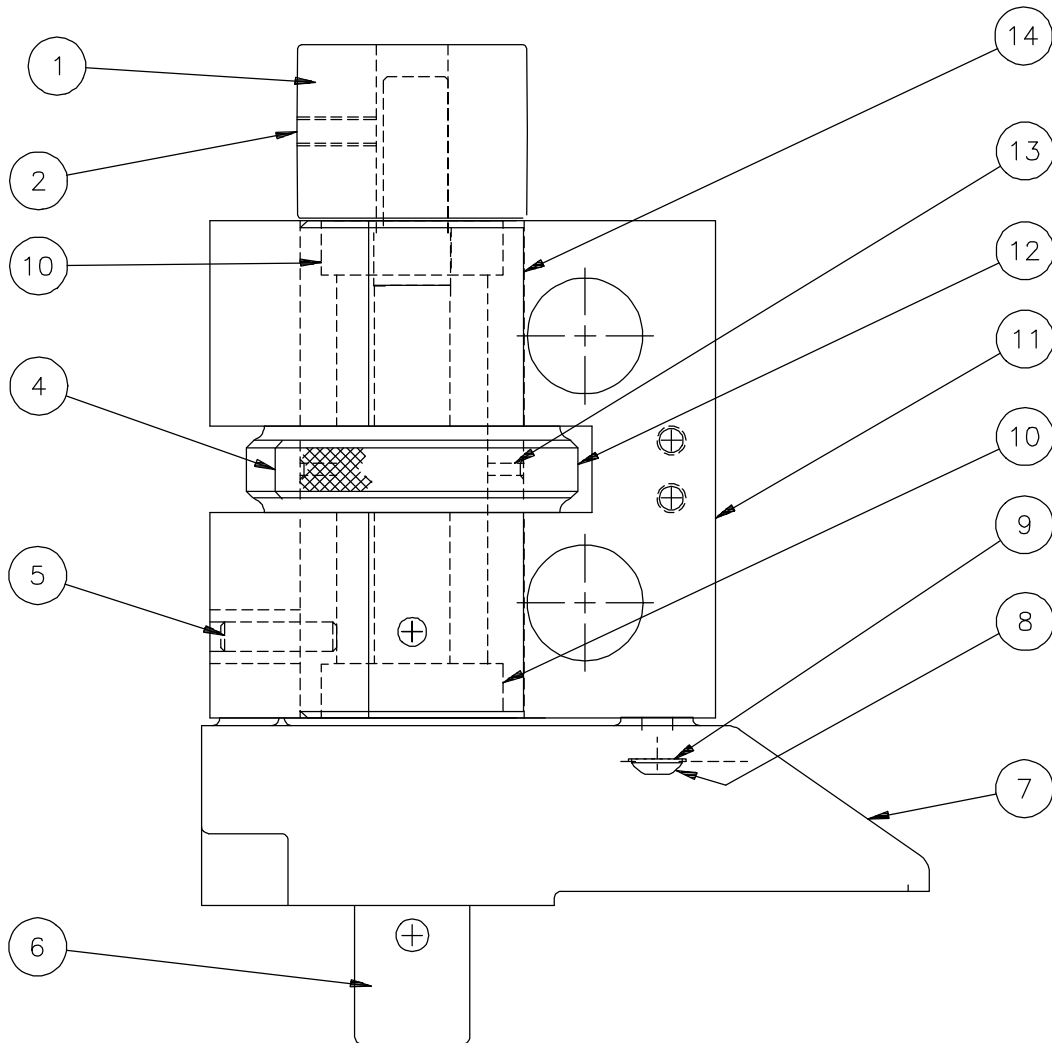

NO.	PART NO.	DESCRIPTION OF ACCESSORIES	QTY
1	4693-1	CROWNED PULLEY	1
2	H-6951-406	1/4 X 3/8 SOCKET SET SCREW(NYLOK)	1
3			
4	5854	COLLAR - BEARING HOUSING	1
5	H-5246-408	1/4 - 1 DOWEL PIN	1
6	K-16-4	SPINDLE	1
7	5872-2	CHIP CHUTE RH	1
8	H-6910-406	1/4 X 3/4 BUT HD CAP SCREW	2
9	H-7327-8	1/4 MED LOCK WASHER	2
10	S-706	6693 BALL BEARING	2
11	5848-1-5	SPINDLE BLOCK RH	1
12	5855-1	ADJUSTMENT NUT	1
13	H-5246-204	1/8 X 1/2 DOWEL PIN	2
14	5853	SLEEVE - BEARING HOUSING	1

## SPINDLE HEAD ASSEMBLY, LEFT HAND A-5862-1-5-R

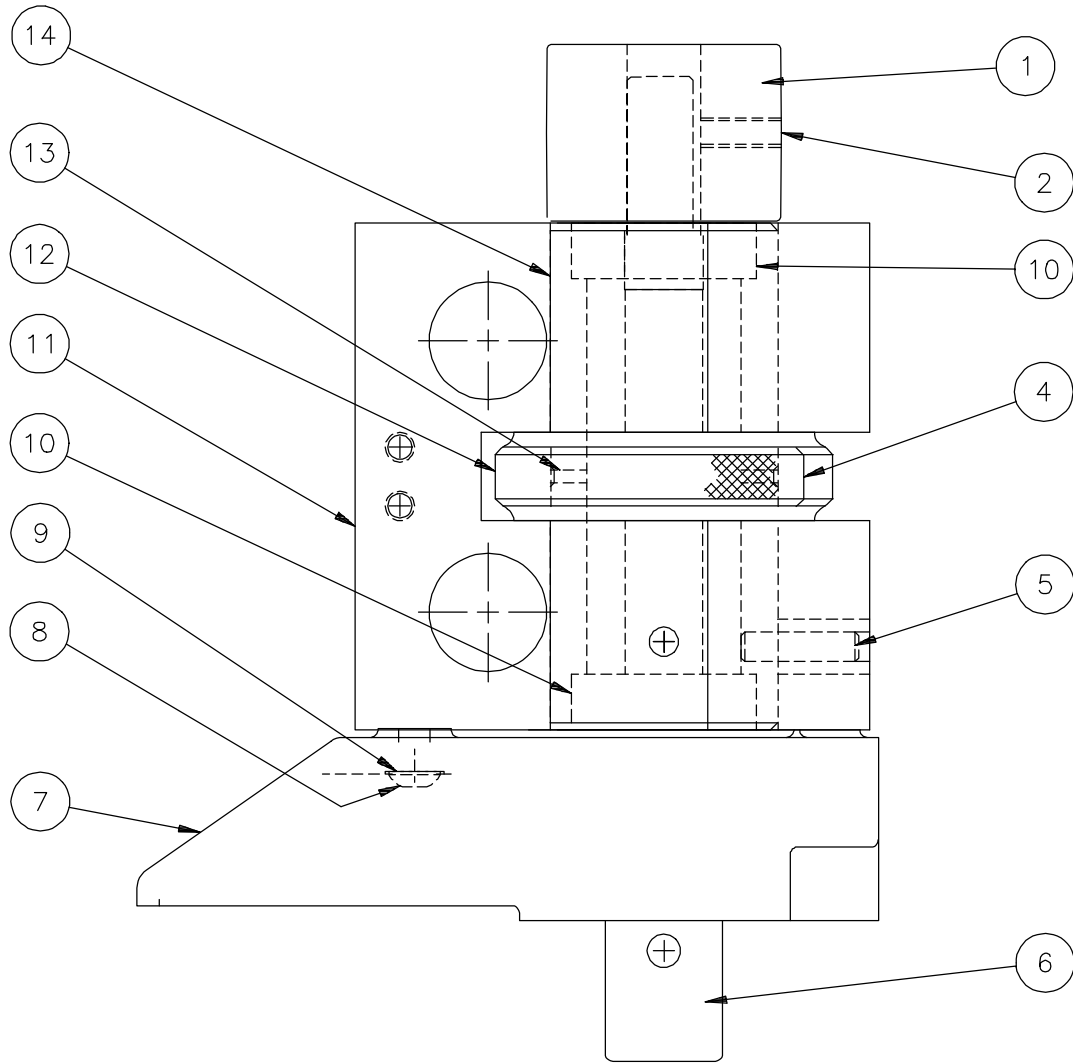

NO.	PART NO.	DESCRIPTION OF ACCESSORIES	QTY
1	4693-1	CROWNED PULLEY	1
2	H-6951-406	1/4 X 3/8 SOCKET SET SCREW(NYLOK)	1
3			
4	5854	COLLAR - BEARING HOUSING	1
5	H-5246-408	1/4 - 1 DOWEL PIN	1
6	K-16-4	SPINDLE	1
7	5873-2	CHIP CHUTE LH	1
8	H-6910-406	1/4 X 3/4 BUT HD CAP SCREW	2
9	H-7327-8	1/4 MED LOCK WASHER	2
10	S-706	6693 BALL BEARING	2
11	5863-1-5	SPINDLE BLOCK LH	1
12	5855-1	ADJUSTMENT NUT	1
13	H-5246-204	1/8 X 1/2 DOWEL PIN	2
14	5853	SLEEVE - BEARING HOUSING	1

# OPTIONAL DRILL SHIELD KIT 48004

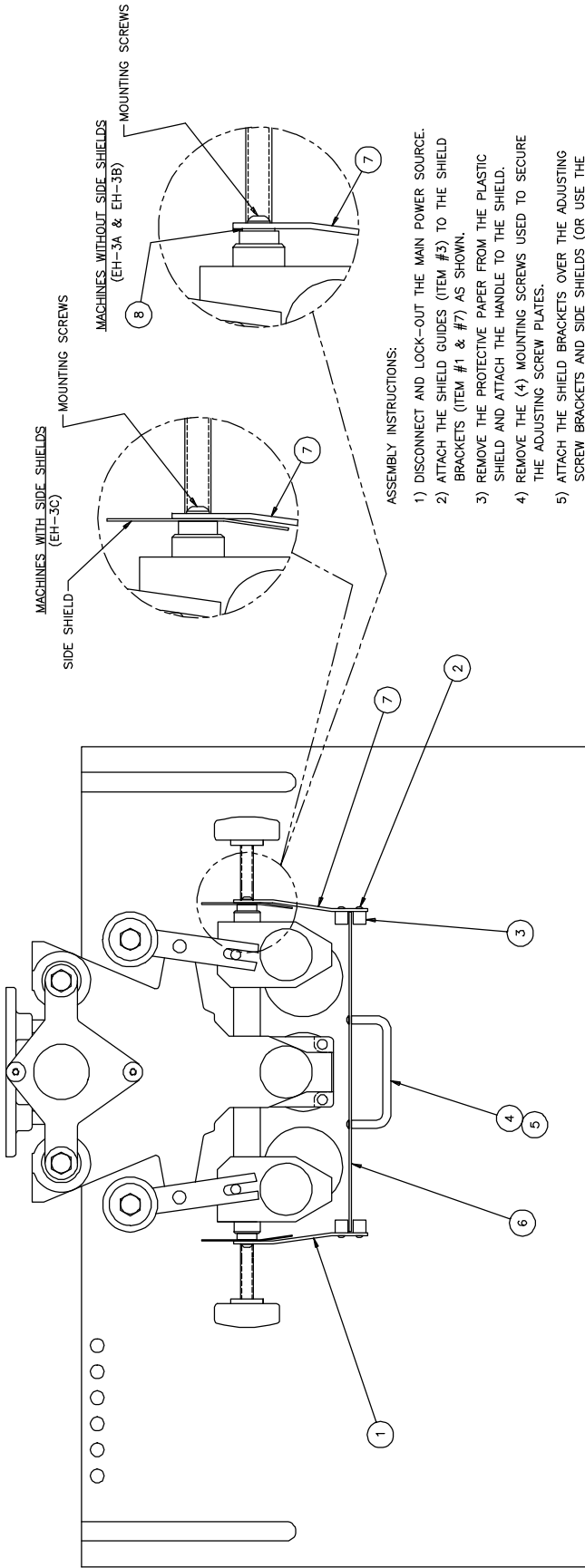

**ASSEMBLY INSTRUCTIONS:**

- 1) DISCONNECT AND LOCK-OUT THE MAIN POWER SOURCE.
- 2) ATTACH THE SHIELD GUIDES (ITEM #5) TO THE SHIELD BRACKETS (ITEM #1 & #7) AS SHOWN.
- 3) REMOVE THE PROTECTIVE PAPER FROM THE PLASTIC SHIELD AND ATTACH THE HANDLE TO THE SHIELD.
- 4) REMOVE THE (4) MOUNTING SCREWS USED TO SECURE THE ADJUSTING SCREW PLATES.
- 5) ATTACH THE SHIELD BRACKETS OVER THE ADJUSTING SCREW BRACKETS AND SIDE SHIELDS (OR USE THE WASHERS PROVIDED IF YOUR MACHINE DOES NOT HAVE SIDE SHIELDS), REUSING THE SAME HARDWARE. (DO NOT TIGHTEN THE HARDWARE)
- 6) INSERT THE SHIELD BETWEEN THE PLASTIC GUIDES, MAKING SURE THE SHIELD IS SQUARE TO THE TABLE AND SLIDES UP FREELY AT LEAST 6".
- 7) TIGHTEN THE ADJUSTING SCREW PLATE MOUNTING HARDWARE.

**VIEWS SHOWN WITH HOOD REMOVED**

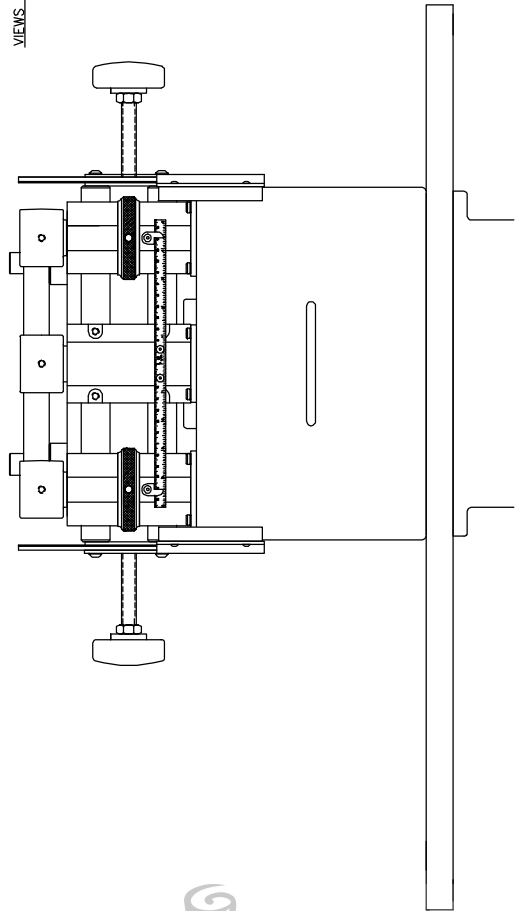

NO.	PART NO.	DESCRIPTION OF ACCESSORIES	QTY
1	48001-1	BRACKET - SHIELD, L.H.	1
2	S-1088-3	#6 X 3/8 PN HD S.M. SCREW	8
3	48002-1	GUIDE - SHIELD	4
4	13940	HANDLE	1
5	H-6910-83202	#8-32 X 1/4 BUTTON HD CAP SCREW	2
6	48003-1	SHIELD	1
7	48001-2	BRACKET - SHIELD, R.H.	1
8	H-7321-4	WASHER - 1/4 PLAIN	4
9			
10			

---

---

# NOTES





