

# Laminex AV VSR Series Laminator

## Instruction Manual



Provided By

**MyBinding.com**  
*When Image Matters.*

# Laminex

## AV Laminators – VSR Series

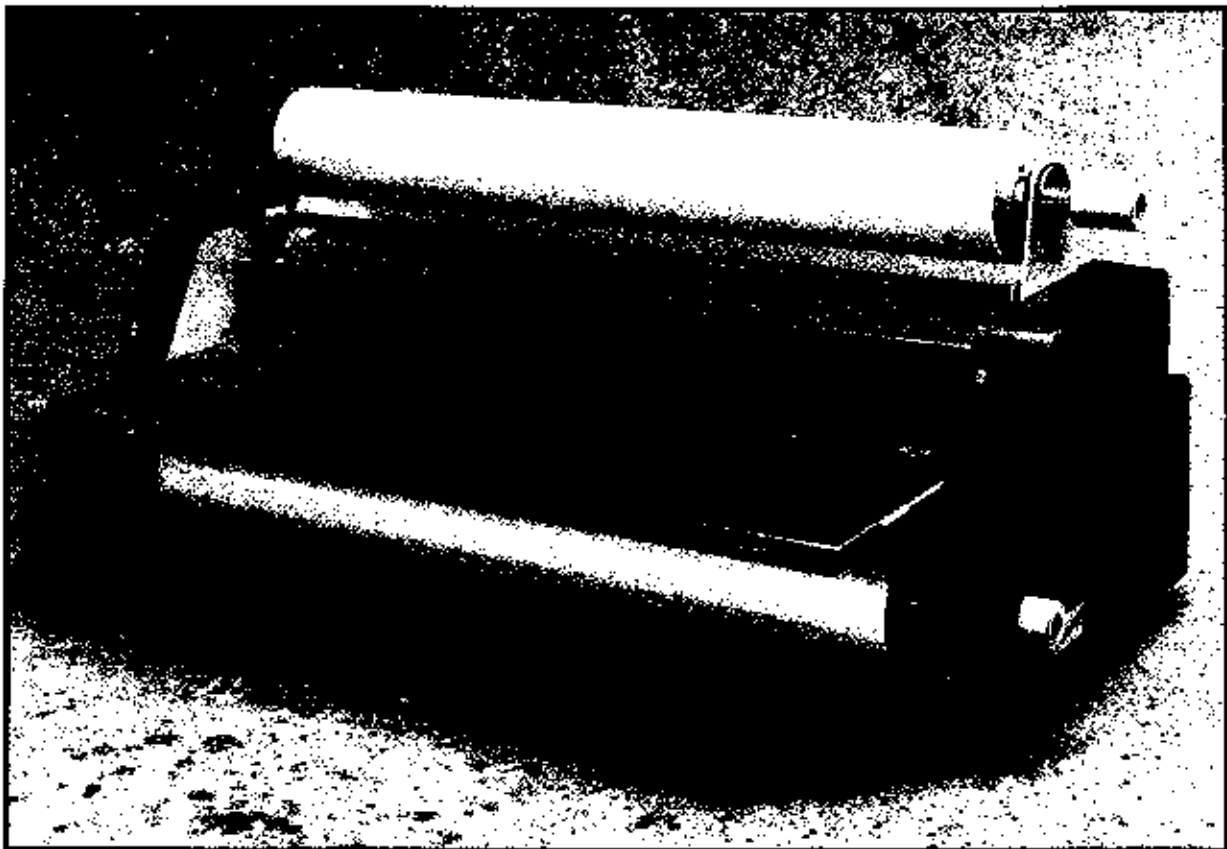

**Easy-to-use  
Operator's  
Manual**

**444VSR (115V & 230V)**

**666VSR (115V & 230V)**

**979VSR (115V & 230V)**

- Read all the safety and operating instructions before connecting or using this unit.
- Retain this notice and the owner's manual for future reference.
- Adhere to all warnings and operating instructions.
- All operating and use instructions should be followed.
- Do not use this unit near water (e.g. near a bathtub, etc.).
- This unit should be installed so that its location or position does not interfere with its proper ventilation. For example, it should not be situated on a bed, sofa, rug or similar surface that may block the ventilation openings; or placed in a built-in installation, such as bookcase or cabinet, that may impede the flow of air through its ventilation openings.
- This unit should be situated away from heat sources such as radiators, heat registers, stoves, etc.
- This unit should only be connected to a power supply outlet of the voltage, amperage and frequency marked on its panel.
- The power supply cord should be routed so that it is not likely to be walked upon or pinched, especially near the plug, convenience receptacles, or where the cord exits from the unit.
- Clean unit only as recommended in its instruction manual.
- The power supply cord should be unplugged from the wall outlet when it is to be unused for a long period of time.
- Care should be taken so that objects do not fall, and liquids are not spilled, into the enclosure through any openings.

# EQUIPMENT WARRANTY

We warrant to the original purchaser the equipment manufactured by us to be free from defects in material and workmanship under normal use and service. Our obligation under this warranty shall be limited to the repair or exchange of any part or parts which may thus prove defective under normal use and service within one year from the date of shipment and which our examination shall disclose to our satisfaction to be thus defective. When necessary, purchaser shall properly pack and return unit to nearest Laminex Service Center, freight and insurance Prepaid. THIS WARRANTY IS EXPRESSLY IN LIEU OF ALL OTHER WARRANTIES EXPRESSED OR IMPLIED INCLUDING THE WARRANTIES OF MERCHANTABILITY AND FITNESS FOR USE AND OF ALL OTHER OBLIGATIONS OR LIABILITIES ON OUR PART, AND WE NEITHER ASSUME NOR AUTHORIZE ANY OTHER PERSON TO ASSUME FOR US, ANY OTHER LIABILITY IN CONNECTION WITH THE SALE OF THIS MACHINE OR ANY PART THEREOF WHICH HAS BEEN SUBJECT TO ACCIDENT, NEGLIGENCE, ALTERATION, ABUSE OR MISUSE. WE MAKE NO WARRANTY WHATSOEVER IN RESPECT TO ACCESSORIES OR PARTS NOT SUPPLIED BY US. THE TERM "ORIGINAL PURCHASER," AS USED IN THIS WARRANTY, SHALL BE DEEMED TO MEAN THE PERSON OR COMPANY WHO FIRST PUTS THE LAMINEX EQUIPMENT INTO SERVICE. THIS WARRANTY SHALL APPLY ONLY WITHIN THE BOUNDARIES OF THE CONTINENTAL UNITED STATES.

## SERVICE CENTERS

Laminex, Inc.  
8350 Arrowridge Blvd.  
Charlotte, NC 28273



## Important Information

**Save Your Carton!** Laminex ships laminators in special cartons which protect them from damage. Please store your cartons in case your laminator should ever require servicing.

**Don't lift your laminator out of the box by the upper mandrel!** This could cause damage. Grasp laminator by its housings to remove.

This manual is provided as an **Operator's Manual** and covers most situations you will encounter while using your laminator. It is not a Technical Service manual. For technical assistance beyond what this manual provides, contact Laminex, Inc.

### Laminex, Inc.

8350 Arrowridge Blvd., Charlotte, NC 28273  
(704) 679-4170, (800) 438 8850

© 1990 Laminex, Inc.

*Laminex reserves the right to make changes at any time.*

*No part of this manual may be reproduced without the written permission of Laminex, Inc.*

*♻️ This manual was printed using 100% recycled paper.*



# Laminex AV Laminator Operator's Manual VSR Series

## Section Index

General Diagrams.....	4
I. Unpacking and Assembly .....	5
II. General Information About Laminating Film .....	5
III. Operating	
a. Loading Film .....	5
b. Threading Film.....	6
c. Heat Adjustment.....	6
d. Supply Roll Tension Adjustment .....	7
IV. Maintaining	
a. Care and Cleaning .....	7
b. Specific Troubleshooting Guide .....	8
c. General Troubleshooting Chart .....	9
Exploded Diagram / Parts List.....	10/11
Wiring Diagram .....	12
General Specifications .....	12



Figure 1: (with feed tray and safety plate removed)

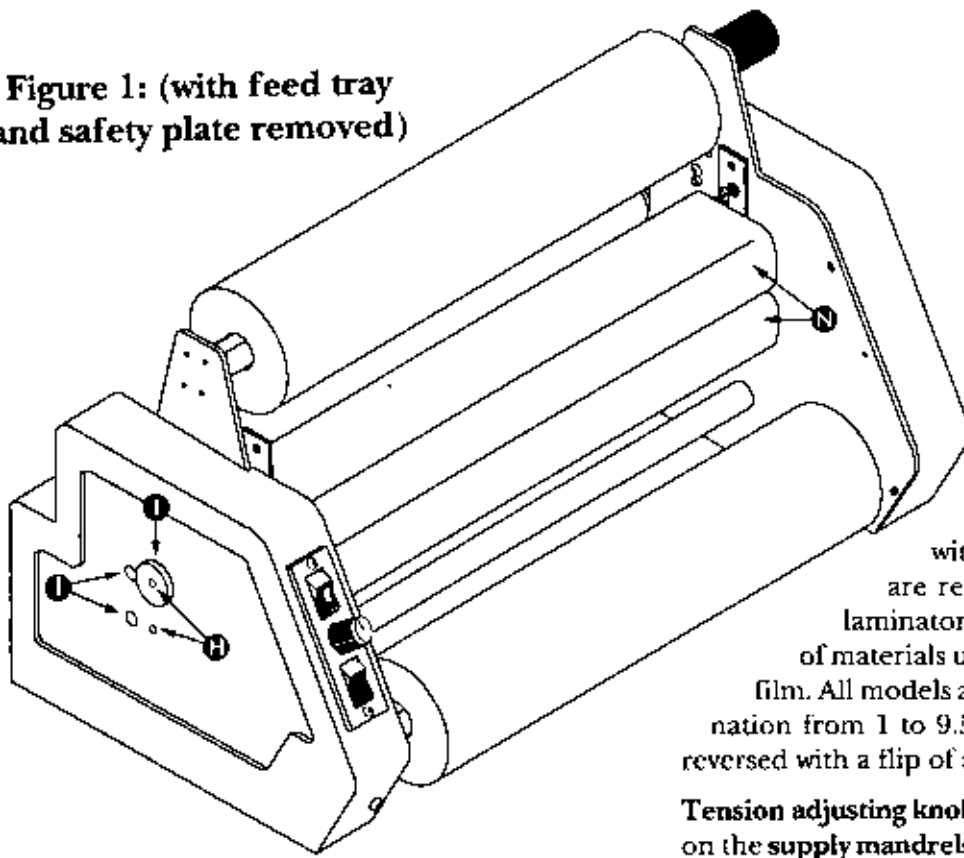

**Laminex VSR Laminators**, with **Variable Speed and Reverse** are reliable, easy-to-use professional laminators designed to laminate a variety of materials using 12", 18" or 25" laminating film. All models are capable of continuous lamination from 1 to 9.5 feet per minute, and can be reversed with a flip of a switch.

**Tension adjusting knobs (A)** are conveniently located on the **supply mandrels (B)** on the right side panel for easy access. A **control panel (C)** is located on the **left housing (D)**, and has a **heater switch with an indicator light (E)**, a **speed control knob (F)**, and a three-position (Forward-Off-Reverse) **motor drive switch (G)**. **Thermometer access ports (H)** on the **left housing (D)** allow for easy temperature readings using the **thermometer (I)** provided. **Heatshoe temperature adjusting ports (J)** make it easy to change the temperature for laminating a variety of films and materials. The **stainless steel feed tray (K)** and **paper guide (L)** provide a smooth and durable paper path into the machine, and the **safety plate (M)** protects hands from the hot surfaces inside. **Teflon coated heat shoes (N)** minimize friction.

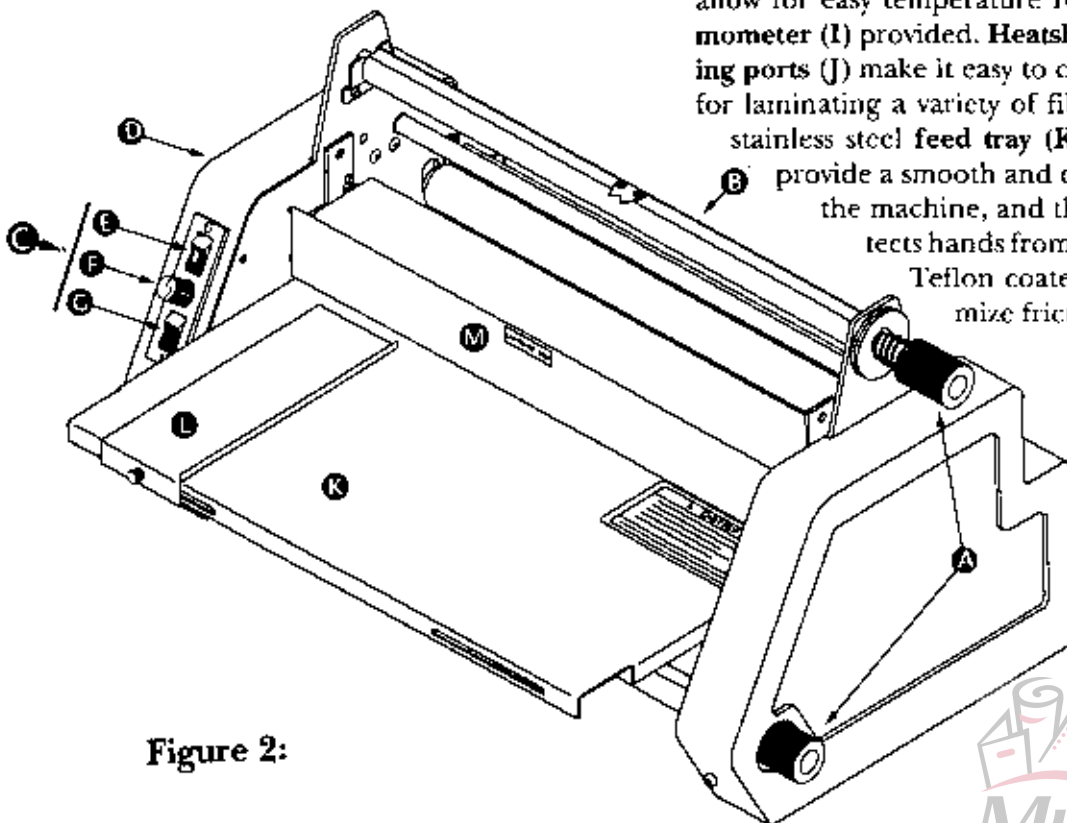

Figure 2:

## I. Unpacking and Assembly

Remove the laminator from its box by grasping the housings and pulling up. Do not use rollers or shafts as handles- this could cause damage. Choose a location for the laminator that is clean, well-lit and draft free. Make sure it is not in the path of any fans, room air conditioners, etc.

The laminator comes fully assembled. All you have to do is load the film onto the supply mandrels and thread the film through the machine.

## II. Information About Laminating Film

Laminating film is made up of two layers: a glossy layer which gives the lamination its strength, clarity and rigidity, and a dull or matte side which is heat activated and serves as the "glue" to bond the film to the product being laminated. Once heated, small amounts of the "glue" side can stick to the heat shoes and rollers and must be periodically cleaned from the laminator.

Laminating film is available in a variety of different lengths, widths and thicknesses. The AV Laminators are designed to use 1.5 mil (#150)

and 3 mil (#300) thick films.

## III. Operating

**Loading Film: 1" Mandrel** (For the I.X Mandrel Kit please see Figures 8 & 9 on page 7.)

Unpack the upper and lower supply mandrels. The upper and lower mandrels are different. The word "TOP" or "LOW" is stamped on the shaft of each mandrel. The ends of each mandrel are also different. The "hanger" end fits in the bracket on the left side of the laminator. The "slot end" fits into the tensioner on the right side (see figure 3).

Slide the film roll onto the mandrel as shown in figure 3, leaving equal lengths of mandrel sticking out of each end. The film roll will slide over the gripper, which will keep the roll from turning on the shaft.

Load the mandrel on the laminator by inserting the slot end of the mandrel into the tensioner on the right side and then lowering the hanger end into the bracket on the left side.

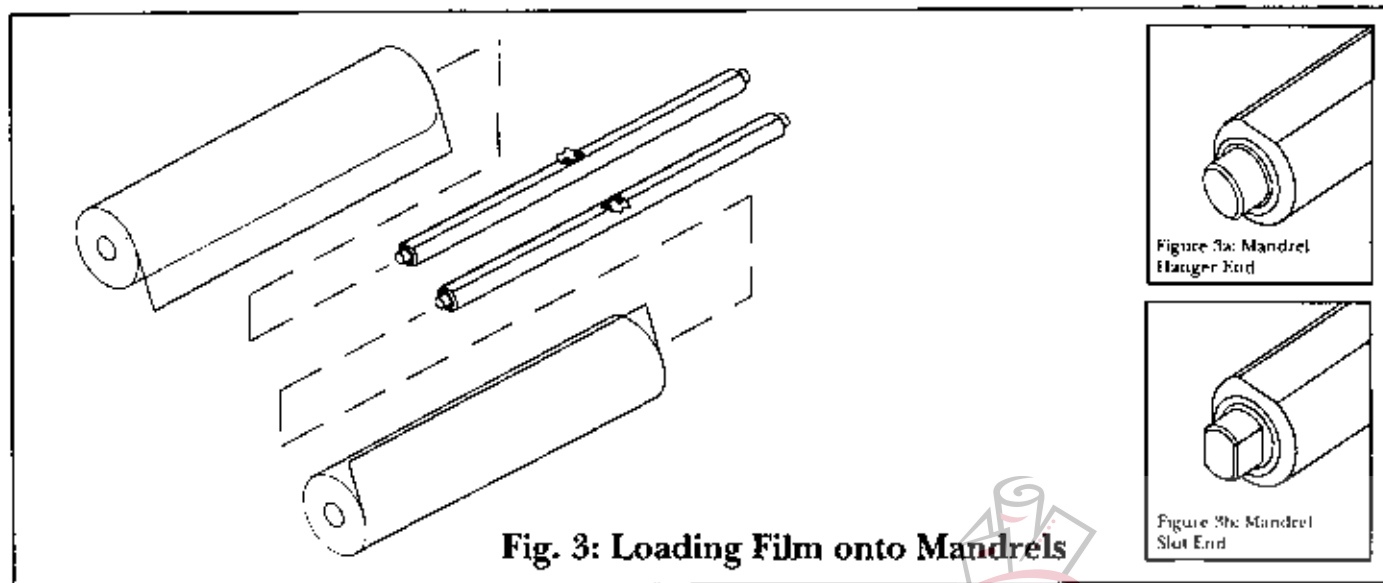

Fig. 3: Loading Film onto Mandrels

## Threading the Film

Make sure the machine is plugged in, but that all switches are "OFF". Thread the film as shown in Figure 4.

Remove the feed tray and the safety plate. Pull the film around the idler rollers as shown. **Do not mistake the reinforcing bar for the idler roller** (see figure 4). Make sure the glossy and dull sides of the film are as indicated in the diagram. Position the feed board provided, as shown in figure 5. If you don't have a feed board, a stiff sheet of paper can be used.

Turn the speed control knob on the control panel all the way counterclockwise (so that the motor turns as slowly as possible), then flip the drive switch to "ON". Slowly turn the speed control knob clockwise until the rollers are barely turning, then thread the feed board and film in between the heat shoes. This will pull the film through the laminating and pull rollers until it comes out the back of the laminator.

Slide the top and bottom film rolls from side to side on the mandrels so that the film is perfectly aligned top and bottom (Note: overlap will cause the film to deposit residue on the heat shoes and rollers, so this procedure is critical). Replace feed tray and safety plate.

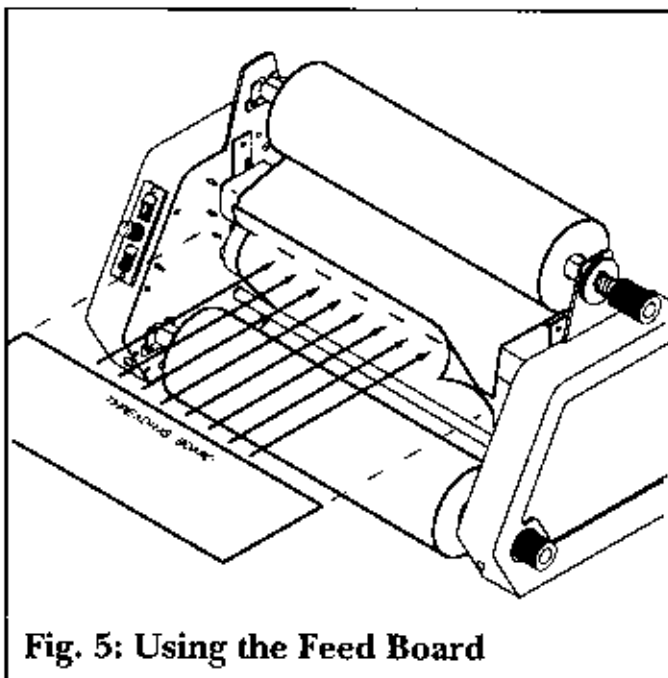

Fig. 5: Using the Feed Board

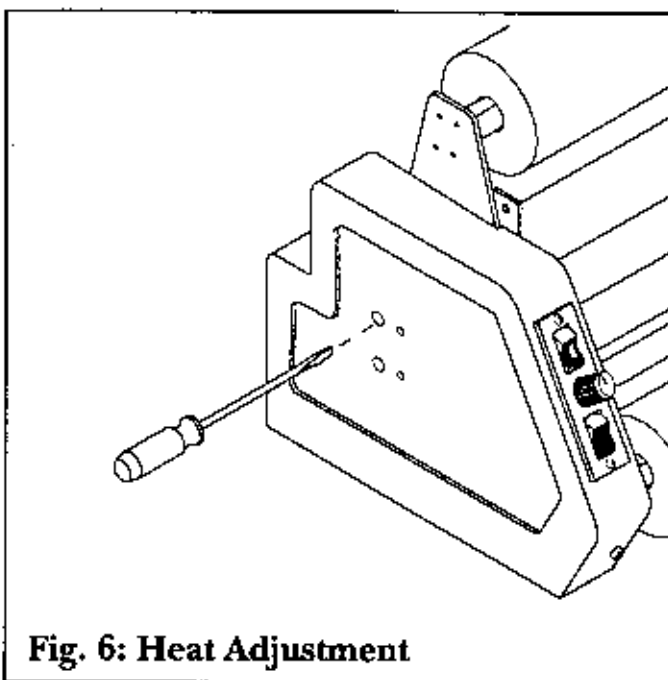

Fig. 6: Heat Adjustment

## Heat Adjustment

Turn the heat switch to "ON" and allow about 15 minutes for the shoes to reach laminating temperature. Check that both heatshoes are hot enough (between 275° and 300°), and at the same temperature, by moving the thermometer from one heat shoe to the other.

The heatshoe temperatures are controlled by thermostats that can be accessed through holes in the left housing of the machine. By

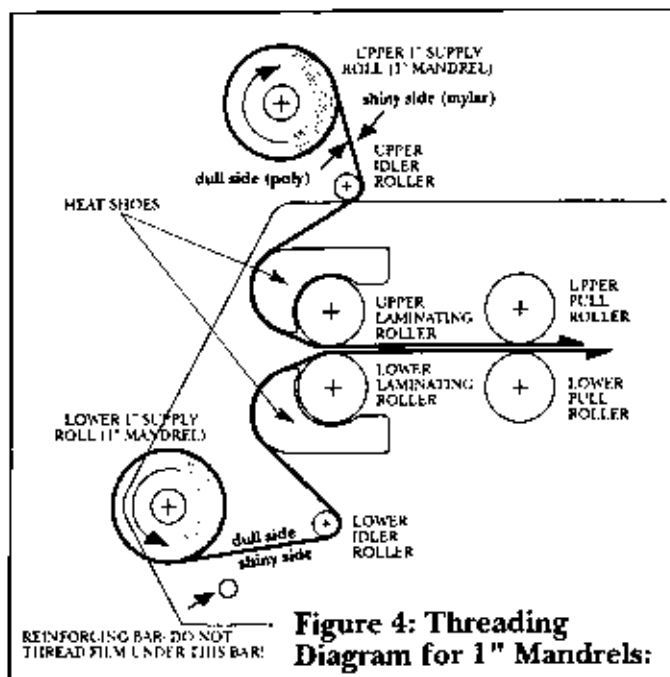
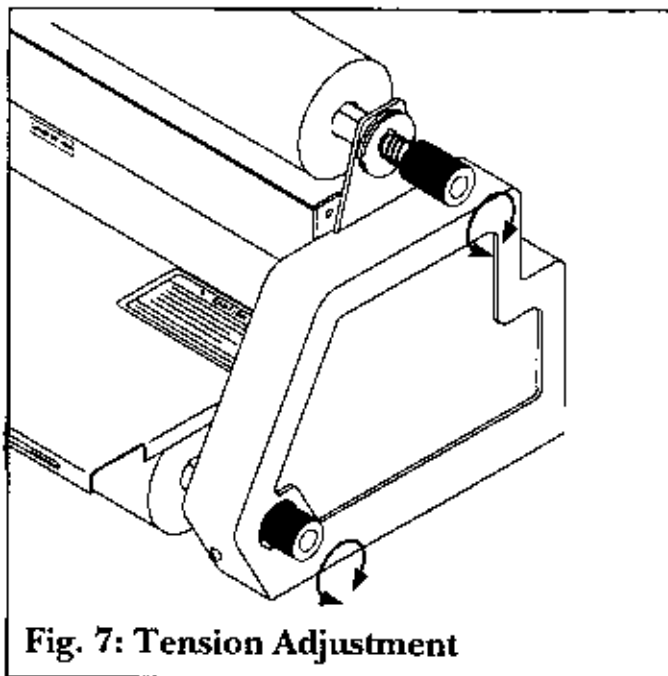

Figure 4: Threading Diagram for 1" Mandrels:



**Fig. 7: Tension Adjustment**

turning a screw with a small flat-blade screwdriver as shown in figure 6, the temperature can be adjusted. To make a temperature adjustment, follow the following procedure:

**Turn the machine off!** Use the screwdriver to

pry off the metal caps covering the access ports. Insert the screwdriver into the port, and turn the screw **clockwise** to lower the temperature or **counterclockwise** to raise the temperature. Each quarter turn changes the temperature 25°.

After any change, use the thermometer to check the temperature of both shoes. **Top and bottom shoes should be at the same temperature**, and between 275° and 300°.

### Supply Roll Tension Adjustment

Top and bottom supply rolls should have about the same tension. By turning the top roll with one hand, and the bottom roll with the other hand, it can be determined if one of the rolls is tighter than the other.

To increase tension, turn the adjusting knob clockwise. To decrease tension, turn the knob counterclockwise. If the tension is not equal top and bottom, the laminated product will curl. If it curls **up** as it comes out of the machine, the top roll is probably tighter than the bottom. If it curls **down**, the bottom roll is probably tighter.

## The LX Mandrel Kit:

*(Do not install this kit unless you will be using Film with 2 5/16" cores)*

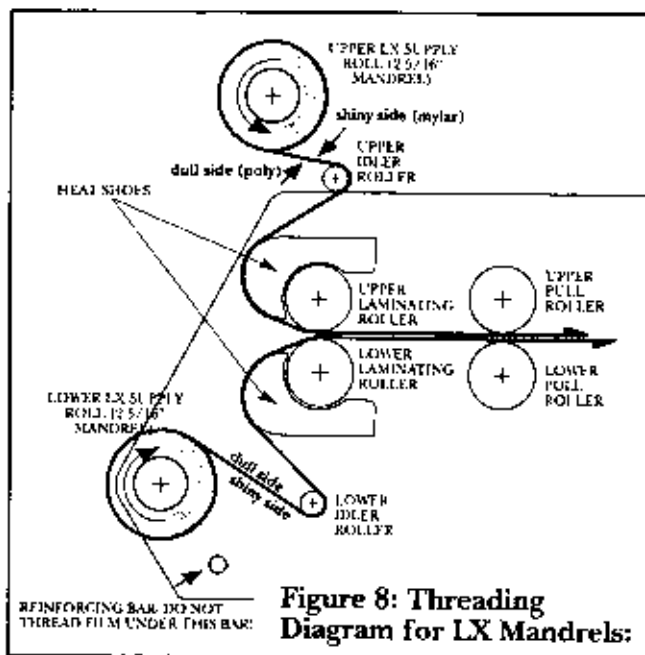

**Figure 8: Threading Diagram for LX Mandrels:**

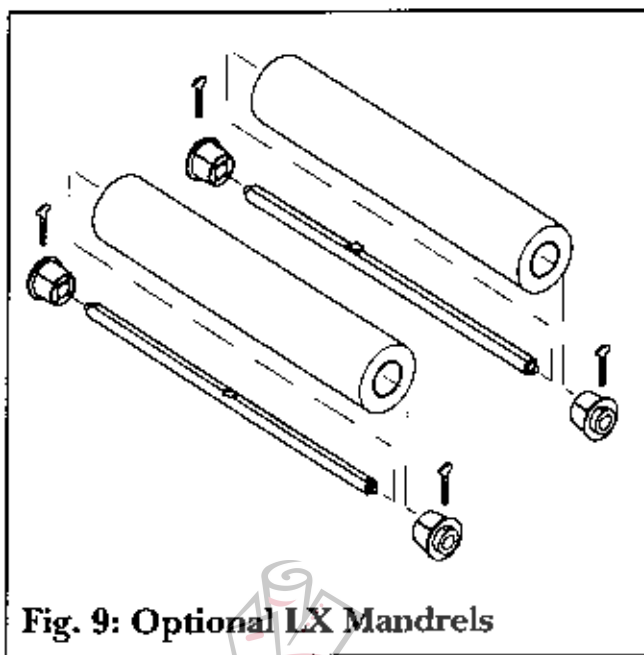

**Fig. 9: Optional LX Mandrels**

## IV. Maintaining the AV Laminator

### Care and Cleaning

In the normal course of operating the AV Laminator, dirt and adhesive will accumulate on the heat shoes and rubber rollers. Laminating produces static electricity which attracts airborne dust and dirt. Regular inspection and cleaning will assure that this does not become a problem. Cleaning kits are available from your local dealer.

**Never** use hard, sharp, or abrasive items to clean the heat shoes. The shoes are coated with a non-stick surface that could be easily damaged. Likewise, do not use sharp metallic objects or steel wool to clean the rubber rollers. Any scratches, indentations, or marks left on the rollers will appear on the laminated product.

To clean the shoes and rollers, use Laminex Poly-Off<sub>3</sub> and a clean, lint-free cloth. If a cleaning kit is not readily available, rubbing (Isopropyl) alcohol will do an adequate job.

### Specific Troubleshooting Guide

#### Removing a "Wrap-Around"

If the "wrap-around" is not severe, simply use the reverse feature of the VSR and back the film out.

**Make sure to remove the Feed Table before reversing the machine!**

For extreme "wrap-arounds" (i.e. when plastic and/or product have wrapped around the rubber rollers several times) follow this procedure:

**Shut the machine off!** Laminex AV Laminators have set screws at both ends of each laminating and pull roller. Loosen all four set screws on both ends of the laminating and pull rollers. Cut the plastic, grab the loose end and pull. The rollers will rotate freely on the roll shafts and the "wrap-around" will easily unwrap. Tighten all the set screws and rethread the film.

#### Drive Sprocket Set Screws

The sprockets and chain drive are located behind the right housing of the machine. Remove

the housing and locate the set screws at the base of each sprocket. These set screws should be tightened on the flat surface of the shaft.

#### Adjusting the Roller Pressure

It is rare that the roller pressure ever needs adjusting, but if the need arises, the following procedure should be followed:

Remove left and right housings from the laminator. Locate the pressure adjustment screws (as shown in figure 10). Adjusting these screws up or down increases or decreases roller pressure. Whenever an adjustment is made to one side, it must also be done to the other side so that both sides apply equal pressure. The only time this is not true is when you are correcting for unequal pressure.

#### Removing the Top Heatshoe

Occasionally it is necessary to remove the top heatshoe from the laminator. The following procedure should be followed:

**Unplug the Laminator!** Remove the left housing. There are four wires coming out of the heatshoe. Two are crimped together with a white cap and two connect to the terminal strip. The

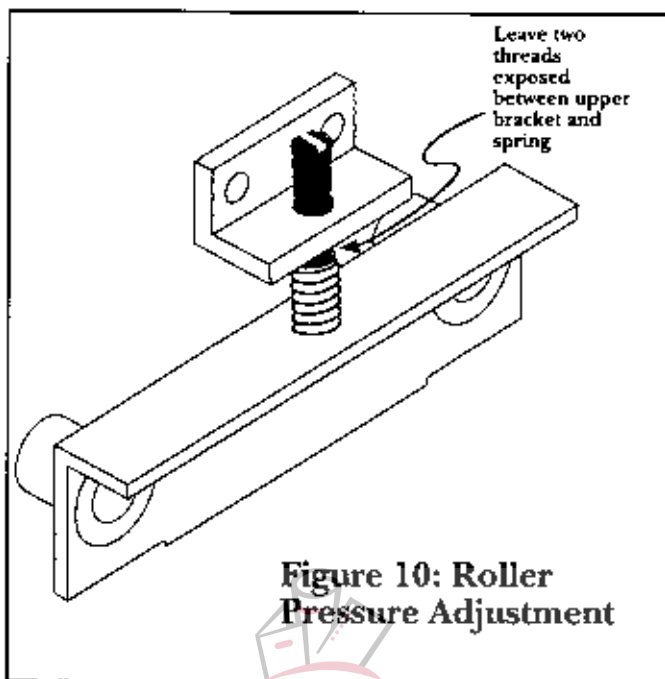

Figure 10: Roller Pressure Adjustment



short terminal strip wire connects to #1 on the terminal strip and the long one to #4. Disconnect these two wires at the terminal strip.

The heat shoe simply rests in the two hangers on either side. To remove it, lift up and out, guiding the wires out of the frame as you remove the heatshoe.

**Figure 12: General Troubleshooting Guide\***

	INCREASE HEAT	DECREASE HEAT	WORN, DIRTY OR DAMAGED ROLLERS	INCREASE TENSION ON SUPPLY ROLLS	DIRTY HEAT SHOES	MOIST OR COATED PRODUCT	DECREASE TENSION ON SUPPLY ROLLS	REDUCE SPEED	CHECK SET SCREWS	CHECK THREADING DIAGRAM	INCREASE ROLLER PRESSURE
Wrinkles on film (side to side)		●	●	●							●
Wrinkles on film (lengthways)	●				●		●				
Plastic not bonding	●						●				●
Bubbles or Blisters		●	●		●						
Rollers not turning								●			
Impressions on product			●								
Squeaking sounds						●		●		●	
Film narrowing on shoes						●				●	
Film wrinkling on shoes	●			●							
Continuous blemish			●		●						
Cloudy Film	●										
"Orange Peel" finish		●									
Roller slips or jogs								●			
Film sticks to rollers			●							●	
Film sticks to shoes				●						●	
Film won't stay aligned										●	
No seal on edges	●			●			●				●
Poor seal- one side only					●						●

\* When using this chart, try only one solution at a time, then test it before trying another.

# AV - 999 VSR w/ FANS Bill of Materials

201535

1	707905BEG	FEED TABLE, MINIKOTE 27"	63	801988	FUSE HOLDER
2	601345	SCREW #8-32x1/2"	64	801967	FAN, 120SQx38MM. 105CFM. 115VAC
3	707286BEG	LEFT FEED, MINIKOTE	65	801968	FAN-GUARDS BOXER IMC#0550099
4	801977	FOOT, RUBBER 2580	66	601116	6-32x1-7/8" PHIL.LIPS PAN HEAD
5	907559	LEFT SIDE PANEL SA	67	603330	6-32 HEX NUT w/LOCK WASHER
6	604840	WASHER, 1/4" SPLIT LOCK	68	651042	UPPER IDLER ROLL 27" MINIKOTE
7	600750	SCREW, 1/4-20x5/8" BHS	69	600193	1/4x1" SHOULDER SCREW
8	650802	27" PULL ROLL GRAY	70	707229	PRESSURE ADJUST BRACKET
9	600080	10-32x1-1/4" SHC	71	707231	UPPER & LOWER LEFT SUPPLY
10	600350	SET SCREW 10-32x3/8"	72	801995	HEAT SHOE HANGER
11	707412	KNOB	73	801938	POWER CORD
12	802313	THERMOMETER, 5" PLAIN	74	620116	STRAIN RELIEF BUSHING
13	610511	PLUG, 1/2" BLACK	75	707234	BASE CHANNEL
14	707614	LEFT SIDE COVER			
15	707211	SCREW, PRESSURE ADJUSTMENT			
16	802155	SPRING, PRESSURE, MINIKOTE			
17	707224	PRESSURE ADJUSTMENT PLATE, MINIKOTE			
18	654095	BUSHING, UPPER ROLL AV			
19	801923	MOTOR CONTROL, KBIU-11 PMCL			
20	907411U	UPPER SUPPLY ROLL SA ARL-27"			
21	707487	AV SWITCH MOUNTING BRACKET			
22	650801	27" RUBBER ROLL			
23	600715	SCREW, 10x1/2" PAN PHD. (ZINC)			
24	707465	SWITCH PLATE, AV			
25	707496	MOTOR HOUSING 27" MINIKOTE			
26	707901	SHAFT, UPPER ROLL 27" ARL			
27	707902	SHAFT, LOWER ROLL 27" ARL			
28	802102	MOTOR V01925AD83 115V			
29	908011	CHAIN, 21" MINIKOTE			
30	801207	SPROCKET 25B19 1/2"			
31	801206	SPROCKET 25B20 1/2"			
32	801205	SPROCKET 25B23 5/16"			
33	707613	RIGHT SIDE COVER, 27"			
34	707399	TENSION KNOB AV			
35	802160	SPRING, COMPRESSION			
36	707406	FRICTION PLATE, AV			
37	707405	WASHER, LEATHER 1" AV			
38	907558	RIGHT SIDE PANEL SA, MINIKOTE			
39	707415	FRICTION STUD			
40	707661	HEAT SHOE, 27" ARL UPPER			
41	707241	HEAT SHOE MNTG BRKT, MINIKOTE			
42	600710	SCREW #10-32x1" BHS			
43	610030	SPACER, 1/4x13/32"			
44	610040	SPACER, 1/4x3/4"			
45	707663	HEAT SHOE, 27" ARL LOWER			
46	707062	IDLER ROLL DOWEL			
47	604955	WASHER, .265x.500x.015 THK			
48	707907	LOWER IDLER ROLL 27" ARL			
49	907411L	LOWER SUPPLY ROLL SA ARL-27"			
50	707904	REINFORCING BAR ARL 27"			
51	707903BEG	HEAT GUARD, MINIKOTE 27"			
52	654090	BUSHING, LOWER ROLL AV			
53	603340	TINNERMAN NUT #8-32			
54	802019	HEATER 768 WATT, 999, 120V			
55	802334-275F	CALIBRATED THERMOSTAT-275F			
56	802227	3 PT. ROCKER SWITCH			
57	802242	LIGHTED SWITCH, 120V 20 AMP			
58	600345	SET SCREW 10-32X1/4			
59	611020	#6-32x3/8" PHIL PAN HD w/PATCH			
60	601112	#6-32x1/2" RH, NYLON SLOTTED			
61	707624	REAR ROLLER GUARD, 27" MINIKO			
62	802445	FUSE, 1A/250V SLOTTED			



201535

4-30-98 Rev 1

When Image Matters.

19

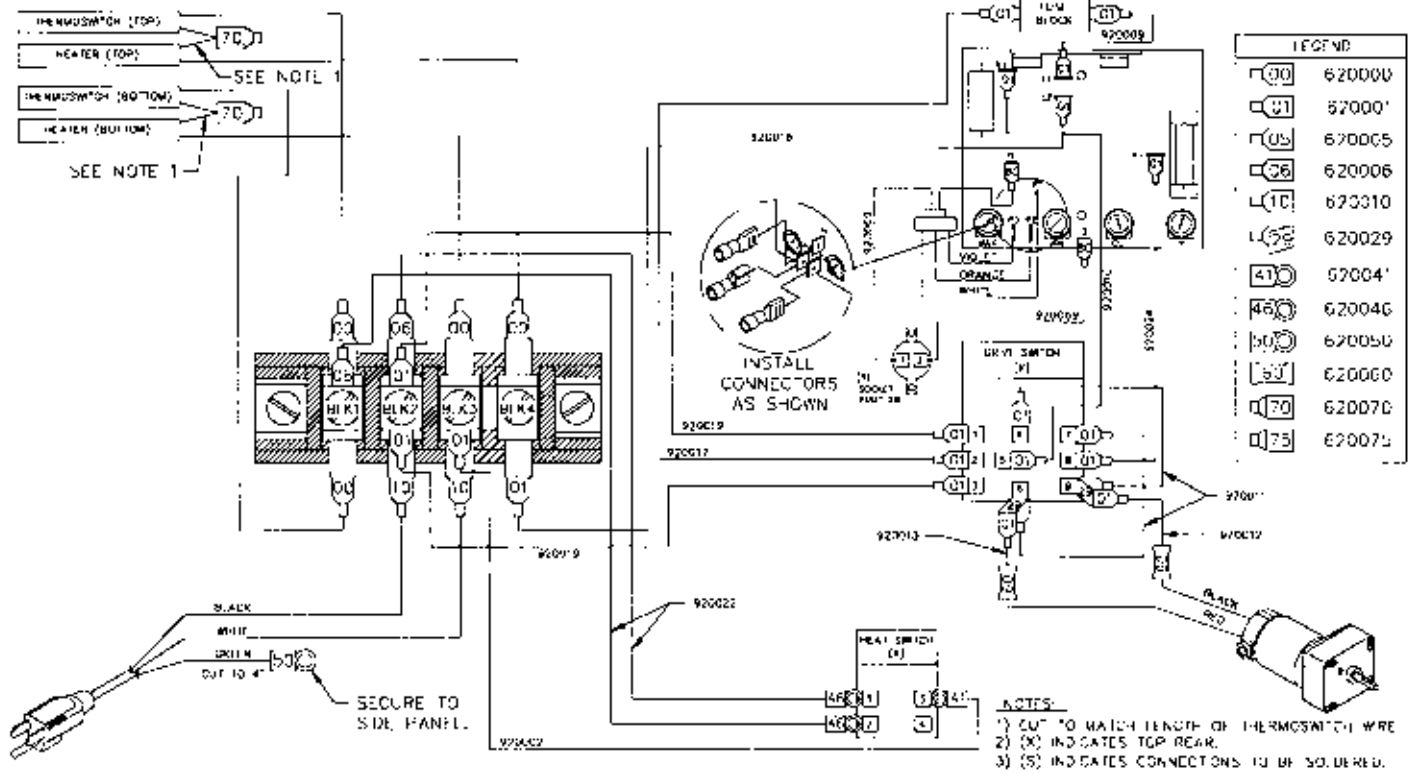

### 999 VSR - WIRING DIAGRAM

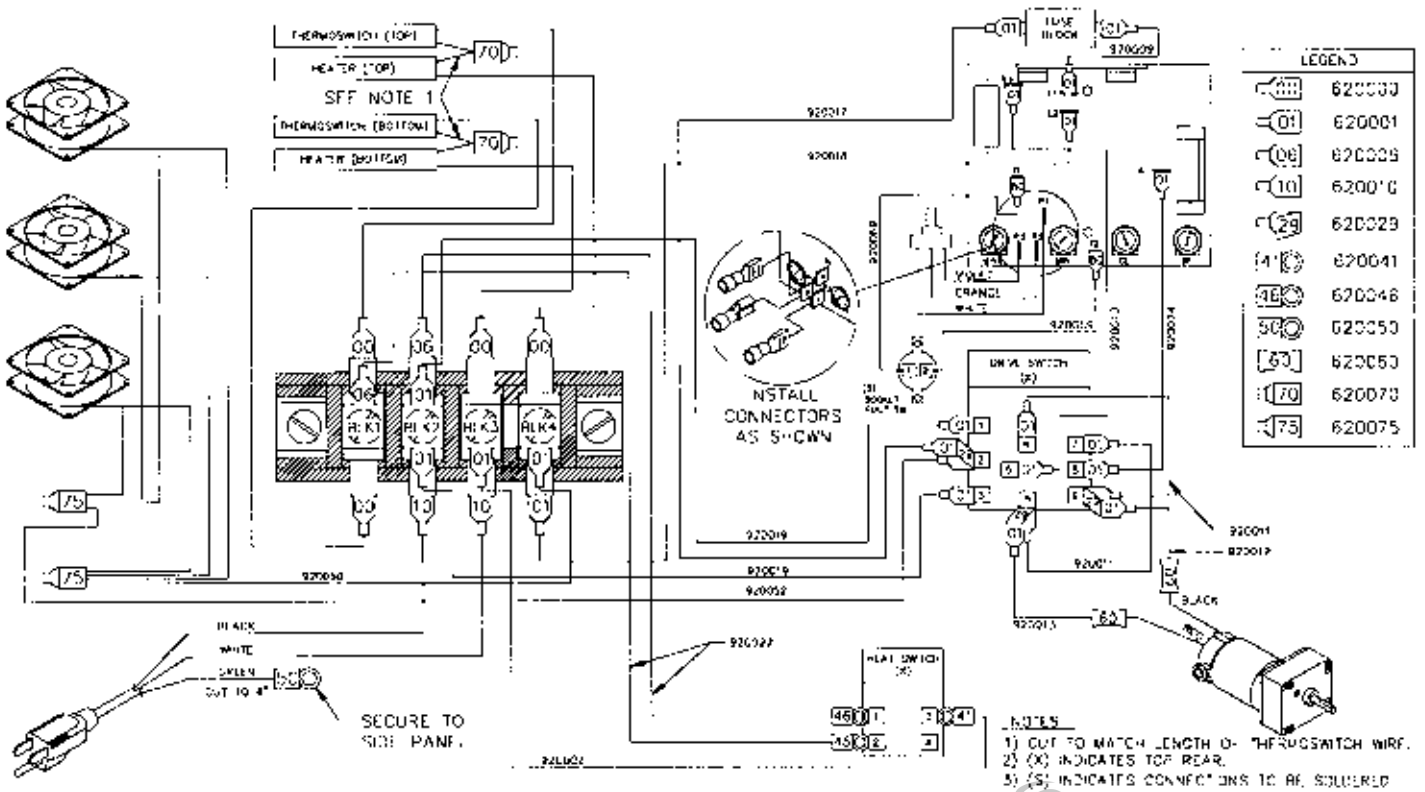

### 999 VSR WITH FANS - WIRING DIAGRAM



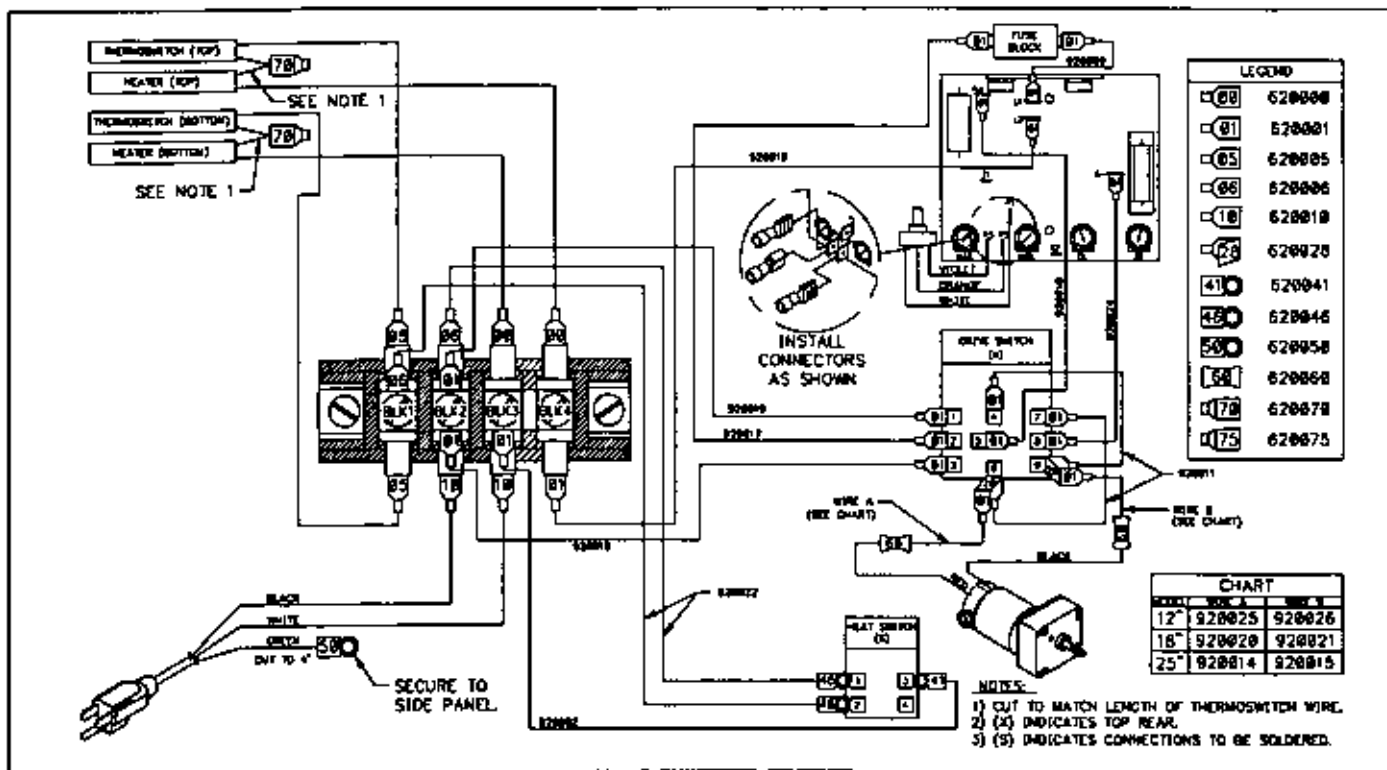

Figure 13: Wiring Diagram

## General Specifications:

**444VSR** (Item #201035)    **666VSR** (Item #201055)    **979VSR** (Item #201075)

Height	15"	15"	15"
Width	18"	24"	32"
Depth (with feed tray)	20"	20"	20"
Net weight	37 lbs.	52 lbs.	63 lbs.
Shipping weight	45 lbs.	62 lbs.	70 lbs.
Width of Lamination	12"	18"	25"
Electrical: (Standard)	115V AC, 60Hz, 1500w	115V AC, 60 Hz, 1700w	115V AC, 60 Hz, 1536w
Electrical: (Optional)	230V AC, 50Hz, 1500w	230V AC, 50 Hz, 1700w	230V AC, 50 Hz, 2300w

**Laminex AV 999VSR (Item # 201530)  
& AV 999 VSR with Fans (Item # 201535)  
27" Roll Laminator**

**General Specifications:**

**999VSR**

Height	13"
Width	34"
Depth (with Feed Tray)	20"
Net Weight	63#
Shipping Weight	70#
Width of Lamination	27"
Electrical	115V AC, 60 Hz, 1536W

**Laminex**

D & K Laminex, Inc.  
8350 Arrowridge Blvd.  
Charlotte, NC 28273  
(800) 438-8850