

Martin Yale 3800 AP/FC Paper Folding Machine

Parts List



Provided By

MyBinding.com®
When Image Matters.

3800 AP/FC Parts List

<u>Ref. No.</u>	<u>Part Number</u>	<u>Qty.</u>	<u>Description</u>
1	M-O095138	1	Urethane Friction Driver
1A	M-S013033	1	Friction Driver Bearing
1B	M-O095113	1	Plain Axle
2	M-O095107	2	Auxiliary Feed Extension Spring
3	M-O003548	1	Auxiliary Feed Roller Rubber
3A	M-O095108	1	Small Feed Arbor
3B	M-O095109	1	Spring Loaded Axle
4L	W-O380011	1	Paper Guide Left Hand
4R	W-O380012	1	Paper Guide Right Hand
5L	W-O380016	1	Guide Support Left Hand
5R	W-O380015	1	Guide Support Right Hand
6L	W-A380002	1	Main Frame Left Hand
6R	W-O380001	1	Main Frame Right Hand
7	M-S007008	14	10-32 Keps Nut
8	W-O380018	1	Fine Adjustment Knob
9	M-O380019	1	Fine Adjustment Bushing
11	M-O380093	1	Spec. 18T Gear
14	WRA380500	1	Speed Control
14A	M-S032057	1	Speed Control Knob
15	M-S045002	1	Circuit Breaker
16	M-S004029	8	8-32 X 1" Screw
17	W-A380072	1	Side Cover Left Hand
18	W-A380098	1	Aluminum Bezel Trim Right Hand (Auto Perf.)
18A	W-A380099	1	Aluminum Bezel Trim Rightt Hand (Forms Cutter)
21	M-S037001	1	Power Cord
22	M-S032047	1	Hand Wheel w/ Set Screw
22A	M-S002006	1	10-32 X 3/8" Set Screw
25	M-S032044	1	Control Lock Knob
26	M-S022017	1	Timing Pulley 12T X L037
27	M-S022021	1	Timing Pulley 60T X L037
28	M-S025008	1	Timing Belt 144 X L037
29	M-S021048	1	120V DC Motor
30	M-O003036	4	18T Idler Gear
31	M-O003035	5	18T "D" Gear
32	M-O095050	5	Idler Gear Studs
33	W-O380051	1	Motor Base
34	M-O380038	1	Micro Switch Cam Bushing
35	M-S033030	1	Micro Switch
36	M-O380057	1	Square Shaft
37	W-O380056	1	Square Shaft
38	W-O380059	4	Aluminum Stripper Fingers

<u>Ref. No.</u>	<u>Part Number</u>	<u>Qty.</u>	<u>Description</u>
39	M-S003045	8	10-32 Screw
39A	M-S032045	8	Screw Cap
40	M-O380039	1	Height Adjustment Shaft
41	W-A380044	2	Accessory Shaft
42	M-O380067	2	Cutter Hub
43	W-A380024	1	10 Tooth Slot Perf. Wheel (Auto Perf.)
43A	W-A38024A	1	7 Tooth Slit Perf. Wheel (Forms Cutter)
43B	WRA38024B	1	3 Tooth Slit Perf. Wheel (Optional)
44	M-S001011	4	8-32 X ½" Screw
45	M-S030003	4	Rubber Bumper
46	M-S007006	8	8-32 Keps Nut
47	M-S001011	4	8-32 X ½ Phillips Pan Head Screw
49	W-A380065	1	Slitter Assembly (Forms Cutter)
50	M-O380066	2	Scoring Wheel (Auto Perf.)
51	M-O380058	1	Acrylic Cover
52	M-O380032	1	Bearing Mount Plate
53	WRA380047	1	Exit Roller Assembly
54	W-O380045	2	Pinch Roller
55	M-O003104	7	Index Pin
55A	M-O095242	1	Tapered Index Pin
56	M-O380040	1	Height Adjusting Arm Right Side
56A	M-O380091	1	Height Adjusting Arm Left Side
56B	M-S020006	2	Self Aligning Bearing
56C	M-S013007	2	3/8" X ½" X 1" Oilite Bearing
58	WRA380046	1	Entry Roller Assembly
59	W-O380020	1	Tie Rod
60	M-O380017	1	Fine Adjustment Shaft
61	M-S001129	6	6-32 X ¼" Phillips Pan Head Screw
63	M-S001110	4	8-32 X 5/8" Phillips Flat Head Screw
64	W-O380060	1	Front Plate Assembly
65	W-A380003	1	Feed Table Assembly
66	W-A380030	1	Feed Roller Shaft
67	M-O380095	1	Feed Roller Rubber
68	WRA003116	1	Retarder Rubber with Arbor
69	W-A095119	1	Retarder Block Assembly
71	W-O380014	2	Leaf Spring Assembly
71A	M-O380013	2	Leaf Spring Stud
72	M-S032042	2	Leaf Spring Knob
73	W-O380096	2	Bottom Aluminum Trim
74	W-O380073	1	Side Cover Right Hand
75	W-O380097	1	Aluminum Bezel Trim Left Hand
76	W-A380079	1	Receiving Tray
80	WRA380085	2	Acrylic Side Guide Assembly
81	WRA380087	2	Acrylic Back Stop Assembly

<u>Ref. No.</u>	<u>Part Number</u>	<u>Qty.</u>	<u>Description</u>
82	W-O380094	2	Exit Strap
83	M-S032057	1	Depth Adjustment Knob

220V Machines: Same Parts Except:

14	W-A095207	1	Speed Control w/ Knob
21	M-S037286	1	Power Cord
29	M-S021022	1	220V DC Motor

Not Illustrated:

W-O380029	1	Stripper
M-S012012	1	3/32" X 6" T Allen Wrench
M-S013009	4	Oilite Bearing w/ Flats
M-S013010	7	Flanged Oilite Bearing
M-O380043	1	Height Adjusting Stud
M-S013013	1	1/2" ID Oilite Bearing
M-S033024	1	8 Positive Terminal Strip 220V only

3800 Parts Diagram

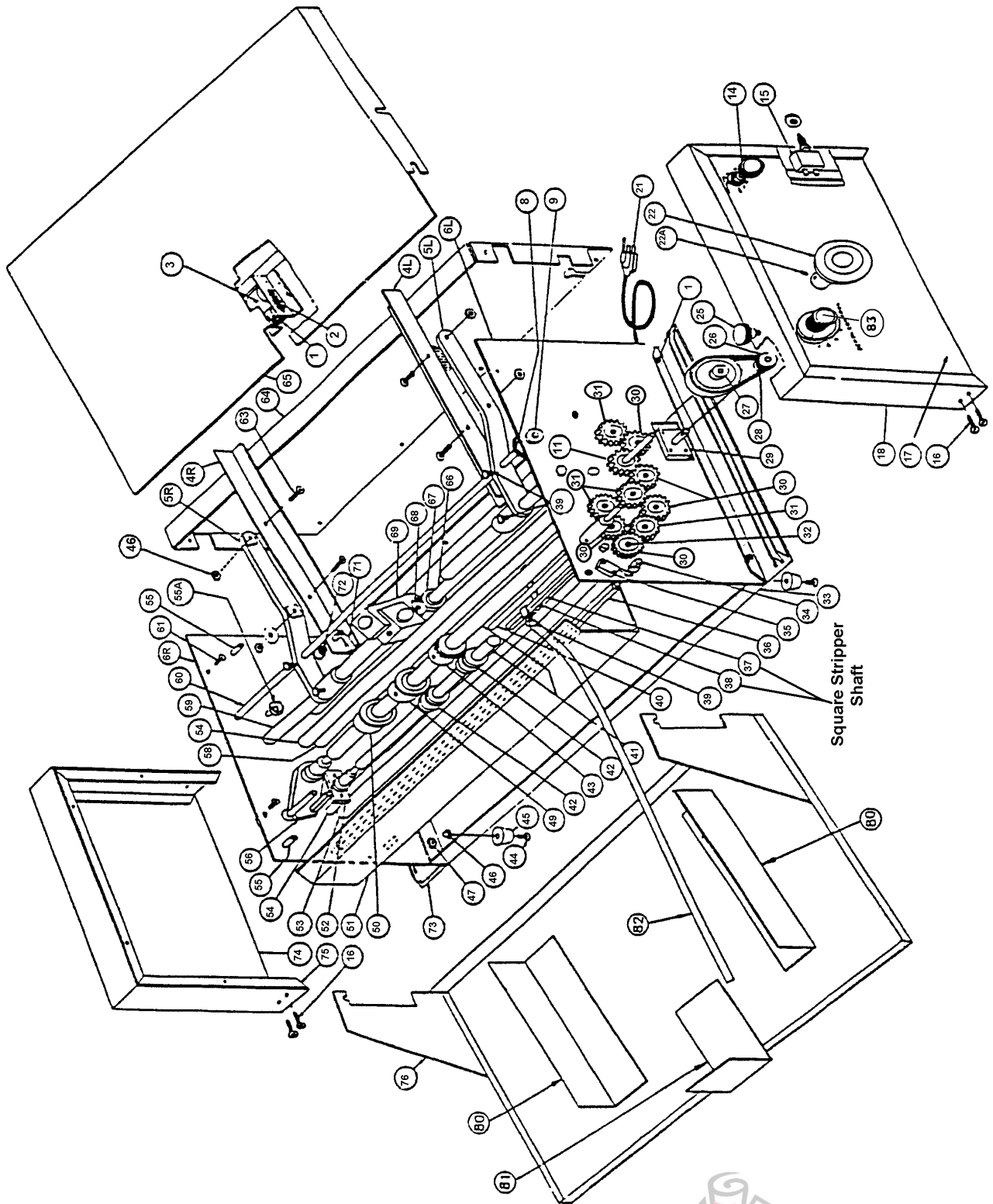

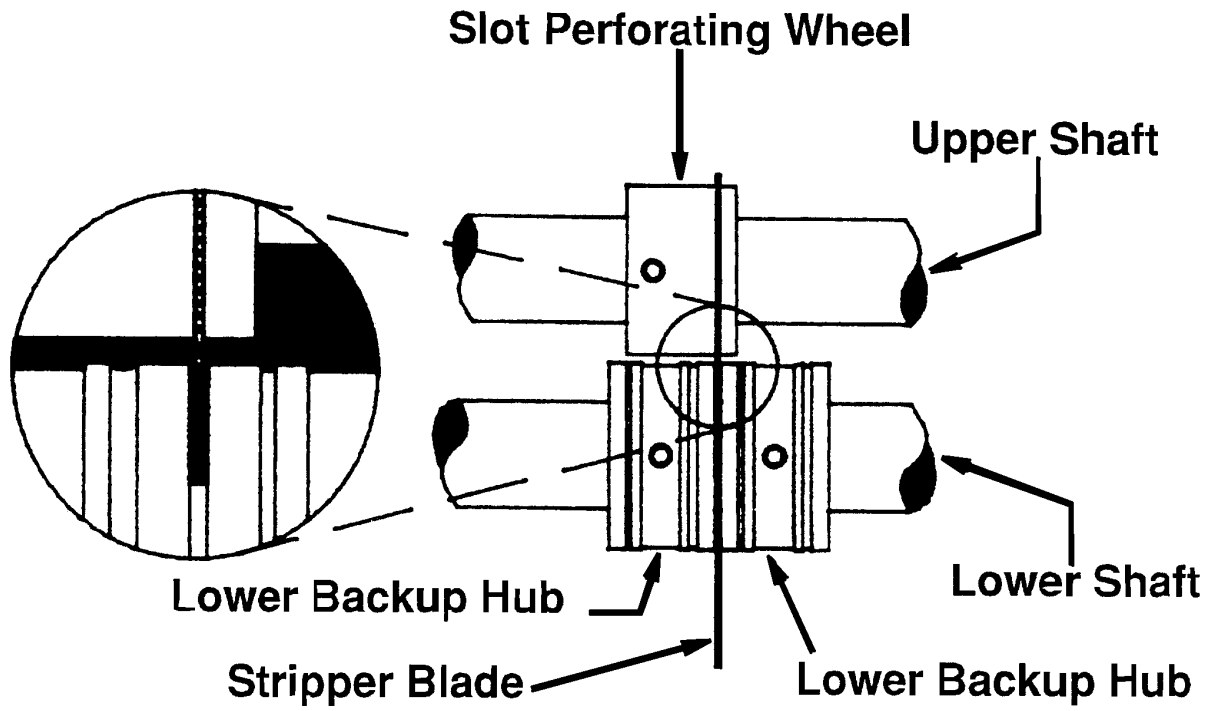

Figure 3

