

Plockmatic BM 2000 Booklet Maker

Service Manual 2



Provided By

MyBinding.com®
When Image Matters.

3. REPLACEMENT AND ADJUSTMENT

3.1 GENERAL CAUTIONS

⚠ WARNING

Turn off the main power switch and unplug the machine before attempting any of the procedures in this section.

Using the ESD Ground Strap

Purpose

The purpose of the ESD (Electrostatic Discharge) ground strap is to preserve the inherent reliability and quality of electronic components handled by the Service Representative. The strap should be used whenever handling the circuit boards or any other ESD sensitive components.

Replacement
Adjustment

Procedure

NOTE: All procedures requiring use of the ESD ground strap will contain a caution referring to this procedure.

- 1 Switch off the main power switch.
2. Make sure the power cord connects the machine to the wall outlet. The power cord and wall outlet must have ground.
3. Connect the claw end of the grounding cord to a chassis ground, such as earth wires screwed to chassis ground, unpainted frame or an unpainted bracket secured to the frame.
4. Connect the snap end of the blue cord to the snap on the adjustable wrist strap.
5. Place the adjustable wrist strap securely on the wrist. Wait for one minute to let the electrostatic be discharged from your body.
6. ESD sensitive components can now be handled without causing any ESD related damage.
7. New replacement PCBs and ESD sensitive components, as well as old defective PCBs should be handled during unpacking and repacking using the ESD ground strap. During the transfer from or to the packaging material, the PCB should be placed on the ESD bag the replacement PCB came in.

⚠ CAUTION

ESD Hazard! ESD (Electrostatic Discharge) can cause software crashes, data and/or communications problems. Failure to use proper ESD procedures will cause damage to electronic components (example: PCBs). ESD problems can be minimized by maintaining all machine ground connections, ensuring the proper handling of circuit boards/ sensors, refer to this procedure 3.1.

- Use ESD protection when working near PCBs. Failure to use ESD protection is likely to result in a PCB failure.

Page intentionally blank

3.2 SPECIAL TOOLS AND LUBRICANTS

3.2.1 SPECIAL TOOLS

In order to facilitate the service of the BM 2000 Booklet Making system there are a few special tools needed.

Where part number is written it can be purchased from your supplier.

Replacement
Adjustment

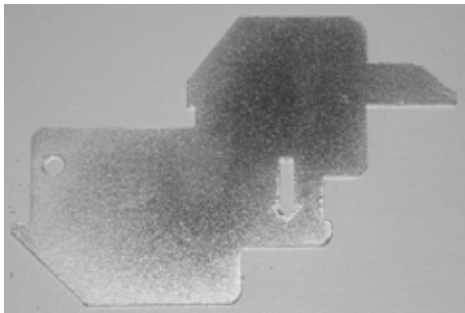

Interlock cheater
(One pcs included
in each module)

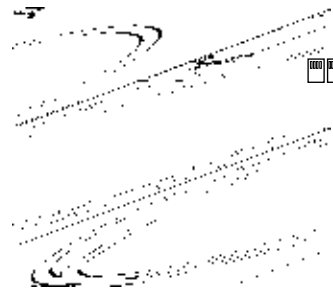

Software loading cable
(Not included in BK5010.
Part No. SR770010)

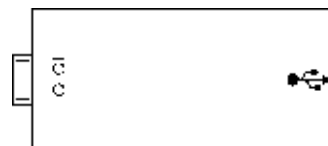

USB converter
(Not included!
Purchase locally)

NOTE: For the BM 2000 Booklet Making system not to be interlocked (interlocked=36V interrupted), the Interlock switch must be activated and the Interlock magnet must be blocked with a metal. Use the Cheater to override the interlock for running the system with open top covers:

1. Hold the Cheater above the interlock so the arrows meet.
2. Put in the left end in the slot so it hooks under the bracket.
3. Push the Cheater down and to the right so it latches in place.

3.2.2 REQUIRED TOOLS

Open wrenches:

5.5, 7, 8, 10 and 13 mm. 19/24 mm comes with the machine.

Allen keys:

1.5, 2, 2.5, 3 and 4 mm.

Torx T-20 (TX20).

Metric Sliding calliper.

3.2.3 SYMBOLS USED IN TEXT

Go to section: 

Screw: 

Nut: 

Connector: 

Allen screw: 

E-clip: 

Spring: 

Washer: 

Use a Screwdriver: 

3.3 COVERS

3.3.1 FRONT COVER

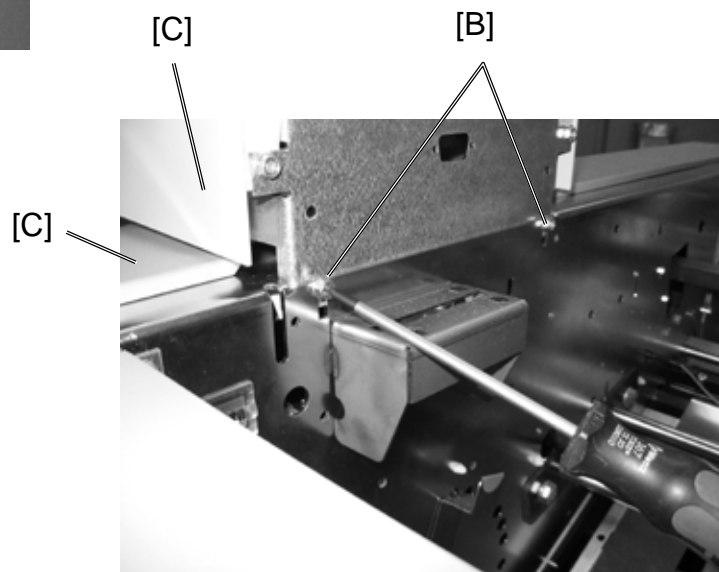
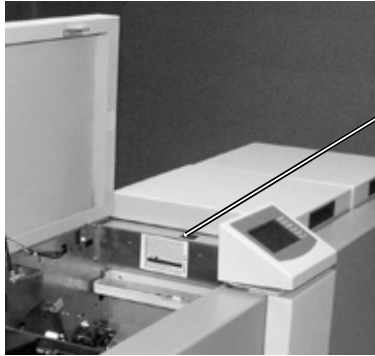

Replacement
Adjustment

Removal

1. Open the top cover.
2. Switch off the main power switch [A].
3. Loosen the screws [B] (⚙ x 2) for the operator panel. Slide the operator panel [C] to the end of the mounting slots and tighten the screws.
4. Lift up the front cover [D] and slide it out between the frame and the control panel.

Replacement

1. Reverse the removal procedure.

NOTE: Position the front castors pointing inwards under the Booklet maker before installing the Front Cover.

⚠ WARNING

Cover is very heavy and could cause injury if it falls down.

3.3.2 REAR COVER

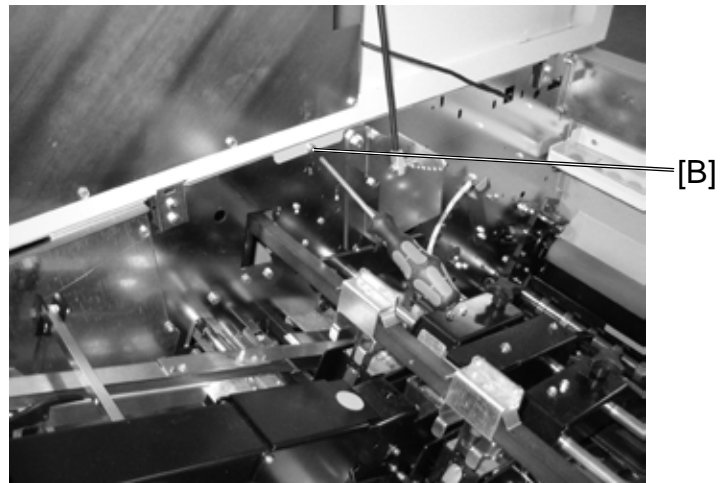
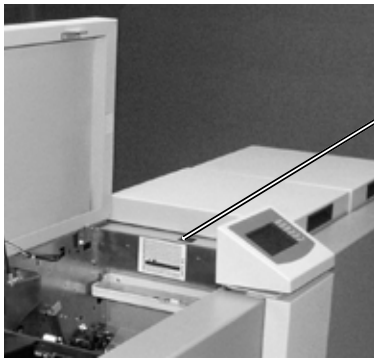

Removal

1. Open the top cover.
2. Switch off the main power switch [A].
3. Loosen the screw [B] (⚙ x 1) for the rear cover.
4. Lift up about 10 mm and remove the rear cover.

Replacement

1. Reverse the removal procedure.

⚠ WARNING

Cover is very heavy and could cause injury if it falls down.

3.3.3 INFEEED COVER

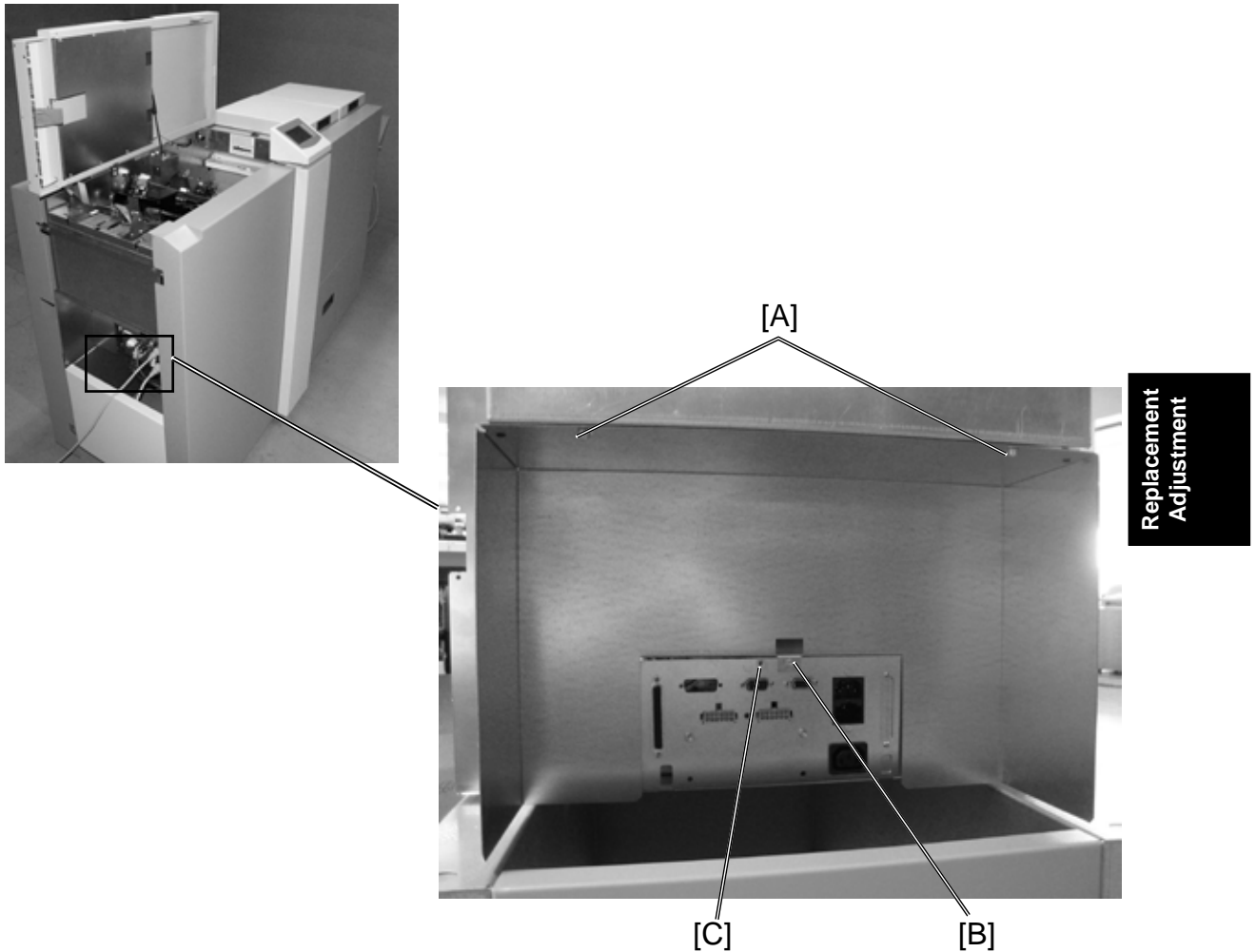

Removal

1. Remove front cover and rear cover ((3.3.1, 3.3.2).
2. Loosen the screws [A] (x 2) a few turns.
3. Remove screw [B] (x 1) and place it in the other hole [C].
4. Remove the cover.

Replacement

1. Reverse the removal procedure.

3.3.4 OUTFEED COVER

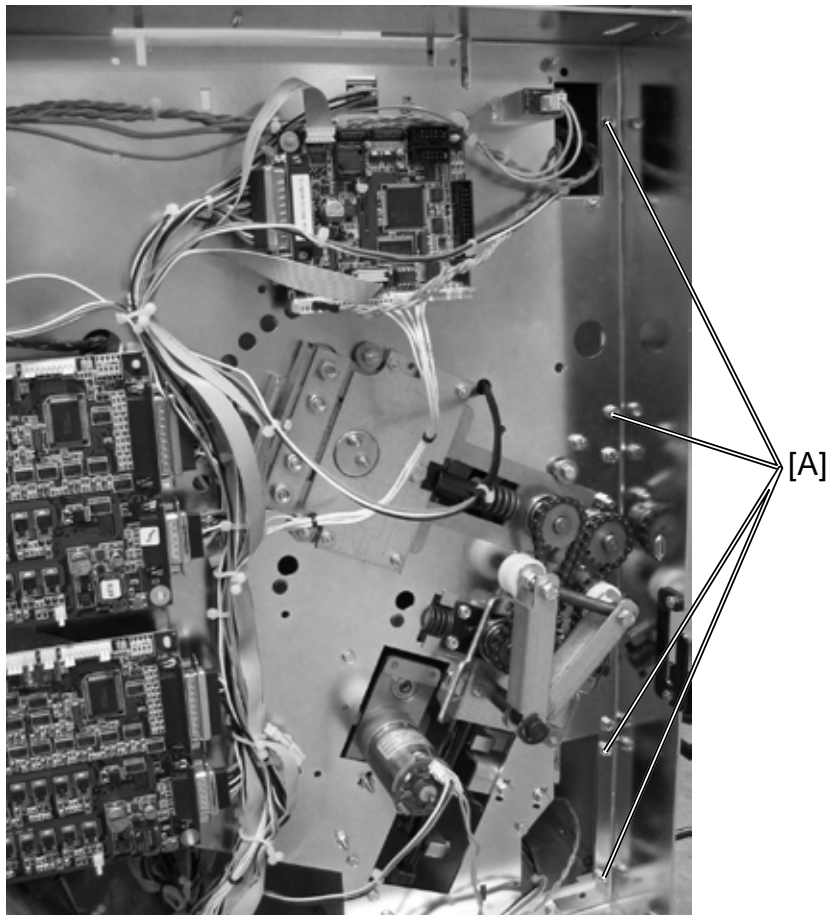

Removal

1. Remove Front and Rear cover ((👉 3.3.1, 3.3.2).
2. Remove trimmer unit if any or belt stacker ((👉 1.4.4) or ((👉 3.3.5).
3. Disconnect connector for exit sensor ((👉 3.5.14), (🔌 x1).
4. Remove eight screws [A] four on each side (🔩 x8).
5. Remove the cover.

Installation

1. Reverse the removal procedure





3.3.5 BELT STACKER



Replacement
Adjustment

[A]

Removal

1. Remove the Right cover (Front cover ( 3.3.1) or Rear cover ( 3.3.2) depending on model).
2. Disconnect connector for belt stacker ( x1).
3. Loosen screws [A] ( x2).
4. Remove belt stacker.

Installation

1. Reverse the removal procedure

3.3.6 PAPER PATH

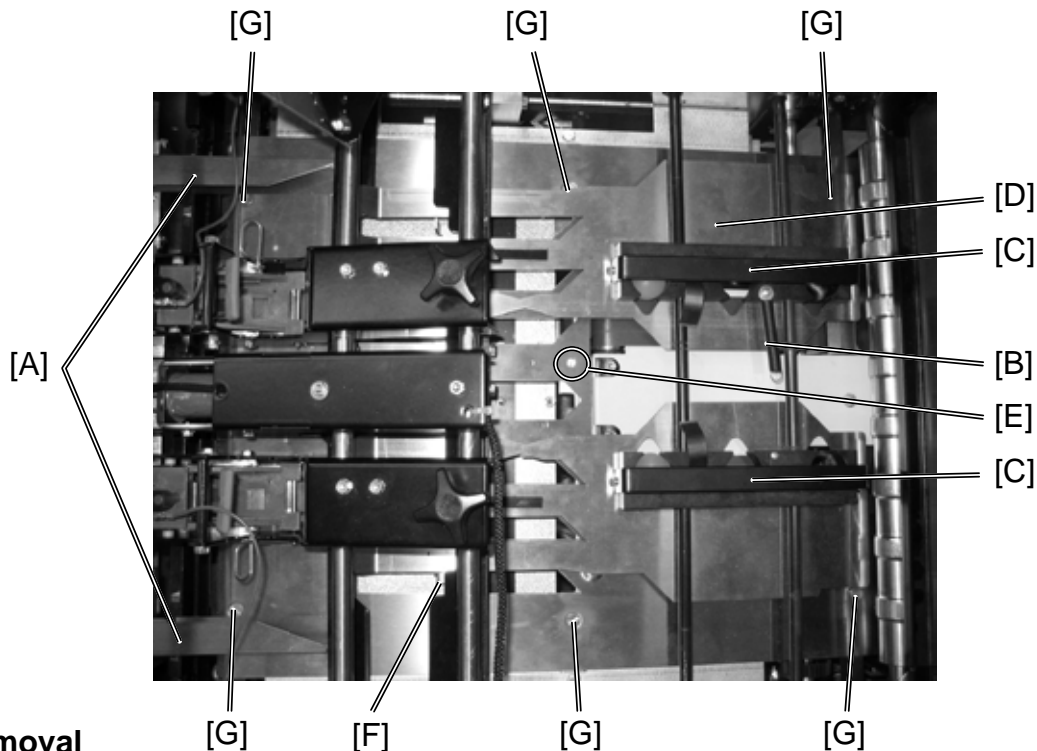

Removal

1. Remove trimmer unit if any (1.4.4).
2. Set the machine to A4 portrait – edge stapling.
3. Open top cover.
4. Move the side jogger channels [A] to the widest position.
5. Unhook the spring [B].
6. Note the position of the balls in the ball cage [C] in the pre-fold ASSEMBLIES- and remove them.
7. Install the interlock cheater.
8. Enter service mode, solenoids.
9. Activate SOL4. It will be deactivated automatically after one minute.
10. Move the left paper guide [D] so the screw [E] can be reached by holding the stop gate [F] down while moving the left paper guide [D] out (1).
11. Remove the screws [G] (6) along the paper path and the screw [E] (1).
12. Activate SOL4 again.
13. Lift up the paper path and slide it towards the fold area. Push down the stop gate and continue to slide the paper path out through the fold area.

Installation

1. Reverse the removal procedure.

CAUTION

Tighten the screws with matched screwdriver so no burrs will arise on the screw heads. Reinstall the balls in the right order and the spring.

3.4 MAIN ASSEMBLIES

3.4.1 INFEEED MODULE

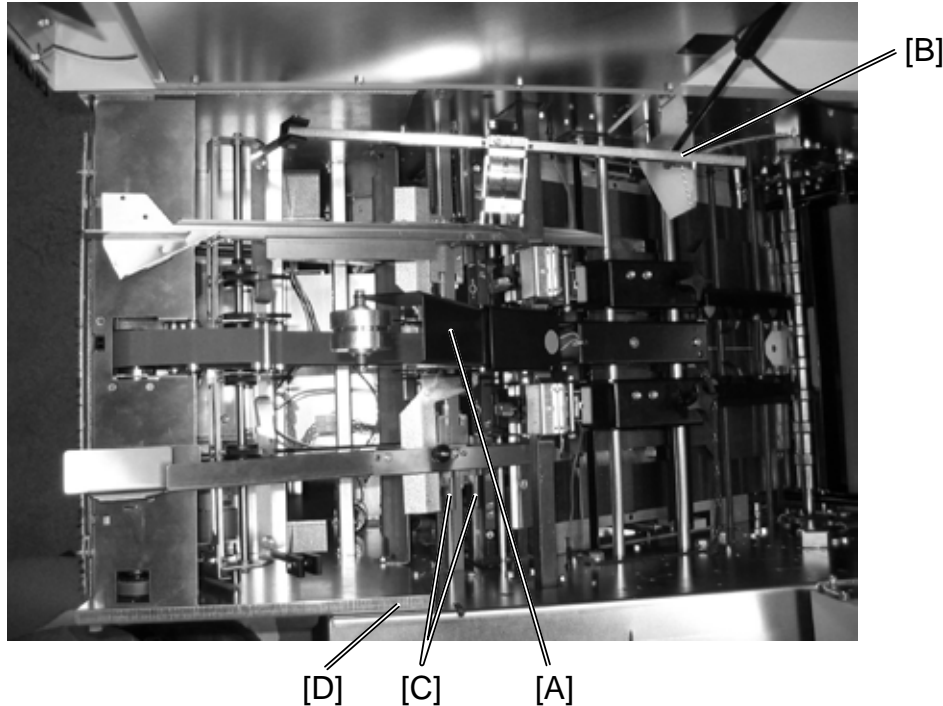

Replacement
Adjustment

Removal

1. Open top cover.
2. Switch off main power switch.
3. Hook up roller/paper guide bar to jam clearing position [A].
4. Fold away the upper idler roller shaft [B].
5. Remove side jogger channels by loosen the spacers [C] ((👉 3.4.14)).
6. Remove in-feed cover ((👉 3.3.3)).
7. Disconnect two connectors ((🔌 x2)).
8. Remove two screws M4 [D], one on each side ((🔩 x2)).
9. Lift out the in-feed module.

Installation.

1. Reverse the removal procedure.

⚠ CAUTION

Install side jogger channels according to ((👉 3.4.14)).

3.4.2 INFEED BELT

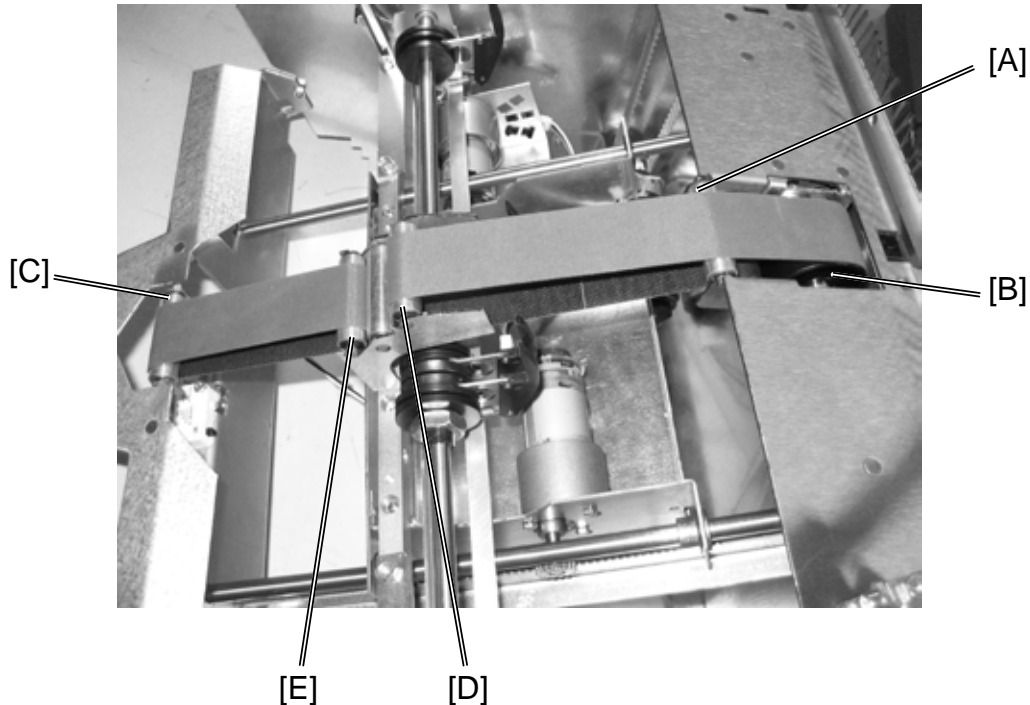

Removal

1. Remove roller assembly [A].
2. Remove the belt from the drive pulley [B].
3. Remove roller [C], [D] and [E].
4. Remove the belt.

Installation

1. Reverse the removal procedure.

Adjustment

1. If the belt doesn't run centred at the rollers, the in-feed paper path may be skewed. Adjust the paper path.
2. Check that the rollers are mounted correctly.
3. Check that the other roller brackets are mounted straight.

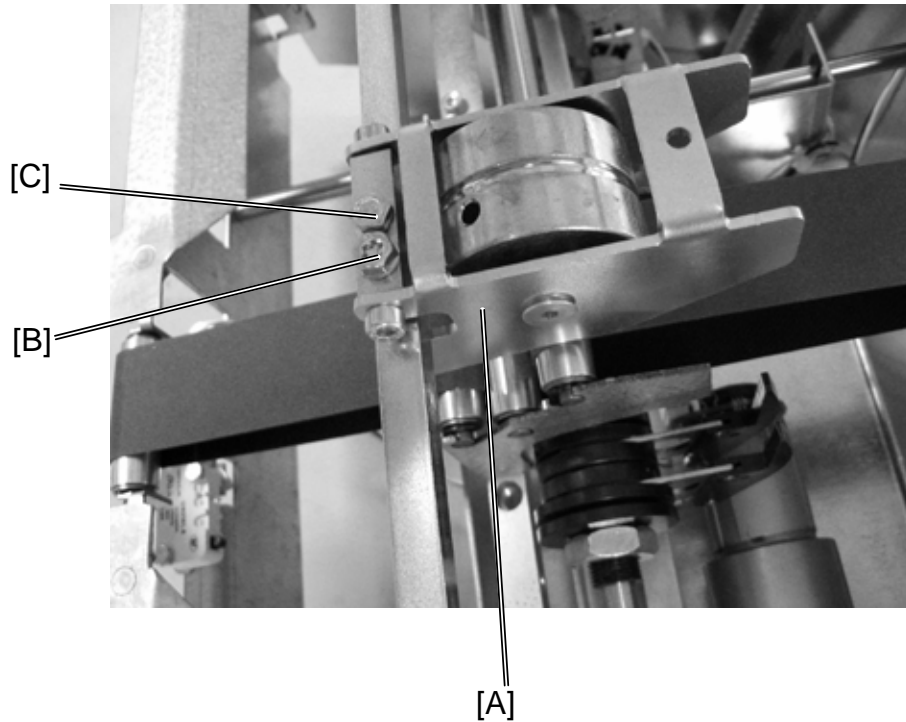

3.4.3 INFEEED ROLLER SHAFT



Replacement
Adjustment

If the roller bracket [A] is not correctly adjusted the sheets will jam against the side jogger channel.



Adjustment.

1. Loosen screw [B] ( x1).
2. Adjust bracket by turning roller bracket until the sheets enters the stapling area straight.
3. Tighten screw [B] and check that screw [C] is tightened ( x2).

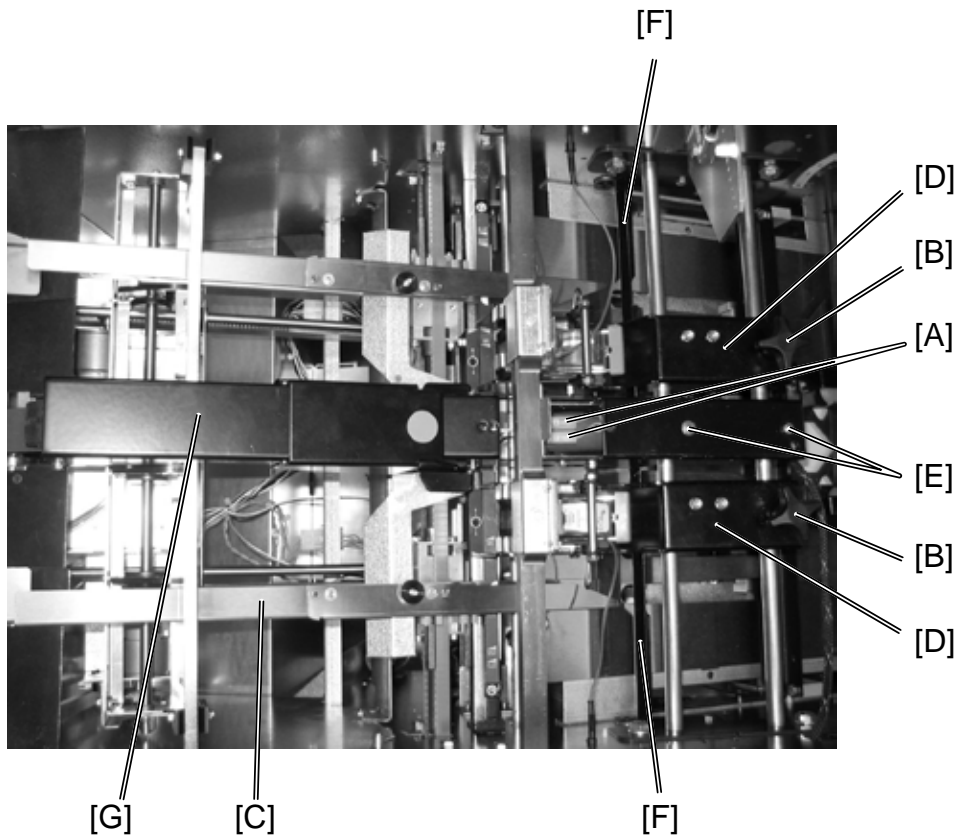
3.4.4 INFEEED IDLER ARM ASSEMBLY



Removal

1. Open top cover.
2. Switch off main power switch.
3. Disconnect the two connectors [A] for the solenoid (SOL 1) ( x2).
4. Move the side jogger channels [C] to the sides.
5. Loosen the knobs [B].
6. Move stapler assemblies [D] to the sides.
7. Remove two nuts [E] ( x2).
8. Unhook the paper guide extensions [F] from the holes in the idler arm assembly.
9. Remove the idler arm assembly [G].

Installation

1. Reverse the removal procedure.

CAUTION

Make sure the paper guide extensions [F] are properly in the holes of the idler arm assembly.

3.4.5 IDLER ARM STAPLER AREA

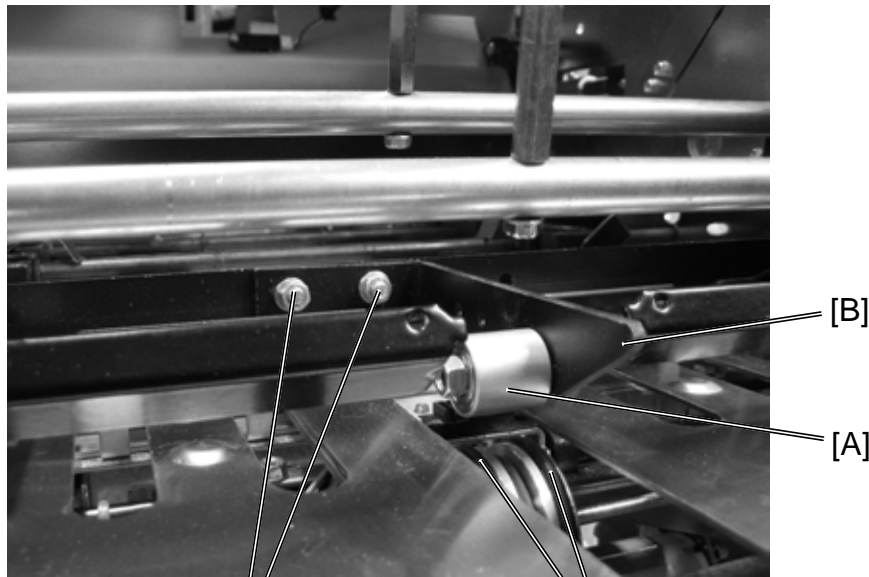

[D]

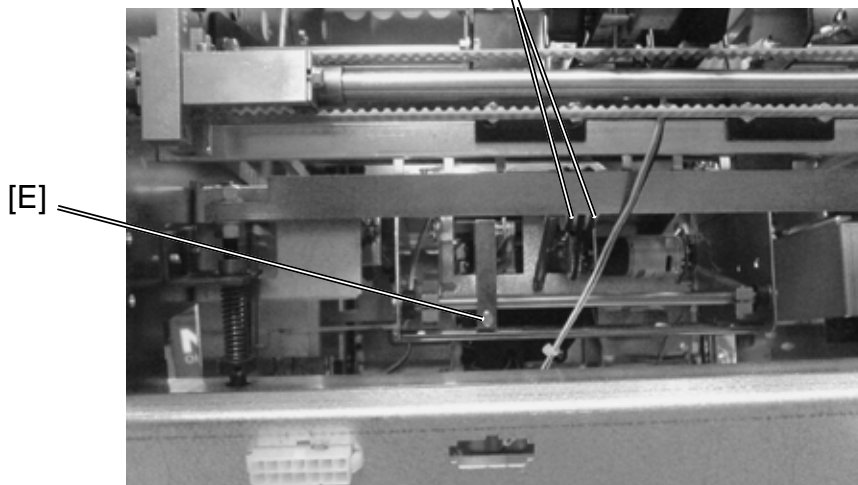

[C]



[E]

Replacement
Adjustment

Adjustment

1. Remove infeed idler arm (( 3.4.4).
2. Check that the upper idler roller [A] is $4\pm 0,5$ mm above the paper path.
3. If not, adjust distance by forming (lifting or pushing) the idler arm [B].
4. Enter service mode SOL4.
5. Check that both O-rings [C] touches the idler roller [A].
6. If not, loosen the screws [D] and adjust idler roller [A] to be parallel with O-rings [C] ( x2).
7. Check that idler arm [B] is lifted 0,5-1 mm when SOL4 is activated.
8. If not, adjust idler arm [B] by loosening screw [E] ( x1).

3.4.6 STAPLER CARTRIDGE AND STAPLER HEAD

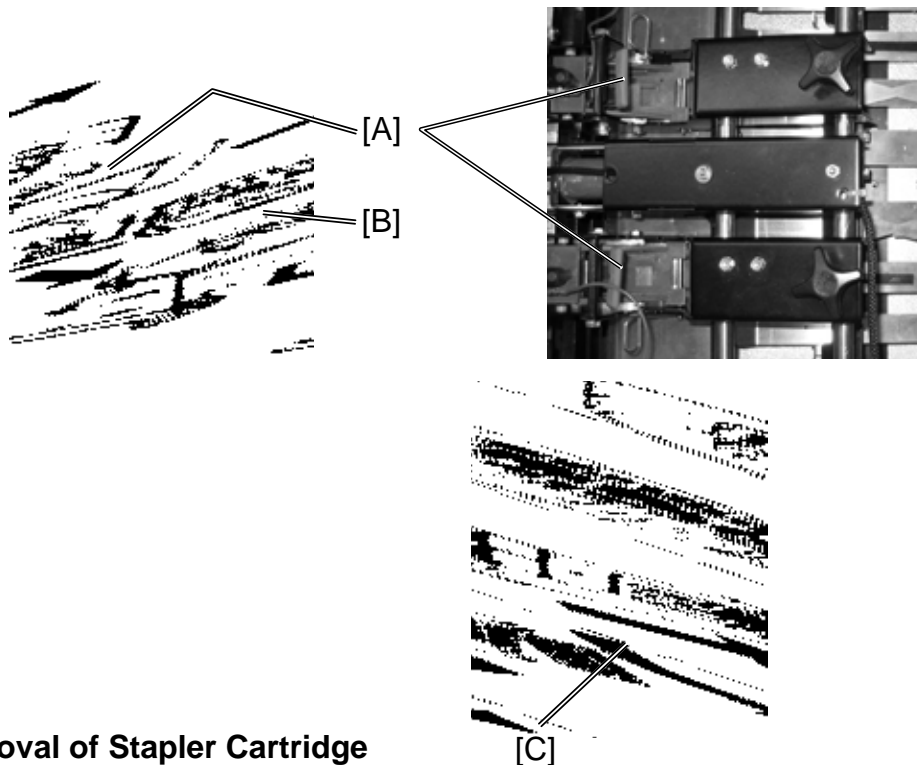

Removal of Stapler Cartridge

1. Open the top cover.
2. Raise the handle [A] on the staple cartridge locking lever.
3. Remove the staple cartridge [B] from the stapler head by sliding it away from the stapler head.
4. Renewing or reinstalling the staple cartridge, pull 25 mm / 1 inch of staples out of the cartridge and tear the staples downward against the staple tear line [C]. The staple tear line is indicated by an arrow on the side of the cartridge.
5. Insert the cartridge into the stapler head with the end of the staples facing toward the head of the stapler mechanism. Push it firmly ahead.
NOTE: Hold the staple cartridge firmly in place and push down the cartridge locking lever [A].
6. Close the top cover. Hand feed a four sheet set of paper. The booklet maker will automatically cycle and advance staples until both staple heads are driving staples. If not and/or if error message persists, repeat procedure.



3.4.6 STAPLER CARTRIDGE AND STAPLER HEAD, CONTINUES

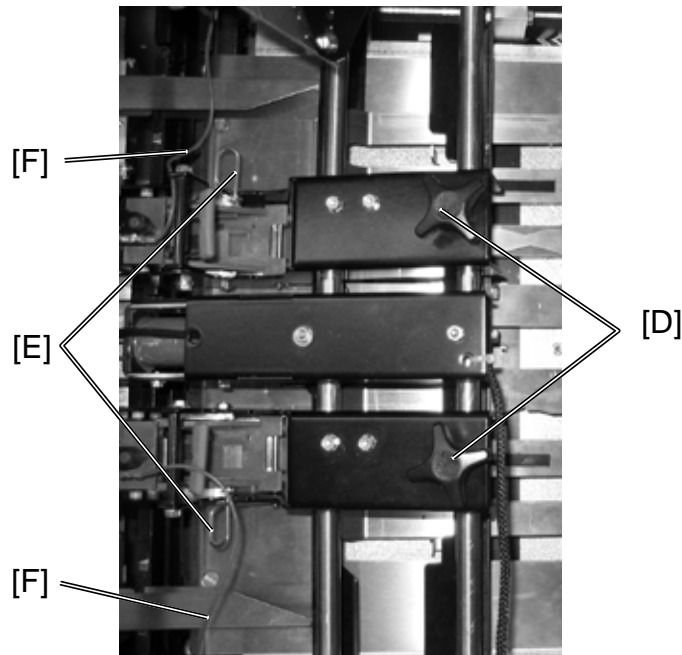

Replacement
Adjustment

Removal of Stapler Head

1. Select the A3 (11"x17") position to ensure that the side jiggers are away from the stapler head.
2. Loosen the thumb screw [D]. Rotate the lock pin [E] towards the thumbscrews and remove the lock pin from the stapler head assembly.
3. Disconnect the staple detection lead [F]. Push the stapler head towards the in-feed side, out of the stapler head assembly.

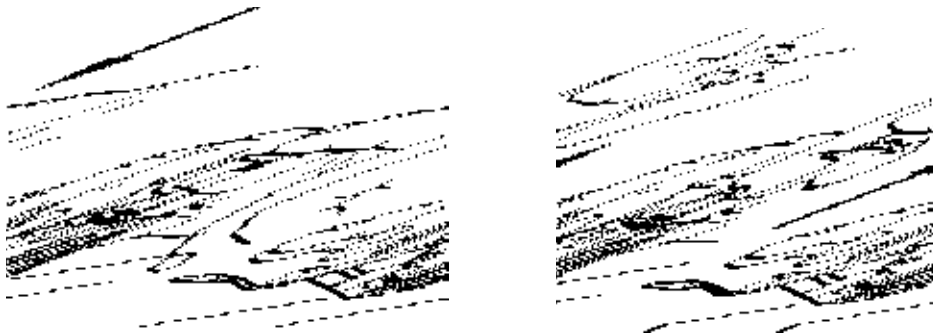

3. Remove staple cartridge. Look inside stapler head to locate jammed staples by eject point. Remove staples if any.
4. Position the stapler head on the edge of a firm surface (for example the top of a table).
5. While securely holding the head, actuate the stapler up and down through full travel. Perform this operation first without staple cartridge, then with staple cartridge. Repeat this a few times to ensure that the staples are ejected at each down movement.

Continued on next page....

3.4.6 STAPLER CARTRIDGE AND STAPLER HEAD, CONTINUES

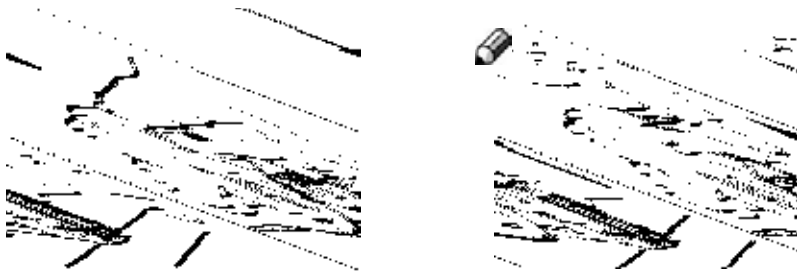

Note: When a stapler head is removed, be sure to manually eject some staples before replacing it in the BM 2000. To do this, rest the stapler head on a firm surface (for example, the top of a table) and actuate the staple driver post up/down through full travel. Do this a number of times to ensure that the staples are ejected on each down movement. If you need to change the staple cartridge, see previous section, removal/replacement of staple cartridge.

⚠ WARNING

When manually ejecting the stapler, stay clear from stapler output area.

Maintenance

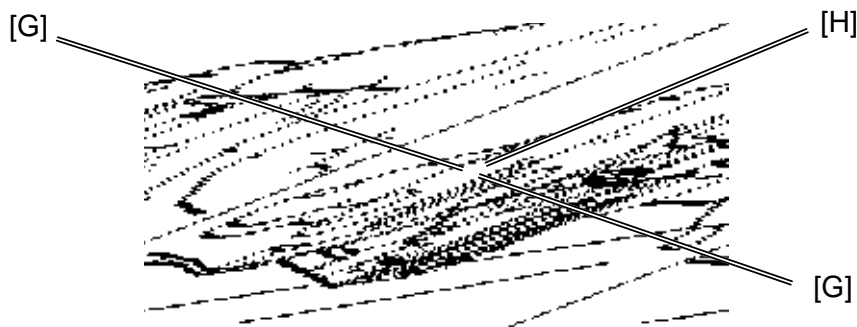

The stapler head drive post on each stapler head should be lubricated every 20 00 cycles.

1. Put a couple of drops of oil [G] on each side of the drive post [H].
2. Cycle the stapler head a few times before installing it again.

⚠ WARNING

When manually ejecting the stapler, stay clear from stapler output area.

3.4.6 STAPLER CARTRIDGE AND STAPLER HEAD, CONTINUES

Installation

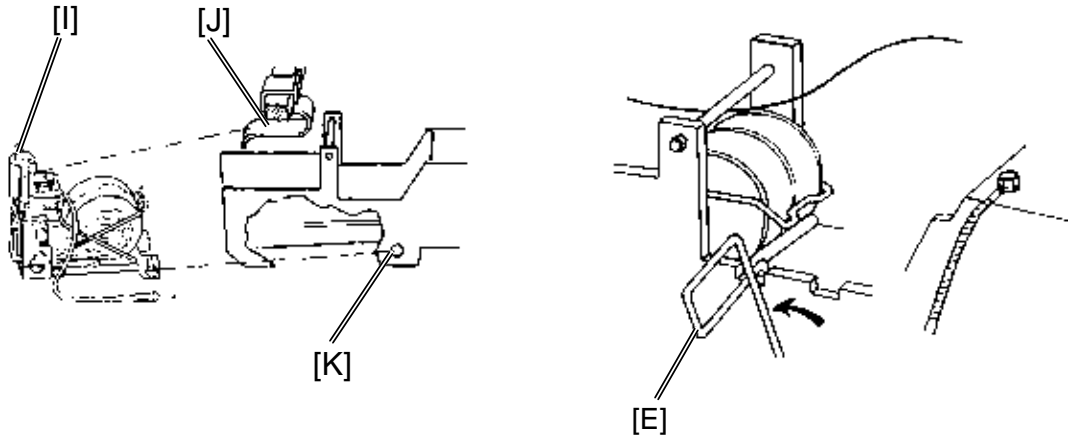

Replacement
Adjustment

1. Before inserting the stapler head, centre the stapler lift bracket [J] over the area that will receive the stapler head. Ensure that the staple driver post [I] is in its uppermost position.
2. Place the stapler head back into the BM 2000. The driver post arm [I] must be placed into the stapler lift bracket [J].

⚠ CAUTION

If the driver post arm is not correctly positioned into the stapler lift bracket [X] it will cause permanent damage to the stapler head as well as the bracket. Subsequently, also future correctly mounted stapler heads will be damaged.

3. Press on the lower front edge of the stapler head to align the hole [K] in the stapler bracket with the hole in the stapler head. Insert the lock pin [E] so that it engages the stapler head and the metal sides of the stapler assembly.
4. Lock the pin [E] by rotating it towards the in-feed side. Check that the stapler head is correctly mounted by pushing the stapler head towards the infeed area. If it gets loose, it is not correctly mounted.
5. Insert the staple detection lead [F] into its outlet.

3.4.7 STAPLER ASSEMBLY

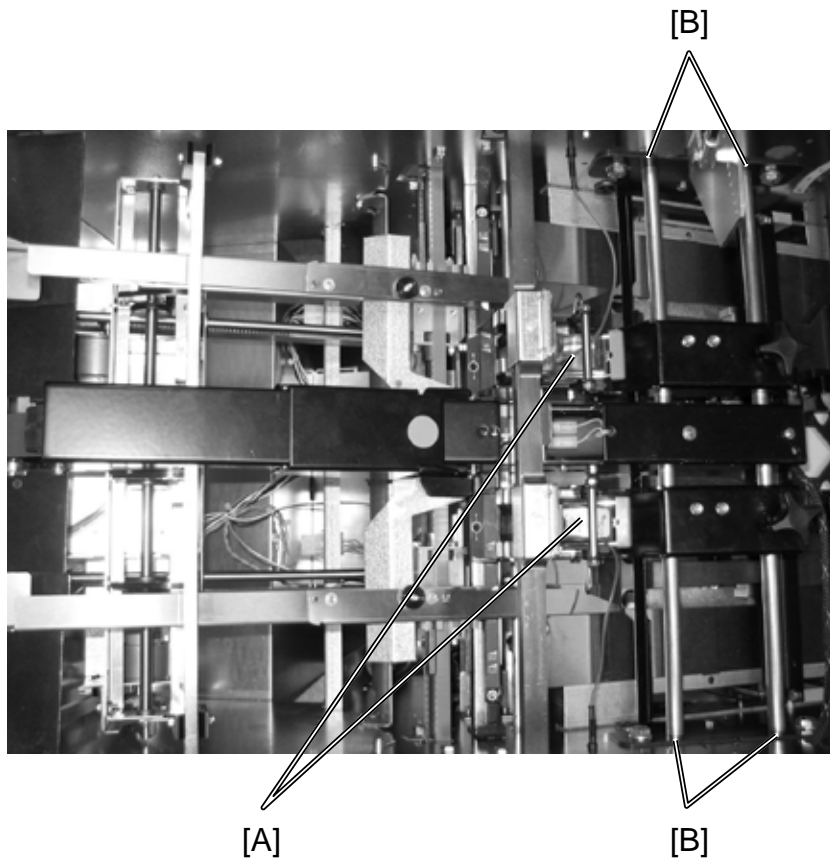

Removal

1. Remove Front and Rear cover ((👉 3.3.1, 3.3.2).
2. Remove in-feed idler arm assembly ((👉 3.4.4).
3. Remove the stapler heads [A].
4. Remove the four screws (two on each side) for the rods [B] (🔩 x4).
5. Remove the stapler assembly.

Installation

1. Reverse the removal procedure

⚠ CAUTION

Do not loosen the red painted screws.

3.4.8 STAPLER DRIVE, STAPLING POSITION (LOWER)

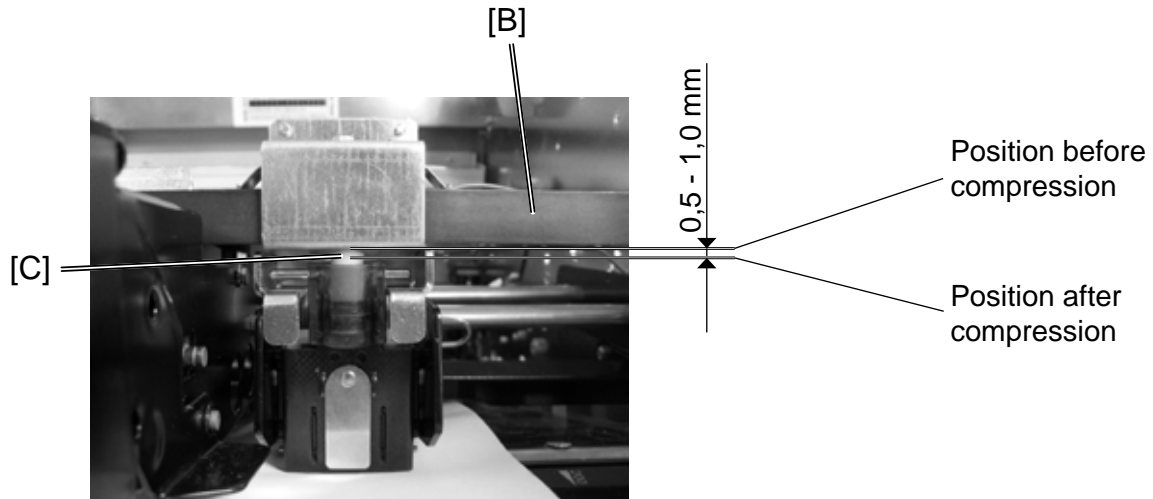

Replacement
Adjustment

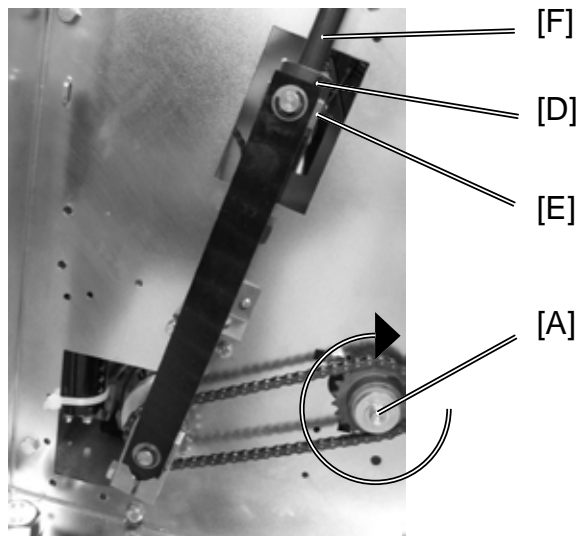

Check

1. Insert two sheet of paper in the stapler area.
2. With pliers, hand crank (clockwise) [A] the stapler/clincher drive shaft [B] to the lowest position. The picture shows the upper position.
3. At the lowest position of the stapler bar, the plunger caps [C] on the staplers should compress 0,5-1 mm to ensure correct stapling force.

Adjustment

1. Adjust lower position of the stapler bar by loosening the set screws [D] and moving the bar [E] (⚙ x2) on the stapler drive bar [F].

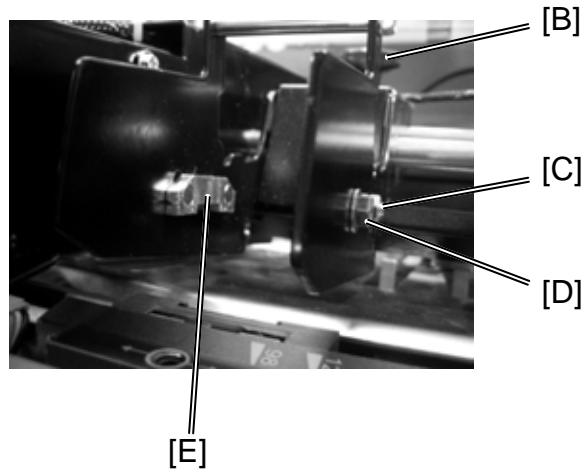
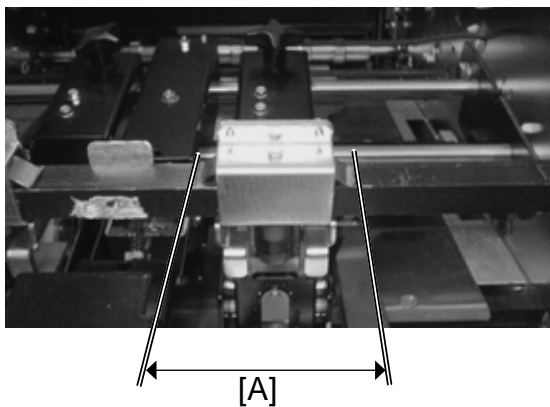

3.4.9 STAPLER DRIVE, HOME POSITION (UPPER)



Check

- 1 From top position, hand crank the stapler/clincher drive shaft a $\frac{1}{4}$ turn according to ( 3.4.8), item 2.
- 2 Measure the distance [A] with a calliper from one end to the other.
- 3 Hand crank the stapler/clincher drive shaft back to the top position.
- 4 Measure the distance [A] again with a calliper from one end to the other. The difference should be $1 \pm 0,5$ mm.

Adjustment

- 1 Hand crank the stapler/clincher drive shaft a $\frac{1}{4}$ turn according to ( 3.4.8), item 2.
- 2 Loosen the knobs [B] for the stapler brackets and move the stapler heads out a little so it will be easier to reach the nuts [C] and [D].
- 3 Tighten the knobs [B] and then loosen them one turn.
- 4 Loosen the four nuts [C] and [D] for each stapler bracket two on each side ( x4).
- 5 Move the stapler stops [E] two on each stapler bracket down as far as it will go, and tighten the nuts [D] ( x4).
- 6 Measure the distance [A] with a calliper from one end to the other.
- 7 Tighten the knobs [B].
- 8 Hand crank the stapler/clincher drive shaft back to the top position.
- 9 Measure the distance again [A] with a calliper from one end to the other. The difference should be $1 \pm 0,5$ mm.
- 10 If the distance is bigger than 1,5 repeat the procedure. In this case the knob should only be loosened $\frac{3}{4}$ turns.
- 11 If the distance is smaller loosen the knob 1 $\frac{1}{4}$ turns.
- 12 Tighten the nuts [C].

3.4.10 CLINCHER TIMING

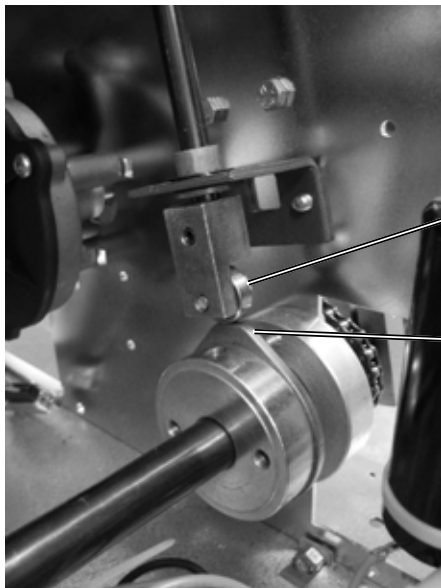

[A]

[B]

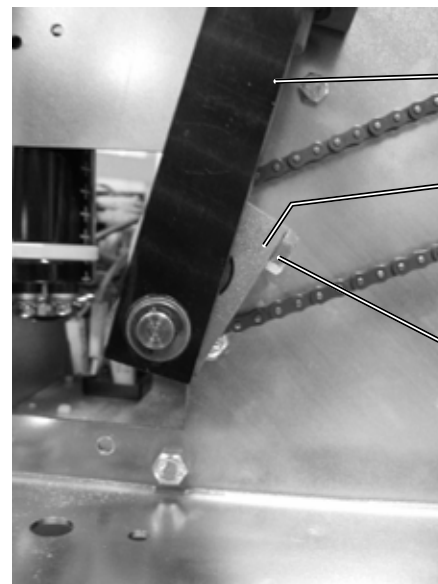

[D]

[C]

[E]

Replacement Adjustment

Removal

1. Remove in-feed cover ((👉 3.3.3)).

Installation

1. Reverse the removal procedure

Adjustment

1. Position the roller bearing [A] on the clincher drive bar on top of the clincher cam lobe [B].
2. Make sure that the crank [C] and link arm is [D] is positioned as shown in figure on both sides.
3. Adjust angle of crank [C] if necessary by loosening screw [E].

3.4.11 CLINCHER HEIGHT

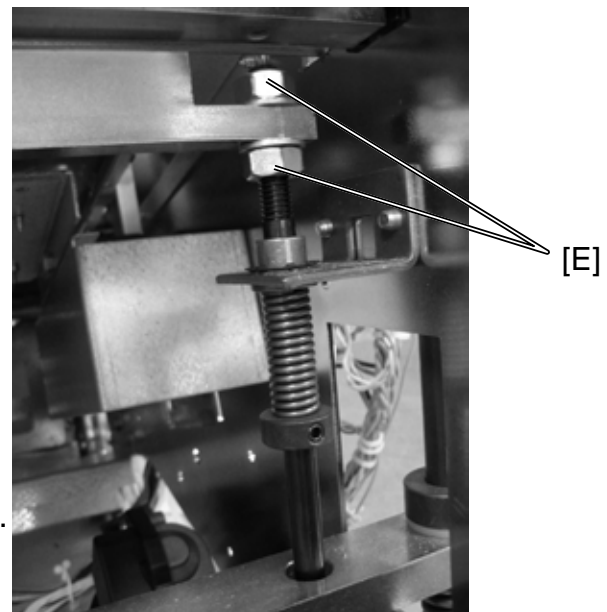
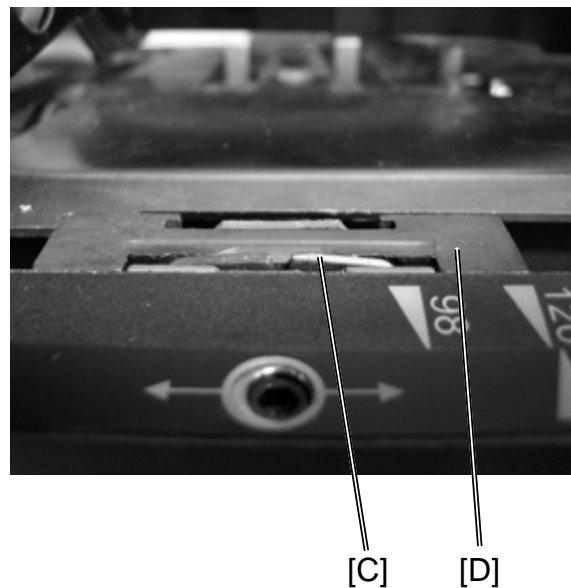
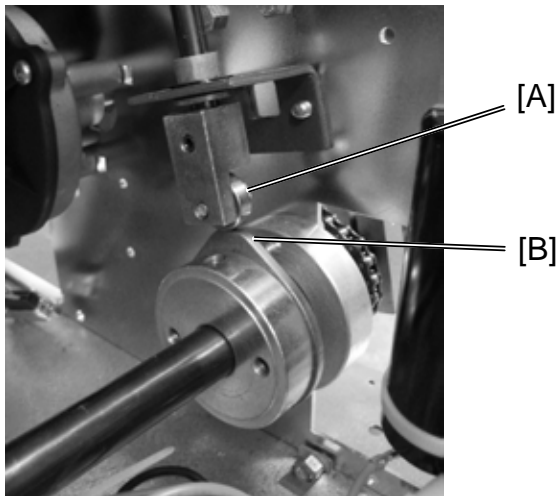

Removal

1. Remove in-feed module (([REDACTED] 3.4.1).

Installation

1. Reverse the removal procedure

Adjustment

1. Position the roller bearing [A] on the clincher drive bar on top of the clincher cam lobe [B].
2. Check that the clincher fingers [C] are flush with the top surface of the clincher bracket [D] within 0,1 mm.
3. Adjust the height by adjusting the nuts [E] on the clincher drive bar ([REDACTED] x2).
4. Check that the roller bearing runs parallel on the cam.

3.4.12 CLINCHER ASSEMBLY

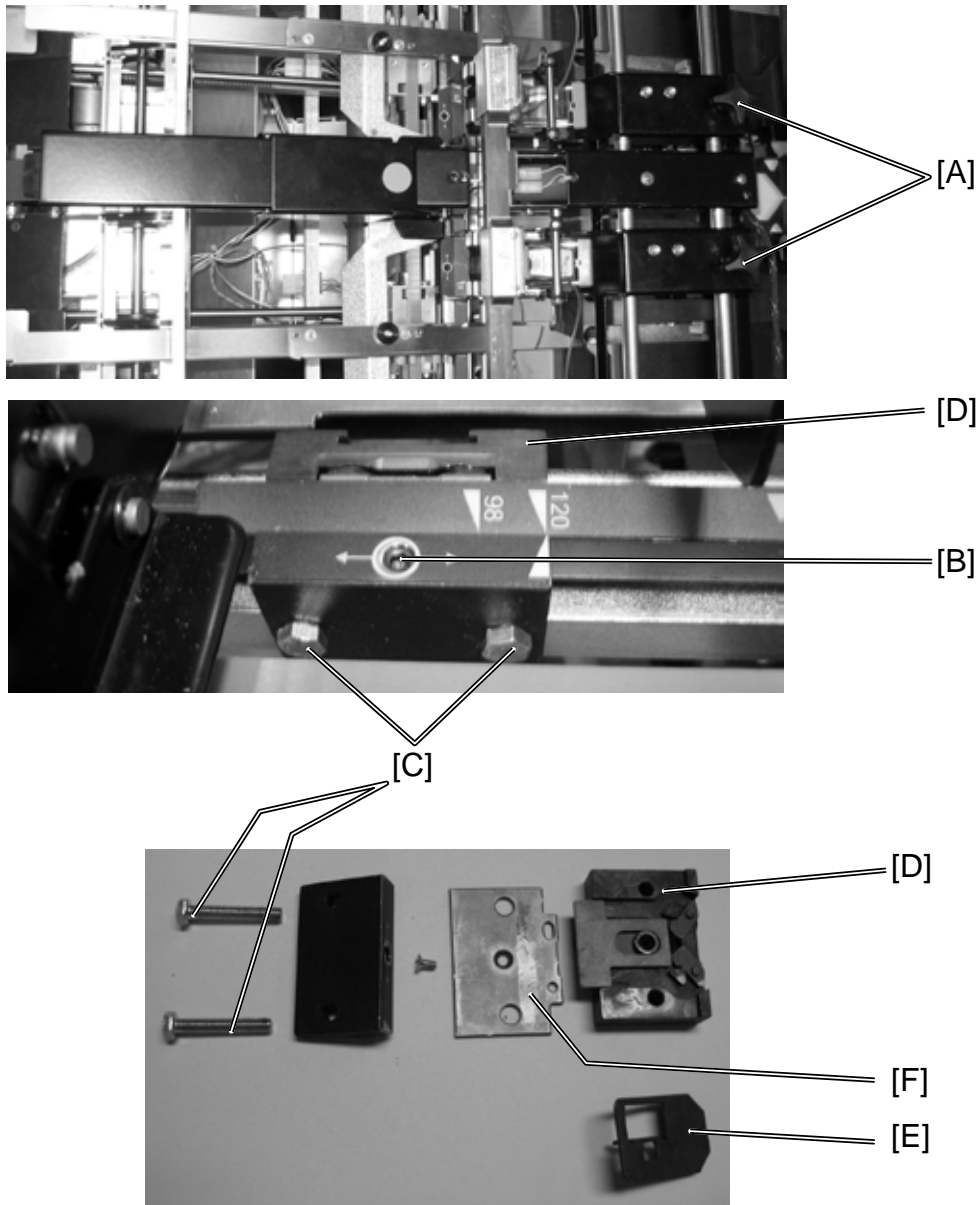

Replacement Adjustment

Removal

1. From the control panel, select A3 or 11"x17" size.
2. Loosen the knob [A] move the stapler assembly away from the clinchers.
3. Loosen the allen screw [B] 3mm, a half turn (⚙ x1).
4. Remove the two screws [C] while holding the clincher bracket [D] (⚙ x2).
5. Carefully lift out the bracket [D] with the paper stop for edge stapling [E].

⚠ CAUTION
Do not alter positions of the components.

Continued on next page....



3.4.12 CLINCHER ASSEMBLY, CONTINUES

Maintenance

1. Remove the retaining plate [F].
2. Clean the components of the clincher.
3. Check for wear and burrs. If any sign of wear or burrs the clincher assembly must be replaced.
4. Lubricate all components with thin oil.

⚠ CAUTION
Do not alter positions of the components.

Installation

1. The screws [C] should be tightened so there is no play between clincher bracket and the clincher bar ( x2).
2. Reposition the clincher assembly to correct position (normally 120 mm) and tighten the screw [B] ( x1).

3.4.13 SIDE JOGGER DRIVE

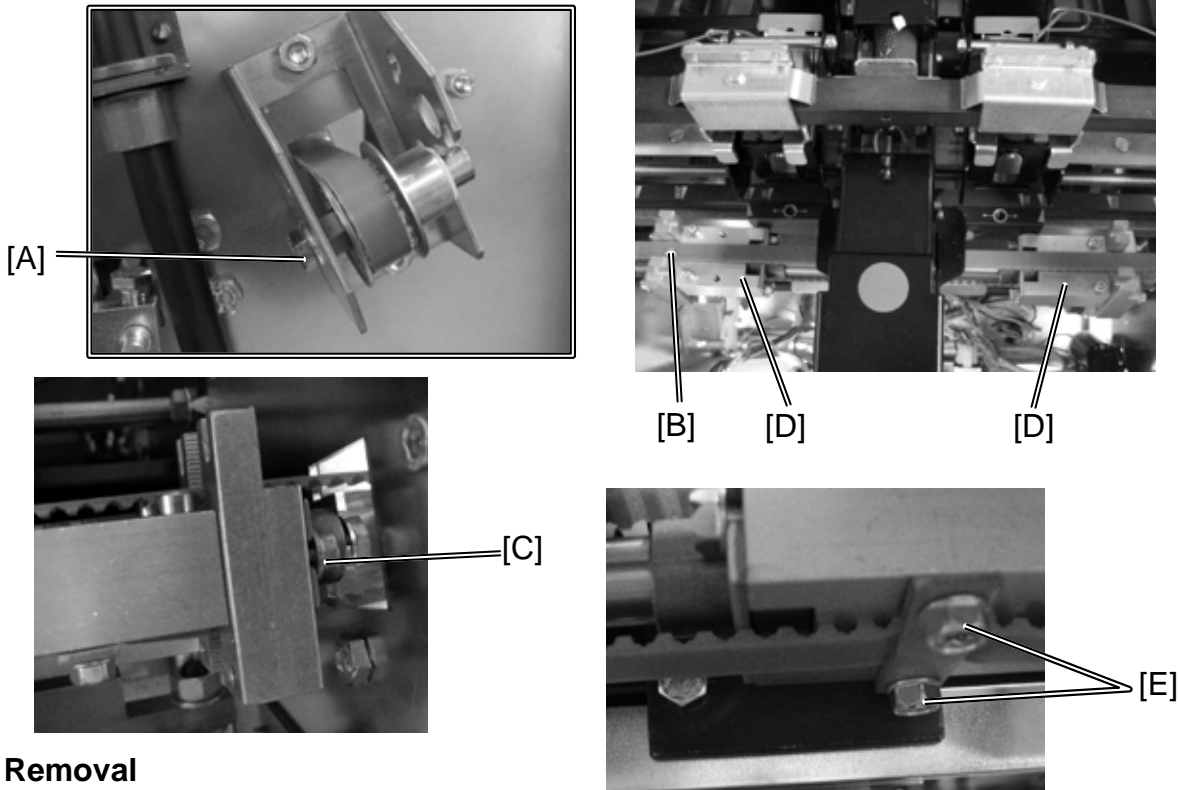

Removal

1. Remove in-feed module ((🔧 3.4.1).
2. Remove side jogger motor M4 ((🔧 3.6.4)
3. Remove tension pulley [A].
4. Remove screw for timing belt [B] (🔧 x1).
5. Loosen two screws [C] at the end of the side jogger shaft and lift out the jogger assembly (🔧 x2).

Installation

1. Reverse the removal procedure

Adjustment

1. When tightening the screws [C] make sure that the shaft is mounted at the end of the slots (🔧 x2).
2. Check that both side jogger channel mounting brackets [D] are centred in the machine. Move the side jogger channel brackets all the way out. They should touch the right and the left frame at the same time.
3. If not loosen the two screws [E] for the belt clamp bracket and move both jogger channel brackets until they stops against the frames. Tighten the screws [E] (🔧 x2).

3.4.14 SIDE JOGGER CHANNELS

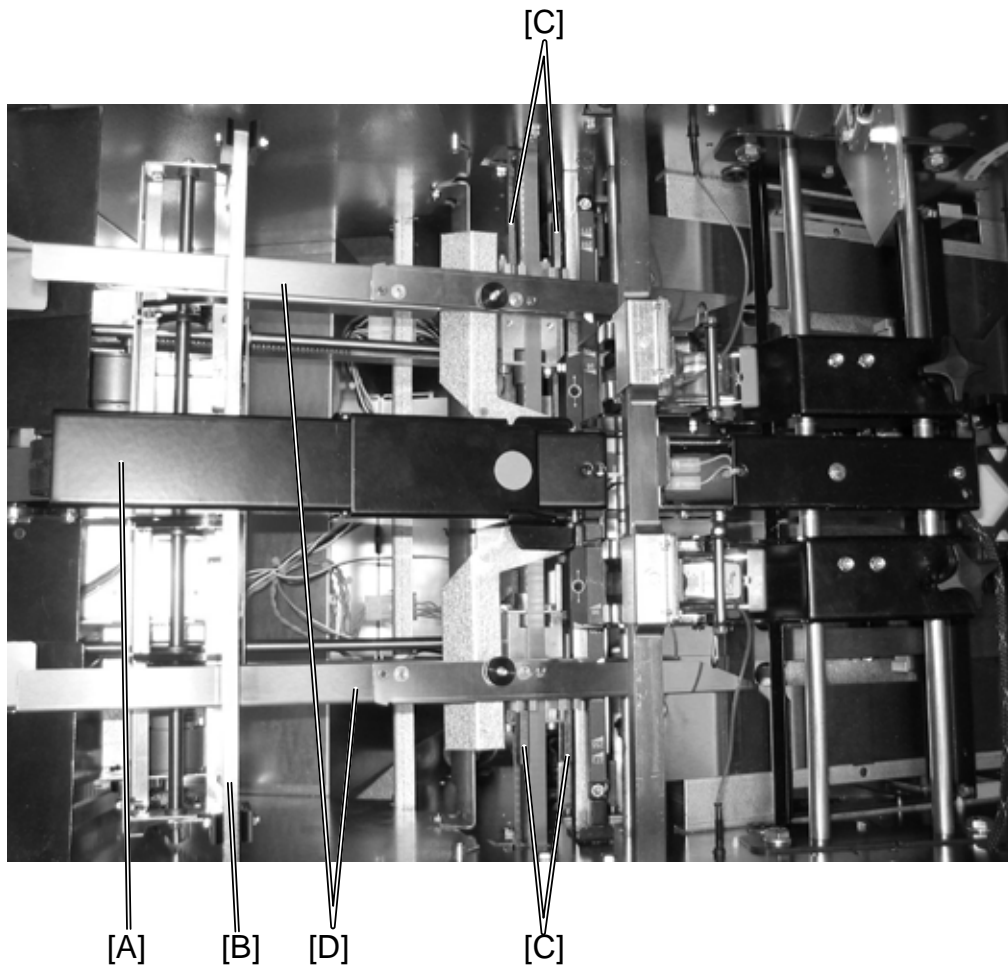

Removal

1. Lift and hook up Idler arm assembly [A].
2. Raise the upper in-feed roller shaft [B]. See picture ((👉 3.4.3)).
3. Loosen the spacers [C], two at each side jogger channel [D].
4. Lift out the side jogger channel.

Installation

1. Reverse the removal procedure.

⚠ CAUTION

When installing the side jogger channels ensure that the small bracket on the side jogger channel [E] comes under the in-feed paper path and the side jogger guide [F] will fit in the groove in the outer jogger finger. The side joggers should be mounted tight to the hex screw heads (adjustment screws). Two on each side [G].

Continued on next page....

3.4.14 SIDE JOGGER CHANNELS, CONTINUES

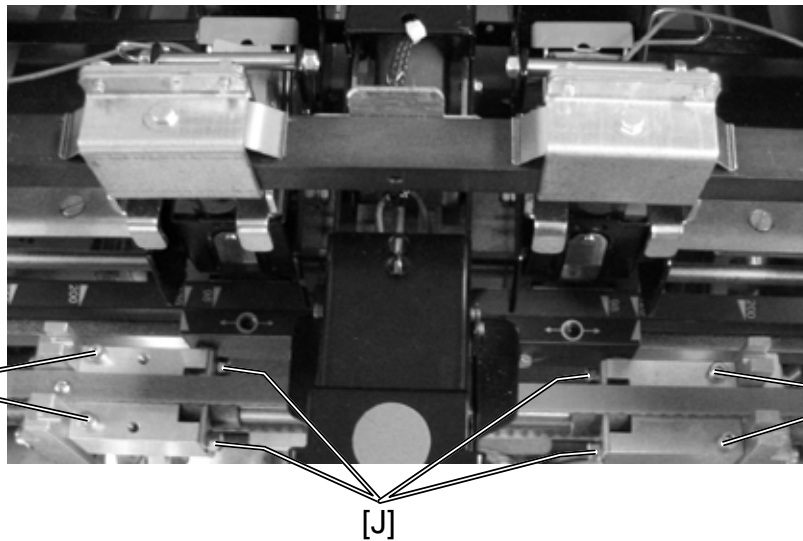
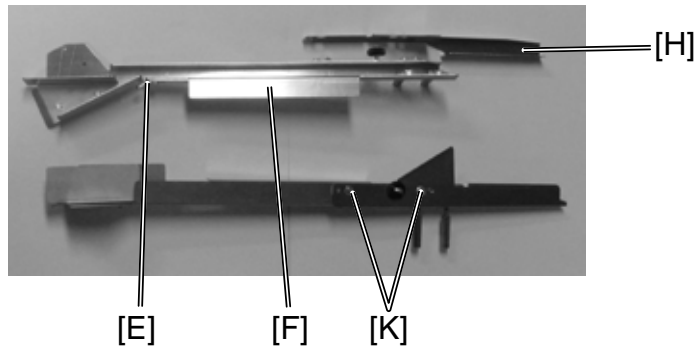

Replacement Adjustment

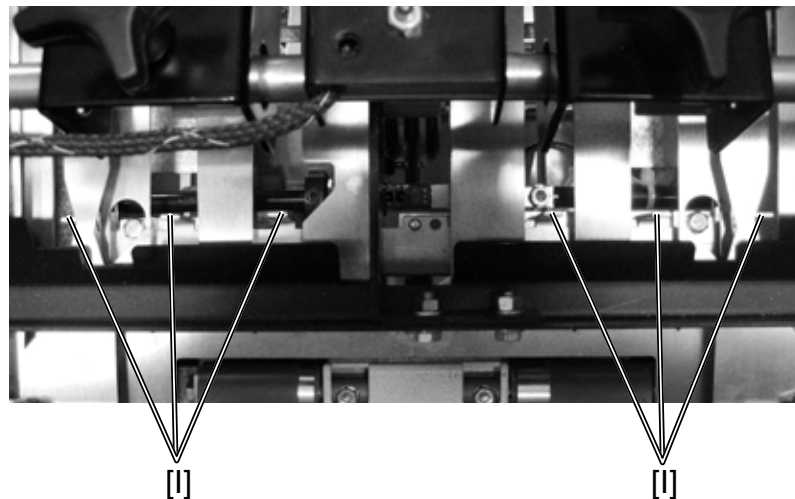



Adjustment, alignment

1. Set the machine for A3 or 11"x17".
2. Remove the side jogger channel extensions [H] on the side jogger channels.
3. Insert an A3 or 11"x17" heavy stock paper in the stapler area against the stop gate [I]. Make sure that the paper is 90° in the corners. Special adjustment tool (template) is available.

Continued on next page....

3.4.14 SIDE JOGGER CHANNELS, CONTINUES

4. Turn the timing belt pulley on the side jogger motor M4 so the side jogger channels touch the edges of the paper or template.
5. If the side jogger channel isn't parallel to the paper or template it has to be adjusted.
6. Loosen two screws [J], on the side jogger mounting bracket ( x2).
7. Turn the timing belt pulley on the side jogger motor M4 so the side jogger channels touch the edges of the paper or the template.
8. Tighten the screws [J] ( x2). Check again.
9. Mount the side jogger channel extensions [H] and turn the pulley on the motor again.
10. Turn the timing belt pulley and check that the lowest point at the side jogger extension is parallel to the side jogger channel.
11. If not, loosen the two nuts [K] and adjust it to be parallel ( x2).

Adjustment, height

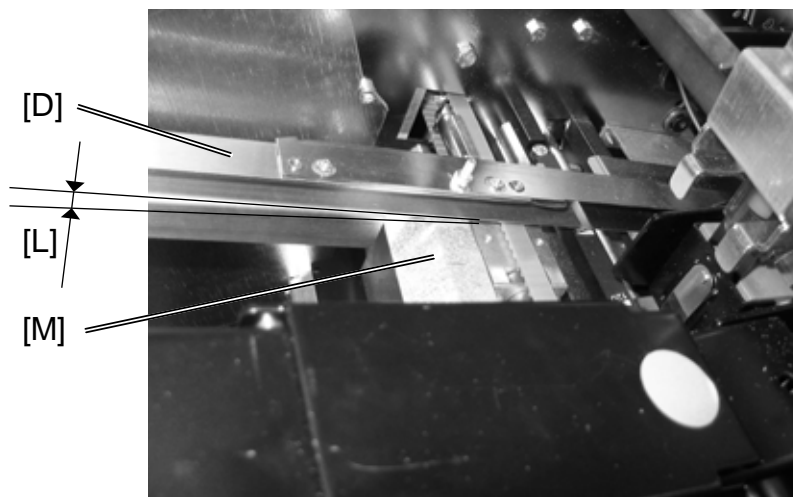

There should be a 1-2 mm distance [L] between the side jogger channels and the roller bracket [M]

1. Remove the side jogger channel [D].
2. Adjust the height by turning the screws [G]. Both screws on each side should be adjusted within 0,5 mm. One turn on the screws equals 0,7 mm. Turning clockwise decreases the space between the side jogger channel and the roller bracket.
3. Install the side jogger channel.

3.4.15 REAR JOGGER FINGERS

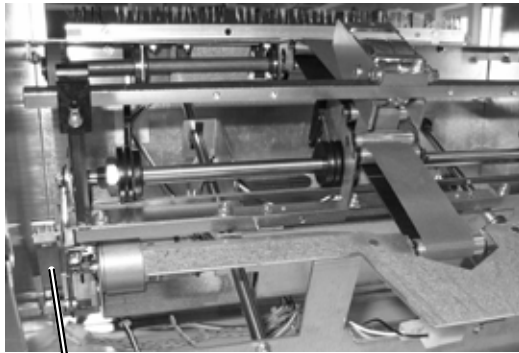

[A]

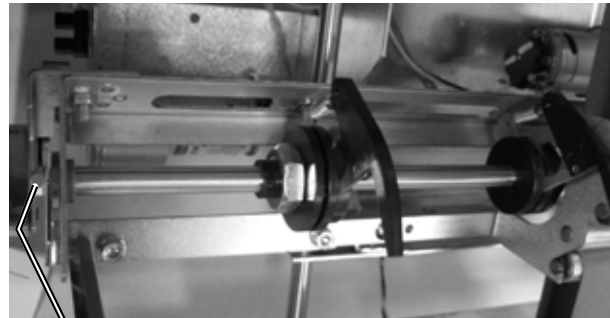

[B]

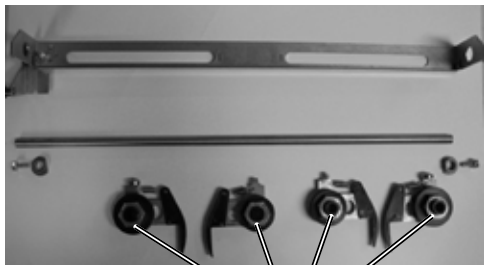

[C]



[C]



[F]

[E]

[D]

Replacement
Adjustment

Removal

1. Run M3 in service mode down to the home switch.
2. Remove in-feed module (see 3.4.1).
3. Snap out the link between the motor and the jogger assy [A] at the jogger assy .
4. Loosen screws [B], one at each side of the shaft ( x2). Only one screw is shown.
5. Lift out the shaft assy.
6. Remove the jogger fingers.
7. Remove the nuts [C] ( x4).
8. Remove the plastic washer [D] and the bearing [E] on the outer fingers ( x1).
9. Replace jogger finger assembly [F].

Installation

1. Use new plastic washers for the outer fingers.
2. Don't tight the nuts to hard which can make it bind on the shaft. Plastic bushings must move freely on the shaft.

3.4.16 REAR JOGGER ALIGNMENT

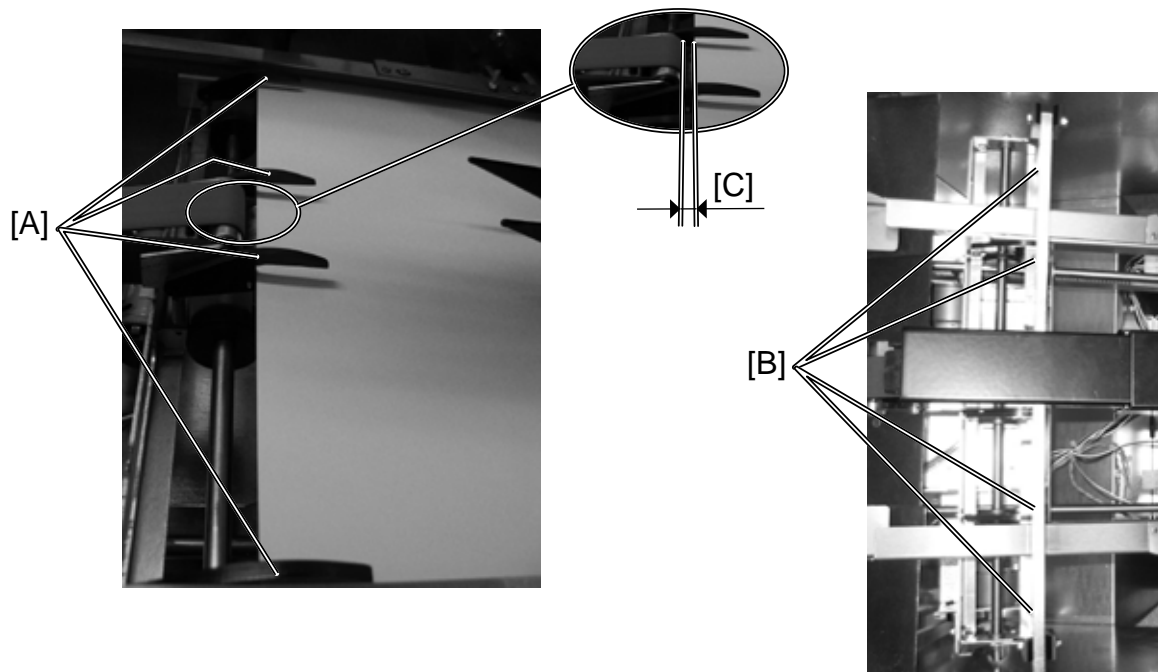

Purpose

The jogger fingers [A] must be parallel with the trail edge of the paper.

Adjustment

1. Set the machine to A3 or 11"x17".
2. Enter service mode. Motors.
3. Open the top cover and insert the interlock cheater.
4. Insert an A3 or 11"x17" paper in the stapler area against the stop gate.
5. Run back jogger motor M2 "Up" position.
6. Run back jogger poisoning motor M3 "Cycle2" (down) until the jogger fingers touches the paper. Continue to run approximately 5 mm (The paper will curl).
7. Run M3 "Cycle1" ((up) until the fingers are leaving the paper. All fingers should leave the paper (parallel to the paper) at the same time.
8. If the fingers are not parallel to the edge of the paper loosen the 4 screws [B] ( x2). Adjust the bracket until fingers are parallel to the edge of the paper.
9. Check that the distance between the in-feed belt roller and the paper [C] is 3-4 mm. If that distance could not be obtained the in-feed roller bracket must be adjusted. The screws are placed under the roller.

3.4.17 FOLD ROLLER, LOWER

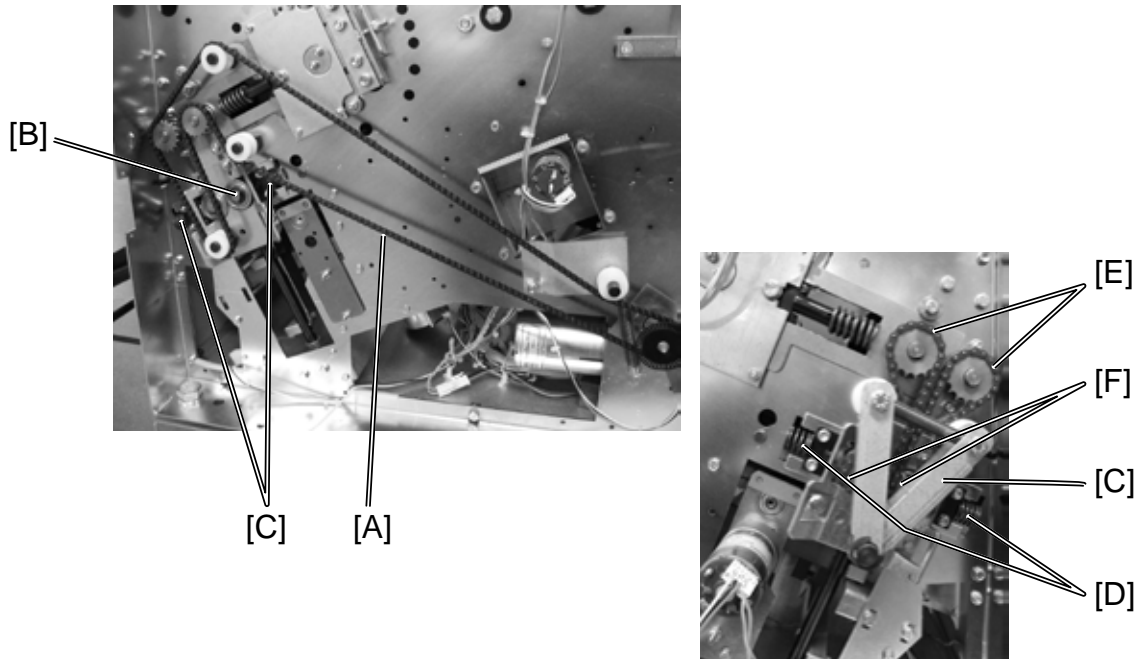

Replacement
Adjustment

Removal

1. Remove outfeed cover ((👉 3.4.4)
2. Remove chain [A].
3. Remove the two retaining rings [B] (ⓐ x2).
5. Remove the tension arm assembly [C].
4. Remove the four springs [D].
NOTE: Use a screw driver as a lever between spring bracket and bearing bracket to release the spring tension.
6. Remove the two chains [E].
7. Remove the two lower sprockets [F].
NOTE: There are shim washers by the sprockets. Note their position and quantity for installation.
8. Lift up the paper guide between lower and upper fold rollers.
9. Pull out the fold roller through the inside of the machine.
10. Pull out the other fold roller through the fold area of the machine.

Installation

1. Reverse the removal procedure

3.4.18 FOLD ROLLER, UPPER

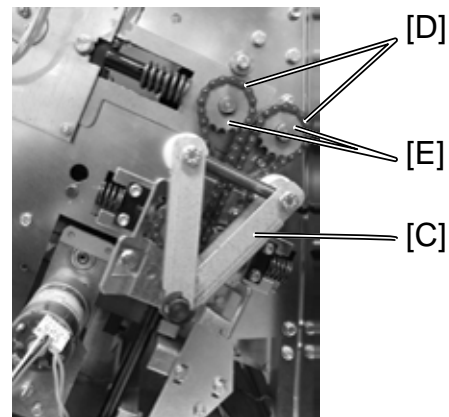
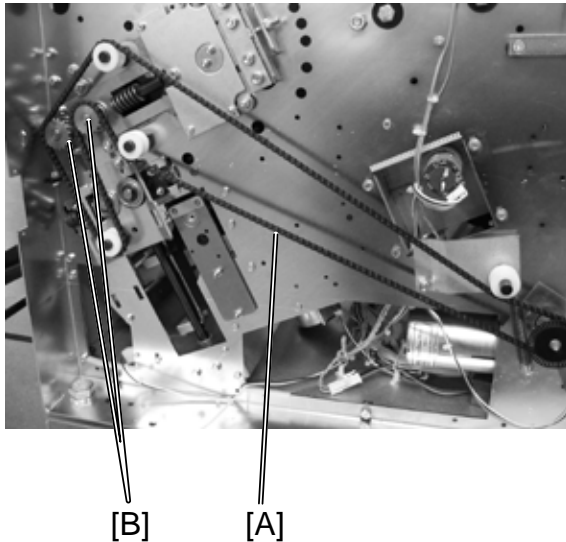

Removal

1. Remove Front and Rear cover (( 3.3.1, 3.3.2).
2. Remove chain [A].
NOTE: Open the top cover and move the green pressure handles in a different position to release/unrelease the spring tension.
3. Remove the upper sprockets [B].
4. Remove the tension arm assembly [C].
5. Remove the two chains [D].
6. Remove the two upper sprockets [E].
NOTE: There are shim washers by the sprockets. Note their position and quantity for installation.

Installation

1. Reverse the removal procedure

3.4.19 STOP GATE

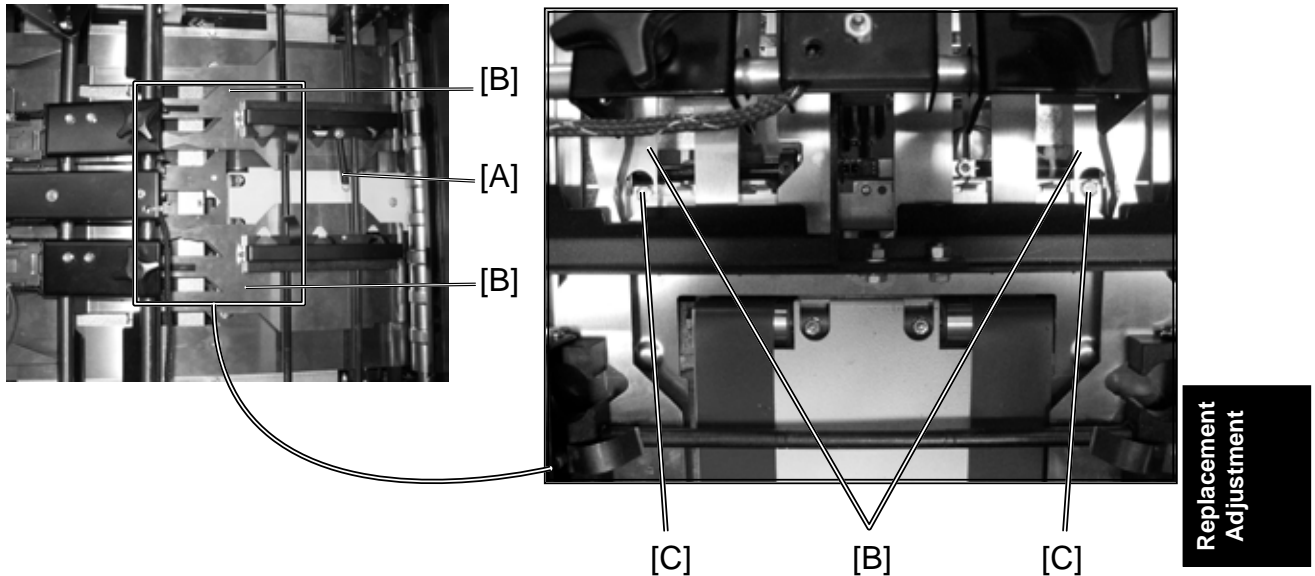

It is most important that the stop gate is parallel to the clinchers.

1. Set the machine to A3 or 11"x17".
2. Install interlock cheater.
3. Enter service mode, solenoids and activate SOL4.
4. Unhook the spring [A] and move both paper guides [B] 15 mm apart ( x1).
5. Enter service mode, motors.
6. Run M6 Cycle1 or Cycle2 so the two screws [C] become visible through the paper path.
7. Insert two sheets of A3 or 11"x17" paper in the stapling area.
8. Ensure that the sheets are perfectly aligned to the stop gate.
9. Run M5 Cycle1 to get two staples into the sheets.
10. Remove the sheets and measure the distance from the staple to the lead edge of the sheets.
11. If the difference is more than 0.3 mm the stop gate must be adjusted.

Adjustment

1. Loosen the two screws [C] and turn the stop gate slightly and tight the screws ( x2).
2. Repeat step 7 to 10.

CAUTION

Move back the side guides back to centre position and secure with the spring.

3.4.20 FOLD STOP

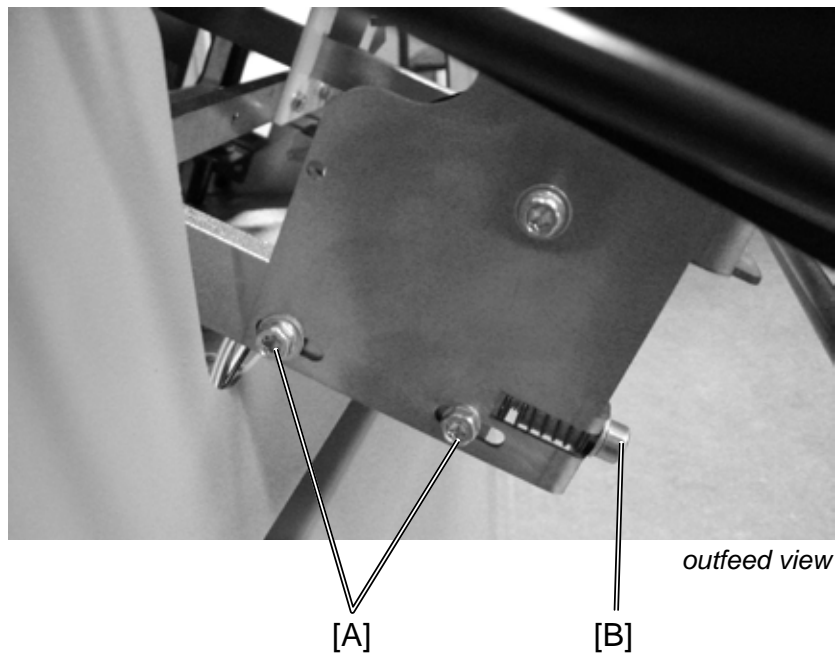

It is most important that the fold stop is parallel and have the right distance to the clinchers.

1. Remove trimmer unit if any (1.4.4).
2. Ensure that all teeth are in line at the fold stop. Check with a scale or similar.
3. Set the machine to A3 or 11"x17".
4. Check that following settings is set to 0,0 mm.

Staple On Fold: 0,0mm

Staple Fold Pos: 0,0mm

5. Hand feed two sheets into the machine and check the book.
6. If the book is skewed the fold stop must be adjusted.
7. Loosen the four screws [A], two on each side ($\times 4$).
8. Adjust with the two adjusting screws [B] ($\times 2$).
9. Repeat the adjustment until the book is not skewed.
10. Check that the staples are centred right over the fold line.
11. If not both screws [B] must be adjusted equal.
12. Tighten the screws [A].

Continued on next page....

3.4.20 FOLD STOP, CONTINUES

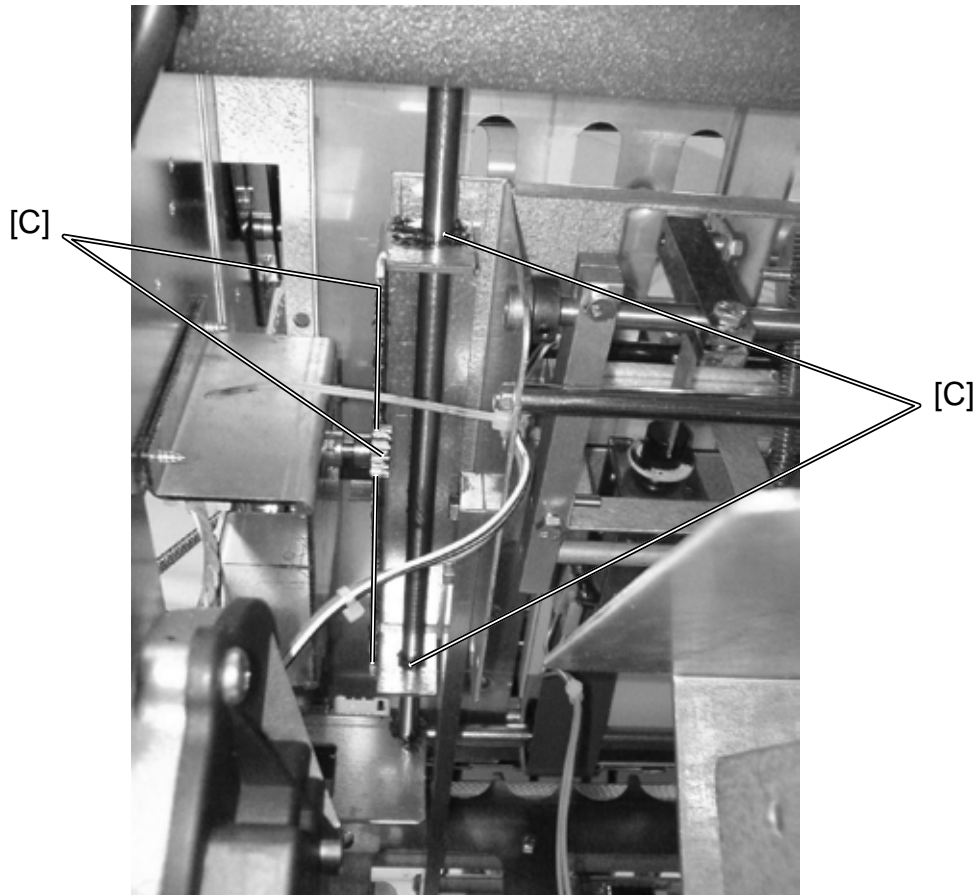

Replacement
Adjustment

*view through
outfeed cover*



Maintenance

1. Remove Outfeed cover (( 3.3.4).
2. Apply grease as illustrated [C].

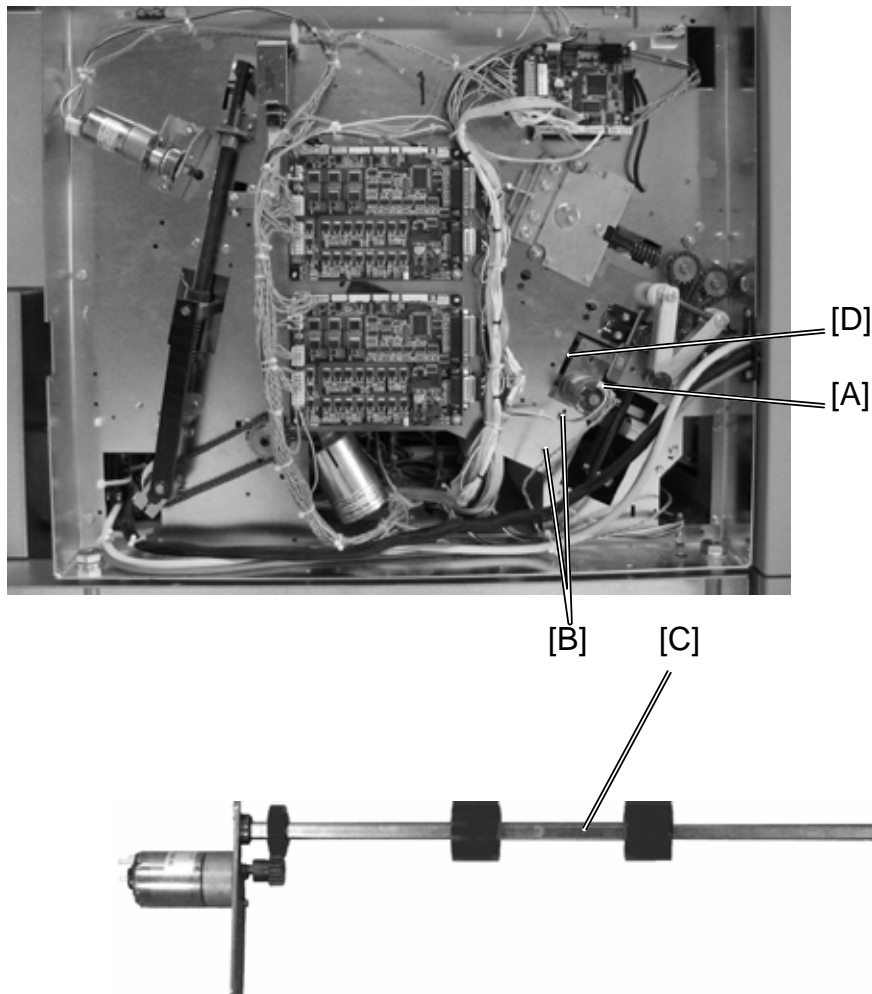
3.4.21 PRE-FOLD TRANSPORT BELTS



Removal

1. Remove Front and Rear cover ( 3.3.1, 3.3.2).
2. Remove connector [A] ( x1).
3. Remove four nuts, two on each side [B] ( x4).
4. Lift out the shaft [C].
5. Replace the belts.

Installation

1. Insert a screwdriver between the frame and the bearing brackets [D] to stretch the belts.

3.5 SENSORS AND SWITCHES

3.5.1 Q1 INFEEED PAPER PATH



Replacement
Adjustment

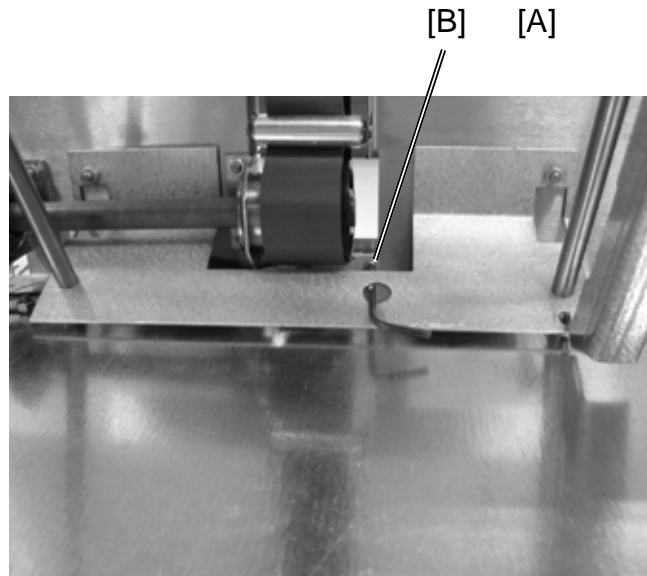

Removal

1. Remove in-feed module (refer to 3.4.1).
2. Loosen the rack by removing one screw [A], which is holding the rack in place and pull up the back jogger assy.
3. Put the rack back in place and mount the screw [A] (1 x1).
4. Remove allen screw [B] for the sensor.



Installation

1. Reverse the removal procedure

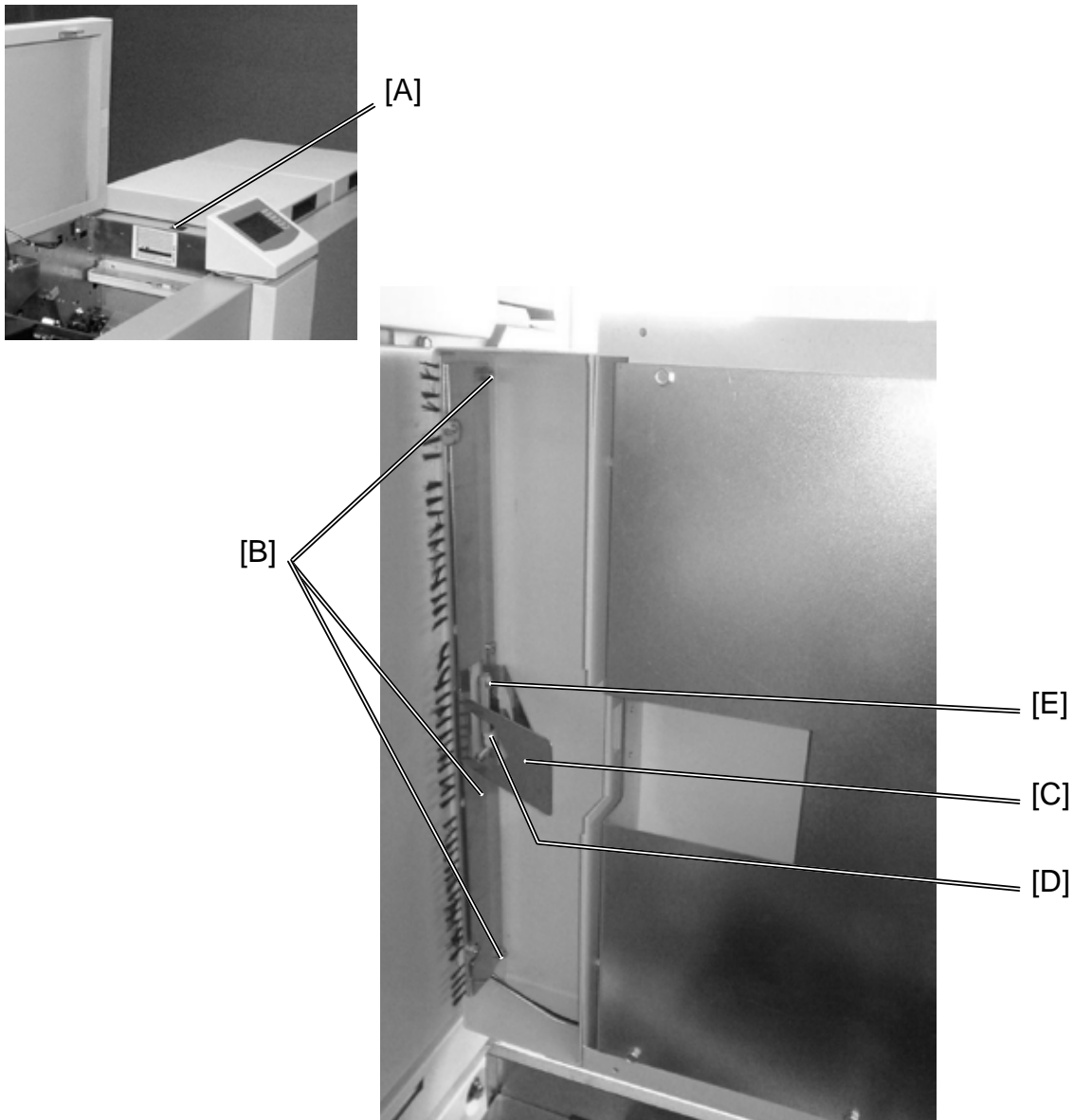
3.5.2 Q2 MANUAL FEEDING START SENSOR



Removal

1. Open the top cover.
2. Switch off the main power switch [A].
2. Loosen the nuts [B] ( x3).
3. Slide out the paper guide [C].
2. Disconnect the connector [D] ( x1).
3. Remove screw [E] and remove the sensor ( x1).

Installation

1. Ensure that the wires will dressed above the anti static brush.

3.5.3 Q3 INFEED MOTOR ENCODER (M1)

Sensor Q3 is an integrated part of the Infeed motor and can not be replaced separately. Replace Infeed motor ( 3.6.1).

Replacement
Adjustment

3.5.4 Q4 BACK JOGGER MOTOR HOME SWITCH (M2)

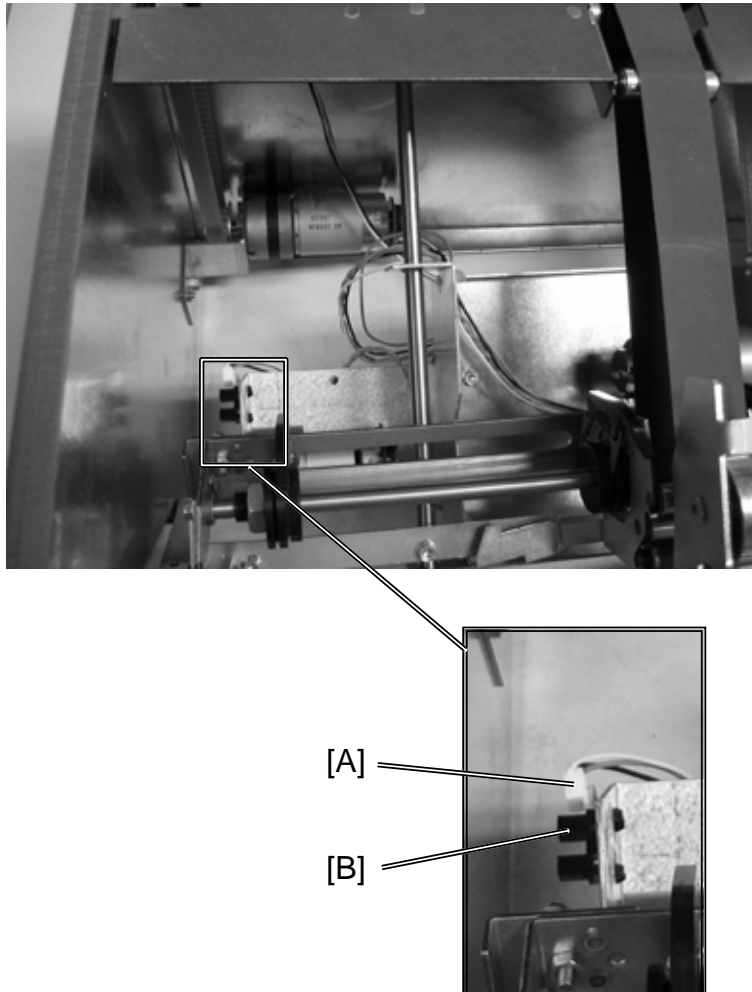

Removal

1. Open top cover.
2. Install interlock cheater.
3. Enter service mode. "Motors".
4. Enter M3.
5. Run M3 down to end position and stop the motor.
6. Disconnect connector [A] and remove sensor [B] ( x1).

Installation

1. Reverse the removal procedure

3.5.5 Q5 BACK JOGGER POSITIONING MOTOR ENCODER (M3)

Sensor Q5 is an integrated part of the Back jogger positioning motor and can not be replaced separately. Replace Back jogger positioning motor ( 3.6.3).

Replacement
Adjustment

3.5.6 Q6 SIDE JOGGER MOTOR ENCODER (M4)

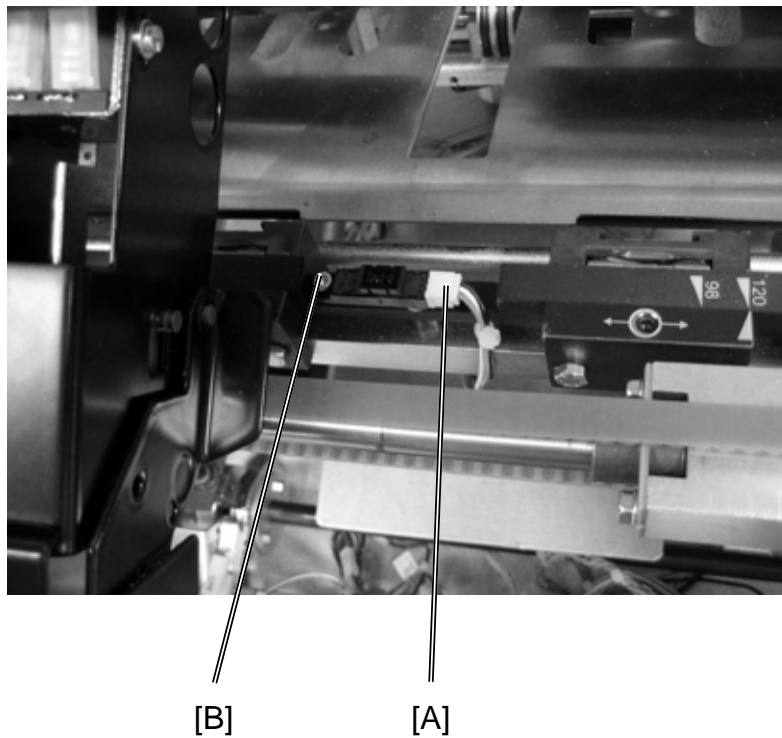

Sensor Q6 is an integrated part of the Side jogger motor and can not be replaced separately. Replace Side jogger motor ( 3.6.4).

3.5.7 Q7 EDGE STAPLING START CYCLE SENSOR



Replacement
Adjustment

Removal

1. Remove In-feed idler arm assembly (( 3.4.4).
2. Remove connector [A] ( x1).
3. Remove allen screw [B] for sensor.



Installation

1. Reverse the removal procedure

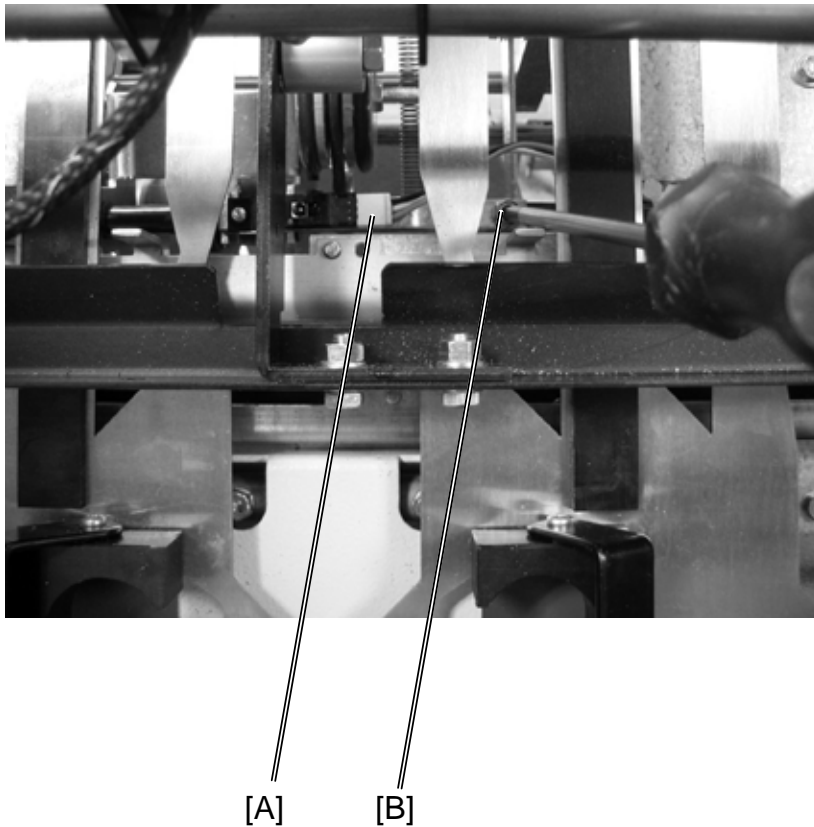
3.5.8 Q8 SIDE STAPLING START CYCLE SENSOR



Removal

1. Remove the paper path ( 3.3.6).
2. Disconnect the connector [A] ( x1).
3. Remove screw [B] and remove the sensor with bracket ( x1).

Installation

1. Reverse the removal procedure

3.5.9 Q9 STAPLE/FOLD POSITIONING MOTOR ENCODER (M6)

Sensor Q9 is an integrated part of the Staple/Fold positioning motor and can not be replaced separately. Replace Staple/Fold positioning motor ( 3.6.6).

Replacement
Adjustment

3.5.10 Q10 PRE-FOLD TRANSPORT MOTOR ENCODER (M8)

Sensor Q10 is an integrated part of the Pre-fold transport motor and can not be replaced separately. Replace Pre-fold transport motor ( 3.6.8).



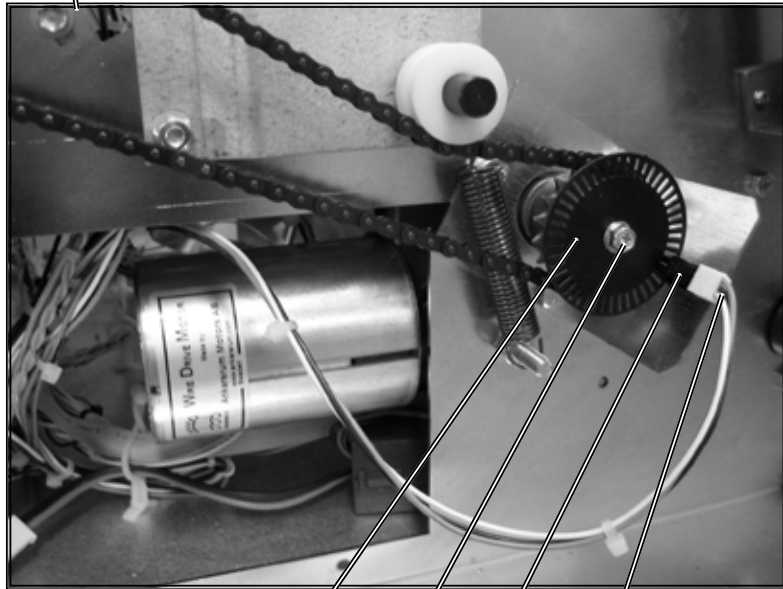
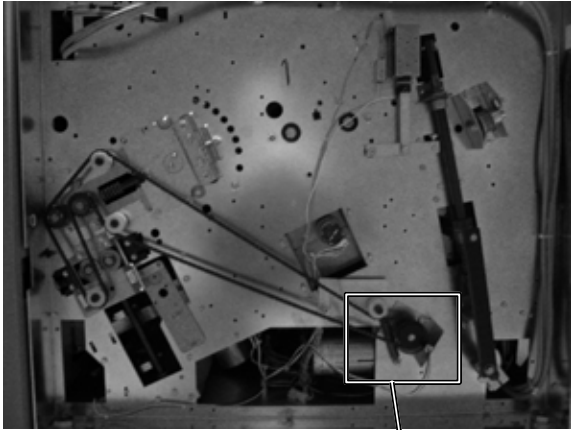

3.5.11 Q11 FOLD ROLLER MOTOR ENCODER (M9)



[B] [A] [D] [C]

Replacement
Adjustment

Removal

1. Remove the Left cover (Front cover ( 3.3.1) or Rear cover ( 3.3.2) depending on model).
2. Remove the screw [A] and remove the Tacho disc [B] ( x1).
3. Disconnect the connector [C] ( x1).
4. Remove the sensor [D].



Installation

1. Reverse the removal procedure

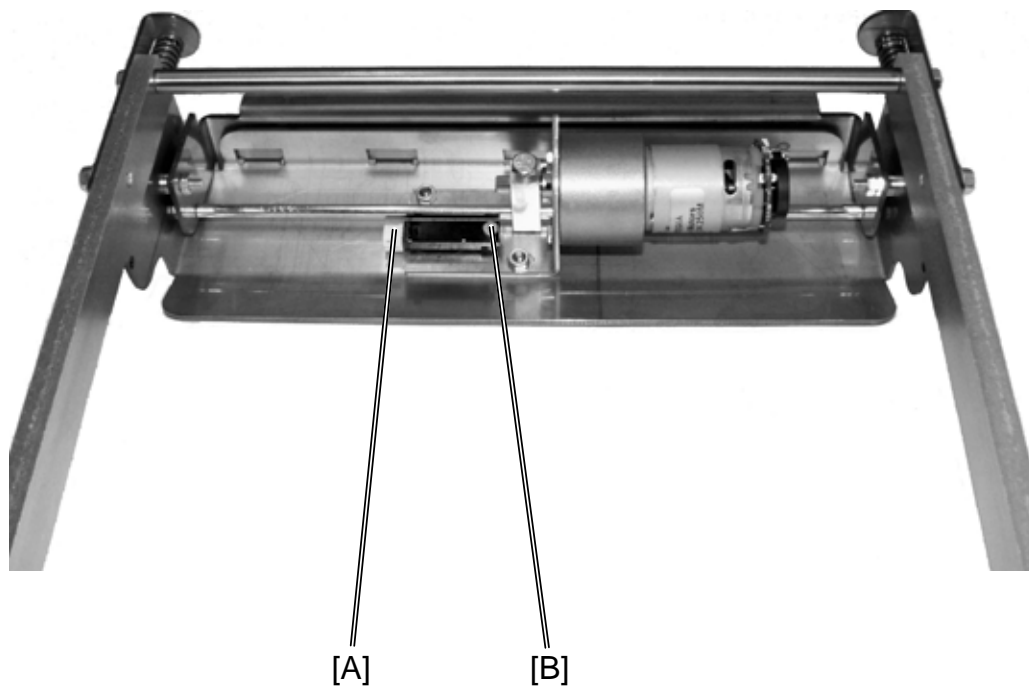
3.5.12 Q12 FOLD SENSOR



Removal

1. Enter A3 or 11"x17".
2. Remove connector [A] ( x1).
3. Remove screw [B] and remove the sensor ( x1).

Installation

1. Reverse the removal procedure

3.5.13 Q13 FOLD STOP POSITIONING MOTOR ENCODER (M11)



Sensor Q13 is an integrated part of the Fold stop positioning motor and can not be replaced separately. Replace Fold stop positioning motor ( 3.6.11).

Replacement
Adjustment

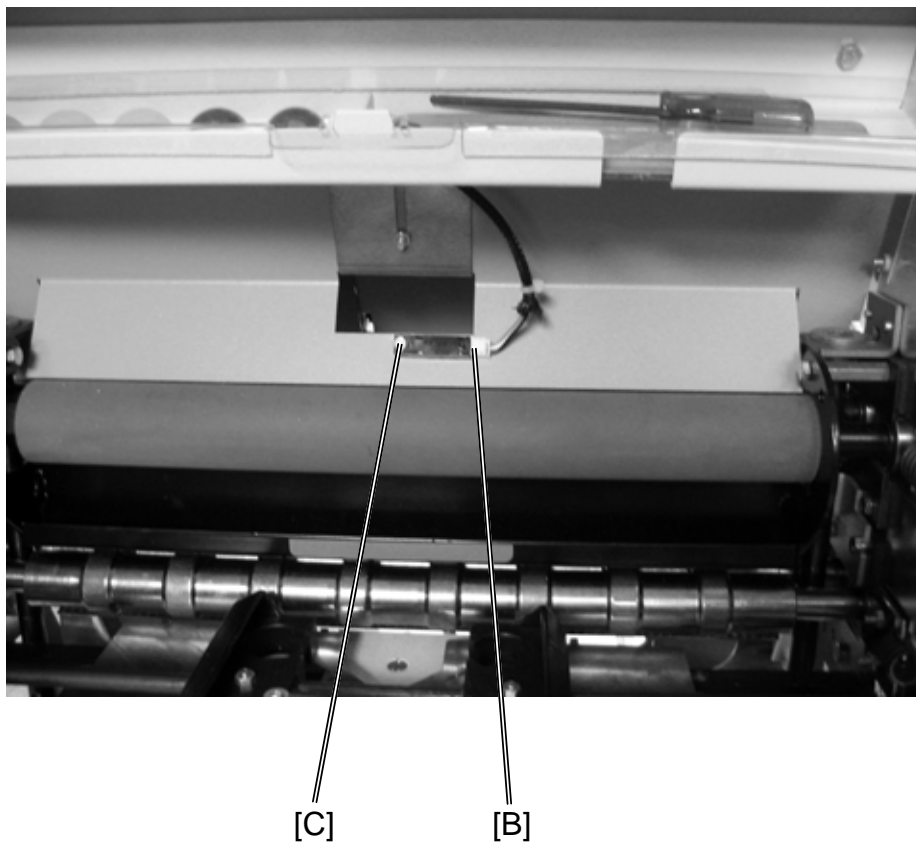
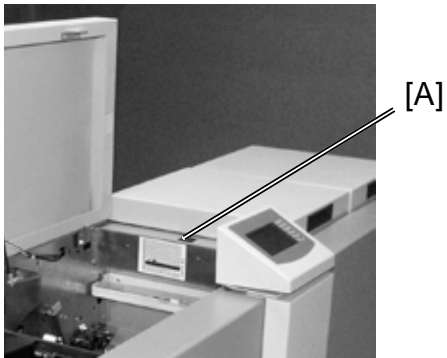
3.5.14 Q14 EXIT SENSOR



Removal

1. Open the top cover.
2. Switch off the main power switch [A].
3. Disconnect connector [B] ( x1).
4. Remove screw [C] ( x1).

Installation



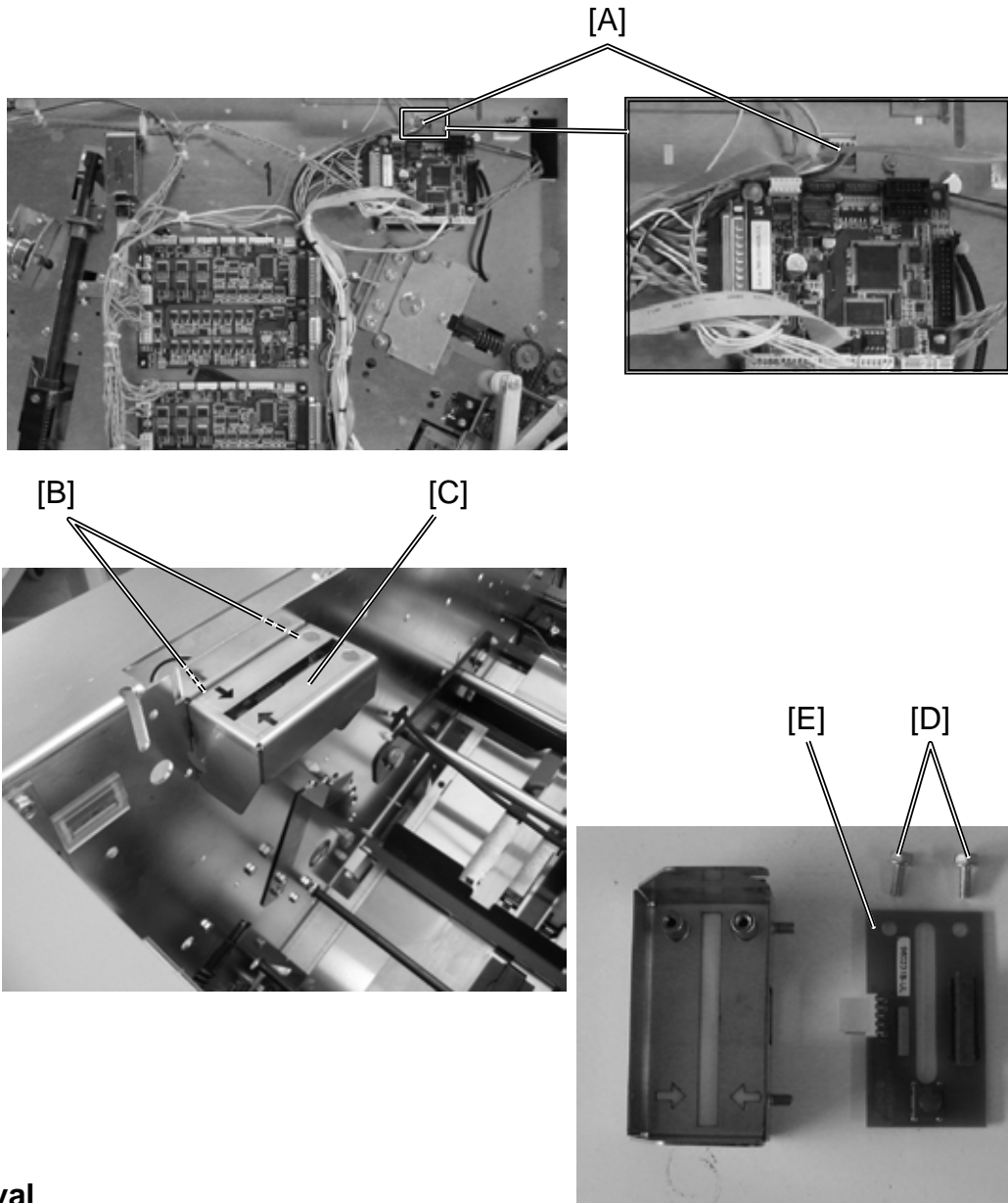

1. Reverse the removal procedure

3.5.15 Q15 COVER OPEN SENSOR



Replacement
Adjustment

Removal

1. Remove the Right cover (Front cover ( 3.3.1) or Rear cover ( 3.3.2) depending on model).
2. Disconnect connector [A] ( x1).
3. Remove the two nuts [B] and remove the interlock box [C] ( x2).
4. Remove the two screws [D] and remove the printed circuit board [E] ( x2).

Installation

1. Reverse the removal procedure

3.5.16 SW1 BACK JOGGER MOTOR (M11) HOME POS. SWITCH

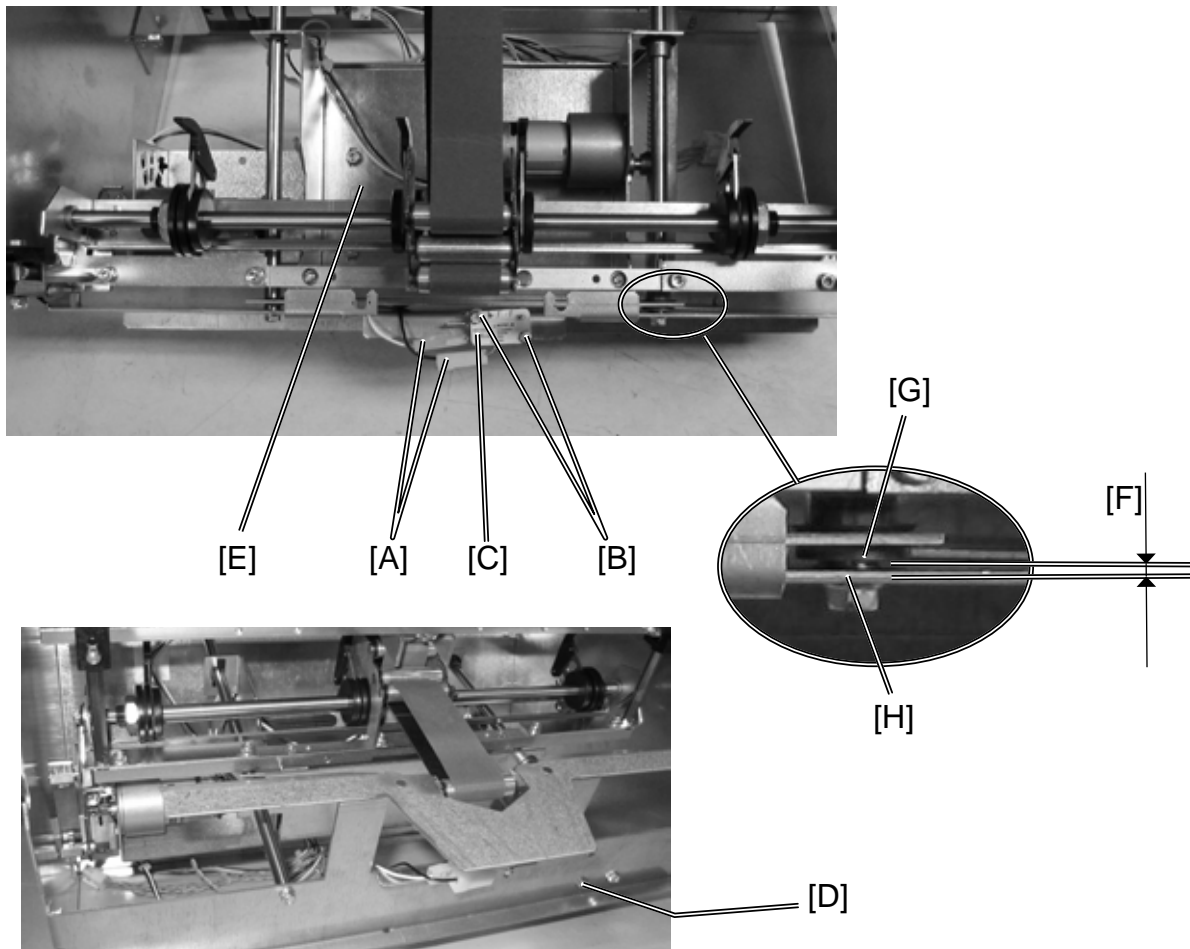

Removal

1. Remove in-feed unit ((👉 3.4.1).
2. Disconnect the connectors [A] (📧 x1).
3. Remove the screws [B] and remove the micro switch [C] (🛠️ x2).

Installation

1. Reverse the removal procedure

Adjustment

1. Loosening the rack by removing screw [D], which is holding the rack in place so the jogger assembly [E] can be moved towards the switch.
2. Adjust the switch so it clicks when the distance [F], between bushing in the jogger assembly [G] and the bracket [H], is 0,5 – 1 mm.
3. Put the rack back in place and mount the screw.

3.5.17 SW2 STAPLER MOTOR (M5) HOME POS. SWITCH

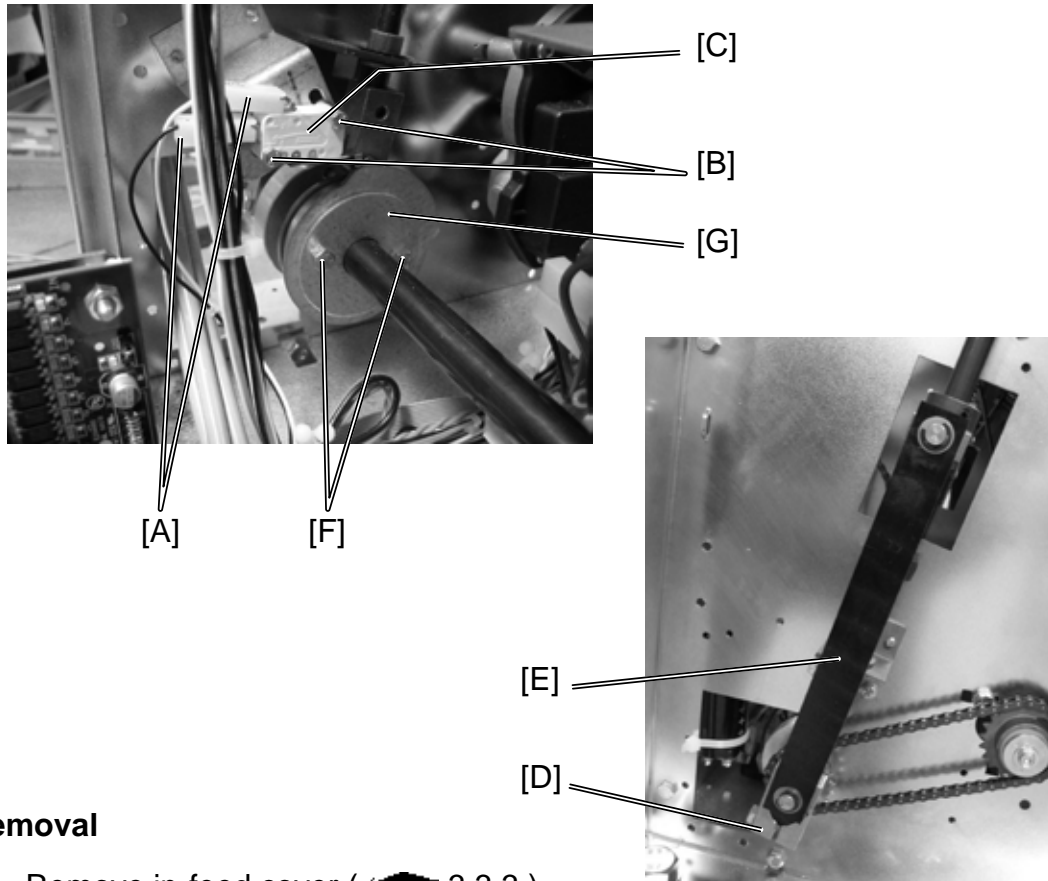

Replacement
Adjustment

Removal

1. Remove in-feed cover (3.3.3).
2. Disconnect the connectors [A] (x1).
3. Remove the screws [B] and remove the switch [C] (x2).

Installation

1. Reverse the removal procedure

Adjustment, switch position

1. Switch arm should be placed in the middle position of the switch.
2. Adjust the switch until it is fully actuated but not bottomed out.

Adjustment, home position

1. In home position the crank arm [D] should be parallel to the connecting rod [E].
2. Adjust the position by loosening the 2 screws [F] and turn the home position cam [G].

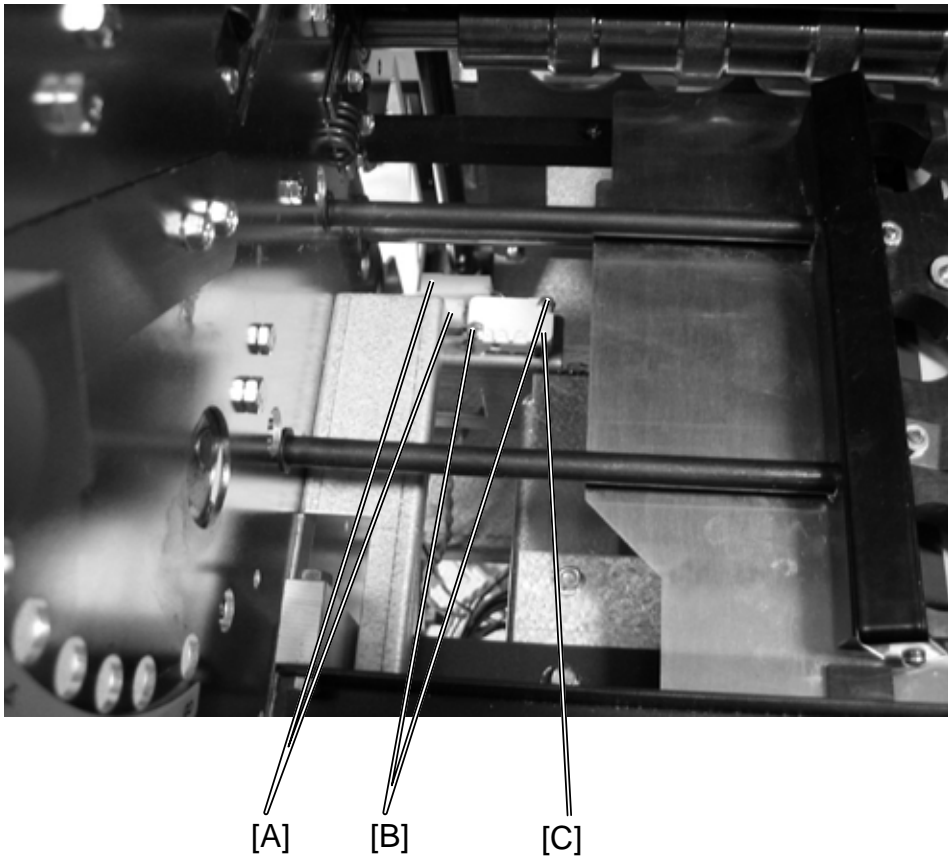
3.5.18 SW4 STAPLE/FOLD POS. MOTOR (M6) HOME POS. SWITCH**Removal**

1. Remove paper path ((👉 3.3.6).
2. Disconnect the connectors [A] (📎 x1).
3. Remove the screws [B] and remove the switch [C] (🔧 x2).

Installation



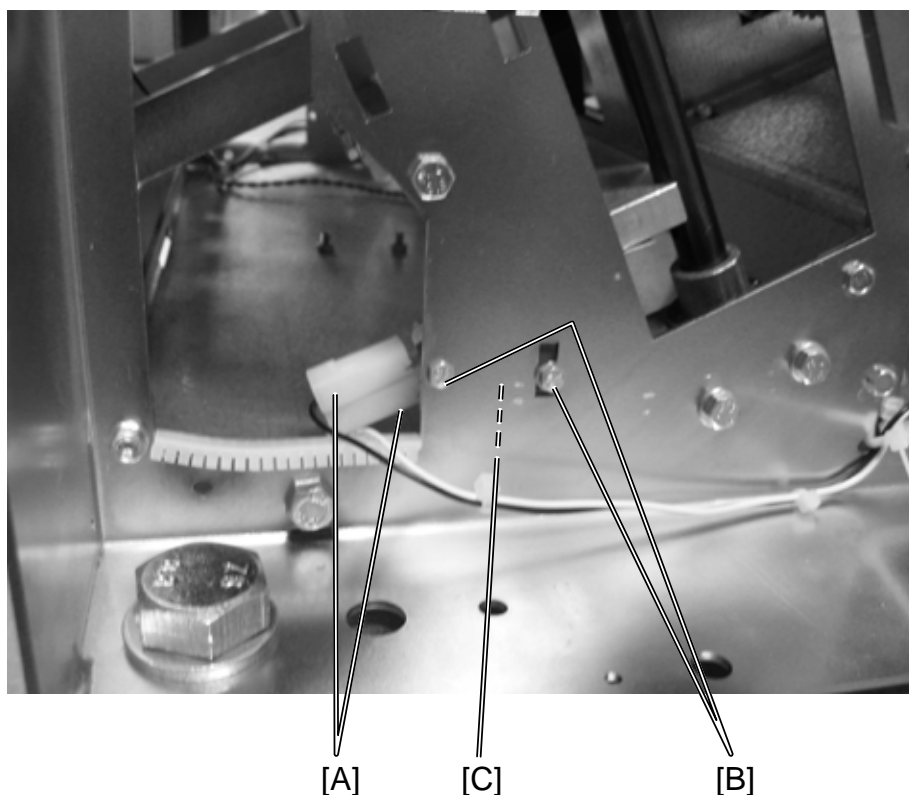

1. Reverse the removal procedure

3.5.19 SW5 FOLD KNIFE MOTOR (M10) HOME POS. SWITCH



Replacement
Adjustment

Removal

1. Switch off the main power switch.
2. Remove the Left cover (Front cover ( 3.3.1) or Rear cover ( 3.3.2) depending on model).
3. Disconnect the connectors [A] ( x1).
4. Remove the screws [B] and remove the switch [C] ( x2).

Installation



1. Reverse the removal procedure

Adjustment

1. Switch actuator should be placed in the middle position of the switch.
2. With the knife in position (against mechanical stop), there should be 0,5-1,5mm play between switch arm and knife beam when switch arm is bottomed out.

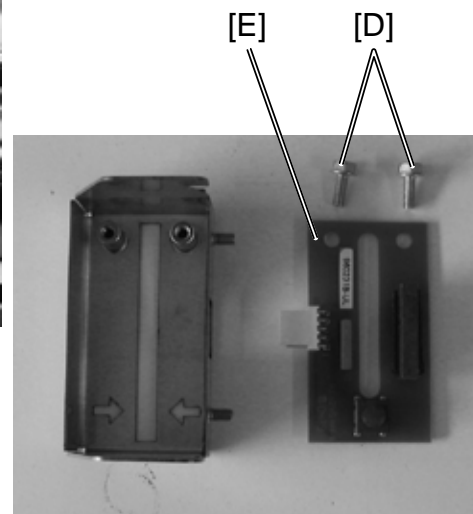
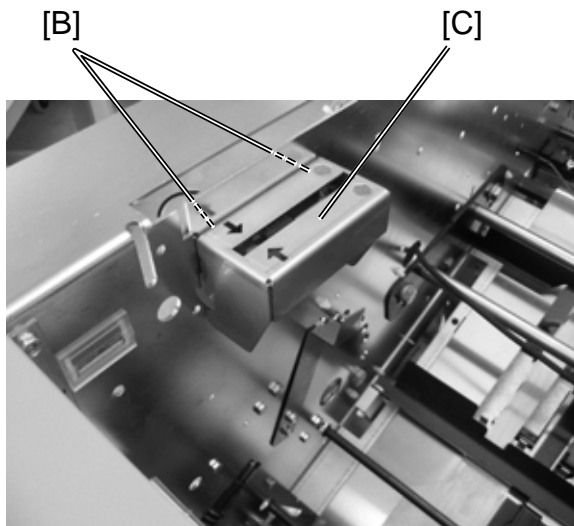
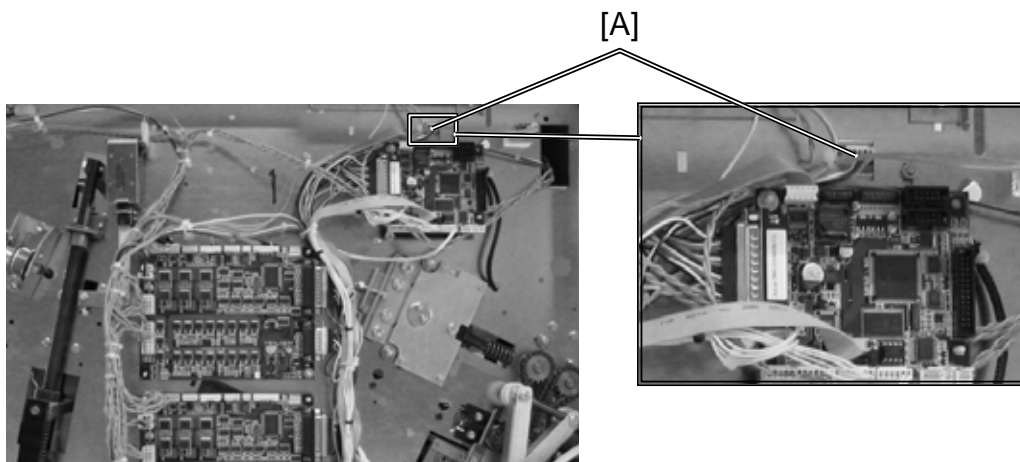
NOTE: The knife cam is follower is normally outside cam in home position which allows performing the adjustment.

3.5.20 SW6 INTERLOCK CIRCUIT**Removal**

1. Remove the Right cover (Front cover ( 3.3.1) or Rear cover ( 3.3.2) depending on model).
2. Remove connector [A]
3. Remove the two nuts [B] and remove the interlock box [C].
4. Remove the two screws [D] and remove the printed circuit board [E].

Installation



1. Reverse the removal procedure

3.6 MOTORS

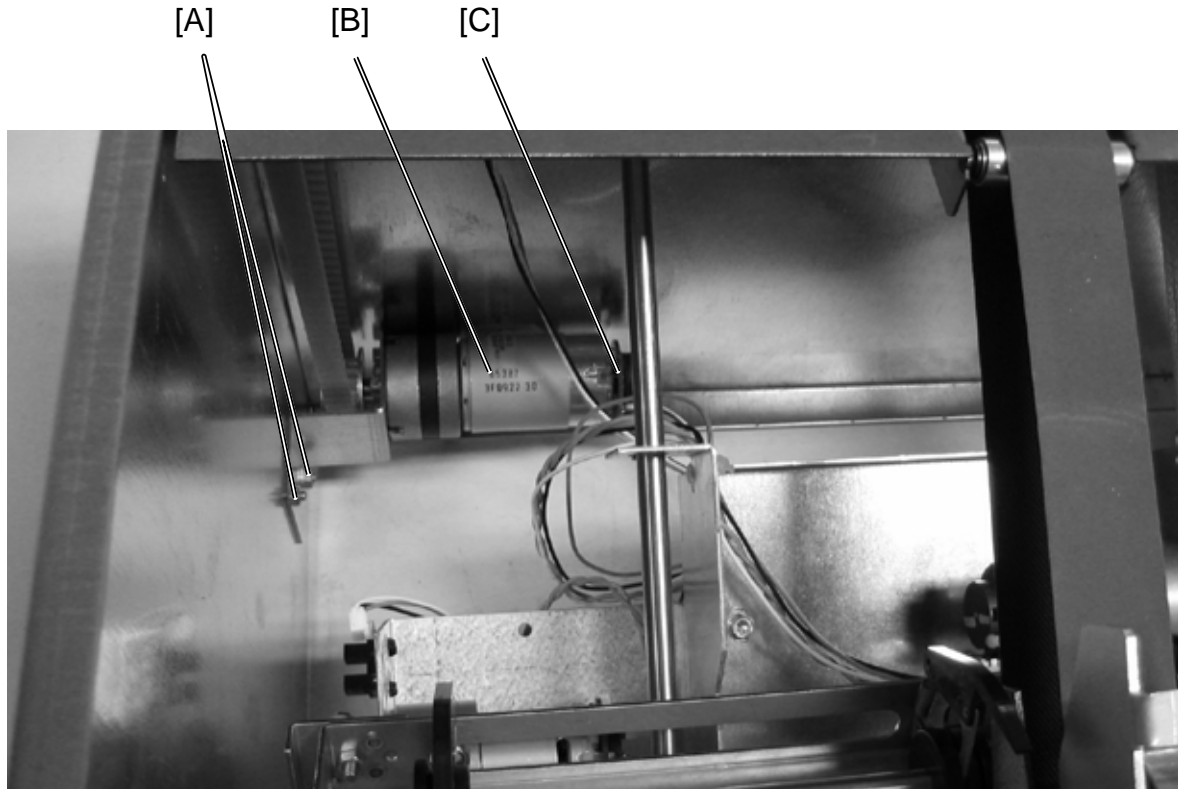
3.6.1 INFEEED MOTOR M1



Removal

1. Open top cover.
2. Install interlock cheater.
3. Enter service mode. "Motors".
4. Enter M3.
5. Run M3 down to end position and stop the motor.
6. Remove cheater.
7. Move side jogger channels to center position.
8. Remove the nuts [A] and remove motor [B] and bracket ( x2).
9. Disconnect the connectors [C] ( x2).
10. Separate motor from bracket.

Installation

1. Reverse the removal procedure.



3.6.2 BACK JOGGER MOTOR M2



[A]

[B]

Removal

1. Open top cover.
2. Install interlock cheater.
3. Enter service mode. "Motors".
4. Enter M3.
5. Run M3 down to end position and stop the motor.
6. Snap out the link [A] between the motor and the jogger assembly at the jogger assembly side.
7. Note the position in the slot and remove the screws [B] ( x2).
8. Remove the connectors and lift out the motor bracket ( x2).

Installation

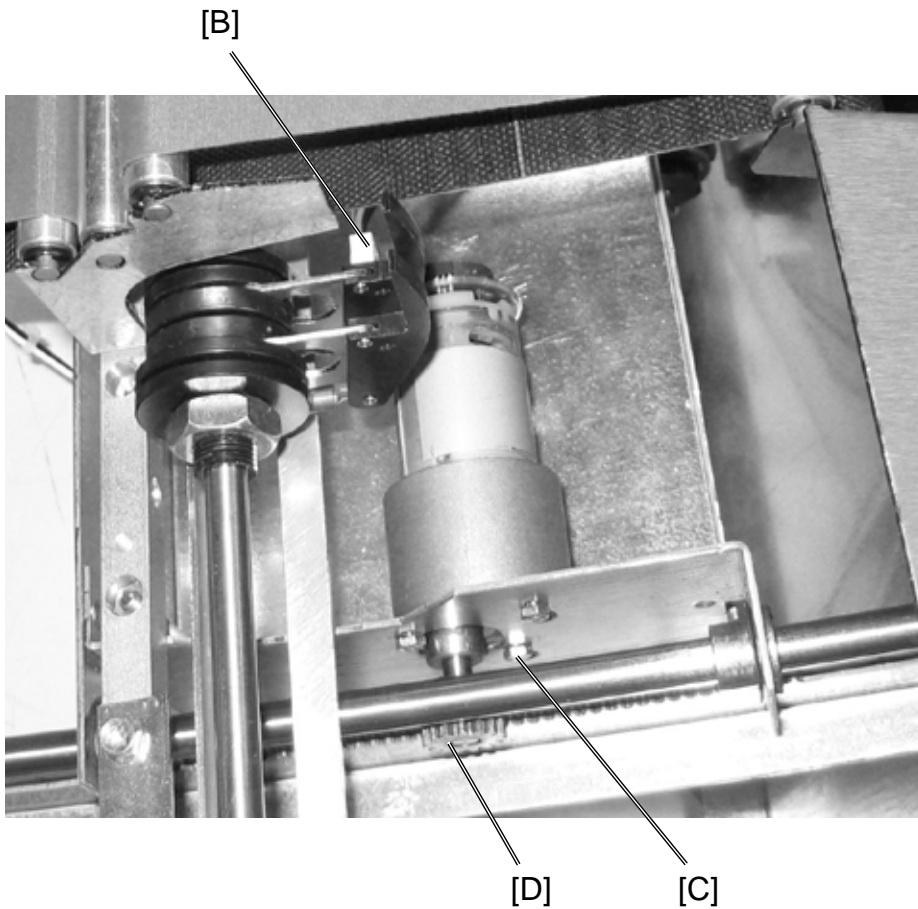
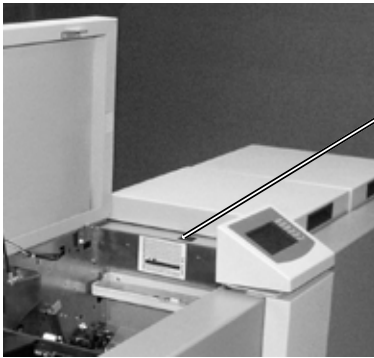

1. Reverse the removal procedure.
2. Mount the bracket at same location as before.
3. Snap in link correctly at ball bearing.

3.6.3 BACK JOGGER POSITIONING MOTOR M3



Replacement
Adjustment

Removal

1. Open the top cover.
2. Switch off the main power switch [A].
3. Disconnect the connectors [B] ( x2).
4. Remove the screws [C] ( x3).
5. Loosen allen screw and remove gear [D] from motor shaft ( x1).

Installaion

1. Reverse the removal procedure.

3.6.4 SIDE JOGGER MOTOR M4

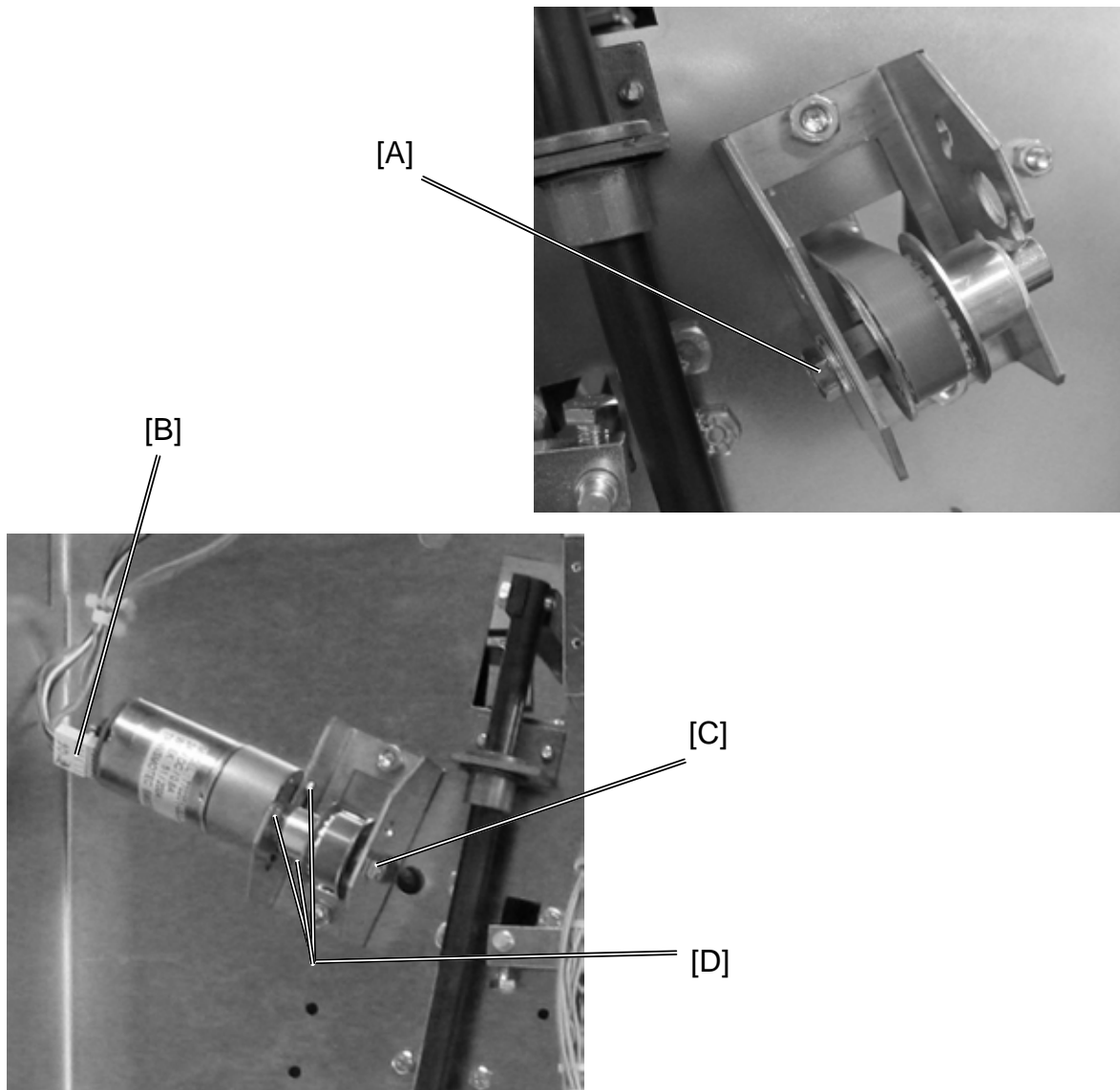

Removal

1. Remove Front and Rear cover ((🔧 3.3.1, 3.3.2).
2. Loosen screw on opposite side of machine and loosen tension of belt [A].
3. Disconnect the connectors [B] (📏 x2).
4. Loosen support screw [C] (🔧 x1).
5. Loosen allen screw on pulley (🗜️ x1).
6. Loosen screws [D] and remove motor from keyholes (🔧 x3).

Installation



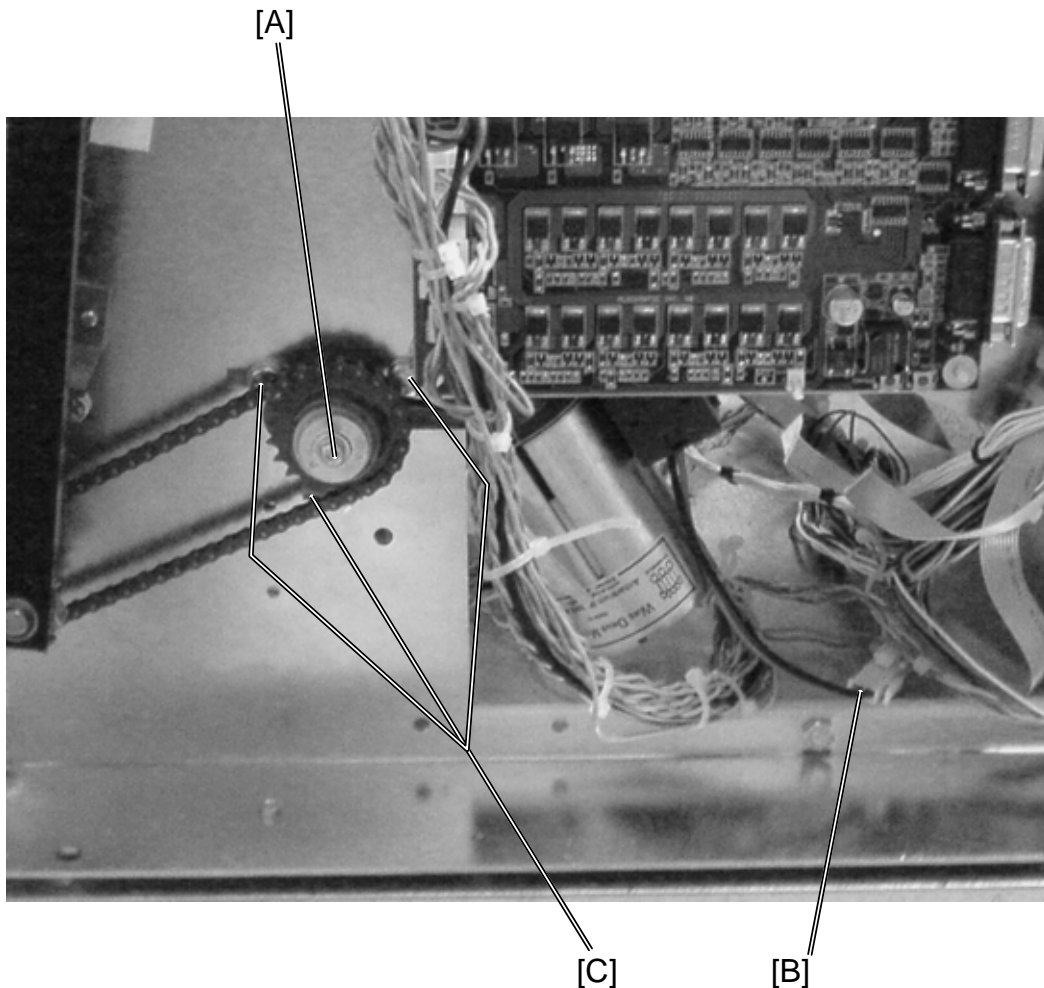

1. Reverse the removal procedure.

3.6.5 STAPLER MOTOR M5



Replacement
Adjustment

Removal

1. Remove the Right cover (Front cover ( 3.3.1) or Rear cover ( 3.3.2) depending on model).
2. Remove screw [A] ( x1).
3. Disconnect connector [B] ( x2).
3. Remove the screws [C] and remove motor ( x3).

Installation

1. Reverse the removal procedure.

3.6.6 STAPLE / FOLD POSITIONING MOTOR M6

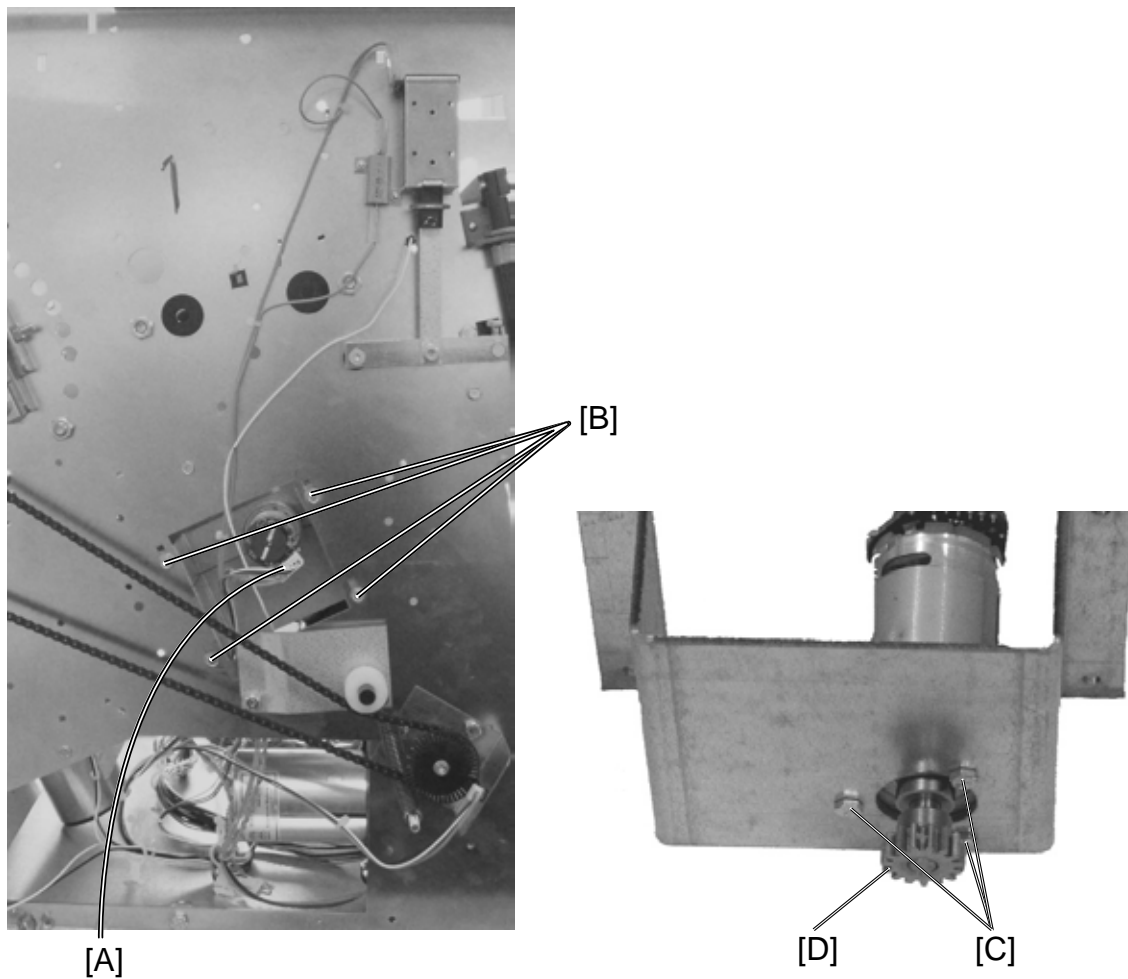

Removal

1. Remove infeed module ((👉 3.4.1).
2. Disconnect connectors [A] (📡 x2).
3. Remove screws [B] (🔩 x4).
NOTE: Registration carriage will move down towards fold area when loosen all screws.
4. Lift out motor bracket.
5. Remove screws [C] (🔩 x3).
6. Loosen allen screw and remove gear [D] from motor shaft (🌀 x1).

Installation

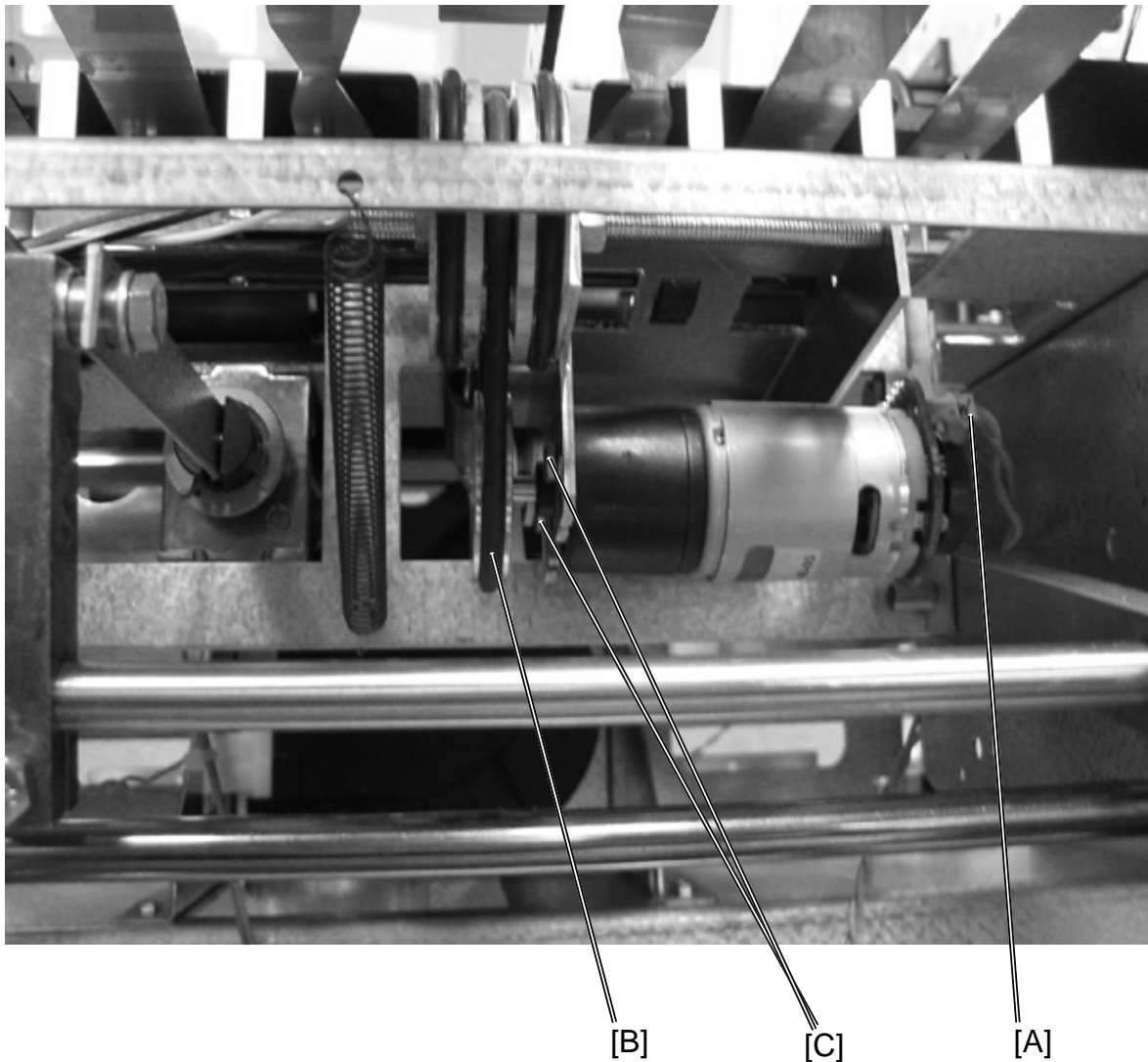

1. Reverse the removal procedure.

3.6.7 STAPLED SET TRANSPORT MOTOR M7



Replacement
Adjustment

Removal

1. Remove infeed module ( 3.4.1).
2. Disconnect connector [A] ( x1).
3. Hook off o-ring [B].
4. Loosen screws and lift out motor [C] ( x2).

Installation

1. Reverse the removal procedure.





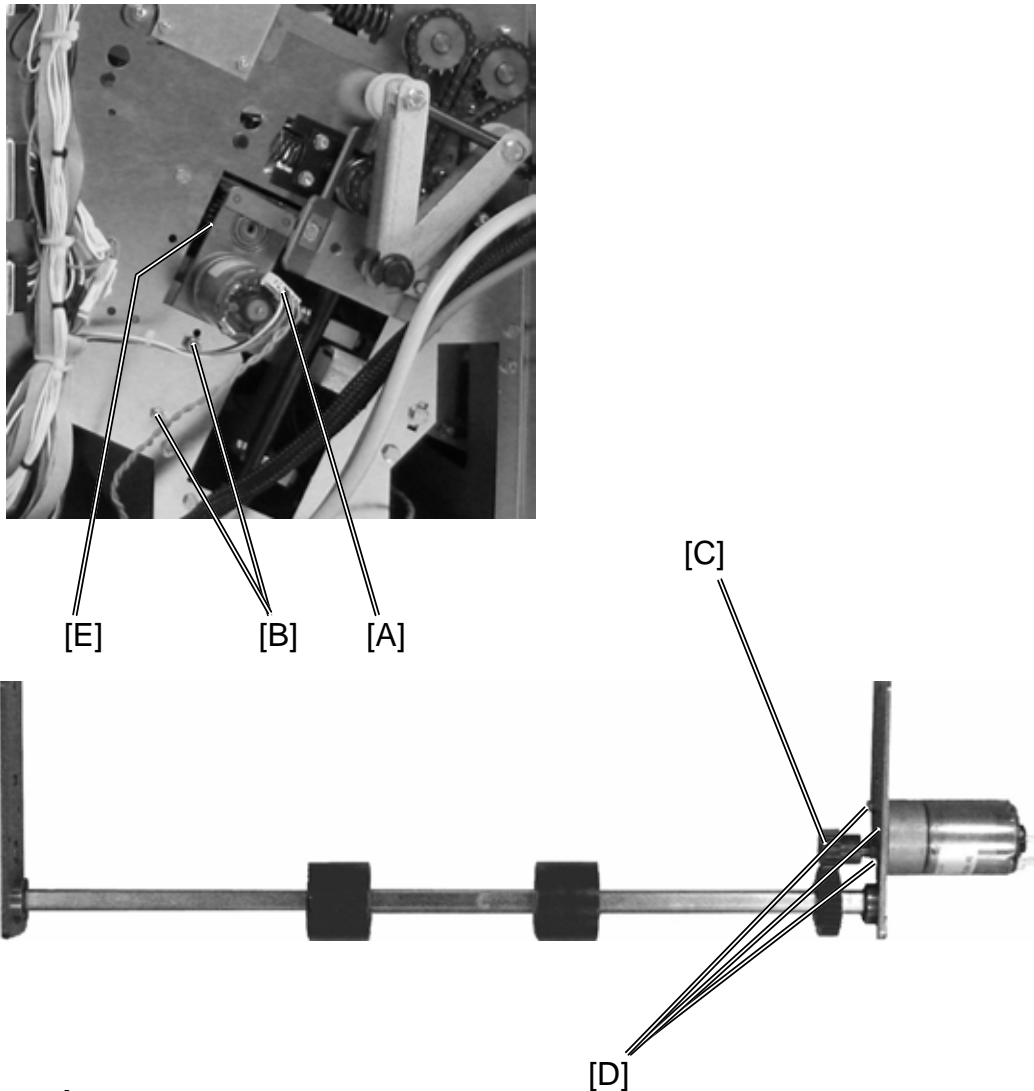

CAUTION

Replace the o-ring if slightest evidence of wear or loss of friction. The o-ring is a wear out part.

3.6.8 PRE-FOLD TRANSPORT MOTOR M8



Removal

1. Remove the Right cover (Front cover ( 3.3.1) or Rear cover ( 3.3.2) depending on model).
2. Disconnect connectors [A] ( x2).
3. Remove the nuts [B], two on each side ( x2).
4. Lift out drive roller assy together with motor.
5. Loosen allen screw and remove gear [C] from motor shaft ( x1).
6. Remove screws [D] ( x3).

Installation



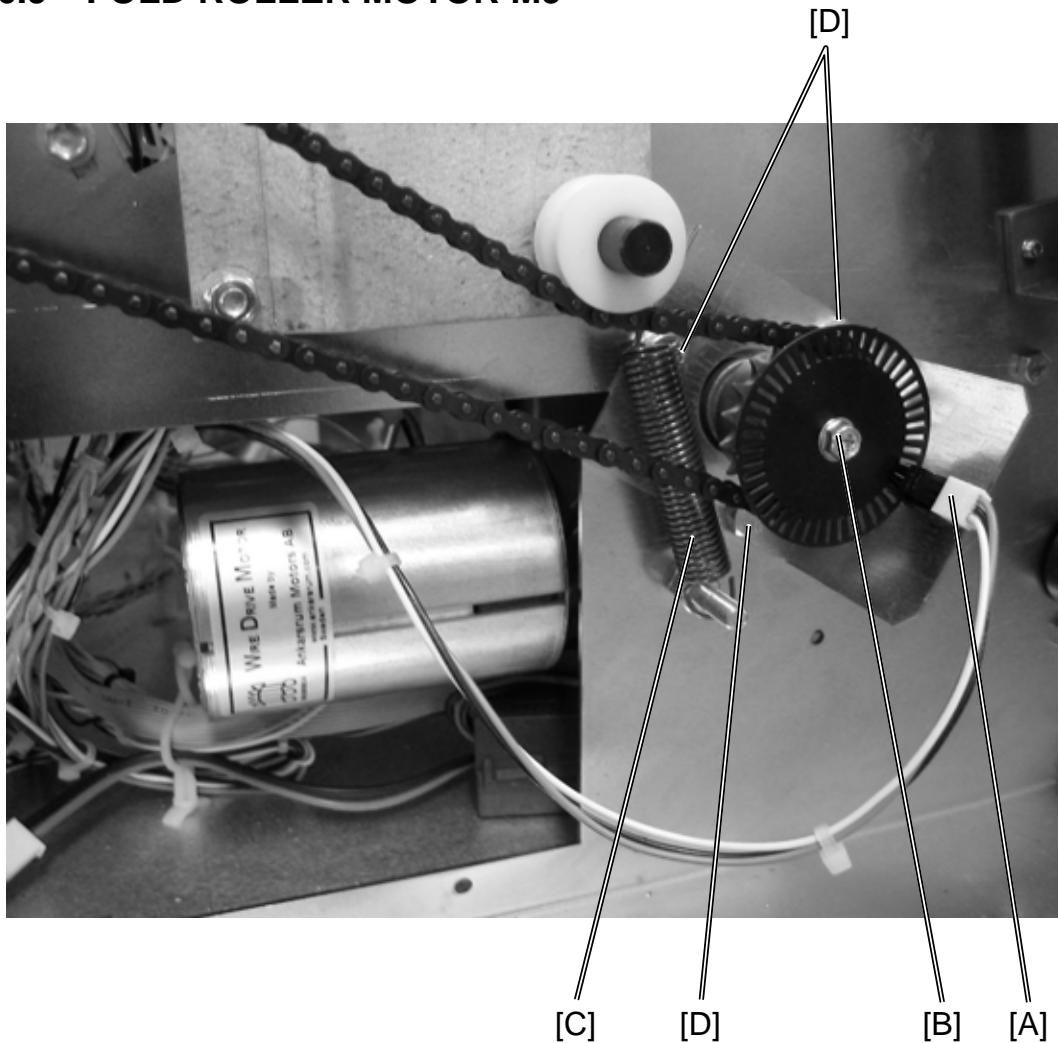

1. Reverse the removal procedure.
2. Use a screwdriver between shaft and side frame [E] to tension the belt.

3.6.9 FOLD ROLLER MOTOR M9



Replacement
Adjustment

Removal

1. Remove the Left cover (Front cover ( 3.3.1) or Rear cover ( 3.3.2) depending on model).
2. Disconnect motor ( x2). Connector not visible in picture.
3. Disconnect connector [A] ( x1).
4. Remove screw [B] to remove tachometer disc.
5. Unhook spring [C].
6. Remove screws [D] ( x3).
7. Lift out motor.

Installation

1. Reverse the removal procedure.
2. Check that chain is tensioned by spring. Chain should not be slack.

3.6.10 FOLD KNIFE MOTOR M10

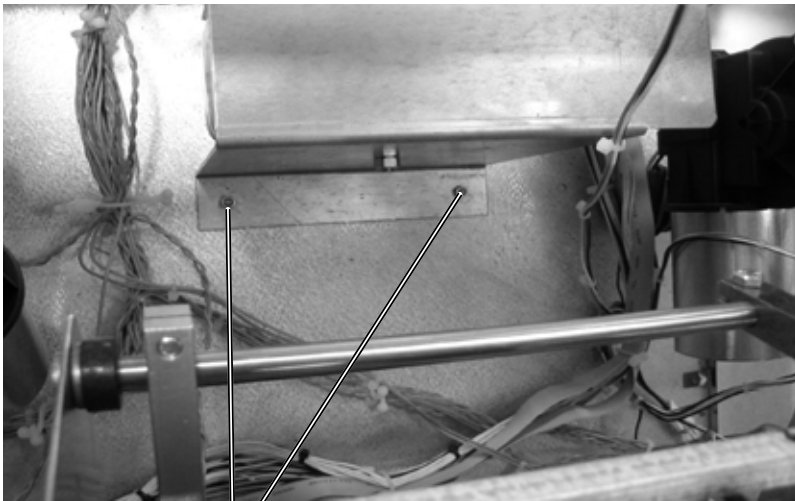

[B]

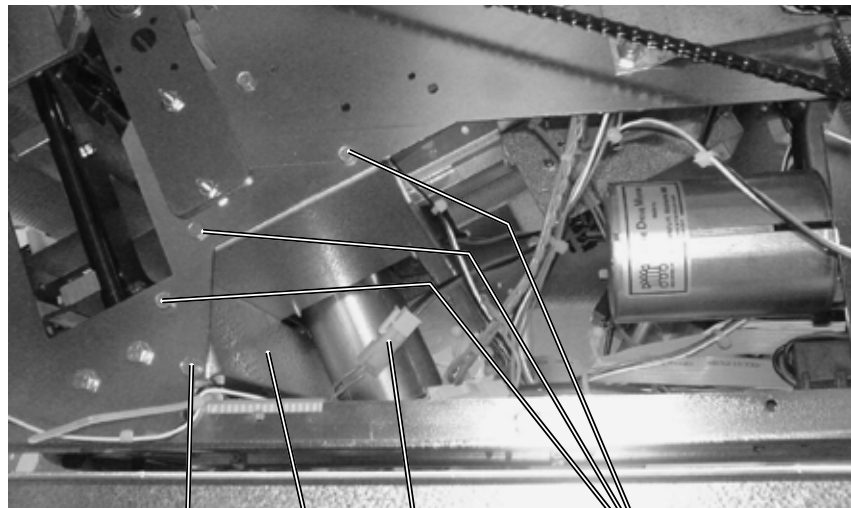

[E]

[D]

[A]

[C]

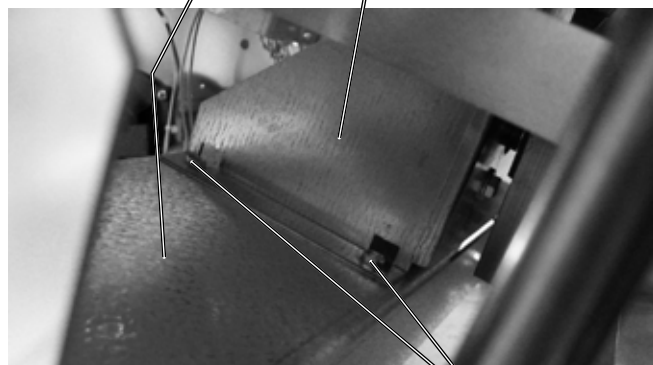







[G]

[F]

Continued on next page....

3.6.10 FOLD KNIFE MOTOR M10, CONTINUES

Removal

1. Enter A3 size (11x17").
2. Switch off main power and disconnect power cord.
3. Remove infeed cover ( 3.3.3).
4. Disconnect connector [A] ( x1).
5. Loosen nuts [B] holding transformer bracket ( x2).
6. Move transformer bracket so that Fold knife motor later can pass.
7. Remove three screws [C] on each side of the machine for the motor bracket support [D] ( x6).
8. Loosen one screw on each side of the machine [E] ( x2).
9. Tilt the motor bracket support downwards. Turn the plastic cam so it do not interfere.
10. Loosen two screws [F] on each side of bracket and slide out motor bracket [G] ( x4).
11. Remove cam from motor axle.
12. Remove motor from bracket.

Replacement
Adjustment



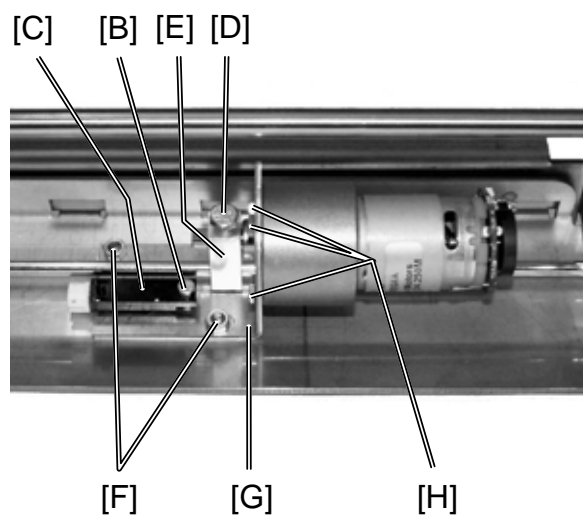
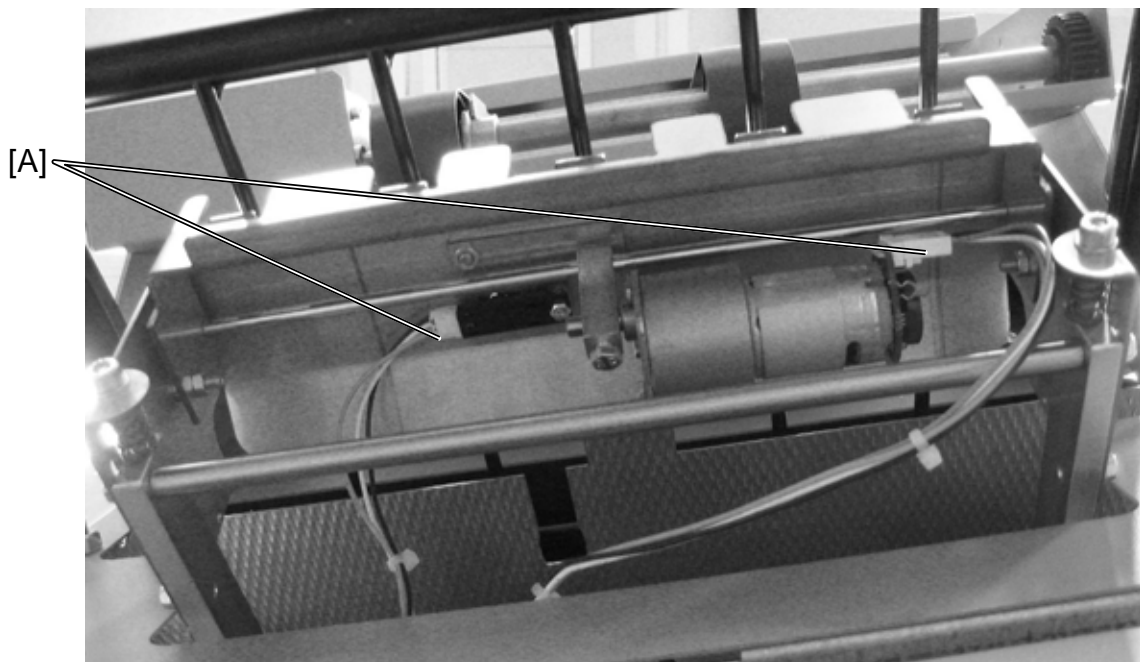

Installation

1. Reverse the removal procedure.
2. Remove retaining ring and Woodruff key from motor shaft.
3. Ensure cam follower located on fold knife, fits into the cam when turning.

3.6.11 FOLD STOP GATE MOTOR M11



Removal

1. Enter A3 size (11x17").
2. Disconnect connectors [A] ( x3).
3. Remove screw [B] and remove sensor [C] ( x1).
4. Loosen screw [D] and remove lever [E]
5. Remove nuts [F] and remove motor bracket [G] ( x2).
6. Remove screws [H] and remove motor from bracket ( x3).

Installation

1. Reverse the removal procedure.

3.6.12 BELT STACKER MOTOR ST-M1

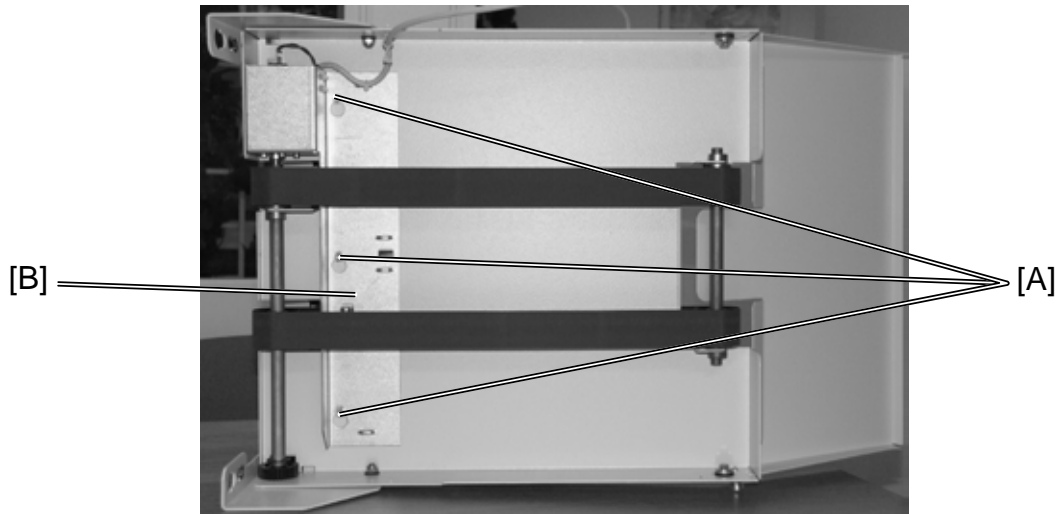

Replacement
Adjustment

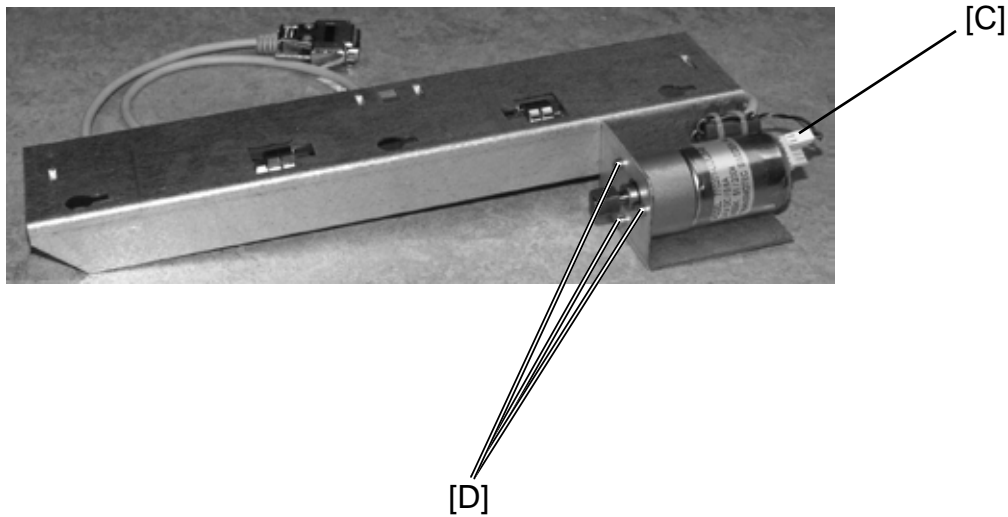

Removal

1. Loosen nuts [A] (🔧 x3).
2. Slide the motor bracket [B] and remove.
3. Disconnect connector [C] (🔌 x1).
4. Remove screws [D] (🔧 x3).

Installation

1. Reverse the removal procedure.
NOTE: Stacker motor pulley is D-shaped.

Page intentionally blank

3.7 SOLENOIDS

3.7.1 SOL1 EDGE STAPLING TRANSPORT SOLENOID

Removal

1. Remove infeed idler arm ((👉 3.4.4).
2. Remove screws [A] (🔑 x2).

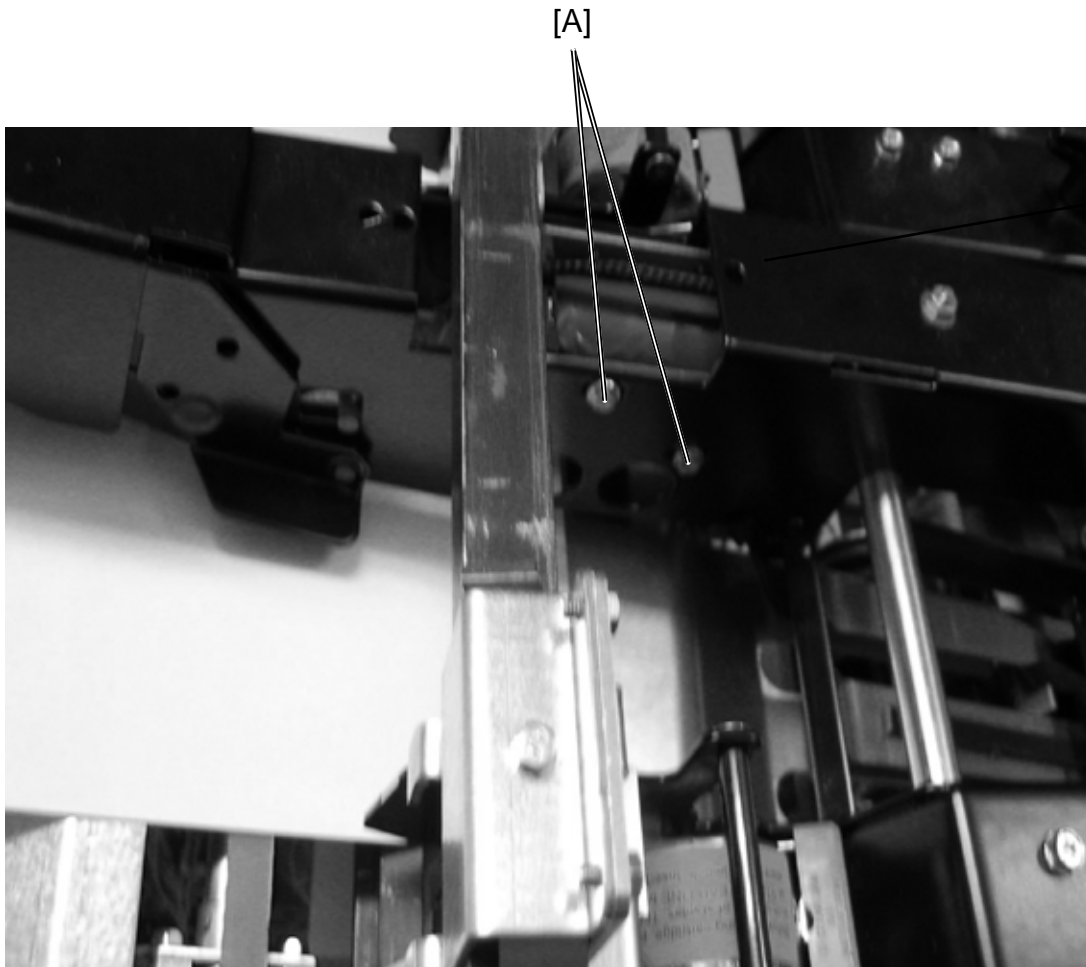



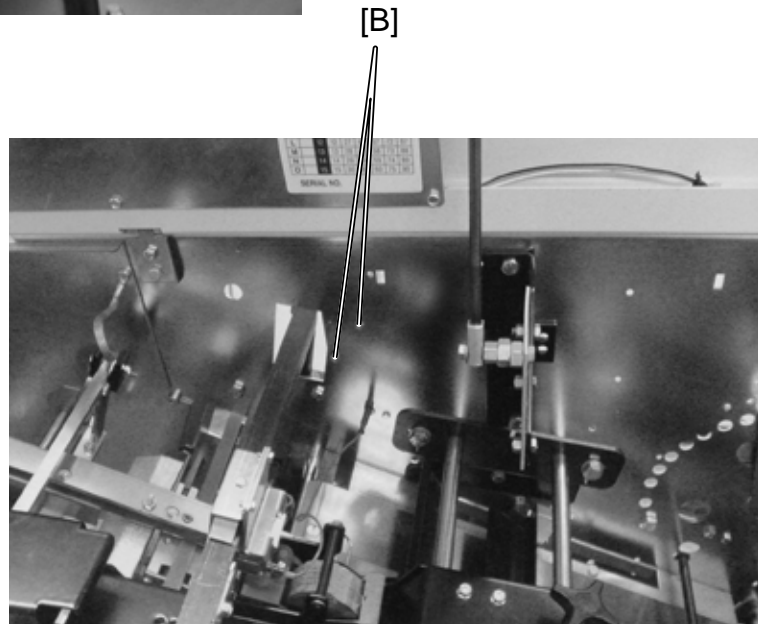
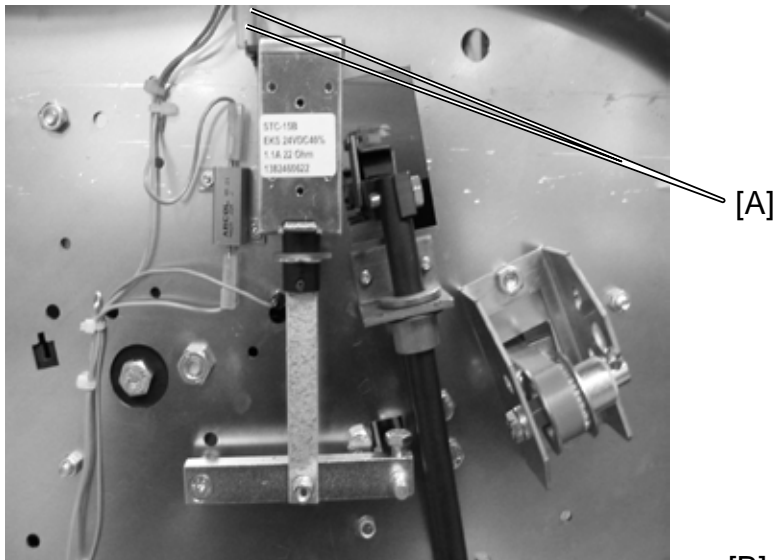

Installation/Adjustment

1. Connect the orange wire to the orange marking on solenoid.
2. Mount idler arm.
3. Make sure there is about 1 mm clearance between solenoid body and plunger when the idler rollers (bearings) contacts the infeed belt.

3.7.2 SOL2/SOL3 STAPLE STOP GATE SOLENOIDS



Removal

1. Remove the Left cover (Front cover ( 3.3.1) or Rear cover ( 3.3.2) depending on model).
2. Disconnect connectors [A] ( x2).
2. Remove solenoid by removing two screws [B] ( x2).

Installation/Adjustment

1. Connect the orange wire to the orange marking on solenoid.
2. When solenoid is activated the plunger should bottom out against the solenoid body.

3.7.3 SOL4 STOP GATE SOLENOID

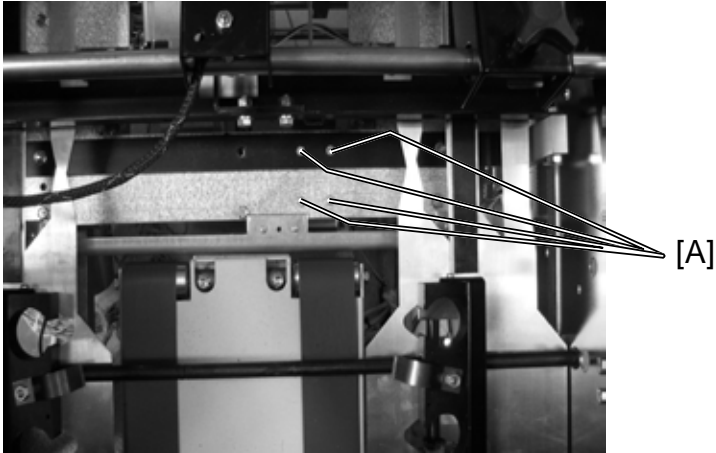

Replacement
Adjustment

Removal

1. Remove Front and Rear cover ((👉 3.3.1, 3.3.2).
2. Remove paper path ((👉 3.3.6).
3. Go to service mode and choose motors.
4. Run motor M6 for access of four screws [A].
5. Disconnect connectors [B] (📏 x2).
6. Remove the screws [A] and remove the solenoid [C] (🔧 x4).

Installation/Adjustment

1. Reverse the removal procedure.
2. Connect the orange wire to the orange marking on solenoid.
3. Adjust solenoid according to ((👉 3.4.5).

Page intentionally blank