

Plockmatic 88 and 102 Stapler Folder

Service Manual



Provided By

MyBinding.com®
When Image Matters.

Stapler Folder Model 88 / 102

Service Manual

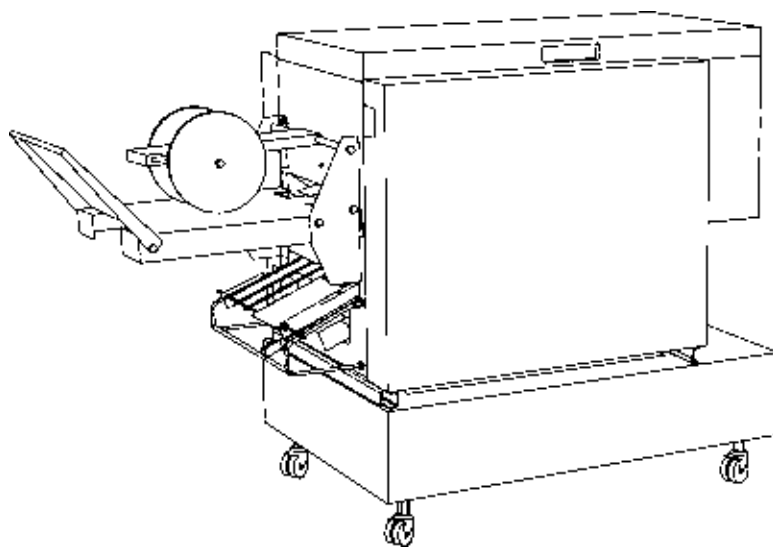
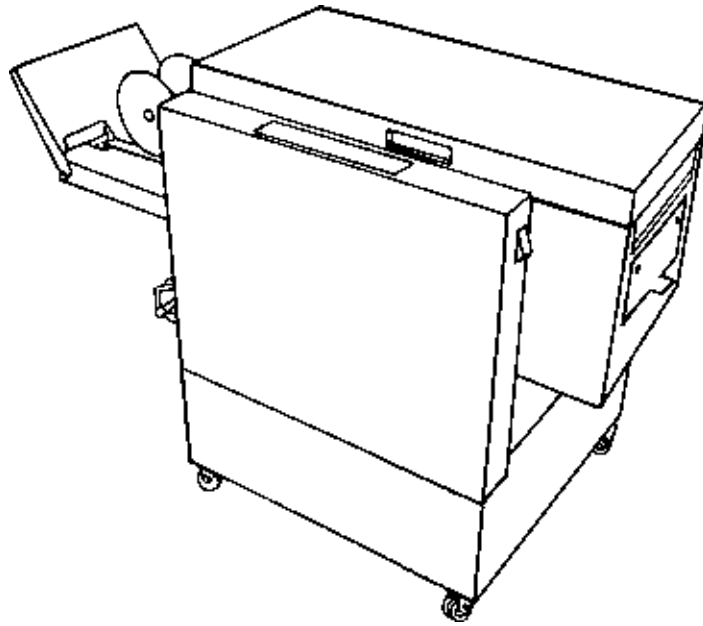

April 2002

Part No. 87609

		Page	Revision
iii	Direction of the Model 88 / 102	iii	April 2002
iiii	Special Tools	iiii	April 2002
 Covers			
REP 1.1	Front, Rear and Infeed Cover	1.1.1	April 2002
REP 1.2	Lower and Upper Outfeed Cover	1.2.1	April 2002
REP 1.3	Deck Plate	1.3.1	April 2002
 Main Assemblies			
REP 2.1	Infeed Module	2.1.1	April 2002
REP 2.2	Infeed Idler Arm Assembly	2.2.1	April 2002
REP 2.3	Stapler Assembly	2.3.1	April 2002
 Sensors and Switches			
REP 3.1	Fold Position Adjustment Sensor (SEN1)	3.1.1	April 2002
REP 3.2	Side Jogger Adjustment Sensor (SEN2)	3.2.1	April 2002
REP 3.3	Back Jogger Adjustment Sensor (SEN3)	3.3.1	April 2002
REP 3.4	Outfeed Sensor (SEN4)	3.4.1	April 2002
REP 3.5	Start Cycle Sensor (SEN5)	3.5.1	April 2002
REP 3.6	Infeed Sensor (SEN6)	3.6.1	April 2002
REP 3.7	Edge Stapling Sensor (SEN14)	3.7.1	April 2002
REP 3.8	Side Jogger Home Position Switch (SW1)	3.8.1	April 2002
REP 3.9	Side Jogger Limit Switches (SW2, SW3)	3.9.1	April 2002
REP 3.10	Side Jogger Motor Off Switch (SW4)	3.10.1	April 2002
REP 3.11	Stapler/Clincher Motor On Switch (SW5)	3.11.1	April 2002
REP 3.12	Stapler/Clincher Home Switch (SW6)	3.12.1	April 2002
REP 3.13	Registration Carriage Limit/Home Pos. (SW7, SW8)	3.13.1	April 2002
REP 3.14	Fold Knife Home Switch (SW9)	3.14.1	April 2002
REP 3.15	Back Jogger Carrier Limit/Home Position (SW15, SW16)	3.15.1	April 2002
REP 3.16	Staple Detection Switches (SW20, SW21)	3.16.1	April 2002
REP 3.17	Interlock Switches (INTLK1, INTLK2)	3.17.1	April 2002
REP 3.18	Interlock Bypass Switch (INTLK3)	4.18.1	April 2002
 Solenoids			
REP 4.1	Registration Stop Solenoid (SOL4)	4.1.1	April 2002
REP 4.2	Back Jogger Solenoid (SOL6)	4.2.1	April 2002
REP 4.3	Edge Staple Stop Solenoid (SOL14)	4.3.1	April 2002
REP 4.4	Edge Stapling Transport Solenoid (SOL18)	4.4.1	April 2002
 Motors and Assemblies			
REP 5.1	Fold Roller Drive Motor (MOT1)	5.1.1	April 2002
REP 5.2	Lower Fold Roller and Ball Bearing	5.2.1	April 2002
REP 5.3	Upper Fold Roller and Ball Bearing	5.3.1	April 2002
REP 5.4	Stapler/Clincher Drive Motor (MOT2)	5.4.1	April 2002
REP 5.5	Clincher Assembly	5.5.1	April 2002
REP 5.6	Clincher Timing and Height	5.6.1	April 2002
REP 5.7	Stapler Compression	5.7.1	April 2002
REP 5.8	Fold Knife Motor (MOT3)	5.8.1	April 2002
REP 5.9	Eject Motor and Drive O-ring (MOT5)	5.9.1	April 2002

REP 5.10	Side Jogger Drive Motor	(MOT7)	5.10.1	April 2002
REP 5.11	Side Jogger Channel Centering		5.11.1	April 2002
REP 5.12	Side Jogger Push Rod Centering		5.12.1	April 2002
REP 5.13	Infeed Belt Motor	(MOT8)	5.13.1	April 2002
REP 5.14	Fold Stop Gate Motor	(MOT9)	5.14.1	April 2002
REP 5.15	Fold Position Adjustment Motor	(MOT15)	5.15.1	April 2002
REP 5.16	Fold Position Adjustment		5.16.1	April 2002
REP 5.17	Back Jogger Adjustment Motor	(MOT16)	5.17.1	April 2002
REP 5.18	Side Jogger Adjustment Motor	(MOT17)	5.18.1	April 2002

O-rings and Drive Belts

REP 6.1	Infeed Drive O-ring		6.1.1	April 2002
REP 6.2	Infeed Belt		6.2.1	April 2002
REP 6.3	Prefold Transport Belt		6.3.1	April 2002

Circuit Boards

REP 7.1	Logic Board	(PCB 88-1)	7.1.1	April 2002
REP 7.2	Motor Drive Board	(PCB 88-2)	7.2.1	April 2002
REP 7.3	Communication PCB		7.3.1	April 2002
REP 7.4	Control Panel		7.4.1	April 2002

Electrical Detail Information

EDI 8.1	Wiring Diagram Model 102		8.1.1	April 2002
EDI 8.2	Wiring/Circuit Diagram Model 88		8.2.1	April 2002
EDI 8.3	Wiring Diagram Model 88		8.3.1	April 2002
EDI 8.4	Staple Detection Wiring Diagram		8.4.1	April 2002
EDI 8.5	Connection Cable Diagram		8.5.1	April 2002
EDI 8.6	PCB Electrical Component Location	(PCB 88-1)	8.6.1	April 2002
EDI 8.7	PCB Electrical Component Location	(PCB 88-1)	8.7.1	April 2002
EDI 8.8	PCB Electrical Component Location	(PCB 88-2)	8.8.1	April 2002
EDI 8.9	PCB Electrical Component Location	(PCB 88-2)	8.9.1	April 2002

Programming

PRG 9.1	Reset EEPROM		9.1.1	April 2002
PRG 9.2	Set up Paper Size & Store into Operator Memory		9.2.1	April 2002
PRG 9.3	Store Paper Size into Factory Memory		9.3.1	April 2002
PRG 9.4	Retrieve Paper Size from Factory Memory		9.4.1	April 2002
PRG 9.5	Increasing/Decreasing Software Time Delays		9.5.1	April 2002

Fault Isolating Procedure

FIP 10.1	Diagnostic Component Control		10.1.1	April 2002
FIP 10.2	Fault Isolating Procedure		10.2.1	April 2002

Maintenance

MAI 11.1	Preventive Maintenance		11.1.1	April 2002
----------	------------------------	--	--------	------------

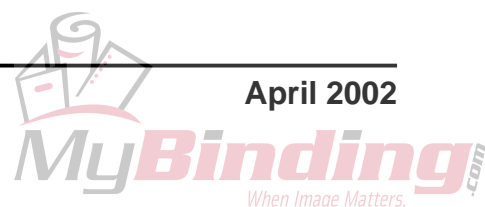

This service manual cover both Model 88 and Model 102. The two models have the same base design. Therefor many parts, components and adjustments are common. Where nothing else is indicated throughout the manual, the instruction is common for the two models.

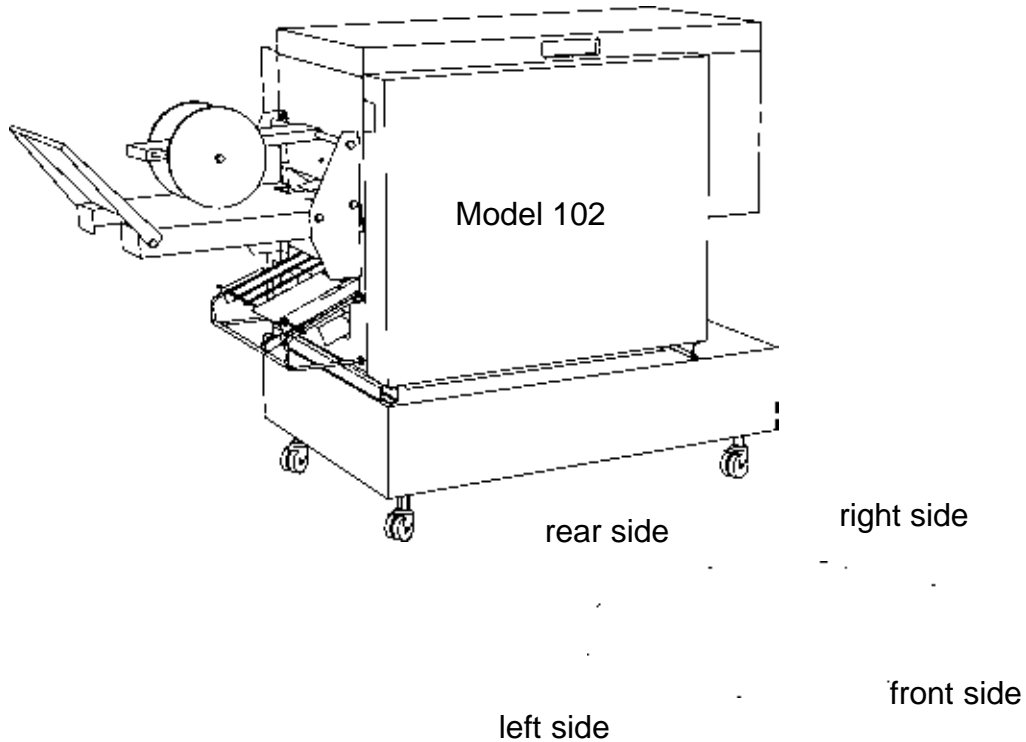
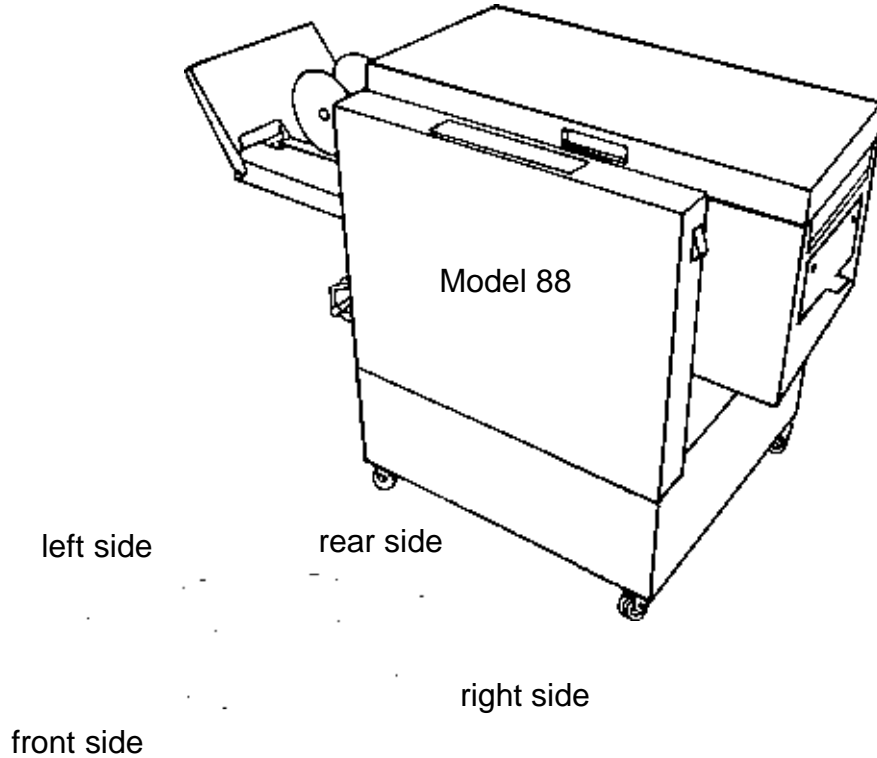

In order to facilitate the service of the Model 88/102 there are a few special tools available.

Hand crank generator.
Part no. 551249

ESD Ground strap.
Part no. 901044



REMOVAL

Front and Rear Cover

1. Switch off the main power and disconnect the power cord.
2. Loosen the two screws (1) at bottom of cover.
CAUTION: There is a ground strap attached to the centre of the cover. Pull out bottom and disconnect ground strap before lifting cover off.
3. Lift cover off.

Infeed Cover Removal

1. Switch off the main power and disconnect the power cord.
2. Disconnect connection cables.
3. Loosen the two screws (2) at (Model 102).
4. Remove the two screws (3)
5. Pull out bottom and lift cover off.

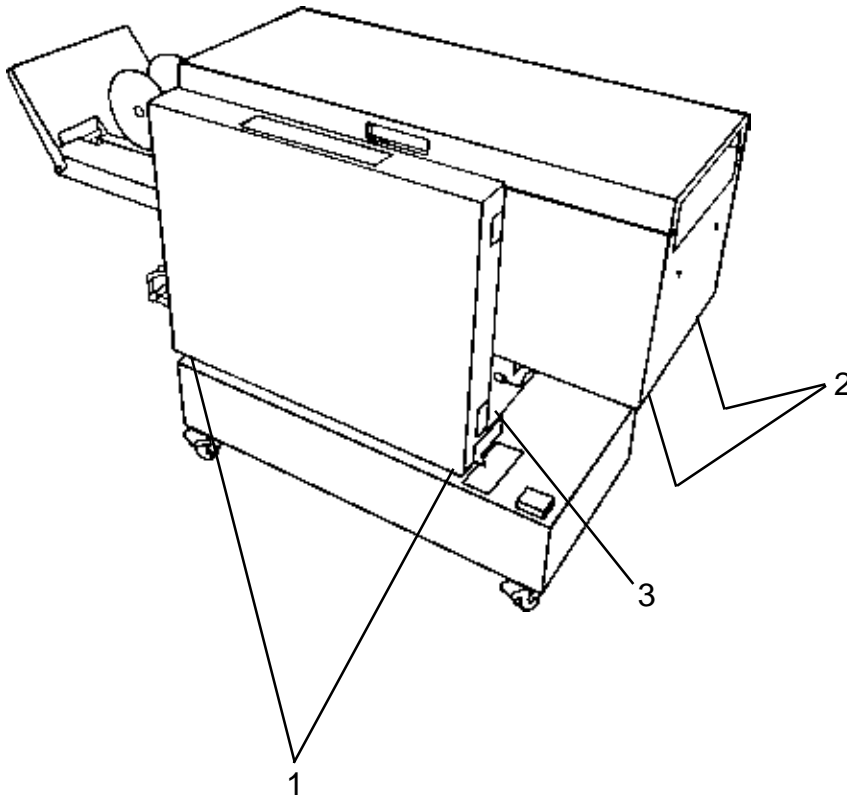

INSTALLATION

Installation is an exact reversed procedure of removal.

REMOVAL

Lower Outfeed Cover

1. Switch off the main power and disconnect the power cord.
2. Remove trimmer unit if any or belt stacker.
3. Loosen the two screws (1) at the bottom of cover.
4. Remove the two screws (2) at the surface of the cover

INSTALLATION

Installation is an exact reversed procedure of removal.

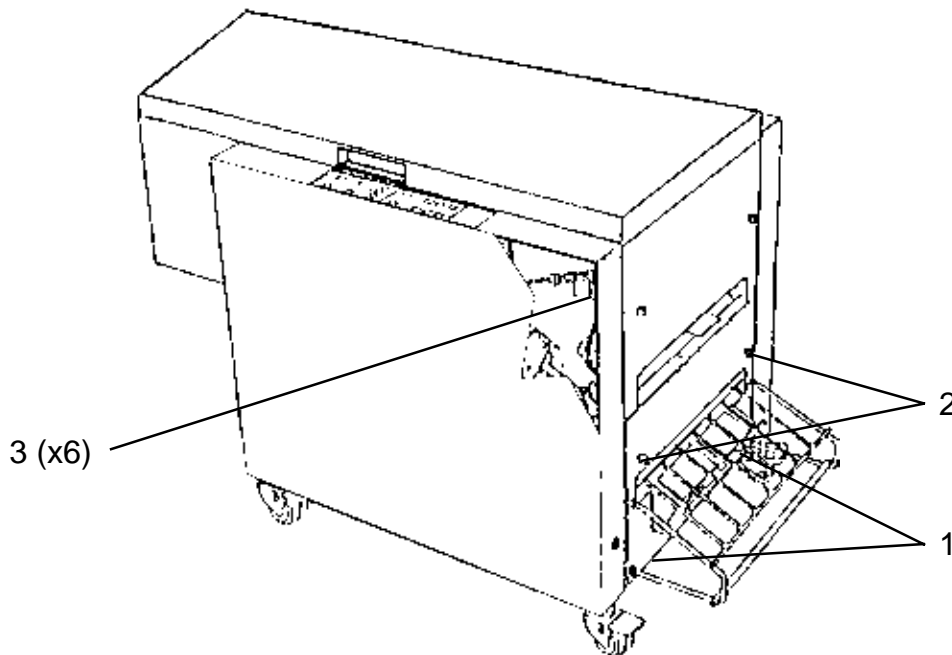

REMOVAL

Upper Outfeed Cover

1. Switch off the main power and disconnect the power cord.
2. Remove trimmer unit if any or belt stacker.
3. Remove the slide stay from the top cover.
4. Disconnect the exit sensor and remove the sensor wires from the cover.
5. Loosen the two screws holding the interlock switches and lift out the switches.
6. Remove the six screws (3) that are mounting the cover to the side frames.

INSTALLATION

1. Installation is an exact reversed procedure of removal.
2. Adjust the Outfeed sensor according to REP 3.4.
3. Adjust the interlock switches according to REP 3.17.

REMOVAL

1. On the control panel, adjust the side guides to the widest position and the stop gate to the middle position.
2. Switch off the main power and disconnect the power cord.
3. Remove front and rear cover according to REP 1.1.
4. Remove infeed module according to REP 2.1.
5. Remove the guide plates (2), note the location before removal.
6. Remove the six screws (1) along the sides of the deck plate.
7. Move the front ball cage guide to reveal the counter sunk screw (on Model 102). Remove the screw.
8. Push down the stop gate and remove the deck plate through the fold area.

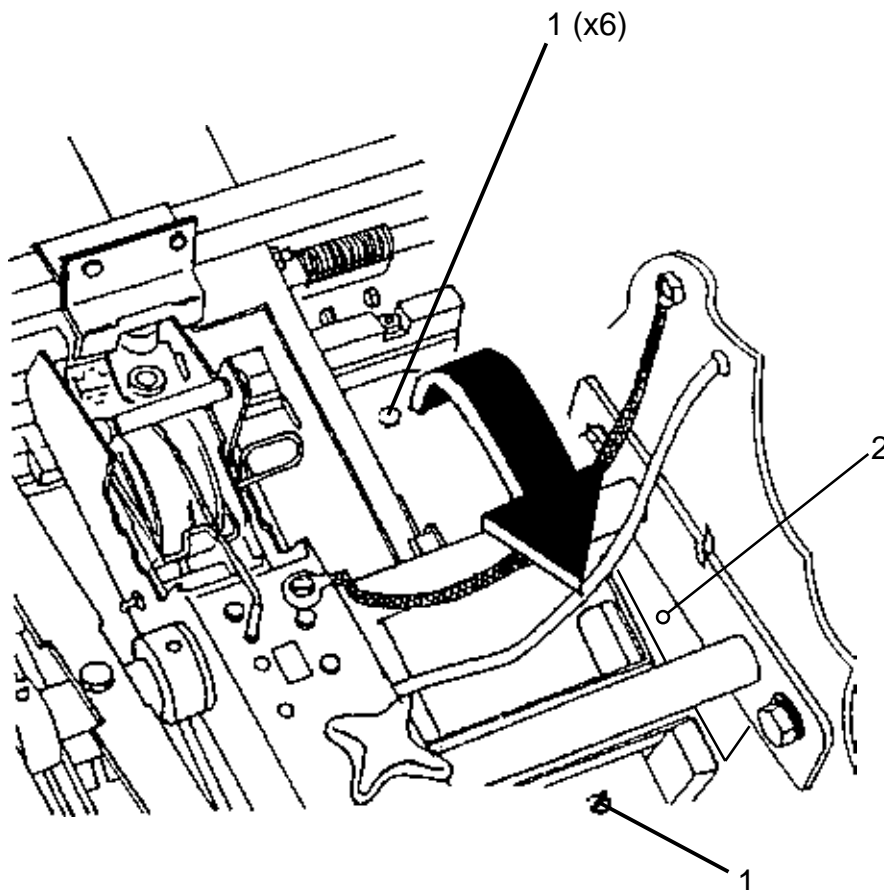

INSTALLATION

Installation is an exact reversed procedure of removal.

CAUTION: *Tighten the screws with a matched screw driver so no burrs will arise on the screw head. Check for burrs and polish, using a very fine emery cloth, if needed.*

REMOVAL

1. On the control panel, adjust the side guides to the widest position.
2. Switch off the main power (1) and disconnect the power cord.
3. Remove the Infeed cover (2) according to REP 1.1.
4. Disconnect the three middle plugs under the infeed module (3).
5. Remove the idler roller shaft (4) by removing the screws on each end.
For Model 88 only: Remove idler paper path.
6. Remove the two screws (5).
7. Lift out the infeed module.

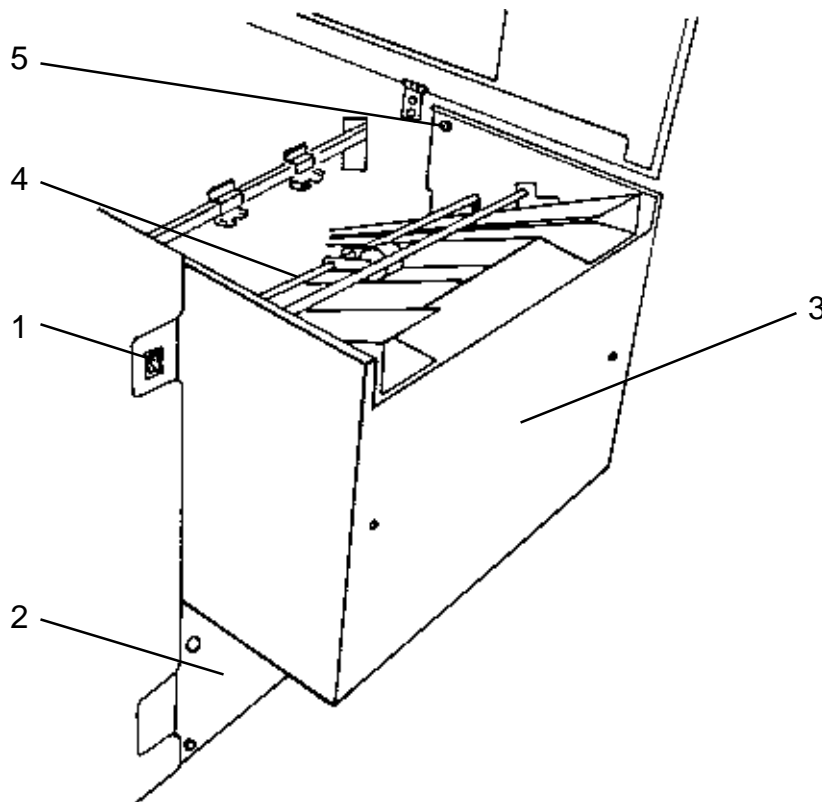

INSTALLATION

Installation is an exact reversed procedure of removal.

REMOVAL

1. From the control panel, select A3 (8.5"x17") size.
2. Switch off the main power and disconnect the power cord.
3. Open the top cover.
4. Loosen the knobs (1).
4. Move stapler assemblies to the sides
5. Remove the two screws (2) and nuts and washers below.
6. Unhook the paper guide extensions (3) from the holes in the idler arm assembly.
7. Turn the idler arm assembly (4) over.
8. Disconnect the plug (5).
9. Remove the idler arm assembly (4).

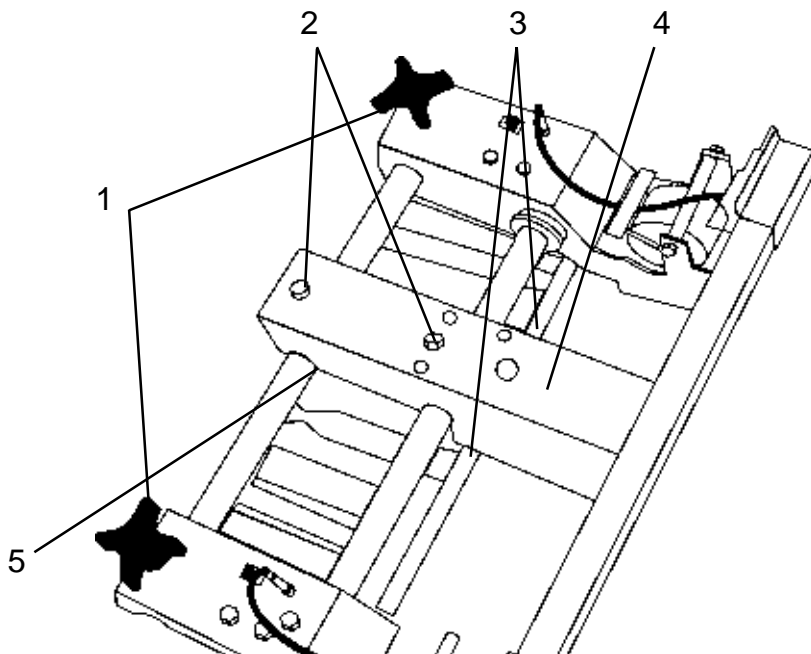

INSTALLATION

Installation is an exact reversed procedure of removal.

CAUTION: Make sure the paper guide extensions (2) are properly seated in the holes of the idler arm assembly.

REMOVAL

1. From the control panel, select A3 (8.5"x17") size.
2. Switch off the main power and disconnect the power cord.
3. Remove the front and rear cover according to REP 1.1 and safety guard.
4. Remove the stapler heads.
5. Remove the stapler bar (1) by removing the screws on each end.
6. Remove bolts in each end of rod (2) from the outside of the side frames.
CAUTION: Do not loosen the red painted bolts.
7. Loosen the knobs (3) and move stapler assemblies to the sides to gain more slack in the wires.
8. Tilt the whole assembly up and backwards to access the underside of the stapler assemblies.
9. To remove the whole stapler assembly:
Remove bolts in each end of rod (4) from the outside of the side frames.
Note the position of the wires and disconnect.

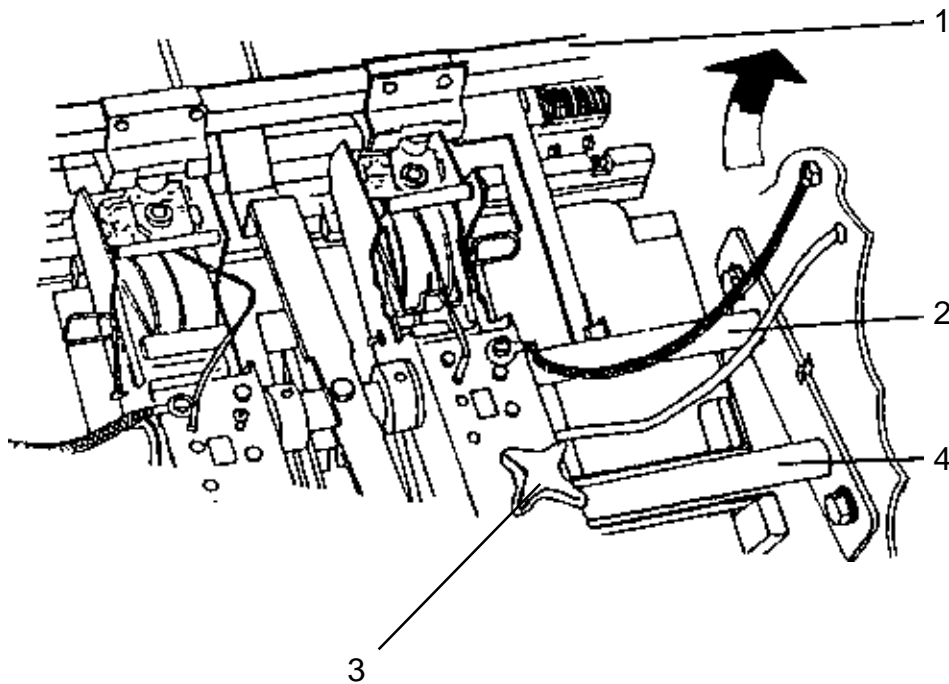

INSTALLATION

Installation is an exact reversed procedure of removal.

REMOVAL

1. Switch off the main power and disconnect the power cord.
2. Remove front cover according to REP 1.1 and safety guard.
3. Note position of connectors (1) and sensor orientation.
4. Disconnect the plugs from the sensor
5. Remove sensor by removing screws and nuts.

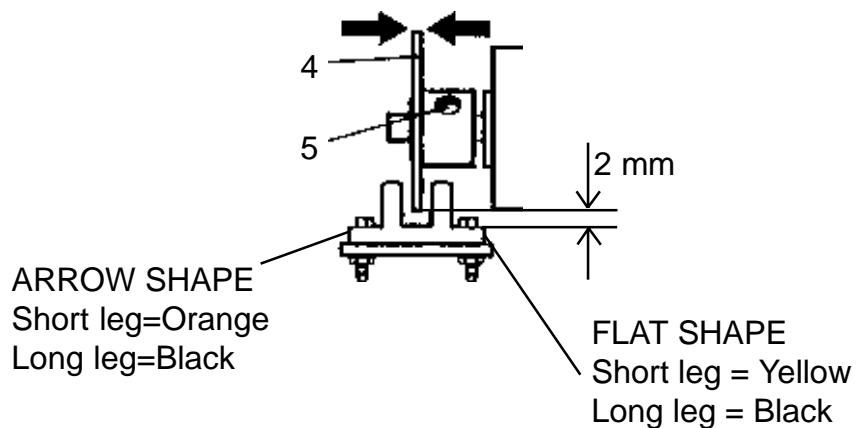
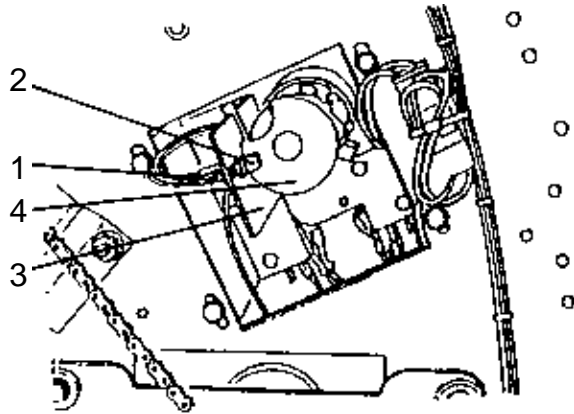

INSTALLATION

Installation is an exact reversed procedure of removal.

ADJUSTMENT

1. Move sensor bracket (3) until 2mm gap between bottom of sensor and disc is obtained.
2. Center the disc on motor shaft in sensor opening.
Loosen set screws (5) and move disc if necessary.

REMOVAL

1. Switch off the main power and disconnect the power cord.
2. Remove Infeed cover according to REP 1.1.
3. Note position of connectors (1) and sensor orientation.
4. Loosen the screws (2) and remove sensor bracket (3)
5. Disconnect the plugs (1) from the sensor.
6. Remove sensor.

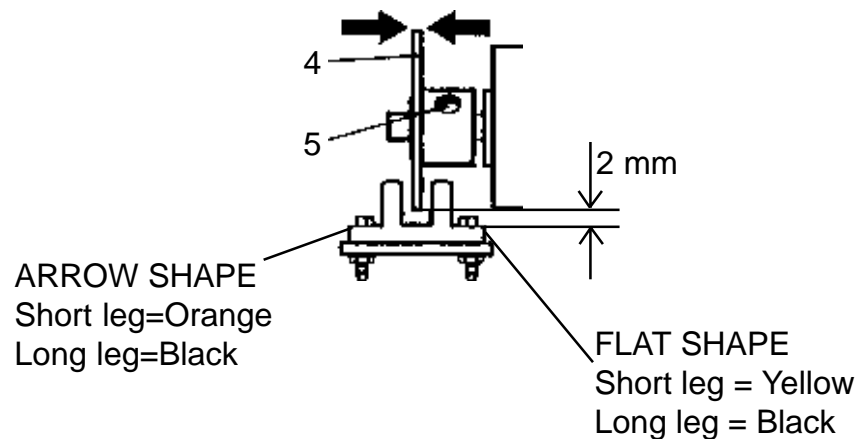
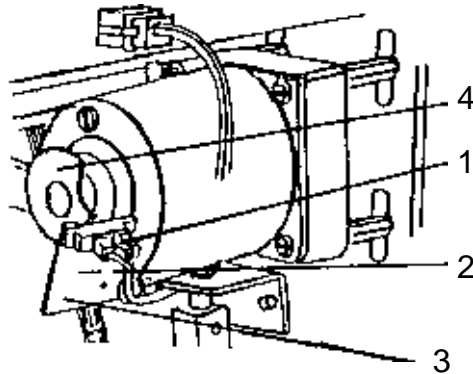

INSTALLATION

Installation is an exact reversed procedure of removal.

ADJUSTMENT

1. Move sensor bracket (3) until 2mm gap between bottom of sensor and disc is obtained.
2. Center the disc on motor shaft in sensor opening.
Loosen set screws (5) and move disc if necessary

REMOVAL.

1. On the control panel, adjust the machine into A4 (8.5x11") position and then adjust the side guides to the widest position.
2. Switch off the main power switch and disconnect the power cord.
3. Remove the infeed module according to REP 2.1.
4. Disconnect the drive O-ring.

Model 88

5. Loosen the four nuts holding infeed paper path.
6. Carefully lift out paper path.
7. Note the orientation of connectors (1) wire colours and sensor orientation/ markings.
8. Disconnect leads from sensor pins.
9. Remove the two screws (3) holding the sensor bracket (4).

Model 102

5. Remove the four small shafts that the infeed belt is routed around.
6. Loosen the four nuts holding bracket for the whole carriage assembly.
7. Carefully pull out the whole assembly.
8. Note the orientation of connectors (1), wire colours and sensor orientation/ markings.
9. Disconnect leads from sensor pins.
10. Remove the two screws holding the sensor (2).

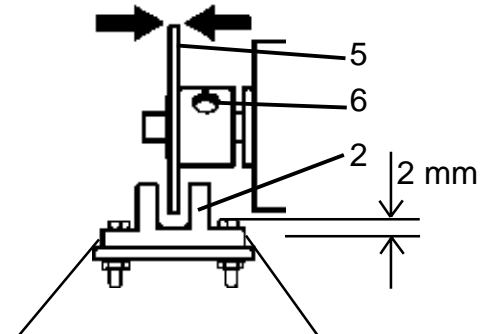
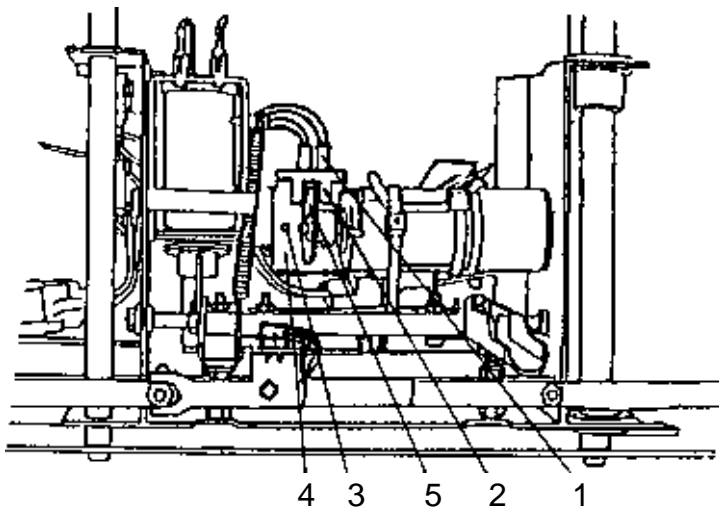

ARROW SHAPE
Short leg=Orange
Long leg=Black

FLAT SHAPE
Short leg = Yellow
Long leg = Black

INSTALLATION

Installation is an exact reversed procedure of removal.

ADJUSTMENT

1. For Model 88 only (bracket for Model 102 is fixed):
Move bracket (4) until 2mm gap is obtained between bottom of sensor and disc (5).
2. Center the disc on motor shaft in sensor opening. Loosen set screws (6) and move disc if necessary.

CAUTION: Ensure that the disc does not touch the sensor side.

REMOVAL

LED

1. Switch off the main power and disconnect the power cord.
2. Disconnect and remove belt stacker or Trimmer if installed.
3. Remove the lower outfeed cover according to REP 1.2.
4. Remove the LED bracket (1).
5. Note the position of the wires and remove the plug.
6. Remove the LED.

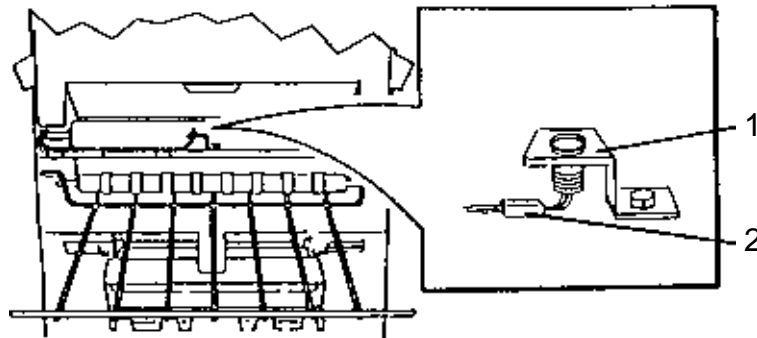

Sensor

1. Switch off the main power and disconnect the power cord.
2. Disconnect and remove belt stacker or Trimmer if installed.
3. Remove the nut holding the sensor bracket and remove bracket.
4. Note the position and colour of the wires and remove the plug.
5. Remove the sensor.

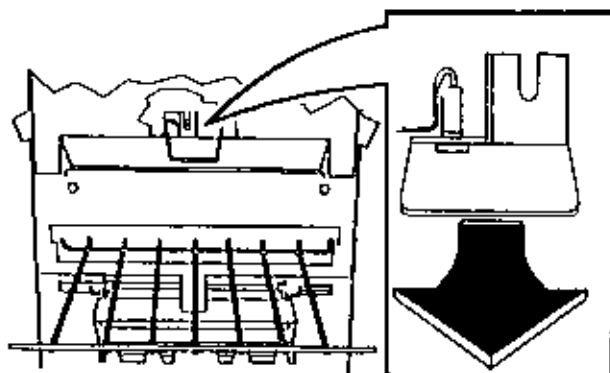

INSTALLATION

Installation is an exact reversed procedure of removal.

Note: If the sensor is adjusted incorrectly or dirty, false trimmer jam can occur if a trimmer is installed.

ADJUSTMENT

1. Remove the rear cover and pull out the interlock bypass switch.
2. Connect the power cord and switch on the main power switch.

If Trimmer is installed

3. Measure voltage between TP2 on Trimmer PCB and common ground.
 - With the sensor path clear >14 VDC
 - With the sensor path blocked <1 VDC

If only Stacker is installed

3. Measure voltage between J1-18A and common ground.
 - With the sensor path clear <6 VDC
 - With the sensor path blocked >8 VDC

MACHINE CYCLE

In order for the jogger action, stapling cycle etc. to proceed: Start cycle sensor must be blocked and Infeed sensor clear.

REMOVAL

Sensor

1. Switch off the main power and disconnect the power cord.
2. Trace wires (1) to terminal block.
Note the position and the colour of the wires and remove wires.
3. Remove screws (2) and remove the sensor (3).

NOTE: If screws are unaccessible; move carriage (MOT15) towards the outfeed using the diagnostic component control according to FIP 10.1 or using the hand crank generator.

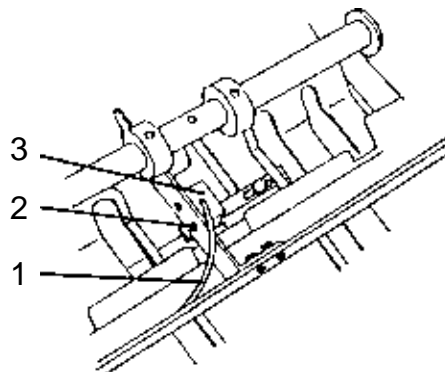

LED

1. Switch off the main power and disconnect the power cord.
2. Remove the infeed module according to REP 3.10.
3. Open the top cover.
4. Move the stapler heads toward the side frames.
5. Hold the LED with a pair of pliers. Remove the screw and washer (4).

NOTE: If screws are unaccessible; move carriage (MOT15) towards the outfeed using the diagnostic component control according to FIP 10.1 or using the hand crank generator.

6. Disconnect wires from the LED and remove LED from the bracket.

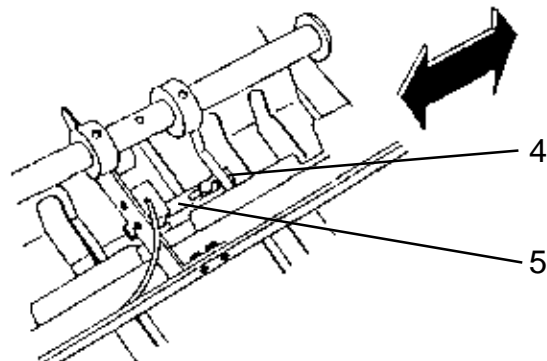

INSTALLATION

Installation is an exact reversed procedure of removal.

ADJUSTMENT

1. Remove the rear cover and pull out the interlock bypass switch.
2. Connect the power cord and switch on the main power switch.
3. Measure voltage between J1-8C and common ground.
 - With the sensor path clear <6 VDC
 - With the sensor path blocked >8 VDC

MACHINE CYCLE

In order for the jogger action, stapling cycle etc. to proceed: Start cycle sensor must be blocked and Infeed sensor clear.

- If Infeed sensor is functioning: Start cycle sensor is blocked, machine waits for the Infeed sensor to be cleared. When cleared; the jogger action, stapling cycle etc. will start.
- If Infeed sensor is faulty (always clear): The jogger action, stapling cycle etc. will start immediately when Start cycle sensor is blocked, resulting in the sets being stapled shingled.
- If Infeed sensor is faulty (always blocked): The paper jam indicator on the control panel will come on after a few seconds.

ADJUSTMENT

1. Open the top cover.
2. Make sure the sensor actuator moves freely without binding.
3. Make sure the sensor actuator sticks up in the paper path enough to actuate the sensor when sheets are passing.

Form the actuator bracket if necessary (on Model 88 only, for Model 102 the position is fixed).

4. Remove the rear cover and pull out the interlock bypass switch.
5. Connect the power cord and switch on the main power switch.
6. Measure voltage between J1-12C and common ground.
 - With the sensor clear <6 VDC
 - With the sensor blocked >8 VDC

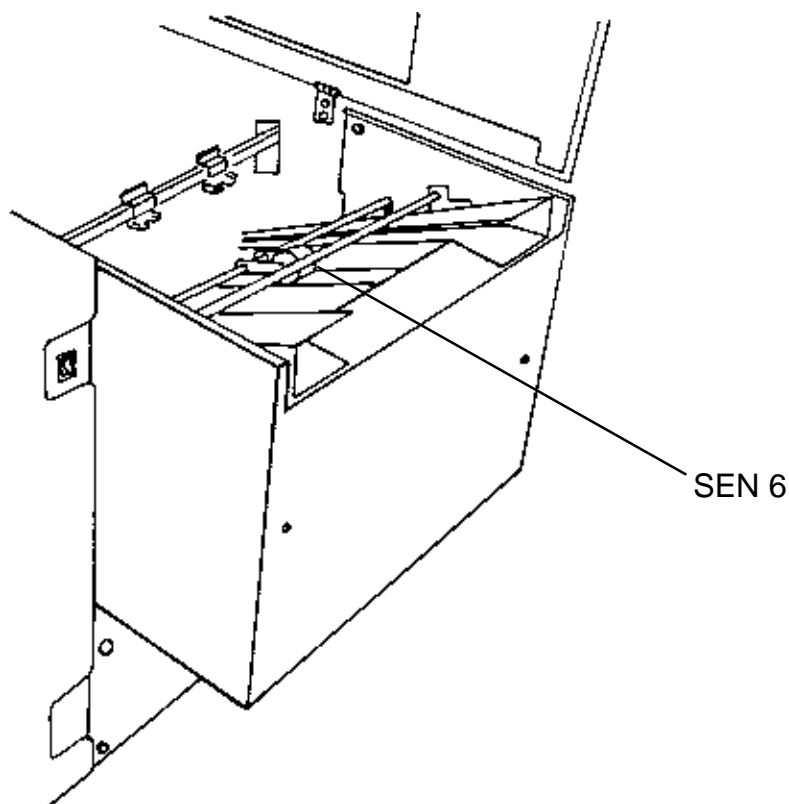

REMOVAL

1. Remove the infeed idler arm assembly according to REP 2.2.
2. Note the position of the sensor wires and remove the plug.
3. Remove the LED (1) by loosening the nut.
4. Remove the sensor by removing the sensor bracket opposite the LED.

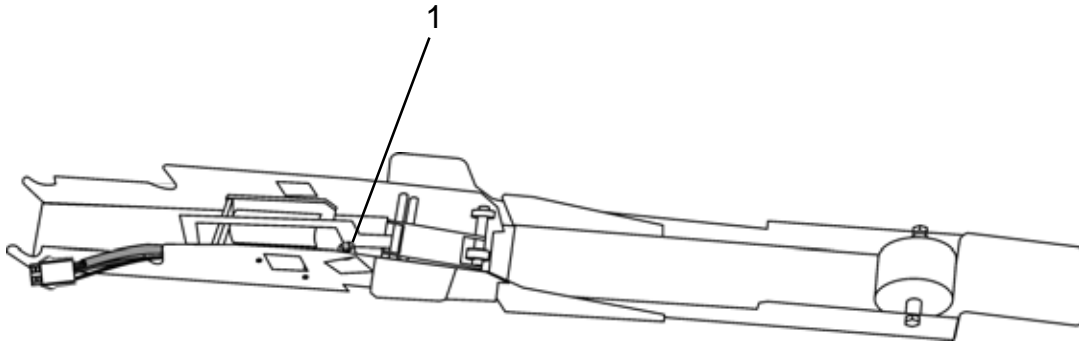
**INSTALLATION**

Installation is an exact reversed procedure of removal.

ADJUSTMENT

1. Remove the rear cover and pull out the interlock bypass switch.
2. Connect the power cord and switch on the main power switch.
3. Measure voltage between J1-8A and common ground.
 - With the sensor clear <6 VDC
 - With the sensor blocked >8 VDC

REMOVAL

1. Remove the in feed module according to REP 2.1.
 2. Remove switch by removing screws (1).
- NOTE: Use tape to keep the nut plate in position, while changing the switch.**
3. Transfer the leads from old switch to corresponding terminals on new switch.

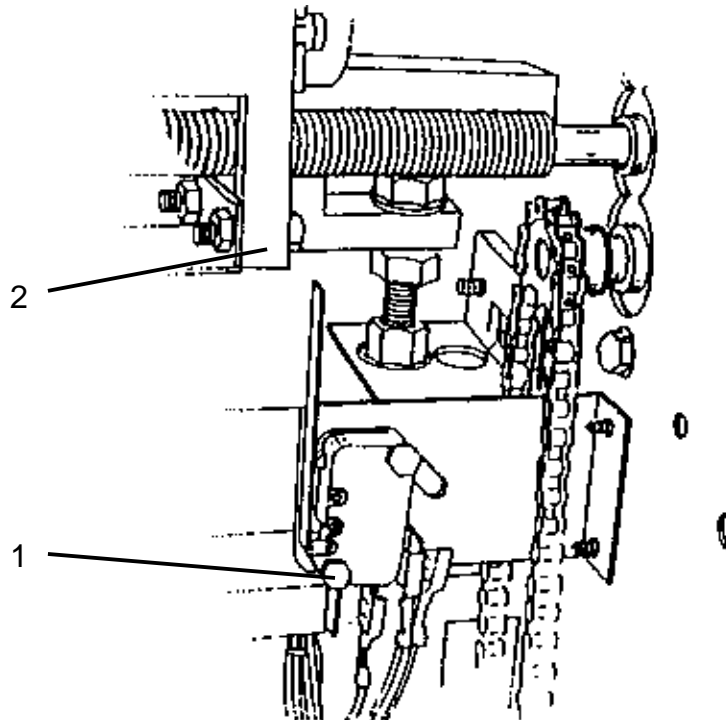

INSTALLATION

Installation is an exact reversed procedure of removal.

ADJUSTMENT

1. Check the side jogger channel centering according to REP 5.11.

Model 88

2. Adjust side jogger home switch so that it actuates when there is a 40mm distance between side jogger (inbetween side jogger and mounting block (2)) and side frame.

Model 102

2. Adjust side jogger home switch so that it actuates when there is a 1mm distance between side jogger (end of long nuts fastening side guides) and side frame.

3. Make sure the largest specified sheet size can be run. If not, adjust the switch to make it possible without reaching mechanical stop.
4. If the switch position has been altered, the factory set paper sizes must be reprogrammed according to PRG 9.2 - 9.3.

REMOVAL

1. Switch off the main power switch and disconnect the power cord.
2. Access the underside of the stapler head assembly according to REP 2.3.
3. Unsolder wires and remove the switch (1).

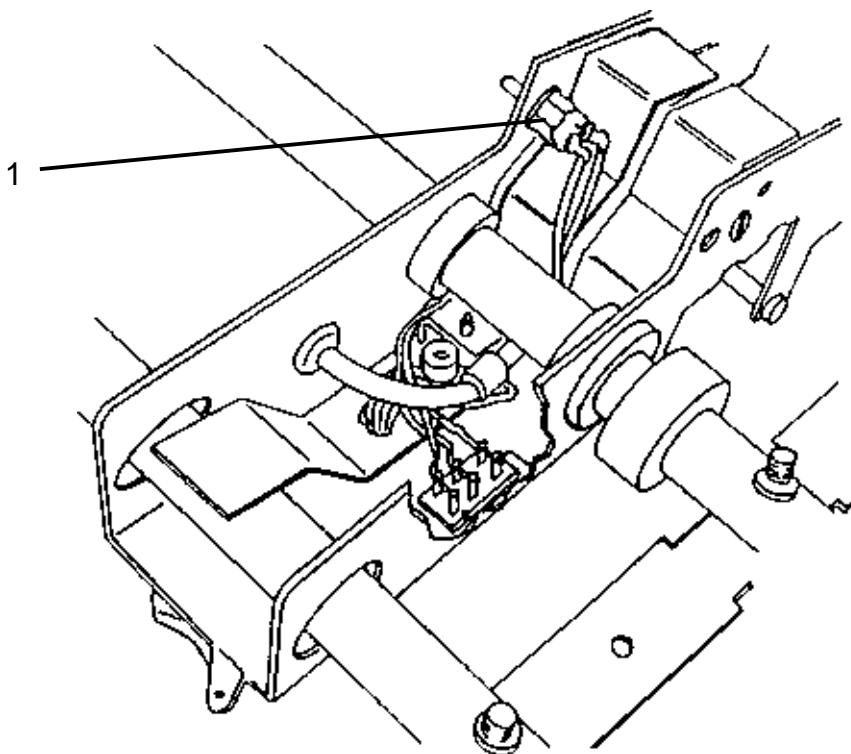

INSTALLATION / ADJUSTMENT

1. Mount and solder new switch.
2. Fit stapler holders into place.
3. Make sure the smallest specified sheet size can be run. If not, adjust the switch actuator screw on the side guide to make it possible without reaching mechanical stop.

REMOVAL

1. Switch off the main power switch and disconnect the power cord.
2. Remove front cover according to REP 1.1.
3. Note the position of inner/outer switch and remove screws (1) and lift out switches.

NOTE: Use tape to keep the nut plate in position, while changing the switch.

4. Transfer leads from old switch to the corresponding terminal on new switch.

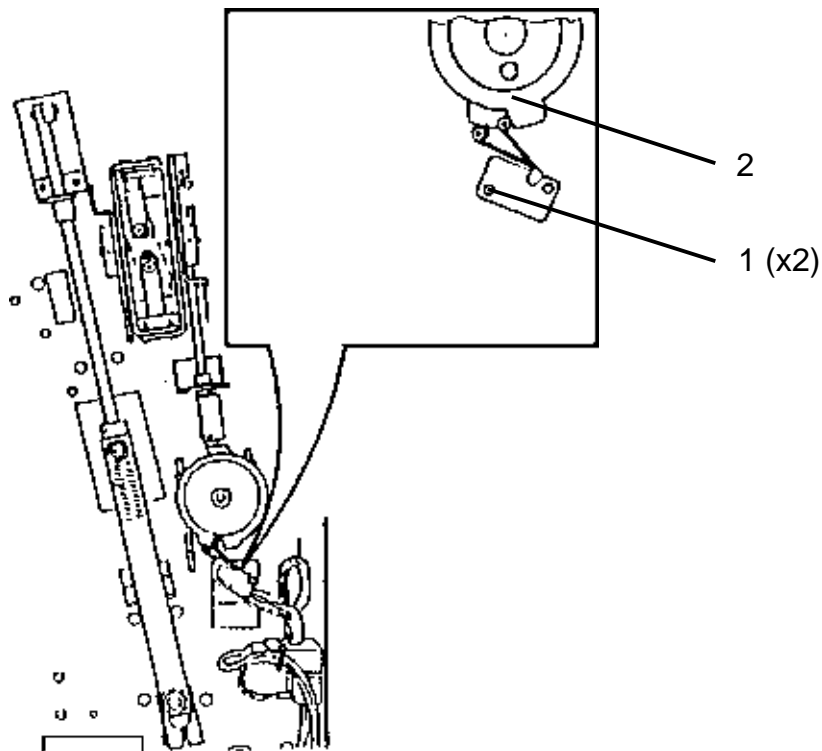

INSTALLATION / ADJUSTMENT

1. Switch 4 should be placed inside the switch 5.
2. Rotate the jogger cam (2) clockwise until push rod is seated on cam lobe.
3. Adjust until switches is fully actuated but not bottomed out.

REMOVAL

1. Switch off the main power and disconnect the power cord.
2. Remove front cover according to REP 1.1.
3. Note the position of inner/outer switch and remove screws(1) and lift out switches.

NOTE: Use tape keep the nut plate in position, while changing the switch.

4. Transfer leads from old switch to the corresponding terminal on new switch.

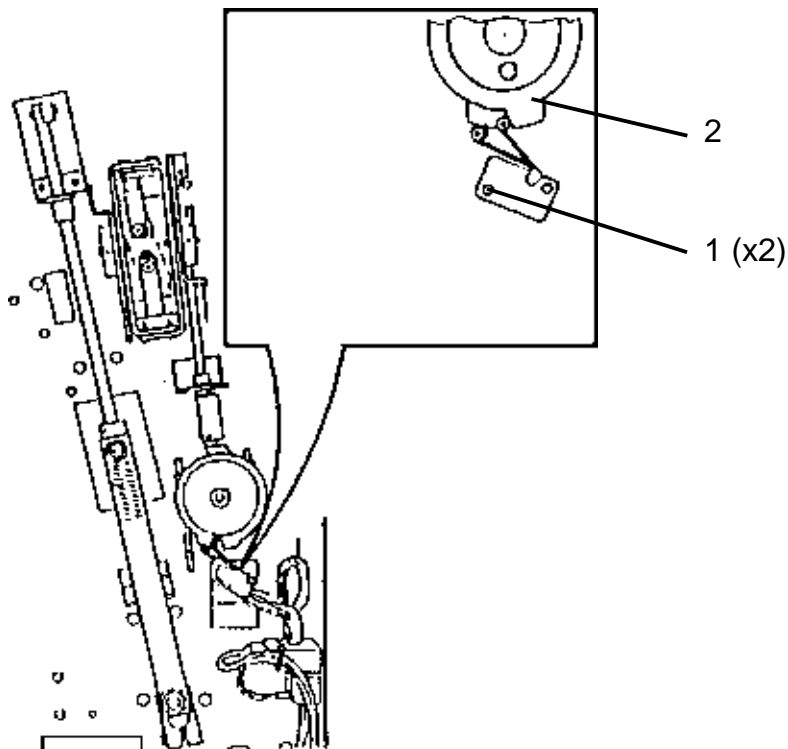

INSTALLATION / ADJUSTMENT

1. Switch 5 should be placed outside the switch 4.
2. Rotate the jogger cam (2) clockwise until push rod is seated on cam lobe.
3. Adjust until switches is fully actuated but not bottomed out.

REMOVAL

1. Switch off the main power switch and disconnect the power cord.
2. Remove infeed cover according to REP 1.1.
3. Remove the switch by removing the two screws (1).
NOTE: Use tape to keep the nut plate in position, while changing the switch.
4. Transfer the leads of old switch to corresponding terminal on new switch.

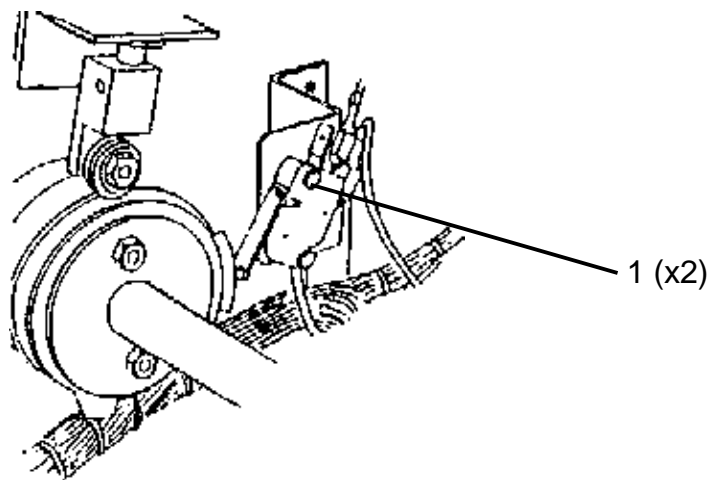

INSTALLATION

Installation is an exact reversed procedure of removal.

ADJUSTMENT

1. Ensure that the actuated roller is near the center of the cam lobe.
2. Adjust until switches is fully actuated but not bottomed out.
3. Check the clincher timing according to REP 5.6.

REMOVAL

1. Switch off the main power switch and disconnect the power cord.
2. Remove front cover according to REP 1.1.
3. Remove the infeed cover according to REP 1.1.

NOTE: Use tape to keep the nut plate in position, while changing the switch.

4. Remove the old switch by removing the two screws (1 for the home position switch or 2 for the limit switch).

CAUTION: Always exchange one switch at a time, to prevent exchanging of switches position.

5. Transfer the leads from the old switch to corresponding terminal on new switch.

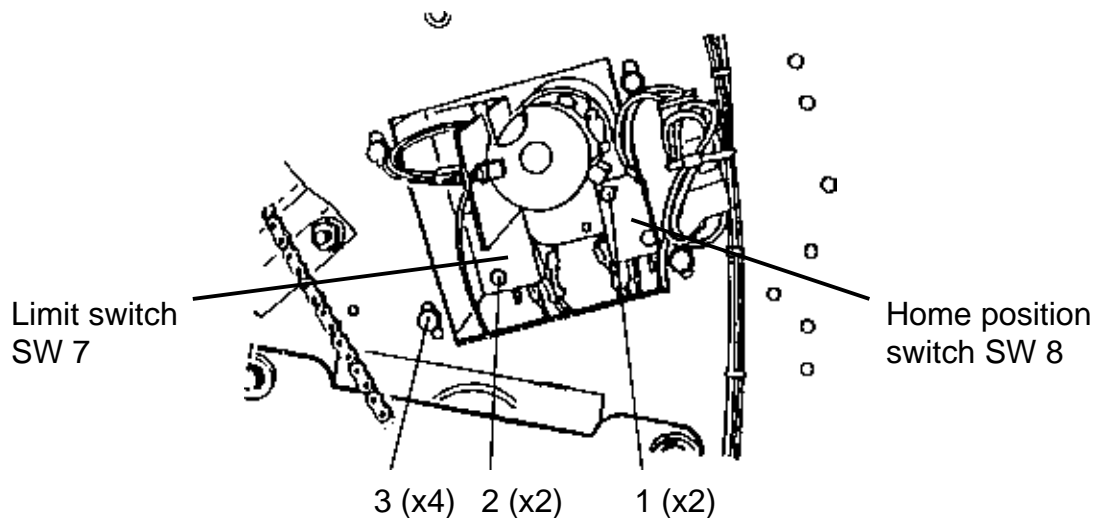

INSTALLATION

Installation is an exact reversed procedure of removal.

ADJUSTMENT

1. Loosen the motor bracket screws (3) to be able to move carriage to the limit or home position. Or use the hand crank generator on the adjustment motor to move the carriage to limit or home position.

CAUTION: Hold carriage while loosening the fourth screw.

2. Adjust with screw (1 or 2) until the switch is actuated 2-3 mm before mechanical end of travel.
3. Make sure the largest and smallest specified sheet size can be run. If not, adjust the switch to make it possible without reaching mechanical stop.
4. If the switch position has been altered, the factory set paper sizes must be reprogrammed according to PRG 9.2 - 9.3.

REMOVAL

1. If a trimmer is installed, remove trimmer.
2. Switch off the main power switch and disconnect the power cord.
3. Remove lower outfeed cover according to REP 1.2.
4. Remove front cover according to REP 1.1.
5. Cut the cable-tie (1) from the wires.
6. Remove the two screws (2).
- NOTE: Use tape to keep the nut plate in position, while changing the switch.**
7. Lift out switch with wires, nut plate and switch spacer.
8. Note the position of the wires and exchange the switch.

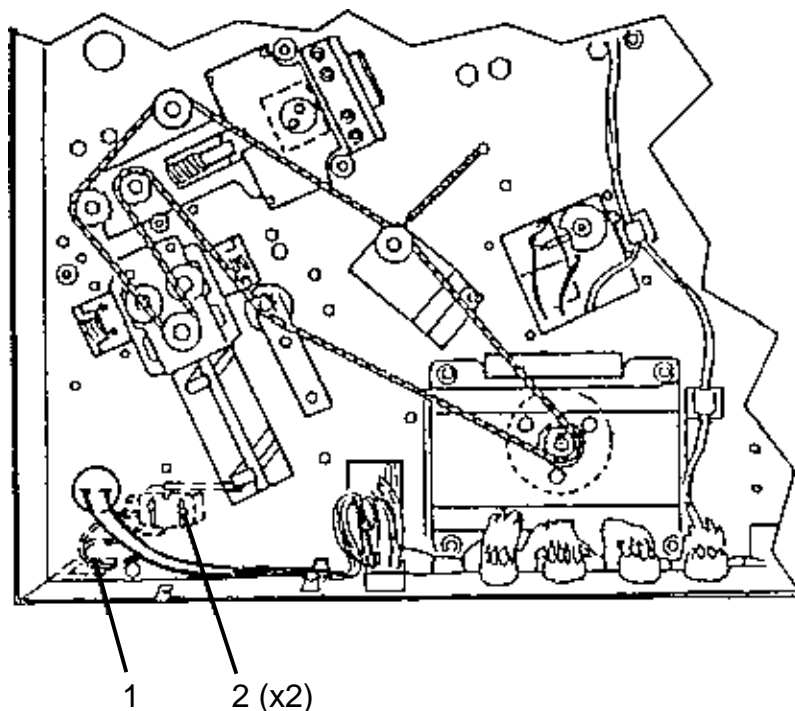

INSTALLATION

Installation is an exact reversed procedure of removal.

ADJUSTMENT

1. Switch actuator arm should be placed in middle position of the switch.
2. With the knife in bottom position (against mechanical stop), there should be 0.1-1mm play between switch arm and knife beam when switch arm is bottomed out.
- NOTE: The knife cam follower is normally outside cam in home position which allows performing the adjustment.**

REMOVAL

1. Switch off the main power switch and disconnect the power cord.
2. Remove infeed cover according to REP 1.1.
NOTE: Use tape to keep the nut plate in position, while changing the switch.
3. Remove the bad switch by removing the two screws (1 for the home position switch or 2 for the limit switch).
CAUTION: Always exchange one switch at a time, to prevent exchanging of switches position.
4. Transfer the leads from the old switch to corresponding terminal on new switch.

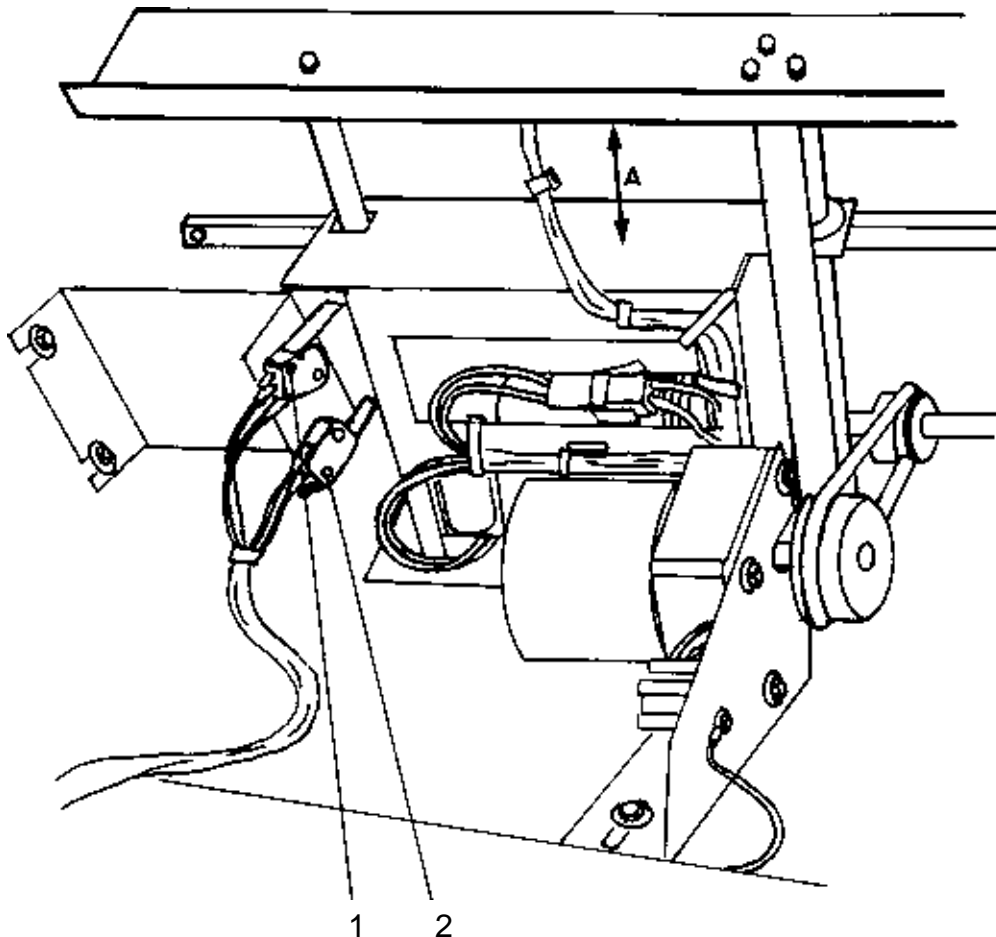

ADJUSTMENT

Model 88

Model 102

- | | |
|---|---|
| <ol style="list-style-type: none"> 1. Adjust switch by screw (1 or 2) until actuated when distance A is:
 10-11mm Limit position
 99-100mm Home position 2. Make sure the largest and smallest specified sheet size can be run. If not, adjust the switch to make it possible without reaching mechanical stop. 3. If the switch position has been altered, the factory set paper sizes must be reprogrammed according to PRG 9.2 - 9.3. | <ol style="list-style-type: none"> 1. Adjust switch by screw (1 or 2) until actuated 1-2mm form mechanical stop. |
|---|---|

REMOVAL

1. Switch off the main power switch and disconnect the power cord.
2. Access the underside of the stapler assembly according to REP 2.3.
3. Note the position of the wires.
4. Unsolder wires (1).
5. Hold the switch (2) while removing screws.

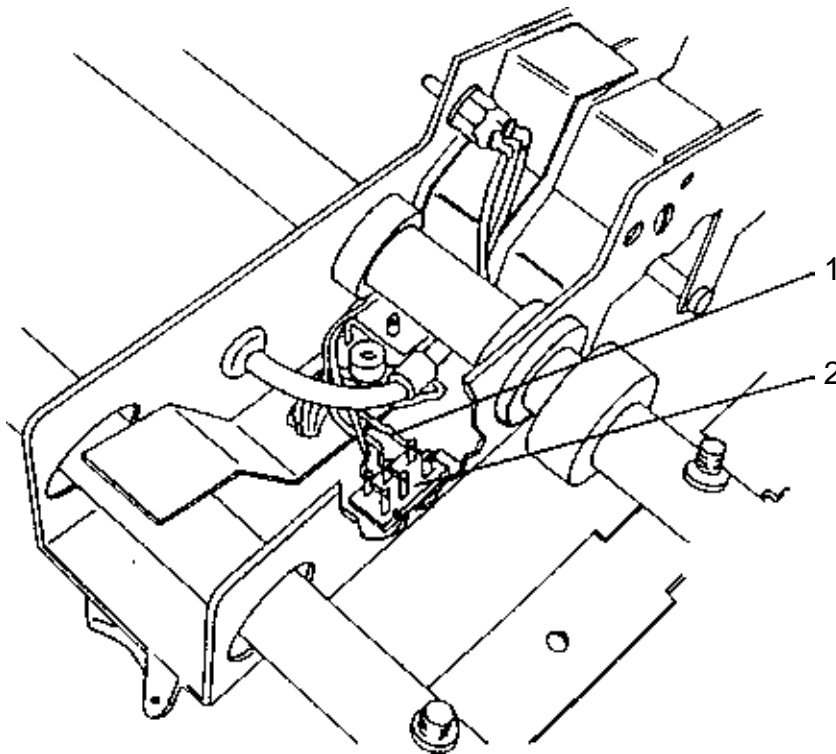
**INSTALLATION**

1. Solder wires onto switch.
2. Fit stapler bracket into place.

REMOVAL

1. Switch off the main power switch and disconnect the power cord.
2. Open the top cover.
3. Cut the cable-tie (1) next to the interlock switch.
4. Loosen the two screws (2) and lift out the switches fitted into keyholes.

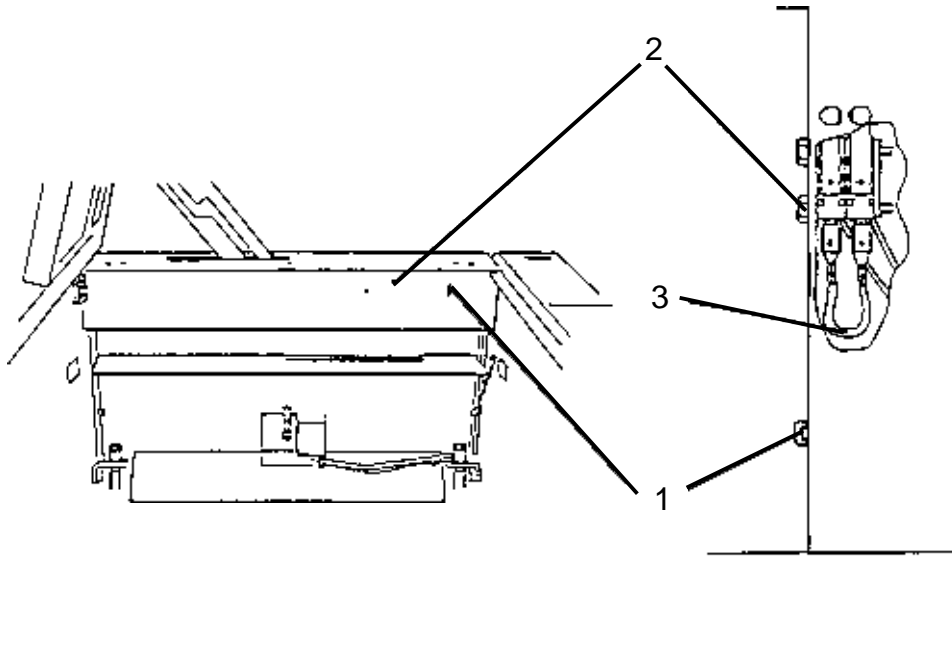

INSTALLATION

1. Connect jumper (3) to the middle pin of each switch.
2. Connect the black and white wire to the lower pin of each switch.
3. Mount the interlock switches into the keyholes and tighten the screws (2).
4. Remove rear cover according to REP 1.1.
5. Check the interlock function by measuring resistance between J1-18C and common ground.

NOTE: Make sure the service switch is not pulled out when checking the interlock switches.

CAUTION: Main power should be switched off when checking the interlock switches.

There should be less than 0.5 ohms with the top cover closed.

There should be no contact (infinite resistance) when top cover is open.

REMOVAL

1. Switch off the main power switch and disconnect the power cord.
2. Remove rear cover according to REP 1.1.
3. Remove the two screws (1).
4. Note the position of the wires and disconnect and remove the switch.

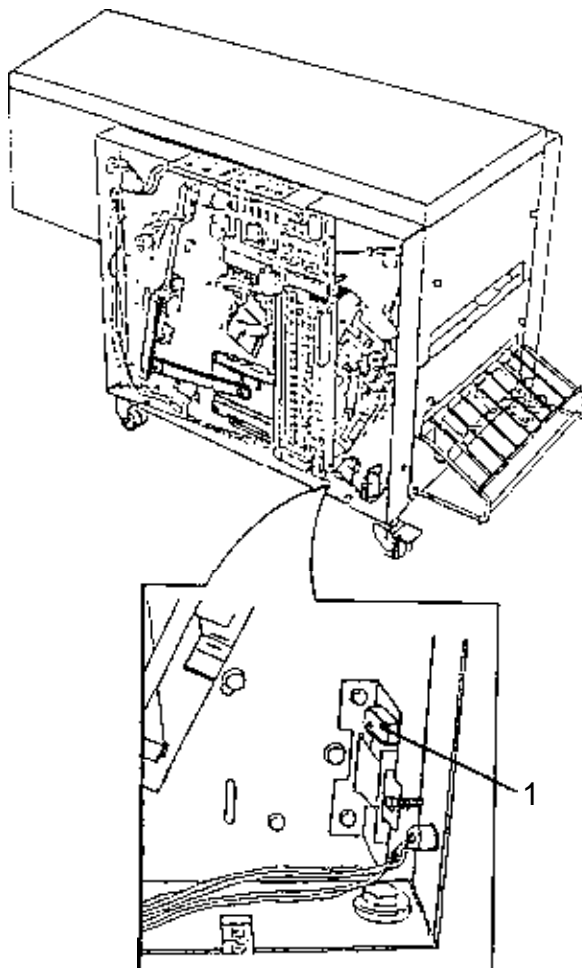

INSTALLATION

Installation is an exact reversed procedure of removal.

PURPOSE

To ensure the transport of the set from stapling to folding area by providing adequate eject drive pressure.

REMOVAL.

1. Remove the infeed module according to REP 2.1.
2. Remove the front cover according to REP 1.1.
3. Loosen the four screws (1).
Push down motor bracket (2).
Slide the registration carriage to the left (towards the outfeed area).
4. Remove the deck plate according to REP 1.3.
5. Disconnect the spring (3).
6. Note the position of the wires at the rear of the solenoid.
7. **CAUTION: Hold the solenoid body while removing the last screw.**
7. Remove the four screws holding the solenoid to the bracket.

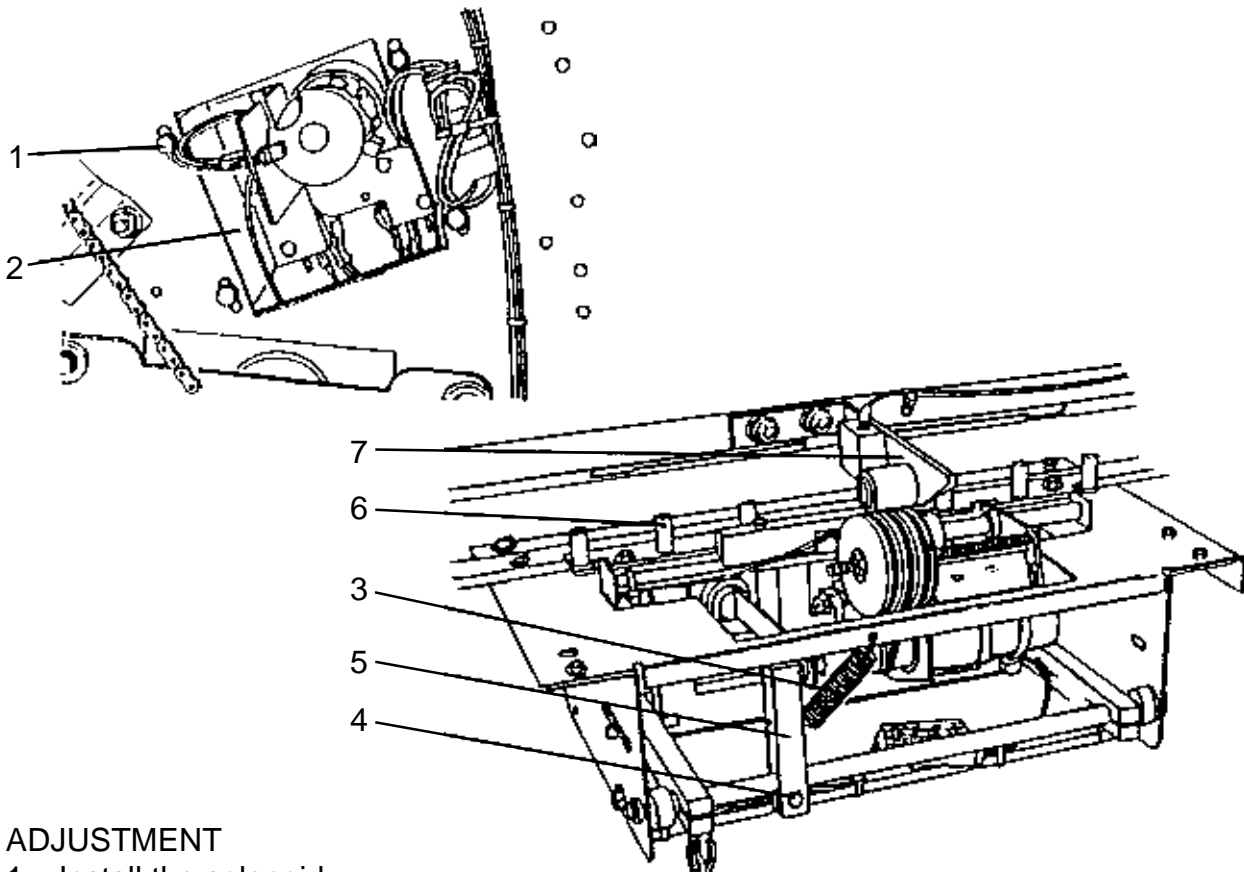

ADJUSTMENT

1. Install the solenoid.
2. Loosen screw (4) so the linkage (5) can move.
3. Use a 2mm feeler gauge or spacer between plunger washer and solenoid body.
4. Push down stop gate (6) completely and move linkage until O-rings touch the idler roller.
5. Tighten the screw (4).
6. Install the spring (3).
7. Check for 0.5-1.5mm idler arm (7) deflection when solenoid is energized.
See FIP 10.1 how to energize the solenoid or push on the solenoid plunger.

REMOVAL.

1. On the control panel, adjust the machine into A4 (8.5x11") position and then adjust the side guides to the widest position.
2. Switch off the main power switch and disconnect the power cord.
3. Remove the in feed module according to REP 2.1.
4. Disconnect the drive O-ring.

Model 88

5. Loosen the four nuts holding infeed paper path.
6. Carefully lift out paper path.
7. Disconnect spring (1) and transfer leads (2) to new solenoid.
8. Remove old solenoid by removing the two screws (3).

Model 102

5. Remove the four small shafts that the infeed belt is routed around.
6. Loosen the four nuts holding bracket for the whole carriage assembly.
7. Carefully pull out the whole assembly.
8. Remove the screw securing plunger to back jogger.
9. Disconnect spring (1) and transfer leads (2) to new solenoid.
10. Remove old solenoid by removing the two screws (3).

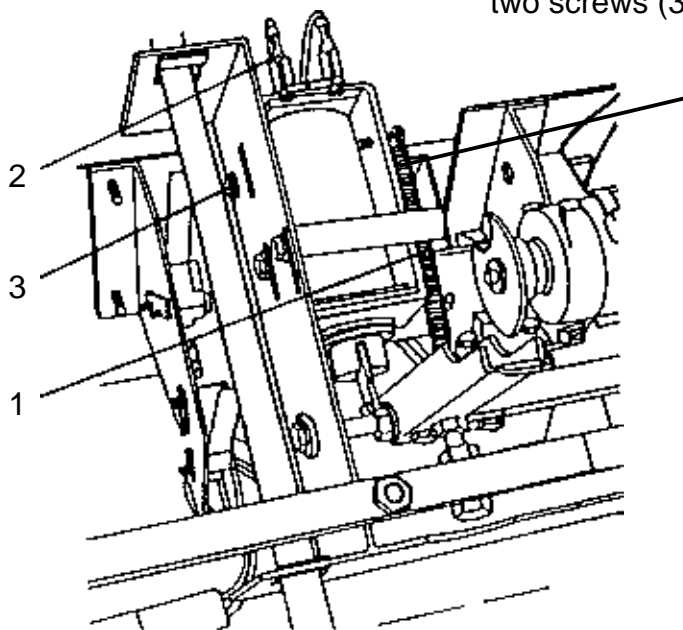

NOTE: The spring is attached across the solenoid on Model 102

INSTALLATION

Installation is an exact reversed procedure of removal.

ADJUSTMENT

1. Ensure the back jogger is against the stop.
For Model 102, place the shaft with the stop in position and ensure the back jogger is against that stop.
2. Adjust solenoid body until there is 1-2mm clearance between body and plunger washer, by loosen/tighten screws (3).

REMOVAL

1. Switch off the main power and disconnect the power cord.
2. Remove the front cover according to REP 1.1.

Solenoid

3. Note the position of the wires and disconnect the plugs from the solenoid (5)
4. Remove the two screws (4) to remove solenoid (5).

Switch

3. Note the position of the wires and disconnect the plugs from the switch (3).
4. Remove the two screws (6) to remove switch (3).

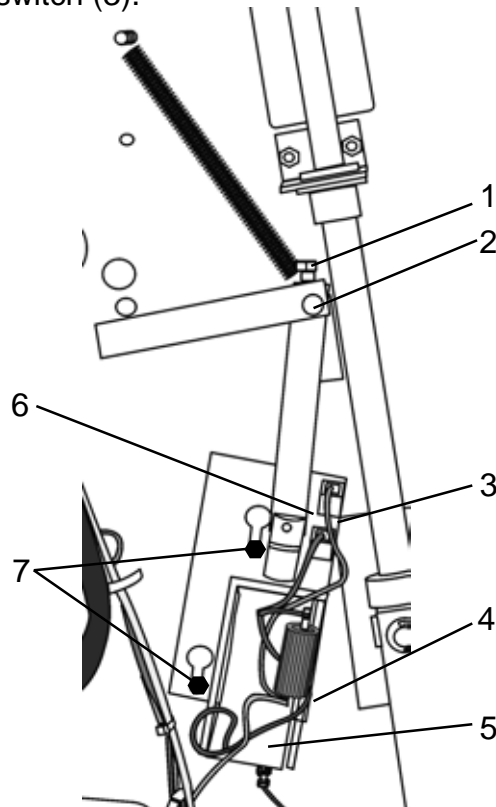
**INSTALLATION**

Installation is an exact reversed procedure of removal.

ADJUSTMENT**Edge staple stop height**

1. Open the top cover.
2. Move stapler assemblies fully apart.
3. Make sure the stop finger height is even on both sides. Use the clincher housing as reference while moving stop finger linkage up/down.
4. Loosen screw (1) on front and/or rear side and level shaft (2) until even height is obtained.
5. Push down the plunger to the bottom position.
6. Make sure the stop fingers are about 1mm below the top surface of the clincher housing.
7. Loosen screws (7) and move solenoid to obtain measurement.

Switch position

1. Adjust the switch (3) so it activates when there is 1-2mm between solenoid body and plunger washer.

REMOVAL

1. Remove the infeed idler arm assembly according to REP 2.2.
2. Remove the solenoid (1) by removing the screws (2).

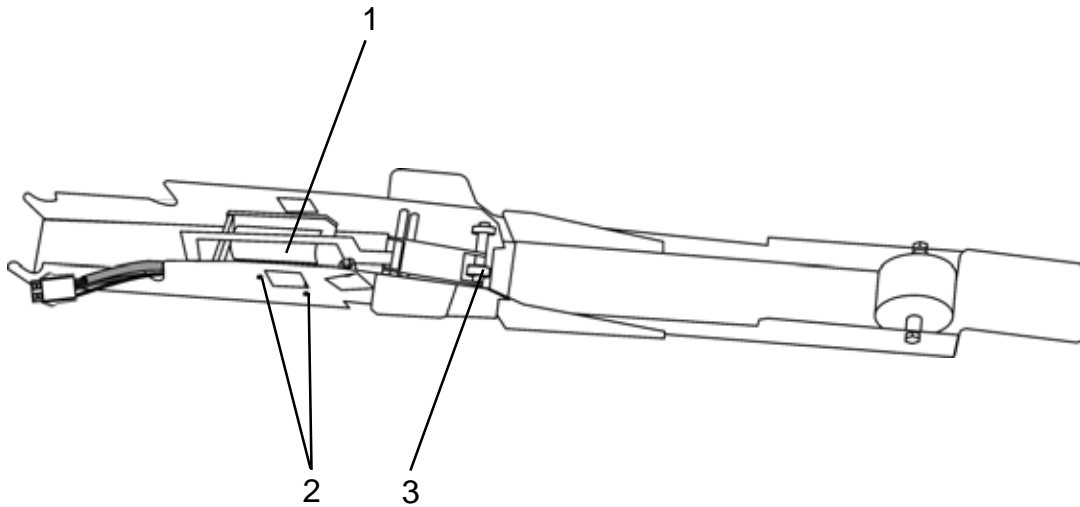
**INSTALLATION / ADJUSTMENT**

1. Mount the solenoid and fasten the screws (2) in the middle of the elongated holes.
2. Mount the idler arm assembly.
3. Make sure there is about 1mm clearance between solenoid body and plunger washer when the idler rollers (3) contacts the infeed belt.
Fine adjust solenoid position with screws (2) if necessary.

REMOVAL

1. Switch off the main power switch and disconnect the power cord.
2. Remove front cover and infeed cover according to REP 1.1.
3. Remove transformer cover.
4. Note the position of wires and disconnect motor leads at terminal block (1).
5. Remove safety guard.
6. Disengage the drive chain (2) from sprocket (3) on motor.
7. Remove the three screws (4) and lift out the motor.
8. Transfer sprocket to new motor.

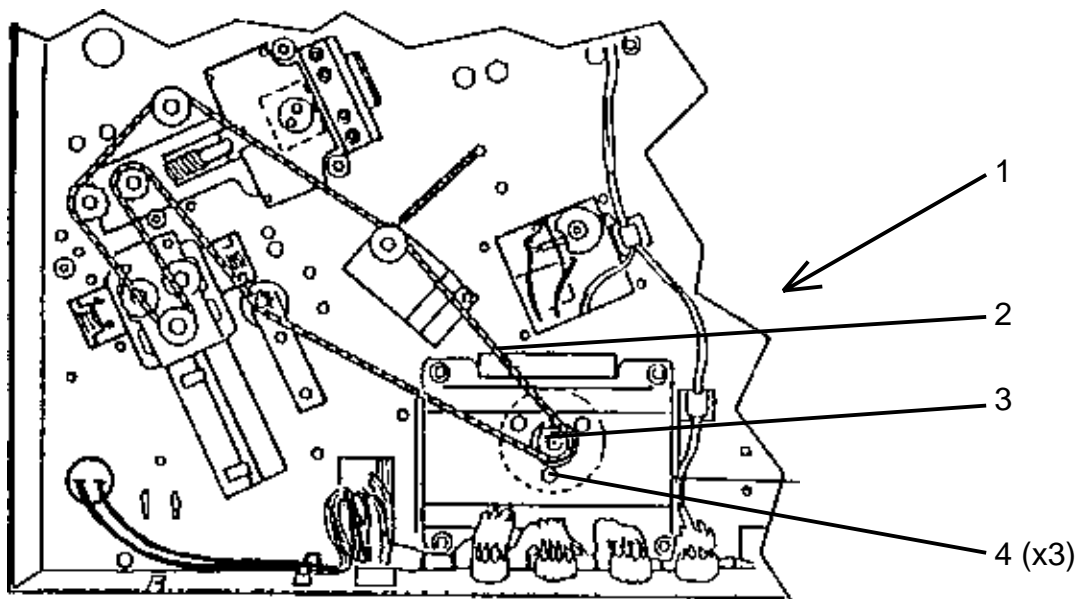

INSTALLATION

Installation is an exact reversed procedure of removal.

REMOVAL

1. Switch off the main power and disconnect the power cord.
2. Remove the front and rear cover according to REP 1.1 and safety guard.
3. Remove the driver PCB.
4. Remove the chain (1).
5. Remove retaining ring (2).
NOTE: Use a screw driver as a lever between spring bracket (2) and bearing bracket to release the spring tension.
6. Remove the tension arm assembly (4).
7. Remove the two chains (6).
8. Remove the two lower sprockets (5).
NOTE. There might be shim washers by the sprockets. Note their position and quantity for installation.

Ball Bearings

9. Remove bearings.

Fold Rollers

9. Open the top cover.
10. Lift up (Remove for Model 88) the guide plate between lower and upper fold rollers.
11. Pull out the fold roller through the inside of the machine.
12. Remove the lower outfeed cover according to REP 1.2.
13. Pull out the other fold roller through the fold area of the machine.

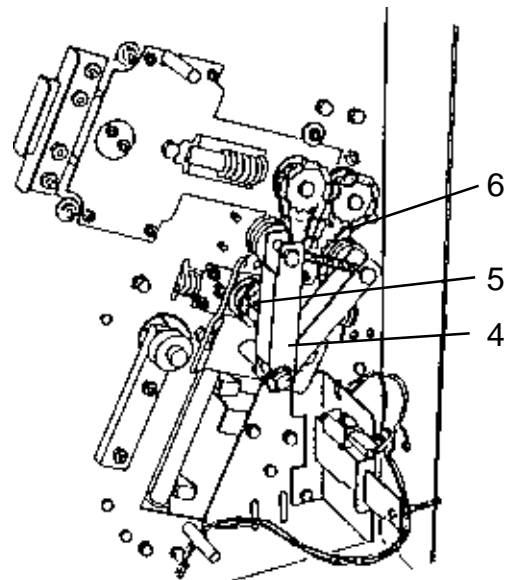
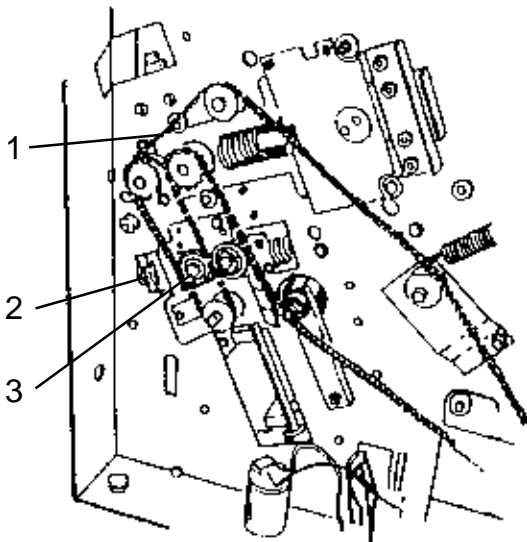

INSTALLATION

Installation is an exact reversed procedure of removal.

REMOVAL

1. Switch off the main power and disconnect the power cord.
2. Remove the front and rear cover according to REP 1.1 and safety guard.
3. Remove the driver PCB.
4. Remove the chain (1).
NOTE: Open the top cover and move the pressure knobs in the different positions to release/unrelease the spring tension.
5. Remove the two upper sprockets (2).
6. Remove the tension arm assembly (3).
7. Remove the two chains (5).
8. Remove the two upper sprockets (4).
NOTE. There might be shim washers by the sprockets. Note their position and quantity for installation.
9. Remove bearings.

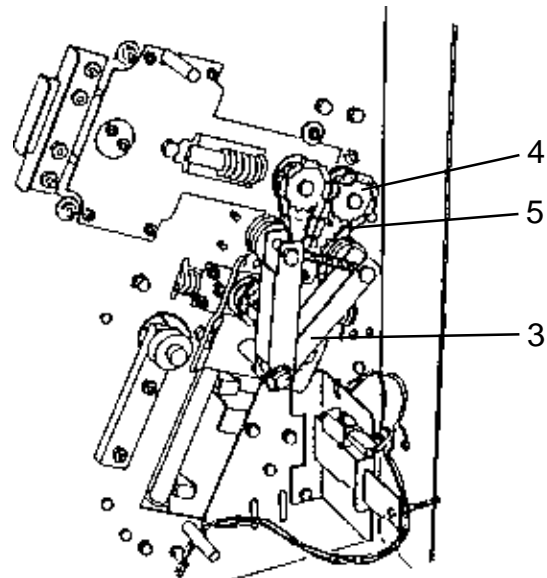
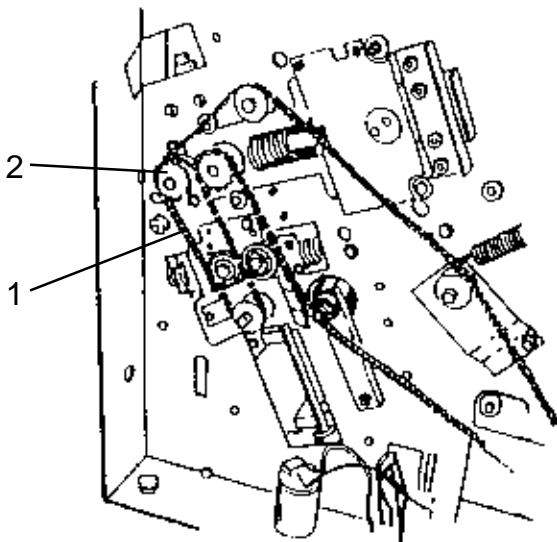

INSTALLATION

Installation is an exact reversed procedure of removal.

REMOVAL

1. Switch off the main power switch and disconnect the power cord.
2. Remove rear cover and infeed cover according to REP 1.1.
3. Remove safety guard.
4. Loosen the three screws (1) and remove chain from sprocket.
5. Remove sprocket from motor.
6. Remove the transformer cover.
7. Note position of the wires and disconnect the motor leads at terminal block.
8. Remove screws(1) and lift out motor.
9. Transfer sprocket to new motor.

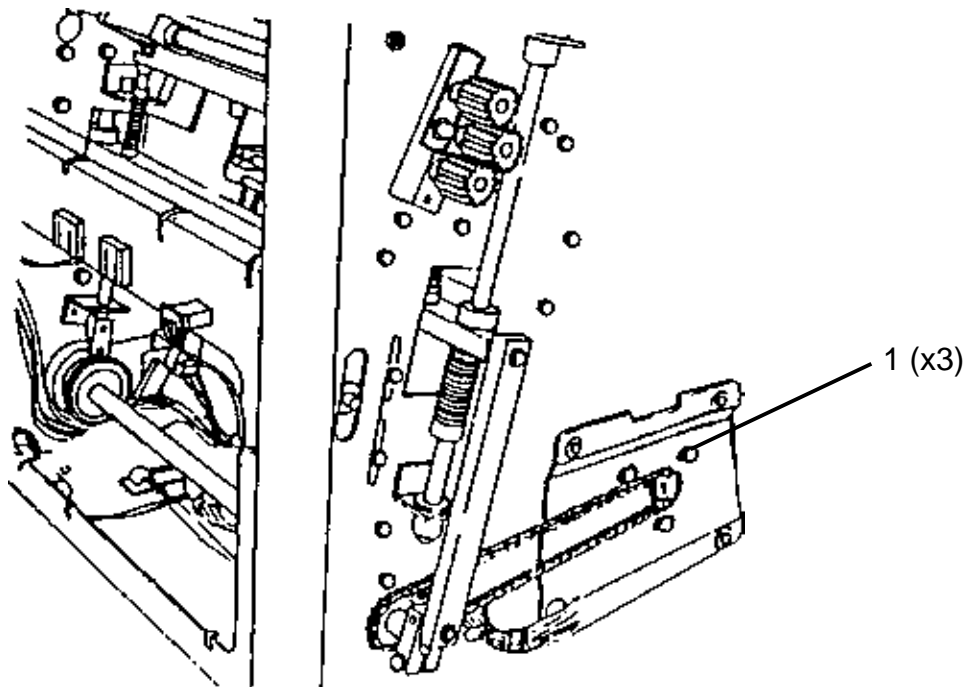
**INSTALLATION**

1. Install the motor in reversed procedure of removal.

ADJUSTMENT

2. Adjust the motor so it is possible to move the chain 4-10 mm up or down when screws are tightened.

REMOVAL

1. From the control panel, select A3/17" size.
2. Switch off the main power and disconnect the power cord.
3. Open the top cover.
4. Loosen the knob and move the stapler assmeby away from the clincher.
5. For Model 88 only: Ensure that the clincher position is marked with a scribed line (1).
6. Remove the two screws (2) while holding the clincher bracket (3).
7. Carefully lift out the bracket (3) with clincher.

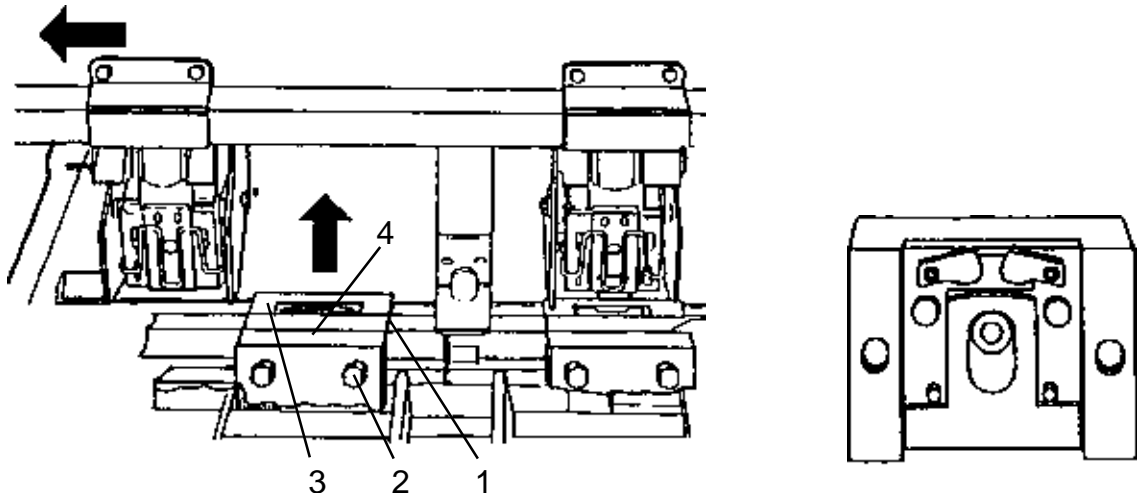

INSTALLATION / ADJUSTMENT

Model 88

5. Install the clincher assembly aligned with the scribe line and top surface of the clincher bracket flush with the top surface of the clincher beam.

Model 102

5. Install the clincher assembly so the top surface of the clincher bracket is flush with the top surface of the clincher beam.
6. Loosen set screw (4).
7. Tighten the screws (3) not harder than making it possible to easilly slide the clincher assembly throughout the width of the clincher beam.
8. Secure the assembly with set screw (4).

MAINTENANCE

1. Remove the retaining plate.
2. Clean the components of the clincher.
3. Check for wear and burrs. If any sign of wear or burrs the clincher assembly must be replaced.
4. Lubricate the components with thin oil.

CAUTION: Do not alter position of the clincher components.

REMOVAL

1. Switch off the main power and disconnect the power cord.
2. Remove the front and rear cover according to REP 1.1 and safety guard.
3. Remove the infeed module according to REP 2.1.

ADJUSTMENT

1. Position the push rod (1) on top of the clincher cam lobe (2).
2. Make sure that crank elbow (4) and link arm (3) is in position as shown in figure on both sides.
3. Adjust angle of crank elbow (4) if necessary.

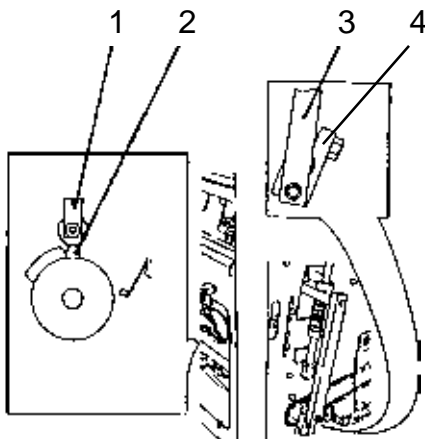

4. With the push rod on cam lobe:
Check that clincher fingers are flush with the top surface of the clincher bracket within 0.1mm.
5. Adjust the flushness by adjusting nuts (5).

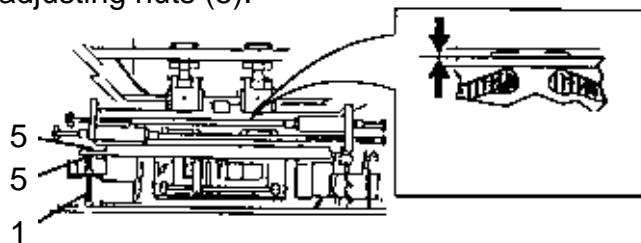

6. With the link arm in home position (9):
Check that the switch actuator (6) is near the center of the switch cam lobe (7).
7. Adjust by loosening the screws (8) and turn the cam lobe (7) to correct position.

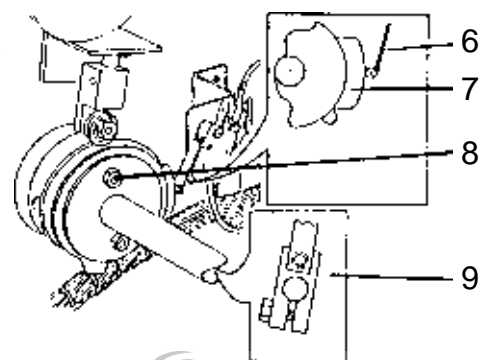

PURPOSE

The spring stop, stops the movement smoothly before the stop position for the stapler head. If not correctly adjusted, the stapler head can wear out premature causing the plastic post on the stapler head to break. This adjustment is in relation to the stapler retraction lift bracket. If the lift bracket is deformed it causes the same symptom. The lift bracket can be deformed if stapler head once has been installed incorrectly. Replace lift bracket if deformed before proceeding with this adjustment.

ADJUSTMENT

1. Open the top cover.
2. Make sure the stapler heads are properly installed.
3. Check with a feeler gauge in the cut through the elongated hole (1).
The clearance should read 0.5-0.7mm.

**NOTE: The elongated hole is smaller than standard feeler gauges.
The feeler gauge may need to be modified.**

4. Adjust on the nut (2) to obtain measurement.

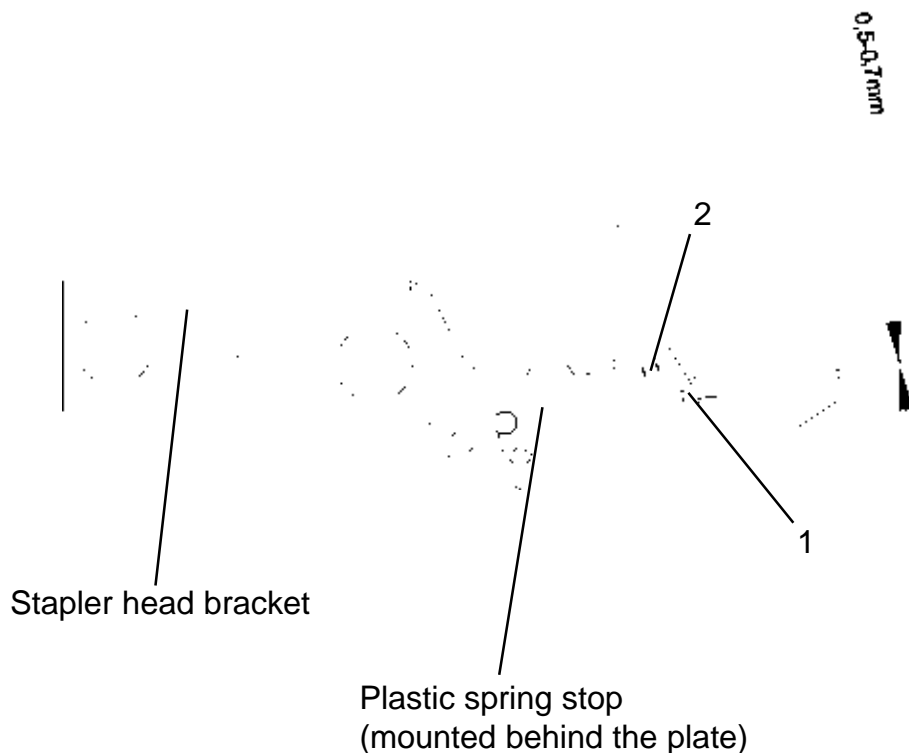

REMOVAL.

1. Switch off the main power switch and disconnect the power cord.
2. Remove front, rear and infeed cover according to REP 1.1.
3. Remove PCB drive board according to REP 7.2.
4. Move the fold roller motor (REP 5.1) to allow tilting the fold knife motor bracket. Do not disconnect the leads, just move the motor towards the in feed side.
5. Locate the four bracket screws (1 and 2) outside of the side frames.
6. Remove the three upper screws (1) and loosen the lower (2) on front and rear side.
7. From the inside, remove screws securing motor bracket (3) to the frame bracket.
8. Note position of wires, disconnect motor leads and lift out motor and Cam assembly.
9. Loosen the clamp (4) and remove the Cam (5).
10. Remove motor from bracket.

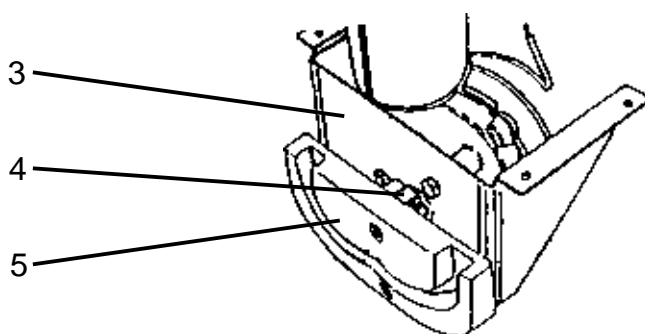
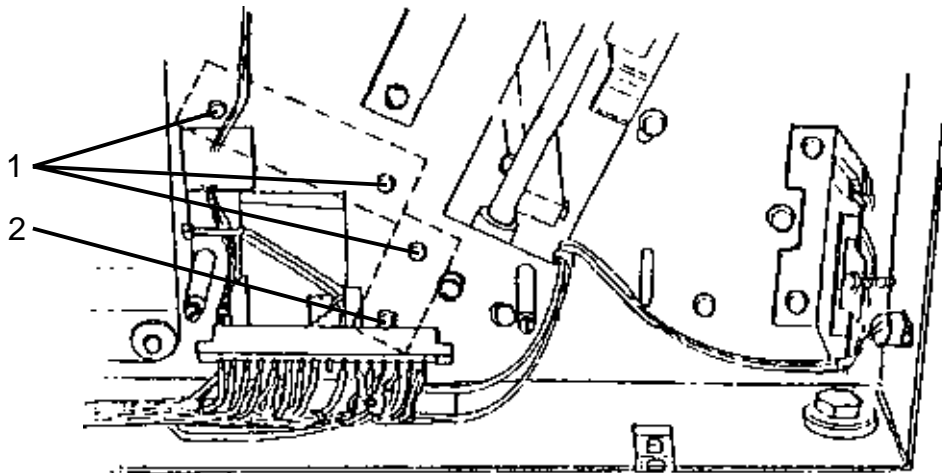
**INSTALLATION**

1. Install the motor in reversed procedure of removal.
2. Ensure that the fold knife cam follower, situated on the fold knife, is seated in the cam (5).

REMOVAL.

1. Remove the infeed module according to REP 2.1.
2. Disconnect spring (1)
Cut cable-tie and disconnect the plug (2).
3. Disconnect the drive O-ring (3).
4. Loosen the lower two screws (5) holding the motor.
Rotate motor CCW and lift out motor (4) with pulley, fitted into keyholes.

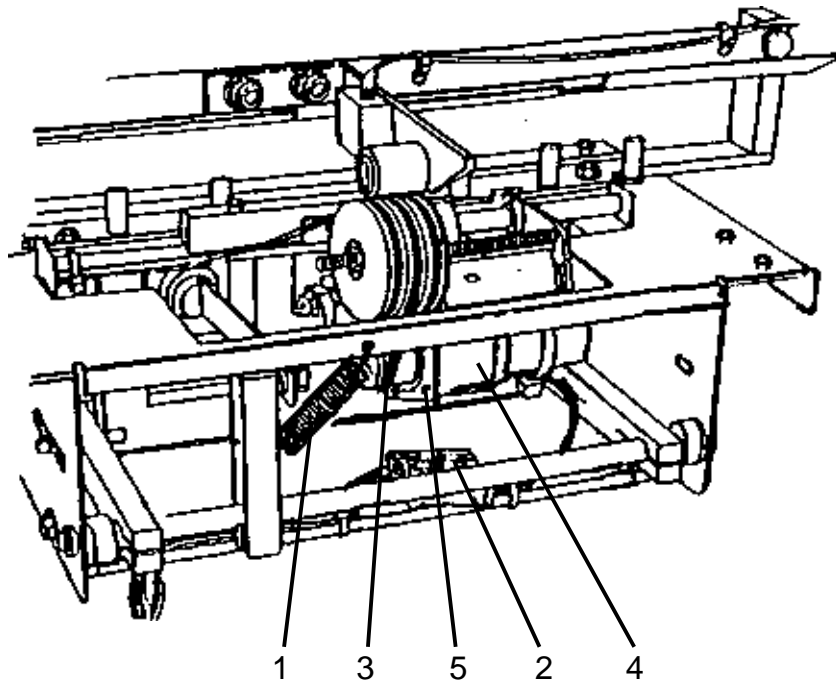

INSTALLATION

Installation is an exact reversed procedure of removal.

CAUTION: Replace the drive O-ring if slightest evidence of wear or loss of friction. The O-ring is a wear-out part. If the O-ring is worn thicker sets will not be ejected from the staple area.

REMOVAL

1. Switch off the main power switch and disconnect the power cord.
2. Remove rear and infeed cover according to REP 1.1.
3. Disconnect the plug (1) from frame.
4. Remove the switch bracket by removing the two screws(2).
5. Raise the cam follower by tilting the plastic upper rocker arm of the assembly away from side frame.

NOTE: Use a screwdriver to block tilt arm in this position as shown in figure.

6. Loosen the set screws (3) in cam holder and remove cam assembly.
7. Remove motor by removing the four screws.

CAUTION: Do not allow motor to fall into machine. Hold motor while removing last screws.

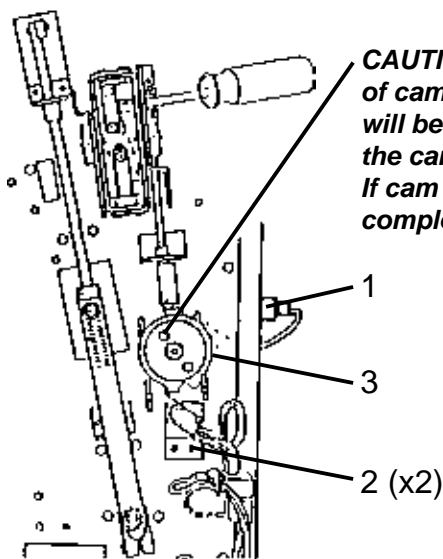

CAUTION: Do not loosen the two screws in face plate of cam assembly, otherwise cam timing relationship will be lost. Loosen only the set screws (3) securing the cam assembly to motor shaft. If cam assembly has been tampered with replace the complete cam assembly.

INSTALLATION

1. Mount the motor in the top position of the elongated holes.
2. Check the side jogger push rod centering according to REP 5.12.

REMOVAL

1. Switch off the main power and disconnect the power cord.
2. Remove the rear cover according to REP 1.1.
3. Remove the infeed module according to REP 2.1.

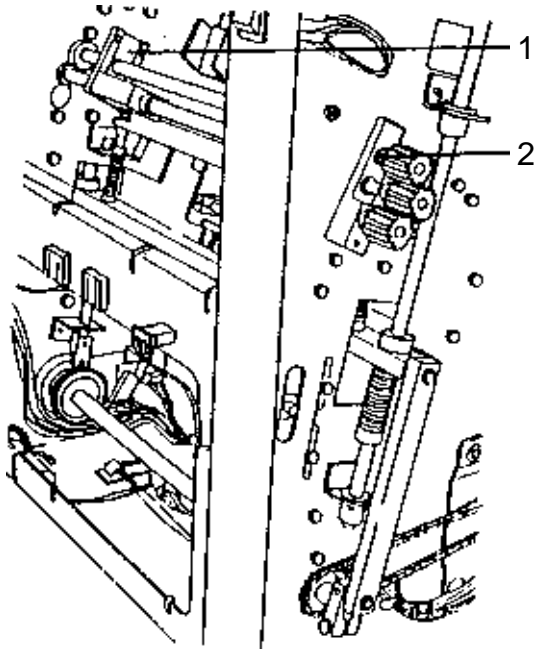

ADJUSTMENT

1. Measure the distance between side jogger bearing plate (1) to side frame on both sides. The difference should be less than 1mm.
2. Loosen the gear by loosening set screw (2).
3. Rotate shaft to obtain measurement.
4. Tighten the set screw.
5. Follow the adjustment of the side jogger home position switch according to REP 3.8.

REMOVAL

1. From the control panel, select A3/17" size.
2. Switch off the main power and disconnect the power cord.
3. Remove the front cover according to REP 1.1.

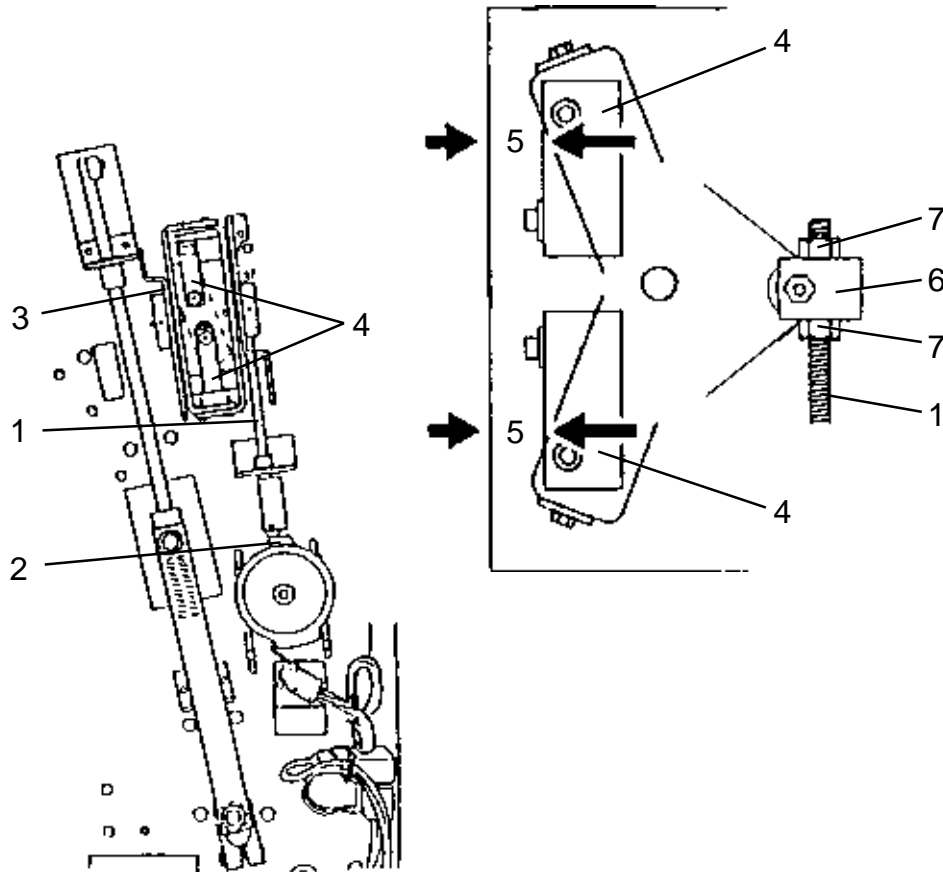

ADJUSTMENT

1. With the pushrod (1) on the cam lobe (2):
Measure the distance (5) from upper rocker arm (4) to edge of bracket (3).
2. Turn the pushrod (1) off the cam lobe (2):
Measure the distance (5) from lower rocker arm (4) to edge of bracket (3).
3. The difference between two measurements should not exceed 2mm.
4. Adjust the push rod block (6) by adjusting nuts (7) to obtain equal distance within 2mm.
5. Follow the adjustment of the side jogger home position switch according to REP 3.8.

REMOVAL

1. Switch off the main power switch and disconnect the power cord.
2. Remove infeed cover according to REP 1.1.
3. Remove drive O-ring (1)
4. Remove the tension adjustment nuts and washers (2), while holding the motor.
5. Lift out motor and bracket (3).
6. Note the positions and disconnect wires at terminal block (4).
7. Remove motor from bracket.

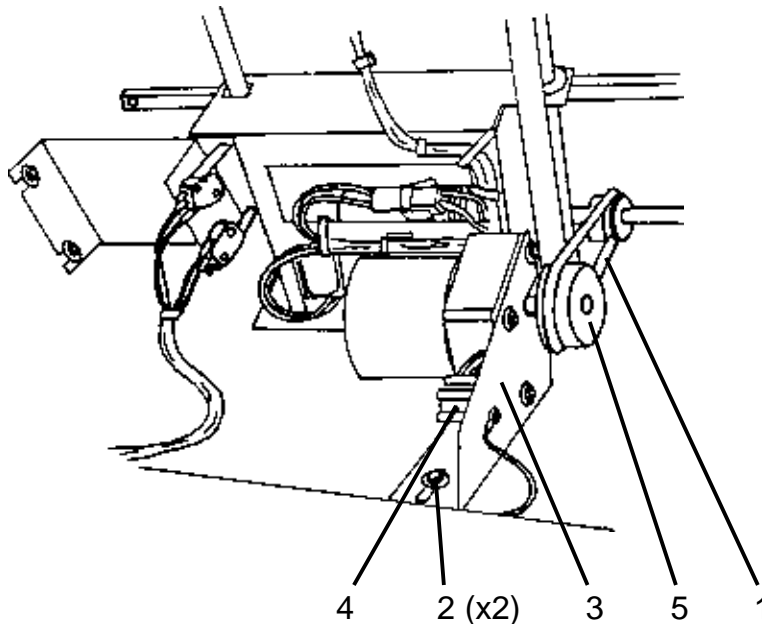
**INSTALLATION**

1. Transfer pulley (5) to new motor.
2. Mount the pulley so the O-ring is aligned to the runner pulley. Use the smaller diameter of the pulley.
3. Tension drive O-ring and tighten adjustment nuts. Ensure correct tension of the drive O-ring.

NOTE: The infeed belt motor usually wears out too soon because the machine is left in manual mode (where the motor continuously run).

Instruct the operator to press Auto (switching off the motor) on the front panel when not hand feeding.

REMOVAL

1. From the control panel, select A3/17" size.
2. Switch off the main power and disconnect the power cord.
3. Fold down the fold stop gate (5).
4. Remove screws (1) to remove motor assembly.
5. From PCB plug J3; remove white wire at pin 9 and blue wire at pin 10.
6. Note how the wires are routed and cut cable-tie to remove wires from the harness.
7. Remove crank elbow (3) from the motor.
8. Remove the three screws holding the motor (4) to the motor bracket.

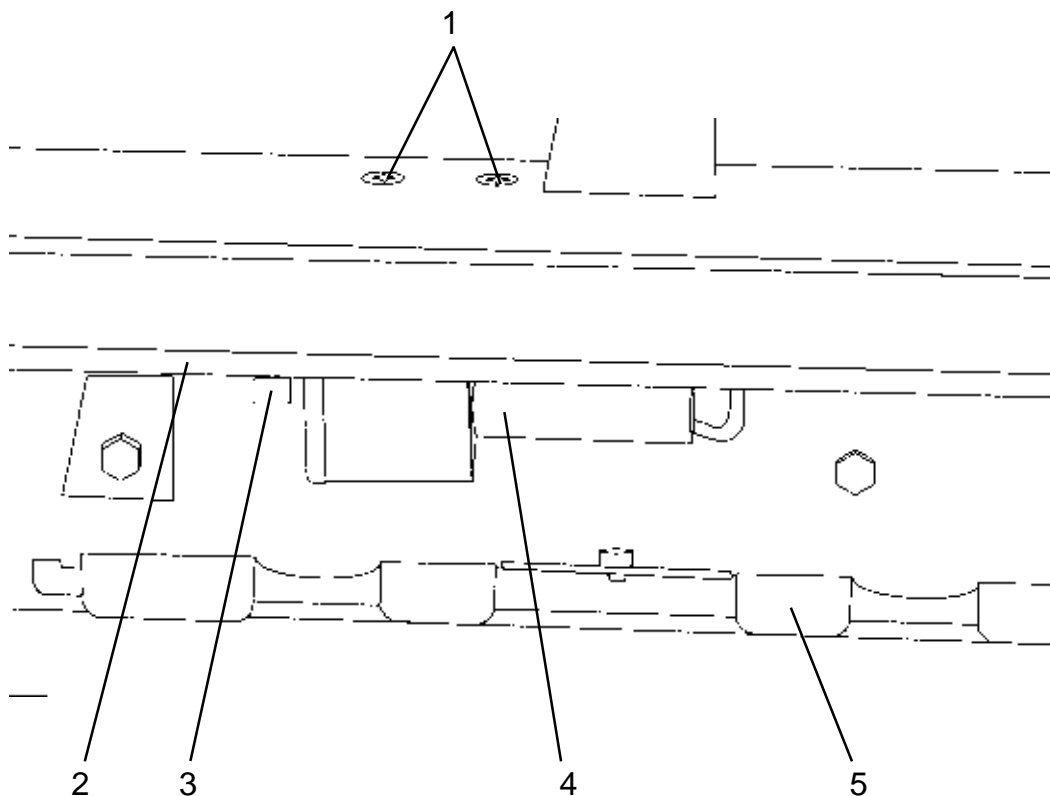

INSTALLATION

1. Make sure the crank elbow (3) is hooked on to the shaft (2) before tightening screws (1).
CAUTION: Go from smallest to largest paper size and make sure the wires do not get stretched or interfere with moving parts.

REMOVAL

1. Switch off the main power and disconnect the power cord.
2. Remove the front and infeed cover according to REP 1.1.
Remove safety guard.
CAUTION: When loosening the screws the registration carriage comes loose and will slide towards the outfeed. If sliding uncontrolled it could damage the limit and home position switch. If damaged see REP 3.13.
3. Loosen the four screws (1) and slide the registration carriage towards the output area.
4. Disconnect the motor wires at the connector (2).
5. Hold the bracket and remove screws (1).
CAUTION: Do not allow motor to fall into machine. Hold motor while removing the last screw. Avoid damaging the SOS sensor when removing motor from bracket.
6. Remove the gear (3) and remove motor from bracket.

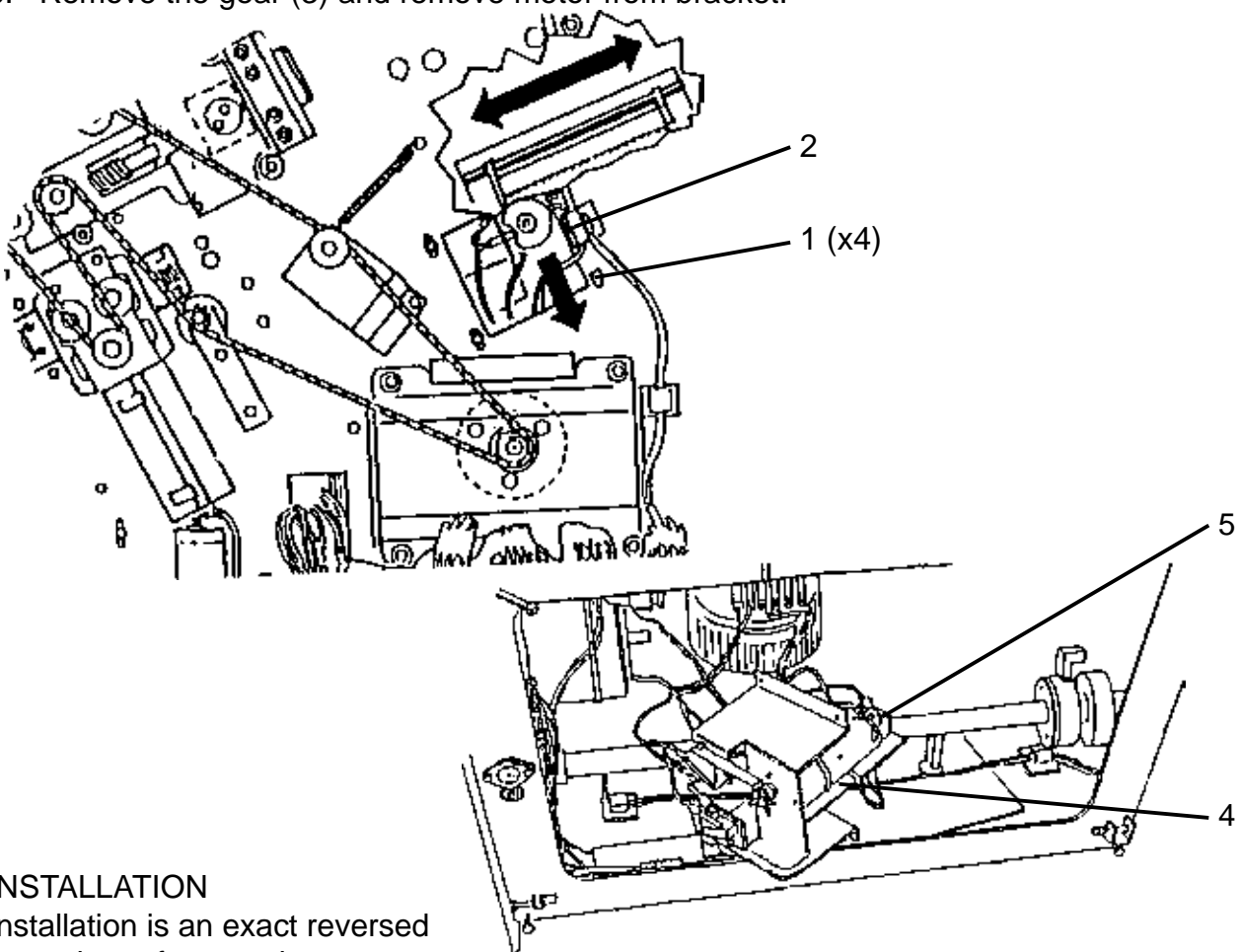

INSTALLATION

Installation is an exact reversed procedure of removal.

ADJUSTMENT

1. When motor is installed in bracket, install gear 5.5 mm from end of shaft as show in figure.
2. Before tightening the screws (1);
move carriage slightly towards the infeed,
push bracket up to engage the gear with gear rack,
do not push up so hard that the gear rack becomes bent.
3. Adjust sensor bracket (4) so there is a 2 mm gap between bottom of sensor and disc (5) at rear end of motor.

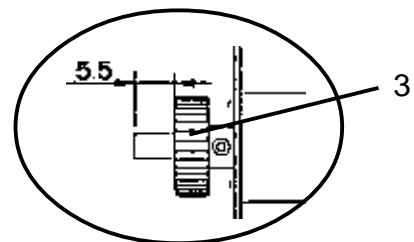

PROCEDURE

1. Set the machine up for A3 (11"x17").
NOTE: When the adjustments are completed, double check that the output quality remains for A4 (8.5"x 11") paper size. If not the fold stop gate could be uneven.
2. On the control panel, select manual mode [MAN].

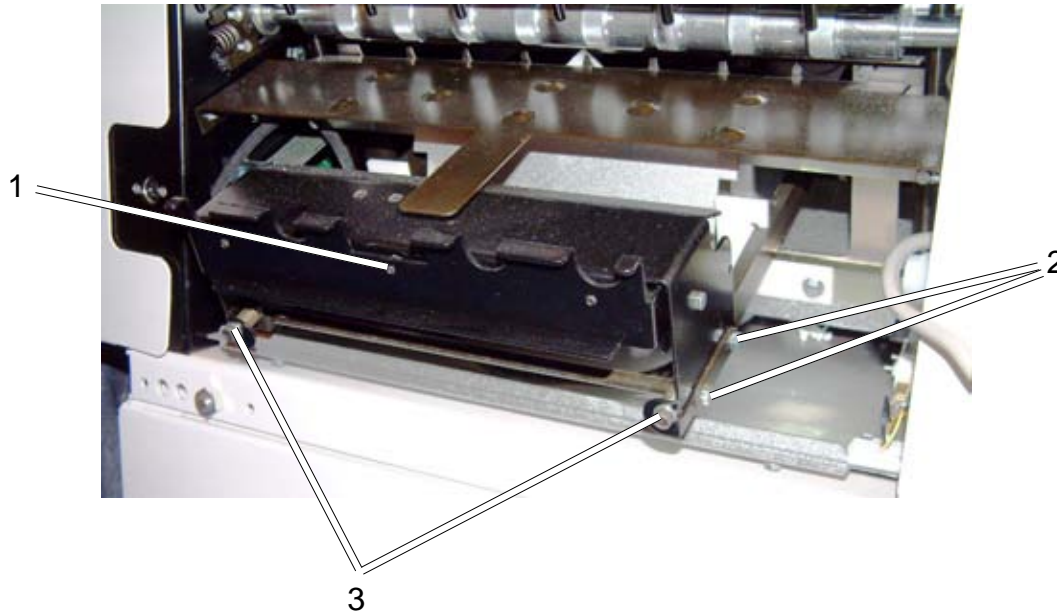

ADJUSTMENT

NOTE: Before initiating the adjustment, make sure the paper is perfectly square (90°) and the opposite edges are the exact same length.

Skew fold

1. Run a few sets.
2. Check that the fold is parallel to the lead edge of the set. If not perform Adjustment 1.
3. Place the stacker module in upright position (if a trimmer is installed, remove trimmer).
4. Switch off the main power switch and disconnect the power cord.
5. Loosen the two mounting screws (2) on one side.
6. Rotate the adjustment screw (3) on the same side to adjust.
7. Tighten the two mounting screws (2).
8. Repeat this adjustment until the fold is parallel to the edge of the set.

Staples not centered in spine

1. Run a few sets.
2. Check that the staples are in the middle of the fold.
3. Loosen the locknut (1)
4. Rotate the setscrew (1) clockwise if the staples are located on the top. Rotate the setscrew (1) counterclockwise if the staples are located on the bottom.
NOTE: Top of the booklet is the side that contacts the output wheel.
5. Tighten the locknut.
6. Repeat this adjustment until the staples are aligned with the fold.

REMOVAL.

1. On the control panel, adjust the machine into A4 (8.5x11") position and then adjust the side guides to the widest position.
2. Switch off the main power switch and disconnect the power cord.
3. Remove the in feed module according to REP 2.1.
4. Disconnect the drive O-ring.

Model 88

5. Loosen the four nuts holding infeed paper path.
6. Carefully lift out paper path.
7. Note position of connector, remove cable-tie (1) and disconnect plug (2).
8. Remove the three screws holding adjustment motor to carrier lift out motor.

Model 102

5. Remove the four small shafts that the infeed belt is routed around.
6. Loosen the four nuts holding bracket (3).
7. Carefully pull out the whole assembly.
8. Note position of connector, remove tie-wrap (1) and disconnect plug (2).
9. Remove the three screws holding adjustment motor to carrier lift out motor.

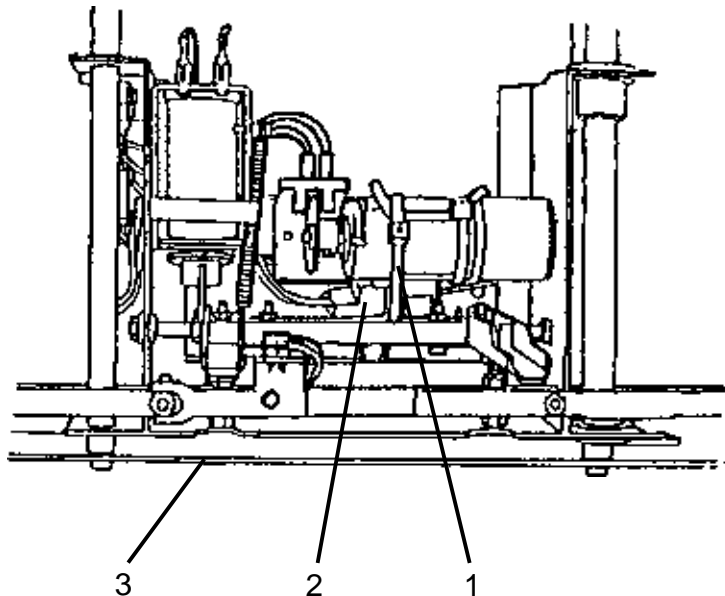
**INSTALLATION**

1. Transfer disc assy and gear to new motor. Center the disc on motor shaft in sensor opening.

ADJUSTMENT

2. Fit screws through carrier into motor housing.
3. Move carrier to enable gear to fit into gear rack, before tightening screws. Ensure correct fitting of gear on adjustment motor into rack.

REMOVAL

1. Switch off the main power and disconnect the power cord.
2. Remove front cover and infeed cover according to REP 1.1.
3. Disconnect the plug (1).
4. Loosen screw (2) two revolutions and remove sensor bracket (3). Note position of connectors or make sure that wire connectors stays on sensor pins.
5. Remove screws (4) from front frame and remove motor.
CAUTION: Do not allow motor to fall into the machine.

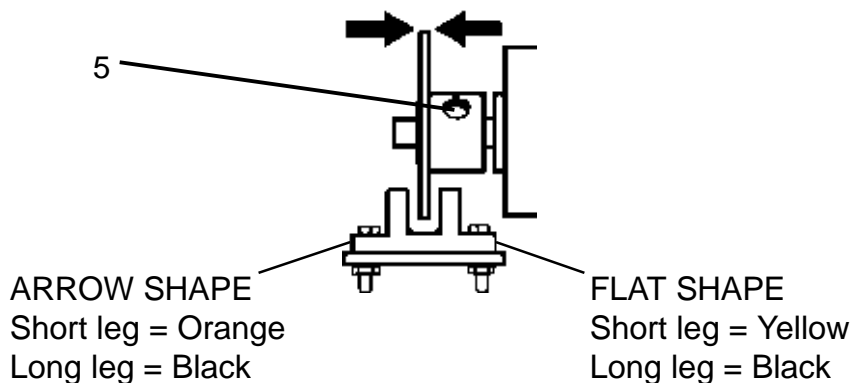
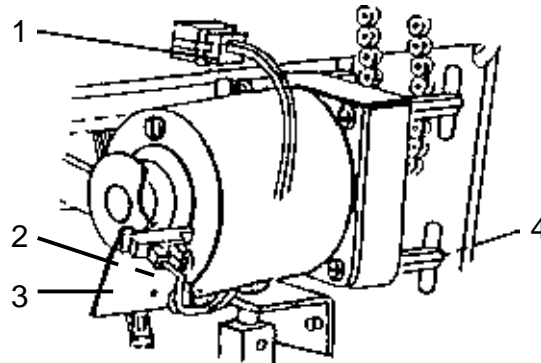

INSTALLATION

1. Transfer components from old to new motor as required.
2. Center the disc on motor shaft in sensor opening.
Loosen set screws (5) and move disc if necessary.
CAUTION: Ensure that the disc does not touch the sensor side.
3. Adjust sensor bracket (REP 3.1)

ADJUSTMENT

4. Allow the motor to be hanging in the chain before tightening the screws (4), to get correct chain tension.

REMOVAL.

1. On the control panel, adjust the machine into A4 (8.5x11") position and then adjust the side guides to the widest position.
2. Switch off the main power switch and disconnect the power cord.
3. Remove the infeed module according to REP 2.1.
4. Disconnect the drive O-ring.

Model 88

5. Loosen the four nuts holding infeed paper path.
6. Carefully lift out paper path.
7. Remove the bracket to infeed idler rod, turn paper path over and remove bracket to infeed bearing (1) on front side.
8. Remove O-ring.

Model 102

5. From the top of the paper path; remove the two screws holding bracket (1).
6. Tilt the infeed shaft and remove O-ring.

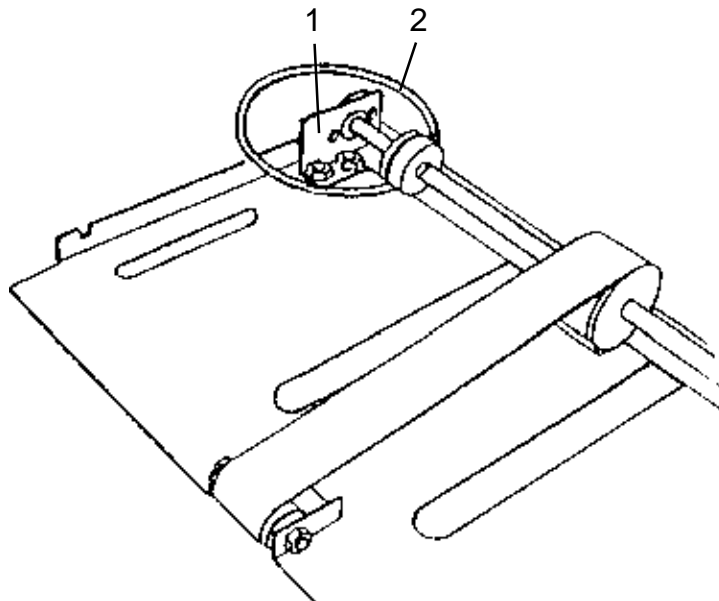

INSTALLATION

Installation is an exact reversed procedure of removal.

REMOVAL.

1. On the control panel, adjust the machine into A4 (8.5x11") position and then adjust the side guides to the widest position.
2. Switch off the main power switch and disconnect the power cord.
3. Remove the infeed module according to REP 2.1.
4. Disconnect the drive O-ring.

Model 88

5. Loosen the four nuts holding infeed paper path.
6. Carefully lift out paper path.
7. Push/pull the belt off the pulley (1) and remove the infeed belt (2).

Model 102

5. Remove the four small shafts that the infeed belt is routed around.
6. From the top of the paper path; remove the two screws holding bracket (3).
7. Tilt the infeed shaft and remove the Infeed belt (2).

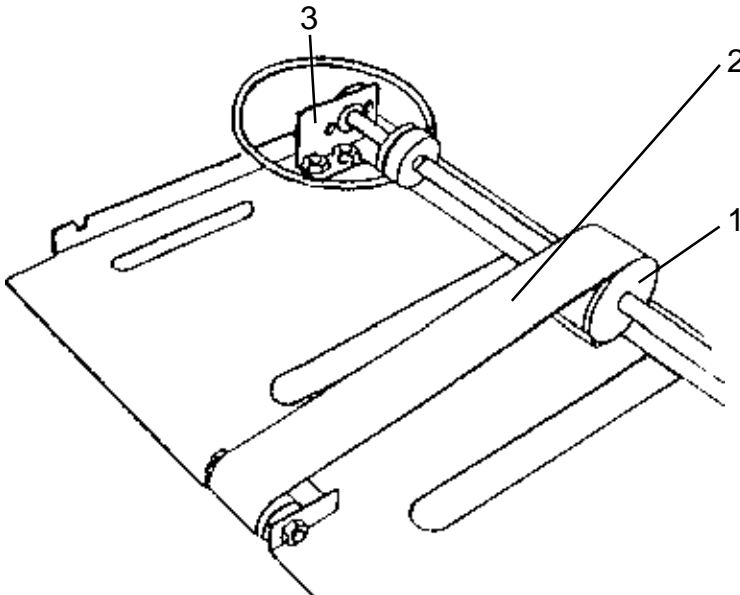
**INSTALLATION**

Installation is an exact reversed procedure of removal.

REMOVAL

1. Switch off the main power and disconnect the power cord.
2. Remove the front and rear cover according to REP 1.1 and safety guard.
3. Remove the infeed module according to REP 2.1.
4. Remove the driver PCB.
5. Mark the position of bracket (1).
- Remove collar (2) and washer by loosening set screw.
6. Remove bracket (1) by removing the two screws (3).
7. Move ball cage (5) off the belts (also spring (4) on Model 88).
8. Remove the belts (6) as shown in the figure.
- Roll the belts up around the shaft.
- Remove belts through opening in the side frame (7).

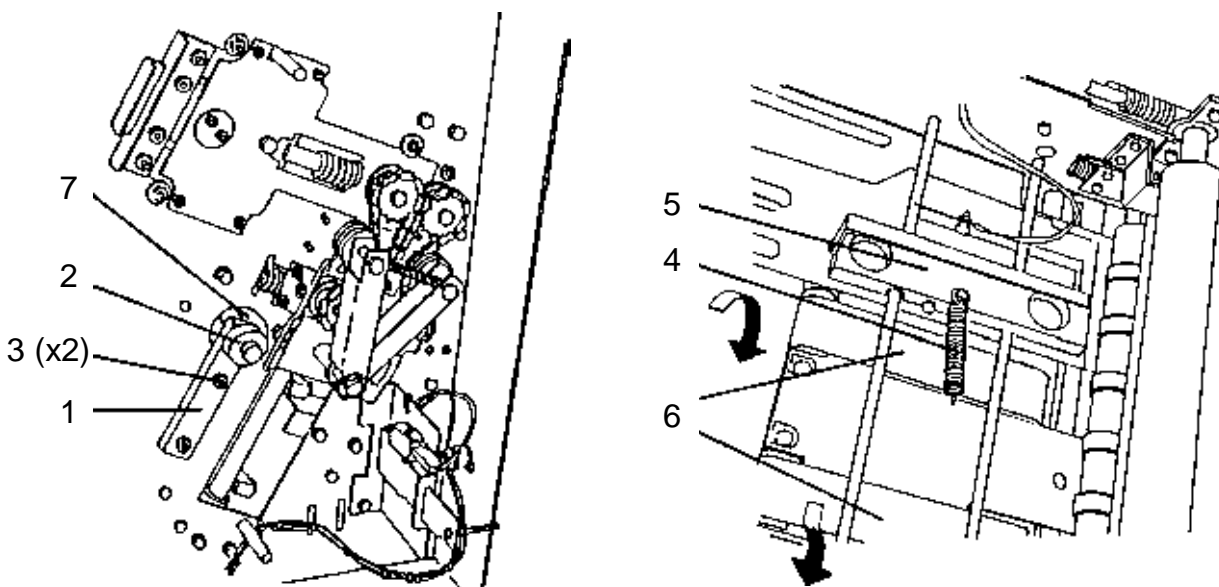

INSTALLATION

1. Install the belts with the black side out.
 2. Make sure the tension is equal on both transport belts.
Adjust bracket (1) to obtain equal tension.
- CAUTION:** *If the belts have become stiff it is very likely that the drive sprocket also has been worn/damaged. In that case also replace sprocket.*

CAUTION: Handle the logic PCB according to Electrostatic Discharge (ESD) procedures. The logic board contains components that are susceptible to ESD damage.

NOTE: By replacing the Logic board all factory set paper sizes will be lost and must be reprogrammed.

REMOVAL

1. Switch off the main power switch and disconnect the power cord.
2. Remove rear cover according to REP 1.1.
3. Disconnect the plugs (1).
4. Remove the four screws (2) and carefully lift PCB to disengage from motor drive board.

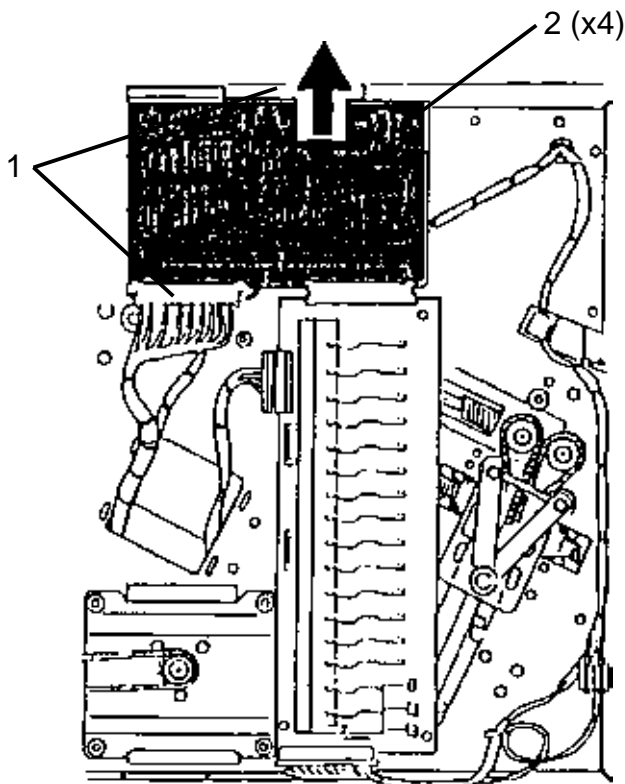

INSTALLATION

1. Install the board in reversed procedure of removal.
2. The Logic board is delivered without EPROM. If the old board has an up to date fully functioning EPROM it can be moved from the old to the new board. If any doubt replace to a new EPROM. The first digit of the EPROM version must match.
 - Version 4.XX = Model 88
 - Version 5.XX = Model 102 to Model 100
 - Version 6.XX = Model 102 to Model 310
3. Reset EEPROM according to PRG 9.1.
4. Program the paper sizes according to PRG 9.2.
5. Store into factory set memory according to PRG 9.3.

CAUTION: Handle the motor drive PCB according to Electrostatic Discharge (ESD) procedures. The driver board contains components that are susceptible to ESD damage.

REMOVAL

1. Switch off the main power switch and disconnect the power cord.
2. Remove rear cover according to REP 1.1.
3. Disconnect the plugs (1).
4. Remove the four screw (2) and carefully pull PCB down to disengage from logic board.

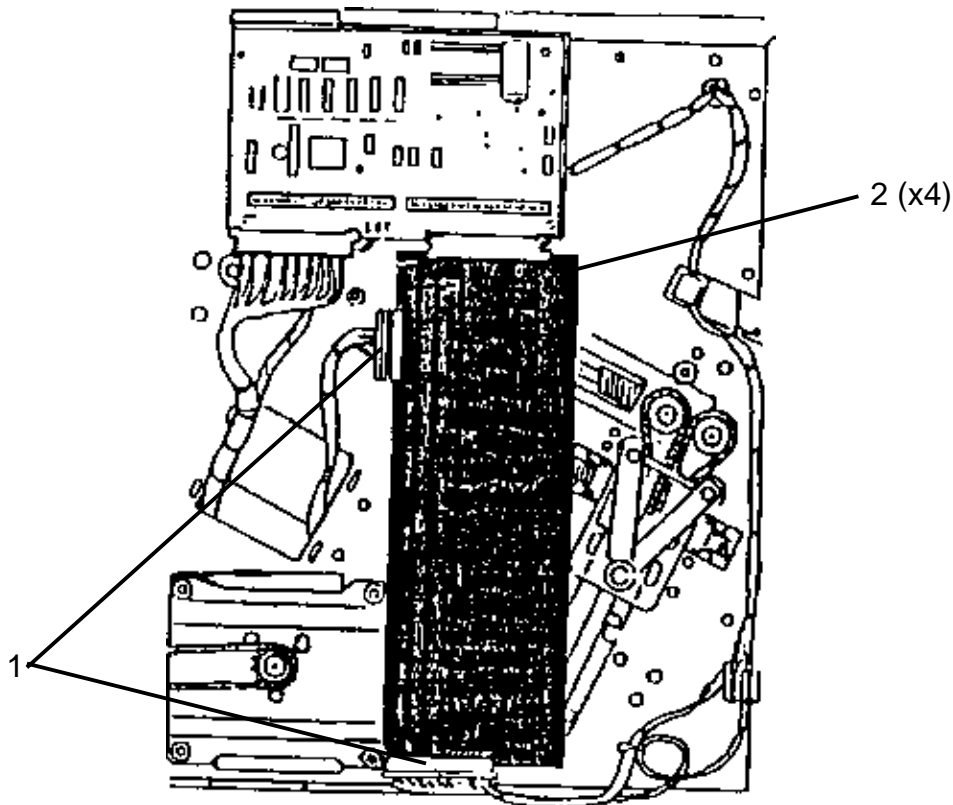

INSTALLATION

1. Installation is an exact reversed procedure as removal.

NOTE: Model 102 drive board is compatible with both Model 88 and Model 102. Model 88 drive board is not compatible with Model 102. If the drive board is fully compatible it is labeled: 880245C-UL or greater.

CAUTION: Handle the PCB according to Electrostatic Discharge (ESD) procedures. The PCB contains components that are susceptible to ESD damage.

REMOVAL

1. Switch off the main power switch and disconnect the power cord.
2. Remove rear cover according to REP 1.1.
3. Disconnect the plugs (1).
4. Remove the screws (2) holding the PCB, remove PCB.

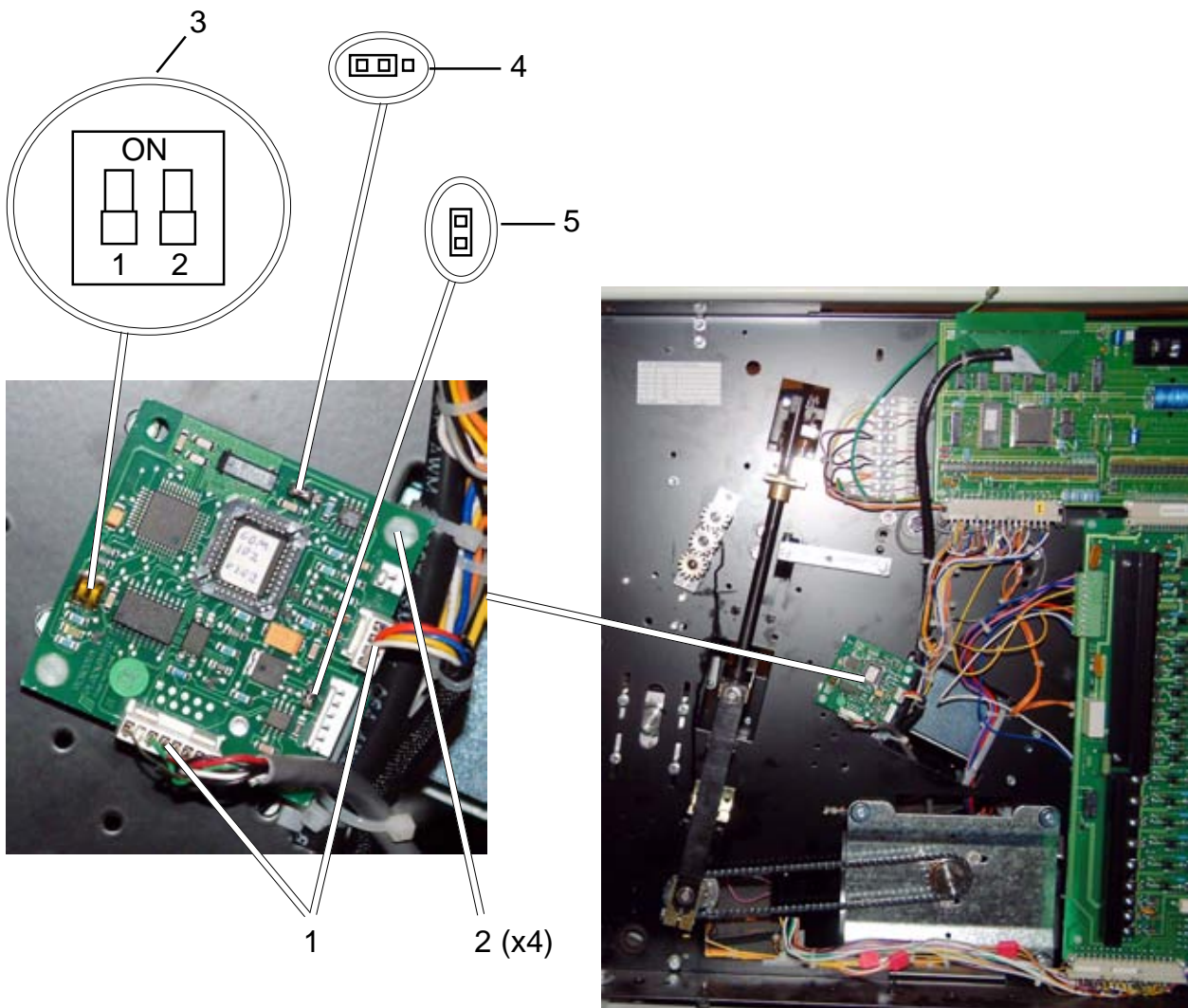

INSTALLATION

1. See figures above:
 Make sure both DIP switches are in off position (3).
 Make sure that on the upper three pins there is a jumper on the two leftmost pins (4).
 Make sure that on the right lower two pins there is a jumper (5).

CAUTION: Handle the front panel according to *Electrostatic Discharge (ESD)* procedures. The front panel components that are susceptible to ESD damage.

REMOVAL

1. Switch off the main power and disconnect the power cord.
2. Remove front cover according to REP 1.1.
3. Disconnect the panel from the ribbon cable plug.
4. Remove the old panel. (When tearing off the panel it will be damaged).

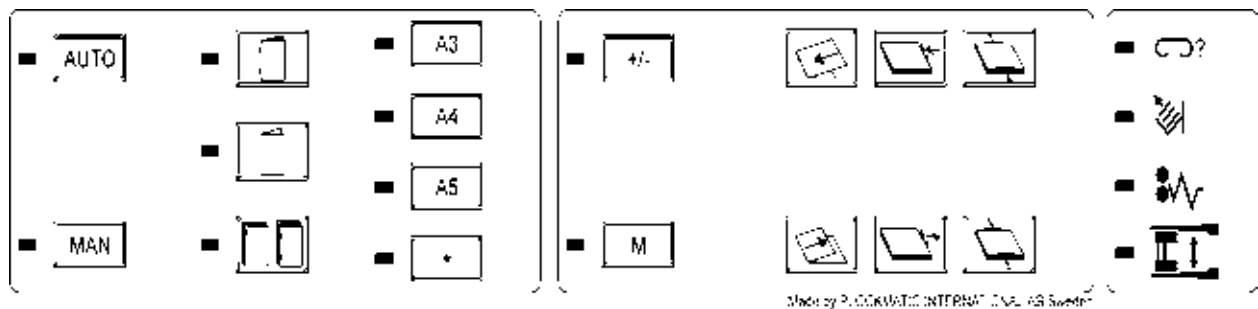

INSTALLATION

1. Clean the panel bracket with alcohol cleaner and remove the protective film on the back of new panel.
2. Place the panel centred on the panel bracket, and run the connector through opening in the panel bracket.
3. Connect the panel to the ribbon cable plug.

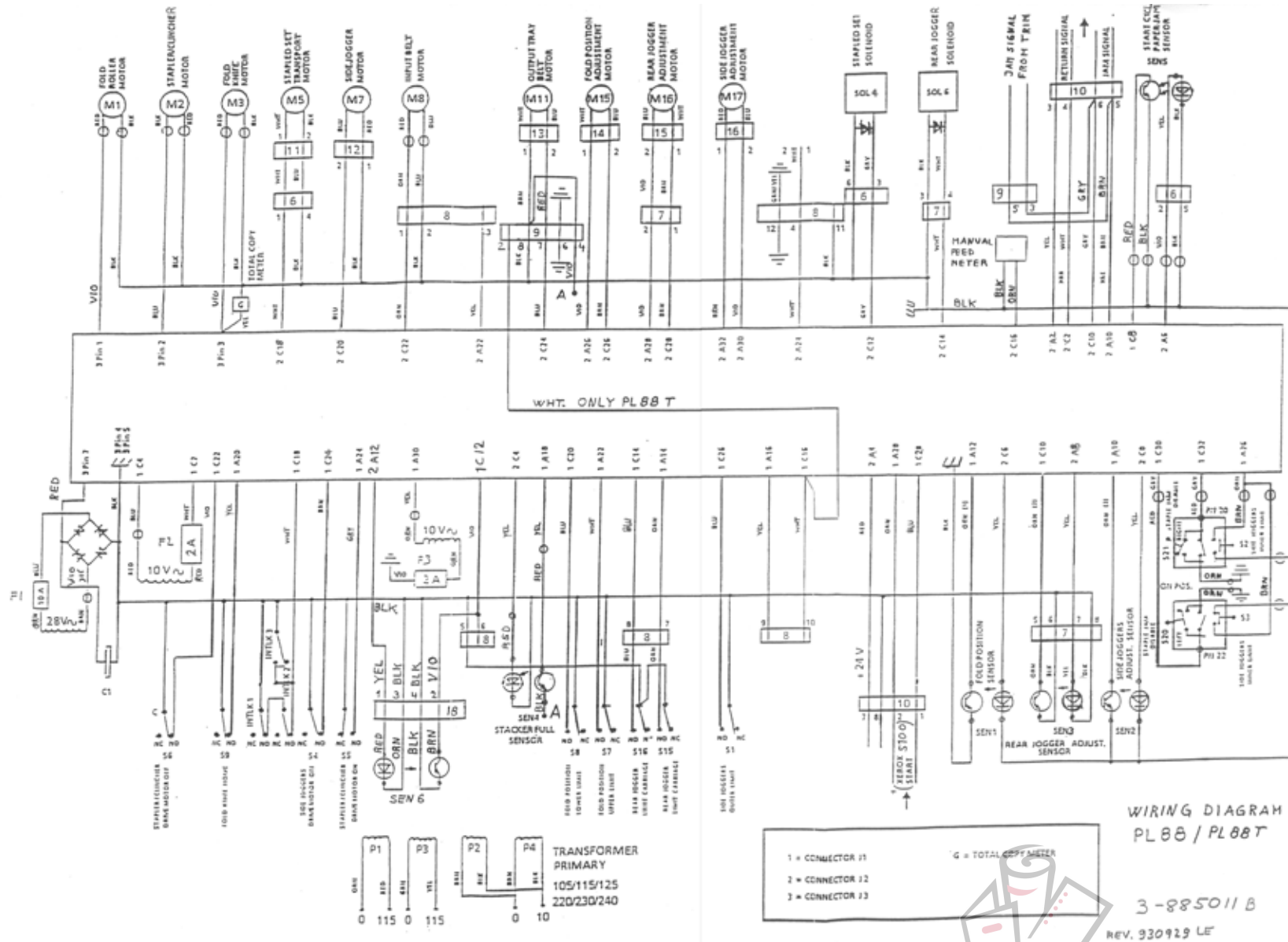

The copyright ownership of this document is and will remain ours. The document must not be used without our authorization or brought to the knowledge of a third party.
PLOCKMATIC International AB

PWB PL 88-2 A

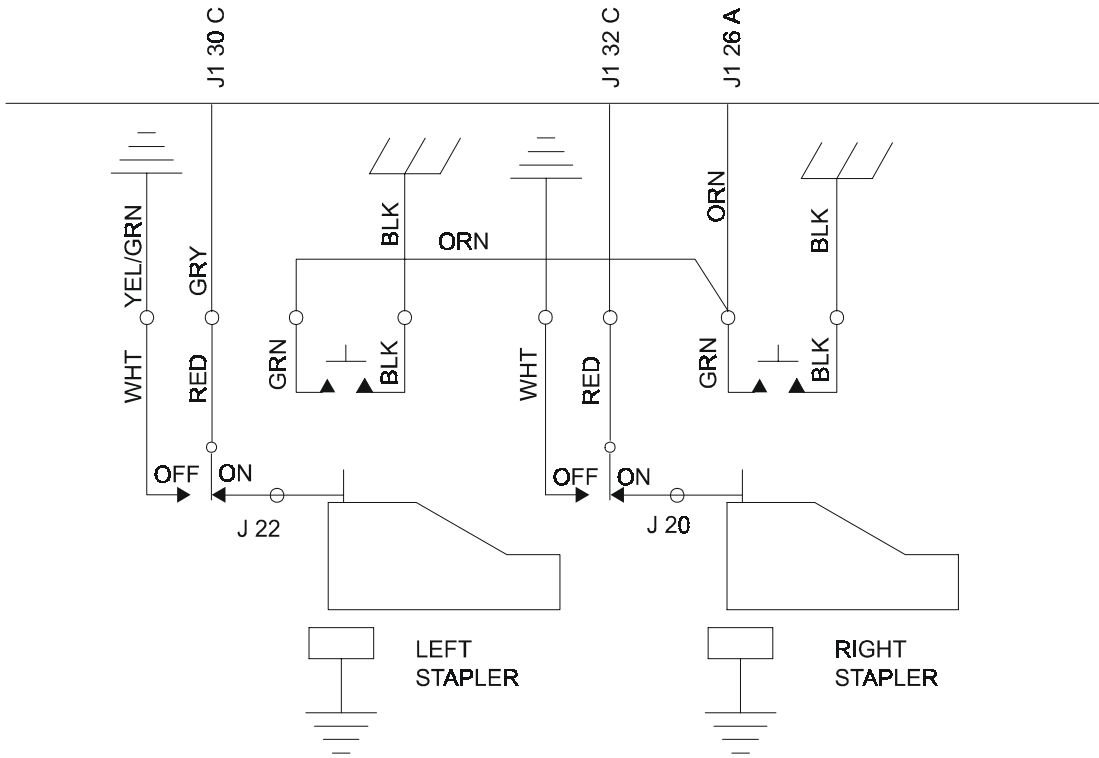



Det.nr (Ant.)		Benämning			Material		Mod.nr Ämne Dimension		Anm.	
Konstr.	Ritad LE	Kontr.	Godk.	Stand.	Skala	Format A4			Rev.dat.	
PLOCKMATIC International AB							Staple detection WIRING DIAGRAM		Art.nr.	Dat.
									4-885015	

The copyright ownership of this document is and will remain ours. The document must not be used without our authorization or brought to the knowledge of a third party. PLOCKMATIC International AB

Model 88/102
DIN CONNECTOR

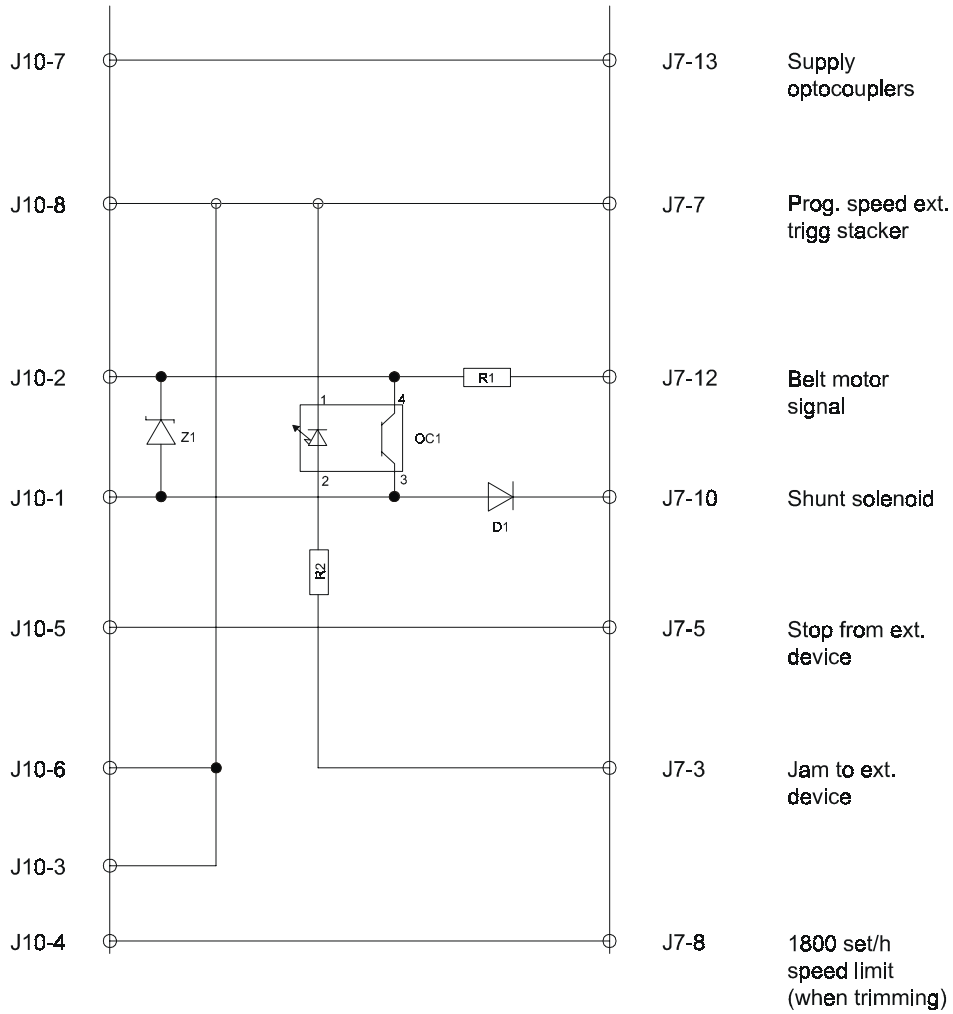
Model 300/400
AMP CONNECTOR



Det.nr (Ant.)		Benämning			Material		Mod.nr Ämne Dimension		Anm.	
Konstr.	Ritad	Kontr.	Godk.	Stand.	Skala	Format			Rev.dat.	
UT	BjH					A4			940829 UT	
 Connection cable Wiring Model 88/102 to Model 300/400							Art.nr.		Dat.	
							Ritn.nr.		4-905008 A	



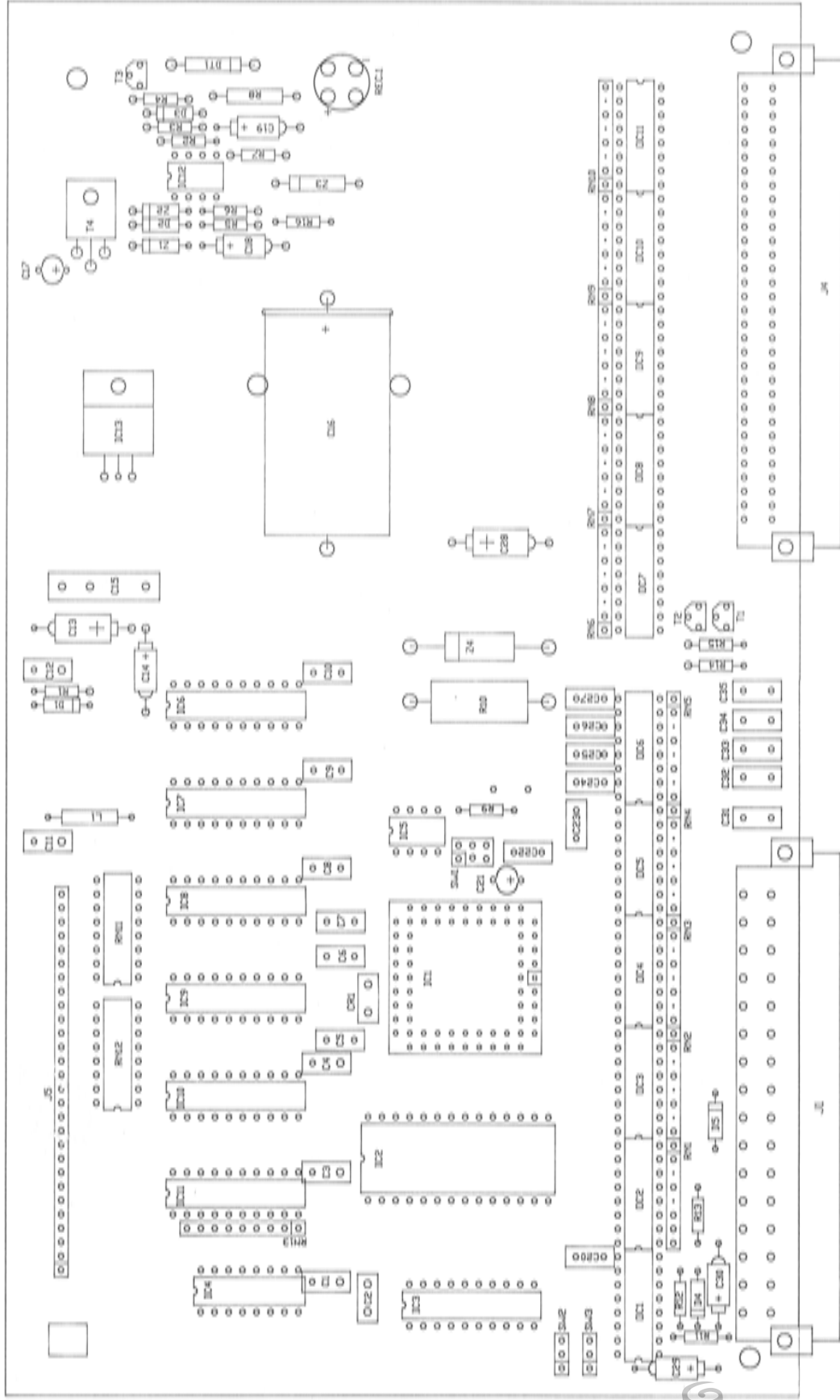

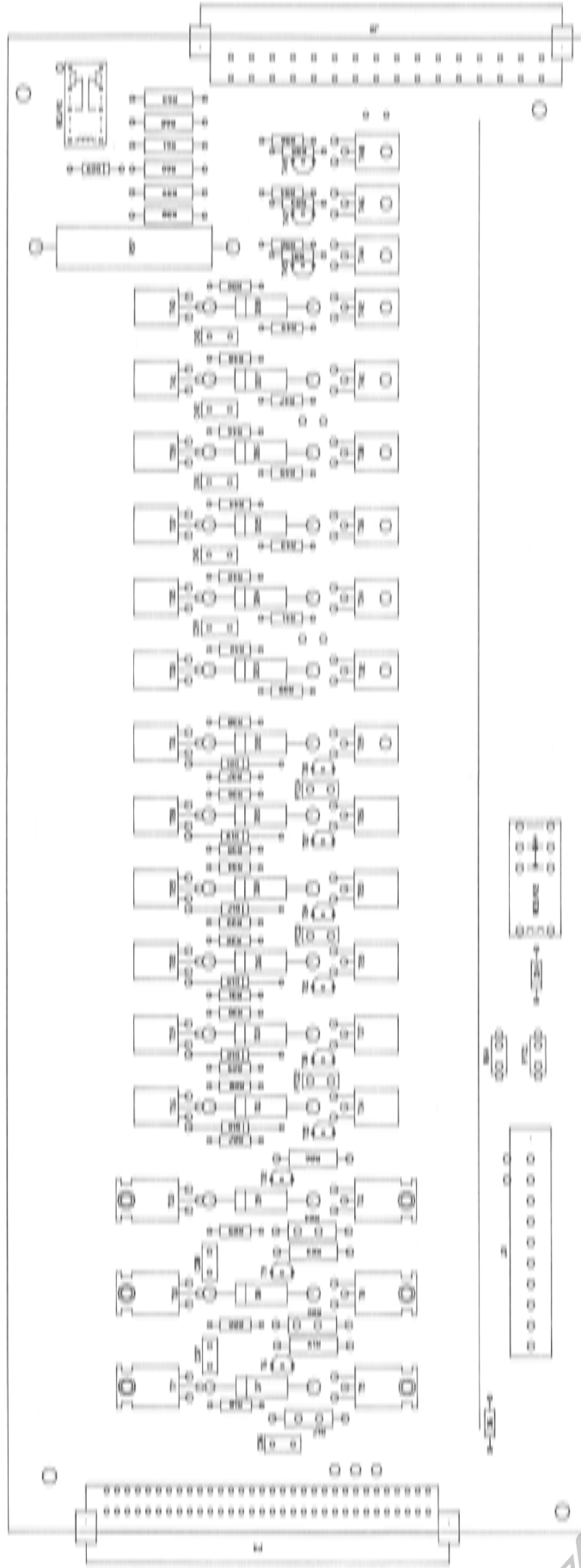

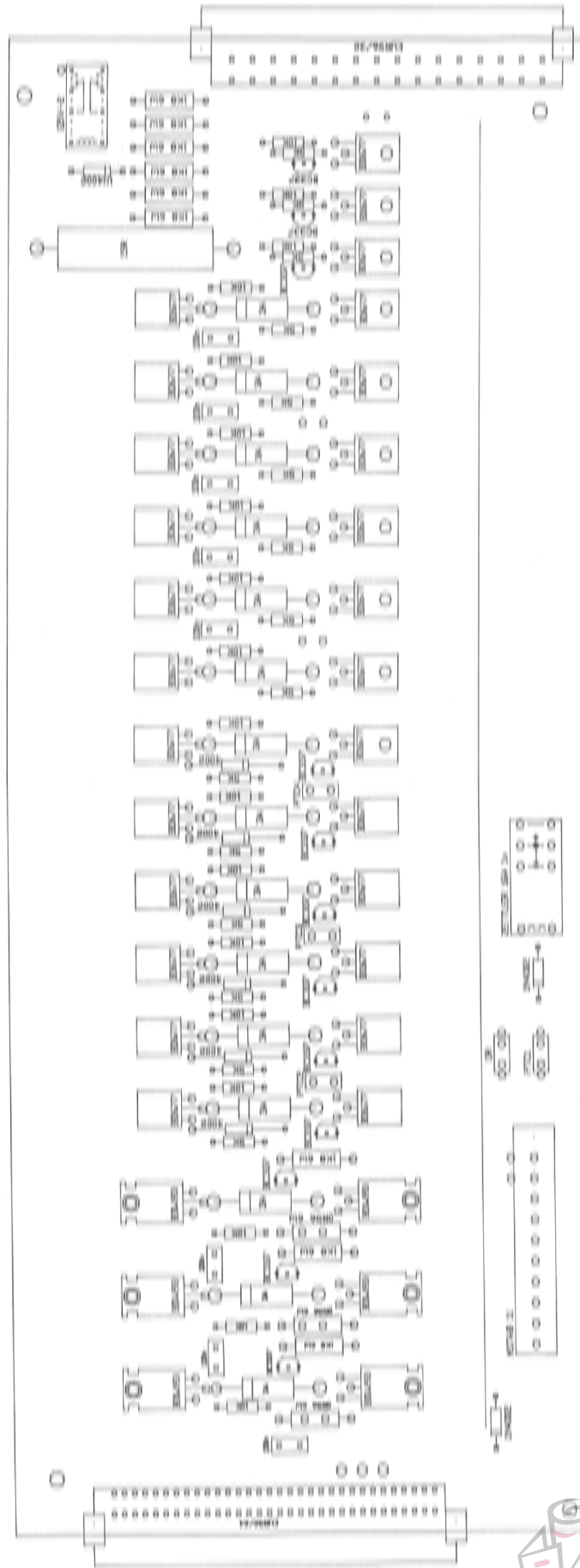

CAUTION: Handle the logic PCB according to Electrostatic Discharge (ESD) procedures. The logic board contains components that are susceptible to ESD damage.

PURPOSE

To initiate the EEPROM reset process in response to major logic problems. The procedure restores default machine cycle values.

CAUTION: If resetting the EEPROM all factory set paper sizes will be lost and must be reprogrammed.

Before initiating the procedure make sure you have the following paper sizes, preferably of 80 gsm or 20 pound bond.:

Model 102 (metric)	Model 102 (inch)	Model 88 (metric)	Model 88 (inch)
100 x A3	100 x 11x17"	100 x A3	100 x 11x17"
150 x A4	100 x 8.5x14"	100 x A4	100 x 8.5x14"
100 x A5	150 x 8.5x11"		100 x 8.5x11"
	100 x 5.5x8.5"		

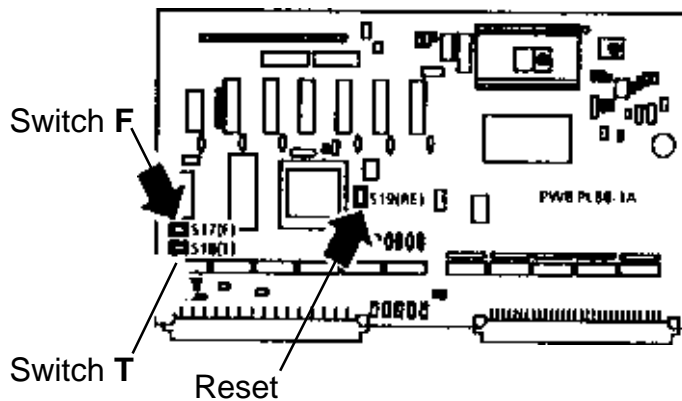

PROCEDURE

1. Switch on the power.
2. Remove cover according to REP 1.1.
2. Slide switch [F] and switch [T] to the far right position.
3. Press and release the [Reset] switch.

NOTE: All the control panel indicator LEDs will come on and go off.
4. Slide switch [F] and switch [T] back to the far left position.
5. Press and release the [Reset] switch.

NOTE: On the control panel only the [MAN] indicator LED will come on.
6. Set up and store a paper size into operator memory according to PRG 9.2. Store the paper size into the factory memory according to PRG 9.3. Repeat step 6 for each paper size to be programmed.

NOTE: Paper is used as reference in this procedure. Therefore it is important that the paper quality is good and that the paper size tolerances are kept at a minimum. Paper weight should preferably be 80 gsm or 20 pound bond.

Procedure

1. Press the Staple/fold button or Edge/Corner staple button, which ever to be set up.

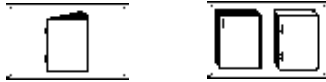

2. Press a paper size button, which ever to be set up.

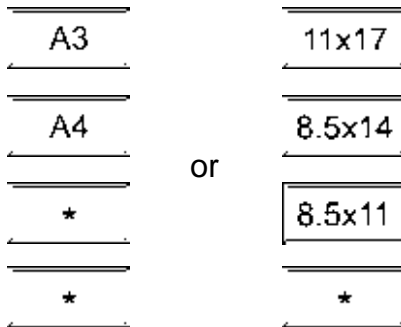

3. Press the [+/-] button.

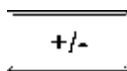

4. Open the top cover.
5. Adjust the side joggers to the scale mark for the paper size selected.
Press or pulse side jogger button to adjust.



6. Adjust the back jogger slightly larger than the scale mark for the paper size selected.
Press or pulse back jogger button to adjust.



7. Adjust the registration carriage to the far left position or large enough for the paper size selected.
Press or pulse registration carriage button to adjust.



8. Feed a 4-sheet set into the machine.

NOTE: When the set reaches the registration stop, the side joggers and back jogger will start cycling.

9. Adjust the registration position so top of the set is at the scale mark for the paper size selected.

Press or pulse registration carriage button to adjust.



10. Adjust the back jogger so there is 1mm clearance between trail edge of the set and back jogger.

Press or pulse back jogger button to adjust.



11. Adjust the side joggers so they touch the sides of the set without buckle the set.

Press or pulse side jogger button to adjust.



12. Press the memory button.

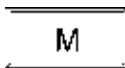

NOTE: The paper size selected is now stored into the operator memory. It can be verified by retrieving the paper size by pressing the paper size button (and booklet mode button) when top cover is closed.

13. Close the top cover.

NOTE: The set will be processed through the machine.

14. Hand feed five test sets of 4-sheets through machine.

15. Check the test sets by placing them on a flat surface and make sure:

- The fold is centered, edges aligned
- The sheets are jogged together length and side ways.
- There are no marks from the back jogger or side joggers.

16. Fine adjust if necessary according to following:

- a) Press the [+/-] button.
- b) Open the top cover:
- c) Feed a 4-sheet set into the machine.
- d) Perform necessary adjustments.
- e) Repeat step 12 through 16 until perfect result.

Note: If any of the limit or home position switches are actuated the paper size will not be stored into the memory.

Check/adjust limit or home position switches according to: REP 3.8 (side jogger home), REP 3.9 (side jogger limit), REP 3.13 (registration carriage) or REP 3.15 (back jogger) if necessary.

The following paper sizes should be stored into the factory memory.

Model 102 (metric)	Model 102 (inch)	Model 88 (metric)	Model 88 (inch)
A3 Staple/Fold	11x17" Staple/Fold	A3 Staple/Fold	11x17" Staple/Fold
A4 Staple/Fold	8.5x14" Staple/Fold	A4 Staple/Fold	8.5x14" Staple/Fold
A5 Staple/Fold	8.5x11" Staple/Fold		8.5x11" Staple/Fold
A4 Edge staple	5.5x8.5" Staple/Fold 8.5x11" Edge staple		

PROCEDURE

1. Make sure paper size to be stored is selected on the control panel.
2. Press the [+/-] button on the control panel.

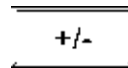

3. Slide switch [F] to the far right position.

NOTE: The red control panel indicator LEDs will come on and go off.

4. Slide switch [F] back to the far left position.

5. Press and release the [Reset] switch.

NOTE: The paper size selected is now stored into the factory memory. It can be verified by retrieving the paper size according to PRG 9.4.

6. Repeat this procedure for each paper size to be stored into the factory memory.

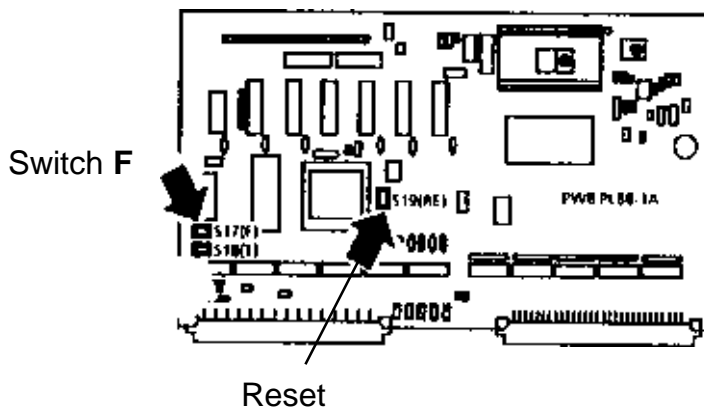

PROCEDURE

1. Switch on the power.
2. Press and hold the paper size button for the paper size to be retrieved from the factory memory.

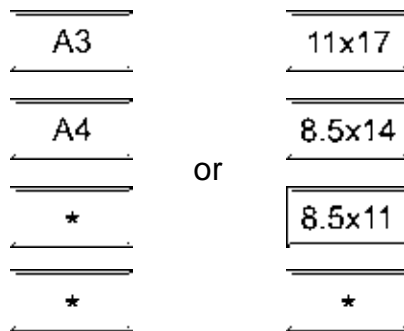

3. Hold the button until the corresponding indicator LED goes out and comes on again.
4. Release the paper size button.
5. Select booklet making mode.

NOTE: *The paper size programmed in the factory memory will be retrieved for the selected paper size.*



PURPOSE

To allow adjustment of the machine cycle time delays, within the stapler/folder software, in order to compensate for variable times of the mechanical sub assemblies to the logic program. This can be used to increase the reliability when nonstandard configurations are used.

PROCEDURE

1. Remove the rear cover according to REP 1.1.
2. Switch on the power
3. Pull out the Interlock bypass switch
4. Slide switch [T] to the far right position.

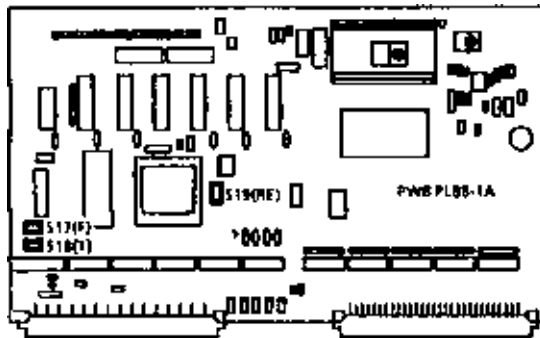

5. See table 1 below. Locate the description of the Delay function to be adjusted and note associated function number.

NOTE: Remove the rear cover and locate lable attached on the side frame explaining delays for installed program version. The "original time" shown in the table below might vary between different program versions.

Delay Function	Function Number	Original * Time
The delay between the energizing of the Start cycle sensor, SEN 5, and the start of the Side jogger drive motor, MOT 7.	1	0,0 sec
The delay between the start of the Stapler/Clincher drive motor, MOT 2, and the the energizing of the Registration Stop solenoid, SOL 4	2	0,2 sec
The delay between the energizing of the Registration Stop solenoid, SOL 4, and the start of the Eject motor, MOT 5.	3	0,27 sec
The delay between the Outfeed full sensor, SEN 4, is cleared and the start of the Stacker motor, MOT 11.	4	0,4 sec
The delay between the Outfeed full sensor, SEN 4, is cleared and stop of the Stacker motor, MOT 11.	5	0,45 sec
The delay between the start of the Eject motor, MOT 5, and the start of the Fold knife motor, MOT 3.	6	0,85 sec

* For Model 88 version 4.43

6. Locate the Control button with the function number. Press the button in order to enter the programmable memory of the time delay.

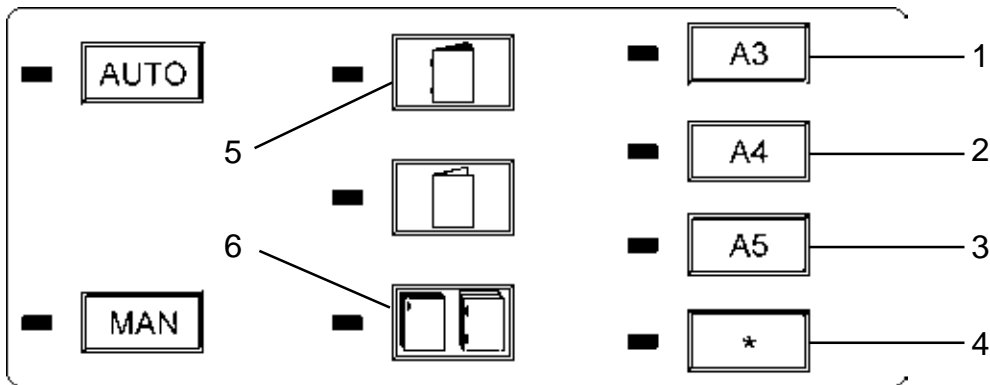

7. See table below. Locate the time change function which is required. Note associated function number.

Time change function	Function Number
Increase the delay time	1
Decrease the delay time	2
Return to original time	3

8. Find the control panel button with the function number. Press the button in order to change time delay. Each time one of the buttons are pressed, the delay time is changed with 0.01 sec.

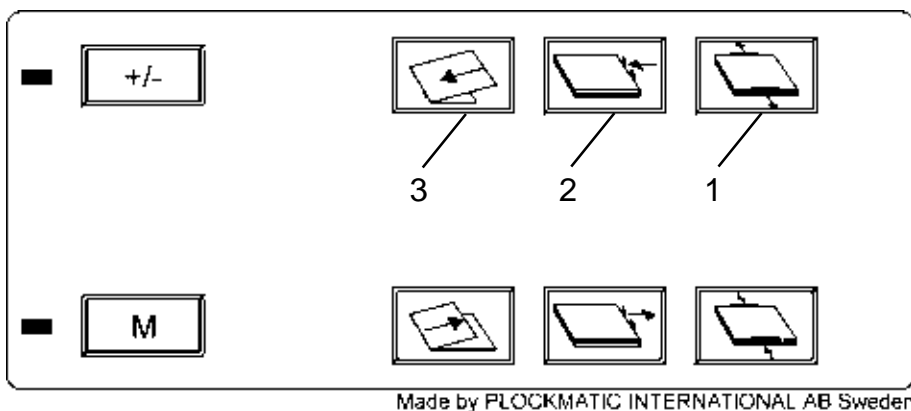

NOTE: If the return to original value button is pressed, the manual and auto indicator LED's will come on. If the time delay period is increased or decreased, the total time delay increase or decrease can be calculated.

The control panel LED's will come on in a sequence which indicates the total selected delay in a binary code. Add the illuminated LEDs for the total time delay.

After the binary count reaches 32 x 0,01 second, the LED display sequence will repeat and the 1 x 0,01 second LED will remain on as a reminder that the count has cycled once. During the second cycle, the displayed binary value must be added to the original maximum count of 32 x 0.01 second. The location and value assigned to each LED is shown below.

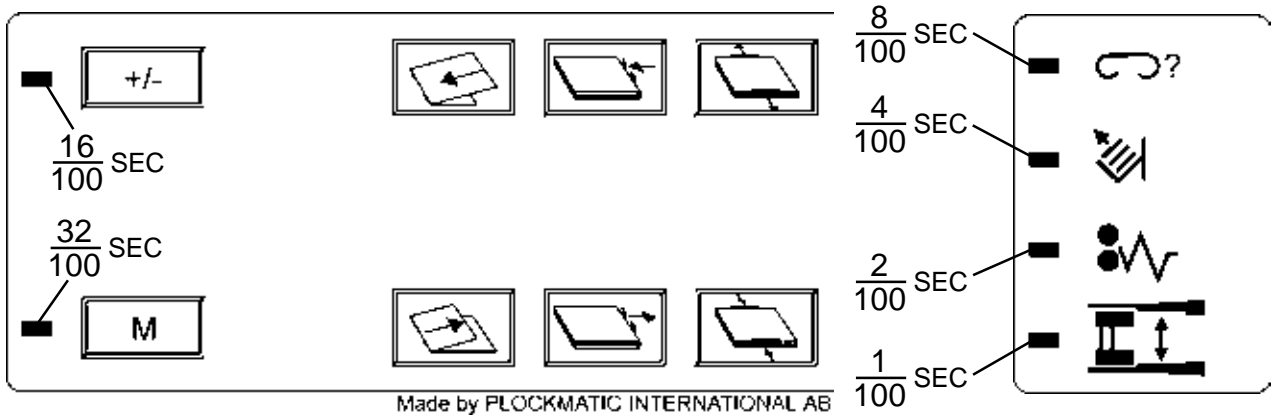

9. After appropriate time delay period is entered; slide switch [T] to the far left position.
10. Press the [Reset] switch. The new time delay period is entered into the memory. The machine will initialize and go back to the normal operating mode.

PURPOSE

This feature allows the energizing of each motor and solenoid for diagnostical purpose. The feature can be used when trouble shooting supposedly faulty motors and solenoids with associated assemblies and subsystem. The feature can also be used to move assemblies and simulate functions. When performing the diagnostic component control the logic PCB is overridden but the motor drive PCB is in use.

WARNING: When doing the diagnostic component control procedure, be sure to stay clear of all mechanical assemblies in order to avoid personal injury. Sudden mechanical movements may occur when electromechanical components are energized.

CAUTION: When energizing a component with a jumper wire, home- and limit position switches are overridden. Do not run motors to their mechanical stops as it may cause damage to the machine.

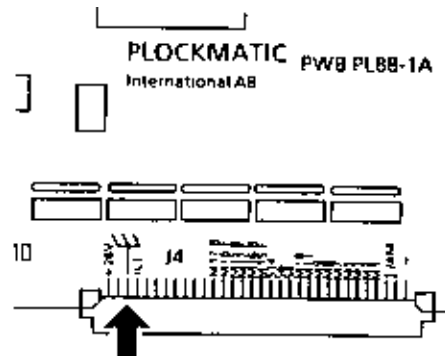

PROCEDURE

1. Switch on the power.
2. Pull out the interlock bypass switch, INTLK 3.
3. Locate the connector J4 on PCB PL88-1.
4. Connect a jumper to the pin marked with an inverted common ground symbol.
CAUTION: Do not allow free end of wire to contact any machine surface or pins other than intended, to prevent damage to the Machine components.
5. See table below. Locate the code for the component to be checked.
6. On connector J4, locate the pin labeled with that code.
7. Make a brief contact on that pin with the other end of the jumper wire.
NOTE: The component will energize immediately upon contact and stay energized until jumper is removed from the pin.

Component name	Code
Side jogger Adjustment motor, MOT 17(B rotation)	M 17 B
Back jogger Adjustment motor, MOT 16 (F rotation)	M 16 F
Fold position motor, MOT 15 (B rotation)	M 15 B
Side jogger adjustment motor, MOT 17 (F rotation)	M 17 F
Back jogger Adjustment motor, MOT 16 (B rotation)	M 16 B
Fold position motor, MOT 15 (F rotation)	M 15 F
Stacker motor, MOT 11	M 11
Infeed belt motor, MOT 8	M8
Side jogger drive motor, MOT 7	M7
Eject motor, MOT 5	M5
Fold knife motor, MOT 3	M 3
Stapler/Clincher drive motor, MOT 2	M2
Fold roller drive motor, MOT 1	M 1

Component name	Code
Manual copy count meter; (H)	S 14
Back jogger solenoid, SOL 6	S 6
Registration stop solenoid, SOL 4	S 4

NOTE: Reversing motors are listed twice, once per direction: B=Backward, F=Forward.

FIP 10.2 Fault Isolating Procedure cont.

NOTE: During the time that the machine is setting the Paper size (indicated by flashing paper size LED's) the Stapler/folder will ignore any attempt to clear a jam before the size setting is complete.

If Top cover is open during the size setting, the Paper size setting will stop and the Stapler/folder has to be switched off and then back on again and papersize has to be reselected. This is to prevent any missettings of the paper sizes.

After approximately 25 seconds the setting is completed and the LED's on the Front panel will have a solid light.

SEQUENCE OF OPERATION	OBSERVED FAULT	POSSIBLE CAUSE	FAULT ISOLATING/ REPAIR
The Stapler/folder is switched on.	Front panel does not come on.	Fuse F2 blown.	If LEDs inside machine is illuminated.
		Front panel connector lose.	Connect Front panel to Connector J5 on Logic PCB.
		Front panel defective.	Replace Front panel acc. to REP 7.4
		Logic PCB defective.	Replace Logic PCB acc. to REP 7.1.
		AC power supply defective	Check main fuse. Reset the Ground Fault Interrupter (GFI). Check for appropriate voltage at GFI, Main power switch and Transformer. Replace as needed.
Paper size and stapling mode is chosen.	The paper size indicator keeps flashing and the joggers and registration never reached their correct position.	One of the adjustment motors is broken or disconnected.	Open the top cover and see which one of motor MOT 15, 16 or 17 that has not reached the home (outer) position. Check motor according to FIP 10.1 Check connectors and transmission. Adjust or replace the motor acc. to REP 5.15-5.17 if broken.
		One of the adjustment motor position sensor is malfunctioning.	Open the top cover and see which one of the motor MOT 15, 16 or 17 that has passed the correct size position and proceeded all the way in. Check position sensor for that motor; connector, function and position.

FIP 10.2 Fault Isolating Procedure cont.

SEQUENCE OF OPERATION	OBSERVED FAULT	POSSIBLE CAUSE	FAULT ISOLATING/ REPAIR
Paper size and stapling mode is chosen.	The paper size indicator keeps flashing and joggers and registration never reached their home position and stays in or passed the home (outer) position.	One of the Jogger/Registration carriage home position switch is faulty.	Open the top cover and see which motor has passed the home position switch and reached mechanical stop. Check that home position switch SW 1, 8 or 15/16; connector, function and position. As the motor assembly has reached mechanical stop there is a risk that parts associated with that assembly has been damaged.
	The paper size indicator keeps flashing and the joggers and registration never reached their correct position.	Top cover open.	Close the Top cover.
		Top cover interlock failure.	Check switch for 0 VDC when activated and approximately 28 VDC when not. Adjust/Replace switch acc. to REP 3.17
		Fuse (F1), rectifier, capacitor or transformer defective. (Driver PCB supply).	Check for 24 VDC between J3-7 and common ground. See wiring diagram.
		Fuse(F2) or transformer defective. (Logic PCB supply).	Check for 8 VAC between pin J1-4Cand J1-2C. See wiring diagram.
Paper size setting is in progress. Indicators on Front panel comes on. Size setting is interrupted.	Stapler/Side jogger incorrectly positioned indicator lights up.	Stapler heads moved out so the actuator on side guide has actuated SW2 or SW3.	Move stapler heads toward each other to the correct position for the paper size to be run.
Trimmer is installed. Machines are running. Indicator on Front panel comes on.	Stacker full indicator comes on in stapler/folder and jam indicator on trimmer by the time of stapling action.	Outfeed sensor SEN4 is not correctly positioned or dirty. The power dip when stapling makes the sensor go blocked.	Clean sensor and LED. Measure voltage between TP2 and common ground on trimmer according to REP 3.4.
Machines are running. Indicator on Front panel comes on.	Stapler detection indicator is on.	Stapler indication lead disconnected.	Connect lead acc. to Operator manual.

FIP 10.2 Fault Isolating Procedure cont.

SEQUENCE OF OPERATION	OBSERVED FAULT	POSSIBLE CAUSE	FAULT ISOLATING/ REPAIR
Machines are running. Indicator on Front panel comes on. (Cont.)	Stapler detection indicator is on.	Fuse (F3) defective. (Stapler detection supply).	Check for approximatly 8 VAC between pin J1-30A and machine frame. See wiring diagram
		Stapler head worn out so contact between metal parts in stapler head bad.	Replace stapler head every 250 000 cycles.
Paper size setting is complete. The Stapler/folder is ready to receive sets.	Infeed belt does not energise.Infeed motor is running.	Drive O-ring/Drive belt broken.	Replace acc. to REP 6.1 - 6.2
		Pulley lose on shaft.	Adjust/Replace acc. to REP 5.6 or 11.1
		Drive belt slips on pulley.	Adjust motor position acc. to REP 5.6
		Motor wires not properly connected.	Check and connect motor to terminal block.
		Motor defective.	Check motor acc. to FIP 10.1. Replace acc. to REP 5.13 if defective.
A set has been fed into the Stapler/folder.	The set is fed into the Stapler/folder but stops at the Registration gate. No jogging is done.	Set is stuck on Side joggers and do not reach the Set registration sensor.	Side joggers position too narrow. Adjust to wider position acc to PRG 9.2.
		Rear end of set has not cleared the infeed sensor SEN6.	Clear the Side joggers from any obstaclesand/or adjust Side joggers as above.
		Infeed sensor SEN6 is defective or misadjusted.	Check that sensor acc. to REP 3.6
		Start cycle LED failed.	Check if LED is emitting red light. Check voltage from J2-6A to common ground. App. 2 VDC means LED is OK. App. 28 VDC means LED defective. See wiring diagram.
		Start cycle sensor SEN5 failed.	Check sensor acc. to REP 3.5.

FIP 10.2 Fault Isolating Procedure cont.

SEQUENCE OF OPERATION	OBSERVED FAULT	POSSIBLE CAUSE	FAULT ISOLATING/ REPAIR
Set is jogged.	Side joggers and Stapler heads run continuously.	Side jogger off switch (SW 4) defective.	Replace switch acc. to REP 3.10.
	Set is jogged but not Stapled. (Stapling is chosen).	Stapler motor on switch (SW 5) defective.	Replace switch acc. to REP 3.11.
Set is Stapled.	Staple heads run continuously.	Stapler motor home switch (SW 6) defective.	Replace switch acc to REP 3.12.
	Set does not leave the Set registration position.	Registration stop solenoid/Solenoid linkage failed.	Replace/Adjust solenoid acc. to REP 4.1.
		Eject motor drive O-ring broken or worn out.	Replace O-ring acc. to REP 5.9.
		Eject motor defective.	Replace/Adjust motor acc. to REP 5.9.
		Deformed Stapler jammed in Stapler head or clincher possibly caused by Stapler head not in correct position.	Lift out Stapler head from Holder acc. to Operator manual, remove jammed Staple, check Stapler head function and reinstall Stapler head. Check that the Stapler head is correctly positioned to the clinchers and that the thumb screws are tightened.
	Stapler heads stopps in lower position. Possibly the stapler chain jumps the sprocket as well.	Clinchers dry or have burrs.	The clinchers should be lubricated with thin oil at least every 20 000 cycles. Check clinchers acc. to REP 5.5.
	Set leaves the Stapler area but does not reach Fold position correctly. Paper transport motor is running.	Prefold transport belts broken or worn.	Replace belts acc. to REP 6.3.
		Sprocket on Paper transport motor lose/defective.	Replace Sprocket/Tighten screws in Sprocket.
		Prefold transport belt pulleys lose on shaft.	Tighten screws/Replace pulleys.

FIP 10.2 Fault Isolating Procedure cont.

SEQUENCE OF OPERATION	OBSERVED FAULT	POSSIBLE CAUSE	FAULT ISOLATING/ REPAIR
Set reaches Fold position.	Fuse (F1) fails when Fold motor starts.	Incorrect type of Fuse.	Replace Fuse with 16A Slow blow Fuse.
Set is Folded.	A Fold roller does not rotate.	Sprocket lose on roller.	Tighten screws in sprocket/Replace sprocket.
Set is fed out to the Belt stacker.	Belt stacker does not energise.	DIN plug not connected to main unit or broken wire.	Connect/repair DIN plug/wire.
FAULTS NOT RELATED TO OPERATING SEQUENCE.	Stapler indicator does not come on when staples are missing.	Staple missing detection switch in disabled position.	Slide switch to enabled position acc. to Operator manual.
		Stapler jammed in stapler head and makes contact with Clincher assemblies through each set.	Remove jammed stapler head from Stapler bracket. Check Stapler head function and Stapler head bracket position acc. to Operator manual and/or REP 5.5
		Stapler detection switch defective.	Check switch by connecting the Staple detection lead to machine frame during stapling. Replace Stapler detection switches acc. to REP 3.16.
	Plastic post on stapler heads breaks frequently.	Stapler lift bracket deformed due to stapler heads installed incorrectly.	Replace stapler lift bracket. Check stapler compression acc. to REP. 5.7. Replace stapler head.

Service interval: 250 000

NOTE: All instructions are referring to the stapler/folder model 88-102 Service Manual.

The reference column is referring to the Spare Parts Manual.

CAUTION: If any of the checkpoints or other parts show indication of wear at any point, replace the part. When lubricating, clean the surface if necessary before applying new lubricant.

CHECK POINT	INSTRUCTION	REFERENCE	250000	500000
All Machine, Paper paths etc.	Use a vacuum cleaner, towels and brushes to clean the machine from paper dust. Use an alcohol to clean from ink.		Clean	Clean
Interlock switches	Check function of the switches. Adjust according to REP 3.17.		Check/Adj	Check/Adj
Stapler drive chain	Apply chain oil. Check for wear, if worn/stretched replace. Always replace at 1000 000.	Page 1.49 Item 12	Oil	Oil
Stapler head assembly	Remove the stapler head. Apply grease on stapler drive guide pin and the Stapler lift bracket assy.	Page 1.25 Item 1	Replace	Replace
Stapler push rod	Apply grease on Stapler push rod.	Page 1.27 Item 1	Grease	Grease
Clincher push rod	Apply grease on Clincher push rod.	Page 1.27 Item 9	Grease	Grease
Clincher assembly	Apply a drop of oil in each Clincher assembly. Remove the clincher assembly and dismantle the clincher for cleaning every 500 000. Check that the clincher are mounted according to REP 5.5.	Page 1.29 Item 4 & 7 & 9	Oil/Check	Oil/Check
Stapler/Clincher home switch (SW 6)	Check function of the switch. Adjust according to REP 3.12.	Page 1.25 Item 14	Check/Adj	Check/Adj
Start cycle sensor (SEN 5)	Use compressed air. Adjust according to REP 3.5	Page 1.31 Item 4	Clean/Adj	Clean/Adj
Fold position adjustment sensor (SEN 1)	Use compressed air. Adjust according to REP 3.1.	Page 1.31 Item 7	Clean/Adj	Clean/Adj
Fold position adjustment motor (MOT 15)	Apply grease on gear and gear rack. Check adjustment according to REP 5.15.	Page 1.31 Item 2		Grease
Pre-fold transport belt	Clean with a rubber reactivator alcohol fluid. If the transport belt is stiff and rotates poorly, replace the Pre-fold transport belt according to REP 6.3.	Page 1.37 Item 6	Clean	Replace
Pre-fold belt Sprocket	Apply chain oil on sprocket. Replace the sprocket when the Pre-fold transport belt is replaced.	Page 1.47 Item 2	Oil	Replace
Fold Roller upper	Use a rubber reactivator alcohol fluid to clean the fold rollers from ink.	Page 1.45 Item 8	Clean	Clean
Fold roller tensioner (lower)	Apply grease between Frame and Slide housing. (4X).	Page 1.43 Item 1 & 2 & 3 & 4		Grease
Fold drive Chain	Apply chain oil. Check for wear, if worn replace. Always replace at 1000 000.	Page 1.47 Item 5	Oil	Oil

CHECK POINT	INSTRUCTION	REFERENCE	250000	500000
Fold roller drive chain tensioner(Front side)	Apply grease between idler wheel and shaft. Check for wear, if worn replace. Replace the three (3) idler wheels every 1000 000.	Page 47 Item 1	Grease	Grease
Fold roller idler chain tensioner (Rear side)	Apply grease between idler wheel and shaft. Check for wear, if worn replace. Replace the two (2) idler wheels every 1000 000.	Page 1.49 Item 4	Grease	Grease
Fold knife home position switch (SW 9)	Check function of switch. Adjust according to REP 3.14.		Check/Adj	Check/Adj
Outfeed sensor	Use compressed air to clean the sensor and LED. Use an alcohol to clean the outfeed bracket from ink. Adjust the sensor according to REP 3.4.		Clean/Adj	Clean/Adj
Output transport belt	Clean with a rubber reactivator alcohol fluid.	Page 1.53 Item 12	Clean	Clean
Side jogger motor off switch (SW 4)	Check function of the switch. Adjust according to REP 3.10.	Page 1.15 Item 10	Check/Adj	Check/Adj
Stapler/Clincher motor on switch (SW 5)	Check function of the switch. Adjust according to REP 3.11.	Page 1.15 Item 10	Check/Adj	Check/Adj

Infeed module removed

Side jogger format mechanism	Apply grease on the threaded part of the shaft. Use oil on the flanged bushing.	Page 1.19 Item 3	Grease/Oil	Grease/Oil
Side jogger chain assembly	Apply chain oil. Check for wear, if worn replace.	Page 1.19 Item 8	Grease	Grease
Side jogger channel centering	Apply grease on the 3 gears and check adjustment according to REP 5.11.	Page 1.19 Item 15	Grease	Grease
Side jogger push rod centering	Apply grease between Side jogger push rod and flanged bushing, check adjustment according to REP 5.12	Page 1.17 Item 3	Grease	Grease
Side guide parallelism	Check that the side guides are parallel. Adjust if necessary.		Check	Check
Side jogger adjustment sensor (SEN 2)	Use compressed air. Adjust according to REP 3.2.	Page 1.19 Item 10	Clean/Adj	Clean/Adj
Infeed transport belt	Clean with a rubber reactivator alcohol fluid. Check for wear. If worn, replace, according to REP 6.2.	Page 1.7 Item 17	Clean/Oil	Clean/Oil
Infeed motor O-ring	Clean with a rubber reactivator alcohol fluid. Replace every 500 000 set, according to REP 6.1.	Page 1.9 Item 5	Clean	Replace
Infeed sensor (SEN 6)	Use compressed air to clean the sensor.	Page 1.13 Item 16	Clean/Adj	Clean/Adj
Back jogger sensor (SEN 3)	Use compressed air to clean the sensor. Adjust according to REP 3.3.	Page 1.13 Item 11	Clean/Adj	Clean/Adj
Back jogger solenoid (SOL 6)	Check for wear, if worn replace. Replace every 1000 000, acc to REP 4.2.	Page 1.13 Item 14		Check/Replace
Eject drive traction o-ring	Use a rubber reactivator alcohol fluid. Replace the motor o-ring every 500 000 set, according to REP 5.9.	Page 1.35 Item 15	Clean	Replace

FINAL CHECK POINTS

Booklet quality	Check the booklet quality. The booklet should be evenly folded and both staples should be placed in the centre of the spine.		Check	Check
-----------------	--	--	-------	-------

Service interval: 250 000

NOTE: All instructions are referring to the stapler/folder model 88-102 Service Manual.

The reference column is referring to the Spare Parts Manual.

CAUTION: If any of the checkpoints or other parts show indication of wear at any point, replace the part. When lubricating, clean the surface if necessary before applying new lubricant.

CHECK POINT	INSTRUCTION	REFERENCE	250000	500000
All Machine, Paper paths etc.	Use a vacuum cleaner, towels and brushes to clean the machine from paper dust. Use an alcohol to clean from ink.		Clean	Clean
Interlock switches	Check function of the switches. Adjust according to REP 3.17.		Check/Adj	Check/Adj
Stapler drive chain	Apply chain oil. Check for wear, if worn/stretched replace. Always replace at 1000 000.	Page 1.49 Item 12	Oil	Oil
Stapler head assembly	Remove the stapler head. Apply grease on stapler drive guide pin and the Stapler lift bracket assy.	Page 1.25 Item 1	Replace	Replace
Stapler push rod	Apply grease on Stapler push rod.	Page 1.27 Item 1	Grease	Grease
Clincher push rod	Apply grease on Clincher push rod.	Page 1.27 Item 9	Grease	Grease
Clincher assembly	Apply a drop of oil in each Clincher assembly. Remove the clincher assembly and dismantle the clincher for cleaning every 500 000. Check that the clinchers are mounted according to REP 5.5.	Page 1.29 Item 4 & 7 & 9	Oil/Check	Oil/Check
Side staple stop gate (In clincher housing)	Apply thin oil in each Stop assy. Check adjustment acc to REP 4.3.		Oil	Oil
Stapler/Clincher home switch(SW 6)	Check function of the switch. Adjust according to REP 3.7.5.	Page 1.25 Item 14	Check/Adj	Check/Adj
Start cycle sensor (SEN 5)	Use compressed air. Adjust according to REP 3.9.5.	Page 1.31 Item 4	Clean/Adj	Clean/Adj
Fold position adjustment sensor (SEN 1)	Use compressed air. Adjust according to REP 3.9.1.	Page 1.31 Item 7	Clean/Adj	Clean/Adj
Fold position adjustment motor (MOT 15)	Apply grease on gear and gear rack. Check adjustment according to REP 3.6.1.	Page 1.31 Item 2		Grease
Pre-fold transport belt	Clean with a rubber reactivator alcohol fluid. If the transport belt is stiff and rotates poorly, replace the Pre-fold transport belt according to REP 3.14.1.	Page 1.37 Item 6	Clean	Replace
Pre-fold belt Sprocket	Apply chain oil on sprocket. Replace the sprocket when the Pre-fold transport belt is replaced.	Page 1.47 Item 2	Oil	Replace
Fold Roller upper	Use a rubber reactivator alcohol fluid to clean the fold rollers from ink.	Page 1.45 Item 8	Clean	Clean
Fold roller tensioner (lower)	Apply grease between Frame and Slide housing. (4X).	Page 1.43 Item 1 & 2 & 3 & 4		Grease
Fold drive Chain	Apply chain oil. Check for wear, if worn replace. Always replace at 1000 000.	Page 1.47 Item 5	Oil	Oil
Fold roller drive chain tensioner(Front side)	Apply grease between idler wheel and shaft. Check for wear, if worn replace. Replace the three (3) idler wheels every 1000 000.	Page 1.47 Item 1	Grease	Grease

CHECK POINT	INSTRUCTION	REFERENCE	250000	500000
Fold roller idler chain tensioner(Rear side)	Apply grease between idler wheel and shaft. Check for wear, if worn replace. Replace the two (2) idler wheels every 1000 000.	Page 1.49 Item 4	Grease	Grease
Fold knife home position switch (SW 9)	Check function of switch. Adjust according to REP 3.14.		Check/Adj	Check/Adj
Outfeed sensor	Use compressed air to clean the sensor and LED. Use an alcohol to clean the outfeed bracket from ink. Adjust the sensor according to REP 3.4.		Clean/Adj	Clean/Adj
Output transport belt	Clean with a rubber reactivator alcohol fluid.	Page 1.53 Item 12	Clean	Check/ Replace
Side jogger motor off switch (SW 4)	Check function of the switch. Adjust according to REP 3.10.	Page 1.15 Item 10	Check/Adj	Check/Adj
Stapler/Clincher motor on switch (SW 5)	Check function of the switch. Adjust according to REP 3.11.	Page 1.15 Item 10	Check/Adj	Check/Adj

Infeed module removed

Side jogger format mechanism	Apply grease on the threaded part of the shaft. Use oil on the flanged bushing.	Page 1.19 Item 3	Grease/Oil	Grease/Oil
Side jogger chain assembly	Apply chain oil. Check for wear, if worn replace.	Page 1.19 Item 8	Grease	Grease
Side jogger channel centering	Apply grease on the 3 gears and check adjustment according to REP 5.11.	Page 1.19 Item 15	Grease	Grease
Side jogger push rod centering	Apply oil between Side jogger push rod and flanged bushing. Check adjustment according to REP 5.12.	Page 1.17 Item 3	Oil	Oil
Side guide parallelism	Check that the side guides are parallel.		Check	Check
Side jogger adjustment sensor (SEN 2)	Use compressed air. Adjust according to REP 3.2.	Page 1.19 Item 10	Clean/Adj	Clean/Adj
Infeed transport belt	Clean with a rubber reactivator alcohol fluid. Check for wear. If worn, replace, acc to REP 6.2.	Page 1.7 Item 17	Clean	Clean
Infeed motor O-ring	Clean with a rubber reactivator alcohol fluid. Replace every 500 000 set, acc to REP 6.1.	Page 1.9 Item 5	Clean	Replace
Infeed sensor (SEN 6)	Use compressed air to clean the sensor.	Page 1.13 Item 16	Clean/Adj	Clean/Adj
Adjustment sensor (SEN 3)	Use compressed air to clean the sensor. Adjust according to REP 3.3.	Page 1.13 Item 11	Clean/Adj	Clean/Adj
Back jogger solenoid (SOL 6)	Check for wear, if worn replace. Replace every 1000 000, acc to REP 4.2.	Page 1.13 Item 14		Check/ Replace
Eject drive traction o-ring	Use a rubber reactivator alcohol fluid. Replace the motor o-ring every 500 000 set, acc to REP 5.9.	Page 1.35 Item 15	Clean	Replace

FINAL CHECK POINTS

Booklet quality	Check the booklet quality. The booklet should be evenly folded and both staples should be placed in the centre of the spine.		Check	Check
-----------------	--	--	-------	-------