

# *OPERATING INSTRUCTIONS*



***HyPro-6 USA***

***HyPro-8 USA***

***R-16, R-CAN***

***Compact-M, Compact-V***

Receiver Type / Version  
Factory No.  
Frequency

Transmitter Type / Version  
Factory No.  
Frequency

## 1. STANDARD SPECIFICATION

- Portable transmitter.
- Receiver with integrated mounting holes.
- Optional: Multi-pin connecting cable for the receiver according to your specifications.

The actual delivery specification is as detailed on the confirmation of order or the delivery note accompanying the goods!

## 2. SAFETY PRECAUTIONS

Even if you are accustomed to working with radio control systems, read these operating instructions carefully before using this equipment. Only this document contains the latest information relating to your NBB radio control system.

For explanatory notes on obtaining an operating permit please refer to registration documents enclosed in the appendix of this operating instruction. Observe all applicable work-safety and accident prevention regulations carefully. Only fully trained, authorized personnel may use the NBB radio control equipment. Components, etc. built into the NBB equipment for safety purposes must be regularly inspected.

If the NBB radio control unit develops a fault, it must be shut down immediately. The transmitter should be switched off with the STOP key, resp. EMERGENCY STOP switch. The connecting cable must be disconnected at the receiver from the connecting socket (terminal) of the unit to be controlled. The repair of the equipment must not be carried out other than by NBB or an NBB authorized technician.

Failure to observe these recommendations will put both you yourself and others at risk. Under these circumstances, NBB rescinds the guarantee and any other form of liability. This radio control unit is designed exclusively for the control of construction machines and industrial plants. Only under these conditions are the safety systems (STOP, resp. EMERGENCY STOP, zero setting) fully effective. No other form of use is permitted. Any non-observance of this condition will relieve NBB of all liability.

## 3. TRANSMITTER

Switching on: To make the unit ready for use, unscrew the screw plug of the battery compartment on the back of the transmitter and remove the cover. Insert 2 charged AA Mignon batteries 1,2V NiMH (or batteries 1,5V - not rechargeable) into the battery Compartment, close the cover and tighten the screw plug again.

Rechargeable batteries (NiMH or NiCd) must be fully charged before first use!

Never attempt to charge standard non rechargeable 1,5V AA batteries!

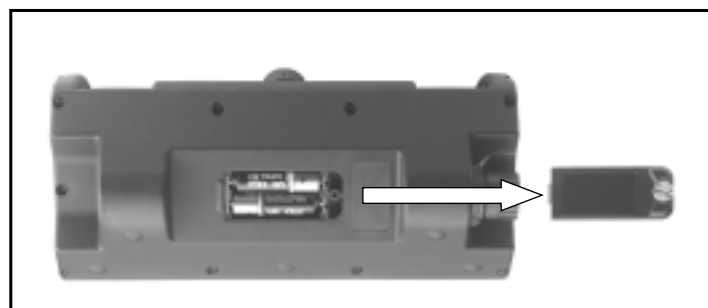
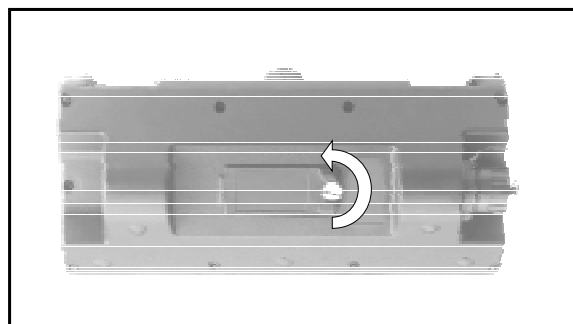

### 3. TRANSMITTER HyPro

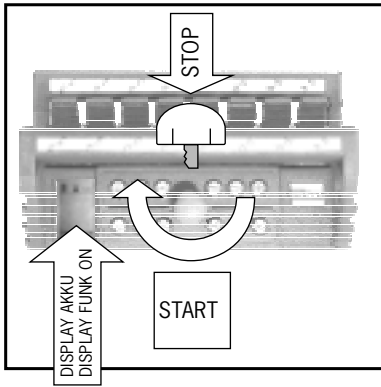

The power supply to the transmitter is activated with the "STOP" key, resp. EMERGENCY STOP switch.

(When pressed, the EMERGENCY STOP switch can also be secured by removing the key cap.)

The green LED on the transmitter control panel must flash regularly.

Commands can now be put in by means of the controls.

When the red "Battery" indicator lamp lights up, the batteries (rechargeable or not rechargeable) are nearly empty.

The transmitter can be operated for approximately 30 minutes more in this condition. During this time, bring the unit to a safe position, switch off the transmitter and install 2 charged AA Mignon batteries 1,2V NiMH (or batteries 1,5V - not rechargeable).

Energy saving function: The transmitter switches off automatically, if the keys are not pressed within a specified time. The LED goes out.

Optional: Transmitter for continuous operation possible.

*\*The duration of this stand-by can be specified when ordering.*

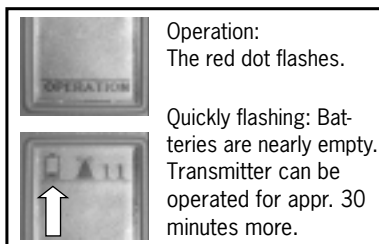
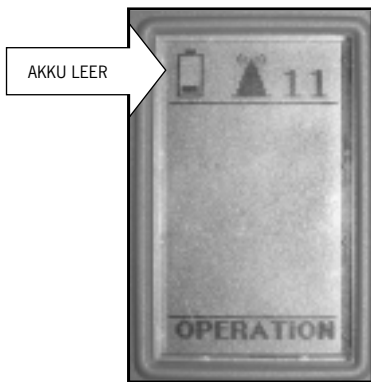

4. RECEIVER  
 R-16, R-CAN  
 Compact-M, Compact-V

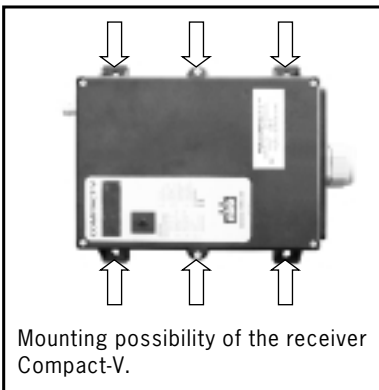
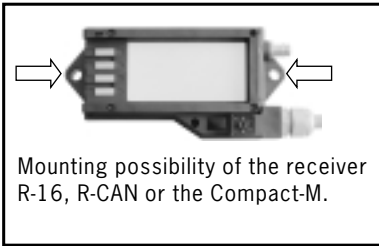
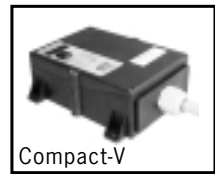

The receiver is connected to the unit to be controlled with the multi-pin connecting cable supplied. Please observe the instructions issued by the manufacturer of the unit to be controlled! We recommend urgently to realize this connection via a central, well accessible, multi-pin plug connector (for example HTS-plug connector series HE/HB/HN/HA or comparable ones of other manufacturers) to make possible a quick and clear fault diagnosis in the service case and to take off the receiver without an expenditure of assembly.

The power supply of the receiver is generally effected by the connecting cable.

- In general, an earth lead is required in case the units to be controlled have not previously been operated by radio control. Failing this, the receiver electronic circuit will not receive any power supply. Ensure that the operating voltage of the receiver complies with the electrical specifications of the unit to be controlled. The applicable operating voltage is specified in the supplement.
- Never expose the receiver to a high pressure cleaning jet. This applies to the transmitter also.
- The receiver should always be fixed vertically at the outside panel of the switching cabinet. (The antenna should always reach over the top of the panel.)
- You have to make sure that the antenna is not shielded by metal parts totally or partly.
- Mounting the receiver in a cabine or in a switching cabinet the antenna should be layed with an extension cable to the outside and be attached with the fastening strapping as horizontally as possible with distance to the shielding metal parts.
- In general the antenna should always be mounted in such a way so that the antenna is still visible with each change of position of the transmitter.

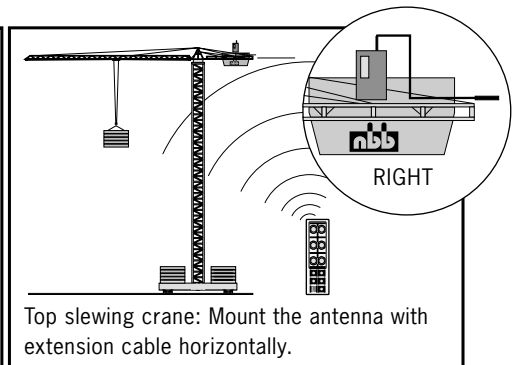
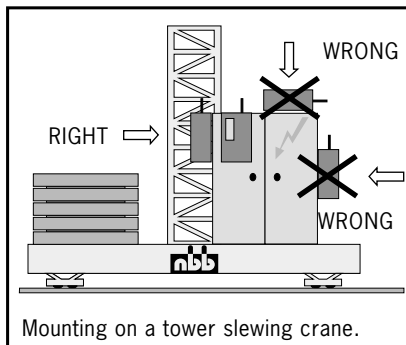

## 5. OPERATING THE UNIT

Safety equipment in the NBB-radio remote control:

In the transmitter, this comprises mainly:

- STOP, resp. EMERGENCY STOP with automatic disconnection of the power supply.
- Automatic zero positioning.

In the receiver:

- Two diversity units for evaluation of the STOP, resp. EMERGENCY STOP signal.
- Automatic zero setting when switching back on after radio interruption.
- Locking of the radio commands at relay level in the event of a defective STOP, resp. EMERGENCY STOP circuit.

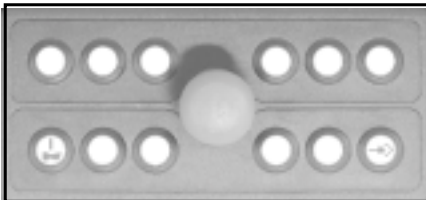

To ensure fault-free operation, please follow precisely the following rules for operation: The unit to be controlled can only be switched on - it is assumed that the transmitter is ready to operate - when no command unit is actuated. The command necessary to do so is triggered by the key "ON/HORN". This triggers a horn signal in the unit to be controlled. After switch-on of the facility to be controlled, this key is used for repeated emission of the horn signal in accordance with working regulations.

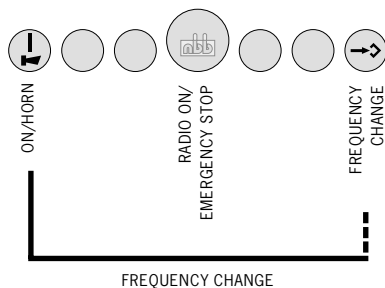

If the NBB radio remote control is not used for a long period, it is urgently recommended - if you use rechargeable batteries - that they should be charged now and again (about every 4 weeks). This prevents deep discharges of the batteries and prolongs their useful life. If you shut down the NBB radio remote control for a long period, we recommend you take the batteries out of the transmitter.

Frequency change:

To change the frequency, keep the "ON/HORN" key pressed down. Then operate the "FREQUENCY CHANGE" key. If the receiver locks into the new frequency, a horn signal is given (if present) and the unit to be controlled is ready for operation.

Please observe the particular postal approval regulations of the concerned country.

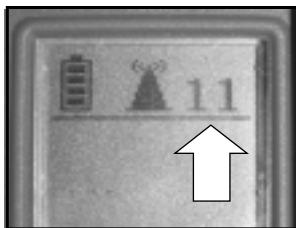

Channel number: When changing the frequency the channel number lights up in the display (HyPro). During operation the chosen channel can be shown by pressing the "FREQUENCY CHANGE" key. (See example on the left)

1

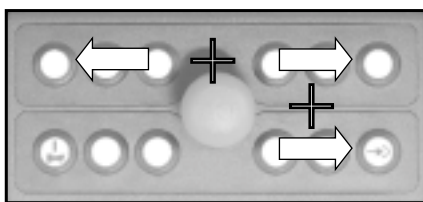

Teach In: "ON/HORN" once. The transmitter will go when exchanging one of the joysticks a "TEACH IN" has to be done: Push both outer buttons on the right side of the keypad as well as the outer button on the left side above and keep them pushed for seven (7) seconds. The display will say "JOY TEACH" and the command to fully stroke joysticks will appear. Move each joysticks all the way down and then all the way up. To exit the teach mode center all joysticks and push the button back to the normal operational mode.

2



3

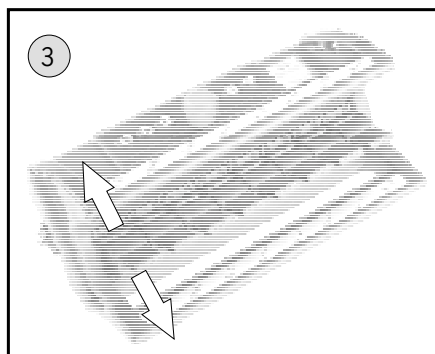

4

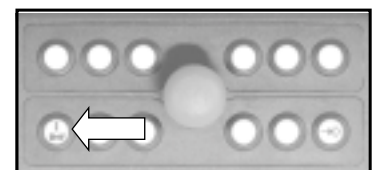

## 6. FUNCTION CHECK

To maintain operational safety, a regular function check of the NBB radio remote control is necessary. In single-shift day-to-day operation, we recommend performing this check at least once a week. Checking is possible using the display lights provided on the receiver. To do so, the transmitter must be set to the ready-to-operate state.

- First connect just the receiver - the transmitter remains switched off.
- Activate the transmitter by unlocking the EMERGENCY STOP switch, resp. pressing the key "START/ON/HORN".
- Now check the commands (always start with the lowest stage) and check for correct reaction of the unit to be controlled.
- Ensure in particular that there is nobody in the danger area. ACCIDENT RISK!
- STOP, resp. EMERGENCY STOP check. Press the EMERGENCY STOP switch at the transmitter until the switch engages, resp. press the STOP key. Then observe if the unit to be controlled is switched off (time to switch off according to the application).

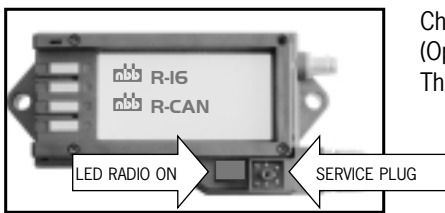

Checking the LED display at the receiver R-16 and R-CAN:  
(Optional with integrated charger)

- The green LED flashes: RADIO PRESENT.  
If the LED fails to come on:
1. Check that the transmitter is on.
  2. Check the power supply of the receiver.
  3. (Optional) Irregular flashing of the LED: Check or change the current radio channel.

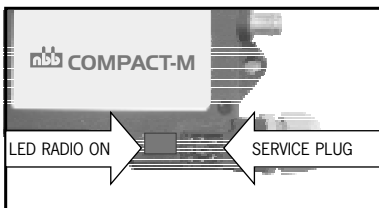

Checking the LED display at the receiver Compact-M:  
(Without integrated charger)

- The green LED flashes: RADIO PRESENT.  
If the LED fails to come on:
1. Check that the transmitter is on.
  2. Check the power supply of the receiver.
  3. (Optional) Irregular flashing of the LED: Check or change the current radio channel.

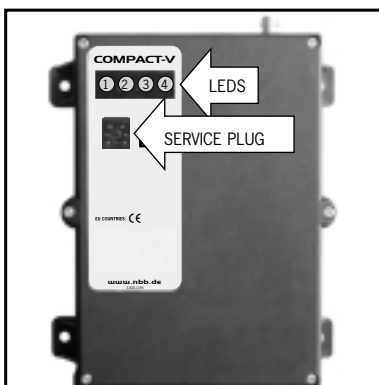

Checking the LED's at the receiver Compact-V:

- LED 1 green: POWER ON. If LED fails to come on, check the power supply. If the power lead is OK, call in the after-sales service.
- LED 2 yellow: HF PRESENT. Steady light when transmitter is switched on (insignificant for scanner operation).
- LED 3 green: Flashes evenly during fault-free operation. Irregular flashing means that the HF channel is probably at fault - please set another channel.
- LED 4 red: If this LED flashes, the HF channel is at fault (not in the scanner operation). Steady light notifies the operator that an output function is critical due to over current.

Service plug: For NBB service only.

## 7. RATING PLATES

The rating plates state the type of transmitter or receiver, the factory number, the frequency range and the approval number for non EU countries.  
Always state the factory number in all your queries.

Example:

**HyPRO** Serial-No.: **9993977591**  
**FCC: SJ7HYPRO43 IC:2634B-HYPRO43**  
This device complies with Part 15 of the FCC Rules. Operation is subject to the following two conditions: (1) this device may not cause harmful interference, and (2) this device must accept any interference received, including interference that may cause undesired operation.  
Freq.: 433,100-434,760 MHz 0507

## 8. MAINTENANCE

Your NBB radio remote control is largely maintenance-free. Nevertheless, please bear in mind the following points:

- The STOP key, resp.the EMERGENCY STOP switch must be easy to move.
- Remove any leftover building materials!
- During electro-welding work on the unit to be controlled, disconnect the receiver from the current supply! Otherwise there is a risk of damage to the receiver's electronic system!
- Check wear and tear parts like dust shield tops regular!

## 9. WARRANTY

We grant a function warranty for 12 months after the sale date for all NBB radio remote controls (transmitter, receiver, charger). The warranty covers working time and material used. Shipping costs shall be charged to the customer. The warranty shall not cover: wear and tear parts, relays and batteries. The function warranty shall be invalidated in the case of damage, accident damage, negligence, incorrect use, non-compliance with operating conditions, non-compliance with operating, testing and maintenance instructions, and repairs or unit modifications not authorised by NBB.

NBB shall not be liable for indirect damage and reserves the right to decide on repair or replacement.

## 10. IN CASE OF DEFECTS

Do not attempt to continue working with a defective NBB radio remote control. Even initially minor defects might be the start of a more extensive defect.

Do not try to repair the NBB radio remote control yourself. If there is any fault please contact your dealer or our company.

## 11. FCC



NOTE: This equipment has been tested and found to comply with the limits for a Class A digital device, pursuant to Part 15 of the FCC Rules. These limits are designed to provide reasonable protection against harmful interference when the equipment is operated in a commercial environment. This equipment generates, uses, and can radiate radio frequency energy and, if not installed and used in accordance with the instruction manual, may cause harmful interference to radio communications. Operation of this equipment in a residential area is likely to cause harmful interference in which case the user will be required to correct the interference at his own expense.



CAUTION: Changes or modifications not expressly approved by the manufacture could void the user's authority to operate the equipment.



Operating ambient temperature -20 to +70 °C  
 Insulation class - Protection IP 65

## TRANSMITTER HyPro-6, HyPro-8

Transmission frequency range 433.1 - 434.75 MHz (The actual frequency range depends on the regulations of the concerning country!)

The use of synthesizer technology permits frequencies to be selected in accordance with the appropriate waveband for the country of use.

Low frequency modulation GFSK  
 Data repetition rate about 15 ms / 60 ms  
 Baud rate 4800 Baud / 1200 Baud (Bit / sec.)  
 Range about 100 m  
 Power input about 60 mA  
 RF output < 10 mW

	Weight (without battery)	Size (L x W x H)
HyPro-6	1290 g	28,0 x 16,0 x 14,1 cm
HyPro-8	1350 g	28,0 x 16,0 x 14,1 cm

Power supply 2 x rechargeable batteries 1,2V AA NiMH  
 (or 2 x batteries 1,5V - not rechargeable)  
 Operating duration >30h (2000mA/h NiMH batteries)

## RECEIVER R-16, R-CAN, Compact-M, Compact-V

Reception frequency range 402 - 470 Mhz

### Data security:

Generates a CRC code with a Hamming distance = 4. Generates a neutral position.

Addressing of each transmitter with its own, unique combination (max.  $2^{16}$  possible combinations).

Data reception security: Diversity evaluators, CRC, EMERGENCY STOP and neutral position bits.

max. switching voltage 250V AC (12V / 24V DC - R-16, R-CAN, Compact-M, Compact-V)  
 max. switching current 4A AC (3A DC at 12V / 24V - R-16, R-CAN, Compact-M, Compact-V)  
 max. switching power 1000 VA

	Weight	Size (L x W x H)
R-16, R-CAN	640 g	18 x 9,7 x 4,4 cm
(potted)	800 g	
Compact-M	640 g	18 x 9 x 7 cm
(potted)	800 g	
Compact-V (potted)	1,5 kg	21,5 x 16 x 6,5 cm



Obtainable at demand:

M-Zert mbH

Certificate DIN EN ISO 9001:2000-12

No. 03022

© NBB Controls + Components AG  
Otto-Hahn-Straße 3-5  
DE-75248 Ölbronn-Dürrn  
Tel.: 0 72 37 / 9 99 - 0  
Fax: 0 72 37 / 9 99 - 1 99  
eMail: [sales@nbb.de](mailto:sales@nbb.de)  
<http://www.nbb.de>

We reserve the right to alter specifications without notice.



Bedienungsanleitung HyPro-6, HyPro-8, R-16, R-CAN, Compact-M, Compact-V,  
Englisch, Teile-Nr. 3.150.1251, Stand 11.06