

Small size 2.4GHz wireless transceiver module

「ZB24TM-E2036」

The ZB24TM-E2036 is a 2.4GHz Low power wireless transceiver module. The module contains all required hardware and software to evaluate and develop wireless communication based on IEEE 802.15.4 PHY.



Product Photo

< Feature >

- Integrated by MCU, RF circuits, antenna
- Equipped with a high performance pattern antenna.
- Communicated by the functions of device detect and data transmission
- Based on IEEE802.15.4.PHY
- 1:N communication style
- Controlled by UART I/F
- Low power sleep mode
- DC3.0V supply voltage
- Certified Japan Radio Law

<Block diagram>

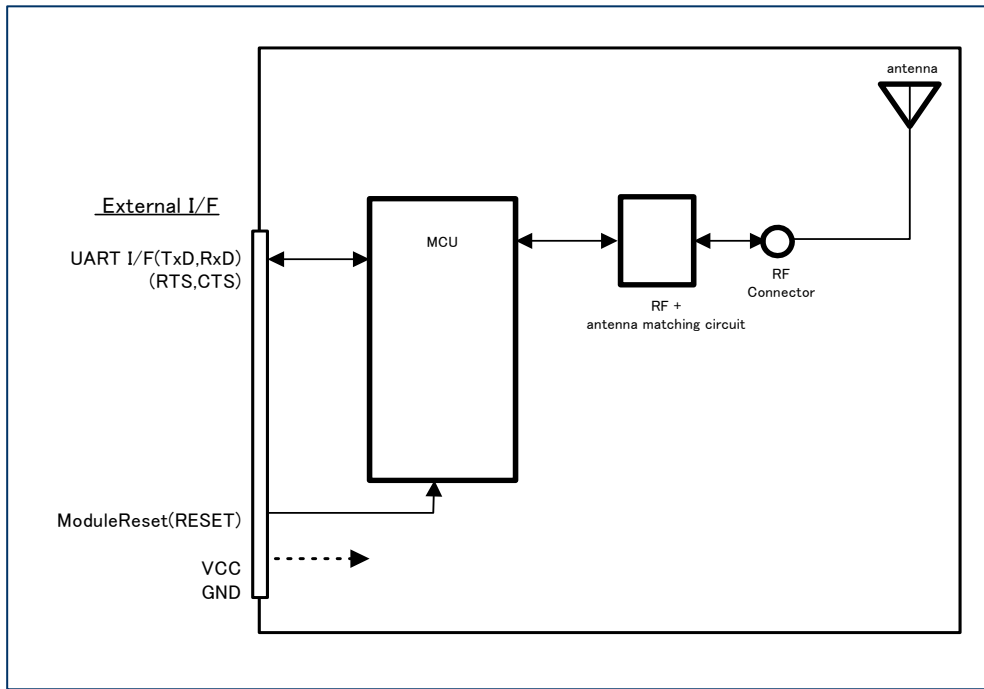

<Dimensions>

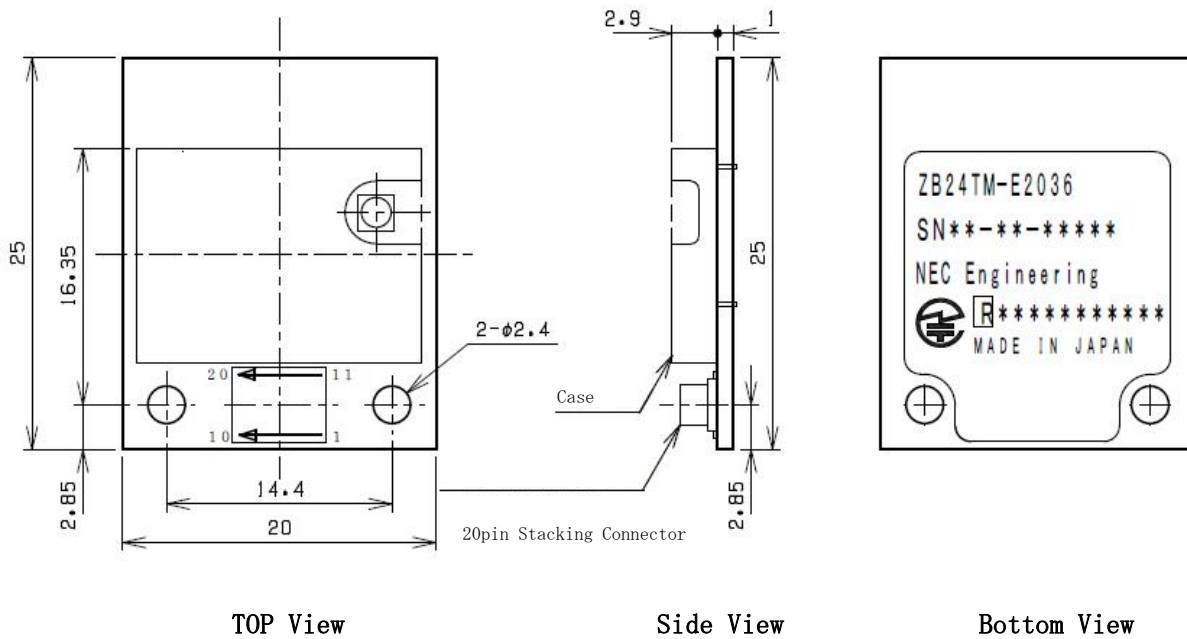

Unit:mm

<output I/F connector>

connector type : Stacking connector 20pin 0.5mm pitch
product name : JST 20R-JMCS-G-TF(NSA) Receptacle
Signal level : CMOS

Customer : Recommended connector
JST 20P3.0-JMCS-G-TF(N) Plug
Stacking height 3mm

-Module pin definitions

Pin No.	Pin name	Type	Definition	State of reset	Detail
1	VCC	power	Power	—	DC3.0V(Recommend power supply voltage)
2	GND	GND	GND	—	
3	TxD	OUT	UART data transmit	HiZ	
4	RxD	IN	UART data receive	HiZ	
5	WAKEUP	IN	WAKEUP input	—	Internal Pullup Sleep mode enable = High /disable = Low input
6	RESET	IN	RESET input	—	Internal Pullup RESET Low input
7	Reserved	—	Reserved	—	n.c
8	Reserved	—	Reserved	—	n.c
9	Reserved	—	Reserved	—	n.c
10	Reserved	—	Reserved	—	n.c
11	VCC	power	power	—	DC3.0V(Recommend power supply voltage)
12	GND	GND	GND	—	
13	GND	GND	GND	—	
14	CTS	—	Clear to send	—	n.c
15	RTS	—	Ready to send	—	n.c
16	Reserved	—	Reserved	—	n.c
17	Reserved	—	Reserved	—	n.c
18	Reserved	—	Reserved	—	n.c
19	MODE	OUT	Mode output	—	Normal mode = Low / sleep mode =High output
20	GND	GND	GND	—	

<Specification>

Product name	ZB24TM-E2036
Carrier frequency	2405MHz~2480MHz (16 channel)
Communication protocol	Original protocol
Modulation	DS-SS (Direct Sequence Spectrum Spread)
Wireless bit rate	Maximum 250Kbps (Subject to the communication environment)
Transmit Power	Maximum 3mW (At the feeding point of the antenna)
Outdoor RF line-of-sight Range	About 200m (Reference value)
Interface	-Serial communication Baud rate : Maximum 230.4kbps Data length: 8bit Parity: no parity Stop: 1stop bit Flow control: no flow control
Supply Voltage	-DC 3.0V (Recommended) -DC 2.1V~3.6V
Current Consumption	-TX: Typ. 35mA -RX: Typ. 28mA -Sleep Mode : Typ. 1uA (power-supply voltage DC 3.0V)
Operating conditions	-Operating temperature range:-20°C~+75°C -Operating humidity range:85%RH or less (No do be dewy)
Weight	About 2g
Dimensions	25mm×20mm×3.9mm (D×W×H)
Restrictions	RoHS-Compliant (Pb free)
Radio Law	Japan Radio Law certification

<FCC statement>

This device complies with Part 15 of the FCC Rules. Operation is subject to the following two conditions: (1) this device may not cause harmful interference, and (2) this device must accept any interference received, including interference that may cause undesired operation.

Modifications not expressly approved by NEC Engineering, Ltd. could void the user's authority to operate the equipment.

This equipment has been tested and found to comply with the limits for a Class B digital device, pursuant to Part 15 of the FCC Rules. These limits are designed to provide reasonable protection against harmful interference in a residential installation. This equipment generates, uses and can radiate radio frequency energy and, if not installed and used in accordance with the instructions, may cause harmful interference to radio communications. However, there is no guarantee that interference will not occur in a particular installation. If this equipment does cause harmful interference to radio or television reception, which can be determined by turning the equipment off and on, the user is encouraged to try to correct the interference by one or more of the following measures:

- Reorient or relocate the receiving antenna.
- Increase the separation between the equipment and receiver.
- Connect the equipment into an outlet on a circuit different from that to which the receiver is connected.
- Consult the dealer or an experienced radio/TV technician for help.

Radiofrequency radiation exposure Information:

The radiated output power of the device is far below the FCC radio frequency exposure limits. Nevertheless, the device shall be used in such a manner that the potential for human contact during normal operation is minimized.

Contact

NEC Engineering, Ltd.

General inquiries

Sales&Marketing Division

4-10-27 Higashishinagawa Shinagawa-ku Tokyo 140-0002 Japan

TEL: +81 3 6713 1200 URL <http://www.nec.co.jp/solution/engsl/pro/zigbee/>