

- Notes:
1. SD RX Waveguide Flange is not provided in HS/HS system.
 2. The TX/RX port orientation can be changed (see Section III).
 3. TX MON terminal on the BR CKT is optional.

TRP-L6/U6/10/11/24G-() All Indoor, 4 × TRP e/w FAN Type

Fig. 2-2 Outline of the TRP (3/4)

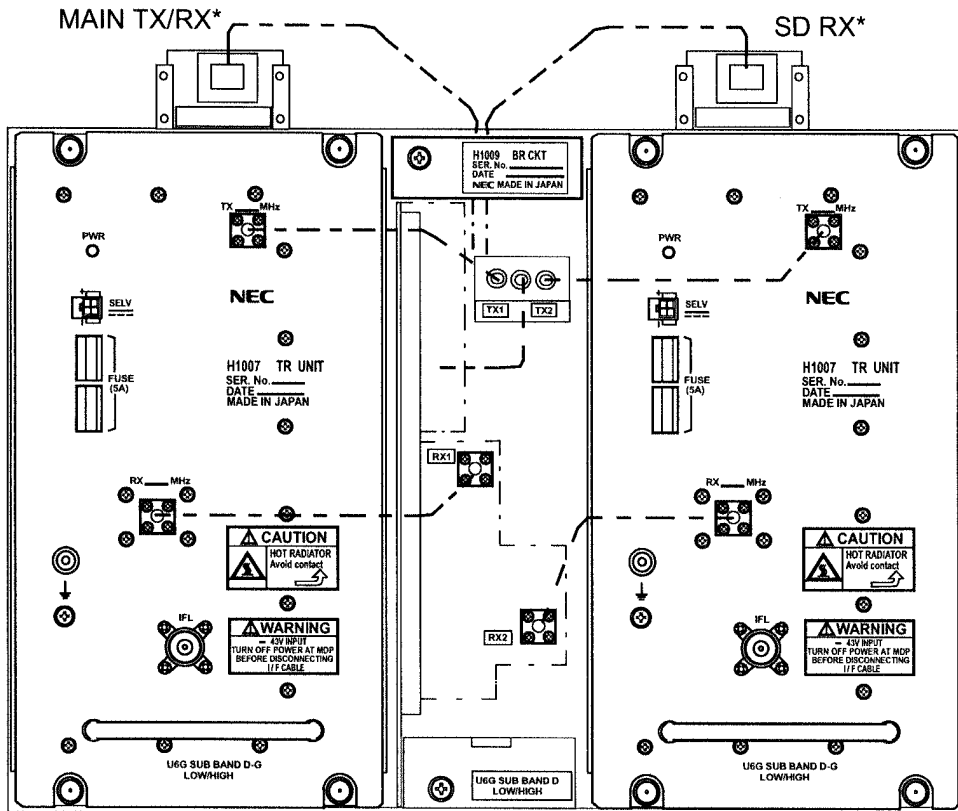

TRP (U6/11 GHz Band)**

Note: * In case of 1+1 Space Diversity when WG is connected from rear side.
 **The TRP face is illustrated as an example of U6 GHz band.

TRP-U6/11G-() All Indoor, 2 × TRP w/o FAN Type

Fig. 2-2 Outline of the TRP (4/4)

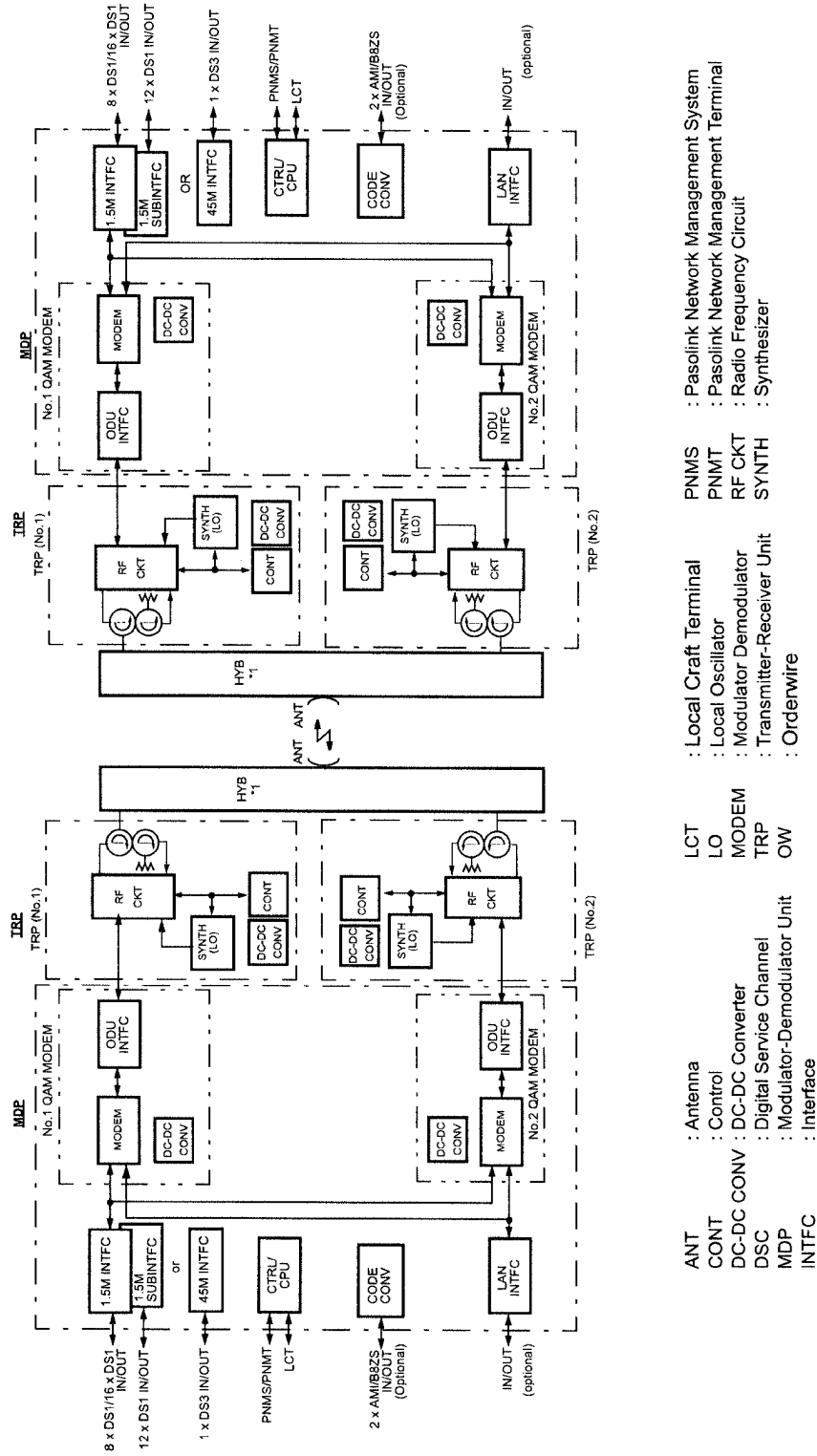

- ANT : Antenna
- CONT : Control
- DC-DC CONV : DC-DC Converter
- DSC : Digital Service Channel
- MDP : Modulator-Demodulator Unit
- INTFC : Interface
- LCT : Local Craft Terminal
- LO : Local Oscillator
- MODEM : Modulator Demodulator
- TRP : Transmitter-Receiver Unit
- OW : Orderwire
- PNMS : Pasolink Network Management System
- PNMT : Pasolink Network Management Terminal
- RF CKT : Radio Frequency Circuit
- SYNTH : Synthesizer

Note: The HYB (3 dB) or Directional Coupler (10 dB) type is used.

Fig. 2-3 HS/HS System for Split Type Block Diagram (Antenna Direct Mounting)

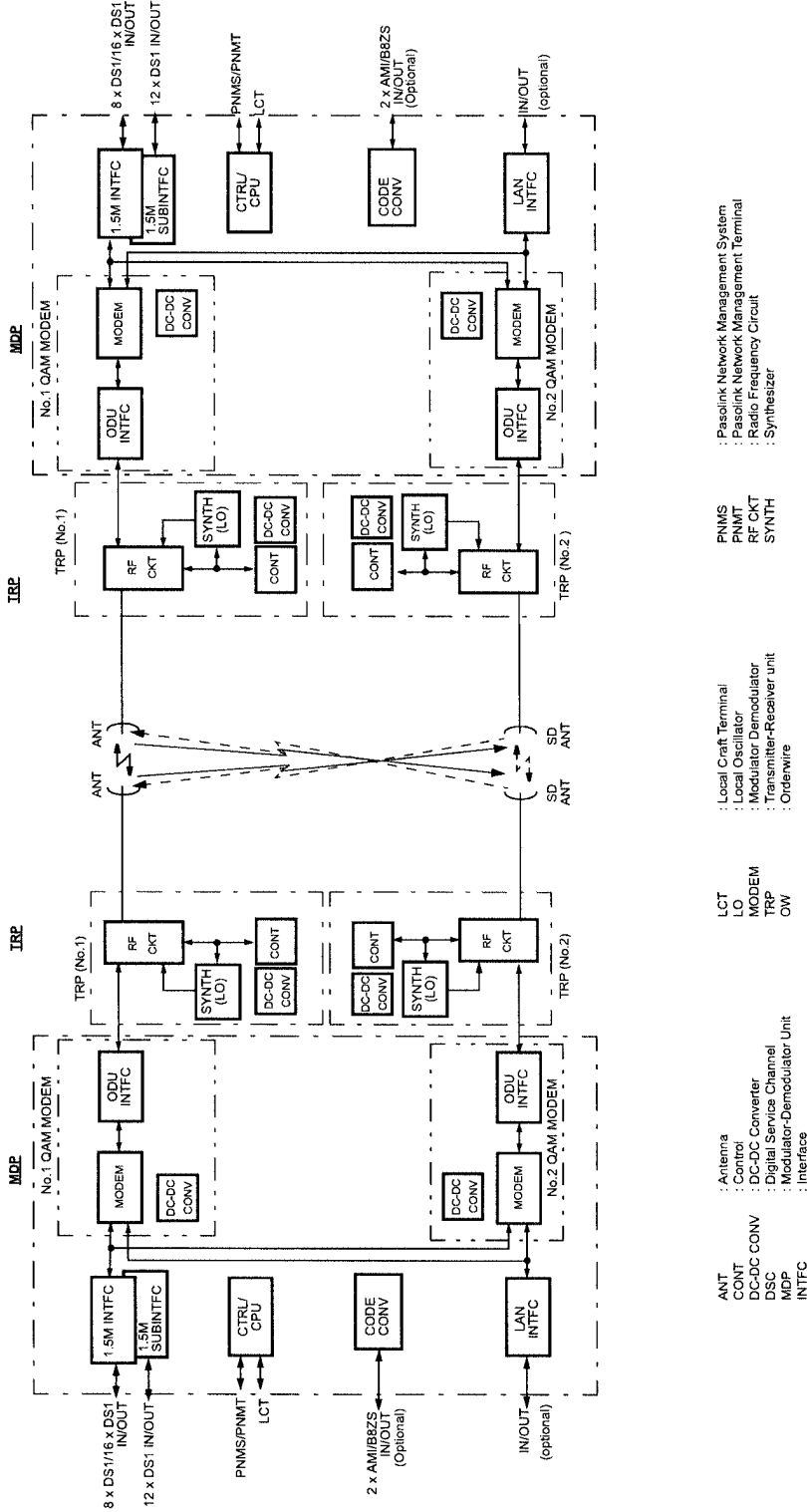
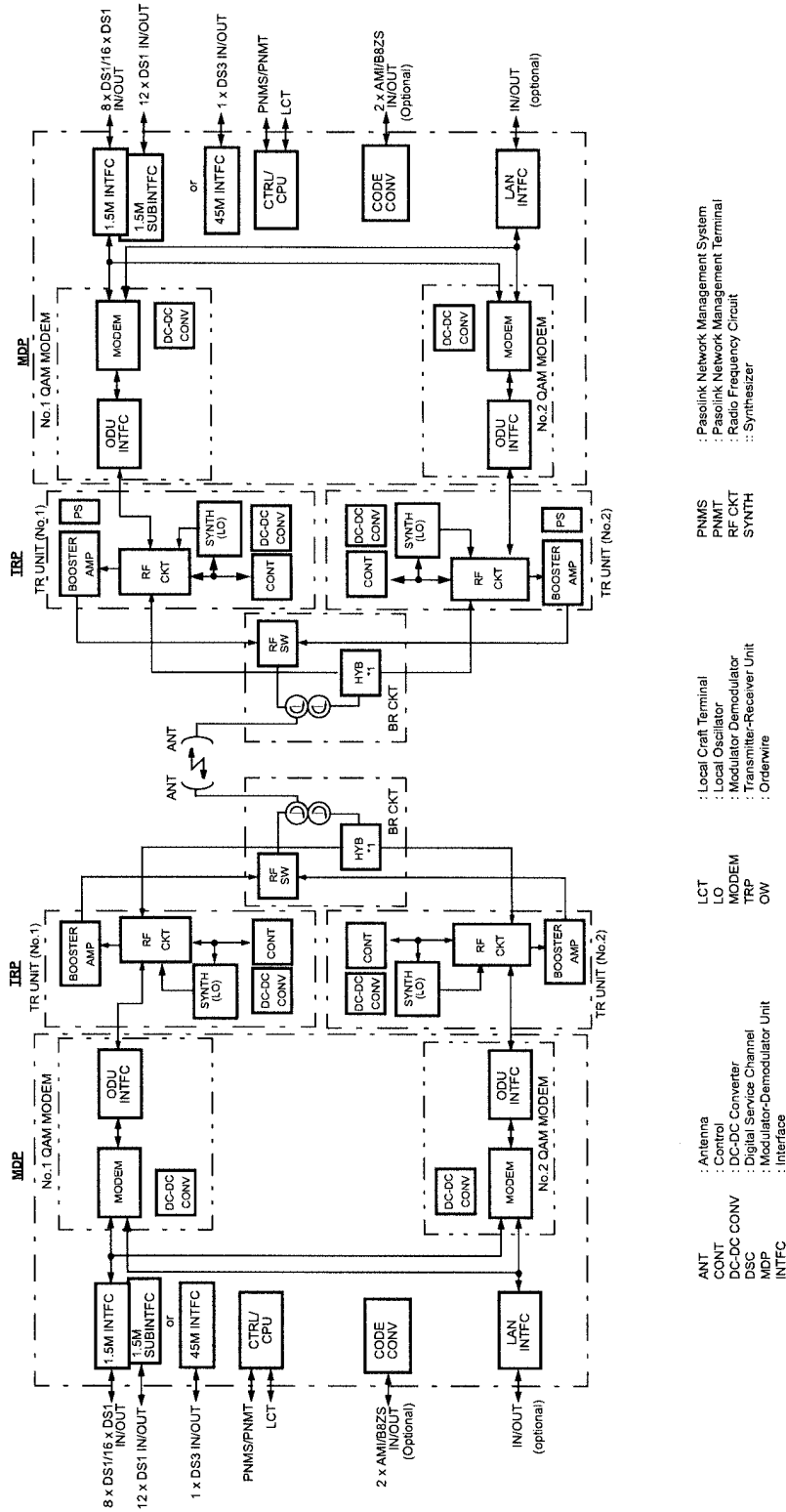

Fig. 2-4 HS/SD System for Split Type Block Diagram



- ANT : Antenna
- CONT : Control
- DC-DC CONV : DC-DC Converter
- DSC : Digital Service Channel
- MDP : Modem-Demodulator Unit
- INTFC : Interface
- LCT : Local Craft Terminal
- LO : Local Oscillator
- MODEM : Modem
- TRP : Transmitter-Receiver Unit
- OW : Orderwire
- PNMT : Pasalink Network Management Terminal
- RF CKT : Radio Frequency Circuit
- SYNTH : Synthesizer
- PS : Power Supply
- BOOSTER AMP : Booster Amplifier
- RF SW : Radio Frequency Switch
- HYB : Hybrid
- BR CKT : Branching Circuit
- DC-DC CONV : DC-DC Converter
- SYNTH (LO) : Synthesizer (Local Oscillator)
- MODEM : Modem
- ODU INTFC : Outdoor-Demodulator Interface
- MODEM : Modem
- DC-DC CONV : DC-DC Converter
- RF CKT : Radio Frequency Circuit
- PS : Power Supply
- BOOSTER AMP : Booster Amplifier
- IRE (No.1) : Indoor Radio Equipment (No.1)
- IRE (No.2) : Indoor Radio Equipment (No.2)
- MDE (No.1) : Modem-Demodulator Equipment (No.1)
- MDE (No.2) : Modem-Demodulator Equipment (No.2)
- LAN INTFC : LAN Interface
- ANM/B&ZS : Antenna Network Management System
- PNMIS/PNMT : Pasalink Network Management System / Pasalink Network Management Terminal
- CTR/CPU : Controller/Processor
- CODE CONV : Code Converter
- IN/OUT : Input/Output
- IN/OUT (optional) : Input/Output (optional)
- 8 x DS1/16 x DS1 IN/OUT : 8 x DS1/16 x DS1 Input/Output
- 12 x DS1 IN/OUT : 12 x DS1 Input/Output
- 1 x DS3 IN/OUT : 1 x DS3 Input/Output
- PNMIS/PNMT : Pasalink Network Management System / Pasalink Network Management Terminal
- LCT : Local Craft Terminal
- 2 x AMI/B&ZS IN/OUT (Optional) : 2 x AMI/B&ZS Input/Output (Optional)

Note: The HYB (3 dB) or Directional Coupler (10 dB) type is used.

Fig. 2-5 HS/HS System for All Indoor Type Block Diagram

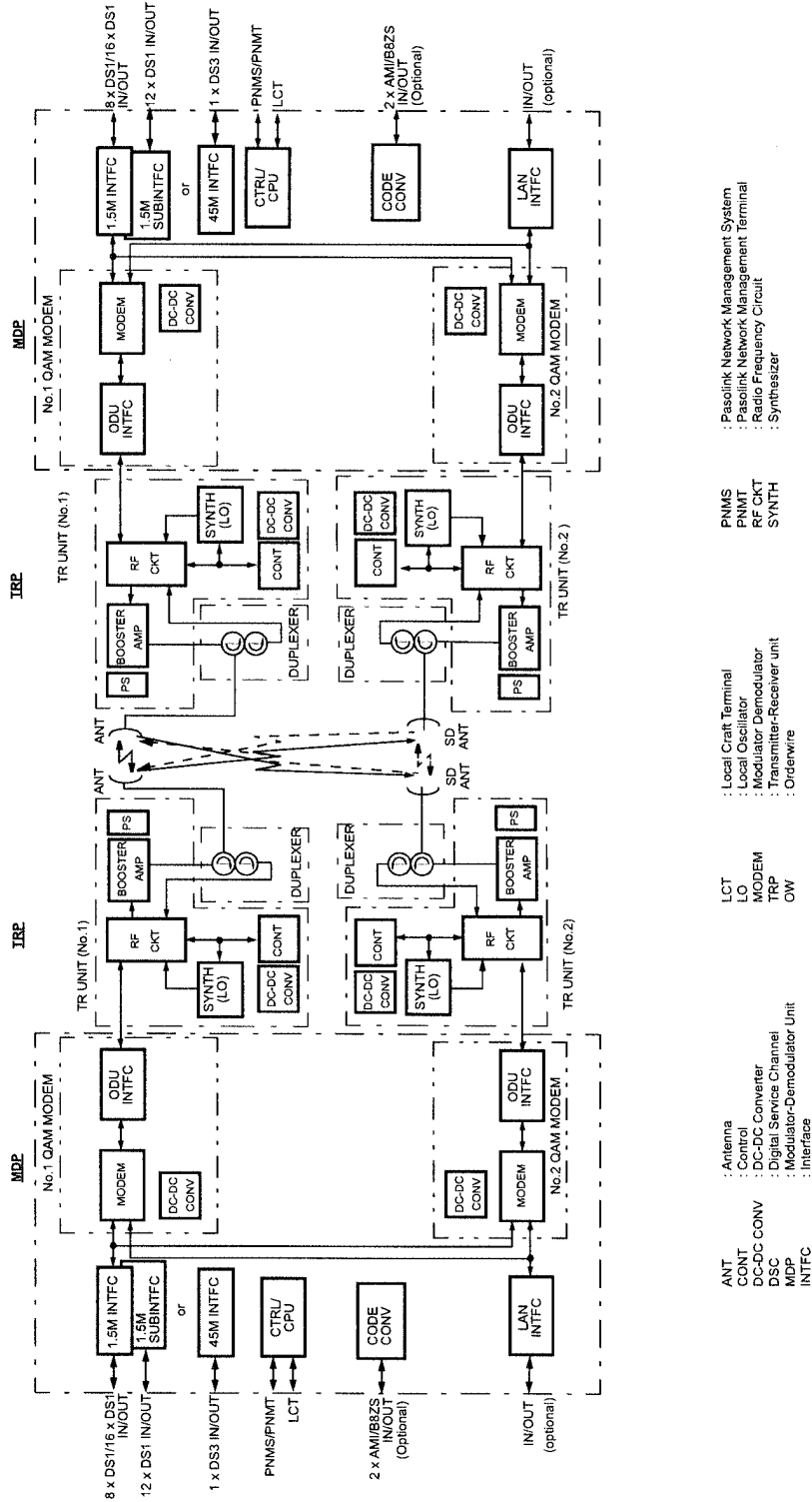

Fig. 2-6 HS/SD System for All Indoor Type Block Diagram

2.2 System Performance

The system performance characteristics of the 5.8/L6/U6/10.5/11/24 GHz 15/28/50 MB digital microwave radio system are listed in Table 2-3.

Table 2-3 System Performance (Typical Value)

A. Major Specification	
Transmission Signal	DS1 or DS3
Transmission Capacity	8 x 1.544 Mbps (8 x DS1)/ 16 x 1.544 Mbps (16 x DS1)/ 28 x 1.544 Mbps (28 x DS1) 1 x 45 Mbps (1 x DS3)
Modulation	32 QAM (for 8 x DS1)/ 128 QAM (for 16 x DS1) 64 QAM (for 28 x DS1/1 x DS3)
Demodulation	Coherent detection
Forward Error Correction (FEC)	RS
Equalizer	DFE
Data Interface	B8ZS or AMI for DS1/B3ZS for DS3 (ANSI T1, 107)
Impedance	
8 x DS1/16 x DS1 System:	100 ohms, balanced
1 x DS3 System:	75 ohms, unbalanced
Line length (selectable range)	
8 x DS1/16 x DS1/28 x DS1 System:	0-133 ft. (0-40m)/ 133-266 ft. (40-81m)/ 266-399 ft. (81-121m)/ 399-533 ft. (121-162m)/ 533-655 ft. (162-199m)
1 x DS3 System:	0-225 ft. (0-68m)/ 225-450 ft. (68-135m)
Signal Tolerance	
DS1: 1.544 MHz	
Input:	+/-130 ppm
Output:	+/-32 ppm
DS3: 44.736 MHz	
Input:	+/-20 ppm
Output:	+/-20 ppm

Table 2-3 System Performance (Typical Value) (Cont'd)

LAN Interface	
Standards Compliance :	IEEE 802.3 (10 Base-T/100 Base-TX)
Network Port :	10BASE-T/100BASE-TX × 2 Port
Function :	Auto Negotiation, Auto MDI/MDIX, effective 1K MAC Address Table, automatically learning and aging Maximum frame size 1548 bytes Conformed to IEEE 802.3x, Pause Frame Flow Control, effective (Full Duplex) Half Duplex Back Pressure, effective Link Loss Forwarding
Wayside signal Interface (optional in 28 x DS1/1 x DS3 System)	B8ZS or AMI (ANSI T1, 107)
Wayside signal Interface Impedance	100 ohms, balanced
Wayside signal Line length (selectable range)	0-133 ft. (0-40m)/ 133-266 ft. (40-81m)/ 266-399 ft. (81-121m)/ 399-533 ft. (121-162m)/ 533-655 ft. (162-199m)
Service Channel (*2)	
• EOW	1 CH
• RS-232C (*1)	1 CH
• V.11 (*1)	2 CH
(*1) Allows simultaneous use within 2 CHs from 3 CHs (V.11 + RS-232C).	
TX Power Control	
ATPC	0 to -20 dB (1 dB step)
MTPC	0 to -20 dB (1 dB step)
TX Switching System	RF Output Power Relay Switch (RF SW) for the TRP (HS/HS or HS/SD) of Indoor Type
RX Switching System	Hitless switch
Switching Range	Dynamic
Delay Equalization Range	more than +/-250 ns in total
Switching Criteria	Remote and Auto (F ASYNC ALM, LOW BER ALM)
Loopback Function	Main Signal Loopback (Far End, CH by CH basis) Main Signal Loopback (Near End, CH by CH basis) IF Signal Loopback (MODEM loop back)
Performance Monitoring	BBE, ES, SES, UAS, OFS (total)
Measurement	TX power level, RSL, BER
Alarm Output	Relay contact (Form-C); 7 outputs usable, 4 outputs fixed

Table 2-3 System Performance (Typical Value) (Cont'd)

Housekeeping Alarms (*1)	
Output	Relay contact (Form-C) 4 Items
Input	Photo-coupler; 2 inputs usable, 4 inputs for TRP FAN ALM fixed
Supervision	
LCT	RS-232C interface
PNMT	RS-232C interface
PNMS	10BASE-T/V.11
TX Power Control	
ATPC	0 to -20 dB (1 dB step)
MTPC	0 to -20 dB (1 dB step)
RX Switching System	Hitless switch
Switching Range	Dynamic
Delay Equalization Range	more than +/-250 ns in total
Switching Criteria	Remote and Auto (F ASYNC ALM, LOW BER ALM)
Loopback Function	Main Signal Loopback (Far End, CH by CH basis) Main Signal Loopback (Near End, CH by CH basis) IF Signal Loopback (MODEM loop back)
Performance Monitoring	BBE, ES, SES, UAS, OFS (total)
Measurement	TX power level, RSL, BER
Alarm Output	Relay contact (Form-C); 7 outputs usable, 4 outputs fixed
Housekeeping Alarms (*1)	
Output	Relay contact (Form-C) 4 Items
Input	Photo-coupler; 2 inputs usable, 4 inputs for TRP FAN ALM fixed
Supervision	
LCT	RS-232C interface
PNMT	RS-232C interface
PNMS	10BASE-T/V.11

Notes: *1 Output:

Rated Current is 0.2 A
Maximum Voltage 100 V (AC+DC)

Input:

Open > 200 kohms
Closed < 50 ohms

Table 2-3 System Performance (Typical Value) (Cont'd)

B. System Parameter (for Split Type)

Item		Specification				Condition/ Remarks
Transmission Capacities		8 x DS1	16 x DS1	28 x DS1	1 x DS3	
Transmit Power	5.8 GHz	+25.0 dBm	+25.0 dBm	+25.0 dBm	+25.0 dBm	Typical, At TR UNIT OUT
	L6 GHz	+25.0 dBm	+25.0 dBm	+25.0 dBm	+25.0 dBm	
	U6 GHz	+25.0 dBm	+25.0 dBm	+25.0 dBm	+25.0 dBm	
	10.5 GHz	+21.0 dBm	+21.0 dBm	—	—	
	11 GHz	—	—	—	+21.5 dBm	
	24 GHz	—	—	+18.0 dBm	+18.0 dBm	
RSL (at 10-6)	5.8 GHz	-85.5 dBm	-77.0 dBm	-73.5 dBm	-73.5 dBm	Typical, Including HYB CKT loss
	L6 GHz	-86.5 dBm	-78.0 dBm	-76.5 dBm	-76.5 dBm	
	U6 GHz	-86.5 dBm	-78.0 dBm	-76.5 dBm	-76.5 dBm	
	10.5 GHz	-84.0 dBm	-75.5 dBm	—	—	
	11 GHz	—	—	—	-74.5 dBm	
	24 GHz	—	—	-74.5 dBm	-74.5 dBm	
System Gain	5.8 GHz	110.5 dB	102.0 dB	98.5 dB	98.5 dB	@ 10-6 Guarantee -3 dB
	L6 GHz	111.5 dB	103.0 dB	101.5 dB	101.5 dB	
	U6 GHz	111.5 dB	103.0 dB	101.5 dB	101.5 dB	
	10.5 GHz	105.0 dB	96.5 dB	—	—	
	11 GHz	—	—	—	96.0 dB	
	24 GHz	—	—	92.5 dB	92.5 dB	
Maximum Input Level	@10 ⁻³	-17 dBm				
	@10 ⁻⁶	-21 dBm				

Table 2-3 System Performance (Typical Value) (Cont'd)

B. System Parameter (for All Indoor Type (e/w FAN))		Specification										Condition/Remarks		
Item														
Transmitting Output Power														
Transmission Capacities		8 x DS1			16 x DS1			28 x DS1/1 x DS3			BR CKT Type		Condition/Remarks	
Transmit Power		STD	HIGH	STD	HIGH	STD	HIGH	STD	HIGH	STD	HIGH			
L6 GHz	1+0	+30.5 dBm	+33.5 dBm	+30.5dBm	+33.5 dBm	+30.5 dBm	+33.5 dBm	+30.5 dBm	+33.5 dBm	+30.5 dBm	+33.5 dBm	L6 GHz Wide Band		At ANT Port
	HS/HS (HYB)	+30.3 dBm	+33.3 dBm	+30.3 dBm	+33.3 dBm	+30.3 dBm	+33.3 dBm	+30.3 dBm	+33.3 dBm	+30.3 dBm	+33.3 dBm			
	HS/HS (CPL)	+30.3 dBm	+33.3 dBm	+30.3 dBm	+33.3 dBm	+30.3 dBm	+33.3 dBm	+30.3 dBm	+33.3 dBm	+30.3 dBm	+33.3 dBm			
	HS/SD	+30.3dBm	+33.3 dBm	+30.3 dBm	+33.3 dBm	+30.3 dBm	+33.3 dBm	+30.3 dBm	+33.3 dBm	+30.3 dBm	+33.3 dBm			
	1+0	+29.5dBm	+32.5 dBm	+29.5dBm	+32.5 dBm	+29.5 dBm	+32.5 dBm	+29.5 dBm	+32.5 dBm	+29.5 dBm	+32.5 dBm	L6 GHz Narrow Band		
U6 GHz	HS/HS (HYB)	+29.5 dBm	+32.5 dBm	+29.5 dBm	+32.5 dBm	+29.5 dBm	+32.5 dBm	+29.5 dBm	+32.5 dBm	+29.5 dBm	+32.5 dBm	U6 GHz Narrow Band		
	HS/HS (CPL)	+29.5 dBm	+32.5 dBm	+29.5 dBm	+32.5 dBm	+29.5 dBm	+32.5 dBm	+29.5 dBm	+32.5 dBm	+29.5 dBm	+32.5 dBm			
	HS/SD	+29.5 dBm	+32.5 dBm	+29.5 dBm	+32.5 dBm	+29.5 dBm	+32.5 dBm	+29.5 dBm	+32.5 dBm	+29.5 dBm	+32.5 dBm			
	1+0	+29.5dBm	+32.5 dBm	+29.5dBm	+32.5 dBm	+29.5 dBm	+32.5 dBm	+29.5 dBm	+32.5 dBm	+29.5 dBm	+32.5 dBm			
	HS/HS (HYB)	+29.5 dBm	+32.5 dBm	+29.5 dBm	+32.5 dBm	+29.5 dBm	+32.5 dBm	+29.5 dBm	+32.5 dBm	+29.5 dBm	+32.5 dBm			
10.5 GHz	HS/HS (HYB)	—	+29 dBm	—	+29 dBm	—	+29 dBm	—	+29 dBm	—	+29 dBm	10.5 GHz Narrow Band		
	HS/HS (CPL)	—	+29 dBm	—	+29 dBm	—	+29 dBm	—	+29 dBm	—	+29 dBm			
	HS/SD	—	+29 dBm	—	+29 dBm	—	+29 dBm	—	+29 dBm	—	+29 dBm			
	1+0	—	+29 dBm	—	+29 dBm	—	+29 dBm	—	+29 dBm	—	+29 dBm			
	HS/HS (HYB)	—	+29 dBm	—	+29 dBm	—	+29 dBm	—	+29 dBm	—	+29 dBm			
11GHz	HS/HS (HYB)	—	—	—	—	—	—	—	—	—	—	11 GHz Narrow Band		
	HS/HS (CPL)	—	—	—	—	—	—	—	—	—	—			
	HS/SD	—	—	—	—	—	—	—	—	—	—			

Table 2-3 System Performance (Typical Value) (Cont'd)

Item		Specification												Condition/Remarks			
Received Signal Level RSL (@10 ⁻⁶)																	
Transmission Capacities		8 x DS1				16 x DS1				28 x DS1/1 x DS3				BR CKT Type		Condition/Remarks	
Transmit Power		STD	HIGH	STD	HIGH	STD	HIGH	STD	HIGH	STD	HIGH	STD	HIGH				
L6 GHz	1+0	-85.5 dBm	-85.5 dBm	-77.0 dBm	-77.0 dBm	-75.5 dBm	-75.5 dBm	-75.5 dBm	-75.5 dBm	-75.5 dBm	-75.5 dBm	-75.5 dBm	-75.5 dBm	L6 GHz Wide Band		@10 ⁻⁶ Typical at ANT Port	
	HS/HS (HYB)	-81.5 dBm	-81.5 dBm	-73.0 dBm	-73.0 dBm	-71.5 dBm	-71.5 dBm	-71.5 dBm	-71.5 dBm	-71.5 dBm	-71.5 dBm	-71.5 dBm	-71.5 dBm				
	HS/HS (CPL)	-84.5 dBm	-84.5 dBm	-76.0 dBm	-76.0 dBm	-74.5 dBm	-74.5 dBm	-74.5 dBm	-74.5 dBm	-74.5 dBm	-74.5 dBm	-74.5 dBm	-74.5 dBm				
	HS/SD	-85.5 dBm	-85.5 dBm	-77.0 dBm	-77.0 dBm	-75.5 dBm	-75.5 dBm	-75.5 dBm	-75.5 dBm	-75.5 dBm	-75.5 dBm	-75.5 dBm	-75.5 dBm				
	1+0	-84.5 dBm	-84.5 dBm	-76.0 dBm	-76.0 dBm	-74.5 dBm	-74.5 dBm	-74.5 dBm	-74.5 dBm	-74.5 dBm	-74.5 dBm	-74.5 dBm	-74.5 dBm				
	HS/HS (HYB)	-80.5 dBm	-80.5 dBm	-72.0 dBm	-72.0 dBm	-70.5 dBm	-70.5 dBm	-70.5 dBm	-70.5 dBm	-70.5 dBm	-70.5 dBm	-70.5 dBm	-70.5 dBm				
	HS/HS (CPL)	-83.5 dBm	-83.5 dBm	-75.0 dBm	-75.0 dBm	-73.5 dBm	-73.5 dBm	-73.5 dBm	-73.5 dBm	-73.5 dBm	-73.5 dBm	-73.5 dBm	-73.5 dBm				
	HS/SD	-84.5 dBm	-84.5 dBm	-76.0 dBm	-76.0 dBm	-74.5 dBm	-74.5 dBm	-74.5 dBm	-74.5 dBm	-74.5 dBm	-74.5 dBm	-74.5 dBm	-74.5 dBm				
	1+0	-84.5 dBm	-84.5 dBm	-76.0 dBm	-76.0 dBm	-74.5 dBm	-74.5 dBm	-74.5 dBm	-74.5 dBm	-74.5 dBm	-74.5 dBm	-74.5 dBm	-74.5 dBm				
	HS/HS (HYB)	-80.5 dBm	-80.5 dBm	-72.0 dBm	-72.0 dBm	-70.5 dBm	-70.5 dBm	-70.5 dBm	-70.5 dBm	-70.5 dBm	-70.5 dBm	-70.5 dBm	-70.5 dBm				
U6 GHz	HS/HS (CPL)	-83.5 dBm	-83.5 dBm	-75.0 dBm	-75.0 dBm	-73.5 dBm	-73.5 dBm	-73.5 dBm	-73.5 dBm	-73.5 dBm	-73.5 dBm	-73.5 dBm	-73.5 dBm	U6 GHz Narrow Band			
	HS/SD	-84.5 dBm	-84.5 dBm	-76.0 dBm	-76.0 dBm	-74.5 dBm	-74.5 dBm	-74.5 dBm	-74.5 dBm	-74.5 dBm	-74.5 dBm	-74.5 dBm	-74.5 dBm				
	1+0	-	-82.0 dBm	-	-73.5 dBm	-	-	-	-	-	-	-	-				
	HS/HS (HYB)	-	-77.0 dBm	-	-68.5 dBm	-	-	-	-	-	-	-	-				
	HS/HS (CPL)	-	-80.5 dBm	-	-72.0 dBm	-	-	-	-	-	-	-	-				
	HS/SD	-	-82.0 dBm	-	-73.5 dBm	-	-	-	-	-	-	-	-				
	1+0	-	-	-	-	-73.5 dBm	-73.5 dBm	-73.5 dBm	-73.5 dBm	-73.5 dBm	-73.5 dBm	-73.5 dBm	-73.5 dBm				
	HS/HS (HYB)	-	-	-	-	-68.5 dBm	-68.5 dBm	-68.5 dBm	-68.5 dBm	-68.5 dBm	-68.5 dBm	-68.5 dBm	-68.5 dBm				
	HS/HS (CPL)	-	-	-	-	-72.0 dBm	-72.0 dBm	-72.0 dBm	-72.0 dBm	-72.0 dBm	-72.0 dBm	-72.0 dBm	-72.0 dBm				
	HS/SD	-	-	-	-	-72.0 dBm	-72.0 dBm	-72.0 dBm	-72.0 dBm	-72.0 dBm	-72.0 dBm	-72.0 dBm	-72.0 dBm				
11GHz	1+0	-	-	-	-	-73.5 dBm	-73.5 dBm	-73.5 dBm	-73.5 dBm	-73.5 dBm	-73.5 dBm	-73.5 dBm	-73.5 dBm	11 GHz Narrow Band			
	HS/HS (HYB)	-	-	-	-	-68.5 dBm	-68.5 dBm	-68.5 dBm	-68.5 dBm	-68.5 dBm	-68.5 dBm	-68.5 dBm	-68.5 dBm				
	HS/HS (CPL)	-	-	-	-	-72.0 dBm	-72.0 dBm	-72.0 dBm	-72.0 dBm	-72.0 dBm	-72.0 dBm	-72.0 dBm	-72.0 dBm				
	HS/SD	-	-	-	-	-72.0 dBm	-72.0 dBm	-72.0 dBm	-72.0 dBm	-72.0 dBm	-72.0 dBm	-72.0 dBm	-72.0 dBm				

Table 2-3 System Performance (Typical Value) (Cont'd)

Item		Specification										Condition/Remarks					
System Gain																	
Transmission Capacities		8 x DSI			16 x DSI			28 x DSI/1 x DS3			BR CKT Type		Condition/Remarks				
Transmit Power		STD	HIGH	STD	HIGH	STD	HIGH	STD	HIGH	STD	HIGH						
L6 GHz	1+0	+116.0 dB	+119.0 dB	+107.5 dB	+110.5 dB	+106.0 dB	+109.0 dB	+106.0 dB	+109.0 dB			L6 GHz Wide Band	@10 ⁻⁶ Guarantee: -3 dB				
	HS/HS (HYB)	+111.8 dB	+114.8 dB	+103.3 dB	+106.3 dB	+101.8 dB	+104.8 dB	+101.8 dB	+104.8 dB								
	HS/HS (CPL)	+114.8 dB	+117.8 dB	+106.3 dB	+109.3 dB	+104.8 dB	+107.8 dB	+104.8 dB	+107.8 dB								
	HS/SD	+115.8 dB	+118.8 dB	+107.3 dB	+110.3 dB	+105.8 dB	+108.8 dB	+105.8 dB	+108.8 dB								
	1+0	+114.0 dB	+117.0 dB	+105.5 dB	+108.5 dB	+104.0 dB	+107.0 dB	+104.0 dB	+107.0 dB					L6 GHz Narrow Band			
	HS/HS (HYB)	+110.0 dB	+113.0 dB	+101.5 dB	+104.5 dB	+100.0 dB	+103.0 dB	+100.0 dB	+103.0 dB								
	HS/HS (CPL)	+113.0 dB	+116.0 dB	+104.5 dB	+107.5 dB	+103.0 dB	+106.0 dB	+103.0 dB	+106.0 dB								
	HS/SD	+114.0 dB	+117.0 dB	+105.5 dB	+108.5 dB	+104.0 dB	+107.0 dB	+104.0 dB	+107.0 dB								
	1+0	+114.0 dB	+117.0 dB	+105.5 dB	+108.5 dB	+104.0 dB	+107.0 dB	+104.0 dB	+107.0 dB						U6 GHz Narrow Band		
	HS/HS (HYB)	+110.0 dB	+113.0 dB	+101.5 dB	+104.5 dB	+100.0 dB	+103.0 dB	+100.0 dB	+103.0 dB								
	HS/HS (CPL)	+113.0 dB	+116.0 dB	+104.5 dB	+107.5 dB	+103.0 dB	+106.0 dB	+103.0 dB	+106.0 dB								
	10.5 GHz	HS/SD	+114.0 dB	+117.0 dB	+105.5 dB	+108.5 dB	+104.0 dB	+107.0 dB	+104.0 dB	+107.0 dB							
1+0		—	+111.0 dB	—	+102.5 dB	—	—	—	—			10.5 GHz Narrow Band					
HS/HS (HYB)		—	+106.0 dB	—	+97.5 dB	—	—	—	—								
HS/HS (CPL)		—	+109.5 dB	—	+101.0 dB	—	—	—	—								
HS/SD	—	+111.0 dB	—	+102.5 dB	—	—	—	—									
11GHz	1+0	—	—	—	—	—	—	—	—	+103.5 dB	+103.5 dB	11 GHz Narrow Band					
	HS/HS (HYB)	—	—	—	—	—	—	—	—	+98.5 dB	+98.5 dB						
	HS/HS (CPL)	—	—	—	—	—	—	—	—	+102.0 dB	+102.0 dB						
	HS/SD	—	—	—	—	—	—	—	—	+103.5 dB	+103.5 dB						
Maximum Input Level	@10 ⁻³	-17 dBm															
	@10 ⁻⁶	-21 dBm															

Table 2-3 System Performance (Typical Value) (Cont'd)

B. System Parameter (for All Indoor Type (w/o FAN))

Item		Specification			Condition/Remarks
Transmission Capacities		8 x DS1	16 x DS1	28 x DS1/ 1 x DS3	
Transmit Power					
U6 GHz	1+0	+28.5 dBm			Typical, at BR CKT OUT
	HS (HYB)	+28.3 dBm			
	HS (CPL)	+28.3 dBm			
	HS/SD	+28.3 dBm			
11 GHz	1+0	+25.5 dBm			
	HS (HYB)	+25.3 dBm			
	HS (CPL)	+25.3 dBm			
	HS/SD	+25.3 dBm			
RSL (at 10 ⁻⁶)					
U6 GHz	1+0	-86.5 dBm	-78 dBm	-76.5 dBm	Typical, Including BR CKT loss
	HS (HYB)	-82.6 dBm	-74.1dBm	-72.6 dBm	
	HS (CPL)*	-85.5 dBm	-77 dBm	-75.5 dBm	
	HS/SD	-86.5 dBm	-78 dBm	-76.5 dBm	
11 GHz	1+0	-84.5 dBm	-76 dBm	-74.5 dBm	
	HS (HYB)	-80.1 dBm	-71.6 dBm	-70.1 dBm	
	HS (CPL)*	-83.8 dBm	-75.3 dBm	-73.8 dBm	
	HS/SD	-84.5 dBm	-76 dBm	-74.5 dBm	
System Gain					
U6 GHz	1+0	115 dB	106.5 dB	105 dB	@10 ⁻⁶ Guarantee -3 dB
	HS (HYB)	110.9 dB	102.4 dB	100.9 dB	
	HS (CPL)*	113.8 dB	105.3 dB	103.8 dB	
	HS/SD	114.8 dB	106.3 dB	104.8 dB	
11 GHz	1+0	110 dB	101.5 dB	100 dB	
	HS (HYB)	105.4 dB	96.9 dB	95.4 dB	
	HS (CPL)*	109.1 dB	100.6 dB	99.1 dB	
	HS/SD	109.8 dB	101.3 dB	99.8 dB	
Maximum Input Level	U6/11 GHz	-17 dBm			@10 ⁻³
		-21 dBm			@10 ⁻¹⁰

Table 2-3 System Performance (Typical Value) (Cont'd)

C. OVERALL	
MDP-TRP Interconnection Cable (Type and Maximum Cable Length)	Single coaxial cable, 50 ohms impedance <ul style="list-style-type: none"> • 200 m (5D-FB coaxial cable or equivalent) • 300 m (8D-FB coaxial cable or equivalent) • 350 m (10D-FB coaxial cable or equivalent) • 450 m (12D-FB coaxial cable or equivalent)
Primary Voltage (Safety Extra-Low Voltage (SELV))	<ul style="list-style-type: none"> • -48 V DC (-36 to -60 V)/+48 V DC (+36 to +60 V) or • -20 to -60 V/+20 to +60 V
Power Consumption (MDP + TRP)	
<ul style="list-style-type: none"> • For 5.8/6/10.5/11/24 GHz Band (Split Type) 	230 W for 1+1 configuration 120 W for 1+0 configuration
<ul style="list-style-type: none"> • For U6 GHz Band • For 11 GHz Band (All Indoor w/o FAN Type) 	100 W 1+0 configuration, 195 W for 1+1 configuration 85 W 1+0 configuration, 165 W for 1+0 configuration
<ul style="list-style-type: none"> • For L6/U6/10.5/11 GHz Band (All Indoor e/w FAN Type) 	230 W STD Power Type/330 W HP Power Type for 1+1 configuration 120 W STD Power Type/170W HP Power Type for 1+0 configuration
Dimension	
MDP	
<ul style="list-style-type: none"> • 1+1 system 	482 mm (W) x 159 mm (H) x 300 mm (D) (19 in. (W) x 6.3 in. (H) x 11.8 in. (D)) (1+1 System)
<ul style="list-style-type: none"> • 1+0 system 	482 mm (W) x 88 mm (H) x 300 mm (D) (19 in. (W) x 3.5 in. (H) x 11.8 in. (D)) (1+0 System)
TRP Split Type	
<ul style="list-style-type: none"> • 5.8/L6/U6/24 GHz 	236 mm (W) x 236 mm (H) x 110 mm (D) (9.3 in. (W) x 9.3 in. (H) x 4.3 in. (D))
<ul style="list-style-type: none"> • 10.5/11 GHz 	240 mm (W) x 243 mm (H) x 136 mm (D) (9.5 in. (W) x 9.6 in. (H) x 5.4 in. (D))
TRP All Indoor Type (w/o FAN)	
<ul style="list-style-type: none"> • U6/11 GHz 	482 mm (W) x 382 mm (H) x 353 mm (D) (19 in. (W) x 15 in. (H) x 14 in. (D))
TRP All Indoor Type (e/w FAN)	
<ul style="list-style-type: none"> • L6/U6/10.5/11 GHz 	435 mm (W) x 310 mm (H) x 300 mm (D) * (17.1 in. (W) x 12.2 in. (H) x 9.7 in. (D)) * <i>Note *: Excluding front cover.</i>

Table 2-3 System Performance (Typical Value) (Cont'd)

Weight	
MDP	
• 1+1 system	Approx. 15 kg (33 lbs.), (Including optional module)
• 1+0 system	Approx. 9 kg (20 lbs.), (Including optional module)
TRP Split Type	
• 5.8/L6/U6/24 GHz	Approx. 3.5 kg (7.7 lbs.)
• 10.5/11 GHz	Approx. 5 kg (11 lbs.)
TRP All Indoor Type (w/o FAN)	
• U6/11 GHz	Approx. 27 kg (60 lbs.) (for 1+1 system)
TRP All Indoor Type (e/w FAN)	
• L6/U6/10.5/11 GHz	Approx. 22 kg (48.5 lbs.) (for 1+1 system)
Ambient Temperature	
Guaranteed Operation	
MDP/TRP	0°C to +50°C (32°F to 122°F)
Workable Operation	
MDP/TRP	-10°C to +55°C (14°F to 131°F)
Transport and Storage	
MDP/TRP	-40°C to +70°C (-40°F to 158°F)
Relative Humidity	Less than 90% at 50°C (122°F) (Non-condensing)
Altitude	Up to 4,000 m (13,000 ft.)

2.3 RF Channel Plan

The NLite L applies for the Radio frequencies as follows:

- FCC 5.8 GHz Band: 5725 to 5850 MHz
- FCC L6 GHz Band: 5925 to 6425 MHz
- FCC U6 GHz Band: 6515 to 6875 MHz
SRSP U6 GHz Band: 6425 to 7125 MHz
- FCC 10.5 GHz Band: 10550 MHz to 10680 MHz
- FCC 11 GHz Band: 10700 MHz to 11700 MHz
- FCC 24 GHz Band: 24250 MHz to 25250 MHz

The TX frequency must be assigned within the TX radio frequency sub-band of the RF CKT in the TR UNIT. The TX frequency is entered using the local craft terminal (LCT). Normally, the corresponding RX frequency is automatically set after the TX frequency is entered but for the 5.8/6/24 GHz band TR UNIT of split and L6/U6/10.5/11 GHz band Indoor type e/w FAN, the RX frequency is settable to other values.

The frequency spacing between adjacent channels should be taken more than the following values of bandwidth:

- 8 x DS1 system : 3.75 MHz
- 16 x DS1 system: 5 MHz
- 28 x DS1/1 x DS3 system: 10 MHz

5.8GHz (For Split Type)

Setable Frequency: 1.25 kHz step

Shift Freq. 77 MHz

Low Band		High Band		Subband
TX	RX	TX	RX	
5730.000 to 5743.000	5807.000 to 5820.000	5807.000 to 5820.000	5730.000 to 5743.000	A
5743.000 to 5755.000	5820.000 to 5832.000	5820.000 to 5832.000	5743.000 to 5755.000	B
5755.000 to 5768.000	5832.000 to 5845.000	5832.000 to 5845.000	5755.000 to 5768.000	C

Note: Assignable frequency for the 8DS1 system: between from the [lowest frequency + 1.875 MHz] to the [top frequency - 1.875 MHz] within corresponding band.

Assignable frequency for the 16DS1 system: between from the [lowest frequency + 2.5 MHz] to the [top frequency - 2.5 MHz] within corresponding band.

Assignable frequency for the 1DS3 system: between from the [lowest frequency + 5 MHz] to the [top frequency - 5 MHz] within corresponding band.

SYSTEM DESCRIPTION

ROI-S06300

L6GHz
Bandwidth 3.75 MHz
Shift Freq. 252.04 MHz

Low Band			High Band		
CH	TX	RX	CH	TX	RX
1	6111.364	6363.404	1'	6363.404	6111.364
2	6116.305	6368.345	2'	6368.345	6116.305
3	6121.247	6373.287	3'	6373.287	6121.247
4	6126.189	6378.229	4'	6378.229	6126.189
5	6131.130	6383.170	5'	6383.170	6131.130
6	6136.072	6388.112	6'	6388.112	6136.072
7	6141.014	6393.054	7'	6393.054	6141.014
8	6145.955	6397.995	8'	6397.995	6145.955
9	6150.897	6402.937	9'	6402.937	6150.897
11	6160.780	6412.820	11'	6412.820	6160.780
12	6165.722	6417.762	12'	6417.762	6165.722

L6GHz
Bandwidth 5 MHz
Shift Freq. 252.04 MHz

Low Band			High Band		
CH	TX	RX	CH	TX	RX
1	6110.75	6362.79	1'	6362.79	6110.75
2	6115.69	6367.73	2'	6367.73	6115.69
3	6120.63	6372.67	3'	6372.67	6120.63
4	6125.57	6377.61	4'	6377.61	6125.57
5	6130.51	6382.55	5'	6382.55	6130.51
6	6135.45	6387.49	6'	6387.49	6135.45
7	6140.40	6392.44	7'	6392.44	6140.40
8	6145.34	6397.38	8'	6397.38	6145.34
9	6150.28	6402.32	9'	6402.32	6150.28
10	6155.22	6407.26	10'	6407.26	6155.22
11	6160.16	6412.20	11'	6412.20	6160.16
12	6165.10	6417.14	12'	6417.14	6165.10

L6GHz
Bandwidth 10 MHz
Shift Freq. 252.04 MHz

Low Band			High Band		
CH	TX	RX	CH	TX	RX
1	5935.32	6187.36	1'	6187.36	5935.32
2	5945.20	6197.24	2'	6197.24	5945.20
3	5955.08	6207.12	3'	6207.12	5955.08
4	5964.97	6217.01	4'	6217.01	5964.97
5	5974.85	6226.89	5'	6226.89	5974.85
6	5984.73	6236.77	6'	6236.77	5984.73
7	5994.62	6246.66	7'	6246.66	5994.62
8	6004.50	6256.54	8'	6256.54	6004.50
9	6014.38	6266.42	9'	6266.42	6014.38
10	6024.27	6276.31	10'	6276.31	6024.27
11	6034.15	6286.19	11'	6286.19	6034.15
12	6044.03	6296.07	12'	6296.07	6044.03
13	6053.92	6305.96	13'	6305.96	6053.92
14	6063.80	6315.84	14'	6315.84	6063.80
15	6073.68	6325.72	15'	6325.72	6073.68
16	6083.57	6335.61	16'	6335.61	6083.57
17	6093.45	6345.49	17'	6345.49	6093.45
18	6103.33	6355.37	18'	6355.37	6103.33
19	6113.22	6365.26	19'	6365.26	6113.22
20	6123.10	6375.14	20'	6375.14	6123.10
21	6132.98	6385.02	21'	6385.02	6132.98
22	6142.87	6394.91	22'	6394.91	6142.87
23	6152.75	6404.79	23'	6404.79	6152.75
24	6162.63	6414.67	24'	6414.67	6162.63

SYSTEM DESCRIPTION

ROI-S06300

U6GHz (For All Indoor w/o FAN Type)
Bandwidth 3.75 MHz (for 15MB System)
Shift Freq. 160 MHz

Low Band			High Band			SUB BAND
CH	TX	RX	CH	TX	RX	
1	6585.625	6745.625	1'	6745.625	6585.625	A
2	6590.625	6750.625	2'	6750.625	6590.625	
3	6595.625	6755.625	3'	6755.625	6595.625	
4	6600.625	6760.625	4'	6760.625	6600.625	
5	6605.625	6765.625	5'	6765.625	6605.625	B
6	6610.625	6770.625	6'	6770.625	6610.625	
7	6615.625	6775.625	7'	6775.625	6615.625	
8	6620.625	6780.625	8'	6780.625	6620.625	
9	6625.625	6785.625	9'	6785.625	6625.625	C
10	6630.625	6790.625	10'	6790.625	6630.625	
11	6635.625	6795.625	11'	6795.625	6635.625	
12	6040.625	6800.625	12'	6800.625	6640.625	
13	6645.625	6805.625	13'	6805.625	6645.625	D
14	6650.625	6810.625	14'	6810.625	6650.625	
15	6655.625	6815.625	15'	6815.625	6655.625	
16	6660.625	6820.625	16'	6820.625	6660.625	E
17	6665.625	6825.625	17'	6825.625	6665.625	
18	6670.625	6830.625	18'	6830.625	6670.625	
19	6675.625	6835.625	19'	6835.625	6675.625	
20	6680.625	6840.625	20'	6840.625	6680.625	F
21	6685.625	6845.625	21'	6845.625	6685.625	
22	6690.625	6850.625	22'	6850.625	6690.625	
23	6695.625	6855.625	23'	6855.625	6695.625	
24	6700.625	6860.625	24'	6860.625	6700.625	G
25	6705.625	6865.625	25'	6865.625	6705.625	

U6GHz (For All Indoor e/w FAN Type)
Bandwidth 3.75 MHz (for 15MB System)
Shift Freq. 160 MHz

Low Band			High Band		
CH	TX	RX	CH	TX	RX
1	6545.625	6705.625	1'	6705.625	6545.625
2	6550.625	6710.625	2'	6710.625	6550.625
3	6555.625	6715.625	3'	6715.625	6555.625
4	6560.625	6720.625	4'	6720.625	6560.625
5	6565.625	6725.625	5'	6725.625	6565.625
6	6585.625	6745.625	1'	6745.625	6585.625
7	6590.625	6750.625	2'	6750.625	6590.625
8	6595.625	6755.625	3'	6755.625	6595.625
9	6600.625	6760.625	4'	6760.625	6600.625
10	6605.625	6765.625	5'	6765.625	6605.625
11	6610.625	6770.625	6'	6770.625	6610.625
12	6615.625	6775.625	7'	6775.625	6615.625
13	6620.625	6780.625	8'	6780.625	6620.625
14	6625.625	6785.625	9'	6785.625	6625.625
15	6630.625	6790.625	10'	6790.625	6630.625
16	6635.625	6795.625	11'	6795.625	6635.625
17	6040.625	6800.625	12'	6800.625	6040.625
18	6645.625	6805.625	13'	6805.625	6645.625
19	6650.625	6810.625	14'	6810.625	6650.625
20	6655.625	6815.625	15'	6815.625	6655.625
21	6660.625	6820.625	16'	6820.625	6660.625
22	6665.625	6825.625	17'	6825.625	6665.625
23	6670.625	6830.625	18'	6830.625	6670.625
24	6675.625	6835.625	19'	6835.625	6675.625
25	6680.625	6840.625	20'	6840.625	6680.625
26	6685.625	6845.625	21'	6845.625	6685.625
27	6690.625	6850.625	22'	6850.625	6690.625
28	6695.625	6855.625	23'	6855.625	6695.625
29	6700.625	6860.625	24'	6860.625	6700.625
30	6705.625	6865.625	25'	6865.625	6705.625
31	6710.625	6870.625	25'	6870.625	6710.625

SYSTEM DESCRIPTION

ROI-S06300

U6GHz (For Split Type)
Bandwidth 3.75 MHz (for 15MB System)
Shift Freq. 160 MHz

Low Band			High Band		
CH	TX	RX	CH	TX	RX
1	6545.625	6705.625	1'	6705.625	6545.625
2	6550.625	6710.625	2'	6710.625	6550.625
3	6555.625	6715.625	3'	6715.625	6555.625
4	6560.625	6720.625	4'	6720.625	6560.625
5	6565.625	6725.625	5'	6725.625	6565.625
6	6585.625	6745.625	1'	6745.625	6585.625
7	6590.625	6750.625	2'	6750.625	6590.625
8	6595.625	6755.625	3'	6755.625	6595.625
9	6600.625	6760.625	4'	6760.625	6600.625
10	6605.625	6765.625	5'	6765.625	6605.625
11	6610.625	6770.625	6'	6770.625	6610.625
12	6615.625	6775.625	7'	6775.625	6615.625
13	6620.625	6780.625	8'	6780.625	6620.625
14	6625.625	6785.625	9'	6785.625	6625.625
15	6630.625	6790.625	10'	6790.625	6630.625
16	6635.625	6795.625	11'	6795.625	6635.625
17	6040.625	6800.625	12'	6800.625	6040.625
18	6645.625	6805.625	13'	6805.625	6645.625
19	6650.625	6810.625	14'	6810.625	6650.625
20	6655.625	6815.625	15'	6815.625	6655.625
21	6660.625	6820.625	16'	6820.625	6660.625
22	6665.625	6825.625	17'	6825.625	6665.625
23	6670.625	6830.625	18'	6830.625	6670.625
24	6675.625	6835.625	19'	6835.625	6675.625
25	6680.625	6840.625	20'	6840.625	6680.625
26	6685.625	6845.625	21'	6845.625	6685.625
27	6690.625	6850.625	22'	6850.625	6690.625
28	6695.625	6855.625	23'	6855.625	6695.625
29	6700.625	6860.625	24'	6860.625	6700.625
30	6705.625	6865.625	25'	6865.625	6705.625

U6GHz (For All Indoor w/o FAN Type)
CH Separation 5 MHz
Bandwidth 5 MHz (for 28MB System)
Shift Freq. 160 MHz

Low Band			High Band			SUB BAND
CH	TX	RX	CH	TX	RX	
1	6585	6745	1'	6745	6585	A
2	6590	6750	2'	6750	6590	
3	6595	6755	3'	6755	6595	
4	6600	6760	4'	6760	6600	
5	6605	6765	5'	6765	6605	B
6	6610	6770	6'	6770	6610	
7	6615	6775	7'	6775	6615	
8	6620	6780	8'	6780	6620	
9	6625	6785	9'	6785	6625	C
10	6630	6790	10'	6790	6630	
11	6635	6795	11'	6795	6635	
12	6640	6800	12'	6800	6640	
13	6645	6805	13'	6805	6645	D
14	6650	6810	14'	6810	6650	
15	6655	6815	15'	6815	6655	
16	6660	6820	16'	6820	6660	E
17	6665	6825	17'	6825	6665	
18	6670	6830	18'	6830	6670	
19	6675	6835	19'	6835	6675	
20	6680	6840	20'	6840	6680	F
21	6685	6845	21'	6845	6685	
22	6690	6850	22'	6850	6690	
23	6695	6855	23'	6855	6695	
24	6700	6860	24'	6860	6700	G
25	6705	6865	24'	6865	6705	

SYSTEM DESCRIPTION

ROI-S06300

U6GHz (For All Indoor e/w FAN Type)
CH Separation 5 MHz
Bandwidth 5 MHz (for 28MB System)
Shift Freq. 160 MHz

Low Band			High Band		
CH	TX	RX	CH	TX	RX
1	6545	6705	1'	6705	6545
2	6550	6710	2'	6710	6550
3	6555	6715	3'	6715	6555
4	6560	6720	4'	6720	6560
5	6565	6725	4'	6725	6565
6	6585	6745	1'	6745	6585
7	6590	6750	2'	6750	6590
8	6595	6755	3'	6755	6595
9	6600	6760	4'	6760	6600
10	6605	6765	5'	6765	6605
11	6610	6770	6'	6770	6610
12	6615	6775	7'	6775	6615
13	6620	6780	8'	6780	6620
14	6625	6785	9'	6785	6625
15	6630	6790	10'	6790	6630
16	6635	6795	11'	6795	6635
17	6640	6800	12'	6800	6640
18	6645	6805	13'	6805	6645
19	6650	6810	14'	6810	6650
20	6655	6815	15'	6815	6655
21	6660	6820	16'	6820	6660
22	6665	6825	17'	6825	6665
23	6670	6830	18'	6830	6670
24	6675	6835	19'	6835	6675
25	6680	6840	20'	6840	6680
26	6685	6845	21'	6845	6685
27	6690	6850	22'	6850	6690
28	6695	6855	23'	6855	6695
29	6700	6860	24'	6860	6700
30	6705	6865	24'	6865	6705
31	6710	6870	24'	6870	6710

U6GHz (For Split Type)
CH Separation 5 MHz
Bandwidth 5 MHz (for 28MB System)
Shift Freq. 160 MHz

Low Band			High Band		
CH	TX	RX	CH	TX	RX
1	6545	6705	1'	6705	6545
2	6550	6710	2'	6710	6550
3	6555	6715	3'	6715	6555
4	6560	6720	4'	6720	6560
5	6565	6725	4'	6725	6565
6	6585	6745	1'	6745	6585
7	6590	6750	2'	6750	6590
8	6595	6755	3'	6755	6595
9	6600	6760	4'	6760	6600
10	6605	6765	5'	6765	6605
11	6610	6770	6'	6770	6610
12	6615	6775	7'	6775	6615
13	6620	6780	8'	6780	6620
14	6625	6785	9'	6785	6625
15	6630	6790	10'	6790	6630
16	6635	6795	11'	6795	6635
17	6640	6800	12'	6800	6640
18	6645	6805	13'	6805	6645
19	6650	6810	14'	6810	6650
20	6655	6815	15'	6815	6655
21	6660	6820	16'	6820	6660
22	6665	6825	17'	6825	6665
23	6670	6830	18'	6830	6670
24	6675	6835	19'	6835	6675
25	6680	6840	20'	6840	6680
26	6685	6845	21'	6845	6685
27	6690	6850	22'	6850	6690
28	6695	6855	23'	6855	6695
29	6700	6860	24'	6860	6700
30	6705	6865	24'	6865	6705

SYSTEM DESCRIPTION

ROI-S06300

U6GHz (For All Indoor w/o FAN Type)
CH Separation 10 MHz
Bandwidth 10 MHz (for 50 MB System)
Shift Freq. 160 MHz

Low Band			High Band			SUB BAND
CH	TX	RX	CH	TX	RX	
1	6585	6745	1'	6745	6585	A
2	6595	6755	2'	6755	6595	
3	6605	6765	3'	6765	6605	B
4	6615	6775	4'	6775	6615	
5	6625	6785	5'	6785	6625	C
6	6635	6795	6'	6795	6635	
7	6645	6805	7'	6805	6645	D
8	6655	6815	8'	6815	6655	
9	6665	6825	9'	6825	6665	E
10	6675	6835	10'	6835	6675	
11	6685	6845	11'	6845	6685	F
12	6695	6855	12'	6855	6695	
13	6705	6865	13'	6865	6705	G

U6GHz (For All Indoor e/w FAN Type)
CH Separation 10 MHz
Bandwidth 10 MHz (for 50 MB System)
Shift Freq. 160 MHz

Low Band			High Band		
CH	TX	RX	CH	TX	RX
1	6545	6705	1'	6705	6545
2	6555	6715	2'	6715	6555
3	6565	6725	3'	6725	6565
4	6585	6745	1'	6745	6585
5	6595	6755	2'	6755	6595
6	6605	6765	3'	6765	6605
7	6615	6775	4'	6775	6615
8	6625	6785	5'	6785	6625
9	6635	6795	6'	6795	6635
10	6645	6805	7'	6805	6645
11	6655	6815	8'	6815	6655
12	6665	6825	9'	6825	6665
13	6675	6835	10'	6835	6675
14	6685	6845	11'	6845	6685
15	6695	6855	12'	6855	6695
16	6705	6865	13'	6865	6705

U6GHz (For Split Type)
CH Separation 10 MHz
Bandwidth 10 MHz (for 50 MB System)
Shift Freq. 160 MHz

Low Band			High Band		
CH	TX	RX	CH	TX	RX
1	6545	6705	1'	6705	6545
2	6555	6715	2'	6715	6555
3	6565	6725	3'	6725	6565
4	6585	6745	1'	6745	6585
5	6595	6755	2'	6755	6595
6	6605	6765	3'	6765	6605
7	6615	6775	4'	6775	6615
8	6625	6785	5'	6785	6625
9	6635	6795	6'	6795	6635
10	6645	6805	7'	6805	6645
11	6655	6815	8'	6815	6655
12	6665	6825	9'	6825	6665
13	6675	6835	10'	6835	6675
14	6685	6845	11'	6845	6685
15	6695	6855	12'	6855	6695
16	6705	6865	13'	6865	6705

SYSTEM DESCRIPTION

ROI-S06300

10.5 GHz

Bandwidth 3.75 MHz for 15 MB System

Shift Freq. 65 MHz

Low Band			High Band			SUB BAND
CH	TX	RX	CH	TX	RX	
1	10553.125	10618.125	1 '	10618.125	10553.125	A
2	10558.125	10623.125	2 '	10623.125	10558.125	
3	10563.125	10628.125	3 '	10628.125	10563.125	B
4	10568.125	10633.125	4 '	10633.125	10568.125	
5	10573.125	10638.125	5 '	10638.125	10573.125	C
6	10578.125	10643.125	6 '	10643.125	10578.125	
7	10583.125	10648.125	7 '	10648.125	10583.125	D
8	10588.125	10653.125	8 '	10653.125	10588.125	
9	10593.125	10658.125	9 '	10658.125	10593.125	E
10	10598.125	10663.125	10 '	10663.125	10598.125	
11	10603.125	10668.125	11 '	10668.125	10603.125	F*

*Note: * Sub-Band "F" is available to both CH10 and CH11*

10.5 GHz

Bandwidth 5 MHz for 28 MB System

Shift Freq. 65 MHz

Low Band			High Band			SUB BAND
CH	TX	RX	CH	TX	RX	
1	10552.5	10617.5	1 '	10617.5	10552.5	A
2	10557.5	10622.5	2 '	10622.5	10557.5	
3	10562.5	10627.5	3 '	10627.5	10562.5	B
4	10567.5	10632.5	4 '	10632.5	10567.5	
5	10572.5	10637.5	5 '	10637.5	10572.5	C
6	10577.5	10642.5	6 '	10642.5	10577.5	
7	10582.5	10647.5	7 '	10647.5	10582.5	D
8	10587.5	10652.5	8 '	10652.5	10587.5	
9	10592.5	10657.5	9 '	10657.5	10592.5	E
10	10597.5	10662.5	10 '	10662.5	10597.5	
11	10602.5	10667.5	11 '	10667.5	10602.5	F*

*Note: * Sub-Band "F" is available to both CH10 and CH11.*

11 GHz (10700 - 11700 MHz) (For SRSP-310.7)

CH Separation 3.75 MHz

Bandwidth 3.75 MHz

Shift Freq. 490 MHz

Low Band			High Band			SUB BAND
CH	TX	RX	CH	TX	RX	
1	11116.875	11606.875	1'	11606.875	11116.875	D
2	11120.625	11610.625	2'	11610.625	11120.625	
3	11124.375	11614.375	3'	11614.375	11124.375	
4	11128.125	11618.125	4'	11618.125	11128.125	
5	11131.875	11621.875	5'	11621.875	11131.875	
6	11135.625	11625.625	6'	11625.625	11135.625	
7	11139.375	11629.375	7'	11629.375	11139.375	
8	11143.125	11633.125	8'	11633.125	11143.125	
9	11146.875	11636.875	9'	11636.875	11146.875	
10	11150.625	11640.625	10'	11640.625	11150.625	
11	11154.375	11644.375	11'	11644.375	11154.375	
12	11158.125	11648.125	12'	11648.125	11158.125	
13	11161.875	11651.875	13'	11651.875	11161.875	
14	11165.625	11655.625	14'	11655.625	11165.625	
15	11169.375	11659.375	15'	11659.375	11169.375	
16	11173.125	11663.125	16'	11663.125	11173.125	
17	11176.875	11666.875	17'	11666.875	11176.875	
18	11180.625	11670.625	18'	11670.625	11180.625	
19	11184.375	11674.375	19'	11674.375	11184.375	
20	11188.125	11678.125	20'	11678.125	11188.125	
21	11191.875	11681.875	21'	11681.875	11191.875	

SYSTEM DESCRIPTION

ROI-S06300

11 GHz (10700 - 11700 MHz) (For SRSP-310.7)

Bandwidth 5 MHz

Shift Freq. 490 MHz

Low Band			High Band			SUB BAND
CH	TX	RX	CH	TX	RX	
1	11117.5	11607.5	1'	11607.5	11117.5	D
2	11122.5	11612.5	2'	11612.5	11122.5	
3	11127.5	11617.5	3'	11617.5	11127.5	
4	11132.5	11622.5	4'	11622.5	11132.5	
5	11137.5	11627.5	5'	11627.5	11137.5	
6	11142.5	11632.5	6'	11632.5	11142.5	
7	11147.5	11637.5	7'	11637.5	11147.5	
8	11152.5	11642.5	8'	11642.5	11152.5	
9	11157.5	11647.5	9'	11647.5	11157.5	
10	11162.5	11652.5	10'	11652.5	11162.5	
11	11167.5	11657.5	11'	11657.5	11167.5	
12	11172.5	11662.5	12'	11662.5	11172.5	
13	11177.5	11667.5		11667.5	11177.5	
14	11182.5	11672.5	4'	11672.5	11182.5	
15	11187.5	11677.5	5'	11677.5	11187.5	
16	11192.5	11682.5	6'	11682.5	11192.5	

11 GHz (All Indoor w/o FAN Type)
Bandwidth 5 MHz for 28 MB System
Shift Freq. 490 MHz

Low Band			High Band			SUB BAND
CH	TX	RX	CH	TX	RX	
1	11132.5	11622.5	1'	11622.5	11132.5	D
2	11137.5	11627.5	2'	11627.5	11137.5	
3	11142.5	11632.5	3'	11632.5	11142.5	
4	11147.5	11637.5	4'	11637.5	11147.5	
5	11152.5	11642.5	5'	11642.5	11152.5	
6	11157.5	11647.5	6'	11647.5	11157.5	
7	11162.5	11652.5	7'	11652.5	11162.5	
8	11167.5	11657.5	8'	11657.5	11167.5	
9	11172.5	11662.5	9'	11662.5	11172.5	
10	11177.5	11667.5	10'	11667.5	11177.5	

11 GHz (All Indoor w/o FAN Type)
Bandwidth 3.75 MHz for 15 MB System
Shift Freq. 490 MHz

Low Band			High Band			SUB BAND
CH	TX	RX	CH	TX	RX	
1	11133.125	11623.125	1'	11623.125	11133.125	D
2	11138.125	11628.125	2'	11628.125	11138.125	
3	11143.125	11633.125	3'	11633.125	11143.125	
4	11148.125	11638.125	4'	11638.125	11148.125	
5	11153.125	11643.125	5'	11643.125	11153.125	
6	11158.125	11648.125	6'	11648.125	11158.125	
7	11163.125	11653.125	7'	11653.125	11163.125	
8	11168.125	11658.125	8'	11658.125	11168.125	
9	11173.125	11663.125	9'	11663.125	11173.125	
10	11178.125	11668.125	10'	11668.125	11178.125	

11 GHz (All Indoor w/o FAN Type)
Bandwidth 10 MHz for 50 MB System
Shift Freq. 490 MHz

Low Band			High Band			SUB BAND
CH	TX	RX	CH	TX	RX	
1	10735	11225	1 '	11225	10735	A
2	10745	11235	2 '	11235	10745	
3	10755	11245	3 '	11245	10755	
4	10765	11255	4 '	11255	10765	
5	10775	11265	5 '	11265	10775	
6	10785	11275	6 '	11275	10785	
7	10795	11285	7 '	11285	10795	
8	10805	11295	8 '	11295	10805	
9	10815	11305	9 '	11305	10815	
10	10825	11315	10 '	11315	10825	

11 GHz (All Indoor w/o FAN Type)
CH Separation 10 MHz
Bandwidth 10 MHz for 50 MB System
Shift Freq. 490 MHz

Low Band			High Band			SUB BAND
CH	TX	RX	CH	TX	RX	
1	10835	11325	1 '	11325	10835	B
2	10845	11335	2 '	11335	10845	
3	10855	11345	3 '	11345	10855	
4	10865	11355	4 '	11355	10865	
5	10875	11365	5 '	11365	10875	
6	10885	11375	6 '	11375	10885	
7	10895	11385	7 '	11385	10895	
8	10905	11395	8 '	11395	10905	
9	10915	11405	9 '	11405	10915	
10	10925	11415	10 '	11415	10925	
11	10935	11425	11 '	11425	10935	
12	10945	11435	12 '	11435	10945	

11 GHz (All Indoor w/o FAN Type)
Bandwidth 10 MHz for 50 MB System
Shift Freq. 490 MHz

Low Band			High Band			SUB BAND
CH	TX	RX	CH	TX	RX	
1	10955	11445	1'	11445	10955	C
2	10965	11455	2'	11455	10965	
3	10975	11465	3'	11465	10975	
4	10985	11475	4'	11475	10985	
5	10995	11485	5'	11485	10995	
6	11005	11495	6'	11495	11005	
7	11015	11505	7'	11505	11015	
8	11025	11515	8'	11515	11025	
9	11035	11525	9'	11525	11035	
10	11045	11535	10'	11535	11045	
11	11055	11545	11'	11545	11055	
12	11065	11555	12'	11555	11065	

11 GHz (All Indoor w/o FAN Type)
Bandwidth 10 MHz for 50 MB System
Shift Freq. 490 MHz

Low Band			High Band			SUB BAND
CH	TX	RX	CH	TX	RX	
1	11075	11565	1'	11565	11075	D
2	11085	11575	2'	11575	11085	
3	11095	11585	3'	11585	11095	
4	11105	11595	4'	11595	11105	
5	11115	11605	5'	11605	11115	
6	11125	11615	6'	11615	11125	
7	11135	11625	7'	11625	11135	
8	11145	11635	8'	11635	11145	
9	11155	11645	9'	11645	11155	
10	11165	11655	10'	11655	11165	
11	11175	11665	11'	11665	11175	

SYSTEM DESCRIPTION

ROI-S06300

11 GHz (All Indoor e/w FAN Type)
Bandwidth 10 MHz
Shift Freq. 490 MHz (500 MHz)

Low Band			High Band		
CH	TX	RX	CH	TX	RX
1	10705	11205	1'	11205	10705
2	10715	11215	2'	11215	10715
3	10725	-	3'	-	10725
4	10735	11225	1'	11225	10735
5	10745	11235	2'	11235	10745
6	10755	11245	3'	11245	10755
7	10765	11255	4'	11255	10765
8	10775	11265	5'	11265	10775
9	10785	11275	6'	11275	10785
10	10795	11285	7'	11285	10795
11	10805	11295	8'	11295	10805
12	10815	11305	9'	11305	10815
13	10825	11315	10'	11315	10825
14	10835	11325	11'	11325	10835
15	10845	11335	12'	11335	10845
16	10855	11345	13'	11345	10855
17	10865	11355	14'	11355	10865
18	10875	11365	15'	11365	10875
19	10885	11375	16'	11375	10885
20	10895	11385	17'	11385	10895
21	10905	11395	18'	11395	10905
22	10915	11405	19'	11405	10915
23	10925	11415	20'	11415	10925
24	10935	11425	21'	11425	10935
25	10945	11435	22'	11435	10945
26	10955	11445	23'	11445	10955
27	10965	11455	24'	11455	10965
28	10975	11465	25'	11465	10975
29	10985	11475	26'	11475	10985
30	10995	11485	27'	11485	10995
31	11005	11495	28'	11495	11005
32	11015	11505	29'	11505	11015
33	11025	11515	30'	11515	11025
34	11035	11525	31'	11525	11035
35	11045	11535	32'	11535	11045
36	11055	11545	33'	11545	11055
37	11065	11555	34'	11555	11065
38	11075	11565	35'	11565	11075
39	11085	11575	36'	11575	11085
40	11095	11585	37'	11585	11095
41	11105	11595	38'	11595	11105
42	11115	11605	39'	11605	11115

*
*

11 GHz (All Indoor e/w FAN Type)
Bandwidth 10 MHz
Shift Freq. 490 MHz (500 MHz)

Low Band			High Band		
CH	TX	RX	CH	TX	RX
43	11125	11615	40'	11615	11125
44	11135	11625	40'	11625	11135
45	11145	11635	40'	11635	11145
46	11155	11645	40'	11645	11155
47	11165	11655	40'	11655	11165
48	11175	11665	40'	11665	11175
49	11185	11685	40'	11685	11185
50	11195	11695	40'	11695	11195

*
*

Note: Shift Frequency is 500 MHz.

SYSTEM DESCRIPTION

ROI-S06300

24 GHz (For Split Type)

CH Separation 10 MHz

Bandwidth 10 MHz

Shift Freq. 800 MHz

Low Band		High Band	
TX	RX	TX	RX
24250 - 25250	25250 - 24250	25250 - 24250	24250 - 25250

2.4 Alarm and Control

The alarm and control system is shown in Fig. 2-7. The functions of the alarm and control circuit are as follows:

- Alarm indication and external output
- Performance monitoring/metering data reporting
- Automatic transmitter power control
- Loopback control
- Network Management (Optional)

2.4.1 Alarm Indication and Reporting

Alarm indication and reporting functions are provided with the CTRL UNIT. Summary alarm indicators using LED's are provided on the front panel of the CTRL UNIT for the TRP and MDP separately. The operating status of the TRP and MDP are monitored by the alarm detectors that communicate with the CTRL module. External parallel alarm outputs are provided on the front panel of the CTRL UNIT and apply through relay contact Mode-C (see Table 2-4). The NMS access terminals provided on the front panel of the CTRL UNIT are used for the NLite L system management (optional).

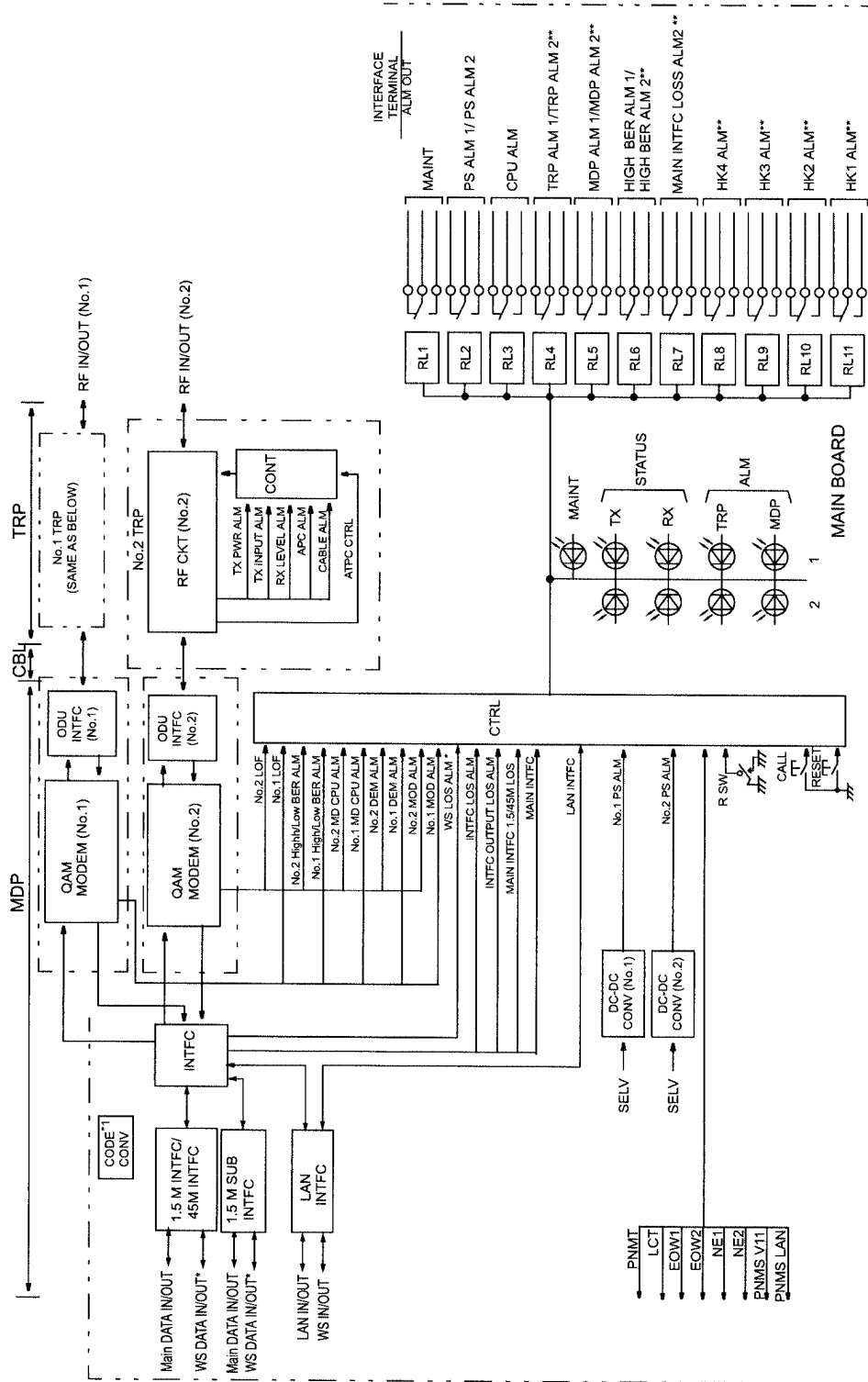

8 x DS1 / 16 x DS1 / 28 x DS1 / 1 x DS3 SYSTEM

Notes: 1. * Optional.
 2. ** These alarm items can be set by the LCT.

Fig. 2-7 Alarm and Control Functional Block Diagram

Table 2-4 Alarm Indication and Reporting

Equipment	Unit	Alarm Initiated	Alarm Initiating Module	Alarm Condition	LED Indication on MDP	Remote Alarm Reporting
MDP	MD UNIT (No.1/No.2)	MOD ALM	MODEM	Alarm detected of TX side of MD UNIT	No.1 MDP ALM or No.2 MDP ALM	MDP ALM 1 or MDP ALM 2
		DEM ALM	MODEM	Alarm is detected at RX side of the MD UNIT	No.1 MDP ALM or No.2 MDP ALM	MDP ALM 1 or MDP ALM 2
		MD CPU ALM	MODEM	Communication between modules failure	No.1 MDP ALM or No.2 MDP ALM	MDP ALM 1 or DEM ALM 2
		LOF	MODEM	Frame synchronization is lost	No.1 MDP ALM or No.2 MDP ALM	MDP ALM 1 or MDP ALM 2
		HIGH BER ALM	MODEM	BER is worse than preset value (3×10^{-4} , 3×10^{-5} , 3×10^{-6})	No.1 MDP ALM or No.2 MDP ALM	DEM ALM 1 or DEM ALM 2
		LOW BER ALM	MODEM	BER is worse than preset value (3×10^{-6} , 7×10^{-7} , 3×10^{-8})	No.1 MDP ALM or No.2 MDP ALM	HIGH BER ALM 1 or HIGH BER ALM 2
		MODEM	MODEM	MODEM module failure	No.1 MDP ALM or No.2 MDP ALM	LOW BER ALM 1 or LOW BER ALM 2
		POWER SUPPLY *1	DC-DC CONV	DC-DC CONV module failure	No.1 MDP ALM or No.2 MDP ALM	MDP ALM 1 or MDP ALM 2
		INPUT LOSS	Main Board	Main channel (CH1-CH16*) input signal is lost	No.1 MDP ALM and No.2 MDP ALM	MDP ALM 1 or PS ALM 2
		OUTPUT LOSS	Main Board	Main channel (CH1-CH16*) output signal is lost	No.1 MDP ALM and No.2 MDP ALM	MDP ALM 1 and MDP ALM 2
		AIS GENERATED	Main Board	AIS signal is sending	No.1 MDP ALM and No.2 MDP ALM	AIS Generated
		AIS RECEIVED	Main Board	AIS signal is detected	No.1 MDP ALM and No.2 MDP ALM	AIS Received
		CHANNEL USAGE ERROR *3	Main Board	Reports that signal is applied to the CH interface which is set to Not Used	No.1 MDP ALM and No.2 MDP ALM	Channel Usage Error
TRP (No.1/No.2)	—	Port1/Port2 LINK DOWN	LAN INTFC	LAN PORT is LINK DOWN	No.1 MDP ALM and No.2 MDP ALM	LAN INTFC ALM LINK-1/2 ALM
		TX PWR ALM	RF CKT	Transmit RF power increases/decreases approx. 3 dB from normal	No.1 TRP ALM or No.2 TRP ALM	TRP ALM 1 or TRP ALM 2
		TX INPUT ALM	RF CKT	TX IF input signal from MDP is lost	No.1 TRP ALM or No.2 TRP ALM	TX PWR ALM 1 or 2
		RX LEVEL ALM	RF CKT	Receiver input level decreases below squelch level	No.1 TRP ALM or No.2 TRP ALM	TRP ALM 1 or TRP ALM 2
		APC ALM	SYNTH/RF CKT	Local oscillator is unlocked	No.1 TRP ALM or No.2 TRP ALM	RX LEVEL ALM 1 or 2
		CABLE ALM	IF Cable	Communication between MDP and TRP is lost	No.1 TRP ALM or No.2 TRP ALM	TRP ALM 1 or TRP ALM 2
MDP/TRP	—	MAINT	—	The equipment is in maintenance mode. In this mode, the following control operations can be performed. • ATPC manual control • Loopback • RF SW manual control • TX/RX SW manual control • CW	No.1 TRP/MDP ALM or No.2 TRP/MDP ALM *2	MAINT

Note: *1 When No.1 and No.2 MDP UNIT are mounted.
*2 When the IF cable is open, TRP alarm indicator turns on flashing.
*3 Selectable

2.4.2 Performance Monitoring/Metering Data Reporting

To monitor the transmission quality, the equipment is provided with the performance monitoring and the metering functions. The CTRL module polls the different modules and gathers PM/Metering information. A “invalid” displayed in the PM results screen indicates that the value is illegal. A “MAINT” is displayed if the PM results are obtained while the equipment is in maintenance mode. When the equipment clock setting is changed or the power is turned on/off, the PM value is judged to be invalid. The monitoring items are as follows:

Performance Monitor

- Out of Frame Second (OFS)
- Background Block Error (BBE)
- Errored Seconds (ES)
- Severely Errored Seconds (SES)
- Unavailable Second (UAS)

Metering

- TX POWER
- RX LEVEL
- TRP PS MON
- BER (Bit Error Rate)

2.4.3 Automatic Transmitter Power Control

The automatic transmit power control (ATPC) function automatically varies the TX output power according to path conditions. In the SHF and EHF band, fading exerts heavy influences on propagation, causing the receive signal level at the opposite station to vary. The ATPC function operates by controlling the transmit output power of the opposite station according to the variation of the received signal level at the local station. ATPC provides the following advantages:

- Improvement in up fading characteristics
- Improvement in residual BER characteristics
- Reduction of interference to intra system
- Reduction of interference to inter system

A functional block diagram of the ATPC operation is shown in Fig. 2-6. ATPC improves the BER characteristics under adverse changes in climatic conditions and reduces the possibility of interference. To implement ATPC, the received signal level (RX LEV) is detected by the receiver (RX) and passed on to the CPU on the CTRL circuit of the MODEM module. The CPU then determines whether the transmit output power needs to be controlled. This is based on the transmit output power, the minimum and maximum values of the output control range (ATPC range), ATPC is relevant for the receiving threshold (RX Threshold) level that were previously specified value using the LCT or PNMT.

A control signal (POWER CTRL), whose function is to maintain the RX signal by lowering or raising the TX output power of the opposite station, is generated by the MODEM module through the CPU circuit. This control signal is based on the result of comparison between the current receiver input level and the preset receiving threshold level. This control signal is sent to the opposite station to control its transmit output power.

At the opposite station, this control signal is detected by the MODEM module. It the MODEM module, in accordance with this control signal, produces a control that will either raise, lower or maintain the current TX output power.

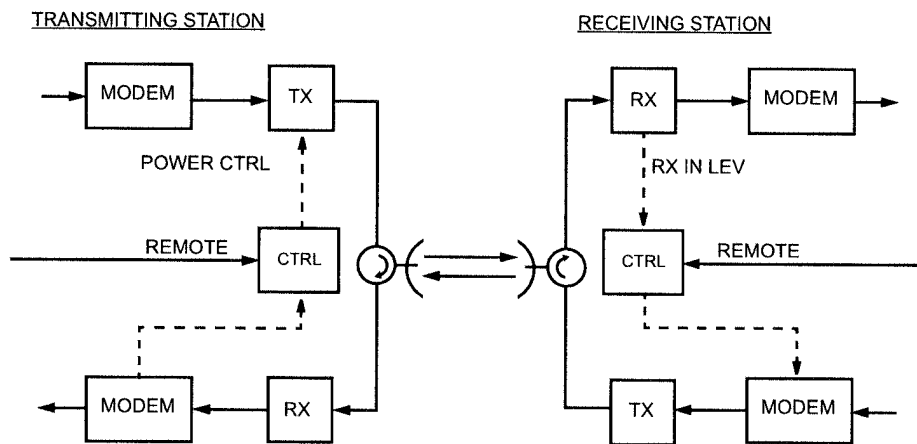
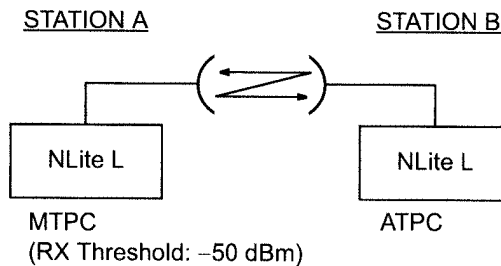

Fig. 2-8 ATPC, Functional Block Diagram

The ATPC Control System of the NLite L transmits the information on the received signal level to the opposite station and controls the transmission level of its local station in accordance with the receiving level of the opposite station. Transmission level control can be used not only for setting the same operation (ATPC-ATPC) between local station and opposite station but also for operation in combination of stations with different operation (MTPC-ATPC, ATPC-MTPC) between own station and opposite station. The station set in MTPC mode is not controlled by the information from opposite station but is fixed in its transmitting output level.

Even if the station is set in the MTPC mode, the opposite station is likely to be set in the ATPC mode. Therefore, setting the RX Threshold (Receiving threshold level) is required for controlling the transmission level of the opposite station. Between the stations that are respectively set in the MTPC mode, however, the setting is disabled.

The following is an example of operation between stations set in MTPC-ATPC mode.



The transmitting level of station B is controlled so that the receiving level of station A in the above figure reaches the RX Threshold set level (-50 dBm) set in station A. This method is used in station A for reducing the level of interference to other route. As station A is set in the MTPC mode, the transmitting level is kept unchanged.

Then an example of using MTPC-ATPC is shown below. As shown in the figure, in the master station communicating with many substations, waves gather from substations possibly causing interferences. Therefore, substations must be set in the ATPC mode to minimize the diffraction (interference) to other routes while reducing the receiving levels from individual substations to the minimum. In substations, there is little possibility of occurring interferences; therefore, the master station is set in the MTPC mode to permit transmission at a constant level.

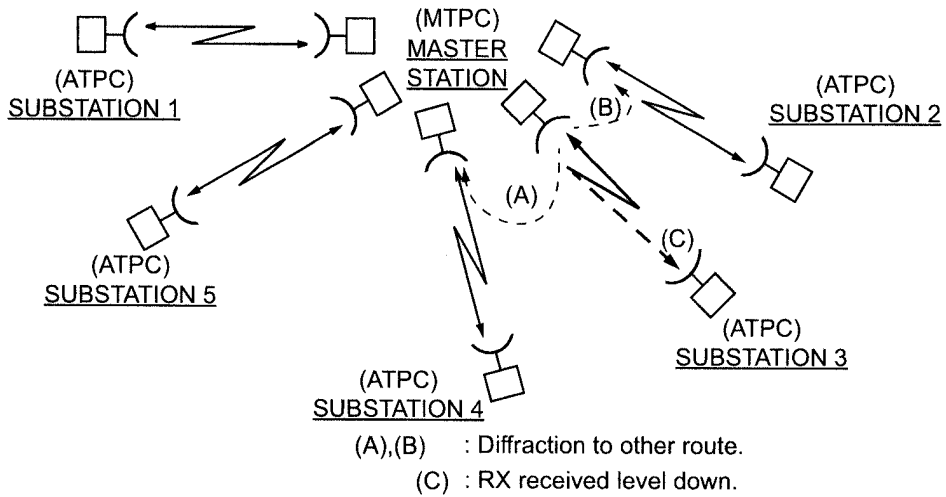

A constant transmit output power in both MTPC and ATPC is maintained using the ALC function which is provided in the RF CKT module. The ALC circuit detect the transmit output power using a diode to obtain a DC voltage proportional to the transmit power. The gain of the RF amplifier is controlled inversely with this detected DC voltage to maintain the transmit output power within the specified limits.

2.4.4 Loopback Control

The loopback function is provided for checking the system quality during maintenance and/or to quickly isolate a fault location. The control is performed by the LCT, the PNMT or the PNMS.

The following types of loopback are provided:

- DS1 near-end loopback (DS1 LB1) at the CTRL module ((a) in Fig. 2-9).
- Main DS1 far-end loopback (DS1 LB2) at the CTRL module ((b) in Fig. 2-9).
- IF loopback (IF-LB) at the MODEM module ((c) in Fig. 2-9).

Notes: 1. While the IF loopback is in execution, monitoring of the opposite and the subsequent stations are disabled on the PNMS and PNMT.

2. Loopback control will interrupt the radio link connection.

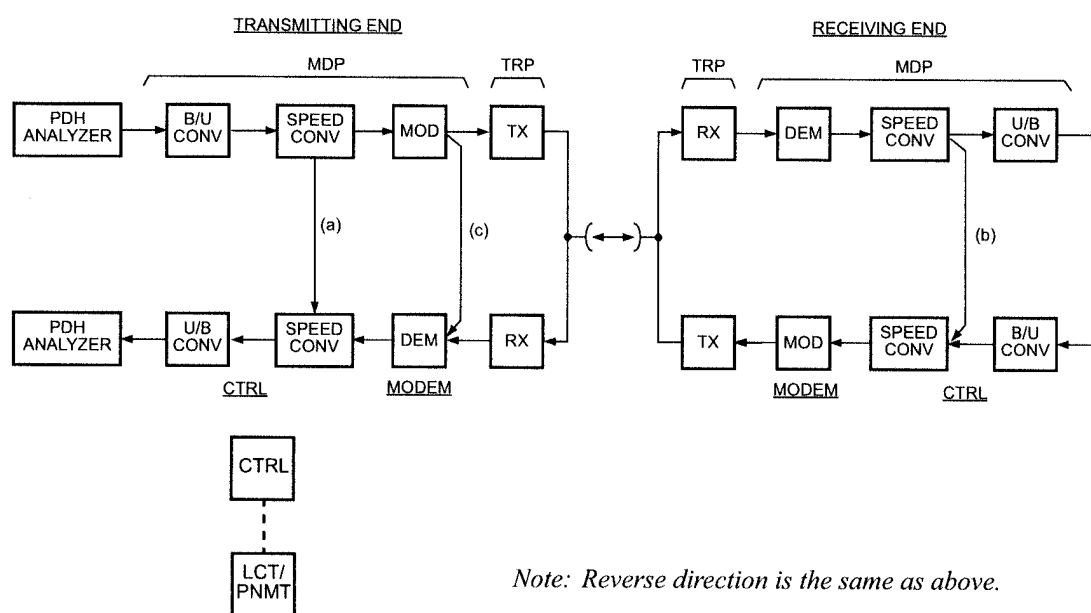

Note: Reverse direction is the same as above.

Fig. 2-9 Loopback Location

2.4.5 Link Loss Forwarding Control (LAN)

Link Loss Forwarding (LLF) control provides two kinds of functions for the 10/100BASE-T interface. One is to automatically stop the output from the LAN port to alert the equipment connected with the LAN port when the system has been disconnected by the fault in the radio section. The other is to transmit the information for cutting the link interconnected with the LAN port in the opposite station when the link between the LAN port and equipment is faulty. Either mode can be selected by setting "Provisioning" on LCT to "Enable" or "Disable".

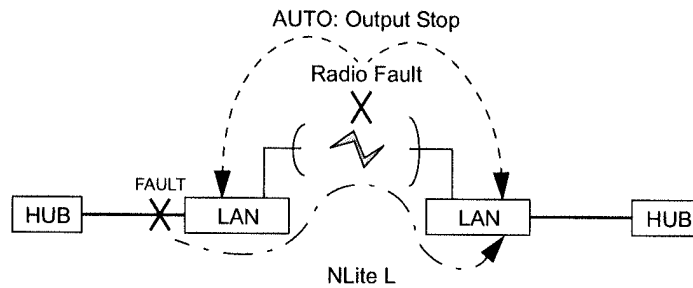

2.4.6 Network Management (Optional)

The Network Management System (NMS) configuration is shown in Fig. 2-10. The pasolink network management system (PNMS) is connected to the PNMS V.11/LAN connector of the MDP located at the designated maintenance centre while the pasolink network management terminal (PNMT) is connected to the PNMT connector on the MDP of remote stations. The PNMT/PNMS provides monitoring and control of the actual microwave link status and its associated NLite L equipment. Status information form and control signals to remote stations are transmitted using one of the SC channels.

Note: This SC channel is multiplexed on the main signal for subsequent transmission to the opposite station. If the IF loopback is executed the SC channels of the station under maintenance will also be looped back, thereby making it impossible to monitor or control the opposite and the subsequent stations

For detailed information, refer to the related PNMS or PNMT manual.

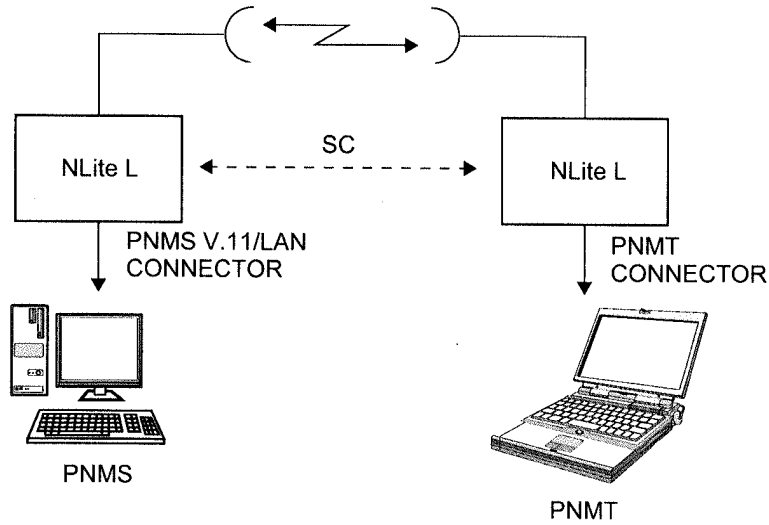

PNMS: Pasolink Network Management System
 PNMT: Pasolink Network Management Terminal

Fig. 2-10 Network Management System

2.5 Protection Switching

Protection switching is provided for the TX and RX sections in the Hot Standby (HS) system and is performed by automatic control and manual control.

The TX protection switching is performed by the RF switch or MUTE control on the TRP at the transmitting end of the Hot Standby system. The RX protection switching is performed by the Hitless Switch (HL SW)* on the SW UNIT of the MDP at the receiving end of the Hot Standby system.

Note: The hitless switching of Main DS1 or DS3 data is performed when the detected BER exceeds the internally preset value (3×10^{-6} to -8) in automatic switching mode. When switching is performed by manual control or by an alarm event, hit is occurred by switching.

The manual control should be performed in maintenance status. This is because automatic switching is implemented by hardware logic and manual switching is implemented by software logic. That is, automatic switching and manual switching are completely independent and different switching conditions. Then, note that when the operator reverts to automatic switching after performing manual switching, the channel will be re-selected by the automatic switch control.

When the Silent Failure occurs in the HS/HS or HS/SD system, reverse TX SW switching is performed by the switching request signal which is sent from the receiving side.

2.5.1 Switching Control

(a) TX Switching

The TX switching is performed by manual or automatic control.

In the automatic switching mode, No.1 can be given Priority or Non-priority. Under the priority mode, when switchover has been performed from No.1 to No.2 caused by No.1 alarm, reversal switchover is performed automatically from No.2 to No.1 when alarm condition of the No.1 is restored. Under the Non-priority mode, the switchover is performed alternately from No.1 to No.2 or vice versa according to the alarm status of a failure in the transmit section of the MDP, IF cable or TRP.

The TX switching condition is shown on the LCT and by the TX1 and TX2 STATUS indicators on the SW UNIT.

The manual switching mode that is initiated by the operator using the LCT.

TX switching, either initiated manually or automatically, may cause a short interruption of the data. Automatic and manual TX switching have the following operational characteristics:

- Switching Mode: 1. Manual switching
2. Automatic switching
- Switching Priority: 1. Non-priority (Non-revertive)
2. Priority No.1

Note: In non-priority mode, the channel currently selected remains even if the alarm in the previously selected channel is normalized.

(b) RX Switching

The RX switching is performed by the HL SW on the SW UNIT of the MDP in the Hot Standby system.

The RX switching is performed by manual or automatic control.

The manual control is executed by operator from the LCT in maintenance status. The automatic switching that is initiated by detection of a failure in the receive section of the MDP or TRP.

The switching priority and switching conditions for automatic and manual switching are identical to those of TX switching. The switching condition is shown on the LCT and by the RX1 and RX2 STATUS indicators on the SW UNIT.

2.5.2 TX Switchover in Silent Failure

In the Silent Failure condition (i.e. the RX alarm condition in both No.1 and No.2 simultaneously occurs at the receiving side without TX alarm in the transmitting side), the TX switching is performed once through a TX SW reverse switchover request signal which is applied from the receiving side.

The function can be applied not only HS/SD system but also HS/HS system.

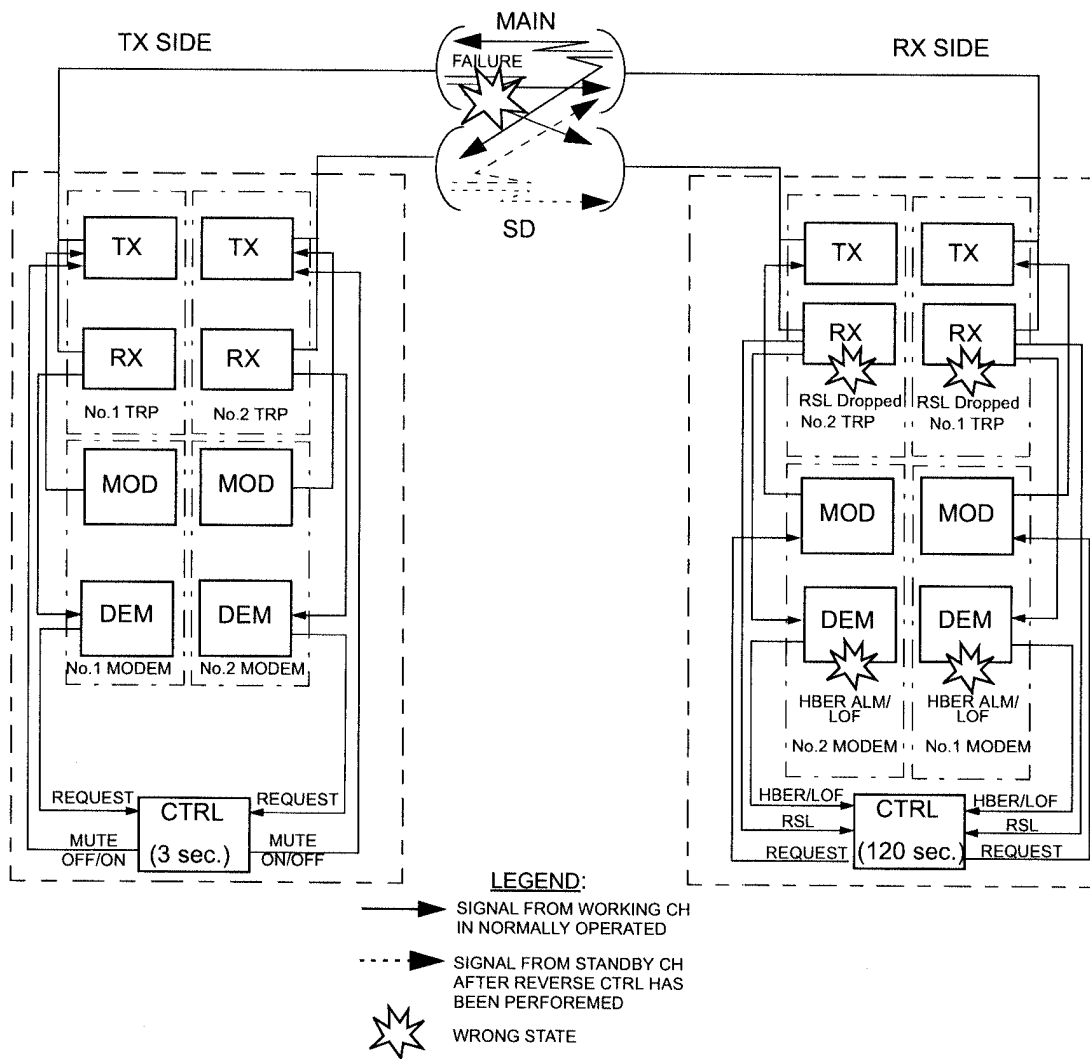

Fig. 2-11 TX SW Reverse Control in Silent Failure (HS/SD Configuration)

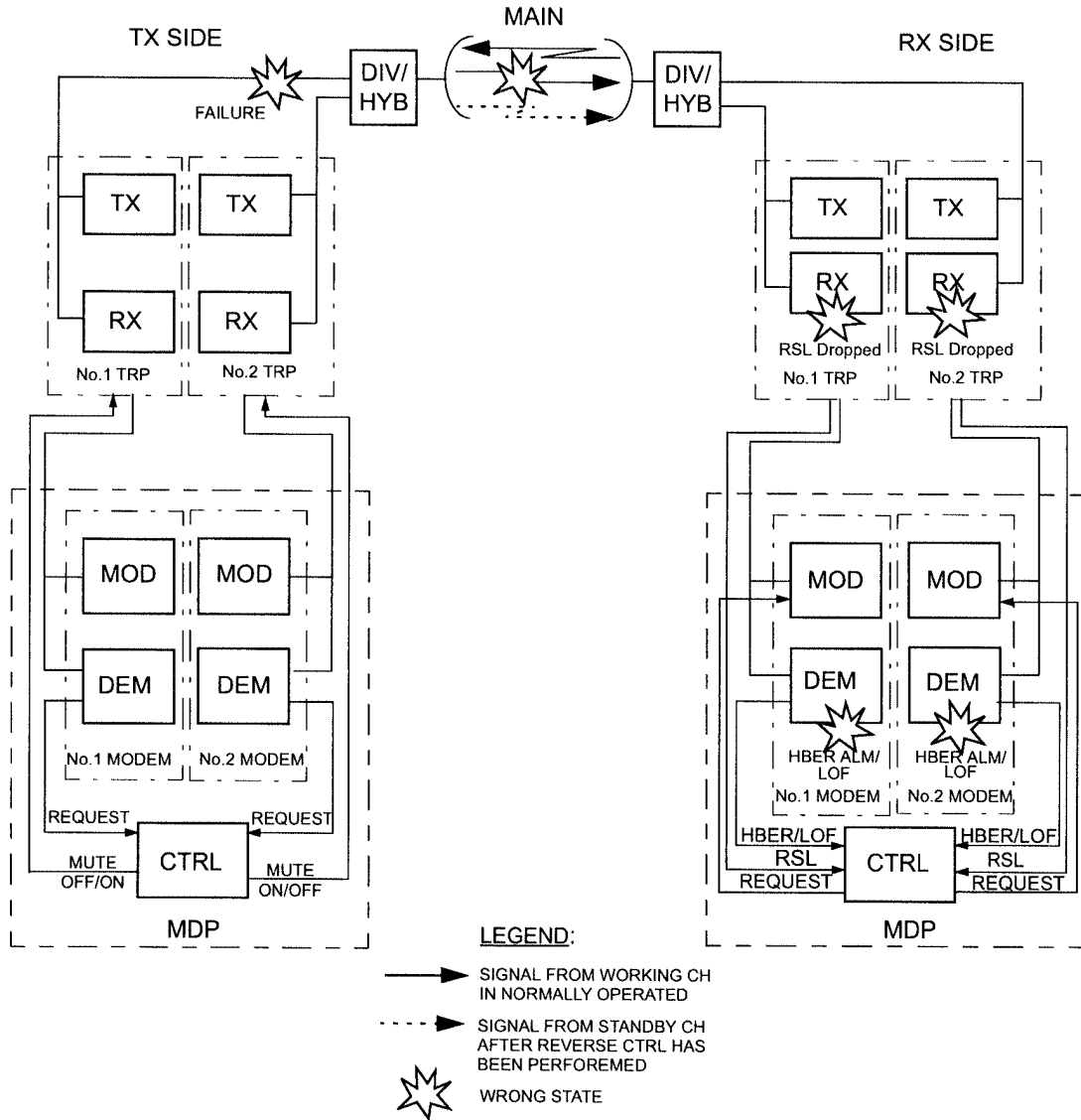

Fig. 2-12 TX SW Reverse Control in Silent Failure (HS/HS Configuration)

TX SW CTRL SYSTEM in 1+1 HS Configuration

HS System	TX SW	
	All Indoor Type	Sprit Type
HS/HS (1 antenna)	RF SW	Mute
HS/SD (2 antennas)	Mute	Mute

The TX SW Switchover Reverse Control is performed when the following condition is detected at the receiving side.

TX SW Reverse Control Activation Condition

Receiving Side	Transmitting Side
<p>When the following condition continues more than 120 sec., TX SW reverse switchover request signal is sent to the opposite station. <i>Note*3</i></p> <ul style="list-style-type: none"> • Received Signal Level is dropped below specified and/or • HIGH BER ALM is detected and/or <i>Note*1</i> • LOF (Lose Of Frame) is detected. 	<p>TX SW reverse switchover is carried out when the switchover request signal has been received for a 3 sec. or more. <i>Note*2</i></p>

*Note *1:* In the HBER ALM condition, AIS is generated in the receiving side.

*Note *2:* When the transmitting side is under the following condition, TX SW switchover reverse control is not activated, although the TX SW reverse switchover request signal is received.

1. When the NLite L system is restarting up,
2. Maintenance mode is "ON",
3. TX SW switching for No.1 takes priority,
4. When RF Frequency has not been decided in system configuration setting,
5. When equipment alarm is detected in both No.1 and No.2 channels, or
6. When equipment alarm is detected in either No.1 or No.2 channel, (ordinal protection switching is performed).

*Note *3:* When the receiving side is under the following condition, TX SW reverse switchover request signal is not sent to the transmitting side, although the RSL Dropp and/or HBER ALM and/or LOF is detected .

1. When the NLite L system is restarting up,
2. Maintenance mode is "ON",
3. TX SW switching for No.1 takes priority,
4. When RF Frequency has not been decided in system configuration setting, or
5. When equipment alarm is detected in both No.1 and No.2 channels.

2.6 CODE CONVERSION (Optional)

The code conversion of DS1 signals from AMI to B8ZS or vice versa can be performed through the CODE CONV module (for the 8DS1/16DS1 INTFC). The code conversion for the CH17 to CH28 in the 28DS1 system is included in the 1.5M SUB INTFC module and either AMI or B8ZS coded signal is selectable with software setting (for CH17 to CH28) or rotary switch (for CH27 and CH28) setting.

The CODE CONV module includes of two encoder/decoder circuits and equalizer circuit which compensates cable loss of 0 to 655 feet for the output signals.

The CODE CONV can be connected 1.5 M INTFC which is set the bipolar code to AMI or B8ZS at each LIU (4 CH) through interface cable as shown in Fig. 2-11 Code Conversion Connection 1/3 to 3/3. The bipolar code for 1.5M INTFC is set via LCT with a 4 group channels each.

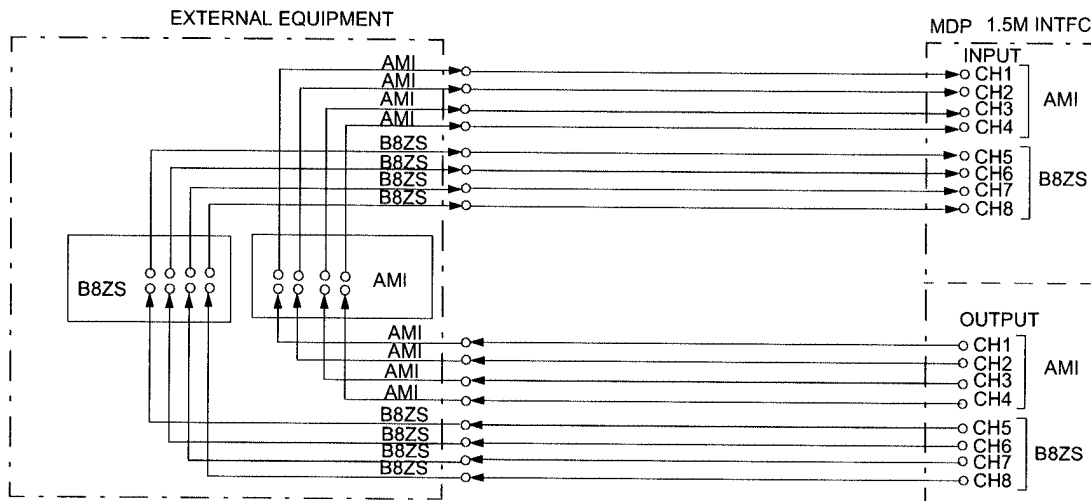

(a) Example when 4x B8ZS and 4x AMI are applied for external interface.

Fig. 2-13 Code Conversion Connection (1/4)

Set the rotary switch on the CODE CONV module to the position corresponding to the code type and cable length when the CODE CONV module is used.

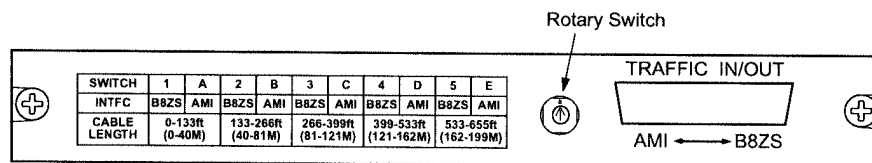

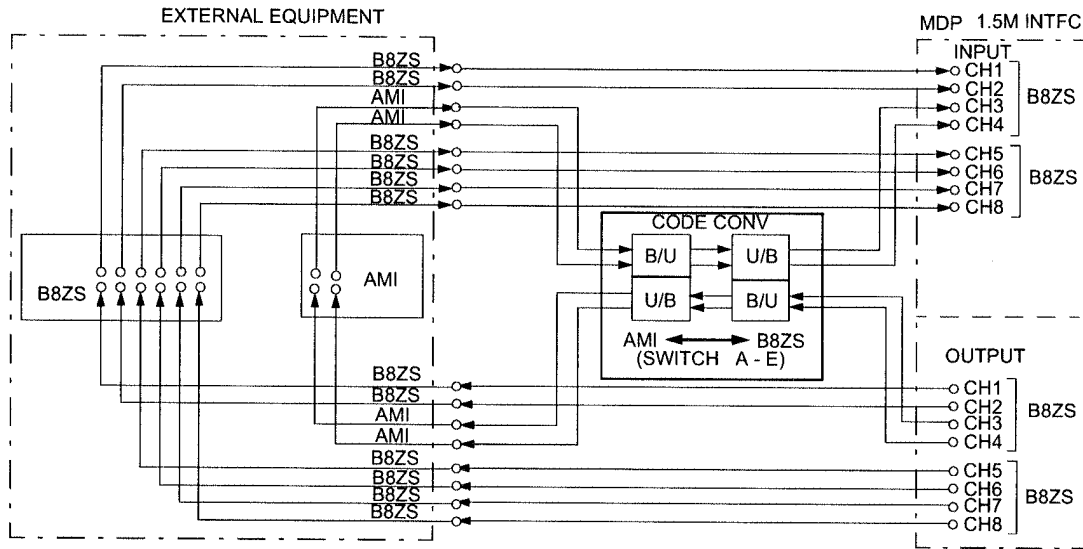

(b) Example when 6×B8ZS and 2×AMI are applied for external interface.

Fig. 2-13 Code Conversion Connection (2/4)

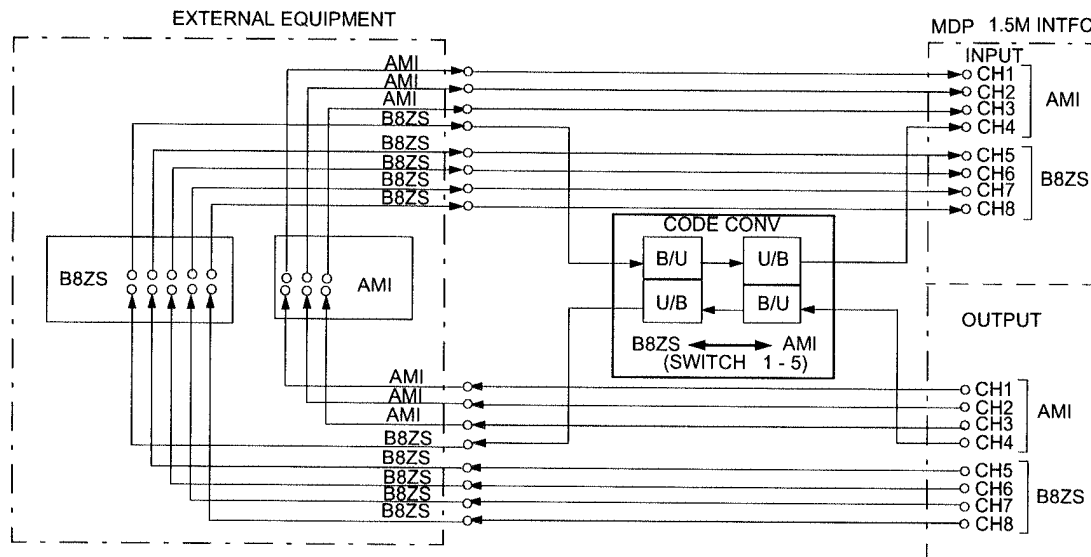

(c) Example when 5×B8ZS and 3×AMI are applied for external interface.

Fig. 2-13 Code Conversion Connection (3/4)

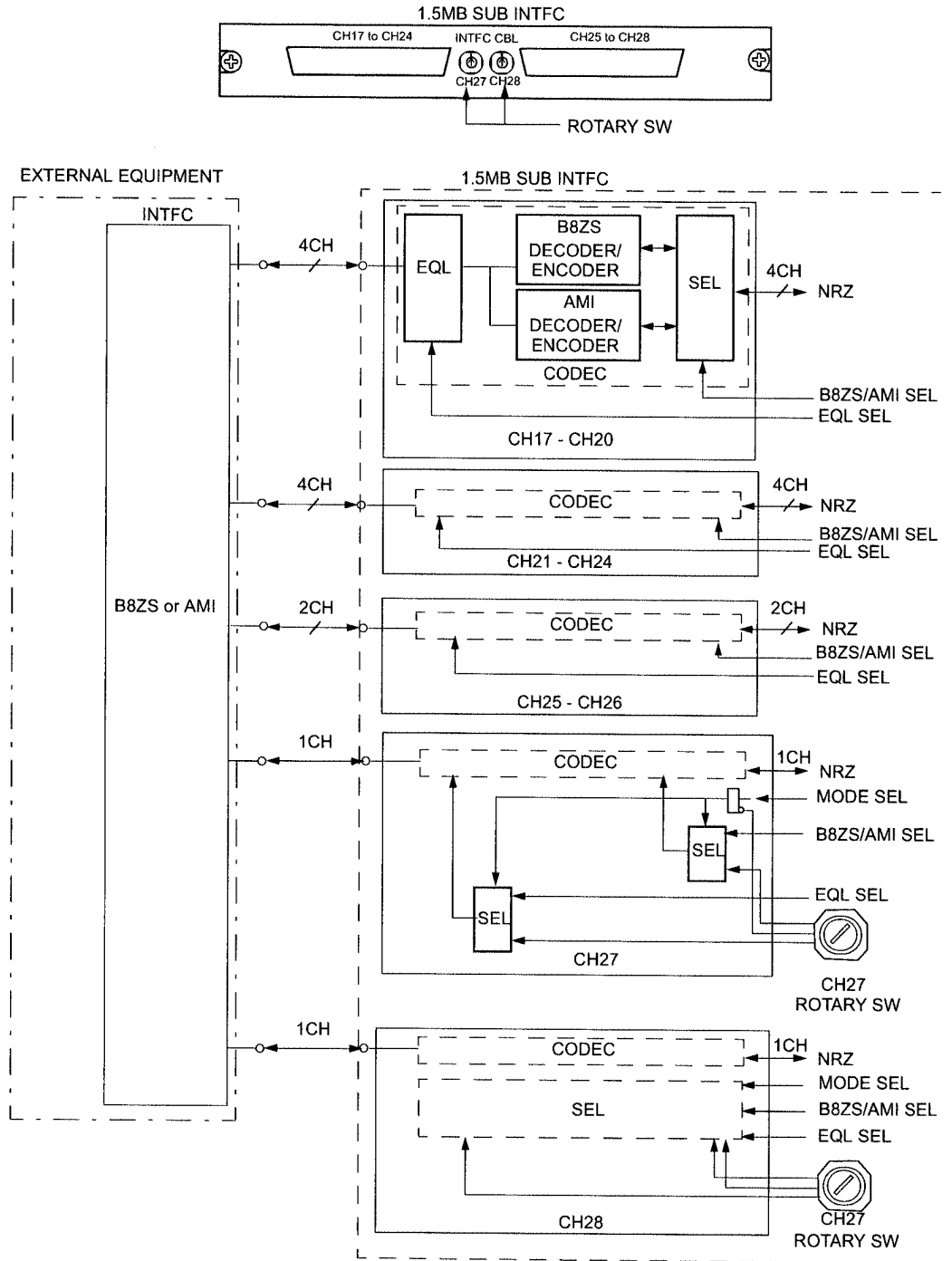

(d) An example when CH17 - CH38 are applied for external interface.

Fig. 2-13 Code Conversion Connection (4/4)

2.7 Power Supply

The power supply system block diagram is shown in Fig. 2-12. The DC-DC CONV module on the MDP produces regulated +5.3 and +3.6 V DC power from +48/-48 V DC input power (*1) for the component modules in the MDP. Also, this module produces a regulated -43 V DC power from the -48 V DC input power for the TRP.

The power to the TRP is supplied through the coaxial cable which is also used for the IF and other signals. The DC-DC CONV module of the TRP produces +7/+9/+10 and -15 V DC power for the component modules from the -43 V DC power supplied from the MDP.

The power supply from the SEL V input terminal on the TRP is fed to the PS module which produces regulated +10 and -15 V and supplies them to the BOOSTER AMP module under the condition of PWR of the MDP is ON.

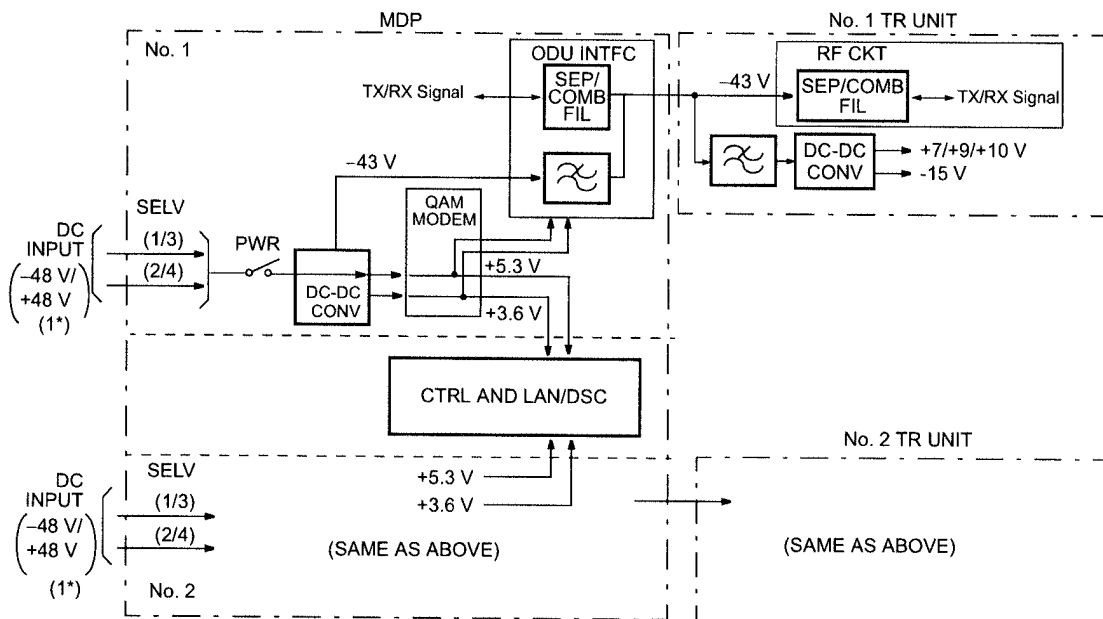

Note: The common (CTRL and LAN/DSC) modules are supplied DC power from the DC-DC CONV modules of both No. 1 and No. 2 to protect the system.

(*1) -20 V to -60 V / +20 V to +60 V type is applicable, too.

Fig. 2-14 Power Supply System Block Diagram

This page is intentionally left blank.

3. SUBSYSTEM DESCRIPTION

Described herein are composition and functional operation of each module of the MDP and the TRP.

MDP Equipment

3.1 Composition

The following equipment are composed of appropriate plug-in units as listed in Table 3-2. The component unit/modules are arranged on a shelf as shown in Fig. 3-1 and Fig. 3-2.

- MDP-15MB5T-1A/B/C/D: 8 x DS1, Fixed bit rate type
- MDP-28MB7T-1A/B/C/D: 16 x DS1, Fixed bit rate type
- MDP-50MB6T-1A/B/C/D: 1 x DS3, Fixed bit rate type
- MDP-50MB6T-2C/D: 28 x DS1, Fixed bit rate type

Table 3-1 Type of MDP

Code No.	Equipment Name	Capacity	Modulation	System
H0763A	MDP-15MB5T-1A	8 x DS1	32 QAM	1+1
NWA-025655-001	MDP-15MB5T-1C	8 x DS1 + LAN	32 QAM	
H0763B	MDP-28MB7T-1A	16 x DS1	128 QAM	
NWA-025655-002	MDP-28MB7T-1C	16 x DS1 + LAN	128 QAM	
NWA-025655-004	MDP-50MB6T-2C	28 x DS1 + WS/LAN	64 QAM	
H0763C	MDP-50MB6T-1A	1 x DS3	64 QAM	
NWA-025655-003	MDP-50MB6T-1C	1 x DS3 + WS/LAN	64 QAM	
H0938A	MDP-15MB5T-1B	8 x DS1	32 QAM	1+0
NWA-025656-001	MDP-15MB5T-1D	8 x DS1 + LAN	32 QAM	
H0938B	MDP-28MB7T-1B	16 x DS1	128 QAM	
NWA-025656-002	MDP-28MB7T-1D	16 x DS1 + LAN	128 QAM	
NWA-025656-004	MDP-50MB6T-2D	28 x DS1 + WS/LAN	64 QAM	
H0938C	MDP-50MB6T-1B	1 x DS3	64 QAM	
NWA-025656-003	MDP-50MB6T-1D	1 x DS3 + WS/LAN	64 QAM	

Table 3-2 MDP Composition (1/4)

Location No.*	Unit Name	MDP-15MB5T-1A	MDP-28MB7T-1A	MDP-50MB6T-1A	Remarks
1	H0766A/E SW UNIT	√	—	—	
	H0766B/F SW UNIT	—	√	—	
	H0766C/G SW UNIT	—	—	√	
2	H0936A/D MD UNIT	√	—	—	No. 1 CH
	H0936B/E MD UNIT	—	√	—	
	H0936C/F MD UNIT	—	—	√	
3	H0936A/D MD UNIT	√	—	—	No. 2 CH
	H0936B/E MD UNIT	—	√	—	
	H0936C/F MD UNIT	—	—	√	
4	H0935A CODE CONV	√	√	—	optional
5	H0934B LAN INTFC	—	—	—	optional

- Notes: 1. √ : Applicable, — : Not Applicable
 2. *Location numbers are referred to those in Fig. 3-1.
 3. H0766E/F/G: SC LAN (optional) is applicable.
 4. H0936D/E/F: It is possible to mount onto the 1+0 shelf.

Table 3-2 MDP Composition (2/4)

Location No.*	Unit Name	MDP-15MB5T-1B	MDP-28MB7T-1B	MDP-50MB6T-1B	Remarks
1	H0766A/E SW UNIT	√	—	—	
	H0766B/F SW UNIT	—	√	—	
	H0766C/G SW UNIT	—	—	√	
2	H0936D MD UNIT	√	—	—	
	H0936E MD UNIT	—	√	—	
	H0936F MD UNIT	—	—	√	
3	H0935A CODE CONV	√	√	—	optional
4	H0934B LAN INTFC	—	—	—	optional

Notes: 1. √ : Applicable, — : Not Applicable

2. *Location numbers are referred to those in Fig. 3-2.

Table 3-2 MDP Composition (3/4)

Location No.*	Unit Name	MDP-15MB5T-1C	MDP-28MB7T-1C	MDP-50MB6T-1C	MDP-50MB6T-2C	Remarks
1	H0766J SW UNIT	√	—	—	—	
	H0766K SW UNIT	—	√	—	—	
	H0766L SW UNIT	—	—	√	—	
	H0766M SW UNIT	—	—	—	√	
2	H0936D/G MD UNIT	√	—	—	—	No. 1 CH
	H0936E/H MD UNIT	—	√	—	—	
	H0936F/J MD UNIT	—	—	√	√	
3	H0936D/G MD UNIT	√	—	—	—	No. 2 CH
	H0936E/H MD UNIT	—	√	—	—	
	H0936F/J MD UNIT	—	—	√	√	
4	H0935A CODE CONV	√	√	—	—	optional
	NWA-025664-001 SUB INTFC	—	—	—	√	optional
5	RF SW CTRL	√	√	√	√	
6	H0934B LAN INTFC	√	√	√	√	optional

Notes: 1. √ : Applicable, — : Not Applicable

2. *Location numbers are referred to those in Fig. 3-1.

Table 3-2 MDP Composition (4/4)

Location No.*	Unit Name	MDP-15MB5T-1D	MDP-28MB7T-1D	MDP-50MB6T-1D	MDP-50MB6T-2D	Remarks
1	H0766J SW UNIT	√	—	—	—	
	H0766K SW UNIT	—	√	—	—	
	H0766L SW UNIT	—	—	√	—	
	H0766M SW UNIT	—	—	—	√	
2	H0936D/G MD UNIT	√	—	—	—	
	H0936E/H MD UNIT	—	√	—	—	
	H0936F/J MD UNIT	—	—	√	√	
3	H0935A CODE CONV	√	√	—	—	optional
	H0770A 1.5M SUB INTFC	—	—	—	√	optional
4	H0934B LAN INTFC	√	√	√	√	optional

Notes: 1. √ : Applicable, — : Not Applicable

2. *Location numbers are referred to those in Fig. 3-2.

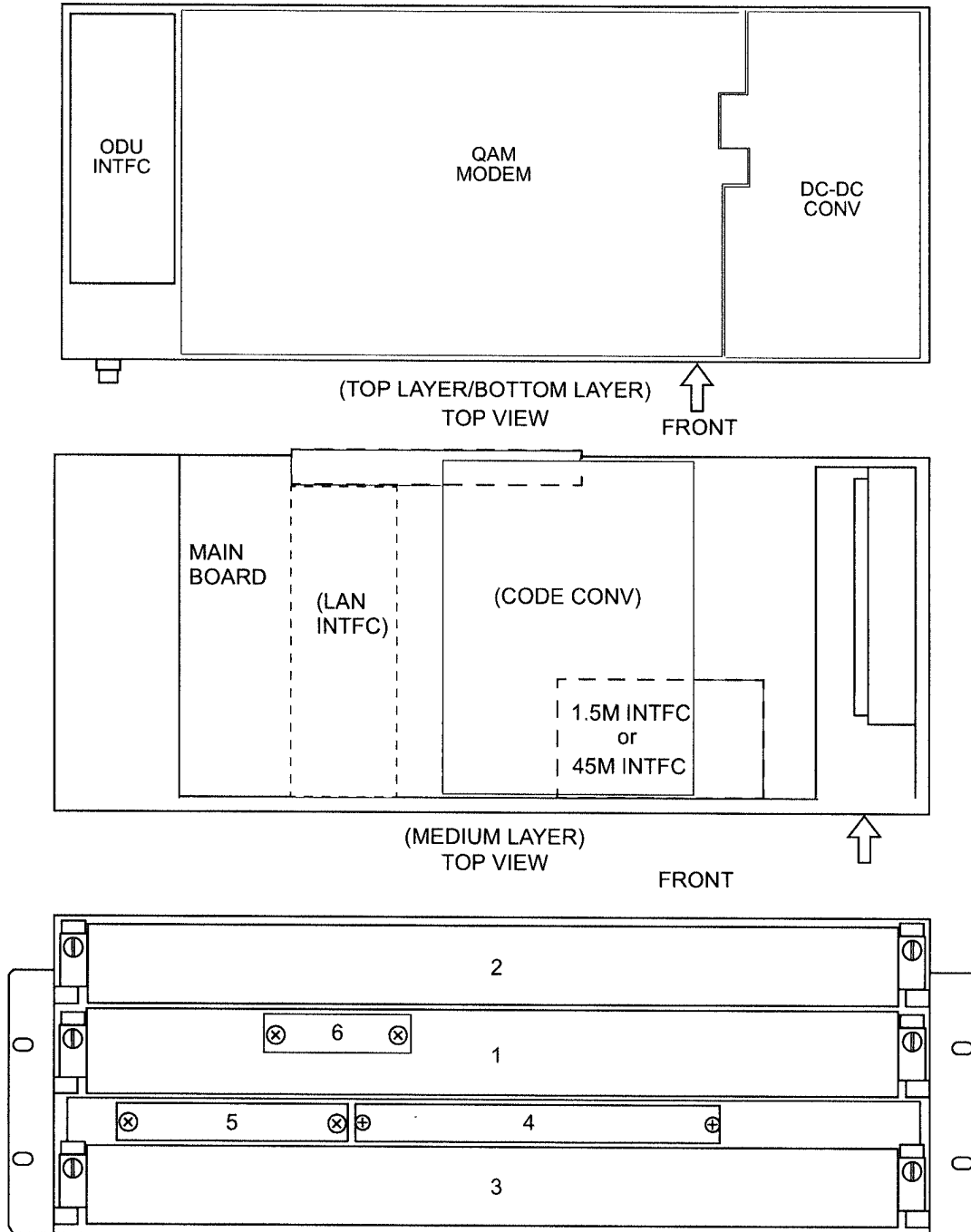

Notes: 1. Location numbers are referred to those in Table 3-2.

Fig. 3-1 MDP Component Unit/Module Arrangement (1+1)

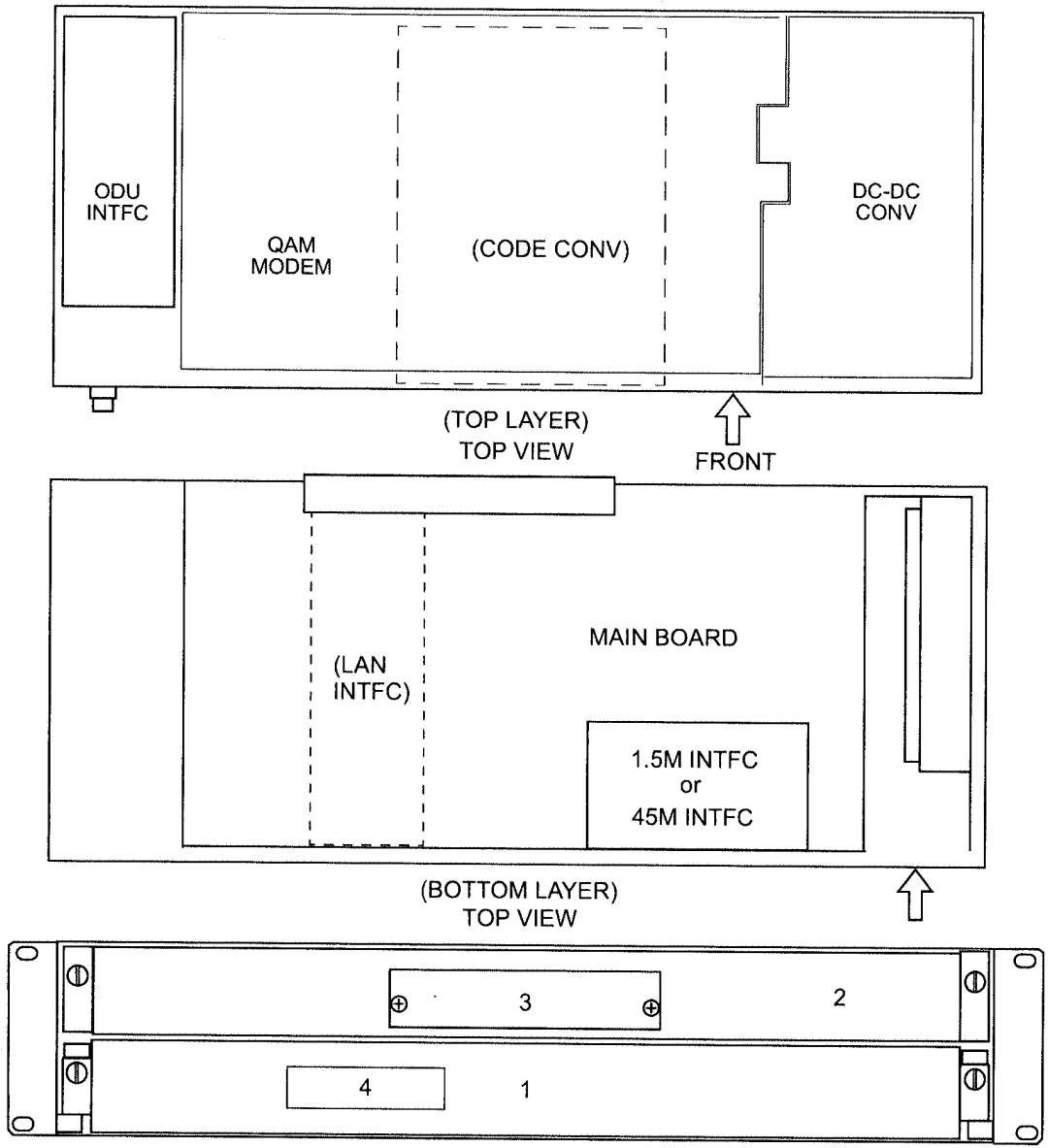

Notes: 1. Location numbers are referred to those in Table 3-1.

Fig. 3-2 MDP Component Unit/Module Arrangement (1+0)

3.2 Functional Operation

A block and level diagram of the MDP is shown in Fig. 3-3. Functional operations of the TRP are described separately for the modulator section and demodulator section.

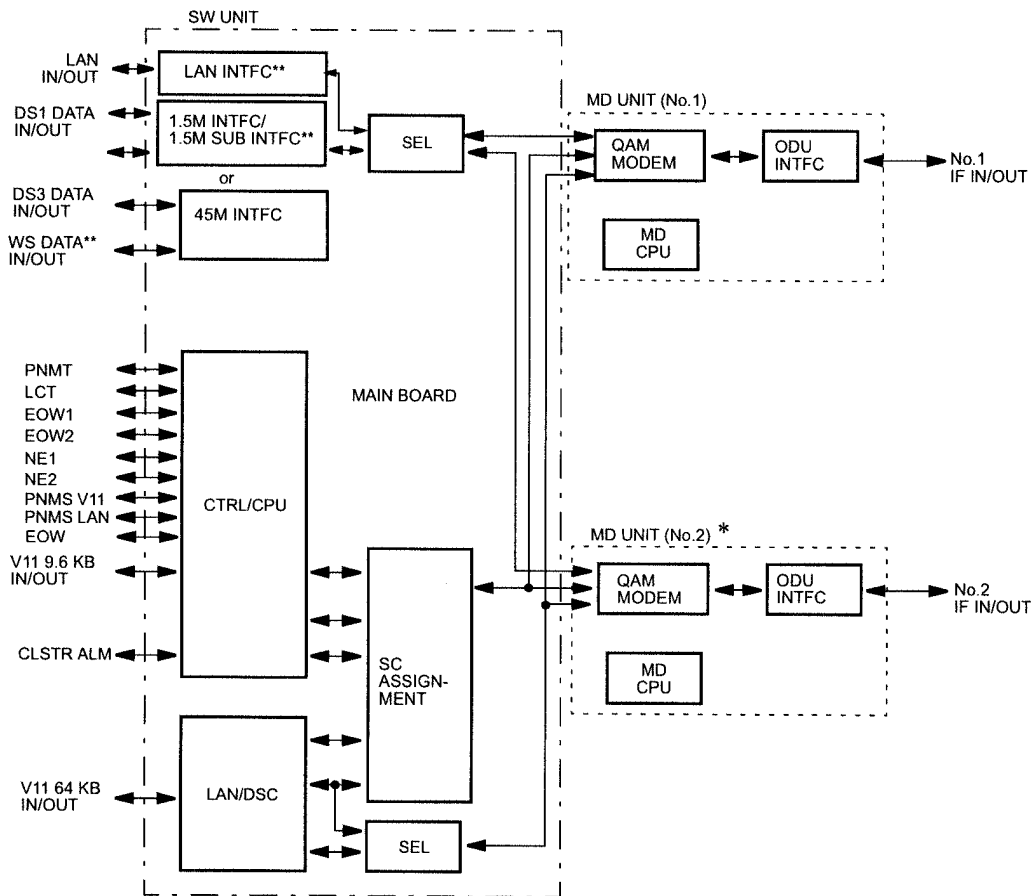

Notes: 1. The recommended cable, 8D-FB, has 15 dB (at 140 MHz)/26 dB (at 340 MHz) loss at the maximum length of 300 meters (1,000 feet).

2. * Not provided for 1+0 system.

3. ** Optional

Fig. 3-3 MDP Block and Level Diagram

3.2.1 Modulator Section

The DS1 (or DS3) signals received from the terminal equipment enter the 1.5M INTFC (or 45M INTFC) module in the SW UNIT. The 1.5M INTFC (or 45M INTFC) extracts the clock component from the data signal. Then the code format of 1.5M signal is converted from B8ZS or AMI (or 45M signal is converted from B3ZS) into Non-Return-To-Zero (NRZ) with extracted clock signal and fed to the QAM MODEM module.

In the QAM MODEM module, the data signal is speed-converted into radio frame format and time slots are made. Then additional bits for the digital service channel (DSC), orderwire (OW) and supervisory (SV) signals are inserted into the time slots. Moreover, error correction FEC bits are inserted, coded and string-converted into the data signal rows for modulation. The signal is then modulated with local oscillator signal into a 340 MHz IF signal, and is fed to the ODU INTFC module.

In the ODU INTFC module, the 340 MHz IF signal is multiplexed with the DC power and control signal, etc. which are fed to the TRP after the undesired amplitude-frequency characteristics due to the IF line cable is compensated.

3.2.2 Demodulator Section

At the ODU INTFC module, the control signal is separated from the 140 MHz IF signal received from the TRP. 140 MHz IF signal is fed to the QAM MODEM module after the undesired amplitude-frequency characteristics due to the IF line cable length and the signal level are compensated.

The 140 MHz IF signal from the ODU INTFC module is demodulated at the QAM MODEM module, then regenerated to the baseband signal composed of the radio frame. After the detection and correction of errors that occurred through the radio link are corrected, and radio frame synchronization is established. Then the DSC, WS, OW and SV signals inserted in the transmitter side are extracted from the time slots. The time slots for additional bits are removed, and fed to the 1.5M INTFC module.

The NRZ-coded data signal is converted into the original DS1 B8ZS or AMI data signal and fed to terminal equipment.

TRP Equipment

The composition and functional operation of the TRP are described in this chapter.

3.3 Composition

The component units and modules are arranged on the shelf as shown in Fig. 3-4 to Fig. 3-6.

Table 3-3 TRP Composition

Type	Code No.	Equipment Name	Frequency Range	TR UNIT
Split	H2600	TRP-6G-6AA	5725-5850 MHz	1TR
			5925-6425 MHz	1TR
			6525-7125 MHz	1TR
	H0998A	TRP-10G-2AA	10550-10680 MHz	1TR
	G8737B	TRP-11G-1AA	10700-11700 MHz	1TR
	NWA-027874-001	TRP-24G-2B	25250-25250 MHz	1TR
All Indoor e/w FAN	H2430B/D	TRP-L6G-2F	5925-6425 MHz	2TR
	NWA-023983-001	TRP-L6G-101A	5925-6425 MHz	4TR
	NWA-017306-001	TRP-U6G-101A	6525-7125 MHz	4TR
	NWA-017221-002	TRP-U6G-102A	6525-7125 MHz	2TR
	NWA-017224-001	TRP-10G-101A	10550-10680 MHz	4TR
	NWA-017303-001	TRP-11G-101A	10700-11700 MHz	4TR
	NWA-017227-002/4	TRP-11G-102A	10700-11700 MHz	2TR
All Indoor w/o FAN	H1304A	TRP-U6G-3AA	6525-7125 MHz	2TR
	H1306A	TRP-11G-3AA	10700-11700 MHz	2TR

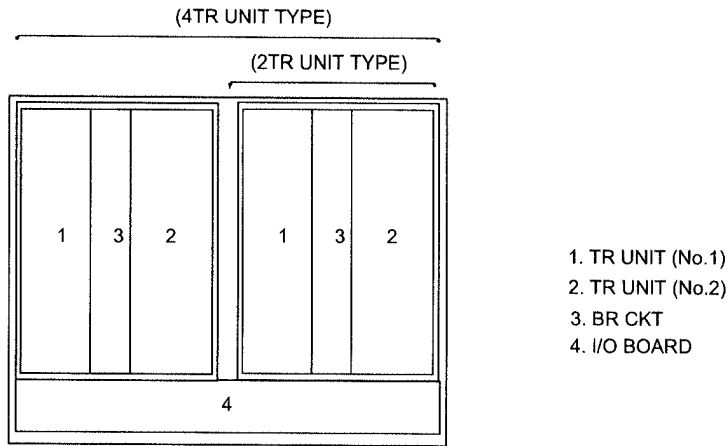

Fig. 3-4 TRP Component Unit Arrangement (e/w FAN Type) (1/2)

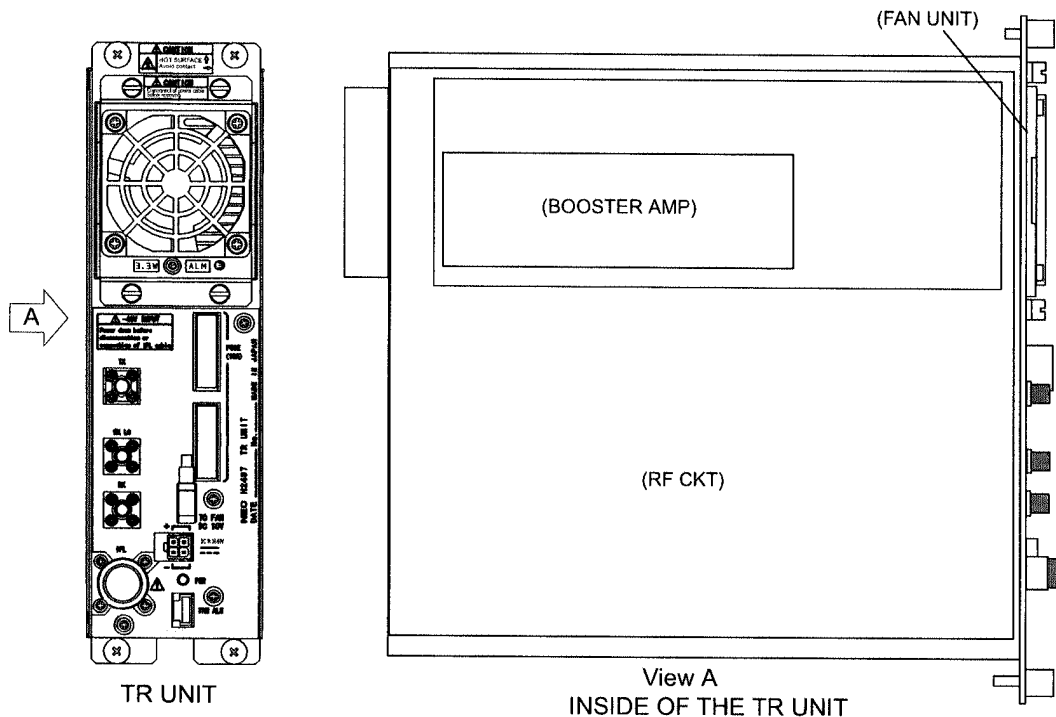

Fig. 3-4 TRP Component Module Arrangement (e/w FAN) (2/2)

Table 3-3 TRP Composition (e/w FAN Type)

Equipment Name	Unit Name		TX Power	Freq. Domain	DC Power	
TRP-L6G-2F	H2497A	TR UNIT	High	L	48 V	
	H2497B		High	H		
	H2497C		STD	L		
	H2497D		STD	H		
	H2326B	I/O BOARD	—	—	—	
	Unit Name		BAND WIDTH	System		
	H2503A	BR CKT	Wide	1+0		
	H2503B			1+1, HS/HS (3 dB HYB)		
	H2503C			1+1, HS/HS (10 dB CPL)		
	H2503D			1+1, HS/SD		