

## Cordless Terminal User' s Guide

---

DTL-12BT-1(BK) TEL

ITL-12BT-1(BK) TEL

BCH-L(BK) UNIT

- Before using your product, read this User' s Guide thoroughly to ensure correct handling.
- After reading the User' s Guide, keep it in a place that is accessible for read reference.

# LIABILITY DISCLAIMER

NEC Infrontia Corporation reserves the right to change the specifications, functions, or features, at any time, without notice.

NEC Infrontia Corporation has prepared this document for use by its employees and customers. The information contained herein is the property of NEC Infrontia Corporation and shall not be reproduced without prior written approval from NEC Infrontia Corporation. All brand names and product names on this document are trademarks or registered trademarks of their respective companies.

Copyright 2007

**NEC Infrontia Corporation**

---

---

---

---

---

---

## **Warning**

- ◆ Do not use the unit when you notice smoke, strange smell or other unusual happenings. It may cause fire if you continuously use them. Turn off the power switch of the phone system immediately. For the recharger, disconnect the power plug immediately. Confirm that smoke is ceased, and then contact the nearest NEC service office.  
Never attempt to repair those units by yourself.
- ◆ If you had an accident such as dropping the phone and broke the unit, turn off the power of the phone system immediately. For the recharger, disconnect the power plug immediately. Contact the nearest NEC service office.  
If you keep using those units, they may cause fire or electrical shock.
- ◆ If water smeared into the unit, turn off the power of the phone system immediately. For the recharger, disconnect the power plug immediately. Contact with the nearest NEC service office. If you keep using those units, they may cause fire or electrical shock.
- ◆ Do not insert flammable or metal objects into the units. If a foreign object were accidentally placed into the units, turn off the power of the phone system and plug out the power adapter. Contact the nearest NEC service office. If you keep using those units, they may cause fire or electrical shock. Pay special attention to children to prevent from similar accidents.
- ◆ Do not attempt to disassemble nor modify the units. It may cause fire, electrical shock, or system malfunction.  
Modification by a user is prohibited by law.
- ◆ Do not open the units intentionally. It may cause electrical shock or system malfunction.  
Ask test adjustment, and repair of the units for the nearest NEC service office.
- ◆ Do not twist, put a heavy object, and push the phone system. Such actions may cause damage, fire, or injuries.
- ◆ Do not place a container with water such as a vase, a plant pot, a cup, cosmetics, chemicals, nor a small metal object. Splashing water over the units and foreign metal object inserted into the units may cause fire or electrical shock.
- ◆ Do not use the unit in a high humid area such as a bathroom or near a humidifier. They may cause fire, electrical shock, or system malfunction.
- ◆ Use the specified power adapter, which is attached to the unit. Other adapters may cause fire or system malfunction.

- 
- 
- 
- 
- 
- 
- ◆ Do not damage, or modify the power adapter cord. Do not kink, pull, twist, or bundle it. Do not put a heavy object or heat it. They may cause fire, electrical shock, or system malfunction. Contact the nearest NEC service office for a damaged adapter cord.
  - ◆ Do not touch the power plug with a wet hand. It may cause electrical shock or system malfunction.
  - ◆ Do not touch the units or replace a battery with a wet hand. It may cause electrical shock or system malfunction.
  - ◆ When you hear thunder during using the phone system outside, immediately stop using it and move to a safe place.
  - ◆ Do not use multiple plugs to a single outlet. It may cause fire or electrical shock.
  - ◆ Follow the instruction below when you use a battery pack. They may cause heating, explosion, and fire;
    - Do not put the battery pack into a microwave oven or a pressure chamber.
    - Do not use other batteries with this battery pack.
  - ◆ If the internal battery liquid clung to your skin or clothes, immediately rinse it with clean water to prevent chemical damage to your skin and clothes.
  - ◆ Do not use the phone or recharge the battery in a place where fire or explosion may occur.
    - This phone system does not have explosion protection. Do not use it where a flammable gas such as propane and gasoline are stored. Turn off the power of the phone immediately. Do not recharge the battery in such a place.
  - ◆ Do not use near microwave ovens, medical equipment and industrial equipment.

---

---

---

---

---

---

## ***User Safety Protocol***

**Important:** Read this information before using your DTL-12BT-1(BK) TEL, ITL-12BT-1(BK) TEL and BCH-L(BK) UNIT Handset.

Observe the following instructions to use this product safely, prevent you and other people from possible injury, and protect properties. Improper handling may cause heat, explosion, and fire.

### ***Danger***

- ◆ Recharge the battery with the matching battery charger (see battery label description).
- ◆ Use the battery only for this DTL-12BT-1(BK) TEL, ITL-12BT-1(BK) TEL and BCH-L(BK) UNIT handset system. Do not use it with other electrical devices.
- ◆ Keep the following warnings to prevent the battery pack from heating, explosion, and fire.
  - Do not throw the battery pack into fire.
  - Do not solder the battery pack directly.
  - Do not short the positive (+) and negative (-) terminal of the battery pack with metal.
  - Do not poke the battery nor smash it with hammer.
- ◆ Do not disassemble nor modify the battery pack. It has a safety circuit and a damaged circuit may cause heat, explosion, and fire.
- ◆ The internal liquid of the battery pack has strong acid. If the battery liquid gets into your eye, rinse your eye well with water and consult with a doctor.
- ◆ Do not use, leave, nor recharge the battery pack near fire or under the direct sunlight. High temperature may damage the internal safety circuit and may cause malfunction of the recharge, heat, explosion, or fire.

---

---

---

---

---

---

---

---

---

---

## ***FCC portion***

This equipment has been tested and found to comply with the limits for a Class B digital device, pursuant to Part 15 of the FCC rules. These limits are designed to provide reasonable protection against harmful interference in a residential installation. This equipment generates, uses, and can radiate radio frequency energy and, if not installed and used in accordance with the instructions, may cause harmful interference to radio communications. However, there is no guarantee that interference will not occur in a particular installation. If this equipment does cause harmful interference to radio or television reception, which can be determined by turning the equipment off and on, the user is encouraged to try to correct the interference by one or more of the following measures:

- Reorient or relocate the receiving antenna.
- Increase the separation between the equipment and receiver.
- Connect the equipment into an outlet on a circuit different from that to which the receiver is connected.
- Consult the dealer or an experienced radio/TV technician for help.

This device complies with Part 15 of the FCC Rules. Operation is subject to the following two conditions: (1) This device may not cause harmful interference, and (2) This device must accept any interference received, including interference that may cause undesired operation.

### **Caution:**

Any changes or modifications not expressly approved by the party responsible for product compliance could void the user's authority to operate the equipment.

## **RF Exposure Guidelines**

LO(BTC)B / LO(BTC)U

To comply with FCC RF exposure compliance requirements, a separation distance of at least 20 cm must be maintained between the antenna of this device and all persons. This device must not be co-located or operating in conjunction with any other antenna or transmitter.

LO(BTH)B / LO(BTH)U

To comply with FCC RF exposure compliance requirements, this device must not be colocated or operating in conjunction with any other antenna or transmitter.

LO(BTH)B or LO(BTH)U was tested with BELTCLIP(BTH)(BK). Use only this beltclip to ensure FCC Compliance. The use of third-party beltclips may not comply with FCC RF exposure compliance requirements, and should be avoided.

---

---

---

---

---

---

---

---

## **Industry Canada Portion**

### **Canada Regulatory Compliance Statement**

This Class B digital apparatus complies with Canadian ICES-003.  
Cet appareil numéroté de la classe B est conforme à la norme NMB-003 du Canada.

#### **For Customers in Canada**

This device complies with RSS 210 of Industry Canada (IC).

Operation is subject to the following two conditions:

- this device may not cause interference, and
- this device must accept any interference, including interference that may cause undesired operation of this device.

L'utilisation de ce dispositif est autorisée seulement aux conditions suivantes:

- il ne doit pas produire de brouillage et
- l'utilisateur du dispositif doit être prêt à accepter tout brouillage radioélectrique reçu, même si ce brouillage est susceptible de compromettre le fonctionnement du dispositif.

#### **Exposure to radio frequency radiation**

The installer of this radio equipment must ensure that the antenna is located or pointed such that it does not emit RF field in excess of Health Canada limits for the general population; consult Safety Code 6, obtainable from Health Canada's website at [www.hc-sc.gc.ca/rpb](http://www.hc-sc.gc.ca/rpb).

# Introduction

Thank you very much for purchasing our cordless terminal.

< Devices covered >

- DtermX Cordless Terminal DTL-12BT-1(BK) TEL
- IPtermX Cordless Terminal ITL-12BT-1(BK) TEL
- Bluetooth® Handset Cradle BCH-L(BK) UNIT

A cordless terminal is a multifunctional telephone with a portable handset that lets you originate calls and answer terminating calls from within a certain talking range.

A standard multifunctional telephone may have its handset replaced with a BCH-L UNIT to transform into a cordless terminal.

Each cordless terminal consists of the following devices:

- Bluetooth® Cradle : A multifunctional telephone unit to which a BTC is connected.
- Bluetooth® Handset : BTH

Instructions in this User's Guide focus on Bluetooth® handset operations. For instructions about handling the Bluetooth® cradle, refer to the user documentation that comes with your system.

## How This Guide Is Organized

Before Using the Product

Provides tips and hints on using the product safely and properly, and topics of prerequisite importance to using the cordless terminal.

Bluetooth® Handset Operations

Explains operating tips and the handset functions of the cordless terminal.

Troubleshooting

Explains how to deal with troubles that may occur while you use the cordless terminal and interpret the error messages that may be displayed in the Bluetooth® handset LCD.



# Table of Contents

Introduction .....	vi
How This Guide Is Organized .....	vi
Table of Contents .....	vii

---

## Before Using the Product ..... 1-1

---

About Cordless Terminals .....	1-2
Bluetooth® Cradle and Bluetooth® Handset .....	1-2
Key Functions .....	1-2
Talking Range .....	1-4
Charging .....	1-5
Replacing the Battery .....	1-6
In the Event of a Power Failure .....	1-7
If Security Features Are Used .....	1-7
Primary Specifications .....	1-8
Safety Precautions .....	1-10
Operating Instructions and Maintenance .....	1-14
Locating the Bluetooth® Cradle .....	1-14
Antenna .....	1-15
Radio Transmission .....	1-15
Radio Interference .....	1-16
Maintenance .....	1-16
Charging Terminals .....	1-17
Operation Following Power Feeding to the Bluetooth® Cradle .....	1-17
Component Names and Functions .....	1-18
Bluetooth® Cradle (BTC) .....	1-18
Bluetooth® Handset (BTH) .....	1-19
Bluetooth® Handset LCD Screen .....	1-20
Displayed Information .....	1-20
Explanations of Icons .....	1-22

Adjusting the Bluetooth® Handset .....	1-24
Configuring the Cordless Terminal .....	1-25
Configuring the Bluetooth® Cradle (BTC) .....	1-25
Configuring the Bluetooth® Handset (BTH) .....	1-27
Transforming the Standard Handset into a BCH-L(BK) UNIT ....	1-29
Wall-Mounting the Bluetooth® Cradle .....	1-35
Connecting a Headset .....	1-38
Pairing with a Bluetooth® Headset .....	1-38
Connecting a Wire Headset .....	1-40

---

## Bluetooth® Handset Operations .....

---

2-1

Caution .....	2-2
Bluetooth® Handset Functions .....	2-3
Key Lock .....	2-3

---

## Troubleshooting .....

---

3-1

Troubleshooting Tips .....	3-2
----------------------------	-----



# Before Using the Product

- About Cordless Terminals ..... 1-2
- Safety Precautions ..... 1-10
- Operating Instructions and Maintenance ..... 1-14
- Component Names and Functions ..... 1-18
- Bluetooth<sup>®</sup> Handset LCD Screen ..... 1-20
- Adjusting the Bluetooth<sup>®</sup> Handset ..... 1-24
- Configuring the Cordless Terminal ..... 1-25
- Transforming the Standard Handset into  
a BCH-L(BK) UNIT ..... 1-29
- Wall-Mounting the Bluetooth<sup>®</sup> Cradle ..... 1-35
- Connecting a Headset ..... 1-38



## About Cordless Terminals

A cordless terminal is a multifunctional telephone that interconnects its Bluetooth® cradle and Bluetooth® handset with each other using Bluetooth® wireless technology to maintain calls or perform other operations between them.

### Bluetooth® Cradle and Bluetooth® Handset

- The Bluetooth® cradle of a cordless terminal can be handled the same way as a telephone. Its Bluetooth® handset can be handled likewise, except for some of its features. If a particular feature of a Bluetooth® cordless terminal does not work, use the Bluetooth® cradle to enable it.
- If the Bluetooth® handset of a cordless terminal is out of service, return it to the Bluetooth® cradle to keep it charged at all times.
- Where multiple cordless terminals are set up, be careful to retain the pairing between the Bluetooth® cradle and Bluetooth® handset.

### Key Functions

The table below summarizes the key functions of a cordless terminal. For information about the functions of the multifunctional telephone itself, refer to the user documentation that comes with your system.



The ways you originate calls from the Bluetooth® headset and answer terminating calls may vary depending on the type of device you use.

Function		Description
Bluetooth® Cradle (BTC)	Bluetooth® headset call	You can register a Bluetooth® headset with the Bluetooth® cradle and use it. <ul style="list-style-type: none"><li>• Originating calls to an extension or central office line Press the headset call (call control) key twice briefly and perform a dialing operation from the telephone.</li><li>• Answering terminating calls Press the headset call (call control) key while a call terminates with a ring tone.</li></ul>

Function		Description
Blue-tooth® Cradle (BTC)	Bluetooth® headset call	<ul style="list-style-type: none"> <li>* For latest recommended product information, browse the following Web site: <a href="http://www.necinfrontia.co.jp/">http://www.necinfrontia.co.jp/</a></li> <li>* Try to use a headset of the recommended type to ensure that it connects to the cradle successfully and with the correctly matched sound volume.</li> <li>* The Bluetooth® headset cannot be used while you are talking with the Bluetooth® headset on. You cannot switch to the Bluetooth® headset to use while you are using the Bluetooth® handset, either.</li> <li>* The headset call control key allows you to only originate calls from the headset and answer terminating calls.</li> </ul> <p>Any other headset-specific functions are not supported.</p>
Blue-tooth® Handset (BTH)	LCD display	<p>A 20-position-by-2-line LCD screen displays the date, time, phone number and more.</p> <p>Icons, such as those designating the status of radio and the remaining battery voltage, appear on the first line.</p> <ul style="list-style-type: none"> <li>* LCD displays may not be produced depending on your system.</li> </ul>
	Line keys	<p>Allow the functions preprogrammed on line keys 1 to 8 in the Bluetooth® cradle to be used.</p> <ul style="list-style-type: none"> <li>* For the functions that are available with the Bluetooth® handset, refer to the user documentation that comes with your system.</li> </ul>
	Incoming call/charging lamp	Lights or blinks en calls terminate or the handset is charged.
	Key touch tone	Provides an audible verification of each click on a dial key.
	Tone type	<p>En calls terminate, a ring tone sounds from the speaker in the cordless terminal. The ring tone sounds in different ways depending on the status of the Bluetooth® handset:</p> <ul style="list-style-type: none"> <li>• Charging (handset returned to the cradle) Sounding from the speaker in the cradle only</li> <li>• Standby (handset removed from the cradle) Sounding from both the cradle and handset speakers</li> </ul>
	Volume/density control	Allows you to use the cursor keys and to adjust the receiver and ring tone volumes and the LCD contrast.

Function		Description
Blue-tooth® Handset (BTH)	Telephone function	Allows you to originate calls to an extension or central office line, answer terminating calls and more, all in Blue-tooth® handset operations.
	Hold/Transfer	Places calls on hold and forward them to another telephone.
	Histories of originating and terminating calls	Displays up to 10 originating and up to 10 terminating calls (up to 20 calls in total), including the latest calls. * This function may be inoperable or the number of calls that can be displayed may vary depending on your system.

## Talking Range

The Bluetooth® cradle and Bluetooth® handset can be separated from each other about 50m at the remotest as a line-of-sight distance. This talking range, however, may shorten depending on the office environment in which the cradle and handset are used; for example, they are used near a metal or concrete wall.

If the handset gets too remote from the Bluetooth® cradle, the antenna mark will disappear accompanied by an alarm tone.

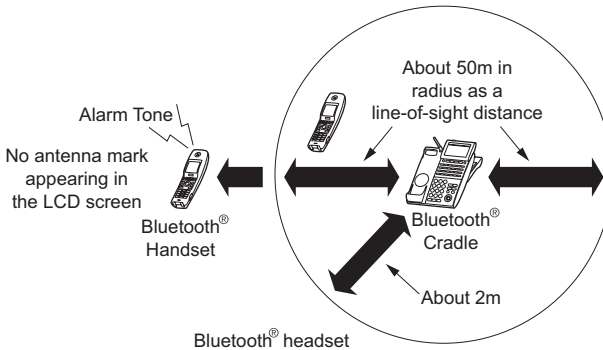





- You may have difficulty originating a call by dialing from the Bluetooth® handset. In this case, wait for a while and retry the dialing operation.
- Consult your dealer if you wish to use a cordless terminal together with an office cordless telephone in the same environment.

## Charging

Before you use the Bluetooth® handset for the first time or reuse the handset after it has been left out of service for a long time, charge it for at least 5 hours. (Full charging takes about 16 hours to complete.) A fully charged handset will allow you to talk for about 8 hours continuously and stand by for about 30 hours if low-power mode is enabled or for about 24 hours if low-power mode is disabled.

The remaining battery voltage icon appearing in the LCD screen, coupled by the incoming call/charging lamp and an alarm tone, alerts you to the remaining battery voltage of the Bluetooth® handset. The table below describes how these indications appear depending on the remaining battery voltage of the handset.

Remaining battery voltage	State indications			Remarks
	Icon	Incoming call/charging lamp	Alarm Tone	
High		-	-	
Medium		-	-	
Low		-	×	
Charging required		Blinking red	×	The handset can be used as long as the beep sounds.
Charging in progress	-	Fully charged : Lit green Charging : Lit red	-	
Charging error	-	Blinking orange	-	

## Replacing the Battery

The battery loaded in the Bluetooth® handset has a useful life of about 2 years, though it is a parameter of on how the handset has been used. If the battery voltage diminishes quickly after the battery has been charged for a long time, replace with a new battery (Li-ion BATTERY - option). For more details, ask your dealer.

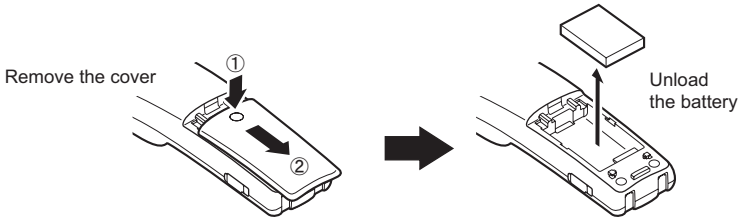

Li-ion

This product is powered by a lithium-ion battery.

Lithium-ion battery : 3.7V 1100mAh

The lithium-ion battery is a recyclable resource.

In recycling batteries that have been replaced or that have been unloaded from a used product, take notice of this precaution to avoid smoking and firing:

- Bring batteries to our repair counter with the contacts being taped to prevent shorts or enclosed individually in plastic bags.

<Our repair counter> For more details, visit the NEC Infrontia Environment Website.

**URL** <http://www.necinfrontia.co.jp/company/kankyo/index.htm>

Do not disassemble, tamper or damage the battery pack.

Please send your queries to:

- Dealer from whom your product or lithium-ion battery was purchased
- Our repair counter



## In the Event of a Power Failure

Your cordless terminal will behave in the following manners:

- The charging function is shut down to keep the system battery from draining depending on your system.
- The cordless terminal may be disabled depending on the system battery voltage.
- The cordless terminal is disabled if the system battery is exhausted.
- Calls in progress will be cleared if the system battery is exhausted in the meantime.
- If an optional AC adapter (AC-2RD UNIT) is used, the cordless terminal cannot be charged while the power failure persists.

## If Security Features Are Used

< On an IP multifunctional telephone only >

If security features are programmed on the system or on an IP multifunctional telephone, a security mode icon appears in the LCD screen of the Bluetooth® handset (BTH), with the following functions being locked:

- Logging of originating/terminating calls
- Setup menu

The security features can be canceled from the system or the Bluetooth® cradle only. Calls and other performance may be restricted depending on the security features. For more details, refer to the user documentation that comes with your system.

## Primary Specifications

Item	Dimension	Remarks
Bluetooth® version	Bluetooth® version 2.0	
Radio interface	Bluetooth® Class1	
Installed profiles	Bluetooth® Handset (BTH) <ul style="list-style-type: none"> <li>• GAP : Generic Access Profile</li> <li>• SPP : Serial Port Profile</li> <li>• HSP : Headset Profile</li> </ul>	
	Bluetooth® Cradle (BTC) <ul style="list-style-type: none"> <li>• GAP : Generic Access Profile</li> <li>• SPP : Serial Port Profile</li> <li>• HSP : Headset Profile</li> <li>• HFP : Hands Free Profile</li> </ul>	<p>* For latest recommended product information, browse the following Web site:  <a href="http://www.necinfrontia.co.jp/">http://www.necinfrontia.co.jp/</a></p> <p>* Try to use a headset of the recommended type to ensure that it connects to the cradle successfully and with the correctly matched sound volume.</p>
Operating range	About 50m (line-of-sight distance)	Dependent on the environment.
Power consumption	Bluetooth® Handset (BTH):About 0.5W	
	Bluetooth® Cradle (BTC) : About 1.5W	Including the power used to charge the handset.
Power feeding method	Power feeding from the multifunctional telephone	
Option	AC-2RD UNIT	Used only if the distance from the main unit exceeds 400m.
Dimensions (L × W × H)	Bluetooth® Handset (BTH): 180mm × 51mm × 33mm	Excluding the antenna.
	Bluetooth® Cradle (BTC): 175mm × 226mm × 92mm	
Weight	Bluetooth® Handset (BTH): About 200g	Including the battery.
	Bluetooth® Cradle (BTC): About 300g	Excluding the line cord, LAN cable.
Operating environment	Temperature : 0 to 40 Relative humidity : 10 to 90%	No dew condensing

Item	Dimension	Remarks
Restrictions		Keep the cordless terminal at least 1m apart from other cordless terminals and at least 3m apart from other radio equipment



Cordless terminals operate on a digital radio principle and are made less susceptible to interception by third parties. Radio waves used by the cordless terminals, however, threaten the chances of intentional interception. To dismiss concerns over possible interception by third parties, use a fixed-line telephone.

\* Bluetooth® is a registered trademark owned by Bluetooth SIG, Inc. and is licensed to NEC Infrontia Corporation.



## Safety Precautions

This User's Guide uses various pictorial markings to alert you to the precautions you need to observe to safeguard you and others and prevent property damage.

The meanings of such pictorial markings and graphic symbols are defined below. Understand these definitions fully before proceeding to read the main text.



### **DANGER**

- Indicates a situation in which an impending risk of human death or severe physical injury is anticipated.



### **WARNING**

- Indicates a situation in which a possibility of human death or severe physical injury is anticipated.



### **CAUTION**

- Indicates a situation in which a possibility of physical injury or property damage is anticipated.

### **NOTICE**

- Indicates a situation that could result in a failure to demonstrate the intended performance of this system or in a functional shutdown.

### ***Examples of Pictorial Markings***



The  $\triangle$  symbol alerts you to a caution (including a danger or warning), which is depicted within the marking (in this example, an electrical shock).



The  $\circ$  symbol alerts you to a prohibited action, which is depicted within the marking (in this example, no wetting).



The  $\bullet$  symbol alerts you to a required or suggested, which is depicted within the marking.

**DANGER**







- Observe these precautions en using a lithium-ion battery pack:
  - Never charge the pack from other than the main unit.
  - The lithium-ion battery pack has a specified connector orientation. In inserting the pack into the unit, observe the correct connector orientation.
  - Do not charge it with the lithium-ion battery pack unit.
  - Use a specified type of lithium-ion battery pack. Do not use the specified type of lithium-ion battery pack for any other device.
  - Do not dispose of the lithium-ion battery pack in fires or heat it.
  - Do not make direct soldering connections to the lithium-ion battery pack.
  - Do not disassembly or tamper the lithium-ion battery pack.
  - Do not carry or store the lithium-ion battery pack together with metallic products, which could cause the pack to leak, heat or blast.
- If the internal fluid in the lithium-ion battery pack should contact the eyes, it could threaten vision. Flush the eyes with plenty of fresh water immediately, without rubbing them, and obtain medical attention promptly.

**WARNING**





- Do not remove the armor of the lithium-ion battery pack or scratch it, which could cause the pack to leak, heat or blast.
- If the internal fluid in the lithium-ion battery pack should contact the skin or clothes, it could cause physical harm to the skin. Flush with plenty of fresh water immediately.
- Do not soak the lithium-ion battery pack in water or seawater or moisten it, which could cause the pack to heat or rust.
- Discontinue using the lithium-ion battery pack whenever any signs of abnormality, such as leakage, discoloration or deformation, are noticed.
- Do not use the lithium-ion battery pack in bathrooms or shower rooms, which could cause the pack to short-circuit, resulting in fires or electrical shock hazards.
- Do not use the lithium-ion battery pack ere it may be splashed or wetted with water, which could cause the pack to short-circuit, resulting in fires or electrical shock hazards.









## **WARNING**

- Do not disassemble or tamper the unit, which could result in fires or electrical shock hazards. 
- Do not allow water inside the lithium-ion battery pack or wet it with water, which could cause the pack to short-circuit, resulting in fires or electrical shock hazards. 
- Do not operate or make connections to this unit with wet hands, which could result in electrical shock hazards. 
- Do not put flower vases, plant pots, cups, cosmetics, containers filled with chemicals or water or small metallic objects on top of the unit, which could result in fires or electrical shock hazards if they spill or penetrate the interiors of the unit. 
- Do not insert metallic objects or put metallic objects into the interiors of the unit through openings, which could result in fires, electrical shock hazards or failures. 
- If it is necessary to use an AC adapter, use one of the specified type; otherwise, fires, electrical shock hazards or failures could result. 

## **CAUTION**

- Do not give violent shocks to the lithium-ion battery pack or throw it. 
- Keep the lithium-ion battery pack out of reach of infants and children. 
- Do not leave the lithium-ion battery pack in a place exposed to direct sunlight or in a hot place. A heightened internal temperature could result in fires. 
- Do not place the unit in a place where it could be splashed with heated oils or exposed to steam, such as near a cooking table, or in a dusty place, which could result in fires or electrical shock hazards. 
- Do not mount the unit on a rickety table or in an inclined or unstable place, which could cause the unit to tumble down out of balance or fall to cause physical injury. 

## CAUTION

- Do not block ventilation holes in the unit, which could cause heat to build up inside the unit, resulting in fires. 
- Do not place the unit in a place that is liable to frequent vibration or impact, which could cause the unit to fall or tumble down, resulting in physical injury. 
- Be careful not to let the antenna of a cordless telephone or the like stick into your eyes by mistake. 
- Do not short-circuit the charging terminals. 
- Do not charge the handset seated in the cradle while the charging terminals are wet with water drops. 
- If foreign matter or water should penetrate the interiors of the telephone, disconnect the line cord, LAN cable and AC adapter immediately and contact your dealer. 

## NOTICE

- To use the unit safely and properly, avoid installing it in these places:
  - Places there is much dust or vibration.
  - Places that are filled vaporized chemicals or the unit may be exposed to chemicals.
  - Places close to radios or TV receivers or sources of intense magnetic fields.
  - Places in which there are sources of high-frequency interference nearby, such as high-frequency sewing machines or electric welders.

## Operating Instructions and Maintenance

In using cordless terminals, take notice of these instructions in particular.

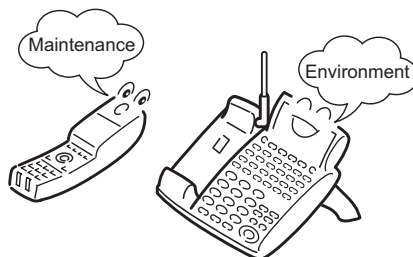

### Locating the Bluetooth® Cradle

- If multiple cordless terminals are installed, keep their Bluetooth® cradles at least 1m apart from one another.
- If the Bluetooth® cradle is installed near a metal, concrete wall or any other structure that could affect radio transmission, a communication failure might occur.
- Keep the Bluetooth® cradle at least 3m apart from any of the devices listed below. Be also careful not to get within 3m of these devices en using the Bluetooth® handset. Before locating the cradle, ask your dealer for a safety validation.
  - Microwave ovens
  - Wireless LAN access points (AP)
  - Medical apparatus
  - RFID (apparatus operating in the 2.4 GHz band)
  - Manufacturing equipment, such as plasma strippers (LSI manufacturing)
  - Speedway electronic toll gates
  - Bluetooth® devices

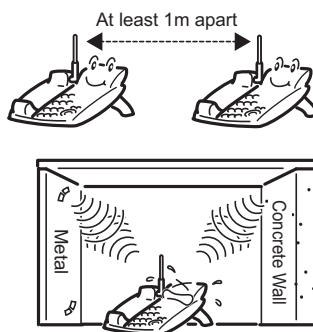



## Antenna

Use the antenna of the Bluetooth® cradle in an upright position. The antenna would be broken or bent if it is given undue force.

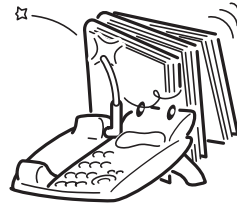

## Radio Transmission

Cordless terminals may not work or may be affected by interference if they are used near a broadcasting station or near sources of intense radio transmission, such as ham radio and CB radio. Because radio equipment might be disabled in the presence of radio interference, ask your dealer for preliminary environmental measurement. In installing new radio equipment after the system has been installed as well, request a preliminary verification of freedom from radio interference. If interference is detected after the system is installed, they may not be corrected.

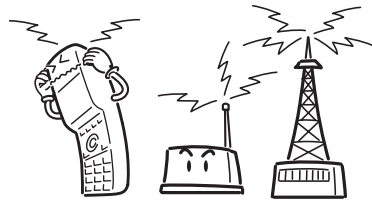

### **Tips on Radio Transmission**

The working frequency band of this device is shared by industrial, scientific and medical equipment, such as microwave ovens, premises radio stations that are typically used in manufacturing lines at plants for mobile identification (radio stations that require licensing) and specified low-power radio stations (license-free radio stations).

- Before using this device, check that premises radio stations for mobile identification and specified low-power radio stations are not used nearby.
- If any case of radio interference arises from a premises radio station used for mobile identification, discontinue radio transmission from this device immediately and contact your dealer for advice on how to take action for avoiding the interference.
- Further, if any case of radio interference arises from a specified low-power radio station used for mobile identification or any troubles develop, contact your dealer.

### **Radio Interference**

Cordless terminals are designed to heighten radio output automatically as the separation between the Bluetooth® cradle and Bluetooth® handset widens, thereby maintaining a satisfactory state of communication.

Heightened radio output could cause radio interference to neighboring equipment. In this occurs, keep the Bluetooth® cradle farther apart from the neighboring equipment.

### **Maintenance**

If the Bluetooth® cradle and Bluetooth® handset get dirty, wipe their surfaces with a soft, dry cloth. If they are heavily soiled, wipe them with a diluted solution of a kitchen detergent and then wipe them off with a dry cloth.

Never use organic solvents, such as alcohol, benzene and thinner, for cleaning; these chemicals could damage the surfaces of the telephone.

Also, avoid using a chemical duster.

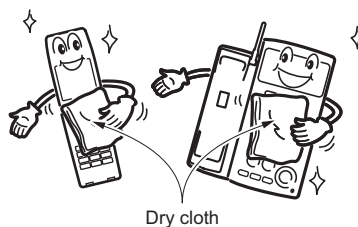

## Charging Terminals

Keep the charging terminals of the Bluetooth® cradle and Bluetooth® handset always clean. Wipe dust off the charging terminals with a dry cotton swab or the like at least once a month or rub them with a cotton swab or the like impregnated with alcohol.

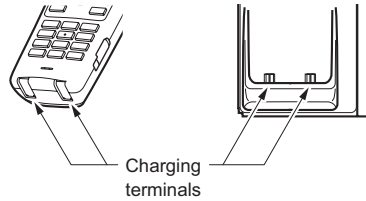

In cleaning the charging terminals, be sure not to:

- Touch the terminals with hands directly
- Short-circuit the terminals.

## Operation Following Power Feeding to the Bluetooth® Cradle

Because cordless terminals use radio transmission between their Bluetooth® cradle and Bluetooth® handset, they may take about 15 seconds after the line cord/LAN cable is instead into the Bluetooth® cradle before calls can be made between the Bluetooth® cradle and Bluetooth® handset.

If the Bluetooth® handset goes off-hook or the FNC/Conference or TALK key is pressed in the meantime, the error tone “pi-pi-pi-pi” may sound without a wireless (line) connection being established, but this is not a fault.

# Component Names and Functions

The names and functions of the components of a cordless terminal are shown below.

## Bluetooth® Cradle (BTC)

Security key

Use to enable the security features.  
\* The security key is not available on some types of telephone.

Large lamp

Indicates the status of a terminating call.

Antenna

Charging terminals

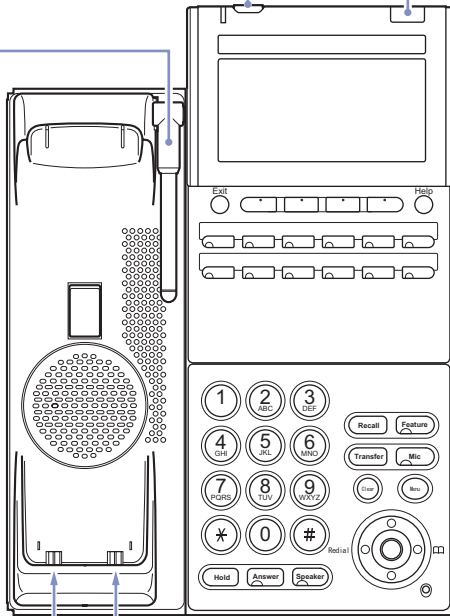

# Bluetooth® Handset (BTH)

**Incoming call/charging lamp**  
Indicates the status of a terminating call and in progress, and the status of charging.

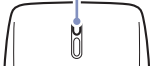

**Back**

**Headset jack**  
Accepts a wire headset.



**Right side**

**Corsur key**  
[▲] ~ [▼] Volume Up/Down key:  
Use to adjust tone volumes or display densities.

[📞] Received History key:  
Use to view a history of terminating calls.

[📞] Call History key:  
Use to view a history of originating calls.

[○] Enter key:  
Use to accept the terminating or originating call history displayed in the LCD screen or and make a call.

[TRF] Transfer key  
Use to forward a call to an extension or central office line.

[FNC/CONF] FNC/Conference key (with lamp)  
Use to call an extension or answer a call. This key can also be used to on the man unit as a FNC (function key) key. A setting on the man unit is required to use this key as a FNC key. For more details, refer to the user documentation that comes with your system.

[📞] TALK key (with lamp)  
Use to originate a call to an extension or central office line or answer a terminating call.

LCD screen (with backlight)  
Displays various information according to the status of the telephone, such as a clock, remote party information, originating and terminating call histories and menus.

[1] ~ [8] Line keys 1 to 8 (with lamp)  
Access the functions preprogrammed on function buttons 1 to 8 on the cradle. Also display the status of the functions preprogrammed on the buttons.

[HOLD] HOLD key  
Use to place extension or central office line calls on hold.

[Recall] Recall key  
Use to forward calls on a private exchange (PBX) or receive the call waiting service feature.

[📞] END key (Disconnect)  
Use to clear a call.

[@ 1] ~ [#] Dial keys 1 to # (with backlight)

Charging terminals



# Bluetooth® Handset LCD Screen

The Bluetooth® handset LCD screen displays certain information as described below according to the status of the telephone. For information about the Bluetooth® cradle LCD screen, refer to the user documentation that comes with your system.

## Displayed Information

### ▼ Standby Sample Display

The information shown below is displayed on the telephone and is not used.



First line  
Second line  
Third line  
Fourth line

- First line : Icon
- Second line : Date and time
- Third line : Extension number and line
- Fourth line : Active line key number

For explanations of the icons, see “Explanations of Icons” (P.1-22).

## ▼ If an Originating or Terminating Call History Is Displayed

If an originating or terminating call history is displayed, the history number of a call and date and time are displayed, along with the remote party's name or telephone number.

<Originating call history>

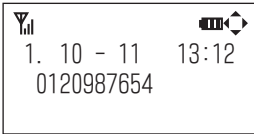

<Terminating call history>

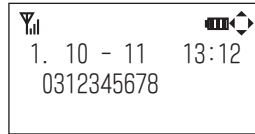

The display may differ depending on your system.

## ▼ If the Setup Screen Is Displayed

If the Setup Screen is displayed, the title of a setup item and its setting are displayed. For more details, see “Configuring the Bluetooth® Handset (BTH)” (P.1-27).

<Volume/density control>





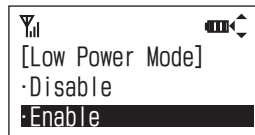





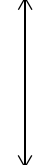



<Item selection>





## Explanations of Icons

The table below summarizes the explanations of the icons that appear on the first and fourth lines in the LCD screen.

Icon	Explanation		
	Antenna marks	High  Low  No service	Indicates the strength of radio transmission between the Bluetooth® cradle and Bluetooth® handset. * If no service occurs while a call is in progress, the call is cleared after about 20 seconds expire. The call can last if it recovers from no service before it is cleared. * No service (no display) indicates that the telephone is out of reach of radio transmission. Move to a place where an antenna mark lights.
			
			
			
			
	Security mode		Displayed on the telephone is locked in security key. * Available only if the Bluetooth® cradle is an IP multifunctional telephone.
	Ring tone OFF		Displayed on the telephone is configured to suppress the ring tone. For more details, see “Ring Volume” in “Configuring the Bluetooth® Handset (BTH)” (P.1-27).
	Unread instant message notification		Displayed on there are instant messages (IM) yet to be read. * Available only if the Bluetooth® cradle is an IP multifunctional telephone.
	Unheard voice mail notification		Displayed on there are voice mails in the mailbox yet to be heard.
	Key lock		Displayed on a key lock has been set. For more details, see “Key Lock” (P.2-3)
	Unanswered call history yet to be confirmed		Displayed on there is a history of unanswered terminating messages yet to be confirmed.
	Remaining battery voltage		Indicates the remaining voltage of the battery. For more details, see “Charging” (P.1-5).



Icon	Explanation	
	Available cursor display	Indicates the directions of the cursor keys available.
	Line key status display	Indicates the numbers of active line keys.

# Adjusting the Bluetooth® Handset

You can adjust the volumes of various tones and the display density of the Bluetooth® handset using the up and down cursor keys.

## ▼ Adjusting the Receiver Volume

You can adjust the volume of the voice that is heard from the handset.

Press the up and down cursor keys (up: high, down: low) while you are talking on the handset.



## ▼ Adjusting the Ring tone Volume

You can adjust the volume of the ring tone of the Bluetooth® handset.

Press the up and down cursor keys (up: high, down: low) while the ring tone sounds.

If you want to adjust the ring tone volume while the ring tone does not sound, do as instructed in “Ring Volume” in “Configuring the Bluetooth® Handset (BTH)” (P.1-27).

The ring tone OFF icon appears in the LCD screen if the ring tone volume is turned off.

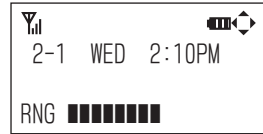

## ▼ Adjusting the LCD Density

You can adjust the contrast of the LCD screen.

Press the up and down cursor keys (up: dark, down: light) while the standby panel is on display.



# Configuring the Cordless Terminal

## Configuring the Bluetooth® Cradle (BTC)

Start configuring Bluetooth® from the cradle setup menu.

The table below lists the setting of each setup item.

Menu display		Setting ([ ] default)	Explanation
Pairing Mode	Pairing	-	Up to 8 Bluetooth® devices located around the Bluetooth® cradle (BTC) are located, among which select a headset want to pair with the multi-functional telephone. For more details, see “Pairing with a Bluetooth® Headset” (P.1-38).
	PIN Code	4 to 16 digits [0000]	Before pairing, you need to adjust the PIN Code of the Bluetooth® cradle (BTC) and the Bluetooth® headset. In pairing with a Bluetooth® headset having a PIN Code other than 0000, enter a string of 4 to 16 digits to suit that device. For more details, see “Pairing with a Bluetooth® Headset” (P.1-38). * The PIN Code is a password that is exchanged between Bluetooth® devices preparatory to launching a session of communication between them.
Visibility		1. Disable [2. Enable]	Set ether to make information about the Bluetooth® cradle (BTC) visible to other Bluetooth® devices or not. • Disable : Invisible • Enable : Visible

Menu display	Setting ([ ] default)	Explanation
BT Information	-	<p>You can view the following kinds of information about the Bluetooth® cradle (BTC):</p> <ul style="list-style-type: none"> <li>• Firmware version</li> <li>• Hardware version</li> <li>• BT module</li> <li>• BT profile (Bluetooth® standard)</li> <li>• SPP (SPP profile version)</li> <li>• HSP (HSP profile version)</li> <li>• HFP (HFP profile version)</li> <li>• Device address</li> <li>• Device name</li> </ul>

### ▼ Key Operations at Menu Setup (Bluetooth® Cradle)

Key		Description
Cursor keys	Up	<ul style="list-style-type: none"> <li>• Moves up the highlighted item.</li> <li>• Raises the volume or density.</li> </ul>
	Down	<ul style="list-style-type: none"> <li>• Moves down the highlighted item.</li> <li>• Lowers the volume or density.</li> </ul>
	Left	<ul style="list-style-type: none"> <li>• Returns to the last page.</li> </ul>
	Right	<ul style="list-style-type: none"> <li>• Accepts the highlighted item and displays the next page.</li> </ul>
	Enter	<ul style="list-style-type: none"> <li>• Accepts the highlighted item and displays the next page.</li> <li>• Saves the change and returns to the last page.</li> </ul>
Dial keys		<ul style="list-style-type: none"> <li>• Accept the item of a number pressed and display the next page.</li> <li>• Save the change to a number pressed and return to the last page.</li> <li>• Enter numerals.</li> </ul>
Clear key		<ul style="list-style-type: none"> <li>• Returns to the last page.</li> <li>• Deletes one numeral.</li> </ul> <p>* The clear key is not available on some types of telephone.</p>
Exit key		<ul style="list-style-type: none"> <li>• Cancels an operation and returns to the standby panel.</li> </ul>



You cannot originate calls or answer terminating calls while the Bluetooth® menu setup is in progress. Exit the menu before originating calls or answering terminating calls.

## Configuring the Bluetooth® Handset (BTH)

On the Bluetooth® handset in standby mode, press the [HOLD] > [Transfer] keys and then press dial keys (1) to (6) to see a Setup Screen associated with the dial key pressed.

The table below lists the setting of each item.



The handset will return to the standby panel automatically if 4 minutes pass with the no action being launched from the menu.

Dial key	Item	Setting ([ ] default)	Explanation
(1)	Base Call	-	Allows you to call up the paired Bluetooth® cradle and identify it en it is unknown.
(2)	Key Touch Tone	<ul style="list-style-type: none"> <li>• Disable</li> <li>• [Enable]</li> </ul>	Set ether to sound a confirmation tone each time a key is pressed or not.
(3)	Ring Volume	Off (0), 1 to [8] to 13	Adjusts the ring tone volume. The ring tone OFF icon appears in the LCD screen if the ring tone volume is turned off.
(4)	No Service Tone	<ul style="list-style-type: none"> <li>• Disable</li> <li>• [Enable]</li> </ul>	Set ether to sound a no service tone en no service occurs.
(5)	Low Power Mode	<ul style="list-style-type: none"> <li>• Disable</li> <li>• [Enable]</li> </ul>	Set ether to transition to low-power mode automatically en no call or key operation has been launched for a long time.
(6)	Font Size	<ul style="list-style-type: none"> <li>• Double Height</li> <li>• [Normal]</li> </ul>	Set ether to display the characters on the two lines in the middle in the LCD screen in double or normal height. * Characters display in normal height while a setup item is on display.



You cannot originate calls or answer terminating calls while the Bluetooth® menu setup is in progress. Exit the menu before originating calls or answering terminating calls.

## ▼ Key Operations at Setup (Bluetooth® Handset)

Key		Description
Cursor keys	Up	<ul style="list-style-type: none"><li>• Moves up the highlighted item.</li><li>• Raises the volume or density.</li></ul>
	Down	<ul style="list-style-type: none"><li>• Moves down the highlighted item.</li><li>• Lowers the volume or density.</li></ul>
	Left	<ul style="list-style-type: none"><li>• Returns to the last page.</li></ul>
	Right	<ul style="list-style-type: none"><li>• Accepts the highlighted item and displays the next page.</li></ul>
	Enter	<ul style="list-style-type: none"><li>• Accepts the highlighted item and returns to the standby panel.</li></ul>
END key		<ul style="list-style-type: none"><li>• Cancels an operation and returns to the standby panel.</li></ul>

## Transforming the Standard Handset into a BCH-L(BK) UNIT

The BCH-L(BK) UNIT is an optional device that transforms the standard multifunctional telephone into a cordless terminal. This section explains how to transform the standard handset into a BCH-L(BK) UNIT.

### ▼ Supported Telephone Type

The BCH-L(BK) UNIT can be connected to the following types of telephone:

Telephone type	Description	Remarks
Digital multifunctional telephone	<ul style="list-style-type: none"> <li>• DTL-12/24/32D-1</li> <li>• DTL-32DLK-1</li> <li>• DTL-8LD-1</li> </ul>	Not connectable to the DTL-2E-1 and DTL-6DE-1.
IP multifunctional telephone	<ul style="list-style-type: none"> <li>• ITL-12/24/32D-1</li> <li>• ITL-32DLK-1</li> <li>• ITL-8LD-1</li> <li>• ITL-320C-1</li> </ul>	Not connectable to the DTL-2E-1 and DTL-6DE-1.



If the BCH-L(BK) UNIT is connected to a telephone, the following optional devices cannot be connected at the same time:

- APR-L UNIT
- ADA-L UNIT
- BHA-L UNIT
- PSD-L(WH) UNIT
- PSA-L(WH) UNIT

### ▼ Replacement Procedure

**1** Turn over the telephone.

**2** Remove the standard handset.

Release the coiled cord from the groove and out its modular plug from the HANDSET connector on the back of the telephone.

**3** Lower the tilt legs to the first level.

- 4** Release lugs a and b on the stopper from grooves A and B in the tilt legs and widen the tilt legs.

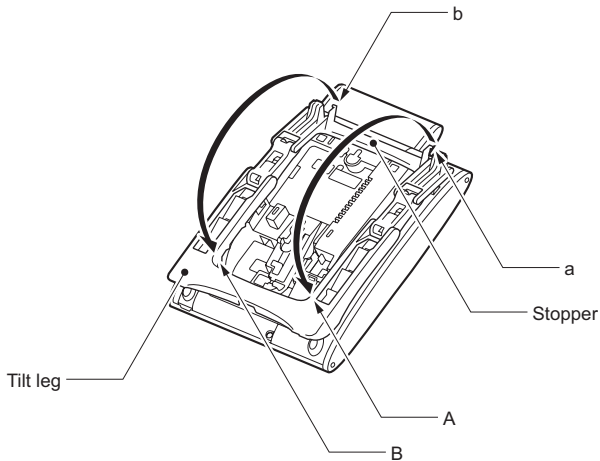

- 5** Slide the tilt legs to front out of position while pushing claws c and d.

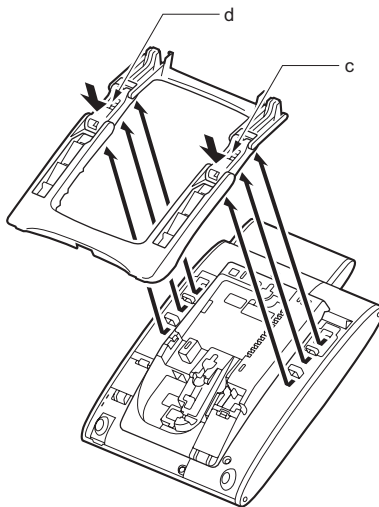



- 6** Tilt the handset cradle stopper towards the cradle until it is released with a click.
- 7** Slide the handset cradle farther away to remove.
- 8** Remove the cradle connecting cable from the telephone unit connector.

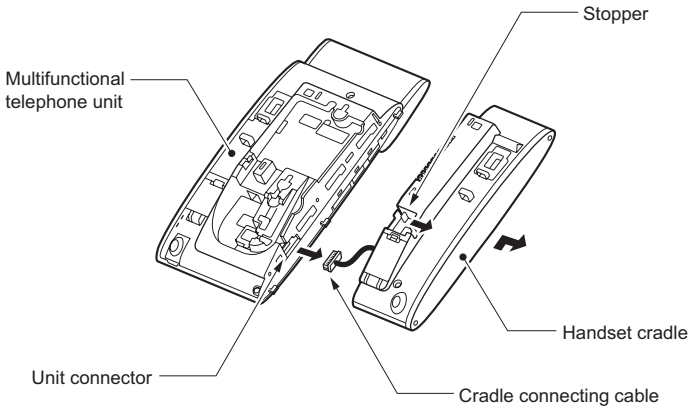

- 9** Insert the cradle connecting cable of the Bluetooth<sup>®</sup> cradle (BTC) into the telephone unit connector.
- 10** Insert the lug on the telephone unit into the hole in the Bluetooth<sup>®</sup> cradle (BTC).

Have the cradle connecting cable passed in the groove to keep it from being pinched.

**11** Slide the Bluetooth® cradle (BTC).

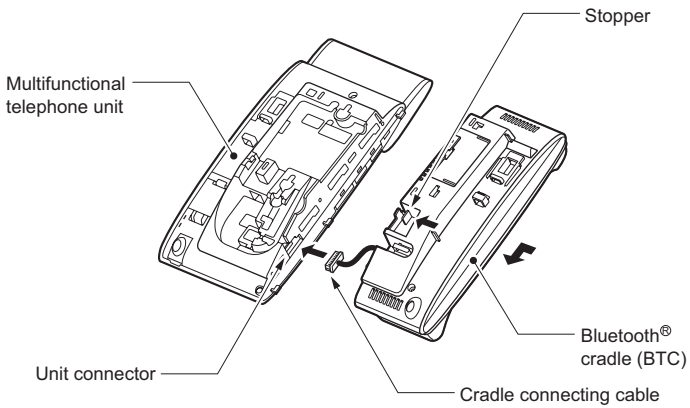

**12** Push the Bluetooth® cradle (BTC) until the stopper clicks into position.

**13** Fit the cradle connecting cable in the groove to clamp.

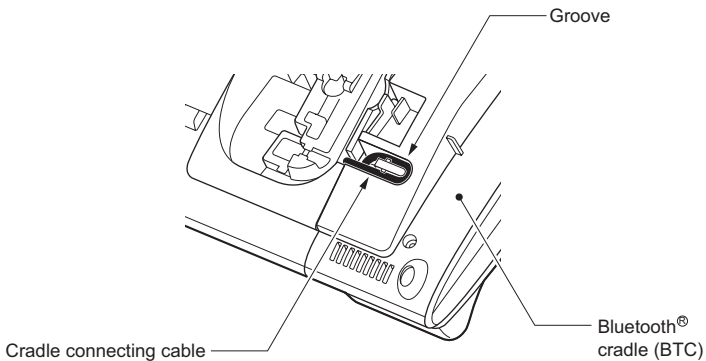

- 14** Cut out the notched section of the bottom unit connector on the multifunctional telephone with nippers or the like.

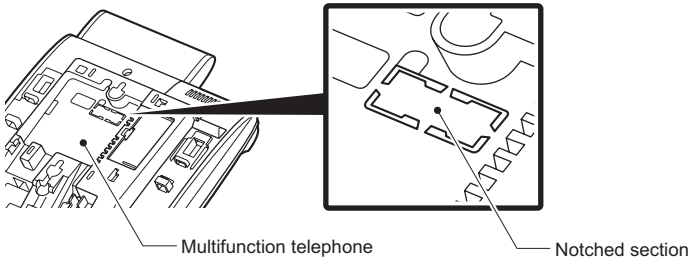

Cut out the notched section at its base to leave no legs.



- 15** Attach the bottom unit mounted in the Bluetooth<sup>®</sup> cradle (BTC) to the telephone connector while pushing the claws on both sides of the unit.

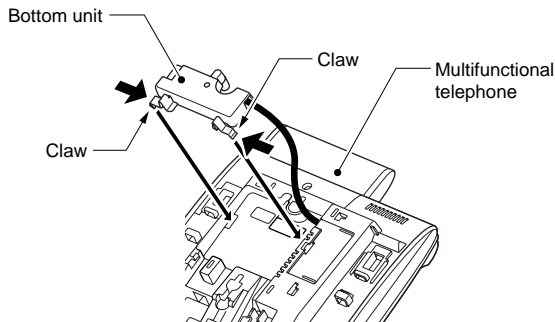

- 16** Uncover the bottom unit mounted in the Bluetooth<sup>®</sup> cradle (BTC) while holding its knob.

- 17** Stow the extra length of the bottom unit connecting cable at the bottom unit connector and close the bottom unit.

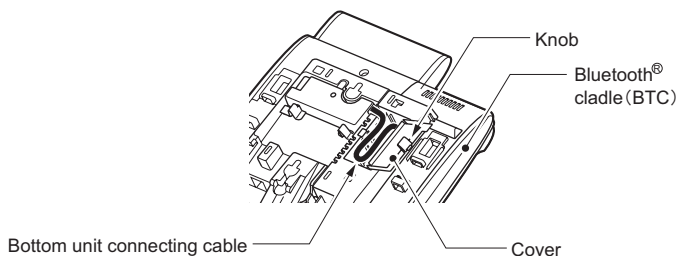

- 18** Widen the tilt legs until a click sounds.

- 19** The tilt legs in original position.

- 20** Place the Bluetooth® handset (BTH) in the Bluetooth® cradle (BTC).

- 21** Erect the antenna of the Bluetooth® cradle (BTC).

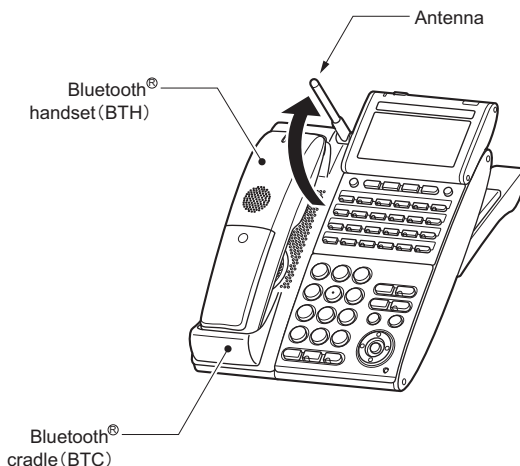

The transformation of the standard handset into a BCH-L(BK) UNIT is complete.

# Wall-Mounting the Bluetooth® Cradle

## ▼ Selecting a Mounting Position

### CAUTION

- When the cradle is wall-mounted, watch for its fall.
  - Physical injury could result.
- In wall-mounting the cradle, install it in firm position so it will not fall due its own weight.
  - Physical injury could result.



Clearances required for installing the Bluetooth® cradle are shown below. Avoid mounting the cradle on a plaster-board wall, but before mounting the cradle on a wall, fully check that the wall withstands the weight of the telephone and the load from pulling the telephone during operation.

### << Wall-mounting dimension diagram >>

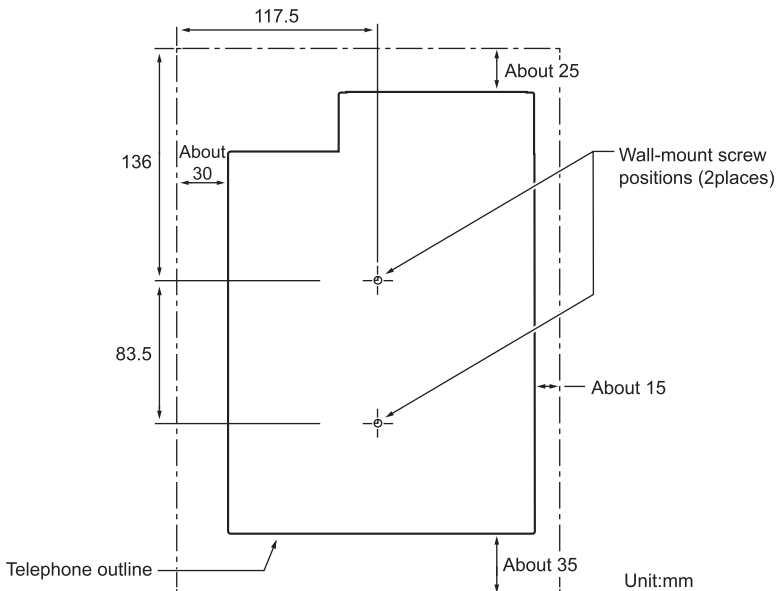

## ▼ Installation Procedure

Finish cabling to the Bluetooth® cradle before mounting it.

### 1 Attach two wood screws to the wall.

See “<< Wall-mounting dimension diagram >>” (P.1-35). Keep a clearance of about 2mm between each wood screw and the wall.

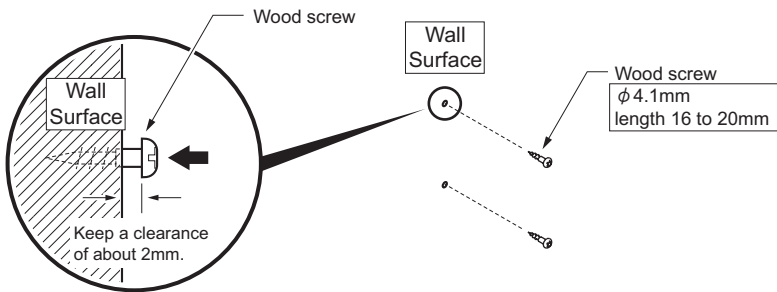

### 2 Remove the Bluetooth® handset hanger from the cradle.

Insert a rod in the hollow below and lift it up.

### 3 Insert the handset hanger in a different direction and slide it down to secure until it clicks into position.

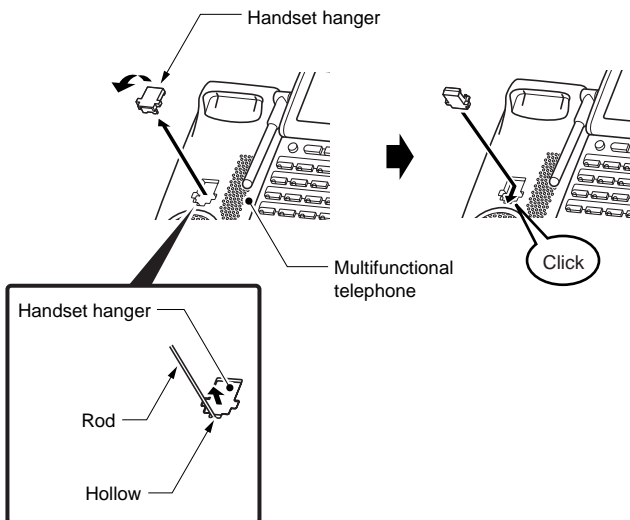

- 4 Turn over the telephone and lower the tilt legs to the first level.
- 5 Release lugs a and b on the stopper from grooves A and B in the tilt legs and widen the tilt legs.

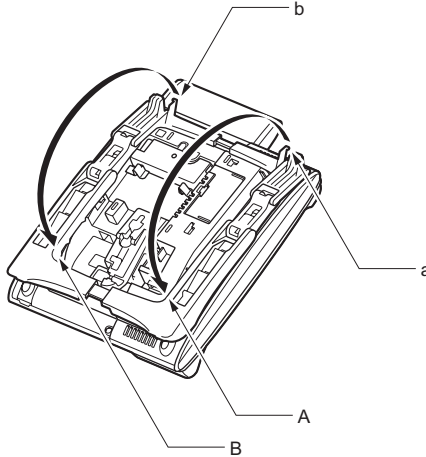

- 6 Hook wall-mount holes C and D on the back of the telephone on wood screws c and d attached in Step 1.

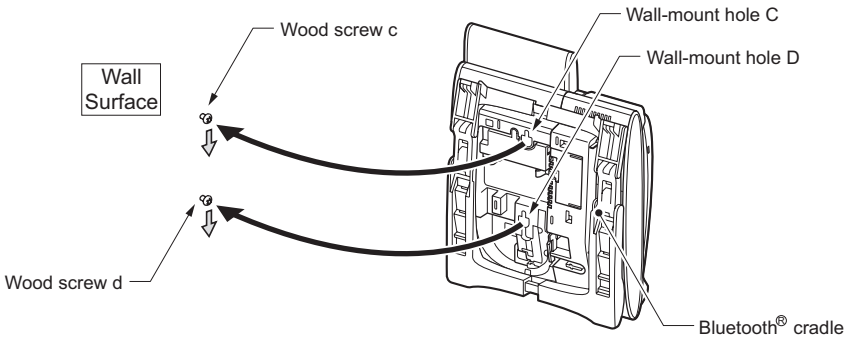

The installation of the Bluetooth® cradle is completed.



To return the Bluetooth® handset to a wall-mounted cradle, push it fully into position until its contacts touch the rear.

## Connecting a Headset

The following kinds of headsets can be used with a cordless terminal:

- Bluetooth® Cradle (BTC) side : Bluetooth® head set, wire head set
- Bluetooth® Handset (BTH) side : Wire head set

The method of connecting each headset is as follows.

### Pairing with a Bluetooth® Headset

A Bluetooth® headset can be connected to the Bluetooth® cradle (BTC) by pairing in a cradle menu operation. To perform pairing, follow these steps:

**1 Invoke the Bluetooth® device setup screen in the Bluetooth® cradle LCD screen.**

For instructions on how to invoke the setup screen, see “Configuring the Bluetooth® Cradle (BTC)” (P.1-25).

If the Bluetooth® headset has a PIN code of ‘0000’, go to Step 3; else, go to Step 2.

**2 In the Bluetooth® screen, select [1. Pairing Mode] > [2. PIN Code] in this order. Enter a PIN Code (4 to 16 digits) to suit the Bluetooth® device and press the OK key.**

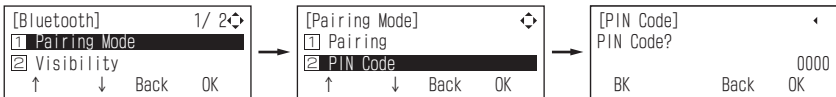



- 3** In the Bluetooth® screen, select [1. Pairing Mode] > [1. Pairing] > [1. -- Bluetooth Headset --] in this order and select a headset to pair with from a list of Bluetooth® devices located.

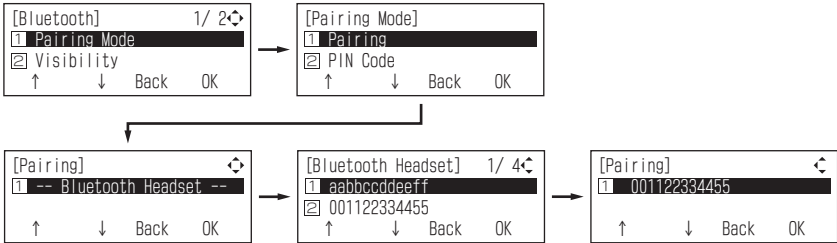

- 4** Select [1. Paired Head Set] > [2. Connect] > [2. Enable] in the pairing screen in this order and press the OK key.

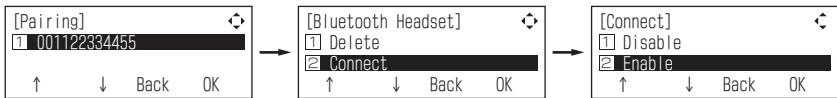

Pairing between the Bluetooth® headset and the Bluetooth® cradle (BTC) is completed.



After pairing, be sure to configure the cradle connection with the Bluetooth® headset in Step 4 to enable it. If connected setting is not done, the Bluetooth® headset that does the pairing cannot be used.



**To unpair a paired Bluetooth® headset**

Select [1. Delete] in the Bluetooth® Headset screen in Step 4 above to switch to a Delete screen. Press the OK key to unpair the paired Bluetooth® headset.

## ▼ Visibility Setting

Set whether to make information about the Bluetooth® cradle (BTC) visible to other Bluetooth® devices. The example below assumes that the cradle information is not made visible.

**1 Invoke the Bluetooth® device setup screen in the Bluetooth® cradle LCD screen.**

For instructions on how to invoke the setup screen, see “Configuring the Bluetooth® Cradle (BTC)” (P.1-25).

**2 In the Bluetooth® screen, select [2. Visibility] > [1. Disable] and press the OK key.**

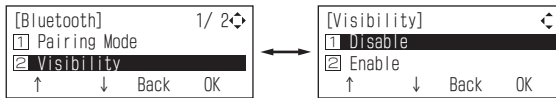

**The visibility setting is completed.**

## Connecting a Wire Headset

You can connect a headset to the Bluetooth® handset (BTH).

For latest recommended product information, browse the following Web site:

<http://www.necinfrontia.co.jp/>

Insert the headset plug firmly into the headset jack (bearing the  mark in the cover) on the right side of the Bluetooth® handset (BTH).

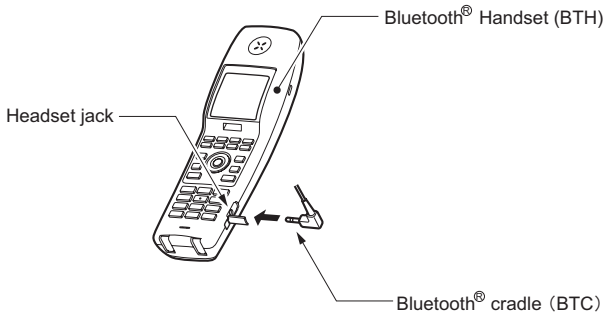



# Bluetooth® Handset Operations

Caution ..... 2-2

Bluetooth® Handset Functions ..... 2-3



## Caution

Take notice of these instructions when operating a cordless terminal:

- Cordless terminals take a certain length of time before they enable you to talk. Cordless terminals also take some time before switching a call originated by on-hook dialing to the Bluetooth® handset after you confirm the called party's response to it.
- The TALK lamp on the Bluetooth® handset may light green while it stands by off-hook after a dialing operation performed from the Bluetooth® cradle. Press the handset key to switch the call to the Bluetooth® handset.
- When making a phone call from the Bluetooth® handset after pressing the TALK or FNC/Conference key, make sure you hear a dial tone before pressing dial keys. Dial keys pressed before a dial tone is heard will be ignored.
- For operating instructions that use line keys, refer to the user documentation that comes with your system.

# Bluetooth® Handset Functions

## Key Lock

You can lock the Bluetooth® handset keys to disable them from being tampered.

### ▼ How To Enable the Key Lock

- 1** Press the Transfer key for 2 seconds.
- 2** A key lock icon appears in the LCD screen.

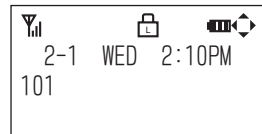

If a call terminates while the key lock is enabled

Press the TALK key, blinking line key or FNC/Conference key to answer the terminating call. While the call is in progress, the key lock is temporarily overridden to make all keys functional. Hang up to return to the key lock enabled state.

### ▼ How to disable

- 1** Press the Transfer key for 2 seconds.
- 2** The key lock icon disappears from the LCD screen.





# Troubleshooting

Troubleshooting Tips ..... 3-2



## Troubleshooting Tips

If you suspect a failure, try the actions recommended in the table below first. If the problem persists or the symptom you are experiencing is not listed here, call your dealer and request service.

Symptom	Point to check	Action
Shut down completely	<ul style="list-style-type: none"> <li>• Isn't the Bluetooth® cradle cord out of position?</li> <li>• Is the battery correctly loaded?</li> <li>• Is the battery charged?</li> <li>• Isn't the handset too remote from the Bluetooth® cradle? (Does the antenna mark in the Bluetooth® handset LCD screen show "Antenna" or isn't it off?)</li> </ul>	<ul style="list-style-type: none"> <li>• Inset the Bluetooth® cradle cord firmly into position.</li> <li>• Reload the battery correctly.</li> <li>• The battery may have been exhausted aged if the handset still fails when the battery is fully charged. Replace the battery.</li> <li>• Get closer to the Bluetooth® cradle to operate.</li> </ul>
Ring back tone does not sound	<ul style="list-style-type: none"> <li>• Isn't the ring tone volume turned OFF? (Doesn't the ring tone OFF appear in the Bluetooth® handset LCD screen?)</li> <li>• Is the battery correctly loaded?</li> </ul>	<ul style="list-style-type: none"> <li>• Adjust the ring tone volume.</li> <li>• Reload the battery correctly.</li> </ul>
Voice is disrupted while talking	<ul style="list-style-type: none"> <li>• Does the antenna mark in the handset LCD screen show "Antenna" or isn't it off?</li> <li>• Isn't there an obstacle, such as a concrete wall, between the Bluetooth® cradle and Bluetooth® handset?</li> </ul>	<ul style="list-style-type: none"> <li>• Get closer to the Bluetooth® cradle to operate.</li> <li>• Move to a location clear of intervening obstacles.</li> </ul>

Symptom	Point to check	Action
Noise heard while talking	<ul style="list-style-type: none"> <li>• Isn't there any home appliance or OA equipment nearby?</li> </ul>	<ul style="list-style-type: none"> <li>• Electrical equipment can be a source of radio interference. Keep apart from electrical equipment.</li> </ul>
Calls do not last long than 10 minutes even though the battery has been charged for 8 hours or longer	<ul style="list-style-type: none"> <li>• Is the Bluetooth® handset correctly seated in the Bluetooth® cradle?</li> <li>• Aren't the charging terminals soiled?</li> <li>• Hasn't the handset been used for nearly two years?</li> </ul>	<ul style="list-style-type: none"> <li>• Keep the Bluetooth® handset properly seated in the Bluetooth® cradle.</li> <li>• Wipe off dirt from the charging terminals of the Bluetooth® cradle and Bluetooth® handset with a dry cloth.</li> <li>• The battery may have been exhausted if two years have passed since the handset was first used. Replace the battery.</li> </ul>
Remote party's voice hard to hear	<ul style="list-style-type: none"> <li>• Isn't the Bluetooth® handset receiver volume set low?</li> </ul>	<ul style="list-style-type: none"> <li>• Press the up cursor key while talking to adjust the receiver volume.</li> </ul>
It sometimes happens that, when the TALK or FNC/Conference key is pressed, their respective lamps blink but do not stay continuously lit and the call is not established, with an error tone "pi-pi-pi-pi" sounding from the Bluetooth® handset.	<ul style="list-style-type: none"> <li>• Radio interference may be at fault.</li> <li>• Isn't there any source of radio interference nearby?</li> <li>• Is the cradle at least 3m apart from the equipment mentioned in "Locating the Bluetooth® Cradle" (P.1-14) ?</li> <li>• Isn't there any device near the Bluetooth® handset that is mentioned in "Locating the Bluetooth® Cradle" (P.1-14) ?</li> </ul>	<ul style="list-style-type: none"> <li>• Press the TALK or FNC/Conference key one again.</li> <li>• Keep the Bluetooth® cradle and Bluetooth® handset at least 3m apart from sources of possible radio interference.</li> </ul>



# Cordless Terminal User' s Guide

---

Store name



Please cooperate with recycling of a lithium ion battery.

Li-ion