

AirMagnet[®] A5205 Sensor

User Guide



© 2009 AirMagnet[®], Inc. All rights reserved.

AirMagnet[®] A5205 Sensor User Guide.

This *User Guide* is furnished under license and may be used or copied only in accordance with the terms specified in the license. The content of this document is furnished for informational purposes only and should not be construed as a commitment on the part of AirMagnet, Inc. AirMagnet, Inc. reserves the right to modify the content of this document without notice.

No part of this document may be reproduced, transmitted, stored in a retrieval system, or translated into any language in any form or by any means without the prior written consent of AirMagnet, Inc.

AIRMAGNET[®], INC. SHALL NOT BE HELD LIABLE FOR ERRORS, INACCURACIES, OR OMISSIONS THAT MAY EXIST IN THIS DOCUMENT; NOR FOR INCIDENTAL OR CONSEQUENTIAL DAMAGES RESULTING FROM THE USE OF THIS CONTENT.

AirMagnet[®] and AirWISE[®] are registered trademarks, and the AirMagnet logo is a trademark, of AirMagnet, Inc. All the other product names mentioned herein are trademarks or registered trademarks of their respective companies.

AirMagnet, Inc.
830 East Arques Ave.
Sunnyvale, CA 94085
USA

Compiled in the United States of America. January 15, 2009.

Documentation ID: 5205-v01-0001-USG-01-011509

Hardware Warranty

1. Products Warranty.

AirMagnet warrants that all Products (including associated firmware) sold by AirMagnet to Customer under the terms of this Agreement will be free from defects in workmanship and materials and shall fully comply with: (i) the Product Specifications as published under normal use and service, (ii) the End User documentation and (iii) all applicable United States laws, rules and regulations in effect at the time of Product shipment to Customer for a period of one (1) year after shipment to Customer. If any Product, or part thereof, contains a defect in materials or workmanship, or otherwise fails to conform to the Specifications, during the warranty period, AirMagnet shall, at its option and expense, correct any such defect by replacing, or repairing such defective Product.

2. Warranties Exclusive.

THE FOREGOING WARRANTIES, TERMS OR CONDITIONS ARE EXCLUSIVE AND ARE IN LIEU OF ALL OTHER WARRANTIES, TERMS OR CONDITIONS, EXPRESS OR IMPLIED, EITHER IN FACT OR BY OPERATION OF LAW, STATUTORY OR OTHERWISE, INCLUDING WARRANTIES, TERMS OR CONDITIONS OF MERCHANTABILITY, NON-INFRINGEMENT OF THIRD PARTY RIGHTS, AND FITNESS FOR A PARTICULAR PURPOSE.

3. Warranty Exclusions.

AIRMAGNET SHALL NOT BE LIABLE UNDER THIS WARRANTY IF ITS TESTING AND EXAMINATION DISCLOSES THAT THE ALLEGED DEFECT IN THE PRODUCT DOES NOT EXIST OR WAS CAUSED BY CUSTOMER'S OR ITS END USER'S MISUSE, NEGLIGENCE, IMPROPER INSTALLATION OR TESTING, UNAUTHORIZED ATTEMPTS TO REPAIR, OR BY ACCIDENT, FIRE, LIGHTNING OR OTHER HAZARD. AIRMAGNET DOES NOT WARRANT THE ACCURACY OR COMPLETENESS OF THE INFORMATION, TEXT, GRAPHICS, LINKS OR OTHER ITEMS TRANSMITTED BY THE PRODUCTS.

4. Product Repairs.

AirMagnet will Repair a defective Product and forward the same back to Customer. AirMagnet will upgrade Repaired Product to the most recent engineering change level. Any Repaired Product shall be warranted for three (3) months or the remainder of the initial warranty period, whichever is longer. This statement excludes Products that has been damaged by accident, abuse or misuse. AirMagnet's obligation to Repair defective Products under this section is subject to Customer's strict adherence to the RMA procedures set forth in Section 5.

5. Return Material Authorization (RMA).

AirMagnet shall provide Customer with RMA procedures. The following procedure shall apply to AirMagnet's Repair of Products.

(i) Management.

AirMagnet will use its best efforts to provide Customer with an RMA number within three (3) business days after receipt of request. Customer will ship RMA returns to AirMagnet with enough information to allow AirMagnet to reproduce the problem promptly.

(ii) Turn-Around Time.

AirMagnet will Repair any defective Product within which it can reproduce the problem and forward the same back to Customer within five (5) business days after receipt. At Customer's option, AirMagnet will provide advanced replacement unit as in AirMagnet's published price list.

(iii) Shipping Charges.

During the warranty period, Customer will pay transportation charges and assume risk of loss for Products shipped to AirMagnet for Repair. AirMagnet will pay transportation charges by UPS ground or FedEx ground service and assume risk of loss for all Products returned to Customer during the warranty period. Customer can request and pay for expedited service by providing Customer's own UPS or FedEx number, or by credit card prepayment. After warranty expires, Customer shall pay all (round trip) shipping charges.

(iv) Packaging requirements.

On all Products returned to Customer, AirMagnet will affix label that identifies Product, including model number, serial number, current revision level, and RMA number.

6. Pricing and Out-of-Warranty Repairs.

There is no charge for in-warranty Repairs, except as provided in Section 3. For each Product purchased under this Agreement, AirMagnet agrees to make out of warranty repair services available to Customer for a period of three (3) years after the expiration of the one (1) year warranty period for such Product. Charges for out of warranty repair services, upgrade kits, and spare parts will be at AirMagnet's published price list.

Table of Contents

Hardware Warranty	i
1. Products Warranty.	i
2. Warranties Exclusive.	i
3. Warranty Exclusions.....	i
4. Product Repairs.....	ii
5. Return Material Authorization (RMA).....	ii
(i) Management.....	ii
(ii) Turn-Around Time.....	ii
(iii) Shipping Charges.....	ii
(iv) Packaging requirements.....	iii
6. Pricing and Out-of-Warranty Repairs.....	iii
Chapter 1: Introduction	1
Product Overview	1
Checking Product Package Content	1
A5231 Sensor Mounting Bracket Kit	1
Getting Technical Support.....	2
Product Documentation	3
Chapter 2: Getting Started	5
A5205 Sensor Exterior Views	5
A5205 Sensor LEDs	6
A5205 Sensor Rear Panel Interfaces	7
A5205 Bottom Cover.....	9
Applying Tamper-Evident Seals	9
Chapter 3: Installing A5205 Sensor	13
A5205 Sensor Zero Configuration	13
Installing the A5205 Sensor	13

Installing the A5205 Sensor on a Counter Top.....	13
Mounting the A5205 Sensor on a Wall	14
Installing A5205 Sensor on a T-Rail	14
Installing A5205 Sensor with A5031 Mounting Bracket .	15
Powering Up A5205 Sensors	17
Powering Up via an 802.3af-Compliant PoE Injector	17
Powering Up Directly via an 802.3af-Compliant Switch .	18
Appendix A: A5205 Sensor Specifications.....	19
Index.....	23

Chapter 1: Introduction

Product Overview

Thank you for choosing AirMagnet A5205 Sensor!

AirMagnet A5205 Sensor is a new generation of the AirMagnet SmartEdge Sensor family. It features the new Intel xScale 425 533-MHz processor, a standard 10/100 MB Ethernet Base-T port with IEEE 802.3af Power over Ethernet (PoE) compliance, four 2.4-GHz/5-GHz dual-band internal antennas, and zero configuration. Using the latest 802.11n wireless technology, the new sensor platform offers great network coverage, speed, reliability, and security. It also offers unprecedented ease in deployment and maintenance.

For detailed product specifications, see “Appendix A: A5205 Sensor Specifications”.

Checking Product Package Content

A complete AirMagnet A5205 Sensor product package contains the following items:

- One (1) printed AirMagnet A5205 Sensor Information Sheet
- One (1) AirMagnet A5205 Sensor
- One (1) DB9 female/female serial cross-over console cable

In case any of these items is missing or damaged, contact your AirMagnet product reseller or AirMagnet technical support immediately.

A5231 Sensor Mounting Bracket Kit

The A5231 Sensor Mounting Bracket Kit is needed for mounting the A5205 Sensor on the wall or a T-rail. The kit is optional and can be purchased separately from AirMagnet.

The whole Mounting Kit contains the following items:

- One (1) AirMagnet A5231 Mounting Bracket
- Four (4) #8x $\frac{3}{4}$ in. screws
- Four (4) plastic anchors, and
- Four (4) spacers

The new A5205 Sensor is also backward compatible with the A5031 Mounting Bracket which provides extra security for the Sensor. See “Installing A5205 Sensor with A5031 Mounting Bracket” on page 15. Contact AirMagnet Sales department for more information.

Getting Technical Support

AirMagnet A5205 Sensor is a plug-and-play WLAN appliance that requires no configuration. Once it is connected to a WLAN, it will be able to automatically find and communicate with the AirMagnet Enterprise Server provided that the server is already installed on the network. If you encounter any problem when installing and/or using the A5205 Sensor, you may contact us for technical support using the following:

Table 1-1: AirMagnet Technical Support Contact Information

Way of Contact	Contact Information
Phone:	(877) MAGNET5 (624-6385) (Toll-free); or (408) 400-0200 (Option 3)
Fax:	(408) 744-1250
E-mail:	support@airmagnet.com
Website:	http://www.airmagnet.com

Table 1-1: AirMagnet Technical Support Contact Information

Way of Contact	Contact Information
Mail:	AirMagnet, Inc. 830 East Arques Ave. Sunnyvale, CA 94085 USA

Product Documentation

This *User Guide* covers the key features of AirMagnet A5205 Sensor and its installation procedures. It reflects the status of the product at the time of its release. Any question that may arise thereafter related to the use of the A5205 Sensor will be addressed in the FAQ section on our website. Customers are encouraged to use those FAQs before contacting us for technical support. The FAQs can be accessed at <http://www.airmagnet.com/faq>.

Chapter 2: Getting Started

A5205 Sensor Exterior Views

This chapter discusses the physical features of the A5205 Sensor. Figures 2-1 and 2-2 illustrate the exterior of A5205 Sensor from different perspectives.



Figure 2-1: A5205 Sensor Front/Top View



Figure 2-2: A5205 Sensor Back/Top View

A5205 Sensor LEDs

The front panel of the A5205, as shown in Figure 2-1, has three LEDs which reflect the working condition of the A5205 Sensor. Figure 2-3 is a close-up view of the LEDs on A5205 Sensor's front panel, and Table 2-1 briefly describes each of the LEDs.

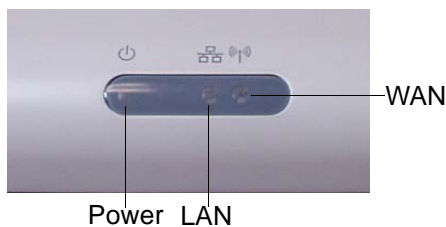

Figure 2-3: A5205 Sensor LEDs

Table 2-1: A5205 Sensor LEDs

LED	Color	Status	Description
Power	Green	Steady	The Sensor is powered up and ready.
	Green	Flickering	The Sensor is not ready, e.g., configuration in progress.
		Off	The Sensor is powered off.
LAN	Green	Flickering	The Sensor is powered up and working properly.
		Off	The Sensor is powered off or its LAN port is experiencing a connection problem.
WLAN	Green	On	The Sensor is in <i>Monitor Mode</i> , i.e., receiving packets.
	Amber	On	The Sensor is in <i>Client Mode</i> , i.e., sending packets.
		Off	The Sensor is powered off.

A5205 Sensor Rear Panel Interfaces

Figure 2-4 shows A5205 Sensor's rear panel which contains the device's various interfaces. Table 2-2 provides a brief description of each of the interfaces.



Figure 2-4: A5205 Sensor Rear Panel

Table 2-2: A5205 Sensor Real Panel Interfaces

Interface	Description
Power 12V	For supplying power to the Sensor using a DC 12V universal adapter. Note: This does not apply when PoE is used.
Reset	<ul style="list-style-type: none"> Pressing and holding down the button for less than 5 seconds will reboot the Sensor. Pressing and holding down the button for more than 5 seconds will reset the Sensor to its factory default settings.
RJ-45	(Lan Port) For connecting the Sensor to an Ethernet network through an RJ-45 Ethernet cable. The RJ-45 comes with built-in 802.3af PoE compliance.
RS-232	(Serial Port) For troubleshooting the Sensor using the Hyperterminal.

A5205 Bottom Cover

Figure 2-6 shows the bottom cover of the A5205 Sensor. The A5205 Sensor comes with four removable rubber pads on its bottom cover (shown in the picture below). They help prevent the Sensor from skidding when deployed on a flat surface, without using the A5231 Mounting Bracket. However, these rubber pads must be removed when mounting the Sensor onto the Mounting Bracket. See “Chapter 3: A5205 Sensor Installation” for more information.



Figure 2-5: A5205 Sensor Bottom Cover

Applying Tamper-Evident Seals

The tamper-evident seals are intended to prevent tampering of the AirMagnet SmartEdge Sensors and help network administrators to easily identify traces of tampering should it have occurred. To effectively use the tamper-evident seals, care must be taken to ensure that the seals are applied properly.

The tamper-evident seals are required for AirMagnet Sensors operated in FIPS mode. The following instructions apply only to Sensors that are intended to comply with the FIPS requirement.

To apply the tamper-evident seals:

- 1) Tighten each of the retention screws using a screwdriver, making sure that they are all tight.
- 2) Clean the areas where the seals are to be applied.
- 3) Place the seals over the sides of A5205 Sensor, as shown in Figure 2-7.

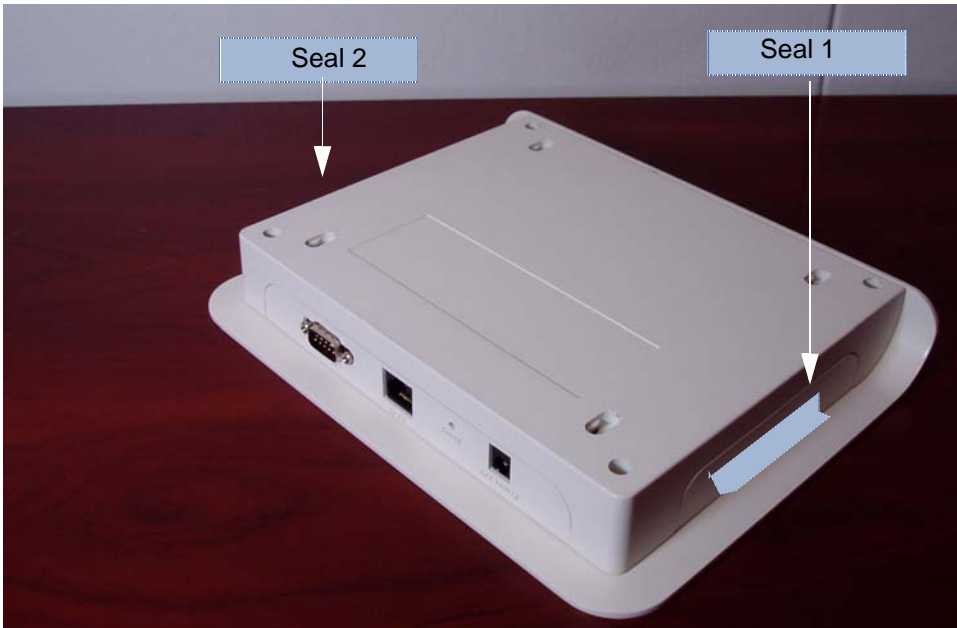

Figure 2-6: Applying tamper-evident seals

Important Make sure that the seals are applied approximately evenly (50%-50%) to the bottom and the cover of the module, as only one part of the seal needs to be removed to defeat the seal.

- 4) Firmly press the seal ends to cover the seam between the bottom and the cover of the module.
-

Important Firmly press the entire seal surface onto the module surface to ensure the best adhesion possible.

- 5) Record the seal serial numbers and confirm their presence in later module inspections.
- 6) Allow 24 hours for the seal adhesive to dry completely.

Chapter 3: Installing A5205 Sensor

A5205 Sensor Zero Configuration

The A5205 Sensor comes with a zero configuration feature that enables users to take an unconfigured Sensor and place it on their network and have it automatically find and connect to the AirMagnet Enterprise Server without having to configure the Sensor first. This concept alleviates the cumbersome steps of configuring and managing Sensors during deployment. It also reduces the overhead during regular maintenance cycles.

To take advantage of the Sensor zero configuration feature, the user must enable the zero configuration feature on the AirMagnet Enterprise Server. This feature also carries over to the Sensor properties screen on the AirMagnet Enterprise Console. The user can change the Sensor's shared secret key from the Console and have it automatically forwarded to the Sensor.

For more information on Sensor zero configuration, see *AirMagnet Enterprise User Guide*.

Installing the A5205 Sensor

For better performance, the A5205 Sensor should be installed where maximum field of view (FOV) can be achieved. This means that it should be deployed in places where it can cover as large an area as possible with little or no obstruction. The instructions below show how to install the sensor using the mounting bracket.

Installing the A5205 Sensor on a Counter Top

The A5205 Sensor comes with four rubber pads on its back. The pads provide traction that help prevent the Sensor from skidding when it is placed on a flat (horizontal) surface, such as a counter top.

To install the A5205 Sensor on counter top:

- 1) Place the A5205 Sensor on a desired counter top, making sure that the four rubber pads stay on the bottom of the Sensor for traction.
- 2) Connect the Sensor to the LAN using an RJ-45 cable.
- 3) Connect the Sensor to the power source, unless PoE is used.

Mounting the A5205 Sensor on a Wall

The A5205 Sensor can be mounted on any vertical surface, such as a wall, using the AirMagnet A5231 Sensor Mounting Bracket.

The A5231 Sensor Mounting Bracket is sold separately. To order, contact your AirMagnet reseller or AirMagnet sales.

- 1) Select an ideal location on a wall with good FOV.
- 2) Install the A5231 Mounting Bracket, with the four metal feet facing away from the wall.
- 3) Remove the four rubber pads from the back of the A5205 Sensor.
- 4) Align the four holes in the back of the Sensor with the metal feet on the Mounting Bracket.
- 5) Press the Sensor down slightly to make sure that the metal feet are fully engaged with the body of the Sensor.
- 6) Slide the Sensor gently downward until the tab of the Mounting Bracket clicks onto the Sensor.

Installing A5205 Sensor on a T-Rail

The ceiling of a building is an ideal place for installing the Sensor in terms of FOV. With the A5231 Mounting Bracket, you can place the Sensor anywhere on a T-rail on the ceiling.

To install the Sensor on a T-rail:

- 1) Slide the Sensor onto the Mounting Bracket, making sure that the Sensor and the Mounting Bracket are fully engaged.
- 2) Install the A5231 Mounting Bracket on a T-rail.

- 3) Connect the Sensor to your LAN with an RJ-45 cable.
- 4) Connect the sensor to the power source.

See the A5231 Mounting Bracket Installation Guide for detailed instructions on how to use the A5231 Mounting Bracket.

Installing A5205 Sensor with A5031 Mounting Bracket

The A5205 Sensor is backward-compatible with the A5031 Sensor Mounting Bracket, which not only gives users the same flexibility to mount the Sensor anywhere they desire, but also offers an additional security feature that helps prevent the Sensor from tampering and theft.

To install your A5205 Sensor Using an A5031 Mounting Bracket:

- 1) Install the A5031 Mounting Bracket where the Sensor is to be deployed.

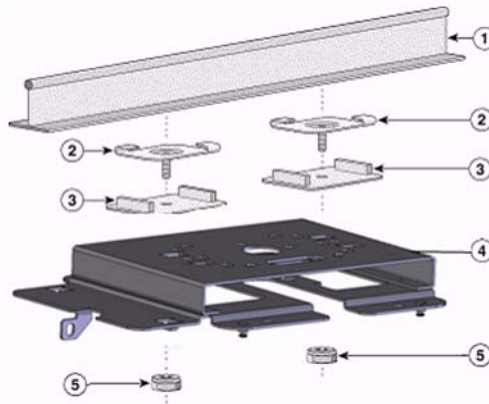

Figure 3-1: Assembling the A5031 Mounting Bracket

- 2) Remove the rubber pads from the A5205 Sensor's bottom cover.
- 3) Mount the Sensor onto the A5031 Mounting Bracket.

Make sure that the four metal knobs on each corner of the A5031 Mounting Bracket are aligned with and set inside the holes on the four corners of the A5205 Sensor's bottom cover.

- 4) Gently slide the Sensor towards the Locking Plate until it is fully engaged.
- 5) Secure the Sensor with padlock.

Powering Up A5205 Sensors

Customers deploying AirMagnet Enterprise can power their AirMagnet sensors using a standard Ethernet cable, thus avoiding the need to run the standard electrical wiring to each and every individual sensor. AirMagnet offers two PoE options, and customers can typically make their own choice based on the quality of the switch to which their AirMagnet sensors will be connected.

Powering Up via an 802.3af-Compliant PoE Injector

To power up A5205 Sensor via an 802.3af-compliant PoE Injector:

- 1) Connect the PoE injector (via the Data Only port) to a network switch or hub, using a 10/100 Ethernet cable.
- 2) Connect the PoE injector (via the Power and Data port) to A5205 Sensor using another 10/100 Ethernet cable.
- 3) Plug the power cord into an electrical outlet. See Figure 3-2.

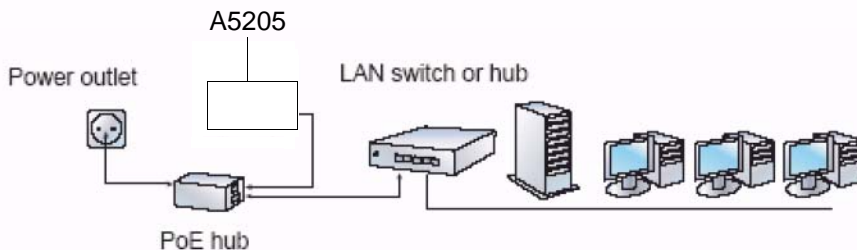

Figure 3-2: Powering up A5205 via 802.3af-compliant

Powering Up Directly via an 802.3af-Compliant Switch

To power up A5205 Sensor directly via an 802.3af-compliant switch:

- 1) Connect the A5205 Sensor to an IEEE 802.3af-compliant network switch (e.g, a Cisco Catalyst 3560 Series PoE-24) using a 10/100 Ethernet cable. See Figure 3-3.

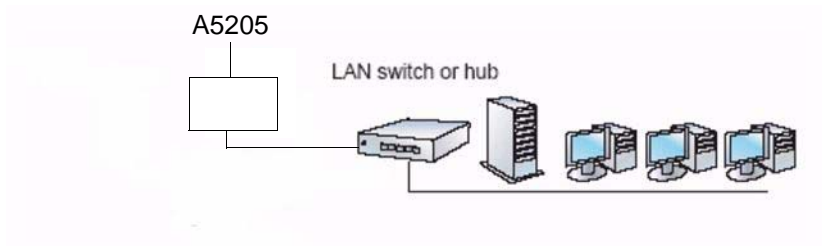

Figure 3-3: Powering up A5205 via an 802.3af-compliant switch

Appendix A: A5205 Sensor Specifications

This section contains detailed product specifications of the AirMagnet 802.11n A5205 Internal Antenna Sensor.

Feature	Description
Mechanical	<ul style="list-style-type: none"> Material meeting UL 2043 Safety and flammability standards Removable antennas Seismic vibration PCB/Daughter-card/antenna connector resiliency Mounting bracket (chassis to accommodate both wall mounting and ceiling placement)
Environmental	<ul style="list-style-type: none"> Temperature: 32° F~131° F (0° C~ 55° C) Humidity: 10%~90% (non-condensing) (DC power adapter exclude)
Processor	<ul style="list-style-type: none"> Intel IXP 425 533 MHz; clock speed
System Memory	<ul style="list-style-type: none"> 64 MB SDRAM min., PCB with option for adding up to 128 MB 16 MB Flash ROM
WiFi Silicon	<ul style="list-style-type: none"> Mini-PCI dual-band 802.11a/b/g/n, with Atheros chipset MB82 (AR9160+9106)
Operating Voltage	<ul style="list-style-type: none"> 12V DC +/- 5%; 48V +/- 10% (802.3af PoE)
Current Consumption	<ul style="list-style-type: none"> Typical 600 mA (12V DC); 180 mA (48V PoE)
Input Power Requirement	<ul style="list-style-type: none"> PoE 802.3af compliant

Status LEDs	<ul style="list-style-type: none"> • Power • WLAN (2.4 GHz/5GHz) • LAN 10/100 Base-T
LAN Port	<ul style="list-style-type: none"> • RJ-45 with built-in 802.3af PoE compliance
Serial Port	<ul style="list-style-type: none"> • External connector required, DB-9 male, RS-232 null modem
External Switch	<ul style="list-style-type: none"> • Reset switch
DC Input Connector	<ul style="list-style-type: none"> • DC power input jack
RF Connectors	<ul style="list-style-type: none"> • N/A; Internal antennas with ufl connectors
Standard Antennas (Dual-band 2.4/5 GHz)	<ul style="list-style-type: none"> • Default (3) internal PCB dual-band antennas
Data Rates	<ul style="list-style-type: none"> • 802.11a: 6, 9, 12, 18, 24, 36, 48, 54, and 108 Mbps turbo mode • 802.11g: 6, 9, 12, 18, 24, 36, 48, and 54 Mbps • 802.11b: 1, 2, 5.5, and 11 Mbps • 802.11n: @ 800 GI (400 GI) 20 MHz BW 1 Nss: 65 (72.2) Mbps maximum 2 Nss: 130 (144.444) Mbps maximum 40 MHz BW 1 Nss: 135 (150) Mbps maximum 2 Nss: 270 (300) Mbps maximum

Frequency Bands (For operating in the US, the frequency is fixed; users cannot select other bands)	<ul style="list-style-type: none"> • 802.11a: 5.15~5.25 GHz; 5.25~5.35 GHz; 5.725~5.825 GHz • 802.11b/g: 2.412~2.462 GHz (US) 2.412~2.272 GHz (Europe ETSI) 2.412~2.484 GHz (Japan) 2.457~2.462 GHz (Spain) 2.457~2.472 GHz (France) • 802.11n: dual band, same as 802.11a and 802.11b/g (see above)
Receive Sensitivity (Typical)	<ul style="list-style-type: none"> • 802.11a: -84 dBm @ 6 Mbps -82 dBm @ 9 Mbps -79 dBm @ 12 Mbps -77 dBm @ 18 Mbps -75 dBm @ 24 Mbps -73 dBm @ 36 Mbps -70 dBm @ 48 Mbps -68 dBm @ 54 Mbps • 802.11b/g: -91 dBm @ 1 Mbps -90 dBm @ 2 Mbps -89 dBm @ 5.5 Mbps -87 dBm @ 11 Mbps -84 dBm @ 6 Mbps -82 dBm @ 9 Mbps -79 dBm @ 12 Mbps -77 dBm @ 18 Mbps -75 dBm @ 24 Mbps -73 dBm @ 36 Mbps -70 dBm @ 48 Mbps -68 dBm @ 54 Mbps • 802.11n (5 GHz Band): -63 dBm @ 130 Mbps -61 dBm @ 270 Mbps • 802.11n (2.4 GHz Band): -63 dBm @ 130 Mbps -61 dBm @ 270 Mbps

Transmit Output Power (Typical)	<ul style="list-style-type: none">• 802.11a: 13~15 dBm @ 6~24 Mbps 16 dBm +/-2 @ 36 Mbps 15 dBm +/-2 @ 48 Mbps 13 dBm +/-2 @ 54 Mbps 13 dBm +/-2 @ 108 Mbps• 802.11b: 13~16 dBm for all rates• 802.11g: 10~13 dBm @ 6~24 Mbps 10~13 dBm @ 36 Mbps 10~13 dBm @ 48 Mbps 15 dBm +/-2 @ 54 Mbps• 802.11n: 5 GHz Band 13~15 dBm @ 130 Mbps 13~15 dBm @ 270 Mbps 2.4 GHz Band 9~11 dBm @ 130 Mbps 9~11 dBm @ 270 Mbps
--	--

Compliance

Index

Numerics

- 10/100 Ethernet cable 14
- 2.4-GHz 1
- 2.4-GHz RF Connector 8
- 5-GHz 1
- 5-GHz RF Connector 8
- 802.3af-compliant PoE Injector 13
- 802.3af-Compliant Power Device 13
- 802.3af-Compliant Switch 14
- 802.3af-compliant switch 13

A

- A5031 Mounting Bracket 1
- A5031 Mounting Kit 1
- antennas 1
- appliance 2

B

- bottom cover 9

C

- Compliance 18
- configuration 2
- Connector 19, 20
- contact 2

D

- deployment 11
- Dimensions 20, 21
- dual-band 1, 8

E

- EEPROM 15
- electrical outlet 13
- electrical wiring 13
- Enterprise Console 11
- Enterprise Server 2, 11
- Environmental 15
- Ethernet Base-T port 1
- Ethernet cable 13
- exterior 5

F

- FAQ 2
- field of view 11
- Frequency Bands 16
- front panel 6

H

- high-gain 19
- high-gain antennas 8
- high-gain dual-band antenna 19, 20
- HPBW/Horizontal 19, 20
- HPBW/Vertical 19, 20
- hub 13
- Humidity 20, 21

I

- Impedance 19, 20
- Information Sheet 1
- install 11

installation procedures 2
Intel 1
interfaces 7

K

key features 2

L

LAN 6
LAN Port 8, 16
LEDs 6
Locking Plate 1, 13

M

maintenance 11
Mechanical 15
Mounting Bracket 9

N

network 13

O

Out-of-Warranty Repairs iii

P

physical features 5
plug-and-play 2
PoE 13
PoE injector 13
Polarization 19, 20
Power 6, 8
power 13
Power handling 19
processing speed 1
Processor 15
product package 1
Product Registration 5

Product Repairs ii
Products Warranty i

R

Radome color 20, 21
Radome material 20, 21
rear panel 7
Reboot/Reset Button 8
removable 1
reseller 2
Return Material Authorization ii
RF 15
RMA ii
rubber pads 9, 12

S

Serial Port 8, 16
shared secret key 11
single-band 8
skidding 9
SmartEdge Sensor 1
specifications 15
standard 1, 8
switch 13
System Memory 15

T

Tamper-Evident Seals 9
technical support 2, 3
Temperature 20, 21

U

unconfigured 11

V

VSWR 19, 20

W

Warranties Exclusive i

Warranty Exclusions i

Watchdog 16

Website 3

Weight 20, 21

Wi-Fi Silicon 15

WLAN 6

X

xScale 1

Z

zero configuration 1, 11

Federal Communication Commission Interference Statement

This equipment has been tested and found to comply with the limits for a Class B digital device, pursuant to Part 15 of the FCC Rules. These limits are designed to provide reasonable protection against harmful interference in a residential installation. This equipment generates, uses and can radiate radio frequency energy and, if not installed and used in accordance with the instructions, may cause harmful interference to radio communications. However, there is no guarantee that interference will not occur in a particular installation. If this equipment does cause harmful interference to radio or television reception, which can be determined by turning the equipment off and on, the user is encouraged to try to correct the interference by one of the following measures:

- Reorient or relocate the receiving antenna.
- Increase the separation between the equipment and receiver.
- Connect the equipment into an outlet on a circuit different from that to which the receiver is connected.
- Consult the dealer or an experienced radio/TV technician for help.

FCC Caution: Any changes or modifications not expressly approved by the party responsible for compliance could void the user's authority to operate this equipment.

For operation within 5.15 ~ 5.25GHz frequency range, it is restricted to indoor environment.

This device complies with Part 15 of the FCC Rules. Operation is subject to the following two conditions: (1) This device may not cause harmful interference, and (2) this device must accept any interference received, including interference that may cause undesired operation.

IMPORTANT NOTE:

Radiation Exposure Statement:

This equipment complies with FCC radiation exposure limits set forth for an uncontrolled environment. This equipment should be installed and operated with minimum distance 20cm between the radiator & your body.

This transmitter must not be co-located or operating in conjunction with any other antenna or transmitter.

The availability of some specific channels and/or operational frequency bands are country dependent and are firmware programmed at the factory to match the intended destination. The firmware setting is not accessible by the end user.

A5200 / A5205 with Embedded type antenna and max. antenna gain is **5.1dBi** in 5G and **2.8dBi** in 2.4G.

Industry Canada statement

This device complies with RSS-210 of the Industry Canada Rules. Operation is subject to the following two conditions: (1) This device may not cause harmful interference, and (2) this device must accept any interference received, including interference that may cause undesired operation.

IMPORTANT NOTE:

IC Radiation Exposure Statement:

This equipment complies with IC radiation exposure limits set forth for an uncontrolled environment. This equipment should be installed and operated with minimum distance 20cm between the radiator and your body.

Industry Canada Interference Statement

The device for the band 5150-5250 MHz is only for indoor usage to reduce potential for harmful interference to co-channel mobile satellite systems;

The maximum antenna gain **5.1dBi** permitted (for devices in the bands 5250-5350 MHz and 5470-5725 MHz) to comply with the e.i.r.p. limit; and

The maximum antenna gain **4.5dBi** permitted (for devices in the band 5725-5825 MHz) to comply with the e.i.r.p. limits specified for point-to-point and non point-to-point operation as appropriate, as stated in section A9.2(3).

In addition, users should also be cautioned to take note that high-power radars are allocated as primary users (meaning they have priority) of the bands 5250-5350 MHz and 5650-5850 MHz and these radars could cause interference and/or damage to LE-LAN devices.

Europe – EU Declaration of Conformity

This device complies with the essential requirements of the R&TTE Directive 1999/5/EC. The following test methods have been applied in order to prove presumption of conformity with the essential requirements of the R&TTE Directive 1999/5/EC:















- **EN60950-1: (2006)**
Safety of Information Technology Equipment
- **EN50385 : (2002-08)**
Product standard to demonstrate the compliance of radio base stations and fixed terminal stations for wireless telecommunication systems with the basic restrictions or the reference levels related to human exposure to radio frequency electromagnetic fields (110MHz - 40 GHz) - General public
- **EN 300 328 V1.7.1: (2006-10)**
Electromagnetic compatibility and Radio spectrum Matters (ERM); Wideband Transmission systems; Data transmission equipment operating in the 2,4 GHz ISM band and using spread spectrum modulation techniques; Harmonized EN covering essential requirements under article 3.2 of the R&TTE Directive
- **EN 301 893 V1.4.1: (2007-07)**
Broadband Radio Access Networks (BRAN);5 GHz high performance RLAN; Harmonized EN covering essential requirements of article 3.2 of the R&TTE Directive
- **EN 301 489-1 V1.8.1: (2008-04)**
Electromagnetic compatibility and Radio Spectrum Matters (ERM); ElectroMagnetic Compatibility (EMC) standard for radio equipment and services; Part 1: Common technical requirements
- **EN 301 489-17 V1.3.2 (2008-04)**
Electromagnetic compatibility and Radio spectrum Matters (ERM); ElectroMagnetic Compatibility (EMC) standard for radio equipment; Part 17: Specific conditions for 2,4 GHz wideband transmission systems, 5 GHz high performance RLAN equipment and 5,8 GHz Broadband Data Transmitting Systems
-



This device is a 2.4 GHz wideband transmission system (transceiver), intended for use in all EU member states and EFTA countries, except in France and Italy where restrictive use applies.

In Italy the end-user should apply for a license at the national spectrum authorities in order to obtain authorization to use the device for setting up outdoor radio links and/or for supplying public access to telecommunications and/or network services.

This device may not be used for setting up outdoor radio links in France and in some areas the RF output power may be limited to 10 mW EIRP in the frequency range of 2454 – 2483.5 MHz. For detailed information the end-user should contact the national spectrum authority in France.

CE 0560 

 Český [Czech]	<i>[Jméno výrobce]</i> tímto prohlašuje, že tento <i>[typ zařízení]</i> je ve shodě se základními požadavky a dalšími příslušnými ustanoveními směrnice 1999/5/ES.
 Dansk [Danish]	Undertegnede <i>[fabrikantens navn]</i> erklærer herved, at følgende udstyr <i>[udstyrets typebetegnelse]</i> overholder de væsentlige krav og øvrige relevante krav i direktiv 1999/5/EF.
 Deutsch [German]	Hiermit erkläre <i>[Name des Herstellers]</i> , dass sich das Gerät <i>[Gerätetyp]</i> in Übereinstimmung mit den grundlegenden Anforderungen und den übrigen einschlägigen Bestimmungen der Richtlinie 1999/5/EG befindet.
 Eesti [Estonian]	Käesolevaga kinnitab <i>[tootja nimi = name of manufacturer]</i> seadme <i>[seadme tüüp = type of equipment]</i> vastavust direktiivi 1999/5/EÜ põhinõuetele ja nimetatud direktiivist tulenevatele teistele asjakohastele sätetele.
 English	Hereby, <i>[name of manufacturer]</i> , declares that this <i>[type of equipment]</i> is in compliance with the essential requirements and other relevant provisions of Directive 1999/5/EC.
 Español [Spanish]	Por medio de la presente <i>[nombre del fabricante]</i> declara que el <i>[clase de equipo]</i> cumple con los requisitos esenciales y cualesquiera otras disposiciones aplicables o exigibles de la Directiva 1999/5/CE.
 Ελληνική [Greek]	ΜΕ ΤΗΝ ΠΑΡΟΥΣΑ <i>[name of manufacturer]</i> ΔΗΛΩΝΕΙ ΟΤΙ <i>[type of equipment]</i> ΣΥΜΜΟΡΦΩΝΕΤΑΙ ΠΡΟΣ ΤΙΣ ΟΥΣΙΩΔΕΙΣ ΑΠΑΙΤΗΣΕΙΣ ΚΑΙ ΤΙΣ ΛΟΙΠΕΣ ΣΧΕΤΙΚΕΣ ΔΙΑΤΑΞΕΙΣ ΤΗΣ ΟΔΗΓΙΑΣ 1999/5/EK.
 Français [French]	Par la présente <i>[nom du fabricant]</i> déclare que l'appareil <i>[type d'appareil]</i> est conforme aux exigences essentielles et aux autres dispositions pertinentes de la directive 1999/5/CE.
 Italiano [Italian]	Con la presente <i>[nome del costruttore]</i> dichiara che questo <i>[tipo di apparecchio]</i> è conforme ai requisiti essenziali ed alle altre disposizioni pertinenti stabilite dalla direttiva 1999/5/CE.
Latviski [Latvian]	Ar šo <i>[name of manufacturer / izgatavotāja nosaukums]</i> deklarē, ka <i>[type of equipment / iekārtas tips]</i> atbilst Direktīvas 1999/5/EK būtiskajām prasībām un citiem ar to saistītajiem noteikumiem.
Lietuvių [Lithuanian]	Šiuo <i>[manufacturer name]</i> deklaruojama, kad šis <i>[equipment type]</i> atitinka esminius reikalavimus ir kitas 1999/5/EB Direktyvos nuostatas.
 Nederlands [Dutch]	Hierbij verklaart <i>[naam van de fabrikant]</i> dat het toestel <i>[type van toestel]</i> in overeenstemming is met de essentiële eisen en de andere relevante bepalingen van richtlijn 1999/5/EG.
 Malti [Maltese]	Hawnhekk, <i>[isem tal-manifattur]</i> , jiddikjara li dan <i>[il-mudel tal-prodott]</i> jikkonforma mal- ħtiġijiet essenzjali u ma provvedimenti oħrajn relevanti li hemm fid-Dirrettiva 1999/5/EC.
 Magyar [Hungarian]	Alulírott, <i>[gyártó neve]</i> nyilatkozom, hogy a <i>[... típus]</i> megfelel a vonatkozó alapvető követelményeknek és az 1999/5/EC irányelv egyéb előírásainak.
 Polski [Polish]	Niniejszym <i>[nazwa producenta]</i> oświadczam, że <i>[nazwa wyrobu]</i> jest zgodny z zasadniczymi wymogami oraz pozostałymi stosownymi postanowieniami Dyrektywy 1999/5/EC.
 Português [Portuguese]	<i>[Nome do fabricante]</i> declara que este <i>[tipo de equipamento]</i> está conforme com os requisitos essenciais e outras disposições da Directiva 1999/5/CE.
 Slovensko [Slovenian]	<i>[Ime proizvajalca]</i> izjavlja, da je ta <i>[tip opreme]</i> v skladu z bistvenimi zahtevami in ostalimi relevantnimi določili direktive 1999/5/ES.
Slovensky	<i>[Meno výrobcu]</i> týmto vyhlasuje, že <i>[typ zariadenia]</i> spĺňa základné požiadavky a

[Slovak]	všetky príslušné ustanovenia Smernice 1999/5/ES.
 Suomi [Finnish]	<i>[Valmistaja = manufacturer]</i> vakuuttaa täten että <i>[type of equipment = laitteen tyyppimerkintä]</i> tyypinen laite on direktiivin 1999/5/EY oleellisten vaatimusten ja sitä koskevien direktiivin muiden ehtojen mukainen.
 Svenska [Swedish]	Härmed intygar <i>[företag]</i> att denna <i>[utrustningstyp]</i> står i överensstämmelse med de väsentliga egenskapskrav och övriga relevanta bestämmelser som framgår av direktiv 1999/5/EG.