

Installing the USB Cable Holder

The USB cable holder is used to stabilize the USB cable so as to prevent it from getting loose when accidentally pulled or moved.

1. Attach the cable holder to the mounting hole by using the provided screw.

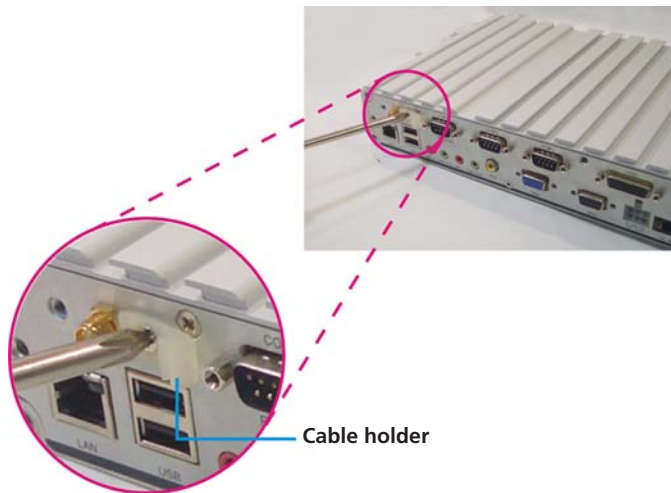

2. Hook the cable to the holder as shown in the photo below.

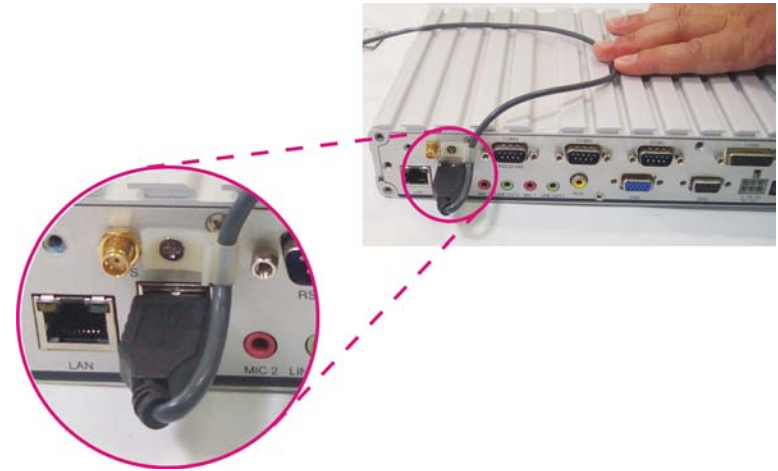

Rackmount Brackets

The rackmount brackets provide a convenient and economical way of mounting the system on the wall.

1. The mounting holes are located at the bottom of the system. Secure the brackets on each side of the system using the provided mounting screws.

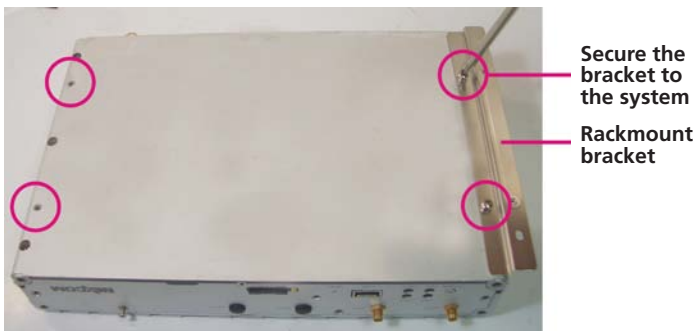

2. Now mount the system on the wall by fastening screws through the bracket's mounting holes.



APPENDIX A: I/O ADDRESS FUNCTION

GPIO LED / UMTS LED / Ignition Status

I/O port : 0EE0H

Bit	Function Description
Bit 0	GPIO LED 0: OFF (default) 1: ON
Bit 1	UMTS LED 0: LED for WLAN (default) 1: LED for 3.5G and WLAN
Bit 2	Ignition (read only) 0: OFF 1: ON
Bit 3	Status of Vehicle Battery 0: Vehicle Battery is OK 1: Vehicle Battery is Low Voltage

Capacity of NEXCOM battery (8 bits)

I/O port : 0EE1H

	Bit0	Bit1	Bit2	Bit3	Bit4	Bit5	Bit6	Bit7
Description	8 bits data (Bit 7 is highest bit of data)							

Voltage of NEXCOM battery (8 bits)

I/O port : 0EE2H

	Bit0	Bit1	Bit2	Bit3	Bit4	Bit5	Bit6	Bit7
Description	8 bits data (Bit 7 is highest bit of data)							

Status of NEXCOM battery (8 bits)

I/O port : 0EE3H

Bit	Function Description
Bit 0	Status for G sensor detection 0: Normal 1: Abnormal (X-axis or Y-axis degree is about 90 or -90)
Bit 1	Power mode 0: 24V system 1: 12V system
Bit 2	Fan mode 0: Auto 1: Always on
Bit 3	Status of Smart battery 0: No discharging 1: Discharging
Bit 4	Status of Fan R 0: Well 1: Failed
Bit 5	Status of Fan R 0: Action 1: Inaction
Bit 6	Status of Fan L 0: Well 1: Failed
Bit 7	Status of Fan L 0: Action 1: Inaction

GPIO

I/O port : 0EE4H

Bit	Function Description
Bit 0-3	GPO 1-4
Bit 4-7	GPI 1-4

WDT

I/O port : 0EE5H

Bit	Function Description
Bit 3	WDT Disable/Enable 0: Disable (default) 1: Enable

Bit 2, 1, 0: Time Setting

Bit 2~0	Time (sec)
000	1 (default)
001	2
010	4
011	8
100	16
101	32
110	64
111	128

Auto clear WDT timer when reading/writing I/O port 0EE5H.

Onboard Module Disable/Enable

I/O port : 0EE6H

Bit	Function Description
Bit 0	3.5G module 0: Disable 1: Enable (default)
Bit 1	WLAN module 0: Disable 1: Enable (default)
Bit 2	External +12V power 0: Disable 1: Enable (default)
Bit 3	External +5V power 0: Disable 1: Enable (default)

APPENDIX B: ICES200-L24 COM EXPRESS CPU MODULE

Overview

ICES 200 is a Type 2 COM Express Module that features Intel® 945GME and ICH7M chipset; switch supports Intel® Core™ 2 Duo and Intel® Core™ 2 Duo LV processors with 533/667 MHz FSB. One DDR2 memory socket supports up to 2GB. The ICES 200 is integrated with Intel® Graphics Media Accelerator (GMA950) and expands via PCI Express Graphics x16 lanes to the carrier board. It also supports other display interfaces including LFP or Dual channel LVDS.

The high performance ICES 200 COM Express Module supports 2 x SATA, 8 x USB 2.0 and 4 PCIe x1 Lanes through the carrier board.

Key Features

- Intel® Socket M supports Core™ 2 Duo / Core™ 2 Duo LV Processor Family
- Intel® 945GME Chipset
- One DDR2 SO-DIMM socket supports un-buffered non-ECC DDR2 533/667 up to 2GB
- Supports 2 x Serial ATA for high speed drives, 8 x USB 2.0 for fast peripherals
- Type 2 COM Express Module supports up to 21 Express lanes, 32 bit PCI interface, one IDE and Gigabit LAN

Specifications

CPU Support

- Supports Intel® Socket M, Core™ 2 Duo Family Processors
- Supports 533/667MHz FSB CPU

Main Memory

- 1 x DDR2 SO-DIMM socket

Chipset

- Intel® 945GME
- ICH7M I/O Controller Hub

BIOS

- Award System BIOS
- Plug & Play support
- 8Mbit Flash ROM

Onboard LAN

- Realtek PCI Express GbE 8111C-GR
- Supports PXE LAN boot function
- Supports Wake on LAN

Display

- Integrated with Intel® Graphics Media Accelerator (GMA950) or expand via PCI Express Graphics x16 lanes / Dual SDVO
- CRT resolution up to 2048 x 1536 @ 60Hz, 1600 x 1200 @ 85Hz
- One PCI Express x16 Lane down to the carrier board
- Supports LFP (Local Flat Panel) LVDS interface with resolution up to 1366 x 768
- Supports Single channel for 18 bit / Dual Channel for 18 bit

Audio

- HD audio interface

COM Express Connectors

- AB
 - VGA / LVDS / 8 x USB 2.0 / HD Audio / 2 x SATA / LAN / GPIO / LPC bus / 1 x PCIe x4 / 1 x PCIe x1 / 5 x PCIe x1 / SMBus (I2C) / SPI BIOS
- CD
 - PCIe x16 / IDE / PCI

System Monitor

- Derived from HW monitor
- Monitors 4 voltages, 2 temperatures and 1 fan speed
- 4 voltages (For +3.3 V, +5 V, +12 V, Vcore)
- 2 temperatures (CPU and one external Temperature Sensor)

Power Requirements

- + 12 V, + 5 VSB, + 3.3 V RTC

■ ■ ■

Dimensions

- COM Express Basic Module Type 2
- 95mm x 125mm

Mechanical Dimensions

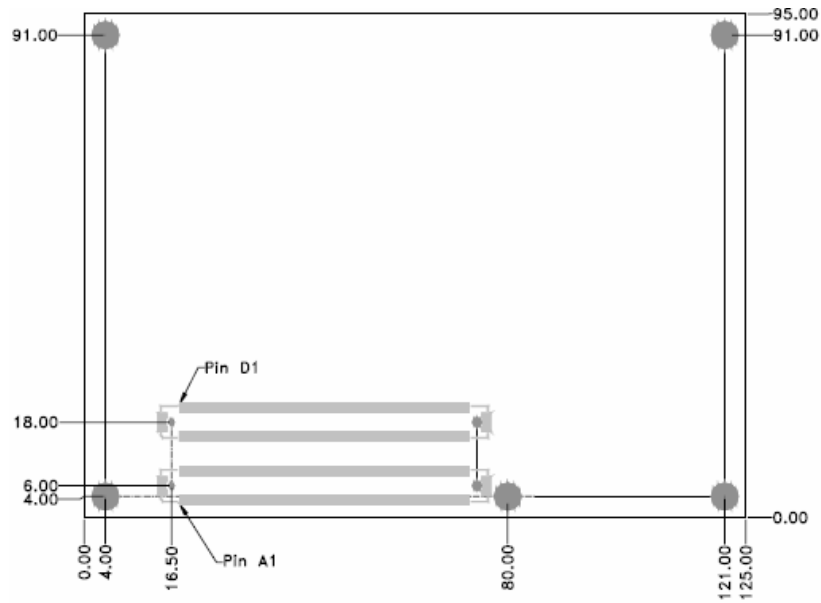

PCI Routing

Slot / Device Signal	Slot / Device 0	Slot / Device 1	Slot / Device 2	Slot / Device 3
IDSEL	AD20	AD21	AD22	AD23
INTA#	IRQA	IRQB	IRQC	IRQD
INTB#	IRQB	IRQC	IRQD	IRQA
INTC#	IRQC	IRQD	IRQA	IRQB
INTD#	IRQD	IRQA	IRQB	IRQC

COM Express Module Connector

COM Express Module Connector

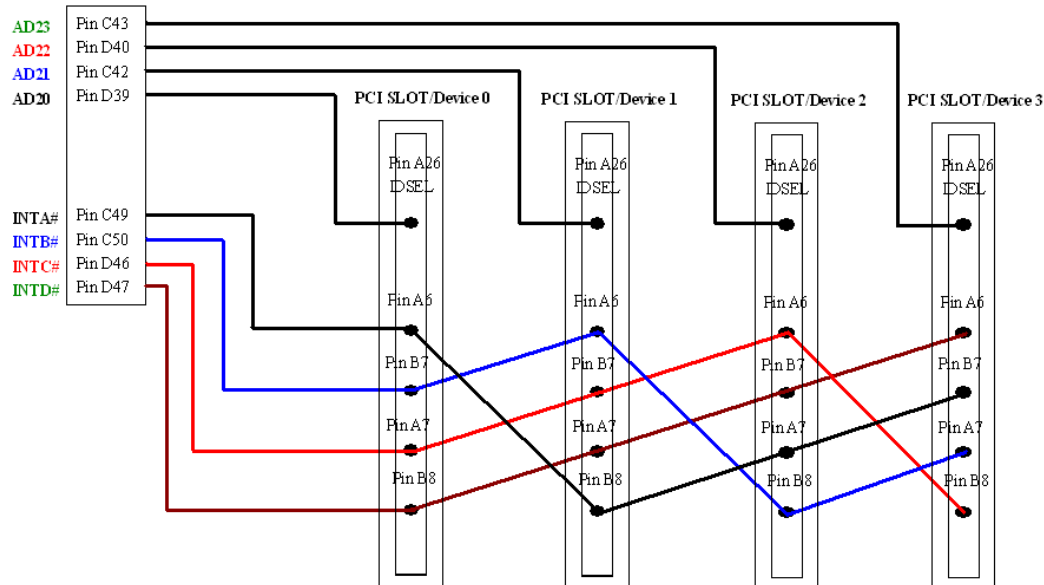

Connectors

High Speed Board-to-Board Connector: COM Express Row A and Row B

Connector size: 2 X 110 = 220 Pins

Connector location: J2



Connector Pin Definition

Row A		Row B		Row A		Row B	
A1	GND	B1	GND	A56	PCIE_TX4-	B56	PCIE_RX4-
A2	GBE0_MDI3-	B2	GBE0_ACT#	A57	GND	B57	GPO2
A3	GBE0_MDI3+	B3	LPC_FRAME#	A58	PCIE_TX3+	B58	PCIE_RX3+
A4	GBE0_LINK100#	B4	LPC_AD0	A59	PCIE_TX3-	B59	PCIE_RX3-
A5	GBE0_LINK1000#	B5	LPC_AD1	A60	GND	B60	GND
A6	GBE0_MDI2-	B6	LPC_AD2	A61	PCIE_TX2+	B61	PCIE_RX2+
A7	GBE0_MDI2+	B7	LPC_AD3	A62	PCIE_TX2-	B62	PCIE_RX2-
A8	GBE0_LINK#	B8	LPC_DRQ0#	A63	GPI1	B63	GPO3
A9	GBE0_MDI1-	B9	LPC_DRQ1#	A64	PCIE_TX1+	B64	PCIE_RX1+
A10	GBE0_MDI1+	B10	LPC_CLK	A65	PCIE_TX1-	B65	PCIE_RX1-
A11	GND	B11	GND	A66	GND	B66	WAKE0#
A12	GBE0_MDI0-	B12	PWRBTN#	A67	GPI2	B67	WAKE1#

Row A		Row B		Row A		Row B	
A13	GBE0_MDI0+	B13	SMB_CK	A68	PCIE_TX0+	B68	PCIE_RX0+
A14	GBE0_CTREF	B14	SMB_DAT	A69	PCIE_TX0-	B69	PCIE_RX0-
A15	SUS_S3#	B15	SMB_ALERT#	A70	GND	B70	GND
A16	SATA0_TX+	B16	SATA1_TX+	A71	LVDS_A0+	B71	LVDS_B0+
A17	SATA0_TX-	B17	SATA1_TX-	A72	LVDS_A0-	B72	LVDS_B0-
A18	SUS_S4#	B18	SUS_STAT#	A73	LVDS_A1+	B73	LVDS_B1+
A19	SATA0_RX+	B19	SATA1_RX+	A74	LVDS_A1+	B74	LVDS_B1-
A20	SATA0_RX-	B20	SATA1_RX-	A75	LVDS_A2+	B75	LVDS_B2+
A21	GND	B21	GND	A76	LVDS_A2+	B76	LVDS_B2-
A22	NC	B22	NC	A77	LVDS_VDD_EN	B77	LVDS_B3+
A23	NC	B23	NC	A78	LVDS_A3+	B78	LVDS_B3-
A24	SUS_S5#	B24	PWR_OK	A79	LVDS_A3+	B79	LVDS_BKLT_EN
A25	NC	B25	NC	A80	GND	B80	GND
A26	NC	B26	NC	A81	LVDS_A_CK+	B81	LVDS_B_CK+
A27	BATLOW#	B27	NC	A82	LVDS_A_CK-	B82	LVDS_B_CK-
A28	ATA_ACT#	B28	AC_SDIN2	A83	LVDS_I2C_CK	B83	LVDS_BKLT_CTRL
A29	AC_SYNC	B29	AC_SDIN1	A84	LVDS_I2C_DAT	B84	VCC_5V_SBY
A30	AC_RST#	B30	AC_SDIN0	A85	GPI3	B85	VCC_5V_SBY
A31	GND	B31	GND	A86	KBD_RST#	B86	VCC_5V_SBY
A32	AC_BITCLK	B32	SPKR	A87	KBD_A20GATE	B87	VCC_5V_SBY
A33	AC_SDOOUT	B33	I2C_CK	A88	PCIE0_CK_REF+	B88	RSVD
A34	BIOS_DISABLE#	B34	I2C_DAT	A89	PCIE0_CK_REF-	B89	VGA_RED
A35	THRMTRIP#	B35	THRM#	A90	GND	B90	GND
A36	USB6-	B36	USB7-	A91	RSVD	B91	VGA_GRN
A37	USB6+	B37	USB7+	A92	RSVD	B92	VGA_BLU
A38	USB_6_7_OC#	B38	USB_4_5_OC#	A93	GPO0	B93	VGA_HSYNC
A39	USB4-	B39	USB5-	A94	RSVD	B94	VGA_VSYNC

Row A		Row B		Row A		Row B	
A40	USB4+	B40	USB5+	A95	RSVD	B95	VGA_I2C_CK
A41	GND	B41	GND	A96	GND	B96	VGA_I2C_DAT
A42	USB2-	B42	USB3-	A97	VCC_12V	B97	NC
A43	USB2+	B43	USB3+	A98	VCC_12V	B98	NC
A44	USB_2_3_OC#	B44	USB_0_1_OC#	A99	VCC_12V	B99	NC
A45	USB0-	B45	USB1-	A100	GND	B100	GND
A46	USB0+	B46	USB1+	A101	VCC_12V	B101	VCC_12V
A47	VCC_RTC	B47	NC	A102	VCC_12V	B102	VCC_12V
A48	EXCD0_PERST#	B48	NC	A103	VCC_12V	B103	VCC_12V
A49	EXCD0_CPPE#	B49	SYS_RESET#	A104	VCC_12V	B104	VCC_12V
A50	LPC_SERIRQ	B50	CB_RESET#	A105	VCC_12V	B105	VCC_12V
A51	GND	B51	GND	A106	VCC_12V	B106	VCC_12V
A52	NC	B52	NC	A107	VCC_12V	B107	VCC_12V
A53	NC	B53	NC	A108	VCC_12V	B108	VCC_12V
A54	GPIO	B54	GPO1	A109	VCC_12V	B109	VCC_12V
A55	PCIE_TX4+	B55	PCIE_RX4+	A110	GND	B110	GND

High Speed Board-to-Board Connector: COM Express Row C and Row D

Connector size: 2 X 110 = 220 Pins
Connector location: J1



Connector Pin Definition

Row C		Row D		Row C		Row D	
C1	GND	D1	GND	C56	PEG_RX1-	D56	PEG_TX1-
C2	IDE_D7	D2	IDE_D5	C57	TYPE1#	D57	TYPE2#
C3	IDE_D6	D3	IDE_D10	C58	PEG_RX2+	D58	PEG_TX2+
C4	IDE_D3	D4	IDE_D11	C59	PEG_RX2-	D59	PEG_TX2-
C5	IDE_D15	D5	IDE_D12	C60	GND	D60	GND
C6	IDE_D8	D6	IDE_D4	C61	PEG_RX3+	D61	PEG_TX3+
C7	IDE_D9	D7	IDE_D0	C62	PEG_RX3-	D62	PEG_TX3-
C8	IDE_D2	D8	IDE_REQ	C63	RSVD	D63	RSVD
C9	IDE_D13	D9	IDE_IOW#	C64	RSVD	D64	RSVD
C10	IDE_D1	D10	IDE_ACK#	C65	PEG_RX4+	D65	PEG_TX4+
C11	GND	D11	GND	C66	PEG_RX4-	D66	PEG_TX4-
C12	IDE_D14	D12	IDE_IRQ	C67	RSVD	D67	GND

Row C		Row D		Row C		Row D	
C13	IDE_IORDY	D13	IDE_A0	C68	PEG_RX5+	D68	PEG_TX5+
C14	IDE_IOR#	D14	IDE_A1	C69	PEG_RX5-	D69	PEG_TX5-
C15	PCI_PME#	D15	IDE_A2	C70	GND	D70	GND
C16	PCI_GNT2#	D16	IDE_CS1#	C71	PEG_RX6+	D71	PEG_TX6+
C17	PCI_REQ2#	D17	IDE_CS3#	C72	PEG_RX6-	D72	PEG_TX6-
C18	PCI_GNT1#	D18	IDE_RESET#	C73	SDVO_DATA	D73	SDVO_CLK
C19	PCI_REQ1#	D19	PCI_GNT3#	C74	PEG_RX7+	D74	PEG_TX7+
C20	PCI_GNT0#	D20	PCI_REQ3#	C75	PEG_RX7-	D75	PEG_TX7-
C21	GND	D21	GND	C76	GND	D76	GND
C22	PCI_REQ0#	D22	PCI_AD1	C77	RSVD	D77	IDE_CBLID#
C23	PCI_RESET#	D23	PCI_AD3	C78	PEG_RX8+	D78	PEG_TX8+
C24	PCI_AD0	D24	PCI_AD5	C79	PEG_RX8-	D79	PEG_TX8-
C25	PCI_AD2	D25	PCI_AD7	C80	GND	D80	GND
C26	PCI_AD4	D26	PCI_C/BE0#	C81	PEG_RX9+	D81	PEG_TX9+
C27	PCI_AD6	D27	PCI_AD9	C82	PEG_RX9-	D82	PEG_TX9-
C28	PCI_AD8	D28	PCI_AD11	C83	RSVD	D83	RSVD
C29	PCI_AD10	D29	PCI_AD13	C84	GND	D84	GND
C30	PCI_AD12	D30	PCI_AD15	C85	PEG_RX10+	D85	PEG_TX10+
C31	GND	D31	GND	C86	PEG_RX10-	D86	PEG_TX10-
C32	PCI_AD14	D32	PCI_PAR	C87	GND	D87	GND
C33	PCI_C/BE1#	D33	PCI_SERR#	C88	PEG_RX11+	D88	PEG_TX11+
C34	PCI_PERR#	D34	PCI_STOP#	C89	PEG_RX11-	D89	PEG_TX11-
C35	PCI_LOCK#	D35	PCI_TRDY#	C90	GND	D90	GND
C36	PCI_DEVSEL#	D36	PCI_FRAME#	C91	PEG_RX12+	D91	PEG_TX12+
C37	PCI_IRDY#	D37	PCI_AD16	C92	PEG_RX12-	D92	PEG_TX12-
C38	PCI_C/BE2#	D38	PCI_AD18	C93	GND	D93	GND
C39	PCI_AD17	D39	PCI_AD20	C94	PEG_RX13+	D94	PEG_TX13+

Row C		Row D		Row C		Row D	
C40	PCI_AD19	D40	PCI_AD22	C95	PEG_RX13-	D95	PEG_TX13-
C41	GND	D41	GND	C96	GND	D96	GND
C42	PCI_AD21	D42	PCI_AD24	C97	RSVD	D97	PEG_ENABLE#
C43	PCI_AD23	D43	PCI_AD26	C98	PEG_RX14+	D98	PEG_TX14+
C44	PCI_C/BE3#	D44	PCI_AD28	C99	PEG_RX14-	D99	PEG_TX14-
C45	PCI_AD25	D45	PCI_AD30	C100	GND	D100	GND
C46	PCI_AD27	D46	PCI_IRQC#	C101	PEG_RX15+	D101	PEG_TX15+
C47	PCI_AD29	D47	PCI_IRQD#	C102	PEG_RX15-	D102	PEG_TX15-
C48	PCI_AD31	D48	PCI_CLKRUN#	C103	GND	D103	GND
C49	PCI_IRQA#	D49	PCI_M66EN	C104	VCC_12V	D104	VCC_12V
C50	PCI_IRQB#	D50	PCI_CLK	C105	VCC_12V	D105	VCC_12V
C51	GND	D51	GND	C106	VCC_12V	D106	VCC_12V
C52	PEG_RX0+	D52	PEG_TX0+	C107	VCC_12V	D107	VCC_12V
C53	PEG_RX0-	D53	PEG_TX0-	C108	VCC_12V	D108	VCC_12V
C54	TYPE0#	D54	PEG_LANE_RV#	C109	VCC_12V	D109	VCC_12V
C55	PEG_RX1+	D55	PEG_TX1+	C110	GND	D110	GND

PCIE 1X4 or PCIE 4X1 SWITCH

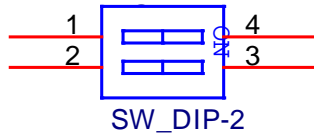

Pin	Status	Config
1 and 2	OFF	PCIE 4X1
1 and 2	ON	PCIE 1X4

APPENDIX C: VTCB6110 CARRIER BOARD

Specifications

Expansion

- 1 PCI-104 socket
- 1 Bluetooth module (optional)
- 2 Mini PCI Express socket
 - 1 PCIe interface for WLAN module
 - 1 PCIe + USB interface for 3.5G module

Storage

- One SATA 2.5" HDD bay
- One internal Type I/II CompactFlash socket

I/O Interfaces - Front

- 4 SMA-type mounting holes for WLAN, HSDPA and Bluetooth
- 1 power button
- 1 reset switch
- 1 SIM card socket
- 1 USB 2.0
- 4 LEDs for Standby, HDD, WLAN/HSDPA and GPO
- 1 line-out
- 1 mic-in

I/O Interfaces - Front

- 4 SMA-type mounting holes for WLAN, HSDPA and Bluetooth
- 1 power button
- 1 reset switch
- 1 SIM card socket
- 1 USB 2.0
- 4 LEDs for Standby, HDD, WLAN/HSDPA and GPO
- 1 line-out
- 1 mic-in

Dimensions

- 260mm(W) x 176mm(D) x 50mm(H)
10.24"(W) x 7"(D) x 1.97"(H)

Jumpers and Connectors

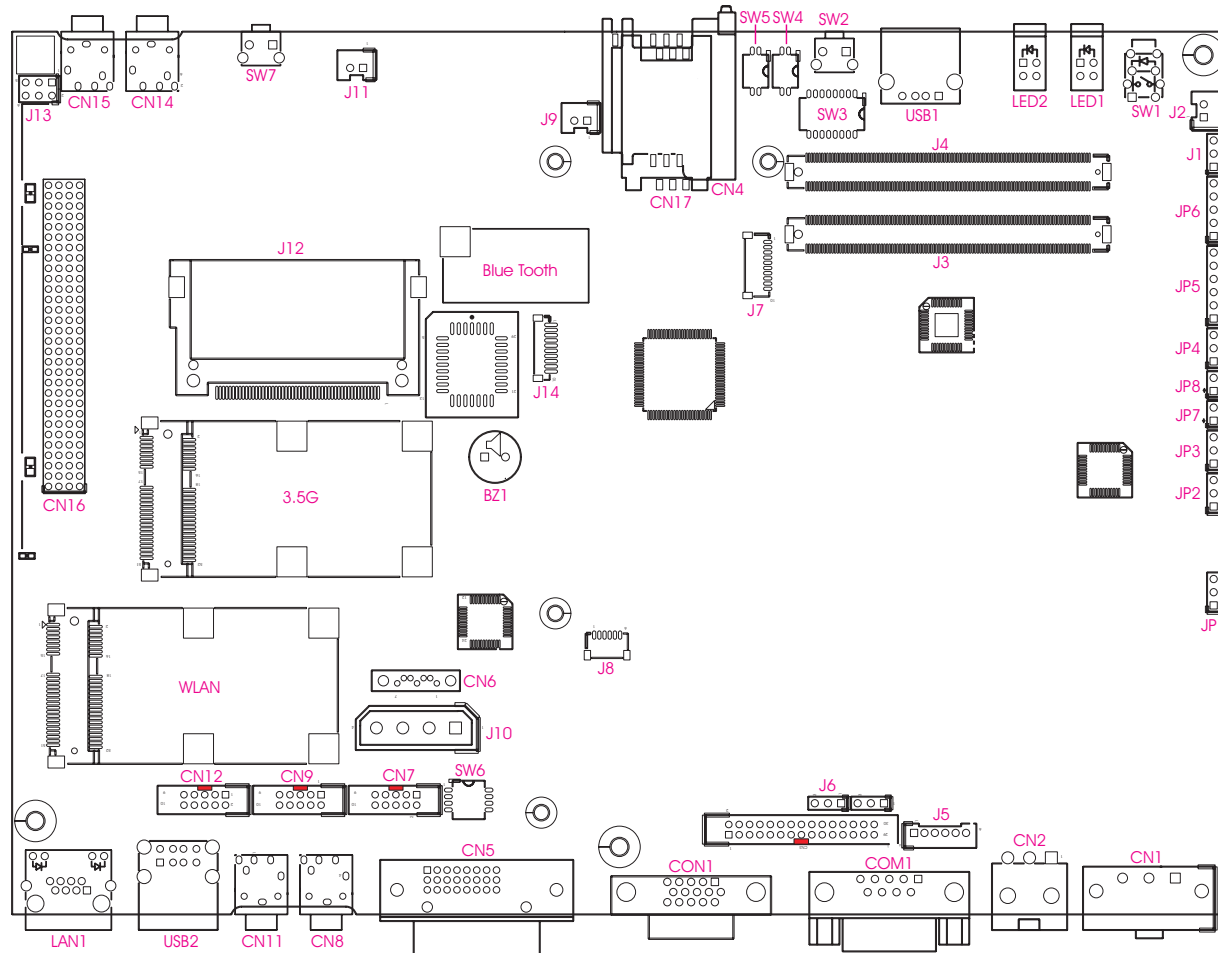

Jumper Settings

SW5: Input Voltage Selection

SW5 / Input Voltage	12V (default)	24V	6V~36V
SW5.1	OFF	OFF	ON
SW5.2	OFF	ON	Ignore

SW6: COM Port Mode Selection

SW6 COM Port Mode	RS232 (default)	RS485
SW6.1	OFF	ON
SW6.2	OFF	ON
SW6.3	OFF	ON

CF (IDE0) Primary Master/Slave Select (JP4)

Pin	Status	Function Description
1-2	Short	Slave
2-3 (default)	Short (default)	Master

LVDS Power Input Voltage Select (JP9)

Pin	Status	Function Description
1-2	Short	+5V IN
2-3 (default)	Short (default)	+3.3V IN

CMOS Input Voltage Select (J6)

Pin	Status	Function Description
1-2 (default)	Short (default)	VBAT IN
2-3	Short	Clear CMOS

BIOS Function Select (J1)

Pin	Status	Function Description
1-2	Short	Disable carrier board BIOS
2-3 (default)	Short (default)	Disable module board BIOS

DC Input Voltage Select (JP1)

Pin	Status	Function Description
1-2 (default)	Short (default)	IGNITION
2-3	Short	VIN_M

Temp Sensor (JP8)

Pin	Function Description
1	SENSOR+
2	GND

Auto Power Select (JP2)

Pin	Status	Function Description
1-2 (default)	Short (default)	AUTO
2-3	Short	BUTTON CONTROL

PCI-104 VI/O Select Voltage (J13)

Pin	Status	Function Description
1-4(*)	Short*	+3.3V
3-6	Short	+5V

MCU Download (JP6)

Pin	Function Description
1	+V3.3ALW
2	C2D
3	MRST
4	C2CK
5	GND

GAL Download (JP5)

Pin	Function Description
1	+V3.3S
2	GND
3	TCK
4	TDO
5	TDI
6	TMS

MCU COM Port (JP3)

Pin	Function Description
1	TX
2	RX
3	GND

Connectors

High Speed Board-to-Board Connector: COM Express Row A and Row B

Connector size: 2 x 110 = 220 pins

Connector location: J4



Connector Pin Definition

Row A		Row B		Row A		Row B	
A1	GND	B1	GND	A56	NC	B56	NC
A2	GBE0_MDI3-	B2	GBE0_ACT#	A57	GND	B57	NC
A3	GBE0_MDI3+	B3	LPC_FRAME#	A58	NC	B58	NC
A4	NC	B4	LPC_AD0	A59	NC	B59	NC
A5	NC	B5	LPC_AD1	A60	GND	B60	GND
A6	GBE0_MDI2-	B6	LPC_AD2	A61	NC	B61	NC
A7	GBE0_MDI2+	B7	LPC_AD3	A62	NC	B62	NC
A8	GBE0_LINK#	B8	NC	A63	GPI1	B63	GPO3
A9	GBE0_MDI1-	B9	NC	A64	NC	B64	NC
A10	GBE0_MDI1+	B10	LPC_CLK	A65	NC	B65	NC
A11	GND	B11	GND	A66	GND	B66	NC
A12	GBE0_MDI0-	B12	PWRBTN#	A67	NC	B67	NC

Row A		Row B		Row A		Row B	
A13	GBE0_MDI0+	B13	SMB_CK	A68	PCIE_TX0+	B68	PCIE_RX0+
A14	GBE0_CTREF	B14	SMB_DAT	A69	PCIE_TX0-	B69	PCIE_RX0-
A15	SUS_S3#	B15	SMB_ALERT#	A70	GND	B70	GND
A16	SATA0_TX+	B16	NC	A71	LVDS_A0+	B71	NC
A17	SATA0_TX-	B17	NC	A72	LVDS_A0-	B72	NC
A18	SUS_S4#	B18	SUS_STAT#	A73	LVDS_A1+	B73	NC
A19	SATA0_RX+	B19	NC	A74	LVDS_A1+	B74	NC
A20	SATA0_RX-	B20	NC	A75	LVDS_A2+	B75	NC
A21	GND	B21	GND	A76	LVDS_A2+	B76	NC
A22	NC	B22	NC	A77	LVDS_VDD_EN	B77	NC
A23	NC	B23	NC	A78	LVDS_A3+	B78	NC
A24	SUS_S5#	B24	PWR_OK	A79	LVDS_A3+	B79	LVDS_BKLT_EN
A25	NC	B25	NC	A80	GND	B80	GND
A26	NC	B26	NC	A81	LVDS_A_CK+	B81	NC
A27	BATLOW#	B27	NC	A82	LVDS_A_CK-	B82	NC
A28	ATA_ACT#	B28	NC	A83	LVDS_I2C_CK	B83	LVDS_BKLT_CTRL
A29	AC_SYNC	B29	NC	A84	LVDS_I2C_DAT	B84	VCC_5V_SBY
A30	AC_RST#	B30	AC_SDINO	A85	NC	B85	VCC_5V_SBY
A31	GND	B31	GND	A86	NC	B86	VCC_5V_SBY
A32	AC_BITCLK	B32	SPKR	A87	NC	B87	VCC_5V_SBY
A33	AC_SDOUT	B33	I2C_CK	A88	PCIE0_CK_REF+	B88	RSVD
A34	NC	B34	I2C_DAT	A89	PCIE0_CK_REF-	B89	NC
A35	NC	B35	THRM#	A90	GND	B90	GND
A36	USB6-	B36	NC	A91	RSVD	B91	NC
A37	USB6+	B37	NC	A92	RSVD	B92	NC
A38	USB_6_7_OC#	B38	USB_4_5_OC#	A93	NC	B93	NC
A39	USB4-	B39	USB5-	A94	RSVD	B94	NC

Row A		Row B		Row A		Row B	
A40	USB4+	B40	USB5+	A95	RSVD	B95	NC
A41	GND	B41	GND	A96	GND	B96	NC
A42	USB2-	B42	USB3-	A97	VCC_12V	B97	NC
A43	USB2+	B43	USB3+	A98	VCC_12V	B98	NC
A44	USB_2_3_OC#	B44	USB_0_1_OC#	A99	VCC_12V	B99	NC
A45	USB0-	B45	USB1-	A100	GND	B100	GND
A46	USB0+	B46	USB1+	A101	VCC_12V	B101	VCC_12V
A47	VCC_RTC	B47	NC	A102	VCC_12V	B102	VCC_12V
A48	NC	B48	NC	A103	VCC_12V	B103	VCC_12V
A49	NC	B49	SYS_RESET#	A104	VCC_12V	B104	VCC_12V
A50	NC	B50	CB_RESET#	A105	VCC_12V	B105	VCC_12V
A51	GND	B51	GND	A106	VCC_12V	B106	VCC_12V
A52	NC	B52	NC	A107	VCC_12V	B107	VCC_12V
A53	NC	B53	NC	A108	VCC_12V	B108	VCC_12V
A54	NC	B54	NC	A109	VCC_12V	B109	VCC_12V
A55	NC	B55	NC	A110	GND	B110	GND

High Speed Board-to-Board Connector: COM Express Row C and Row D

Connector size: 2 X 110 = 220 Pins

Connector location: J3



Connector Pin Definition

Row C		Row D		Row C		Row D	
C1	GND	D1	GND	C56	NC	D56	SDVOB_GREEN-
C2	IDE_D7	D2	IDE_D5	C57	NC	D57	NC
C3	IDE_D6	D3	IDE_D10	C58	NC	D58	SDVOB_BLUE+
C4	IDE_D3	D4	IDE_D11	C59	NC	D59	SDVOB_BLUE-
C5	IDE_D15	D5	IDE_D12	C60	GND	D60	GND
C6	IDE_D8	D6	IDE_D4	C61	NC	D61	SDVO_CLK+
C7	IDE_D9	D7	IDE_D0	C62	NC	D62	SDVO_CLK-
C8	IDE_D2	D8	IDE_REQ	C63	NC	D63	NC
C9	IDE_D13	D9	IDE_IOW#	C64	NC	D64	NC
C10	IDE_D1	D10	IDE_ACK#	C65	NC	D65	NC
C11	GND	D11	GND	C66	NC	D66	NC
C12	IDE_D14	D12	IDE_IRQ	C67	NC	D67	GND

Row C		Row D		Row C		Row D	
C13	IDE_IORDY	D13	IDE_A0	C68	NC	D68	NC
C14	IDE_IOR#	D14	IDE_A1	C69	NC	D69	NC
C15	NC	D15	IDE_A2	C70	GND	D70	GND
C16	NC	D16	IDE_CS1#	C71	NC	D71	NC
C17	NC	D17	IDE_CS3#	C72	NC	D72	NC
C18	NC	D18	IDE_RESET#	C73	NC	D73	SDVO_CLK
C19	NC	D19	NC	C74	NC	D74	NC
C20	PCI_GNT0#	D20	NC	C75	NC	D75	NC
C21	GND	D21	GND	C76	GND	D76	GND
C22	PCI_REQ0#	D22	PCI_AD1	C77	NC	D77	IDE_CBLID#
C23	PCI_RESET#	D23	PCI_AD3	C78	NC	D78	NC
C24	PCI_AD0	D24	PCI_AD5	C79	NC	D79	NC
C25	PCI_AD2	D25	PCI_AD7	C80	GND	D80	GND
C26	PCI_AD4	D26	PCI_C/BE0#	C81	NC	D81	NC
C27	PCI_AD6	D27	PCI_AD9	C82	NC	D82	NC
C28	PCI_AD8	D28	PCI_AD11	C83	NC	D83	NC
C29	PCI_AD10	D29	PCI_AD13	C84	GND	D84	GND
C30	PCI_AD12	D30	PCI_AD15	C85	NC	D85	NC
C31	GND	D31	GND	C86	NC	D86	NC
C32	PCI_AD14	D32	PCI_PAR	C87	GND	D87	GND
C33	PCI_C/BE1#	D33	PCI_SERR#	C88	NC	D88	NC
C34	PCI_PERR#	D34	PCI_STOP#	C89	NC	D89	NC
C35	PCI_LOCK#	D35	PCI_TRDY#	C90	GND	D90	GND
C36	PCI_DEVSEL#	D36	PCI_FRAME#	C91	NC	D91	NC
C37	PCI_IRDY#	D37	PCI_AD16	C92	NC	D92	NC
C38	PCI_C/BE2#	D38	PCI_AD18	C93	GND	D93	GND
C39	PCI_AD17	D39	PCI_AD20	C94	NC	D94	NC

Row C		Row D		Row C		Row D	
C40	PCI_AD19	D40	PCI_AD22	C95	PEG_RX13-	D95	PEG_TX13-
C41	GND	D41	GND	C96	GND	D96	GND
C42	PCI_AD21	D42	PCI_AD24	C97	RSVD	D97	PEG_ENABLE#
C43	PCI_AD23	D43	PCI_AD26	C98	PEG_RX14+	D98	PEG_TX14+
C44	PCI_C/BE3#	D44	PCI_AD28	C99	PEG_RX14-	D99	PEG_TX14-
C45	PCI_AD25	D45	PCI_AD30	C100	GND	D100	GND
C46	PCI_AD27	D46	PCI_IRQC#	C101	PEG_RX15+	D101	PEG_TX15+
C47	PCI_AD29	D47	PCI_IRQD#	C102	PEG_RX15-	D102	PEG_TX15-
C48	PCI_AD31	D48	PCI_CLKRUN#	C103	GND	D103	GND
C49	PCI_IRQA#	D49	PCI_M66EN	C104	VCC_12V	D104	VCC_12V
C50	PCI_IRQB#	D50	PCI_CLK	C105	VCC_12V	D105	VCC_12V
C51	GND	D51	GND	C106	VCC_12V	D106	VCC_12V
C52	PEG_RX0+	D52	PEG_TX0+	C107	VCC_12V	D107	VCC_12V
C53	PEG_RX0-	D53	PEG_TX0-	C108	VCC_12V	D108	VCC_12V
C54	TYPE0#	D54	PEG_LANE_RV#	C109	VCC_12V	D109	VCC_12V
C55	PEG_RX1+	D55	PEG_TX1+	C110	GND	D110	GND

CompactFlash Connector

Connector size: 2 x 25 = 50 pins

Connector location: J12

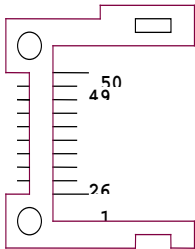

Connector Pin Definition

Pin	Description	Pin	Description
1	Gnd	2	Data 3
3	Data 4	4	Data 5
5	Data 6	6	Data 7
7	HDC CS100	8	Gnd
9	Gnd	10	Gnd
11	Gnd	12	Gnd
13	+5V	14	Gnd
15	Gnd	16	Gnd
17	Gnd	18	Disk Address 2
19	Disk Address 1	20	Disk Address 0
21	Data 0	22	Data 1

Pin	Description	Pin	Description
23	Data 2	24	IOCS16# (NC)
25	CF_CD2# (Pull-down)	26	CF_CD1# (Pull-down)
27	Data 11	28	Data 12
29	Data 13	30	Data 14
31	Data 15	32	HDC CS300
33	CF_VS1# (NC)	34	IOR
35	IOW	36	CF_WE# (+5V)
37	Interrupt 15	38	+5V
39	CF_CSEL# (Master or Slave)	40	CF_VS2# (NC)
41	Reset #	42	IOCHRDY
43	DMA REQ / DACK (NC)	44	DMA ACK# /CF_REG# (+5V)
45	HDD Active Led	46	DMA66 Detect / CF_PDIAG#
47	Data 8	48	Data 9
49	Data 10	50	Gnd

GPIO Connector

Connector size: DSUB-9 pin
 Connector location: COM1

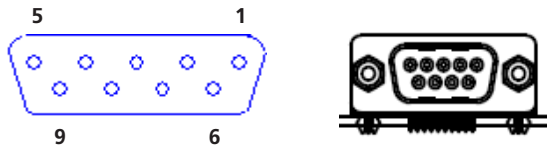

Connector Pin Definition

Pin	Description	Pin	Description
1	GIN1	2	GIN2
3	GIN3	4	GIN4
5	GOUT4	6	GOUT1
7	GOUT2	8	GOUT3
9	GND		

RS232 Connector: COM1, COM2

Connector size: 2 x 10 = 20 Pins Pin Header, (2.0 mm Pitch)
 Connector location: COM1 (CN9), COM2 (CN7)

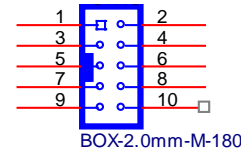

Connector Pin Definition

Pin	Definition	Pin	Definition
1	DCD	2	RXD
3	TXD	4	DTR
5	Gnd	6	DSR
7	RTS	8	CTS
9	RI		

RS232/485 Connector: COM3

Connector size: 2 x 10 = 20 Pins Pin Header, (2.0 mm Pitch)

Connector location: CN12

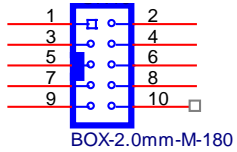

Connector Pin Definition

Pin	Definition	Pin	Definition
1	DCD (RS232) TX-/RX- (RS485)	2	RXD (RS232) TX+/RX+ (RS485)
3	TXD (RS232)	4	DTR (RS232)
5	Gnd	6	DSR (RS232)
7	RTS (RS232)	8	CTS (RS232)
9	RI (RS232)		

GAL Programmer PIN Header

Connector size: 2.54mm-M-180

Connector location: JP5

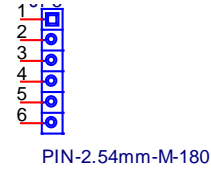

Connector Pin Definition

Pin	Definition	Pin	Definition
1	+3.3V	2	GND
3	TCK	4	TDO
5	TDI	6	TMS

MCU Programmer Pin Header

Connector size: 2.54mm-M-180

Connector location: JP6

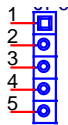

PIN-2.54mm-M-180

Connector Pin Definition

Pin	Definition	Pin	Definition
1	+3.3ALW	2	C2D
3	MRST	4	C2CK
5	GND		

VGA Connector

Connector size: DSUB-15

Connector location: CON1

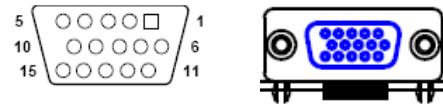

Connector Pin Definition

Pin	Definition	Pin	Definition
1	RED	2	GREEN
3	BLUE	4	NC
5	Gnd	6	Gnd
7	Gnd	8	Gnd
9	VCC	10	Gnd
11	NC	12	DDCDAT
13	Hsync	14	Vsync
15	DDCCLK		

LVDS Connector + USB0

Connector size: 2 x 15 (2.0mm)

Connector location: CN3

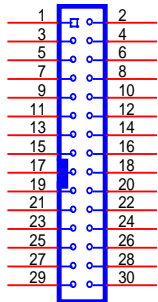

BOX-2.0mm-M-180

Pin	Definition	Pin	Definition
17	LVDS_5(OUT2)	18	Panel_backlight(+12V)
19	LVDS_4(OUT2#)	20	Panel_backlight(+12V)
21	LVDS_GND	22	Power on push button
23	USB_0#	24	USB_GND
25	USB_0	26	USB_VCC (+5V)
27	USB_GND	28	USB_GND
29	Panel_backlight(+12V)	30	GND

Connector Pin Definition

Pin	Definition	Pin	Definition
1	LVDS_CLK	2	LVDS_DAT
3	Panel_VDD	4	LVDS_1(OUT0)
5	LVDS_9(OUT3)	6	LVDS_0(OUT0#)
7	LVDS_8(OUT3#)	8	Panel_VDD
9	LVDS_GND	10	LVDS_GND
11	LVDS_7(CLK)	12	LVDS_3(OUT1)
13	LVDS_6(CLK#)	14	LVDS_2(OUT1#)
15	LVDS_GND	16	LVDS_GND

LAN Connector

Connector size: RJ-45

Connector location: LAN1



Connector Pin Definition

Pin	Definition	Pin	Definition
1	TX+	2	TX-
3	RX+	4	N/C1
5	N/C2	6	RX-
7	N/C3	8	N/C4
9	LAN Speed LED	10	+3.3V
11	LAN Link LED	12	+3.3V

USB Connector

Connector location: USB1



Connector Pin Definition

Pin	Definition	Pin	Definition
1	VCC	2	DATA-
3	DATA+	4	GND

USB Connector

Connector location: USB2



Connector Pin Definition

Pin	Definition	Pin	Definition
1	VCC	2	DATA1-
3	DATA1+	4	GND
5	VCC	6	DATA-
7	DATA+	8	GND

LVDS Power Connector

Connector location: J5



Connector Pin Definition

Pin	Definition	Pin	Definition
1	Panel_backlight	2	Panel_VDD
3	GND	4	GND
5	LVDS_PANEL	6	LVDS_BIASON

External 12V & 5V Power and SMBUS Connector

Connector location: CN2

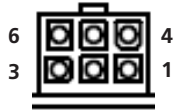

Connector Pin Definition

Pin	Definition	Pin	Definition
1	5V	2	12V
3	SMBCLK	4	GND
5	GND	6	SMBDATA

Mic-in

Connector location: CN11 and CN15



Connector Pin Definition

Pin	Definition	Pin	Definition
1	NC	2	MIC_JD
3	NC	4	MIC_OUT
5	GND	6	GND

Line-out

Connector location: CN8 and CN14



Connector Pin Definition

Pin	Definition	Pin	Definition
1	LINE_OUT_L	2	SURR_JD
3	NC	4	LINE_OUT_R
5	GND	6	GND

PCI-104 VI/O Voltage Setting

Connector location: J13

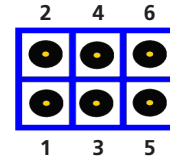

Connector Pin Definition

Pin No.	Status	Function Description
1-3, 2-4 (default)	Short	+3.3V
3-5, 4-6	Short	+5V

PCI-104 Connector

Connector location: CN16

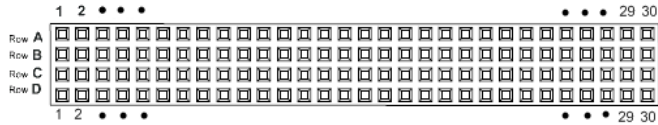

Connector Pin Definition

Pin	A	B	C	D
1	GND	Reserved	+5	AD00
2	VI/O	AD02	AD01	+5V
3	AD05	GND	AD04	AD03
4	C/BE0#	AD07	GND	AD06
5	GND	AD09	AD08	GND
6	AD11	VI/O	AD10	M66EN
7	AD14	AD13	GND	AD12
8	+3.3V	C/BE1#	AD15	+3.3V
9	SERR#	GND	Reserved	PAR
10	GND	PERR#	+3.3V	Reserved
11	STOP#	+3.3V	LOCK#	GND
12	+3.3V	TRDY#	GND	DEVSEL#
13	FRAME#	GND	IRDY#	+3.3V
14	GND	AD16	+3.3V	C/BE2#
15	AD18	+3.3V	AD17	GND
16	AD21	AD20	GND	AD19
17	+3.3V	AD23	AD22	+3.3V
18	IDSEL0	GND	IDSEL1	IDSEL2
19	AD24	C/BE3#	VI/O	IDSEL3
20	GND	AD26	AD25	GND
21	AD29	+5V	AD28	AD27
22	+5V	AD30	GND	AD31
23	REQ0#	GND	REQ1#	VI/O
24	GND	REQ2#	+5V	GNT0#
25	GNT1#	VI/O	GNT2#	GND
26	+5V	CLK0	GND	CLK1
27	CLK2	+5V	CLK3	GND
28	GND	INTD#	+5V	RST#
29	+12V	INTA#	INTB#	INTC#
30	-12V	REQ3#	GNT3#	GND

Power Button

Connector location: SW1

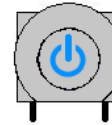

Reset Button

Connector location: SW2



MCU COM Port

Connector location: JP3

Connector Pin Definition

Pin	Function Description
1	TX
2	RX
3	GND

ACC_ON LED

Connector location: JP7



Connector Pin Definition

Pin	Function Description
1	+3.3V LED
2	GND

Temp Sensor

Connector location: JP8



Connector Pin Definition

Pin	Function Description
1	SENSOR+
2	GND

DC Power Input Connector

Connector location: CN1



Connector Pin Definition

Pin	Function Description
1	GND
2	VIN (6V~36V)
3	IGNITION

Power On and IDE Active LED

Connector location: LED1



Connector Pin Definition

LED	Function Description
T1	POWER LED
B1	HD LED

GPIO and UMTS LEDs

Connector location: LED2

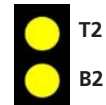

LED I/O Port Address and Data

LED	Function Description
T2	I/O PORT Address: 0EE0; Bit0: 1 (Light), 0 (Dark)
B2	UMTS STATUS

Serial ATA

Connector location: CN6



Connector Pin Definition

Pin	Definition	Pin	Definition
1	GND	2	SATA_TXP0 -
3	SATA_TXN0	4	GND
5	SATA_RXN0	6	SATA_RXP0
7	GND		

Serial ATA Power Input

Connector location: J10



Connector Pin Definition

Pin	Definition	Pin	Definition
1	+V12S	2	GND
3	GND	4	+V5S

Mini-PCIe Socket (for 3.5G module) PCIe Interface

Connector location: CN10

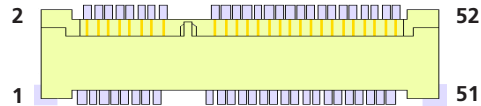

Connector Pin Definition

Pin	Definition	Pin	Definition	Pin	Definition	Pin	Definition
1	MIC +	2	+V3.3S	27	GND	28	NC
3	MIC -	4	GND	29	GND	30	NC
5	SPK +	6	NC	31	NC	32	NC
7	GND	8	USIM PWR	33	RESET	34	GND
9	GND	10	USIM DATA	35	GND	36	USB_D-
11	VCC_MSM26_DIG	12	USIM CLK	37	GND	38	USB_D+
13	NC	14	USIM RST	39	+V3.3S	40	GND
15	GND	16	NC	41	+V3.3S	42	LED_WWAN#
17	NC	18	GND	43	GND	44	NC
19	NC	20	W_DISABLE#	45	NC	46	NC
21	GND	22	NC	47	NC	48	NC
23	NC	24	NC	49	NC	50	GND
25	NC	26	GND	51	NC	52	+V3.3S

Mini-PCIe Socket (for WLAN module) USB + PCIe Interface

Connector location: CN13

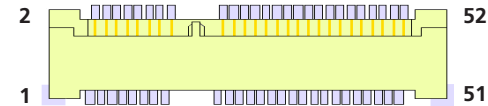

Connector Pin Definition

Pin	Definition	Pin	Definition	Pin	Definition	Pin	Definition
1	WAKE#	2	+V3.3S	27	GND	28	+V1.5S
3	NC	4	GND	29	GND	30	SMB_CLK
5	NC	6	+V1.5S	31	PETn0	32	SMB_DATA
7	CLKREQ#	8	NC	33	PETp0	34	GND
9	GND	10	NC	35	GND	36	USB_D-
11	REFCLK-	12	NC	37	NC	38	USB_D+
13	REFCLK+	14	NC	39	NC	40	GND
15	GND	16	NC	41	NC	42	LED_WWAN#
17	NC	18	GND	43	NC	44	LED_WLAN#
19	NC	20	DISABLE#	45	NC	46	LED_WPAN#
21	GND	22	PERST#	47	NC	48	+V1.5S
23	PERn0	24	+3.3S	49	NC	50	GND
25	PERp0	26	GND	51	NC	52	+V3.3S

SIM Card Connector

Connector location: CN4

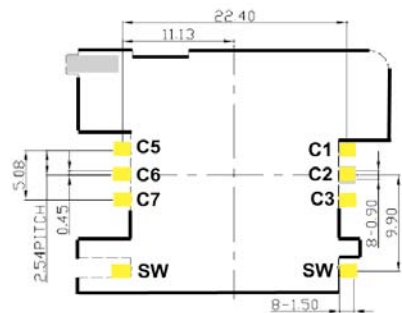

Connector Pin Definition

Pin	Definition	Pin	Definition
C1	POWER VOLTAGE	C2	RESET SIGNAL
C3	CLOCK SIGNAL	C5	GND
C6	VPP:PROGRAM VOLTAGE	C7	I/O
SW	Contact present switch		

Bluetooth Connector

Connector location: J7



Pin	Definition	Pin	Definition
1	GND	2	USB_6P_L
3	USB_6N_L	4	NC
5	NC	6	BT_AUDIO_EN_R
7	NC	8	BT_3.3V
9	NC	10	GND

APPENDIX D: VEHICLE POWER MANAGEMENT SETUP

External Power Output Setting

External +12V and +5V Turn On Simultaneously

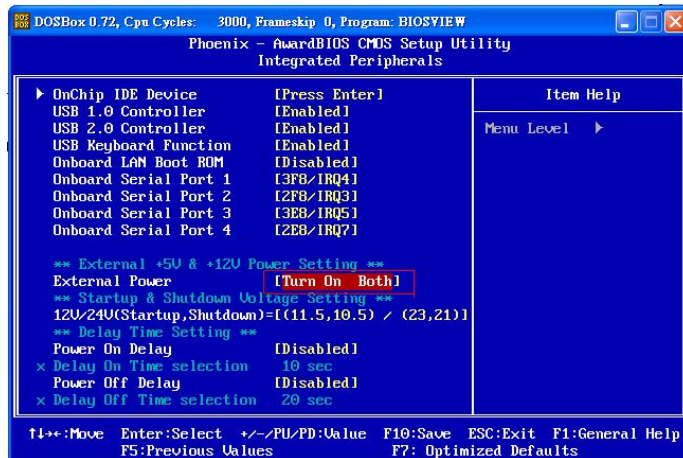

External +12V and +5V Turn Off Simultaneously

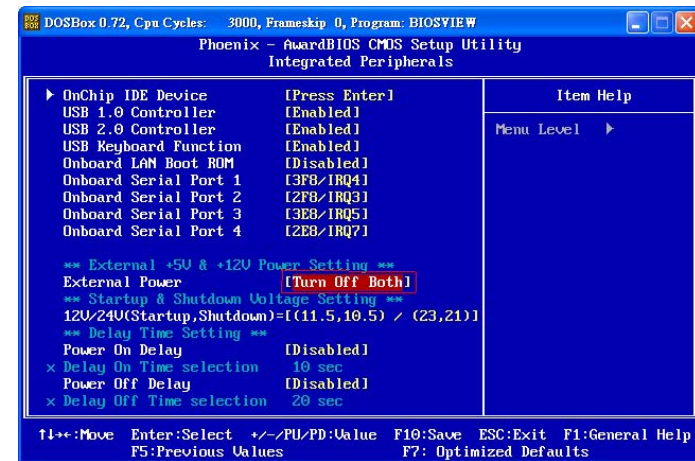

External +12V Turn On Only

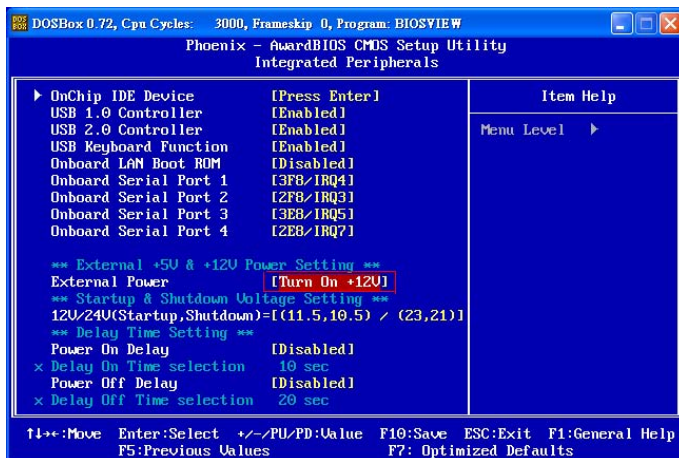

External +5V Turn On Only

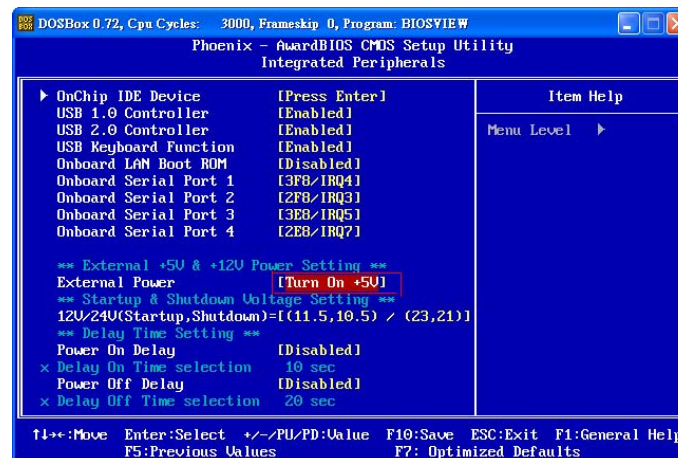

Startup and Shutdown Voltage Setting

1. If the input voltage setting is 12V: set the startup voltage to 11.5V and the shutdown voltage to 10.5V.

If the input voltage setting is 24V: set the startup voltage to 23V and the shutdown voltage to 21V.

If the input voltage setting is 6V~36V, ignore the startup/shutdown setting.

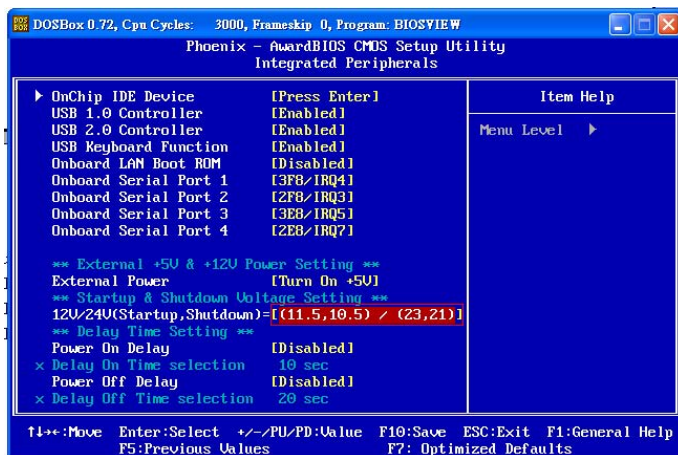

2. If the input voltage setting is 12V: set the startup voltage to 12V and the shutdown voltage to 11V.

If the input voltage setting is 24V: set the startup voltage to 24V and the shutdown voltage to 22V.

If the input voltage setting is 6V~36V, ignore the startup/shutdown setting.

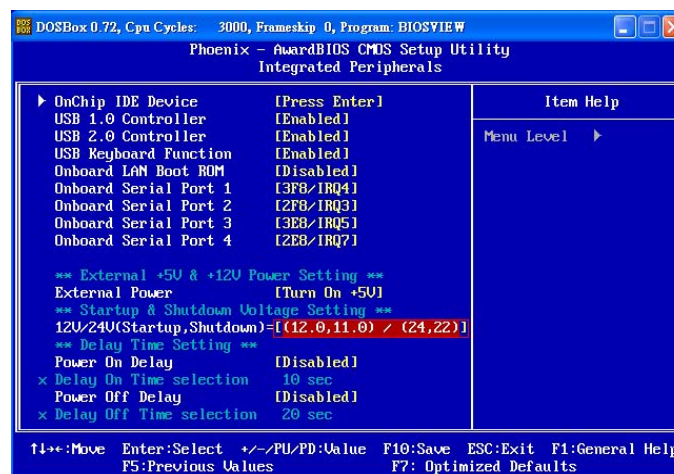

3. If the input voltage setting is 12V: set the startup voltage to 12.5V and the shutdown voltage to 11V.

If the input voltage setting is 24V: set the startup voltage to 25V and the shutdown voltage to 22V.

If the input voltage setting is 6V~36V, ignore the startup/shutdown setting.

4. If the input voltage setting is 12V: set the startup voltage to 12.5V and the shutdown voltage to 11.5V.

If input voltage setting is 24V: set the startup voltage to 25V and the shutdown voltage to 23V.

If the input voltage setting is 6V~36V ignore the startup/shutdown setting.

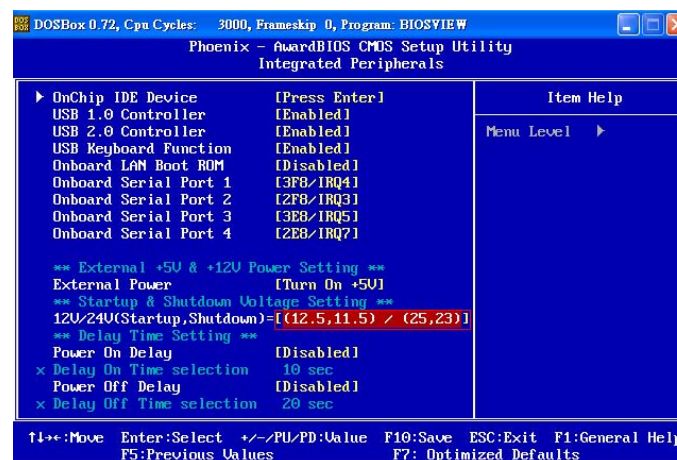
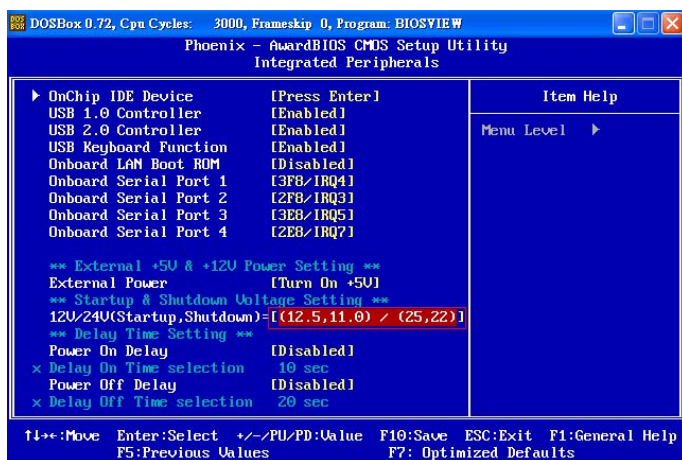

Power-on Delay Setting

Disable Power-on Delay

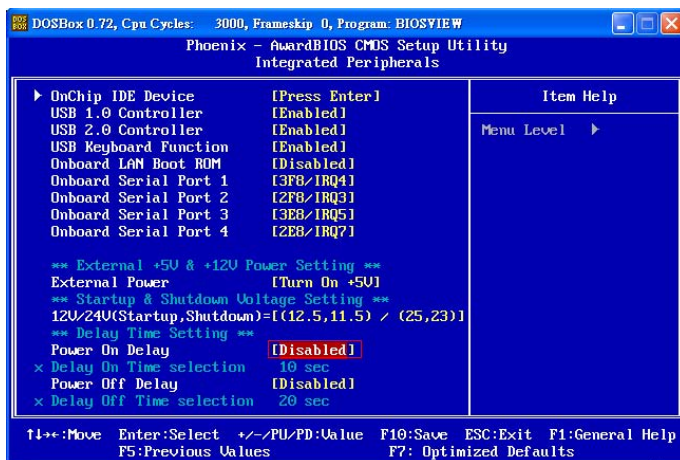

Enable Power-on Delay

Delay time can be set at 10sec/30sec/1min./5min./10min./15min./30min./1 hour.

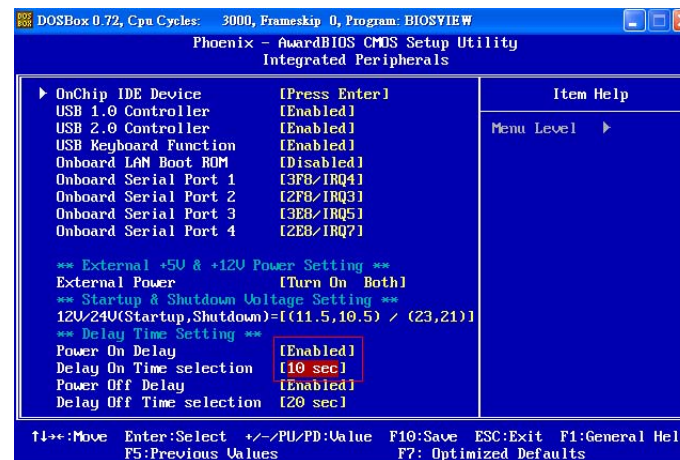

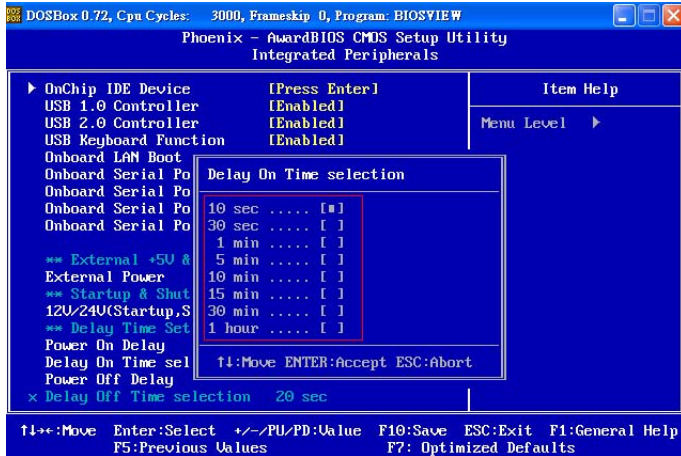

Power-off Delay Setting

Disable Power-off Delay

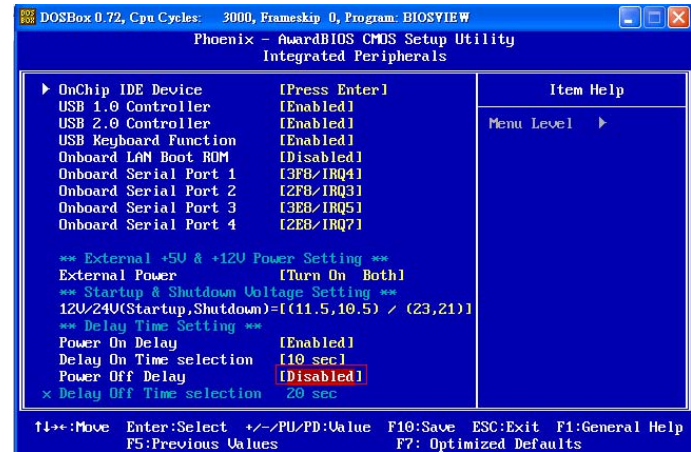

Enable Power-off Delay

Delay time can be set at 20sec/1min./5min./10min./30min./1hour/6hour/18hour.

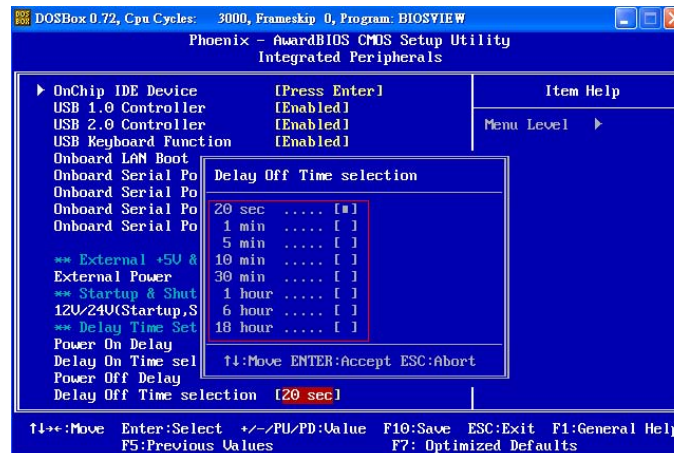
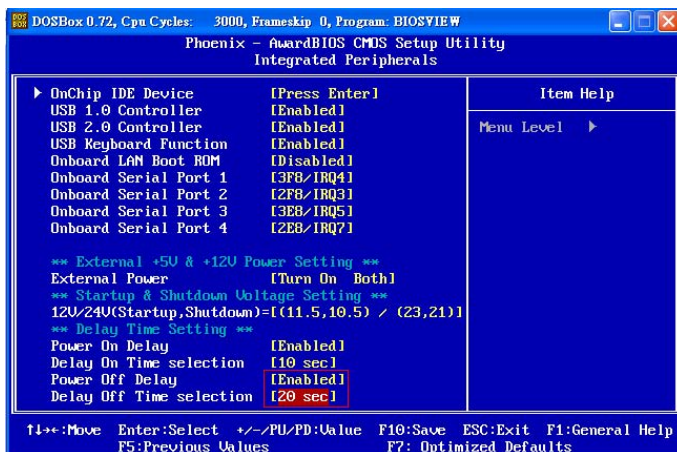

APPENDIX E: POWER CONSUMPTION

OS: XP English

Burn-in Software: Version 5.0

Idle Mode	100% Burn-in Mode	S3	S4	S5
1.47A / 12V	2.76A / 12V	0.11A / 12V	0.01A / 12V	0.01A / 12V

* Device: N/A

For mobile devices without co-location condition (the transmitting antenna is installed or located (more than 20cm away from the body of user and near by person)
FCC RF Radiation Exposure Statement:

1. This Transmitter must not be co-located or operating in conjunction with any other antenna or transmitter.
2. This equipment complies with FCC RF radiation exposure limits set forth for an uncontrolled environment. This equipment should be installed and operated with a minimum distance of 20 centimeters between the radiator and your body.

This equipment has been tested and found to comply with the limits for a Class B digital device, pursuant to part 15 of the FCC rules. These limits are designed to provide reasonable protection against harmful interference in a residential installation. This equipment generates, uses and can radiate radio frequency energy and, if not installed and used in accordance with the instructions, may cause harmful interference to radio communications. However, there is no guarantee that interference will not occur in a particular installation. If this equipment does cause harmful interference to radio or television reception, which can be determined by turning the equipment off and on, the user is encouraged to try to correct the interference by one or more of the following measures:

- Reorient or relocate the receiving antenna.
- Increase the separation between the equipment and receiver.
- Connect the equipment into an outlet on a circuit different from that to which the receiver is connected.
- Consult the dealer or an experienced radio/TV technician for help.

You are cautioned that changes or modifications not expressly approved by the party responsible for compliance could void your authority to operate the equipment.

This device complies with Part 15 of the FCC Rules. Operation is subject to the following two conditions:

- (1) this device may not cause harmful interference and
- (2) this device must accept any interference received, including interference that may cause undesired operation