

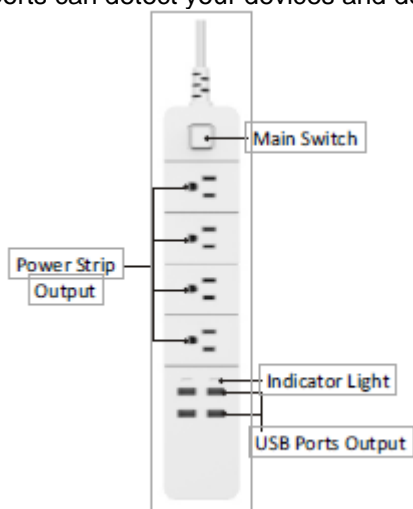

Smart Power Strip
Quick Guide
MODEL NO: NHP-E610

- **Product Overview**

eco4life Smart Power Strip with Surge Protection has 4 power outlets and 4 USB ports. This product works seamlessly with your home automation devices through the eco4life app or voice commands with Amazon Alexa or Google Assistant. It enables wireless control of your lights and devices from anywhere. It automatically switches individual devices on and off based on multiple timers. Intelligent USB charging ports can detect your devices and deliver the ideal charging for optimum safety.



- **Easy Installation**

1. Scan the QR Code or directly download and install the eco4life app from the Apple App Store or Google Play on your smartphone.

App Download



2. Make sure your smartphone is connected to your home Wi-Fi network.

3. Plug the Smart Power Strip into the wall outlet and wait for the red LED light to blink rapidly.

4. If the red light does not blink rapidly, reset the device by pressing the ON/OFF button in five (5) second intervals until red light blinks.

5. From the eco4life app, click + on the upper right corner of the screen to add your device. Select Electrical Outlet and customize settings for your Smart Power Strip. You can rename the individual outlets on the power strip to identify the device plugged in for easier control.

- **ADD DEVICES TO ECO4LIFE APP**

1. Open the "eco4life" app, click "+", select "Electrical outlet", then enter the mobile phone is connected Wi-Fi password configured.

2. Once configured, click on the icon on the upper right corner to customize or restore your settings, check firmware updates and other tasks.



3. From the "Scenes" page click "+" to add scene. Enter the scene name, then add "condition" to perform a single or multiple tasks, collectively with your other smart devices. (See picture 1)
4. From Profile Page, select "Device Sharing", share device control with family members (pic 2)



Picture 1



Picture 2

- **Light Indicators**

Red Light (Blinking):

Sync mode

Red Light (Steady On):

Successfully paired to wireless network Red Light (Off):

Not connected to wireless network Blue Light (On):

Output ports have power

Blue Light (Off):

Output ports have no power

- **Technical Specification**

Disconnection means: Type 1B

Pollution degree:2

Rated Impulse voltage: 1500V

Rated Automation action: 6000 cycles

Input: 125V~, 15A, 60Hz, 1875W

USB input: 100-125V~, 50/60Hz, 0.35A

Output: 5V $\overline{\text{---}}$, 3.1A each, 3.1A total

Wireless Type: Wi-Fi 2.4GHz, IEEE 802.11b/g/n

NOTE: This device supports 2.4 GHz Wi-Fi Network only. It is compatible with Android Version 4.4 -8.0 and iOS Version 8 and above. DO NOT overload capacity.

CAUTION:

Risk of electric shock; Dry location use only, Used indoor only.

Contains Always On Receptacles. To Reduce the Risk of Electric Shock -Disconnect power strip from power source before servicing any equipment connected to the power strip

FCC Statement

This device complies with part 15 of the FCC rules. Operation is subject to the following two conditions: (1) this device may not cause harmful interference, and (2) this device must accept any interference received, including interference that may cause undesired operation.

Changes or modifications not expressly approved by the party responsible for compliance could void the user's authority to operate the equipment.

NOTE: This equipment has been tested and found to comply with the limits for a Class B digital device, pursuant to part 15 of the FCC Rules. These limits are designed to provide reasonable protection against harmful interference in a residential installation. This equipment generates uses and can radiate radio frequency energy and, if not installed and used in accordance with the instructions, may cause harmful interference to radio communications. However, there is no guarantee that interference will not occur in a particular installation. If this equipment does cause harmful interference to radio or television reception, which can be determined by turning the equipment off and on, the user is encouraged to try to correct the interference by one or more of the following measures:

- Reorient or relocate the receiving antenna.
- Increase the separation between the equipment and receiver.
- Connect the equipment into an outlet on a circuit different from that to which the receiver is connected.
- Consult the dealer or an experienced radio/TV technician for help.

RF Exposure Information

This equipment complies with FCC radiation exposure limits set forth for an uncontrolled environment. This equipment should be installed and operated with minimum distance 20cm between the radiator and your body.