

---

# G8D-335A-A

---

## Transmitter, RF Keyless Entry System

< As for the undermentioned product,the amount of SW is different by the same circuit >

【Product No.】	【Function of SW】	【Amount of SW】
G8D-335A-A-NPA	LOCK,UNLOCK, SLIDE DOOR LEFT SLIDE DOOR RIGHT	4SW
G8D-335A-A-NSD	LOCK,UNLOCK, PANIC	3SW
G8D-335A-A-NSP	LOCK,UNLOCK	2SW

Rough sketch

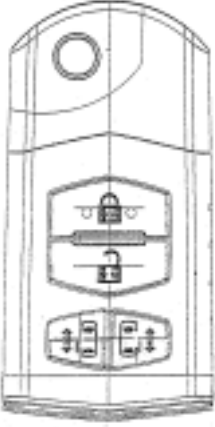
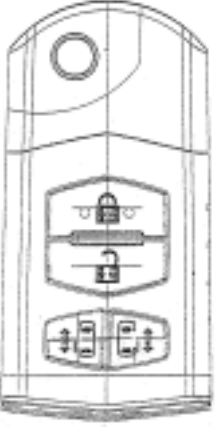
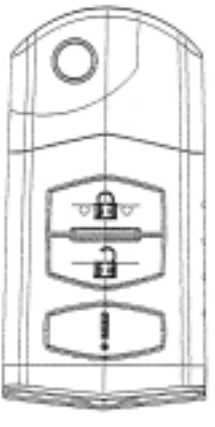
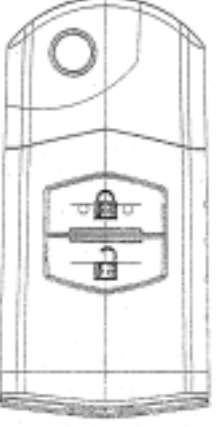
G8D-335A-A	G8D-335A-A-NPA	G8D-335A-A-NSD	G8D-335A-A-NSP
 A rough sketch of a vertical, arched container. It features a circular opening at the top. The interior is divided into three horizontal sections. The top section contains a padlock. The middle section contains a horizontal bar with a padlock. The bottom section contains two smaller padlocks.	 A rough sketch of a vertical, arched container, similar to the first one. It features a circular opening at the top. The interior is divided into three horizontal sections. The top section contains a padlock. The middle section contains a horizontal bar with a padlock. The bottom section contains two smaller padlocks.	 A rough sketch of a vertical, arched container, similar to the first one. It features a circular opening at the top. The interior is divided into three horizontal sections. The top section contains a padlock. The middle section contains a horizontal bar with a padlock. The bottom section contains a single padlock.	 A rough sketch of a vertical, arched container, similar to the first one. It features a circular opening at the top. The interior is divided into three horizontal sections. The top section contains a padlock. The middle section contains a horizontal bar with a padlock. The bottom section contains a single padlock.

# 1. Constitution of the Radio Frequency Keyless Entry System with Door Lock Controller for vehicle

The radio frequency keyless entry is a system that it controls locking and unlocking the door by wireless remote controller. This system consists of two components. The TRANSMITTER is a device that transmits the signal when the button is pressed. The transmission signal consists of several synchronous codes, unique identification code, and security code and function code. The RECEIVER is fixed inside the vehicle. It works intermittently to prevent the battery exhaustion. When the receiver detects the synchronous code, it runs continuously to receive the signals completely. After receiving the signal, the receiver decides which operation will be performed. The user can select the following operations by pressing the button of the remote transmitter.

OPERATION	ACTION
<b>LOCK</b>	Lock the door
<b>UNLOCK</b>	unlock the door (the driver side first, then all doors)
<b>PANIC</b>	The horn is beeped, and the headlight and flasher are blinked
<b>SLIDE DOOR LEFT</b>	Open or close the left slide door.
<b>SLIDE DOOR RIGHT</b>	Open or close the right slide door.

This receiver also controls wired operation. It is available to control the door lock status by using the silicon switch or the remote door control switch (both driver's and passenger's side).

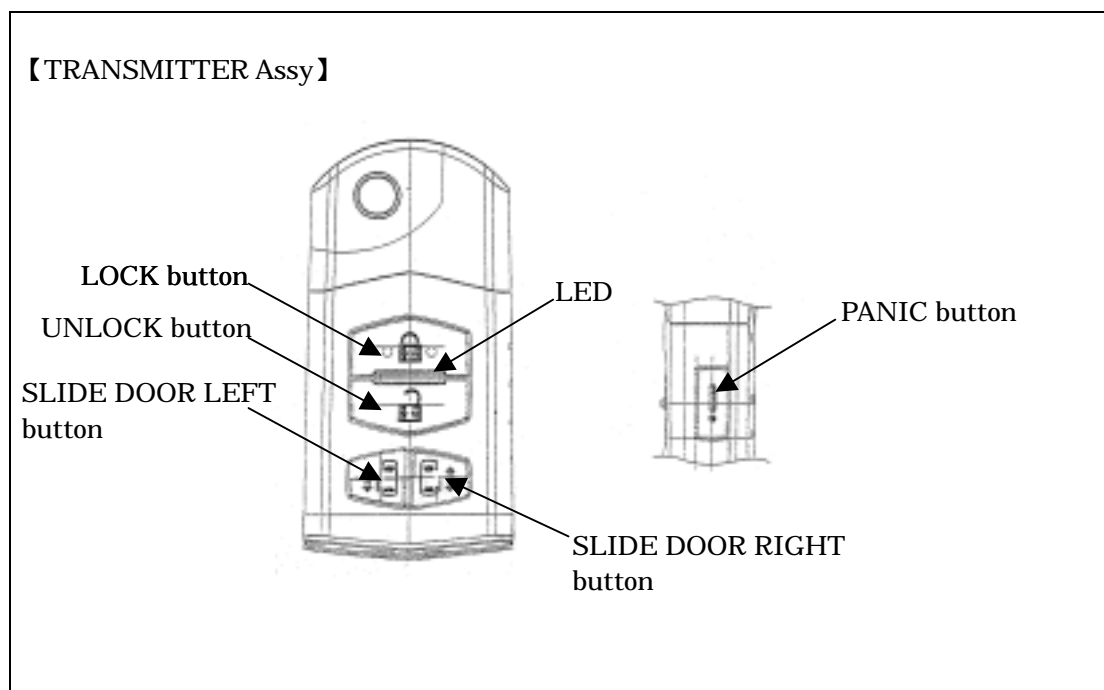

Transmitter  
f =313.85MHz

## 2. User's manual (provisionally)

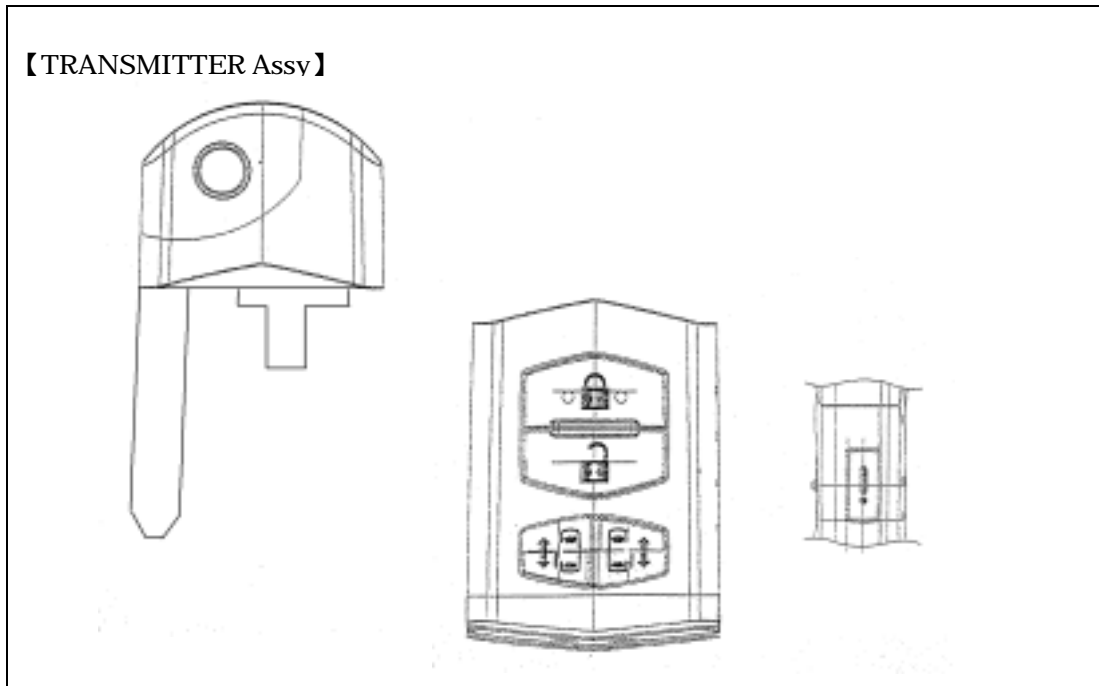

### REMOTE TRANSMITTER

You can lock and unlock your vehicle with the remote transmitter.

#### LOCK

When you push the LOCK button, all the doors will lock.

You cannot lock any of the doors with the remote transmitter if any door is open or the key is in the ignition switch.

#### UNLOCK

When you push the UNLOCK button once, all the doors will unlock. If you unlock the doors with the remote transmitter, but do not open any of the doors within 30 seconds, the doors will automatically relocks.

You cannot unlock any of the doors with the remote transmitter if the key is in the ignition switch.

#### PANIC

Panic mode allows you to remotely sound's horn to attention. To activate this mode, press the PANIC button. Your vehicle's horn will beep for about 150 seconds.

To cancel Panic mode before 150 seconds, press any button on the remote transmitter.

#### SLIDE DOOR LEFT

When you push the SILDE DOOR LEFT button. Open or close the left slide door. To activate this mode, press and hold the SLIDE DOOR LEFT button for about one second.

#### SLIDE DOOR RIGHT

When you push the SILDE DOOR RIGHT button. Open or close the right slide door. To activate this mode, press and hold the SLIDE DOOR RIGHT button for about one second

## ! CAUTION

The remote control switch is a precision electronic device. Therefore, pay attention to the following.

- Do not impose shock on the remote control switch.
- Keep the remote control switch dry.
- Do not disassemble the remote control switch.

Your keyless entry system operates on a radio frequency subject to Federal Communications Commission (FCC) rules and Industry Canada rules.

This device complies with Part 15 of the FCC Rules. Operation is subject to the following two conditions.

- (1) This device may not cause harmful interference, and
- (2) This device must accept any interference received, including interference that may cause undesired operation of the device.

"Complies with RSS-210 of Industry Canada."

## NOTICE

This equipment has been tested and found to comply with the limits for a Class B device, pursuant to part 15 of the FCC Rules. These limits are designed to provide reasonable protection against harmful interference in a residential installation.

This equipment generates, uses and can radiate radio frequency energy and, if not installed and used in accordance with the instruction, may cause harmful interference to radio communications. However, there is no guarantee that interference will not occur in a particular installation. If this equipment does cause harmful interference to radio or television reception, which can be determined by turning the equipment off and on, the user is encouraged to try to correct the interference by one or more of the following measures:

- Reorient or relocate the receiving antenna.
- Increase the separation between the equipment and receiver.
- Connect the equipment into an outlet on a circuit different from that to which the receiver is connected.
- Consult the dealer or an experienced radio/TV technician for help.

## FCC WARNING

Changes or modifications not expressly approved by the party responsible for compliance could void the user's authority to operate the equipment.