

# NOMA PERFORMANCE

*Powerful - Easy to Drive - Cuts Faster - Lawn Looks Better*

335497A

3/01/95

## ALL-WHEEL-STEERING LAWN TRACTOR

Model F4315-000

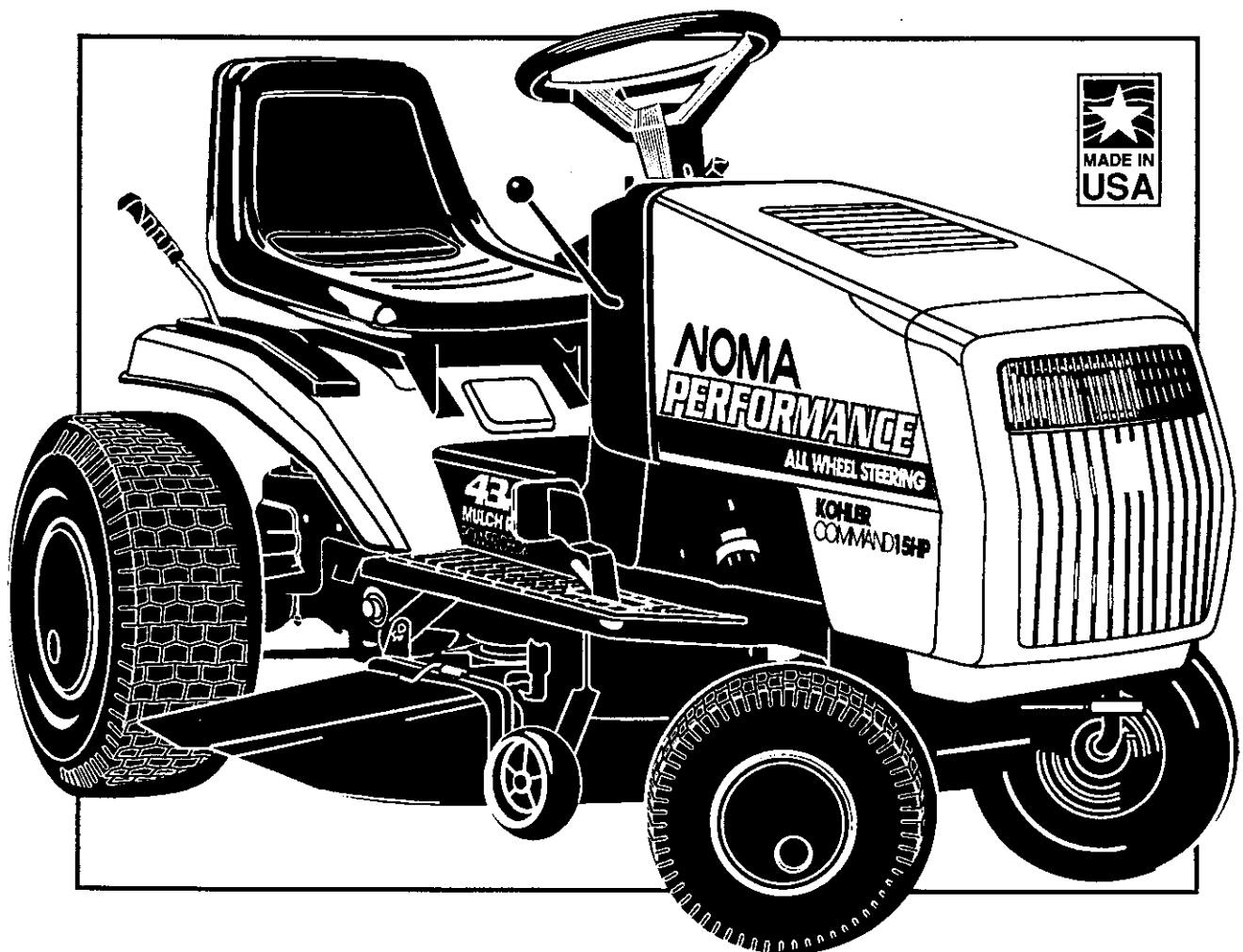

• Safety Rules • Assembly • Operation • Maintenance • Adjustments

**NOTICE!** This unit has a mulching plug installed on the mower deck. To side discharge mow you **MUST** remove the mulching plug. To remove mulching plug see **Mulching Plug Instructions** in the **Maintenance** section of this manual.

---

Dear Customer,

Thank you for your purchase of a **NOMA PERFORMANCE ALL WHEEL STEERING LAWN TRACTOR!**

Your **NOMA PERFORMANCE** lawn tractor is equipped with **All Wheel Steering**. This patented system delivers the increased maneuverability that's essential for cutting a lawn fast and more efficiently. By controlling both the front and rear wheels, **All Wheel Steering** creates a center of turn that is closer to the mowing deck. The result is a tight 13.5-inch mowing radius that allows you to cut around trees. You can also make sharp turns without backing up, mow difficult to cut areas, and maneuver for close trimming. With **All Wheel Steering**, you spend much less time mowing your lawn and much more time pursuing your leisure time activities.

This manual contains instructions for safety, assembly, operation, maintenance, adjustments and storage. Read this manual carefully and completely so that you will know proper assembly, use and care for your unit.

Be sure to fill in and mail the registration card packed with the unit. This information will prove valuable for any future service and product updates.

For product service not covered in this manual, contact an authorized service dealer. A list of authorized parts distributors has been included in the **Repair Parts** manual. A nationwide parts and service organization has been established to provide locally available parts and service.

Again, Murray Outdoor Products thanks you for the decision to purchase a quality, American made product, the **NOMA PERFORMANCE ALL WHEEL STEERING LAWN TRACTOR**. All of us at Murray Outdoor Products are dedicated to providing high quality products that meet your needs.

Sincerely,

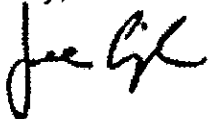

Joe Cunningham  
Product Manager

# TABLE OF CONTENTS

|                                   |       |                             |       |
|-----------------------------------|-------|-----------------------------|-------|
| INTERNATIONAL SYMBOLS .....       | 4     | MAINTAINANCE .....          | 18-24 |
| OWNER'S INFORMATION .....         | 5     | ADJUSTMENTS .....           | 25-28 |
| RESPONSIBILITY OF THE OWNER ..... | 5     | TROUBLESHOOTING GUIDE ..... | 29-30 |
| SAFETY RULES .....                | 5-6   | STORAGE .....               | 31    |
| SAFE MOWING GUIDE .....           | 7-9   | SLOPE GUIDE .....           | 32    |
| STEPS TO FOLLOW .....             | 10    | NOTES .....                 | 33-35 |
| ASSEMBLY .....                    | 11-12 | WARRANTY .....              | 36    |
| OPERATION .....                   | 13-17 |                             |       |

## NOTE

Some tractor models may require different instructions for assembly and/or repair than shown in this manual. The **Repair Parts** manual (supplied with tractor) will contain these instructions if required on your model.



This lawn tractor is equipped with an internal combustion engine and should not be used on or near any unimproved forest-covered, brush-covered, or grass-covered land unless the engine's exhaust system is equipped with a spark arrester meeting applicable local or state laws (if any). If a spark arrester is used, it should be maintained in effective working order by the operator.































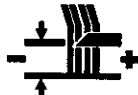



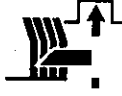













In the State of California the above is required by law (Section 4442 of the California Public Resources Code). Other states may have similar laws. Federal laws apply on federal lands. A spark arrester for the muffler is available through an Authorized Service Center

References throughout this manual concerning the right or left side are determined as you face forward while seated in operator's seat.

Photographs and illustrations in this manual may not show your model but are for reference. They are based on the latest information.

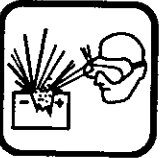
# INTERNATIONAL SYMBOLS

**IMPORTANT!** These symbols may appear on your unit or in literature supplied with the product. Learn and understand their meaning.

|  |   |   |   |   |   |   |   |
|--|---|---|---|---|---|---|---|
|   |    |    |    |      |     |    |    |
| ENGINE START   | ENGINE RUN  | ENGINE STOP   | OFF   | ON  | FAST  | SLOW  | CHOKE   |
|    |    |    |    |      |     |    |    |
| OIL PRESSURE   | FUEL  | BATTERY   | LIGHTS/ LIGHTS ON   | LIGHTS OFF  | HOUR METER  | ALL-SYSTEMS-GO  | NEUTRAL   |
|   |    |    |    |      |     |    |    |
| FORWARD  | REVERSE   | CLUTCH  | BRAKE   | PARKING BRAKE   | MOWER HEIGHT  | MOWER CUTTING HEIGHT RAISE  | MOWER CUTTING HEIGHT LOWER  |
|    |    |    |    |      |     |    |    |
| MOWER BLADE CLUTCH   | MOWER BLADE ENGAGE  | MOWER BLADE DISENGAGE   | ARROW   | INCREASE  | DECREASE  | CLUTCH  | MOWER   |
|  |   |   |  |    |    |  |  |
| BRAKE OFF  | BRAKE ON  | PARKING BRAKE   | CAUTION   | DANGER! KEEP HANDS AND FEET AWAY  | DANGER! KEEP HANDS AND FEET AWAY  | DO NOT USE THIS AREA AS A STEP  | REMOVE SPARK PLUG   |
|  |  |  |  |  |  |   |   |
| DO NOT MOW WHEN CHILDREN & OTHERS ARE AROUND                                       | GO UP AND DOWN SLOPES, NOT ACROSS.  | KEEP BYSTANDERS AWAY  | BEWARE OF THROWN OBJECTS  | READ OWNER'S/ OPERATOR'S MANUAL   | HOT SURFACE   |   |   |
|  |  |  |  |   |   |   |   |
| SHIELD EYES EXPLOSIVE GASES CAN CAUSE BLINDNESS OR INJURY                          | NO SPARKS, FLAMES, OR SMOKING   | SULFURIC ACID CAN CAUSE BLINDNESS OR SEVERE BURNS                                   | FLUSH EYES IMMEDIATELY WITH WATER. GET MEDICAL HELP FAST                            |   |   |   |   |

# OWNER'S INFORMATION

This Owner's/Operator's Manual is for several different models. The instructions are written for a person with some mechanical ability. Like most service books, not all the steps are described. Steps on how to loosen or tighten fasteners are steps anyone can follow with some mechanical ability. Read and follow these instructions before you use the unit.

**Know your product:** If you understand the unit and how the unit operates, you will get the best performance. As you read this manual, compare the illustrations to the unit. Learn the location and the function of the controls. To help prevent an accident, follow the operating instructions and the safety rules. Keep this manual for future reference.

**IMPORTANT:** Many units are not assembled and are sold in cartons. It is the responsibility of the owner to make sure the assembly instructions in this manual are exactly followed. Other units are purchased in an assembled condition. On assembled units, it is the responsibility of the owner to make sure the unit is correctly assembled. The owner must carefully check the unit according to the instructions in this manual before it is first used.

## RESPONSIBILITY OF THE OWNER

The responsibility of the owner is to follow the instructions below.

1. Carefully read and follow the rules for safe operation.
2. Follow all the assembly instructions.
3. Inspect the unit.
4. Make sure the operator of the unit knows how to correctly use all standard and accessory equipment.
5. Operate the unit only with guards, shields, and other safety items in place and working correctly.
6. Correctly adjust the unit.
7. Service the unit only with authorized or approved replacement parts.
8. Complete all maintenance on the unit.

### Environmental Awareness

- Do not fill the engine's fuel tank completely full.
- Drain fuel for off-season storage.
- Use only unleaded gasoline.
- Service the air cleaner regularly.
- Change oil regularly. Use 30W oil in summer.
- Tune-up the engine regularly.
- Keep equipment in efficient operating condition.
- Dispose of used engine oil properly.

## SAFETY RULES



### Safe Operation Practices for Riding Vehicles

As Recommended by American National Standards Institute

**WARNING:** This cutting machine is capable of amputating hands and feet and throwing objects. Failure to observe the following safety instructions could result in serious injury or death to the operator or bystanders.

### GENERAL OPERATION:

1. Read, understand and follow all instructions in the Owner's/Operator's Manual, on the machine, the engine and with any attachments before starting.
2. Only allow responsible adults familiar with the instructions to operate the machine.
3. Clear the area of objects such as rocks, toys, wire, etc. which could be picked up and thrown by the blade.
4. Be sure the area is clear of other people before mowing. Stop the machine if anyone enters the area.
5. Never carry passengers.
6. Disengage power to the mower or any attachments before backing up. Do not mow in reverse unless absolutely necessary. Always look down and behind before and while backing.
7. Be aware of the direction the mower discharges. Do not point discharge from the mower at anyone or at places where people may be. Do not operate the mower without either the entire grass bagger or the mower guard in place.
8. Slow down before turning.
9. Never leave a machine unattended with the engine running. Always disengage the blade(s), set the parking brake, stop the engine and remove the key before dismounting.
10. Disengage power to attachment(s) when transporting or not in use. Disengage the blade(s) when not mowing.
11. Stop the engine before removing the grass bagger or unclogging the chute.
12. Mow only in daylight or good artificial light.
13. Do not operate the machine while under the influence of alcohol or drugs or when very tired.
14. Watch for traffic when operating near or crossing roadways.
15. Use extra caution when loading or unloading the machine when using a trailer or truck for transporting.
16. Disengage all attachment clutches and shift into Neutral before attempting to start the engine. (on gear drive models)
17. Disengage all attachment clutches before attempting to start the engine. (on hydro models)
18. Always wear safety glasses or an eye shield when you operate the unit to protect your eyes from foreign objects that can be thrown from the unit. Always wear eye protection when you make an adjustment or repair to the machine.
19. Use care when pulling loads or using heavy equipment.
  - a. Use only approved drawbar hitch points.
  - b. Limit loads to those you can safely control.
  - c. Do not turn sharply. Use care when backing.
  - d. Use counterweights when suggested in the Owner's/Operator's Manual.

## SLOPE OPERATION:

Slopes and rough terrain are major factors related to loss of control and tip over accidents which can result in severe injury or death. **ALL slopes require extra caution. If you cannot back up the slope or if you feel uneasy on the slope, do not mow it. See the " Slope Guide" in the back of this book to check for safe operation.**

### DO

1. Mow up and down slopes, not across.
2. Remove obstacles such as rocks, limbs, etc...
3. Watch for holes, ruts or bumps. Uneven terrain could overturn the machine. "Tall grass can hide obstacles."
4. Use slow speed. Choose a low enough gear so that you will not have to stop or shift while on the slope. (on gear drive models)
5. Use slow speed on slopes. Do not make sudden speed changes. (on hydro models)
6. Follow the manufacturer's recommendations for wheel weights or counterweights to improve stability.
7. Use extra care with grass baggers or other attachments, they can change the stability of the machine.
8. Keep all movement on the slopes **slow and gradual**. Do not make sudden changes in speed or direction.
9. Avoid starting or stopping on a slope. If tires lose traction, disengage the blades and proceed slowly **straight down** the slope.

### DO NOT

1. **Do not** turn on slopes unless absolutely necessary, then only turn slowly and gradually downhill, if possible.
2. **Do not** mow near drop-offs, ditches or embankments. A wheel over the edge or an edge caving in could cause a sudden overturn and an injury or death.
3. **Do not** mow on wet grass. Reduced traction could cause sliding.
4. **Do not** try to stabilize the machine by putting your foot on the ground.
5. **Do not** use a grass catcher or other rear mounted accessories on steep slopes (greater than 10 degrees).

## CHILDREN:

**Tragic accidents can occur if the operator is not alert to the presence of children. Children are often attracted to the machine and the mowing activity. NEVER assume that children will remain where you last saw them.**

1. Keep children out of the mowing area and in the watchful care of an adult other than the operator.
2. Be alert and turn the engine off if children enter the area.
3. Before and when backing, look **behind and down** for small children.
4. Never carry children or any passengers. They may fall off and be seriously injured or interfere with the safe operation of the machine.
5. Never allow children to operate the machine. Instruct children in the dangers of the machine.
6. Use extra care when approaching blind corners, shrubs, trees or other objects that may obscure vision.

## SERVICE:

1. Use extra care when handling gasoline and other fuels. Fuels are flammable and the vapors are explosive.
  - a. Use only an approved container.
  - b. Never remove the gas cap or add fuel with the engine running. Allow the engine to cool for several minutes before refueling. Do not smoke.
  - c. Never refuel the machine indoors.
  - d. Never store the machine with fuel in the tank or fuel container inside where there is an open flame, such as a water heater.
2. Never start or run the engine inside a closed area.
3. Keep all nuts and bolts, especially the blade attachment nuts tight. Frequently check the blade(s) for wear or damage such as cracks and nicks. A blade that is bent or damaged must be immediately replaced with an original equipment blade(s) from an authorized service dealer. For safety, replace the blade(s) every two years. Keep the equipment in good condition.
4. Never tamper with the safety devices. Check their proper operation regularly.
5. To reduce fire hazards keep the machine free of grass, leaves or other debris build-up. Clean up oil or fuel spills. Allow the machine to cool before storing.
6. Stop and inspect the equipment if you strike an object. Repair, if necessary, before restarting.
7. Never make adjustments or repairs with the engine running. The carburetor can be adjusted with the engine running. Do not change the engine governor settings or over-speed the engine.
8. Grass bagger components are subject to wear, damage and deterioration, which could expose moving parts or allow objects to be thrown. For storage, always make sure the grass bag is empty. Frequently check components and replace with manufacturer's recommended parts when necessary.
9. Mower blade(s) are sharp and can cut. Wrap the blade(s) or wear gloves and use extra caution when servicing them or the mower deck area.
10. Check the brake operation frequently. Adjust and service as required.
11. Wait for all movement to stop before servicing any part of the unit.



**Look for this symbol to indicate important safety precautions. This symbol indicates: "Attention! Become Alert" Your Safety Is At Risk."**

# SAFE MOWING GUIDE

Each person that operates power equipment must learn to use correct and safe mowing procedures. **To help you learn, carefully read the following pages.** Most of the time the operator was not correctly shown or did not read the instructions on the unit or in the Owner's/Operator's Manual before using the unit. Also, some operators do not have enough experience. The result is unsafe use, endangering the operator, bystanders and the equipment. Another result can be a poor appearance of the area mowed.

**Read this book.** Read the instructions on the unit. Operate the mower according to the Safe Mowing Guide. Follow all safety rules, cautions or warnings in this book and on the unit. Make sure anyone that uses the unit reads the instructions and is told how to safely operate the mower.

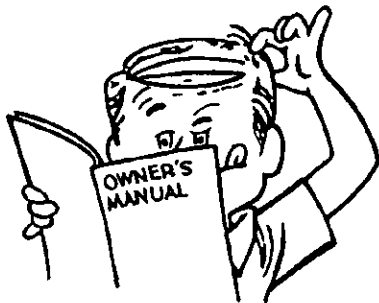

The mower will give you good service and durability, if operated in normal conditions. If the mower is not correctly serviced or is used where the terrain is rough or unsuitable, product performance and safety will be decreased.

Correct clothing is an important part of safe mowing. Safety glasses will protect the eyes from objects discharged by the mower. Safety shoes with steel plates can protect a foot from injury by the blade. For protection from objects discharged from the mower, wear clothing that will cover the arms and legs.

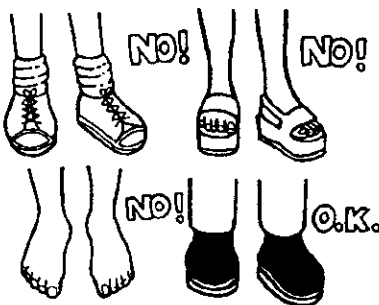

Before you start cutting the grass, practice using the mower in a large open and level area. Learn the location of the controls on the mower. Know the purpose of the controls and how they work. In an emer-

gency, how fast you can stop the blade is important. Learn how to control the mower at all times.

Many engines are started by hand. When you use a pull start or rope start, place your feet apart and away from the blade(s). Hold the rope handle tight. Never wrap the rope around your arm or fingers for a "Better grip". To start the engine, follow the instructions on the mower, in this book and in the engine operating instructions.

For electric start engines, sit in the seat to start the engine. The battery can be dangerous. Follow the instructions on the battery, the acid container, and in this book when working with the battery. Even small batteries have enough voltage to cause an injury. Always be careful.

The mower is designed to be operated by one person. Never let another person ride with you on the unit or on any accessories. A passenger will make the unit harder to control, block the visibility or distract the operator and is dangerous to the operator, the passenger and the equipment. Without a passenger seat, the passenger can fall from the mower or contact dangerous parts. A mower is not a toy for showing off or for giving rides.

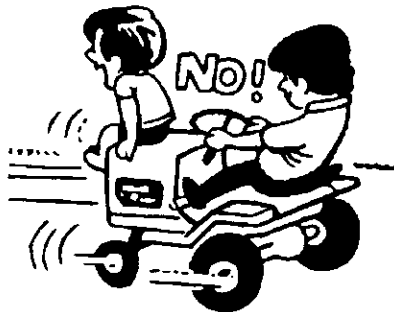

Never cut a wet lawn. Wet grass can cause an accident, affect mower performance and can cause problems with future lawn growth and appearance. Wet grass is slippery and can cause the mower to slip. Someone can get injured by touching the blade(s). Wet grass tends to clog the mower, causing poor discharge. Cut wet grass will collect on the lawn, retarding the growth of the grass. Also, getting the mower wet will cause parts to rust and decrease the life of the unit.

When you look over the lawn, remember obstacles that cannot be removed, like pipes, stumps or rocks. Keep away from these obstacles that can cause damage to the mower or injury to the operator or a person near the mower. Clear the area of rocks, toys, wire or other loose objects. These items can damage the mower or can be discharged by the mower blade.



The blade of power mower rotates very fast. It can discharge rocks and other objects over a long distance which can be dangerous. The force of the objects can break windows, cause injuries or even put an eye out. Most of the time the injury is to a person, like a child. Keep every person completely away from the area to be mowed. Make sure the grass is not discharged toward anyone. Planning your mowing pattern has a double advantage. It can decrease the possibility of an injury and make the clean up after mowing easier.



Check the terrain of the area to be mowed. Mow in pattern that will keep you away from dangerous areas. Check the distance you need to stop and the distance available to turn. Slopes and rough terrain must be mowed carefully and some areas must not be mowed at all. With riding mowers, mow up and down the hill. When you must mow rough terrain or on slopes, never change directions or change speeds and stop in these areas only in an emergency.

Before you ride up or down a slope, try to back straight up the slope. Do not ride up or down a slope that is too steep to back straight up. See the "Guide" in the back of this Owner's/Operator's Manual to check any slopes.

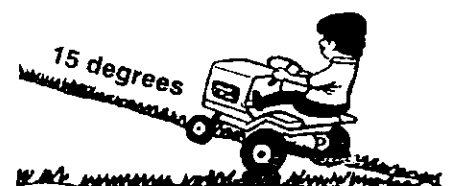

# SAFE MOWING GUIDE

Before you start cutting, make sure the mower was completely assembled according to the Owner's/Operator's Manual. If the mower was completely assembled at the store, you must still check the mower according to the assembly instructions. Make sure the mower is correctly assembled and that all fasteners are tight. Make sure the engine has the correct amount of oil. Check these items often during the life of the mower.

Your mower has a gasoline engine. Gasoline is a dangerous fuel. Keep gasoline only in an approved safety gasoline container. Do not keep large amounts of gasoline. When you add gasoline to the fuel tank, do not smoke. Store the gasoline container and the mower in an area that has good ventilation. Also, keep the gasoline away from any flames like the pilot light of a furnace or any other source of ignition. If the mower is to be stored for more than a few weeks, remove the gasoline from the fuel tank. When inside an enclosure, do not add gasoline to the fuel tank. Before you add gasoline move the mower outside and add gasoline carefully. Before you start the engine, remove any gasoline from the outside of the fuel tank or from the mower. Warm gasoline will expand. Leave some space in the fuel tank for the gasoline to expand. Also, the fuel cap has a vent hole for fuel vapors. Always use the correct fuel cap. Failure to follow safety rules about gasoline will cause fires and explosions, injury to you and damage to the equipment and other property.

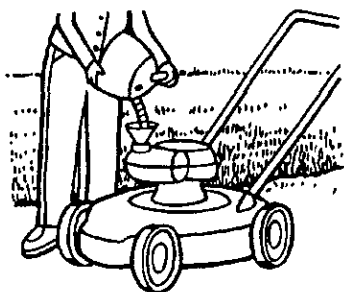

If you add gasoline to an engine that is running or hot, the result can be an explosion. Before you add gasoline, stop the engine and let the engine cool for several seconds. Remove dry grass and other debris from the mower. Keep the mower clean to improve the performance, help the engine and transmission run cooler, extend the life of moving parts, and decrease the danger of a fire.

Fires and explosions are not the only dangers when working around a mower. The engine, transmission, and the muffler will get hot in several minutes when the engine

is running. Do not touch these parts of the mower. Stop the engine. Let the engine and transmission cool before servicing the mower. Remember, exhaust fumes are dangerous. Never operate the engine inside a building.

When you get a new mower, it can be a new experience for the family. Tell each person how a mower can be dangerous. Remember, a mower is not a toy. A mower is not to be used by children or anyone not old enough, strong enough or that does not have experience.

If the mower is not correctly assembled, not operated correctly, or not regularly serviced, the mower can be dangerous. The most important rule to follow is always use good judgement and common sense. Mow safely and carefully.

Your mower will easily cut thick grass. Fingers, feet and other parts can also be cut by the blade. Injuries occur when the operator does not think and reaches into the chute opening. Always operate the mower as if the blade is rotating. Do not service or make an adjustment, except to the carburetor, while the engine is running.

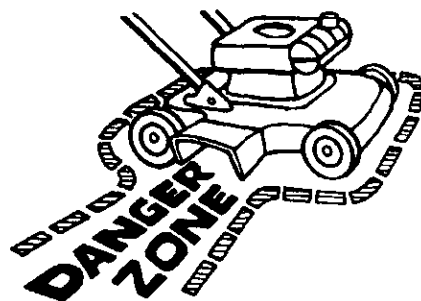

Use only accessories that are factory approved for your mower. The wrong accessory can decrease the safety of the mower and can even damage the unit. Read and follow the instructions included with the accessory and the mower.

Use only original equipment or replacement parts that are factory approved for service. If you need service, select an Authorized Service Center for your mower. If you do the work on the unit, follow the instructions in the Owner's/Operator's Manual.

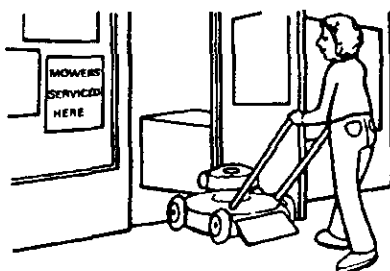

When you mow, remember that children are attracted to the mower. Always use caution when mowing around obstacles like trees or shrubs or when moving backward. Only mow in a forward direction if possible. Your visibility is decreased when you mow backward. Also, the blades are made to cut while the unit is moving forward. If you mow backward, the cutting performance decreases.

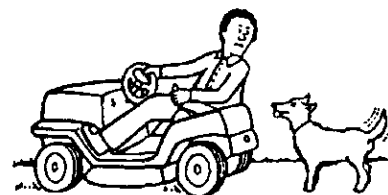

Before you leave the mower, stop the engine. Remove the key. Disengage and lower any attachment. Set the parking brake. Never mount or dismount from the seat while the engine is running. An accident can occur if you touch the brake, shift lever, throttle, clutch, or mower clutch lever while the engine is running. Mount and dismount from the seat on the side opposite the discharge chute.

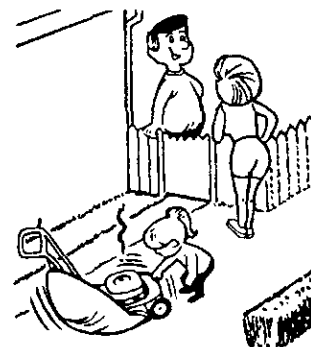

Make sure you are in good condition when you mow. When you mow for several hours your reflexes will decrease and your mind will not be as alert. Take a short break or an accident can occur. If the temperature is hot, use caution to prevent dehydration. If you are tired, angry or not completely alert, do not operate the mower. If you use alcohol, medication or drugs, do not use the mower or any type of power equipment.

Engine speed is a key to safe mowing and to a good looking lawn. The maximum speed of the engine was set at the factory. Do not change the setting of the engine governor.

Select the maximum engine and ground speed that is right for the terrain and the height of the grass. The blade cuts best when the engine is operating at maximum



# SAFE MOWING GUIDE

speed. Also, the grass catcher will function better when the engine is operating at maximum speed. On slopes, decrease the ground speed and use care making sure mower feels safe to operate.

If the weather conditions are bad, do not mow. If weather conditions become bad, stop cutting and finish later. It is dangerous to cut grass in the rain. Always find protection in an electrical storm. If the weather conditions are extra dry, protect your eyes with safety glasses from the dust and from the objects discharged by the mower. Also, a dust or a pollen mask can help.

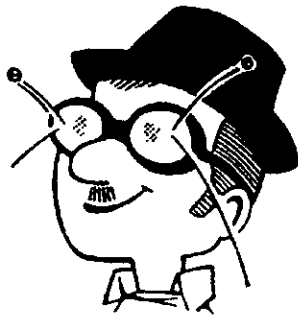

Your mower is equipped with a number of safety devices which are important to the safety of the operator and bystanders and must never be changed or removed from the mower. If a safety device is lost, damaged or no longer functions, repair or replace the device before you operate the mower.

It is best to mow during the day. If you must mow at night, make sure there is enough light for safe operation.

Your mower will require regular maintenance and service. The maintenance schedule depends on the hours of use. Also, mowing conditions can change the schedule. Check the Owner's/Operator's Manual for more information. Correct maintenance will help the mower function safely.

Do not service the mower (except for the carburetor adjustment) while the engine is running. Before you service the unit, even with the engine stopped, always disconnect the wire from the spark plug to prevent the engine from starting.



If you hit a large object during operation, stop the engine. Remove the wire from the spark plug. Carefully inspect the mower for damage. Before you start the engine again, make the necessary repairs. If you feel new or excessive vibration, immediately stop the engine and check for the problem.

Vibration can be a warning of a problem. Keep all nuts, bolts and screws tight.

The blade is the most dangerous part of the mower. Frequently check the blade and the blade mounting fasteners. Keep the fasteners tight. If the blade hits a solid object, stop the engine. Remove the wire from the spark plug. Check for a blade that is bent, cracked or for other damages. Before you start the engine, replace the damaged blade. For safety, replace the blade every two years.

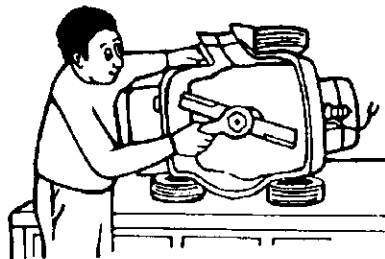

A sharp blade decreases the work load on the engine and more evenly cuts grass. Frequently sharpen the blade for a better looking cut. Use the left side of the mower deck to trim near an object.

A grass catcher is a good accessory for your mower. For best performance and safety, make sure the grass catcher is approved for use with your mower. Follow the assembly and operation instructions included with the grass catcher.

Some grass catchers require a special blade for best performance. Before you attach, check, or empty the grass catcher, always stop the engine. Before each use of the grass catcher, check for cracks, wear or deterioration. Before you use the grass catcher, replace a damaged part with a replacement part approved by the factory.



For you to have a good green lawn, follow the mowing procedures below. Do not cut the grass too short. If you cut the grass too short you can cause the grass to become yellow or make the lawn look brown. Use a lower height of cut in cool months when the grass is thicker. Raise the height of cut in hot dry periods. If you cut the grass with

a blade that is not sharp or at a slow engine speed you can damage the grass. Move the throttle control to the FAST position when mowing and using the grass catcher. Also, use a slower ground speed when using the grass catcher.

If you change the direction or pattern of cut slightly every time you mow will make the grass grow stronger and thicker. Do not add oil or gasoline to the mower while on the lawn. Spilled oil or gasoline can kill the grass. In high or thick grass, do not try to cut all the grass the first time. Raise the height of cut on the first cutting and lower the height for the next cutting. Another way is to cut only part of the width of the mower and decrease your ground speed (not the engine) to move more slowly so that the mower can discharge the grass as it moves forward.

Understand the controls and how they work. Learn the ground speed(s) of your mower. Check the stopping distance required at different travel speeds. Check the turning radius of the mower. The controls on your riding mower are different from an automobile. The throttle is operated by hand and holds the engine speed constant until it is changed. The location of the shift lever and the shift pattern is different from that of an automobile. Also, the brake and clutch systems are different. Remember the procedures to follow in an emergency. Remember, turning off the ignition switch will stop the blade and the drive mechanism. If the traction of the wheels is lost or does not feel safe, disengage all systems and stop the engine. Dismount from the mower. Push the unit to a safe place before you begin mowing again.

Your unit has an electrical system that includes an seat switch in the seat. The seat switch detects if the operator is sitting on the seat. The engine will stop if the operator leaves the seat when the blade engagement control is engaged. This seat switch is a safety device only. It must not regularly be used to stop the engine or the blade. There are other control systems on the mower for this purpose. Always keep the seat switch and other safety devices and controls in place and operating for your protection.

Remember, your mower is a tool that can be dangerous if it is not correctly used. Follow the instructions in this Owner's/Operator's Manual. Safe and careful use of the mower will give you many safe hours of problem free use.

# STEPS TO FOLLOW

## BEFORE MOWING

- Be sure to dress correctly. Wear hard shoes, not sandals or tennis shoes.
- Examine the blade. A blade that is bent, cracked or damaged must be replaced with a factory replacement blade.
- Fill the fuel tank outside. Clean off spilled fuel.
- Read and follow the Owner's/Operator's Manual, the instructions with the engine, and the instructions with any attachments. Owner's/Operator's Manual instructions are for your safety and the safety of others.
- Exhaust fumes are dangerous. Start the engine outside.
- Make sure all safety devices are in place and working correctly.
- Operation of the mower is only for a person that has experience.
- Wet grass can be dangerous. Let the grass dry.
- Instruct children and others to keep away from the work area.
- Never cut the grass without good light.
- Pick up loose objects. Remove them from the mowing area.

## WHILE MOWING

- Watch for fixed objects and avoid them. They can damage the mower or cause injury.
- A hot engine, muffler, and transmission will cause a burn. Do not touch.
- Inclines and slopes must be carefully mowed. See the "Guide" in the back of this book to check a slope.
- Lack of daylight or good artificial light is cause to stop mowing.
- Examine the mower, the blade, and other parts for damage after hitting a foreign object or if the unit vibrates excessively.
- Do not make adjustments or repairs without stopping the engine (except for carburetor). Disconnect the spark plug wire.
- On or near roads, watch out for traffic. Direct discharge away from roads.
- When mowing, avoid areas where traction is unsure. Look back before changing direction of travel.
- In heavy grass, raise the cutting height. Cut slower. Stop the engine to remove clogged grass from the mower.
- Never remove any safety related parts.
- Do not pour gasoline into a engine that is hot or running.

## AFTER MOWING

- Always let the mower cool before storing in an enclosed area.
- Foreign material on the mower is dangerous. Clean off grass, leaves, grease, and oil before storing.
- Tighten all loose nuts, bolts, and screws before you use the unit.
- Empty and clean any grass catcher or other accessory.
- Remove the key or disconnect the spark plug wire to prevent unauthorized use.
- Make sure the mower is not kept near a source of ignition. Gas fumes can cause an explosion.
- Only original parts or factory approved substitutes can be used to service the mower.
- When storing the mower for an extended period, remove the fuel from the fuel tank.
- Instruct children to leave the mower alone. It is not a toy.
- Never keep gasoline near a source of ignition. Always use an approved container. Keep gasoline away from children.
- Lubricate according to the Owner's/Operator's Manual. See "Lubrication".

**IMPORTANT- READ THE OWNER'S/OPERATOR'S MANUAL. KEEP THIS BOOK FOR FUTURE USE AND REFERENCE.**



**WARNING: Look for this symbol to point out important safety precautions. It means: "Attention! Become Alert! Your Safety Is Involved."**

Your lawn tractor has a right side and left side as you face forward while seated in operator's seat.

## TO ACTIVATE BATTERY

**IMPORTANT:** : Before you attach the battery cables to the battery, check the battery date code. The battery date code tells if the battery must be charged.

1. Check the battery date code on top of the battery.
2. If the battery is put into service before the battery date, the battery cables can be attached without charging the battery. See **Battery Installation** paragraph in **Maintenance** section of this manual.
3. If the battery is put into service after the battery date, the battery must be charged. To charge proceed:



When you charge the battery, do not smoke. Keep the battery away from any sparks. The fumes from the battery acid can cause an explosion.

## TO CHARGE THE "MAINTENANCE FREE" BATTERY

**NOTE:** Before you attach the battery cables, make sure the battery is fully charged. This will extend the life of the battery and provide the necessary power to start the engine.

4. Remove battery from lawn tractor (see **Battery Removal** paragraph in **Maintenance** section of this manual).
5. Remove the protective caps from the battery terminals.
6. Use a 12 volt battery charger to charge the battery. Charge at a rate of 6 amperes for one hour. If you do not have a battery charger, have an authorized service center charge the battery. Complete assembly section of this manual while waiting for battery to charge.
7. Reinstall battery (see **Battery Installation** paragraph in **Maintenance** section of this manual).

## STEERING WHEEL INSTALLATION (FIG. 2-ASSY)

1. Position front wheels straight forward.
2. Place spacer (if so equipped) on steering shaft.
3. Place steering shaft cover (if so equipped) over spacer.
4. Align cross holes in steering wheel and steering shaft. Make sure wheel single wheel spoke points down. **NOTE:** Use a small Phillips screwdriver with a 1/4 inch shaft to align holes.
5. Drive spring pin through holes with a hammer.

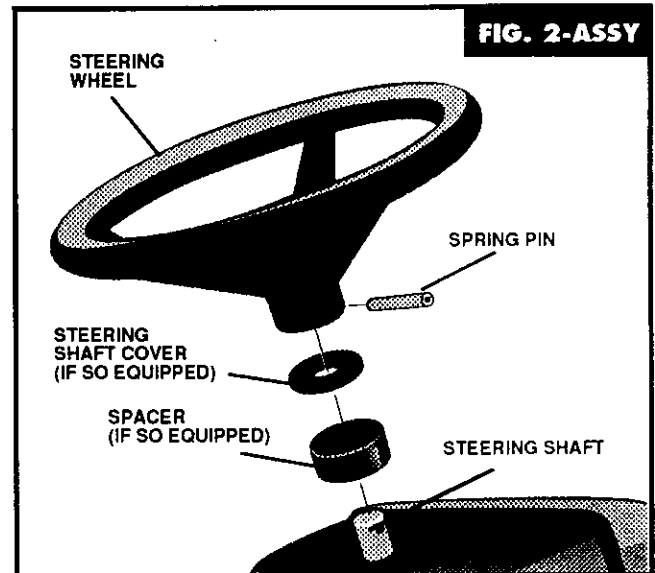

# ASSEMBLY

## TO ADJUST QUICK ADJUST SEAT (FIG. 3-ASSY)

If adjustment is needed:

1. Loosen T-knob located underneath seat (Do not remove).
2. Move seat forward or rearward to desired operator's position.
3. Tighten T-knob securely.

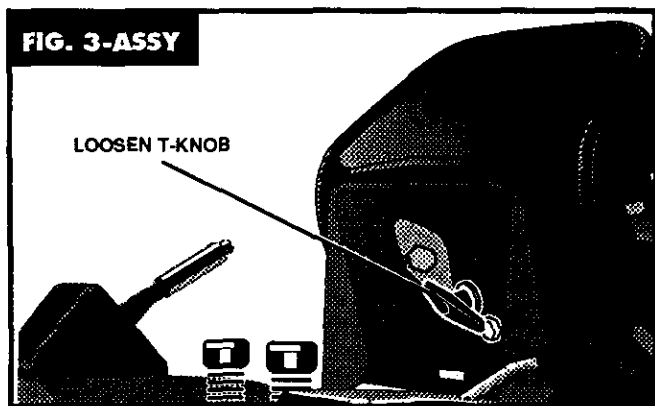

## TO SERVICE ENGINE (FIG. 4-ASSY)

1. Place tractor so engine is in a level position.
2. Raise hood to gain access to engine. **NOTE:** Raise and lower slowly to avoid personal injury or damage to tractor.
3. Remove oil fill cap/dipstick. Clean dipstick with a rag.
4. Check oil level. Use a funnel to add oil to the engine crankcase, if the oil level is below the full mark. See **Engine Operating and Maintenance** manual for proper procedure.
5. Reinstall oil fill cap/dipstick and tighten securely.
6. Check to make sure that spark plug wire(s) is attached to spark plug(s).
7. Fill gas tank with clean, fresh lead-free gasoline with a minimum rating of 77 octane. Low-lead or regular grade leaded gasolines are acceptable. Do not mix oil with gasoline. Be certain container is clean and free from rust or other foreign particles. Never use gasoline that may be stale from long periods of storage in the container.



Never fill the gas tank while the engine is running or is hot. Immediately wipe off any spilled gasoline before attempting to start engine.

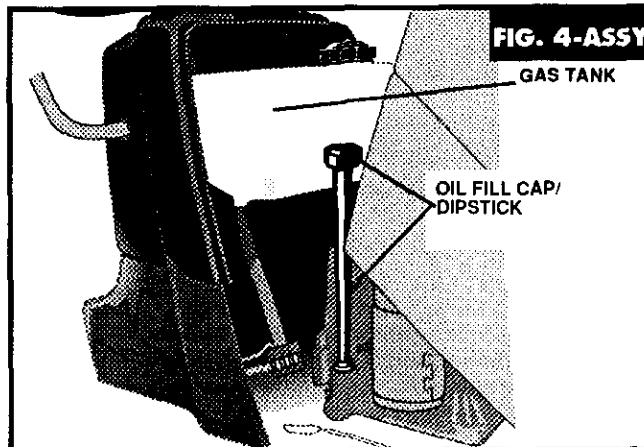

## TO SERVICE TRACTOR

1. Check tire pressure. Recommended operating tire pressure is 10 to 14 pounds per square inch. Check side wall of tires for manufacturer's maximum tire pressure. Do not exceed this pressure. Equal tire pressure should be maintained in all tires.
2. Check all nuts and bolts to be sure none are loose.
3. Return to the **To Activate Battery** paragraph in this section and complete the battery installation.

# OPERATION

The operation of this lawn tractor can result in objects being thrown into the eyes, which can result in severe eye damage. Always wear safety glasses or eye shields while operating a lawn tractor. We recommend standard safety glasses or a wide vision safety mask for over spectacles.

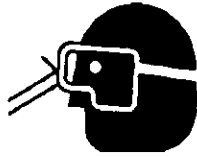

Get to know your lawn tractor and its controls. Be sure you (or any other operator) have read and understood the **Safety Pages** listed in the front of this manual.

Your new lawn tractor will give years of service if cared for properly. Never run into trees, curbs, etc. Service regularly and store in a dry area. Operate your lawn tractor at slow speeds until you become familiar with the machine. Avoid sharp turns at high speed and uphill or downhill turns. Operate tractor carefully. Be especially cautious on hills. When riding down inclines, keep shift control in low speed with brake-clutch pedal out. This allows the engine to control the speed. Use brake for fast stops on hills.

**KEEP MOWER CLEAN.** Grass clippings may pack under the mower deck due to the internal moisture content of the grass. This accumulation of cut grass should be removed after each mowing. Remove ignition key and scrape accumulation off with a putty knife or similar tool. Cleaning of the underside is easier if mower deck is removed. See **Mower Deck Removal** paragraph in **Maintenance** section of this manual. Remove dirt and debris from engine area with a brush or cloth.

## CONTROLS

**FIG. 1-OP** shows all operating controls. The controls and their functions are as follows:

 **Do Not operate this tractor without a chute deflector in place. A lawn tractor can be dangerous to operate if misused. On slopes, be very cautious and avoid sharp turns to prevent tipping or loss of control. NEVER carry passengers.**



**Battery Charge Indicator (if so equipped)**- Indicates whether battery is being recharged when engine is running. The battery charge indicator light is **GREEN**. When engine is running and light is lit this means the battery **IS** charging. If indicator is not on, have battery and/or engine charging system checked by an authorized service dealer.



**Oil Pressure Indicator (if so equipped)**- Indicates engine oil pressure. If it is lit, stop immediately and check the oil.



**All Systems Go Light** - If this indicator is lit, the engine will not start.

1. Your clutch-brake pedal may not be fully depressed.
2. The mower clutch lever may not be in the **DISENGAGE** position.

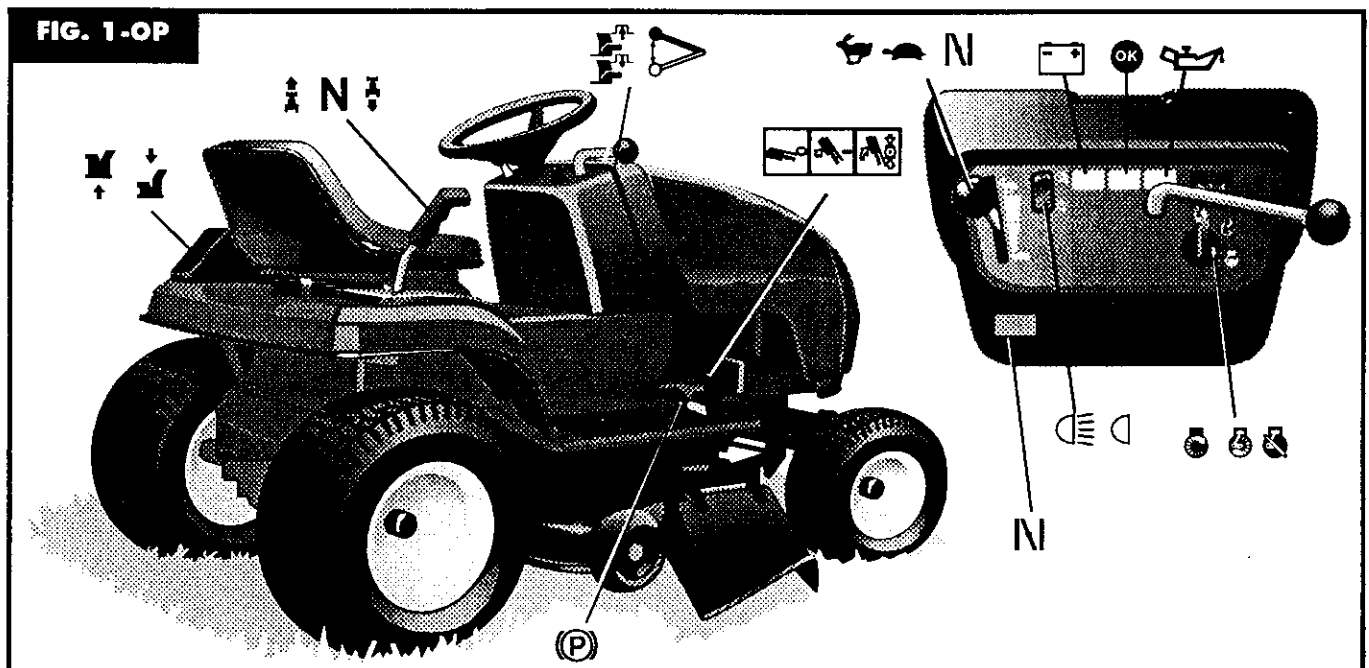

# OPERATION



**Throttle Control Lever** - Regulates engine and blade speed. Engine should always be run at fast speed for best grass cutting. **NOTE:** For models without a choke control button the choke is regulated with the throttle control lever.



**Ignition Switch** - Used to start and stop engine. Turn key all the way right to 3rd position to start engine. When key is released after starting engine it will return to 2nd position. To stop engine, turn key to 1st position. Remove key to lock ignition.



**Headlight Switch** - Turns headlights on and off. With engine running, push ON end of switch to turn headlights on. To turn headlights off push OFF end of switch.



**Hour Meter (if so equipped)** - Counts total number of hours lawn tractor has been operated. Use meter with **Maintenance Check List** to schedule maintenance for lawn tractor.



**Choke Control (if so equipped)** - Used to start cold engine.

**Ammeter (if so equipped)** - Indicates whether battery is being recharged when engine is running. If charge is not indicated while engine is running at full throttle, have engine charging system checked by an authorized engine service dealer.



**Transmission Control Lever** - Used to select ground speed ranges as well as direction of motion (forward-neutral-reverse). Forward speed ranges are labeled (1-2-3-4-5) or (1-2-3-4-5-6).

**No. 1 range** is slowest forward speed, used for traveling up or down steep hills or for snow removal.

**No. 2 range** is used for cutting tall or heavy grass.

**No. 3 range** is used for average mowing conditions.

**No. 4 range** is used for light mowing.

**No. 5 range** is used for very light mowing on smooth flat surfaces on a 6 speed. On a 5 speed it is used for transporting the unit.

**No. 6 range** should be used for transporting unit only.

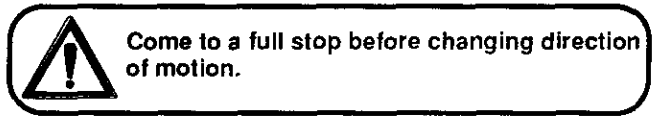

**Parking Brake Lever** - Used to lock brake-clutch pedal in brake position. **NOTE:** Check gear shift position and know operating intentions before releasing brake.

1. Depress brake-clutch pedal fully, engaging brake.
2. Push parking brake lever forward and engage notch in parking brake lever against main frame.
3. To release parking brake, apply pressure to pedal and spring will release parking brake lever.



**Brake-Clutch Pedal** - This is a dual purpose control. Press pedal halfway down to disengage clutch. It is used for changing speed range or direction of travel (forward or reverse). Release pedal to engage clutch. With pedal completely depressed, brake is applied.



**Mower Clutch Lever** - Used to engage or disengage the power to the mower deck blades. With mower clutch lever moved all the way to **DISENGAGE** (rearward) position, blades should stop in a safe period of time. Use **DISENGAGE** position when using a tractor for yard jobs such as pulling a roller, seeder, sweeper or other accessories.

1. Move lever slowly (**Never "snap" the lever**) toward front of lawn tractor to engage power to the blades. It is important to engage mower clutch lever while engine is running at full speed.
2. Move lever slowly toward rear of lawn tractor to disengage power to blades and to apply blade brakes.

**Mower clutch lever must always be in full DISENGAGE position to start engine. Never place lever in ENGAGE position until engine is warmed up and operator is on seat, ready to start mowing. Always return lever to DISENGAGE position before dismounting from tractor.**



**Blades will not stop immediately. Keep hands and feet from under the mower deck and away from the discharge chute.**



**Cutting Height Adjustment Lever** - Used to change height of cut. The bottom position of lever is the lowest cutting height and the top position is the highest cutting height. Other positions change height of cut approximately 1/2 inch each.

1. Grasp lever (**FIG.1-OP**) with left hand and pull upward to raise mower deck. You will hear a click sound as lever passes to next height position.
2. Grasp lever with left hand and pull upward slightly. Depress button on end of lever with thumb to release height adjustment lever latch and lower mower deck to desired height. Release latch button and allow lever to latch in place.

# OPERATION

## TO START ENGINE

Read **Operation** section in this manual and **Engine Operating** and **Maintenance** manual before trying to start engine.

**NOTE:** Be sure engine crankcase is filled to the full mark before starting engine. Never run engine unless crankcase is properly filled with oil and dipstick is tightened securely.

**IMPORTANT:** When starting engine, the brake-clutch pedal must be fully depressed and mower clutch lever must be in full **DISENGAGE** position to engage the lockout switches. The All Systems Go light (if so equipped) on dash will glow and engine will not crank unless these conditions are met.

Your lawn tractor is equipped with a seat switch. The engine will stop if operator is not firmly seated in operator's seat when mower clutch lever is engaged. Leaning forward or to one side on the seat may cause the engine to stop. To leave operator's seat, the brake-clutch pedal must be pushed all the way down and locked or engine will stop.

To start engine proceed as follows:

1. Check to make sure fuel tank contains clean, fresh gasoline, and engine crankcase is properly filled with oil.
2. Depress and hold brake-clutch pedal all the way down. Place shift lever in **NEUTRAL** position.
3. Place mower clutch lever in **DISENGAGE** position.
4. Place throttle control lever to **FAST** position.
5. A warm engine will require little or no choking. For cold starts place throttle control lever in choke position or pull choke control out. This will depend on the type choke your unit is equipped with.
6. Turn ignition key to **START** position. Release key when engine has started. **NOTE:** Continuous cranking of more than 15 seconds per minute can cause starter to overheat. Allow starter to cool two minutes after prolonged cranking of more than 15 seconds per minute.
7. After engine starts, move throttle control out of choke position to desired engine speed or gradually push choke control all the way in and move throttle control lever to desired engine speed. This will depend on the type choke your unit is equipped with.
8. To stop engine, turn ignition key to **OFF** position.

## IMPORTANT

Move throttle to slow before turning ignition off to reduce muffler "POP".

Failure to do so will result in engine and exhaust system damage.

If engine cranks but fails to start, proceed as follows:

1. Check to make sure fuel tank contains clean, fresh gasoline.
2. Check to make sure spark plug(s) is/are tightened securely into engine and spark plug wire(s) is/are attached to spark plug(s).
3. Carburetor adjustment may be necessary (see **Engine Operating and Maintenance** manual).

If engine does not crank, check the following:

1. Be sure brake-clutch pedal is fully depressed and mower clutch lever is in **DISENGAGE** position.
2. Be sure the battery has been serviced and charged.
3. Check fuse in red wire near back of ignition switch.



Never run engine indoors or in enclosed, poorly ventilated areas. Engine exhaust contains **CARBON MONOXIDE**, an **ODORLESS** and **DEADLY GAS**.

Keep hands, feet, hair and loose clothing away from any moving parts on engine or lawn tractor.

**WARNING-** Temperature of muffler and nearby areas may exceed 150° F. Avoid these areas.

## LAWN TRACTOR OPERATION

Take a comfortable riding position on seat of lawn tractor and start engine as outlined. After engine warm-up, move the transmission control lever to a slow speed position to get used to your lawn tractor. After you become familiar with the operation of your tractor, move the transmission control lever to a faster speed. With mower blades stopped, make your first run in a large, open, level area. Learn to start, stop, and change direction in this area. Once you learn to maneuver your lawn tractor, move throttle control to **FAST** position. **Slowly** move mower clutch lever to **ENGAGE** position and start mowing. To stop blades, move lever to **DISENGAGE** position. To stop engine, move throttle control to **SLOW** position, turn ignition key to **OFF** position. **CAUTION:** Disengage mower clutch lever, set parking brake, stop engine, lower mower deck and remove key before leaving operator's position. Always dismount from left side.

Your lawn tractor is equipped with a seat switch. The engine will stop if operator is not firmly seated in operator's seat when mower clutch lever is engaged. Leaning forward or to one side on the seat may cause the engine to stop. To leave operator's seat, the brake-clutch pedal must be pushed all the way down and locked or engine will stop.



## TO AVOID SERIOUS INJURY OR DEATH

Read Owner's/Operator's Manual(s).

Know location & function of all controls.

Keep guards, safety shields and switches in place and working.

Remove objects that could be thrown by blade(s).

Do not mow when children & others are around.

Never carry children or passengers.

Look down and behind before and while backing.

Do not mow where machine could tip or slip.

If machine stops going uphill, disengage blade(s) and back down slowly.

Remove key when leaving machine.

Avoid sudden turns.

Go up and down slopes, not across.



## MOWING HINTS

For best mowing results, engine should be run at fast throttle and ground speed controlled by shift control lever position. Forward speed of the lawn tractor must be controlled in accordance with the type and quantity of grass being mowed. The more grass that must be cut, the slower the speed forward should be. When cutting light grass, the forward speed can be increased. By observing the cutting action of your mower, you can determine how fast you can travel.

Your mower may tend to leave unmowed strips when long and tender grass is being mowed. Tender grass has a high internal moisture content and is easily depressed by the lawn tractor wheels, and may not always spring back in time to be cut. To overcome this condition, we advise mowing the lawn in a counterclockwise direction, overlapping previous cut, which allows the lifting action of the rotating blades to lift the grass into the cutting path.

The rear wheels are driven by a transaxle, similar to an automobile differential. This makes short turns possible and prevents marring of the lawn. It is possible to spin the drive wheels of the lawn tractor under adverse conditions. When one wheel slips, shift your weight over this wheel to obtain more pulling power. Your lawn tractor is very maneuverable and can be reversed to back out of dead ends. **CAUTION: Disengage mower blades before backing up. Carefully check area behind tractor for children or pets before backing up.**

## MULCHING MOWING TIPS

1. Blades must be sharp. A dull blade will rip or tear grass, creating an uneven appearing cut lawn.
2. Mow grass when it has grown 1/2-1 inch above the recommended height (consult your local nursery for advice on recommended height).
3. To achieve best mulching results, mow the lawn often enough to cut less than 1 inch.
4. Do not cut off more than 1/3 of the total height of the grass in one mowing. If the lawn is overgrown cut a little at a time and let grass recover before mowing again.
5. Avoid mowing wet grass. It will clog the mower deck and leave clumps of grass on the lawn. If this occurs even under normal conditions mow more frequently, at a slower speed, a narrower swath, or raise the cutting height.
6. Place engine throttle control in fast position when mowing.
7. Always clean under mower housing after each use.

## ALL-WHEEL STEERING FEATURE

Because both front and rear wheels turn, an all-wheel steering lawn tractor is very maneuverable. If the lawn tractor becomes wedged against a wall, fence or other obstruction, do the following:

1. Move transmission control lever to No. 1 position.
2. Turn steering wheel **slightly** away from obstruction. **NOTE:** If you turn sharply (7° or more), rear wheels will turn in opposite direction of front wheels (turning into obstruction you are trying to turn away from).
3. You can reverse tractor to back out of dead ends. **CAUTION: Before backing up, stop mower blades. Be sure tractor is completely stopped before shifting into reverse. Before backing up, carefully check the area behind the lawn tractor for children, pets, and other obstructions.**

# MAINTENANCE

The warranty on this lawn tractor does not cover items that have been subjected to operator abuse or negligence. To receive full value from the warranty, operator must maintain lawn tractor as instructed in this manual. The following Main-

tenance Check List is supplied to assist operator to properly maintain lawn tractor. This is a check list only. Adjustments referred to will be found in Adjustments section of this manual.

|   | BEFORE STORAGE | BEGINNING EACH SEASON | EVERY 100 HOURS | EVERY 50 HOURS   | EVERY 25 HOURS | MONTHLY | FREQUENTLY | AFTER FIRST 5 HOURS | BEFORE EACH USE  | MAINTENANCE CHECK LIST                        |  |  |  |  |  |  |  |  |  |  |
|---|----------------|-----------------------|-----------------|------------------|----------------|---------|------------|---------------------|------------------|---|--|--|--|--|--|--|--|--|--|--|
|   |                |                       |                 |                  |                |         |            |                     |                  | SERVICE RECORD                                |  |  |  |  |  |  |  |  |  |  |
|   |                |                       |                 |                  |                |         |            |                     |                  | FILL IN DATES AS YOU COMPLETE REGULAR SERVICE |  |  |  |  |  |  |  |  |  |  |
| Check Engine Oil Level                              | ●              | ●                     |                 |                  |                |         |            |                     |                  |   |  |  |  |  |  |  |  |  |  |  |
| Change Engine Oil                                   |                | ●                     |                 | ● <sub>1,2</sub> |                |         |            |                     | ●                |   |  |  |  |  |  |  |  |  |  |  |
| Change Oil Filter (if so equipped)                  |                |                       |                 |                  | ● <sub>2</sub> |         |            |                     | ● <sub>1,2</sub> |   |  |  |  |  |  |  |  |  |  |  |
| Clean Air Filter                                    |                |                       |                 |                  | ● <sub>2</sub> |         |            |                     | ●                |   |  |  |  |  |  |  |  |  |  |  |
| Change Spark Plug(s)                                |                |                       |                 |                  |                |         |            |                     | ●                |   |  |  |  |  |  |  |  |  |  |  |
| Replace Air Filter Paper Cartridge                  |                |                       |                 |                  |                |         |            |                     | ● <sub>1,2</sub> |   |  |  |  |  |  |  |  |  |  |  |
| Clean Air Screen                                    |                |                       |                 |                  | ● <sub>2</sub> |         |            |                     |                  |   |  |  |  |  |  |  |  |  |  |  |
| Inspect Muffler/Spark Arrestor                      |                |                       |                 |                  |                |         |            |                     | ●                |   |  |  |  |  |  |  |  |  |  |  |
| Replace Fuel Filter                                 |                |                       |                 |                  |                |         |            |                     |                  |   |  |  |  |  |  |  |  |  |  |  |
| Check Battery Fluid Level/Recharge (if so equipped) |                |                       |                 |                  |                | ●       |            |                     |                  |   |  |  |  |  |  |  |  |  |  |  |
| Clean Battery and Terminals                         |                |                       |                 |                  |                | ●       |            |                     |                  |   |  |  |  |  |  |  |  |  |  |  |
| Adjust Motion Drive Belt Tension                    |                |                       |                 |                  |                |         |            |                     | ●                |   |  |  |  |  |  |  |  |  |  |  |
| Check Brake Operation                               | ●              | ●                     |                 |                  |                |         |            |                     |                  |   |  |  |  |  |  |  |  |  |  |  |
| Check Transmission Cooling                          |                |                       |                 |                  |                | ●       |            |                     |                  |   |  |  |  |  |  |  |  |  |  |  |
| Check Tire Pressure (10-14 lbs)                     | ●              | ●                     |                 |                  |                |         |            |                     |                  |   |  |  |  |  |  |  |  |  |  |  |
| Adjust Mower Deck Belt                              |                |                       |                 |                  |                |         |            |                     | ●                |   |  |  |  |  |  |  |  |  |  |  |
| Sharpen or Replace Mower Blades                     |                |                       |                 |                  |                |         |            |                     | ● <sub>3</sub>   |   |  |  |  |  |  |  |  |  |  |  |
| Check for Loose Fasteners                           | ●              |                       |                 |                  |                |         |            |                     |                  |   |  |  |  |  |  |  |  |  |  |  |
| Clean Lawn Tractor                                  |                |                       | ●               |                  |                |         |            |                     |                  |   |  |  |  |  |  |  |  |  |  |  |
| See Lubrication Chart                               |                |                       |                 |                  |                |         |            |                     | ●                |   |  |  |  |  |  |  |  |  |  |  |

**NOTES:** 1. Change more often when operating under a heavy load or in **HIGH** temperatures. (90° and above)  
 2. Service more often when operating in dirty or dusty conditions. 3. Replace more often when mowing in sandy soil.



At no time during maintenance or adjustments can the lawn tractor be lifted more than 20 inches from level position without taking the following precautions:

1. Remove gasoline from tank and run engine until carburetor is dry.
2. Remove battery. (see BATTERY REMOVAL paragraph in MAINTENANCE section.)
3. Remove oil from crankcase.

## LUBRICATION

For lubrication frequency see Maintenance Check List. For lubrication points and type of lubricant see Lubrication Chart. The transmission has been lubricated for life.

## CLEANING LAWN TRACTOR

Grass clippings may pack under the mower deck due to the internal moisture content of the grass. This accumulation of cut grass should be removed after each mowing. Remove ignition key and scrape accumulation off with a putty knife or similar tool. Cleaning of the underside is easier if mower deck is removed. See paragraph **Mower Deck Removal**. Remove dirt and debris from engine area with a brush or cloth.

## ENGINE MAINTENANCE

See **Engine Operating and Maintenance** manual for maintenance instructions.

### MAINTAIN THE AIR FILTER

The air filter should be cleaned and/or replaced every 25 hours of operation under normal operating conditions; more often under dusty conditions. To clean the air filter see **Engine Operating and Maintenance** manual.

### SPARK PLUG MAINTENANCE

Spark plug should be checked periodically for excessive carbon and gap. The spark plug gap should be checked with a wire feeler gauge and set at .030 inch as shown in the **Engine Operating and Maintenance** manual.

### MAINTAIN THE OIL FILTER

The oil filter should be changed every 100 hours of operation under normal operating conditions, more often under severe conditions. See the **Engine Operating and Maintenance** manual for proper procedure.

### MAINTAIN THE FUEL FILTER

Check the in-line fuel filter at frequent intervals and replace before the screen becomes clogged with sediment. Make sure new filter is installed with the IN marking toward the tank and the OUT marking toward the engine. Check fuel system components frequently and replace any parts showing wear or cracks. See the **Engine Operating and Maintenance** manual for proper procedure.

## TO CHANGE CRANKCASE OIL (FIG. 1-MAINT)

Change crankcase oil after first 5 hours of operation and every 25 hours thereafter. See **Engine Operating and Maintenance** manual for proper procedure.

1. Place a flat bottom 2 quart container beneath oil drain valve.  
**NOTE:** The user has the option of connecting a vinyl hose (1/2" diameter) to port end of valve in order to drain used oil into container for disposal. Hose may be purchased at any local hardware store.

**NOTE:** It may be necessary to raise left side of lawn tractor (with blocks under left wheels) to get proper drainage.

2. Turn oil drain valve counterclockwise and pull to drain oil.  
**NOTE:** Oil fill cap/dipstick should be loosened to serve as an air vent.
3. To close oil drain valve push and turn clockwise. Remove oil fill cap/dipstick and refill crankcase as outlined in **Engine Operating and Maintenance** manual.
4. Reinstall oil fill cap/dipstick.

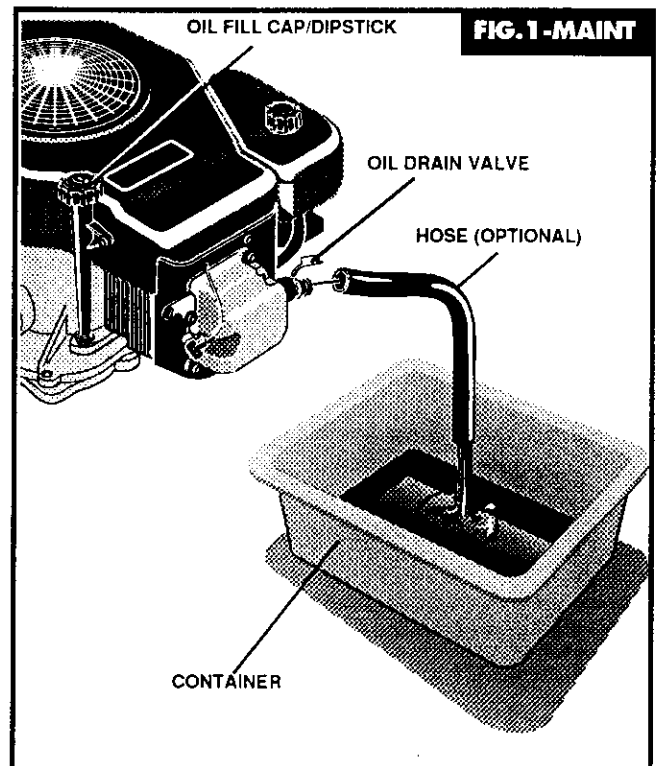

## LUBRICATION CHART

Orientation view only. Do Not stand on end.

GREASE WHEELS BEARINGS ON BOTH SIDES

GREASE ZERKS ON FRONT AXLE

OIL FRONT AXLES AND PIVOT POINTS ON BOTH SIDES

WIPE GREASE ON END OF DRAG LINK AND IN CAM SLOTS

OIL IDLER ARM SHOULDER BOLT

GREASE UNIVERSAL JOINTS ON BOTH SIDES

OIL STEERING PIVOT POINTS ON BOTH SIDES

GREASE ZERKS ON QUILL ASSEMBLIES

OIL MOWER DECK WHEELS ON BOTH SIDES

OIL MOWER DECK HITCH PIVOT POINTS

WIPE GREASE ON SECTOR GEAR AND STEERING GEAR

USE A GOOD GRADE OF CUP GREASE

USE SAME TYPE OIL USED IN CRANKCASE EVERY 25 HOURS OF OPERATION

## HEADLIGHT BULB REPLACEMENT (FIG. 2-MAINT)

**NOTE:** Do not remove the plastic headlamp lens when replacing the headlight bulbs.

1. Lift hood.
2. Turn the headlight harness (holding the bulb) 1/4 turn counterclockwise (to the left) and remove.
3. Pull the bulb out (do not unscrew). Push in new bulb.
4. Replace the headlight harness and turn a quarter turn clockwise to the right to lock in place.

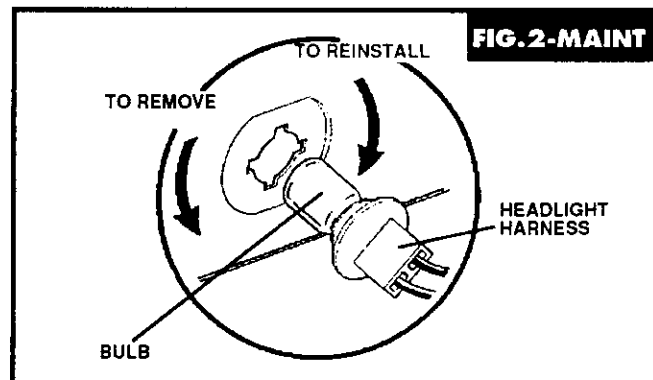

# MAINTENANCE



When you charge the battery, do not smoke. Keep the battery away from any sparks. The fumes from the battery acid can cause an explosion.



Always disconnect negative (black) cable first. Removing positive cable first can result in sparks if the wrench touches any metal surface. Be sure battery hold-down bracket does not touch battery terminals and cause a spark.

## BATTERY MAINTENANCE

When starter operates properly and battery connections are clean and tight but cranking difficulty is experienced, battery may not be charged. Battery should be taken to an authorized service station and tested.

If engine will not start right away under normal cranking speed, continued cranking will run down the battery and may cause damage to starter. Check ignition and fuel systems and correct any faults.

The battery should be kept clean. If the top has an accumulation of dirt or grease, remove the battery from vehicle for cleaning. The battery should be cleaned with a mild solution of baking soda and water. Brush this on, keeping vent plugs tightly in place to prevent any solution from entering the cells. Allow solution to work for a few minutes, then rinse with clean water and wipe battery dry. If battery terminals are corroded, clean with a wire brush and coat terminals with petroleum jelly. Be sure to reinstall battery in the same position and properly reconnect battery cables (red to positive, black to negative).

Proper care will lengthen battery life. When replacement becomes necessary, use battery of same size and type for continued trouble-free service (see **Repair Parts** section/manual).

## BATTERY REMOVAL (FIG.3-MAINT)

1. Raise seat and disconnect negative (black) battery cable and move away from terminal.
2. Pull away battery cable boot (if so equipped) from positive (+) battery terminal. Disconnect positive (red) battery cable from battery.
3. Remove plastic wing nut from battery hold-down rod.
4. Remove battery hold-down bracket and hold-down rod.
5. Lift battery out of tractor.
6. Reinstall battery (see **Battery Installation** paragraph).

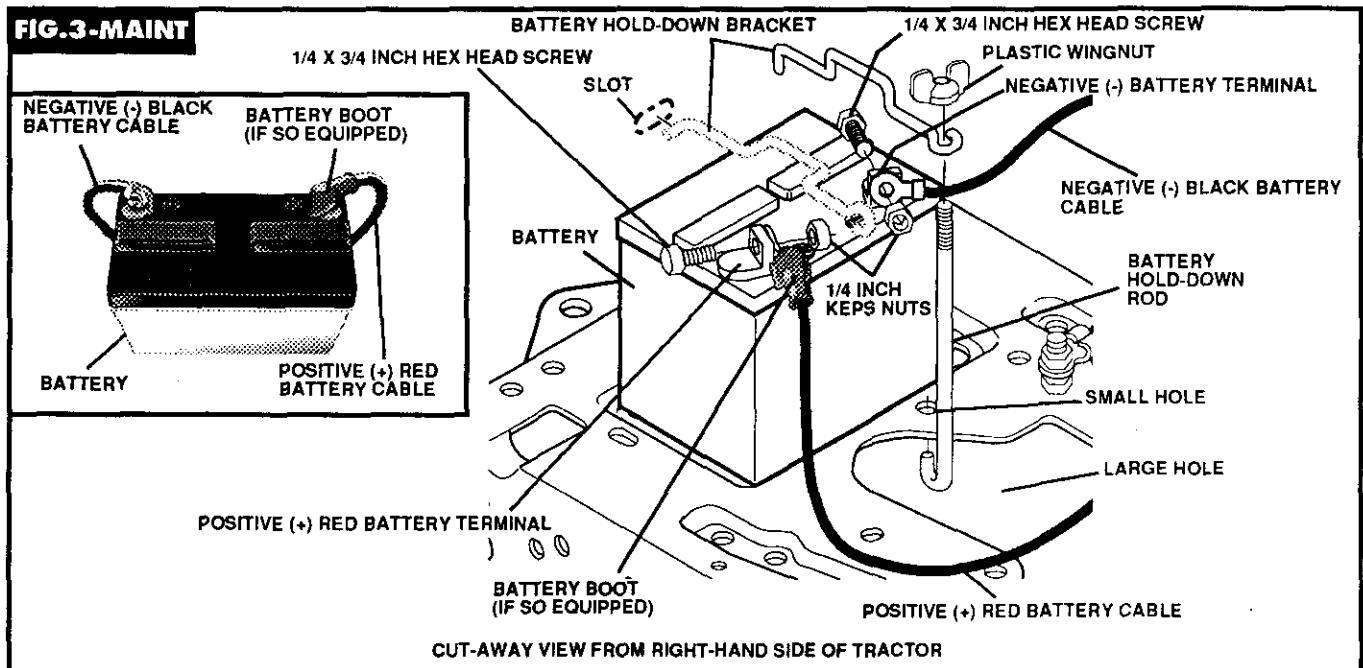

# MAINTENANCE



Always connect positive (red) cable first. Connecting negative cable first can result in sparks if the wrench touches any metal surface. Be sure battery hold-down bracket does not touch battery terminals and cause a spark

## BATTERY INSTALLATION (FIG.3-MAINT)

1. Raise seat plate and place battery back into tractor with positive (+) terminal toward right side of tractor.
2. Place battery hold-down bracket through slot in back of console. **NOTE:** Turn bracket to side, place through slot in console and rotate upright.
3. Place hook end of battery hold-down rod through shift lever hole in main frame and hook into small hole in front of battery.
4. Place threaded end of hold-down rod through loop in bracket and secure with plastic wingnut.
5. Attach positive (red) battery cable to positive (+) terminal on battery with a 1/4 X 3/4 inch hex head screw and a 1/4 inch keps nut.
6. Slide battery boot if so equipped up cable and over terminal.
7. Attach negative (black) battery cable to negative (-) terminal on battery with a 1/4 X 3/4 inch hex head screw and a 1/4 inch keps nut.

## BELT GUIDES

This unit is equipped with belt guides (FIG. 4-MAINT) located next to engine pulley. These belt guides are angle rods secured to main frame. The guides are moved (by loosening locknuts) before replacing belts. When repositioning (after new belt installation) allow 1/16 inch gap between guide and pulley.

## LAWN TRACTOR DRIVE BELT REPLACEMENT

Your lawn tractor uses v-belts made of special compounds. If any belt becomes worn or breaks, replace with **original equipment belt** (see **Repair Parts** section/manual). **NEVER USE A SUBSTITUTE.** To replace tractor drive belt proceed:

1. Remove mower deck. See **Mower Deck Removal** paragraph.
2. Depress brake clutch pedal and set parking brake.
3. Loosen clutch idler pulley mounting screw enough to allow belt to be removed between pulley and retainer (FIG.5-MAINT).
4. Remove belt from transaxle pulley (roll belt over top of pulley).
5. Replace belt with new original equipment belt in reverse order of removal. **NOTE:** Be sure drive belt is installed to inside of upper engine pulley belt guide (FIG. 4-MAINT).

6. Before clutch idler pulley and belt retainer are repositioned and tightened, make drive belt adjustment. See **Lawn Tractor Drive Belt Adjustment** paragraph in **Adjustments** section.
7. If blade drive belt needs replacement, do so before reinstalling mower deck assembly.
8. Reinstall mower deck in reverse order of removal.

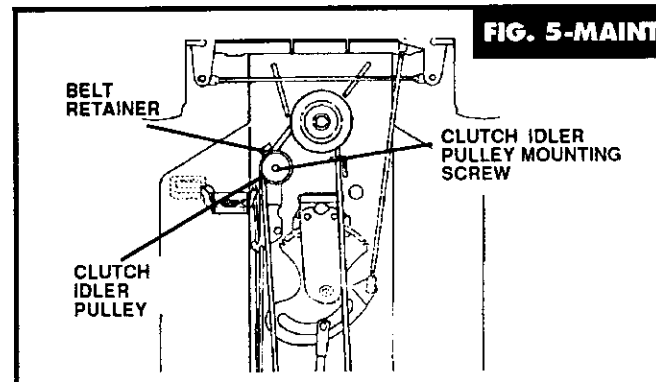
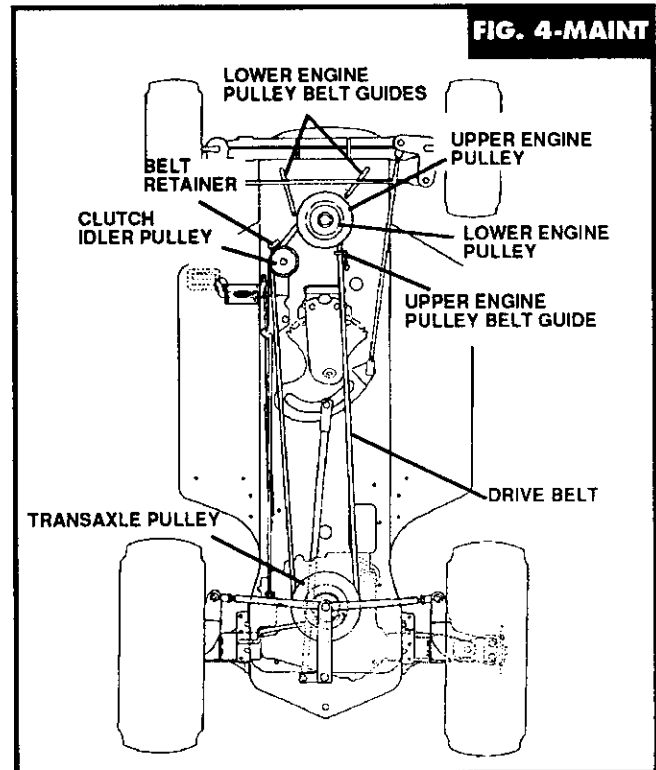

## MOWER DECK REMOVAL

1. Set parking brake.
2. Set mower clutch lever to the **DISENGAGE** position. Set cutting height adjustment lever to the lowest cut position.
3. Turn front wheels all the way to left to allow deck hitch to slide past right front wheel.
4. Remove hairpin cotter from mower deck hitch rod at front of deck (**FIG. 6-MAINT**). Remove hitch rod and lower deck hitch.
5. Remove hairpin cotter and flatwasher from right rear lift arm (**FIG. 6A-MAINT**). Slide right lift bracket off rear lift arm.
6. Remove hairpin cotter and flatwasher from left rear lift arm. Slide the left lift bracket off of the rear lift arm.
7. Slide deck toward front of tractor.
8. Flex lower pulley belt guides away from engine pulley and slip mower deck drive belt off lower engine pulley. Note original position of lower engine pulley belt guides (**FIG. 4-MAINT**). Correct distance between guide and pulley is 1/16". Loosen guides and swing away from pulley.
9. Move deck forward and remove the mower deck drive belt from the lower engine pulley.
10. Disconnect mower deck engagement cable (**FIG. 7-MAINT**) from mower deck clutch spring.
11. Place in high cut position, deck can now be pulled out from right side of unit.
12. Installation of deck is reverse of removal.

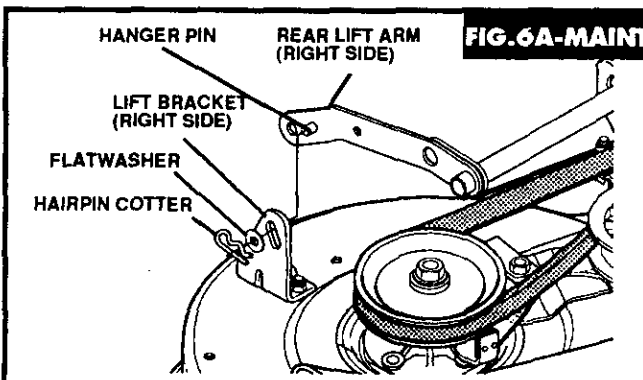
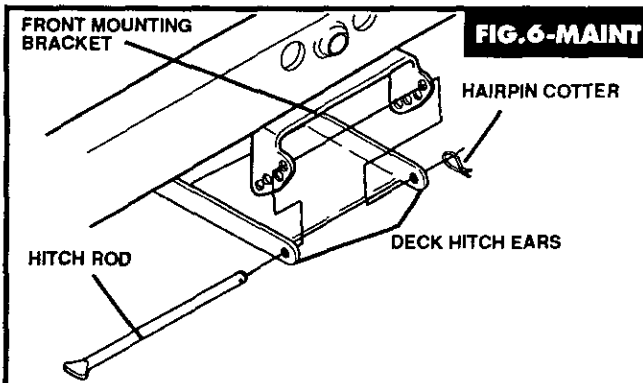

## BLADE DRIVE BELT REPLACEMENT (**FIG. 7-MAINT**)

1. Remove mower deck. See **Mower Deck Removal** paragraph.
2. Remove LH mower deck belt guard.
3. Note position of belt retainer on idler pulley so that retainer can be repositioned properly after belt installation. Loosen idler pulley.
4. Remove old belt and replace with a new original equipment belt.
5. Reinstall LH belt guard.
6. Reposition belt retainer and retighten idler pulley.
7. Reinstall mower deck assembly.
8. Adjust belt as described in paragraph **Blade Drive Belt Adjustment** in **Adjustments** section. Adjustment in **Adjustments** section.

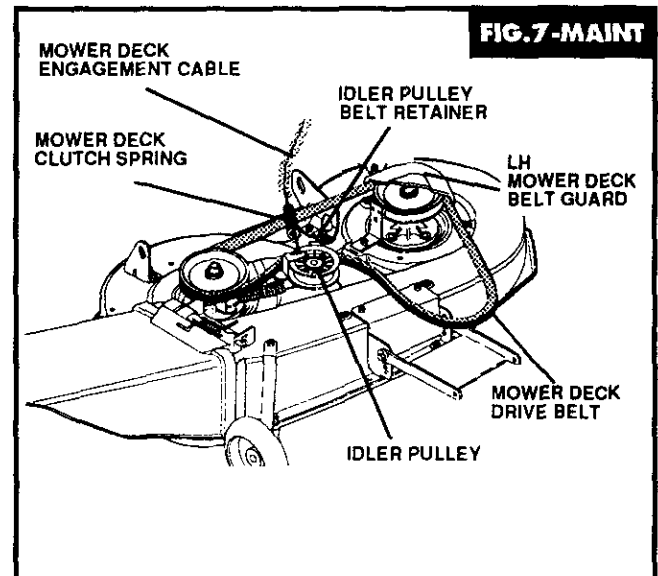

# MAINTENANCE

## BLADE REPLACEMENT (FIG. 8-MAINT)

The cutting blades should be sharp and well-balanced to run smoothly. Blades should have correct amount of "lift" for proper cutting and discharge of clippings. Lift is created by up-turned bent tip edges of blade ends. As cutting edges of blades wear, the bent tip edges also wear, decreasing blade lift, resulting in decreased cutting ability. It is recommended blades be replaced when upturned ends show signs of wear.

**IMPORTANT:** Stop engine and inspect blades at once if you strike any solid unyielding object. Check to make sure blade mounting screws are tight. To remove blades:

1. Remove mower deck. See **Mower Deck Removal** paragraph.



**DO NOT** handle blades with bare hands. Wear gloves or wrap blade with newspaper or other material while removing or installing blade.

2. With a 9/16 inch wrench, remove blade mounting screws by turning screws counterclockwise.

When replacing blades, be sure all parts are reassembled in proper order (see **Repair Parts** section/manual) or severe vibration will occur. Bent tip edges of blades must be up toward top of mower deck or blades will not cut. **NOTE:** Make sure blade mounting screws are tightened securely. We recommend using a 10 inch wrench or a torque wrench. If a torque wrench is used, torque blade mounting screws to between 30 and 35 foot pounds.

3. Reinstall mower deck.

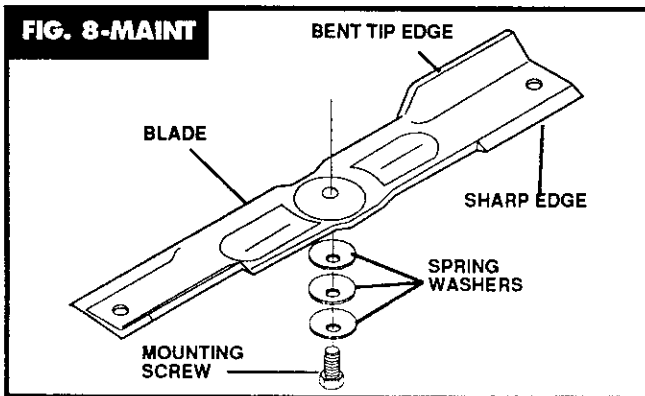

## TO SHARPEN BLADE (FIG. 9-MAINT)

Care should be taken to keep blades balanced. An unbalanced blade will cause excessive vibration and eventual damage to mower and engine.

1. Blade can be sharpened with a file or on a grinding wheel. Do not attempt to sharpen while on mower.
2. Place center hole of blade over head of the nail or end of a screwdriver clamped horizontally in a vice. If blade is balanced, it should remain in a horizontal position. If either end of the blade moves downward, sharpen heavy end until the blade is balanced.

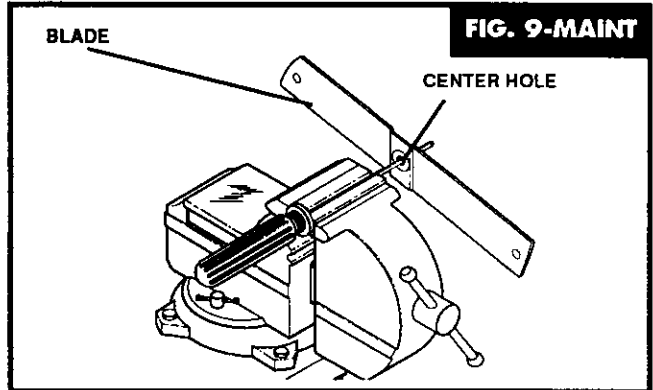

## MULCHING PLUG INSTRUCTIONS (FIG. 9A-MAINT)

If your tractor has a mulching kit installed on the mower deck and you want to convert from mulching to regular lawnmowing, the mulching plug may be removed as follows:

**NOTE:** If mulching plug is supplied in a kit installation is reverse of removal.

**NOTE:** If mulching blades are not installed see **Blade Replacement** paragraph in this section.

1. Remove the two 5/16-18 wing nuts and 5/16 lock washers from atop of mulching plug installed inside mower deck chute.
2. The two 5/16-18 x .75 inch carriage bolts will drop and can be easily removed from underneath the mulching plug and toe guard.
3. Remove mulching plug from mower chute. **DO NOT** remove toe guard. Your tractor is now ready to be used as a conventional mower.
4. Store mulching plug and hardware in a safe place for future use.
5. To reinstall plug reverse the above steps.

**IMPORTANT:** On installation head of carriage bolt must be to underneath side of skid bar.

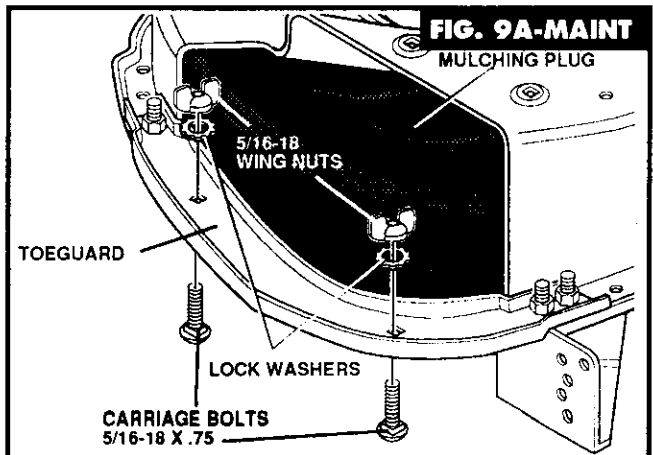

**CAUTION:** DO NOT OPERATE THE MOWER WITHOUT DISCHARGE CHUTE DEFLECTOR IN PLACE.



# ADJUSTMENTS



Keep hands, feet, hair, and loose clothing away from any moving parts on engine or lawn tractor when making any adjustments that require engine to be running. **DO NOT** carry passengers.

Located beneath the main frame are two v-belts. One v-belt (lawn tractor drive belt) transmits power to the transaxle, which in turn transmits power to the rear wheels. The other v-belt transmits power to the mower blades.

Located on the mower deck is a clutch that disengages power to the blades and a deck leveling adjustment.

Before any adjustments are made, it is necessary that you understand the function of the brake, clutch, and the brake-clutch pedal. The pedal disengages the clutch when partially depressed and applies the brake when fully depressed. Adjustment of the lawn tractor drive belt and brake must be synchronized so brake does not grab before clutch disengages. An incorrect adjustment causes brakes to grab or hold while power is being transmitted to the rear wheels. Lawn tractor will try to move with brake applied; this will cause difficulty when shifting from one speed range or direction to another.

To replace drive belt, you must remove mower deck. Removal of deck isn't necessary for other adjustments, but if several adjustments are needed, it will be more convenient if deck is removed.



At no time during the adjustment or repairs can the lawn tractor be lifted more than 20 inches from level position without taking the following precautions:

1. Remove gasoline from tank and run engine until carburetor is dry.
2. Remove battery. (see **BATTERY REMOVAL** paragraph in **MAINTENANCE** section of this manual.)
3. Remove oil from crankcase.

## LAWN TRACTOR DRIVE BELT ADJUSTMENT

The drive belt is kept tight by a spring attached to the brake-clutch pedal assembly. The Brake-clutch pedal in fully released position should appear as shown in **FIG. 1-ADJ** when drive belt is properly adjusted.

**FIG. 1-ADJ**

BRAKE-CLUTCH PEDAL

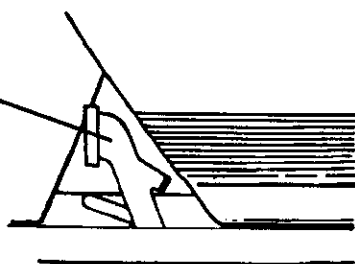

If drive belt requires adjustment, adjust as follows:

1. Depress brake-clutch pedal far enough to latch parking brake lever in third notch (**FIG. 2-ADJ** inset).
2. Loosen clutching idler pulley (**FIG. 2-ADJ**) mounting screw.
3. If brake-clutch pedal was too far forward, slide idler pulley in toward engine pulley. If pedal was too far rearward, slide idler pulley out away from engine pulley.
4. Retighten idler pulley mounting screw. **NOTE:** Belt retainer should point toward position where running board meets main frame (**FIG. 2-ADJ**).
5. Release brake-clutch pedal and recheck pedal for proper position. Readjust if necessary.
6. Check lawn tractor brake adjustment as outlined in paragraph **Lawn Tractor Brake Adjustment**.

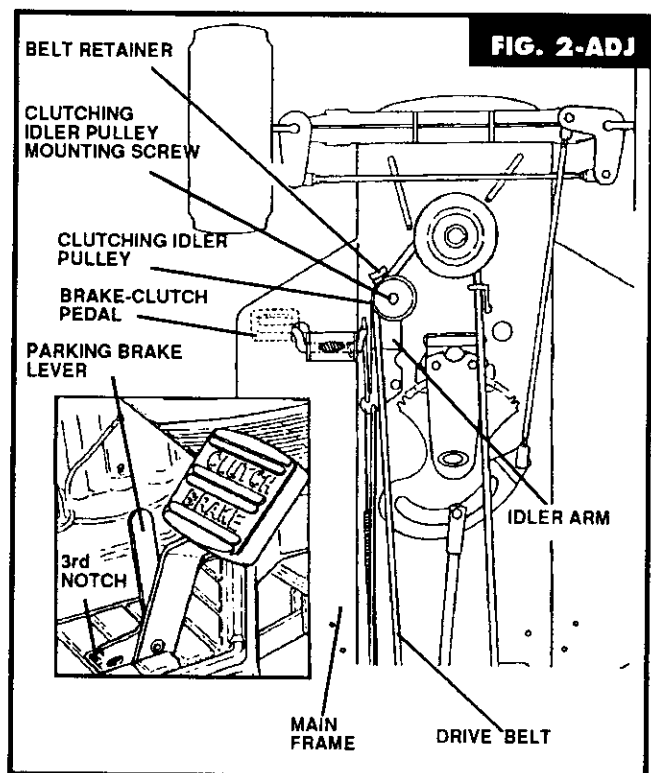

**FIG. 2-ADJ**

## LAWN TRACTOR BRAKE ADJUSTMENT

Your tractor is equipped with an adjustable disc brake mounted on the transaxle.

**To check brake operation:**

1. Stop tractor on a hard flat surface and turn off engine.
2. Place shift control lever in **NEUTRAL** position.
3. Depress brake-clutch pedal enough to latch parking brake in 2nd notch (**FIG. 2-ADJ**).
4. Try to push tractor. If you are unable to push tractor, brake is too tight and should be loosened (see **To adjust tight brake**).
5. Depress brake-clutch pedal enough to latch parking brake in 4th notch (**FIG. 2-ADJ**).
6. Try to push tractor. If you are able to push tractor, brake is too loose and should be tightened (see **To adjust loose brake**).

# ADJUSTMENTS

## LAWN TRACTOR BRAKE ADJUSTMENT (CONT.)

### To adjust loose brake:

1. Place shift control lever in **NEUTRAL** position and depress brake-clutch pedal enough to latch parking brake in 4th notch.
2. Turn brake adjusting nut clockwise until you cannot push tractor.
3. Recheck tractor brake adjustment as outlined in **To check brake operation**.

### To adjust tight brake:

1. Place shift control lever in **NEUTRAL** position and depress brake-clutch pedal enough to latch parking brake in 2nd notch.
2. Turn brake adjusting nut counter-clockwise until you can push tractor.
3. Recheck tractor brake adjustment as outlined in **To check brake operation**.

During tractor operation, check for stopping distance. If tractor requires more than six (6) feet for stopping distance at high speed in highest gear, the brake must be adjusted (see **Lawn Tractor Brake Adjustment** above)

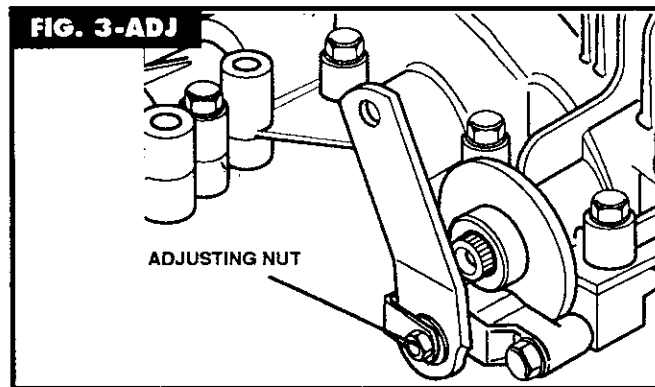

## MOWER DECK HEIGHT ADJUSTMENT

Before making any mower deck height adjustments, check air pressure in all four tires. All tires must be properly inflated. Recommended air pressure is 10 to 14 pounds per square inch. Check side wall of tire for manufacturer's maximum tire pressure. Do not exceed this pressure. Equal tire pressure should be maintained in all tires.

Main frame on lawn tractor should be level across the front from left side to right side. If main frame will not sit level, the two outside axle mounting screws may be too tight. The two outside mounting screws must be loose enough to allow front axle to pivot. **NOTE: DO NOT loosen center mounting screw.**

1. Park lawn tractor on firm level surface, such as a driveway or garage floor.
2. Place mower deck height adjustment lever in high cut position.

3. Measure height from the bottom of the left hand blade mounting screw to ground. Height should be 3-1/2 inches with mower deck set in high cut.
4. If adjustment is necessary, block up mower deck with a 2 x 4 and set height adjustment lever to low cut position.
5. Remove hair pin cotter (**FIG. 4-ADJ**) from clevis pin. Remove clevis pin.
6. Loosen hex jam nut on cable above clevis. Turn clevis clockwise to raise mower deck. Turn counterclockwise to lower deck. Each 1-1/2 complete turn of clevis represents approximately 1/8 inch change in the height of mower deck.
7. Reinstall clevis and clevis pin. Return height adjustment lever to high cut position and remove wood block from under deck.
8. Check mower deck height measurement. If measurement is correct reinstall hairpin cotter and tighten jam nut. If more adjustment is necessary repeat preceding instructions.
9. Check and adjust level of mower deck as outlined in paragraph **Mower Deck Leveling Adjustment**.

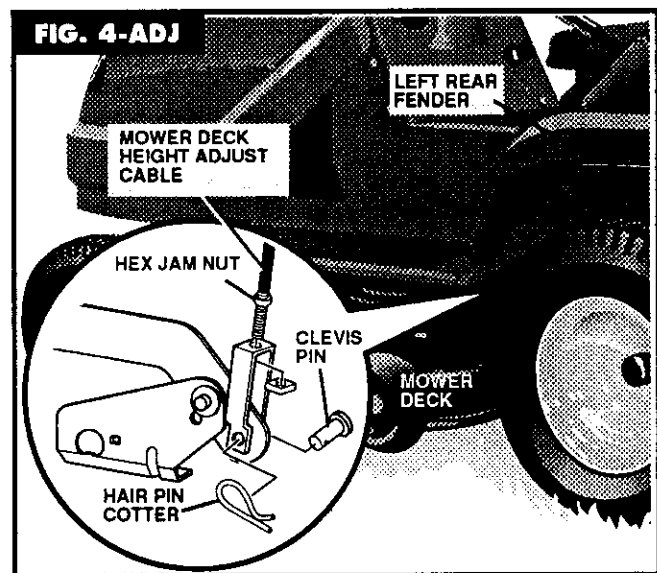

## MOWER DECK WHEEL ADJUSTMENT

Mower deck wheels may be adjusted to four positions. Both wheels must be adjusted to the same position. **NOTE: Do Not** adjust wheels to support mower deck while mowing or uneven cutting will result.

### To adjust mower deck wheels proceed:

1. Park lawn tractor on firm level surface, such as a driveway or garage floor.
2. Set cutting height adjustment lever to lowest anticipated cutting height.
3. Adjust wheels to a position 1/8 inch to 1/4 inch above the ground. Change wheel height adjustment by relocating shoulder bolt in one of four positions in wheel mounting bracket.

# ADJUSTMENTS

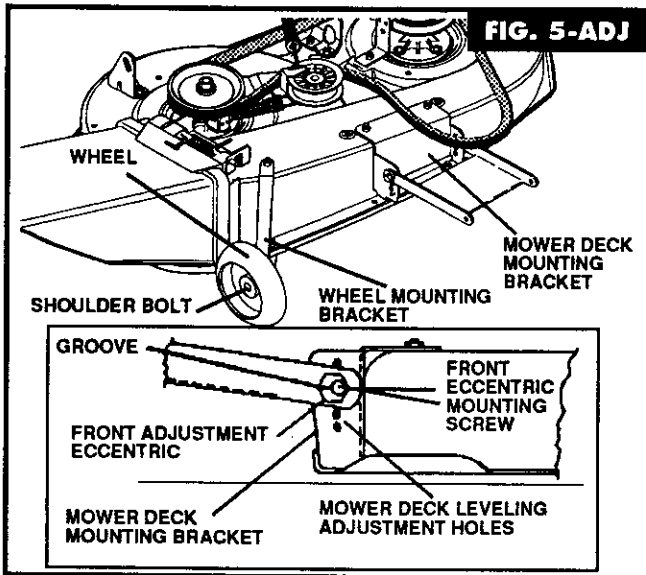

## MOWER DECK LEVELING ADJUSTMENT

Before making any mower deck leveling adjustments, check air pressure in all four tires. Recommended air pressure is 10 to 14 pounds per square inch. Check sidewall of tires for manufacturer's maximum tire pressure. Do not exceed this pressure. Equal tire pressure should be maintained in all tires.

Tractor main frame should be level across the front from left side to right side. If main frame will not sit level, the two outside axle mounting screws may be too tight. The two outside mounting screws must be loose enough to allow front axle to pivot. **NOTE: DO NOT loosen center mounting screw.**

The mower deck level can be adjusted from front to back and from side to side. Always adjust front to back level first.

1. Park tractor on firm level surface, such as a driveway or garage floor.
2. Check and adjust height of mower deck as outlined in **Mower Deck Height Adjustment** paragraph.
3. Place mower deck cutting height adjustment lever/pedal in mid cut position. **NOTE:** All adjustments will be made from mid cut position.

### To adjust front to back level.

4. Measure height, from level surface, of right side blade tips at front and rear of mower deck (be sure all tires are properly inflated). If distances are equal or not more than 1/8 inch lower in front, no front to back adjustment is necessary.
5. If adjustment is necessary, loosen front eccentric mounting screws (FIG. 5-ADJ) and turn front adjustment eccentric clockwise or counterclockwise as required. **NOTE:** When groove on eccentric is pointed straight forward (FIG. 5-ADJ inset) front of deck is at the lowest point. Turn both eccentrics so grooves are pointing same direction (upward or downward). Always keep grooves toward front of lawn tractor.

If more adjustment is necessary, front of mower deck may be raised or lowered by relocating eccentric mounting screws in higher or lower hole position on mower deck mounting bracket.

6. Hold eccentric with a wrench while tightening eccentric mounting screws securely.

### To adjust side to side level.

7. Measure height, from level surface, of left and right blade tips at outside edge of deck. If blades are equal or not more than 1/8 inch different, no side to side adjustment is necessary.
8. If adjustment is necessary, loosen right side eccentric mounting screw (FIG. 6-ADJ) and turn eccentric clockwise or counterclockwise as required to level mower deck. **NOTE:** When groove in eccentric is pointing downward, right side of deck is in lowest position. When groove is pointing upward, right side of deck is in highest position.
9. Hold eccentric with a wrench while tightening right side eccentric mounting screw securely.

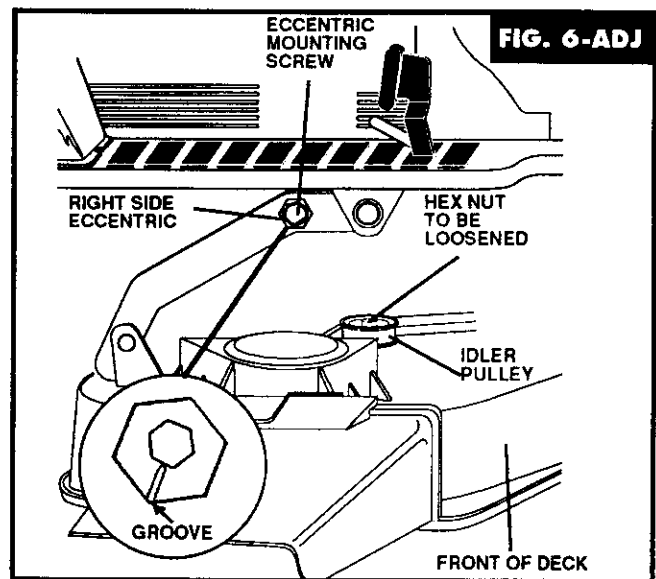

## BLADE DRIVE BELT ADJUSTMENT

When mower blade drive belt slips and blades will not rev to full speed while mowing, the blade drive belt should be tightened.

### To adjust:

1. Place mower clutch lever in **DISENGAGE** position.
2. Loosen idler pulley hex nut (FIG. 6-ADJ). Note position of belt retainer location and replace in same location after making adjustment.
3. Slide idler pulley toward center of deck to tighten belt. **NOTE:** Only a small amount of movement should be required.
4. Re-tighten hex nut on idler pulley.
5. To check adjustment start engine and run engine at **FAST** throttle setting. Engage mower clutch lever and allow sufficient time for blades to run to full speed, then disengage mower clutch lever. Blades should stop within a few seconds and remain stopped. If blades do not stop or tend to creep, adjustment is too tight.
6. To loosen blade drive belt, reverse step 3 above.

# ADJUSTMENTS

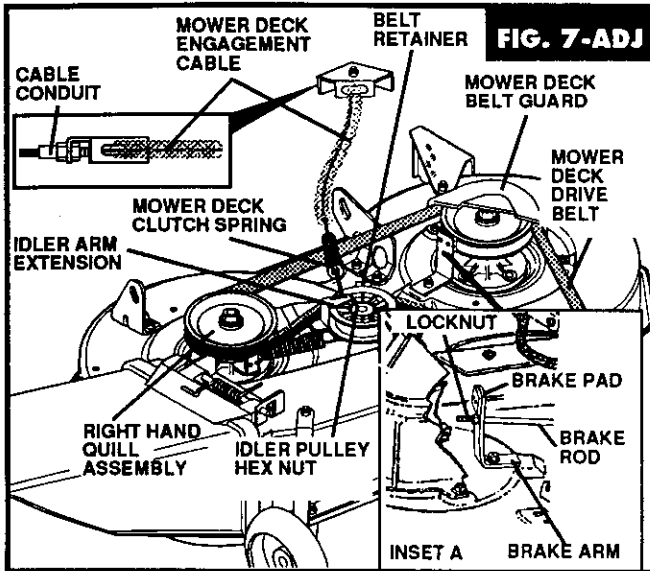

## BLADE BRAKE ADJUSTMENT

Brake pad should completely clear quill assembly when mower clutch lever is in **ENGAGE** position.

1. Place height adjustment lever/pedal in lowest cut position.
2. Move mower clutch lever back to disengaged position.
3. In the disengaged position there should be no tension on the mower deck clutch spring. There should be only enough slack as to allow approximately 1 inch total sideways movement on the cable/spring junction. This ensures that the brake engagement spring is exerting proper pressure to stop the right side blade effectively. Make adjustment if necessary for the proper disengaged position requirements.
4. If adjustment is necessary, proceed as follows:
  - a. Move Spring hook to another hole on idler arm extension.
  - b. Adjust cable conduit end. To increase or decrease cable slack.
5. Check adjustment on left hand brake pad. Locknut on end of brake rod should be approximately 1/8 inch from brake pad mounting bracket with mower clutch lever disengaged and left hand brake pad against quill pulley. Adjust locknut if necessary.

## STEERING GEAR ADJUSTMENT (FIG. 8-ADJ)

If excessive play develops in steering, adjust pinion and sector gears as follows:

1. Position front wheels straight forward.
2. Arrows should align in pinion and sector gear.
3. Slightly loosen mounting screws in lower steering shaft bearing.
4. Move lower steering bearing toward back of tractor, as needed.
5. Hold bearing in place, tighten mounting screws securely. Use a 10-inch wrench or a torque wrench. If torque wrench is used, torque mounting screws to between 30 and 35 foot pounds.

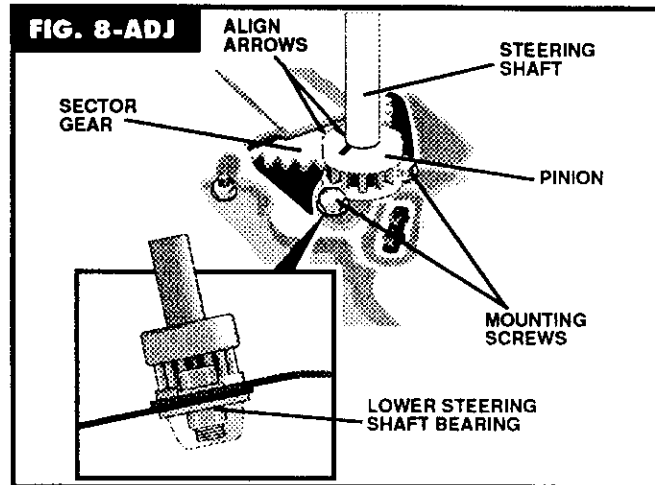

## TRANSMISSION CONTROL LEVER ADJUSTMENT (FIG. 9-ADJ)

Should the lawn tractor fail to shift correctly when you shift into a forward, neutral or reverse position, the transmission control lever may need adjusting.

**To adjust transmission lever:**

1. Locate true neutral by choosing a transmission control lever position and attempting to push the tractor. You should be able to push the lawn tractor when the transmission control lever is in the true neutral position.
2. Loosen the screw on the shift bracket on top of the transaxle. (See 'A' in FIG. 9-ADJ).
3. Place the transmission control lever into the center of the neutral slot.
4. Tighten screw 'A'.
5. Check the transmission control lever adjustment by pushing the lawn tractor. Put the transmission control lever in neutral slot. You should be able to push the lawn tractor. You should not be able to push the lawn tractor when you shift to forward or reverse.

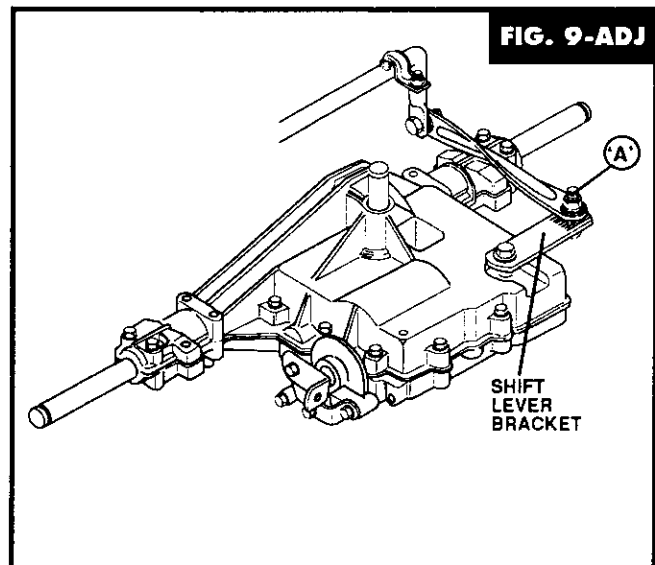

## ENGINE ADJUSTMENTS

See **Engine Operating and Maintenance** manual for engine adjustment instructions.

# TROUBLESHOOTING GUIDE

| PROBLEM                                   | CORRECTION   |
|---|--|
| Mower Cuts Ragged or Uneven               | <ol style="list-style-type: none"> <li>1. Remove any accumulation of grass clippings from underside of mower deck housing.</li> <li>2. Make certain blades are sharp and in good condition (not bent or incorrectly mounted).</li> <li>3. Check blade mounting screw(s). Blade screw(s) must be tight.</li> <li>4. Check mower deck leveling adjustment per manual. Adjust if necessary.</li> <li>5. Check blade belt tension per manual. Adjust if necessary.</li> <li>6. Check quill assembly(s) for damage or wear. Replace if necessary.</li> <li>7. Check for possible damage to mower deck housing. Repair or replace if necessary.</li> <li>8. Check pivot tube (if so equipped) assembly for damage. If bent or damaged, repair or replace.</li> <li>9. Check deck wheels being run on ground.</li> </ol>  |
| Mower Leaves Unmowed Strip Between Blades | <ol style="list-style-type: none"> <li>1. Mowing a heavy stand of grass or grass with excessive surface moisture could allow mower to leave an unmowed strip.</li> <li>2. Forward speed should be adjusted to mowing conditions by transmission lever position. Engine should be run at full throttle.</li> <li>3. Make certain blades are sharp and in good condition. Replace if necessary.</li> <li>4. Check blade belt tension. Adjust if necessary.</li> <li>5. Check quill assembly(s) for damage or wear. Replace if necessary.</li> <li>6. Check for damage to mower deck housing. Repair or replace if necessary.</li> </ol>  |
| Mower Scalps Lawn                         | <ol style="list-style-type: none"> <li>1. Check mower height adjustment setting and readjust if needed. Scalping is more likely on rough or uneven lawns.</li> <li>2. Check for damage to mower deck housing. Repair or replace if necessary.</li> <li>3. Check for bent blade(s) or quill assembly(s). Replace if necessary.</li> <li>4. Check mower deck leveling adjustment and adjust if necessary.</li> <li>5. Check for damaged deck wheels.</li> </ol>  |
| Mower Will Not Discharge Clippings        | <ol style="list-style-type: none"> <li>1. Remove any accumulation of grass clippings from underside of mower deck housing.</li> <li>2. Wet conditions can cause the discharge chute and underside of mower deck to become plugged with clippings. <b>Do not mow wet grass.</b></li> <li>3. Forward speed should be adjusted to mowing conditions by transmission lever position. Engine should be run at full throttle.</li> <li>4. When mowing long grass make first cutting in high position, then re-cut at normal cutting height.</li> <li>5. Check blade belt tension per manual. Adjust if necessary.</li> <li>6. If blade(s) have been replaced, make sure they have been correctly mounted.</li> <li>7. When mulching plug is installed clippings will not discharge.</li> </ol>   |
| Blade Drive Belt Comes Off During Use     | <ol style="list-style-type: none"> <li>1. Blade drive belt may suffer internal damage to cords when it comes off during use. If belt still comes off after checking all steps below, replace with a new original equipment belt.</li> <li>2. Check belt tension per manual. Adjust if necessary.</li> <li>3. Check belt guide. Correct clearance is 1/16 inch from belt when blade engage lever is engaged.</li> <li>4. Check mower deck leveling adjustment per manual. Adjust if necessary.</li> <li>5. Check for and remove any foreign objects interfering with belt travel.</li> <li>6. Check all pulleys on mower deck. A bent or split pulley could cause problems. Replace if necessary.</li> <li>7. Check engine drive pulley inner surface. If inner surface is rough or split, pulley should be replaced.</li> <li>8. Check blade engagement idler assembly for wear. Replace necessary parts.</li> </ol> |
| Blade Drive Belt Slips                    | <ol style="list-style-type: none"> <li>1. If grass is too high or wet, belt slippage may occur.</li> <li>2. Check belt for wear or damage. Replace if necessary.</li> <li>3. Check blade belt tension per manual. Adjust if necessary.</li> <li>4. Check blade drive belt tension spring. If spring is stretched or damaged, replace spring.</li> </ol>  |
| Blade Drive Belt Wears Excessively        | <ol style="list-style-type: none"> <li>1. Check all belt guides. Correct clearance is 1/16 inch from belt when blade engage lever is engaged.</li> <li>2. Check for and remove any foreign objects interfering with belt travel.</li> <li>3. Check pulleys for damage. Replace if necessary.</li> <li>4. Make certain blade brake is clearing belt when mower clutch lever is engaged. Adjust or replace if necessary.</li> <li>5. Make certain mower deck leveling adjustment is correct. Adjust if necessary.</li> <li>6. Check blade belt tension per manual. Adjust if necessary.</li> </ol>   |
| Blade(s) Will Not Engage                  | <ol style="list-style-type: none"> <li>1. Check belt. If worn or broken, replace. If belt is too loose, make belt adjustment.</li> <li>2. Check engagement spring on deck engagement idler. If broken or damaged, replace.</li> <li>3. Check for and remove any foreign objects interfering with engagement idler travel.</li> </ol>   |
| Blade(s) Will Not Disengage               | <ol style="list-style-type: none"> <li>1. Check blade belt tension per manual. Adjust if necessary.</li> <li>2. If blade belt adjustment will not provide enough slack in drive belt, replace with correct <b>Original Equipment Belt</b>.</li> <li>3. Check for and remove any foreign objects interfering with engagement idler travel.</li> </ol>   |

# TROUBLESHOOTING GUIDE

| PROBLEM   | CORRECTION  |
|---|---|
| Extreme Vibration Occurs When Blade Is Engaged            | <ol style="list-style-type: none"> <li>1. Check blade(s) and make certain they are not bent, out of balance or loose. Replace if necessary.</li> <li>2. Check belt for burn spots or irregularities that might cause vibration. Replace if necessary.</li> <li>3. Check quill assembly(s) for damage or wear. Replace if necessary.</li> <li>4. Check for worn or damaged blade engagement parts. Repair or replace if necessary.</li> <li>5. Check engine drive pulley inner surface. If inner surface is rough or split, pulley should be replaced.</li> <li>6. Check under side of mower deck housing for accumulation of clippings. Remove accumulated clippings.</li> <li>7. Check for loose or damaged engine mounts. Tighten or replace as necessary.</li> <li>8. Check blade belt tension per manual. Adjust if necessary.</li> </ol>   |
| Unit Drive Belt Slips                                     | <ol style="list-style-type: none"> <li>1. Check unit drive belt adjustment(s). Adjust if necessary.</li> <li>2. Check for damaged or broken clutching idler spring. Replace if necessary.</li> <li>3. Check belt(s) for wear or damage. Replace if necessary.</li> <li>4. Check for and remove any foreign objects obstructing clutching idler mechanism.</li> <li>5. Check for split engine or transmission pulley. Replace if necessary.</li> </ol>   |
| Unit Drive Belt Squeals When Brake Is Applied             | <ol style="list-style-type: none"> <li>1. Check lawn tractor drive belt adjustment and lawn tractor brake adjustment per manual. Adjust if necessary.</li> <li>2. Check for and remove any foreign objects obstructing clutching idler mechanism.</li> </ol>  |
| Unit Drive Belt Comes Off During Use                      | <ol style="list-style-type: none"> <li>1. Check belt tension. Adjust if necessary.</li> <li>2. Check belt guides. Adjust if necessary.</li> <li>3. Check for split or damaged pulley(s). Replace if necessary.</li> <li>4. Check clutching idler pulley alignment. If out of alignment, idler bracket may be bent. Replace if necessary.</li> </ol>   |
| Unit Will Not Propel Itself When Clutch Is Engaged        | <ol style="list-style-type: none"> <li>1. See <b>Steps 1 through 5</b> in <b>Unit Drive Belt Slips</b> section of this chart.</li> <li>2. Check engine, transmission or transaxle pulley(s) for sheared or missing key. Replace if necessary.</li> <li>3. Check transaxle to make certain it is operable.</li> </ol>  |
| Extreme Vibration Occurs When Clutch Is Engaged (Let-Out) | <ol style="list-style-type: none"> <li>1. Check for split or damaged pulley(s). Replace if necessary.</li> <li>2. Check belt for irregularities or burned spots. Replace if necessary.</li> <li>3. Make certain belt tension is correct. Adjust if necessary.</li> <li>4. Check clutching idler assembly for wear or damage. Replace parts as necessary.</li> </ol>   |
| Unit Will Not Shift or Shifts Hard                        | <ol style="list-style-type: none"> <li>1. Check shifting procedure. Unit <b>MUST</b> come to a complete stop before shifting on all models except Shift-on-the-Go and Hydrostatic.</li> <li>2. Check lawn tractor drive belt adjustment and lawn tractor brake adjustment per manual. Adjust if necessary.</li> <li>3. Have transaxle checked by an authorized service dealer.</li> </ol>   |
| Steering Slips Or Is Loose                                | <ol style="list-style-type: none"> <li>1. Check for steering sector gear and pinion looseness. If gears are loose, make sector gear adjustment.</li> <li>2. Check ball joints for wear. Replace if necessary.</li> </ol>  |
| Engine Will Not Turn Over                                 | <ol style="list-style-type: none"> <li>1. Check starting procedure. Make sure starting instructions are followed.</li> <li>2. Check fuse (if so equipped) (See wiring Schematic and diagram in <b>Repair Parts</b> section/manual).</li> <li>3. Check battery for charge. Make sure battery has been activated and charged (on new units).</li> <li>4. On new units, remove spark plug and check cylinder for accumulation of oil due to improper handling.</li> <li>5. Make visual check of electrical system to make sure all connections and lockout switches are secure. (See wiring Schematic and diagram in <b>Repair Parts</b> section/manual)</li> <li>6. Check engine according to engine manufacturer's instructions.</li> <li>7. Have electrical system checked by an authorized service dealer. (See wiring Schematic and diagram in <b>Repair Parts</b> section/manual)</li> </ol> |
| Engine Turns Over But Will Not Start                      | <ol style="list-style-type: none"> <li>1. Check starting procedure. Make sure starting instructions are followed.</li> <li>2. Make certain fuel tank is filled with clean, fresh gasoline.</li> <li>3. Make certain fuel shut-off is open (if so equipped).</li> <li>4. Make certain that throttle is in start or fast position (check for remote choke use).</li> <li>5. Check engine according to engine manufacturer's instructions.</li> <li>6. Have wiring and lockout switches checked by an authorized service dealer. (See wiring Schematic and diagram in <b>Repair Parts</b> section/manual)</li> <li>7. Check fuel filter for obstructions.</li> </ol>   |

# STORAGE

The tractor should be immediately prepared for storage at the end of the season or if the unit is to be un-used for 30 days or more. **Gasoline, if permitted to stand un-used for extended periods (30 days or more), may develop gummy deposits which can adversely affect the engine carburetor and cause engine malfunction.**



**Never store engine with fuel in tank indoors or poorly ventilated enclosures, where fuel fumes may reach an open flame, spark or pilot light as on a furnace, water heater, clothes dryer, etc.**

**Handle gasoline carefully. It is highly flammable and careless use could result in serious fire damage to your person and/or property.**

**Drain fuel into an approved container outdoors away from open flame.**

**To prepare tractor for storage, proceed as follows:**

1. Clean the tractor thoroughly.
2. Inspect the tractor for worn or damaged parts and tighten all loose screws and nuts.
3. Prepare engine for storage (see **Engine Operating and Maintenance Manual**).
4. Lubricate all points shown in **Lubrication Chart**.
5. Remove battery (see **Battery Removal** paragraph in **Maintenance** section of this manual).
6. Clean battery as instructed in **Battery Maintenance** paragraph in **Maintenance** section of this manual. Fully charge battery. A discharged battery will freeze and may burst. If possible place battery in a cool, dry area. Charge battery overnight every 30 days.
7. Store the tractor in a clean, dry area and cover for additional protection.

A yearly check-up or a tune-up by an authorized service dealer is a good way of insuring that your tractor will provide maximum performance for the next season.

**NOTE:** Fuel stabilizer is an acceptable alternative in minimizing the formation of fuel gum deposits during storage. Add stabilizer to gasoline in fuel tank or storage container. Always follow the mix ratio found in stabilizer container. Run engine at least 10 minutes after adding stabilizer to allow the stabilizer to reach the carburetor. Do not drain the gas tank and carburetor if using stabilizer.

# SLOPE GUIDE FOR RIDING MOWERS

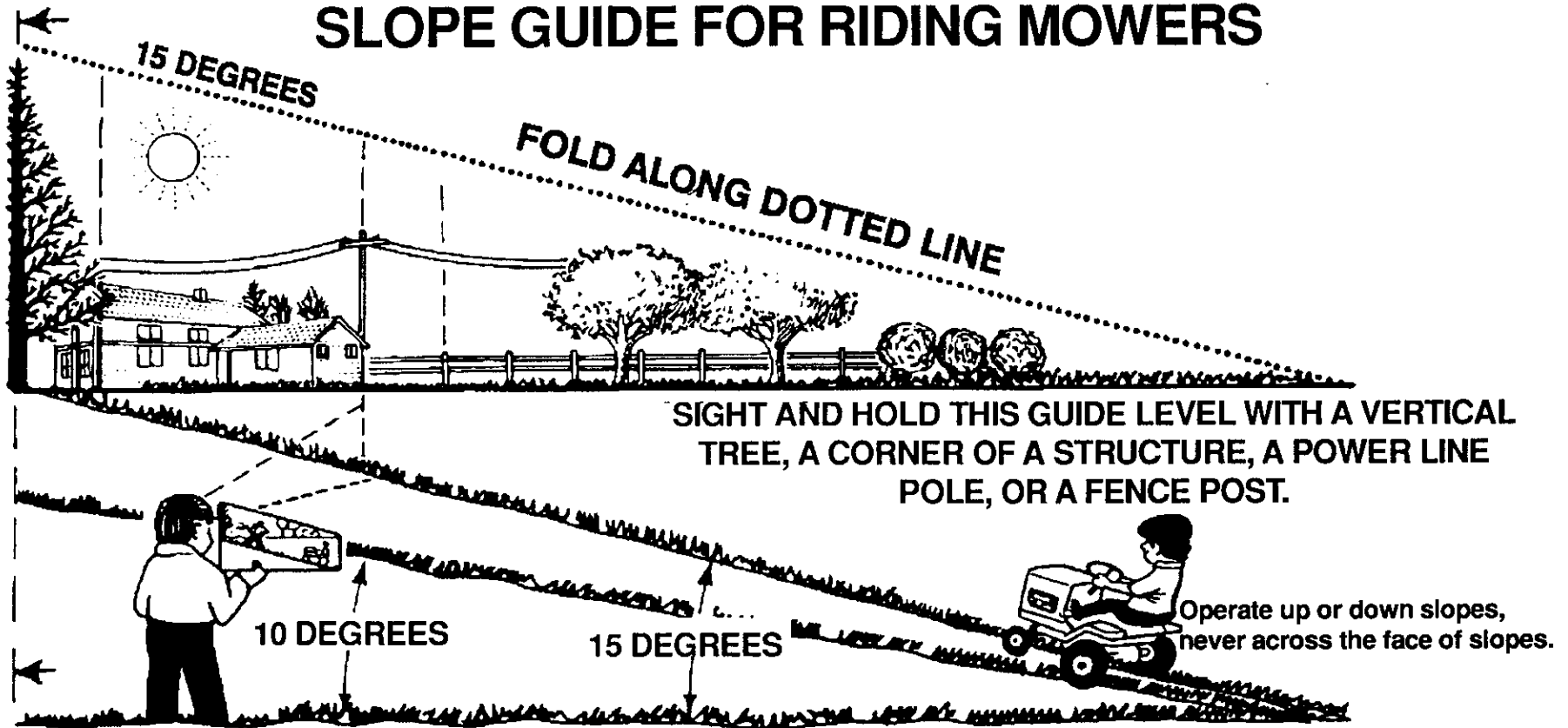

32

To determine if a slope is safe to mow: (1) disengage the blade(s), (2) put the unit in reverse, and (3) try to back straight up the slope. If you can back up the slope, it is generally safe to mow. However, if you do not feel safe, or if you are not completely sure, use this guide and do not mow a slope that is greater than 15 degrees. If the riding mower is used with a pull-behind attachment, do not operate the unit on a slope that is greater than 10 degrees.

A 15 degree slope is a hill that increases in height at approximately 2.5 feet in 10 feet.

A 10 degree slope is a hill that increases in height at approximately 1.7 feet in 10 feet.



Use extreme care at all times, and avoid sudden turns or maneuvers. Follow other instructions in this manual for safety in mowing on slopes. Operate a riding mower up or down slopes, never across the face of slopes. Use extra care when operating on or near slopes and obstructions.

CUT HERE TO USE SLOPE GUIDE









## **MURRAY OUTDOOR PRODUCTS, INC. Two Year Limited Warranty**

**Murray Outdoor Products, Inc.** warrants to the original purchaser that this unit shall be free from defects in material and workmanship under normal use and service for a period of **Two (2) Years** from the date of purchase: however, this warranty does not cover engines, accessories (**such as snow blowers, snow blades, grass catchers and plows**), transmissions, batteries and Normal Wear Parts (**except as noted below**) or transaxles as the companies that manufacture these items furnish their own warranties and provide service through their authorized field service facilities. For additional information, see the warranties covering these particular parts. If you are uncertain whether your unit contains or is equipped with one or more of these parts, consult your dealer prior to purchase. Subject to the terms and conditions noted in this Limited Warranty, we shall, at our option, repair or replace at no cost to the original purchaser any part covered by this Limited Warranty during the applicable warranty period.

In the event the battery proves defective within ninety (**90**) days from the date of purchase, we will replace it without charge. If the battery proves defective after (**90**) days but within one hundred twenty (**120**) days from the date of purchase, we will replace it for a charge of one half (**1/2**) of the retail price of the battery in effect at the time of return.

Normal Wear Parts are defined as belts, blades, blade adapters, pneumatic tires, headlights and seat covers. These parts are warranted to be free from defects in material and workmanship as delivered with the product. Any claim for repair or replacement of Normal Wear Parts must be made within thirty (**30**) days of the date of purchase. No claims involving damage caused from material use, abuse or misuse will be honored.

This **Murray Outdoor Products, Inc. Two (2) Year Limited Warranty** is your exclusive remedy; however, this warranty is void or does not apply to any unit that has been tampered with, altered, misused, abused or used for rental or other commercial and/or professional (**non-homeowner**) uses. Your warranty does not cover minor mechanical adjustments which are not due to any defect in material workmanship. For assistance in making such adjustments, consult your Owner's/Operator's Manual.

To make a claim under this **Murray Outdoor Products, Inc. Two (2) Year Limited Warranty**, return the unit (**or if authorized in advance, the defective part**) along with your proof of purchase to an Authorized Service Center near you. To locate the nearest Authorized Service Center, call the Central Parts Distributor for your area shown in the list provided with your unit or check the Yellow Page listings in your local telephone directory. If you return the entire unit, we will repair the unit. If we authorize the return of the defective part only, we will either replace or repair the part. In the case of a defect in a transmission differential (**as distinguished from a transaxle**), the entire transmission or differential must be returned since they do not include user serviceable parts.

This **Murray Outdoor Products, Inc. Two (2) Year Limited Warranty** gives you specific legal rights, and you may also have other rights which vary from state to state. **This Limited Warranty is given in lieu of all other expressed and implied warranties including the implied warranty of merchantability and warranty of fitness for a particular purpose.** If you need additional information on this written warranty or assistance in obtaining service, write or call:

**MURRAY**  
**Outdoor Power Equipment**  
Customer Service Department  
PO Box 8000  
Jackson, Tennessee 38308  
1-800-247-7464