

Split System Indoor Coils

Installation Instructions

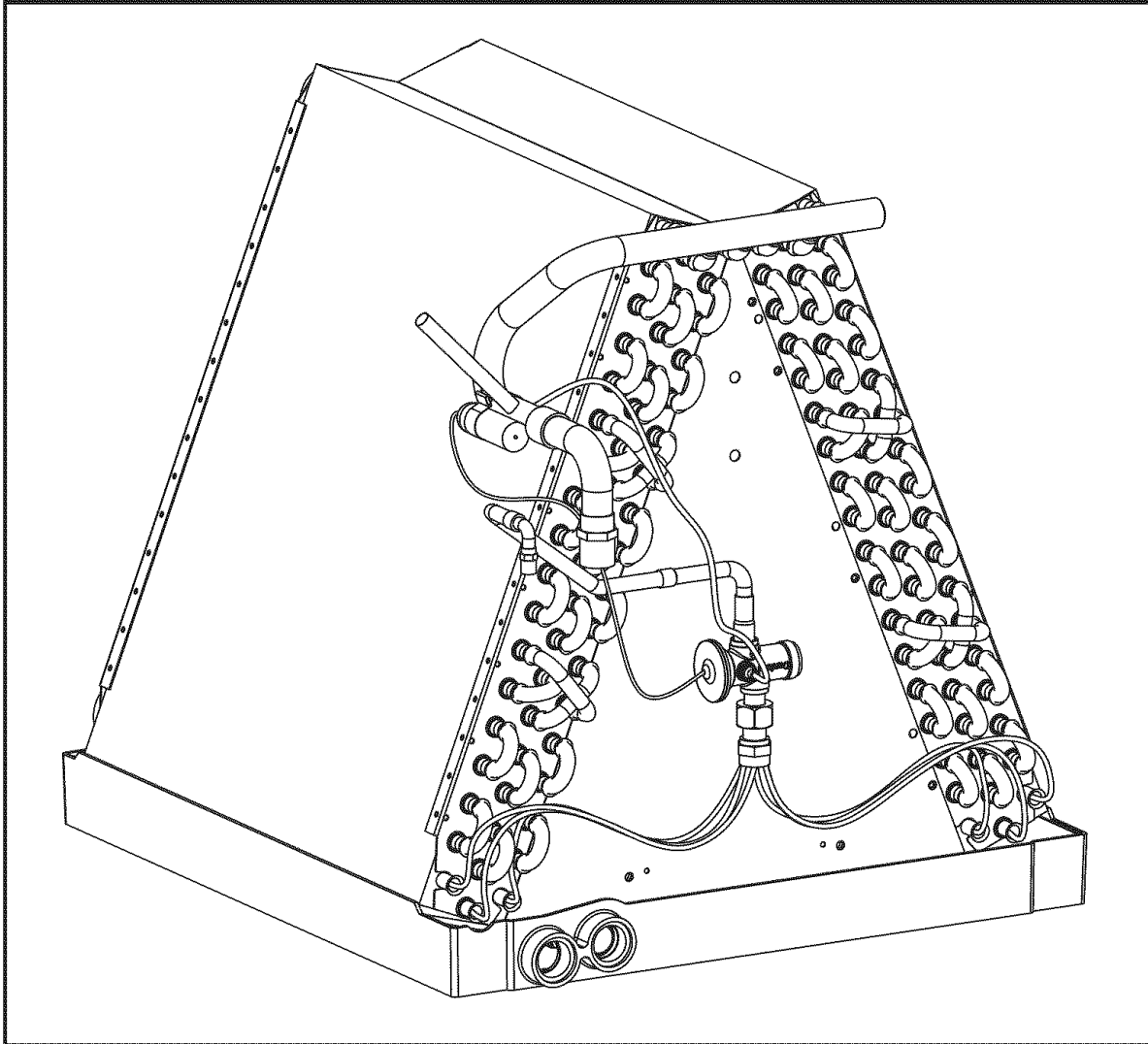

⚠ CAUTION:

Read the installation instructions supplied with the furnace/air handler and observe all safety requirements outlined in the instructions and/or furnace/air handler markings before proceeding with the installation of the coil.

These instructions are primarily intended to assist qualified individuals experienced in the proper installation of this appliance. Some local and national codes require licensed installation/service personnel for this type of equipment. Read all instructions carefully before starting the installation.

Table of Contents

1. General Information	3
2. Coil Specifications	3
3. Coil Installation.....	4
• Upflow Furnace/Air Handler	
• Downflow Electric Furnace	
• Downflow Electric Furnace/Air Handler with Integral Coil Cabinet or Optional Coil Cabinet	
4. Refrigerant Line Connections	6
5. Restrictor Change-Out.....	7
6. Completing the Installation	7
• Condensate Drain	
• Air Filters	
• Close-off Plates and Panels	
• Refrigerant Charging	
7. Maintenance and Service	8

1. GENERAL INFORMATION

C(*)QA/DA coils are designed for upflow and downflow furnace/air handler applications. The C(*)QA coils incorporate "single shot" coupling refrigerant connections for easy installation. The C(*)DA coils are furnished with down-turned refrigerant connections, ready for brazing.

Read the installation manual supplied with the outdoor unit for refrigerant line connection procedure, required line sizes, and other information pertaining to the system installation.

1. Make certain that the air delivery of the furnace/air handler is adequate to handle the static pressure drop of the coil, filter, and duct work.
2. In orifice style models check the orifice size of the coil's expansion device and confirm that it is suitable for application with the intended outdoor unit.
3. Where precise forming of the refrigerant lines is required, a copper tubing bender designed for the size lines used is recom-

mended. Avoid sharp bends and contact of the refrigerant lines with metal surfaces.

4. Refrigerant lines should be wrapped with pressure sensitive neoprene or other suitable material where they pass through the raw edges of holes.
5. The coil enclosure (if provided) and suction line must be insulated as needed to prevent condensate from forming and causing property damage.
6. Coil must be level for proper condensate drainage.
7. Do not remove seals from the coil until the tubing connections are ready to be made.

NOTE: Optional cooling/heating equipment must be properly sized and installed in accordance with the furnace manufacturer's specifications and approved recommendations. "Heating only" furnace air circulators may have to be replaced with multi-speed "Heating/Cooling" blowers to upgrade the air delivery (CFM) when an add-on coil is installed. Refer to Coil Specifications for recommended CFM and allow for pressure drop across the coil and filters.

2. COIL SPECIFICATIONS

C5(D,Q)A	T25	T30	T36	T37	T41	T43	T47	T48	T49	T60
Nominal (2) Capacity BTUH	24,000	30,000	36,000	36,000	42,000	42,000	48,000	48,000	48,000	60,000
Nominal Airflow CFM	800	1000	1200	1200	1400	1400	1600	1600	1600	2000
Width (in.)	18 1/8	18 1/8	18 1/8	18 1/8	18 1/8	18 1/8	18 1/8	18 1/8	21	21
Height (in.)	20	20	20	20	20	24	20	24	28	28
Depth (in.)	19 1/2	19 1/2	19 1/2	19 1/2	19 1/2	19 1/2	19 1/2	19 1/2	19 1/2	19 1/2
Connections										
Liquid Line	3/8	3/8	3/8	3/8	3/8	3/8	3/8	3/8	3/8	3/8
Suction Line	3/4	3/4	3/4	3/4	3/4	3/4	3/4	3/4	3/4	3/4
Metering Device	TXV	TXV	TXV	TXV	TXV	TXV	TXV	TXV	TXV	TXV

C3(D,Q)A	036	047	048	055
Nominal (2) Capacity BTUH	36,000	47,000	48,000	54,000
Nominal Airflow CFM	1,200	1,400	1,500	1,600
Width (in.) W	18 1/8	18 1/8	18 1/8	18 1/8
Height (in.) H	20	20	24 1/4	20
Depth (in.) D	19 1/2	19 1/2	19 1/2	19 1/2
Connections				
Liquid Line	3/8	3/8	3/8	3/8
Suction Line	3/4	3/4	3/4	3/4
Installed Orifice Size (in.)	0.067	0.080	0.082	0.093
Extra Orifice (in.) supplied	0.060 (use for 024) 0.063 (use for 030)	0.075 (use for 042)	N/A	N/A

1. Refer to sales specification sheets for Listed/Certified combinations of equipment and required accessories.
2. Refer to the current ARI Directory for certified ratings of split systems.

3. COIL INSTALLATION

! WARNING:

Electric furnaces may be connected to more than one supply circuit.

Upflow Furnace:

1. Disconnect all electrical power to the furnace.
2. Install the coil in the coil cabinet and level it as needed to allow proper condensate drainage or make a plenum to enclose the coil or drop the duct directly over it.
3. Seal the enclosure as required to minimize air leakage.
4. Connect the refrigerant lines as outlined in the Refrigerant Lines section.

Downflow FE/E* Electric Furnace:

1. Ensure that all electrical power to the furnace is off.
2. Use the appropriate Coil Conversion Kit which includes 2 air filters, close-off plates (2 sets) and a coil hold down bracket.
3. Remove the filter located at the top of the furnace cabinet.
4. Remove the refrigerant line knockouts located at the top and bottom of the furnace cabinet.
5. Install the coil and level it as needed to ensure proper condensate drainage.
6. Secure the coil hold down bracket with screws.
7. Add air filters to the sides of the coil.
8. Cut the floor opening for the refrigerant lines and drain line (See Figure 6).
9. Connect the refrigerant lines as outlined in the Refrigerant Line Connection section. Connect the drain line and ensure that there is a water trap in the water line.

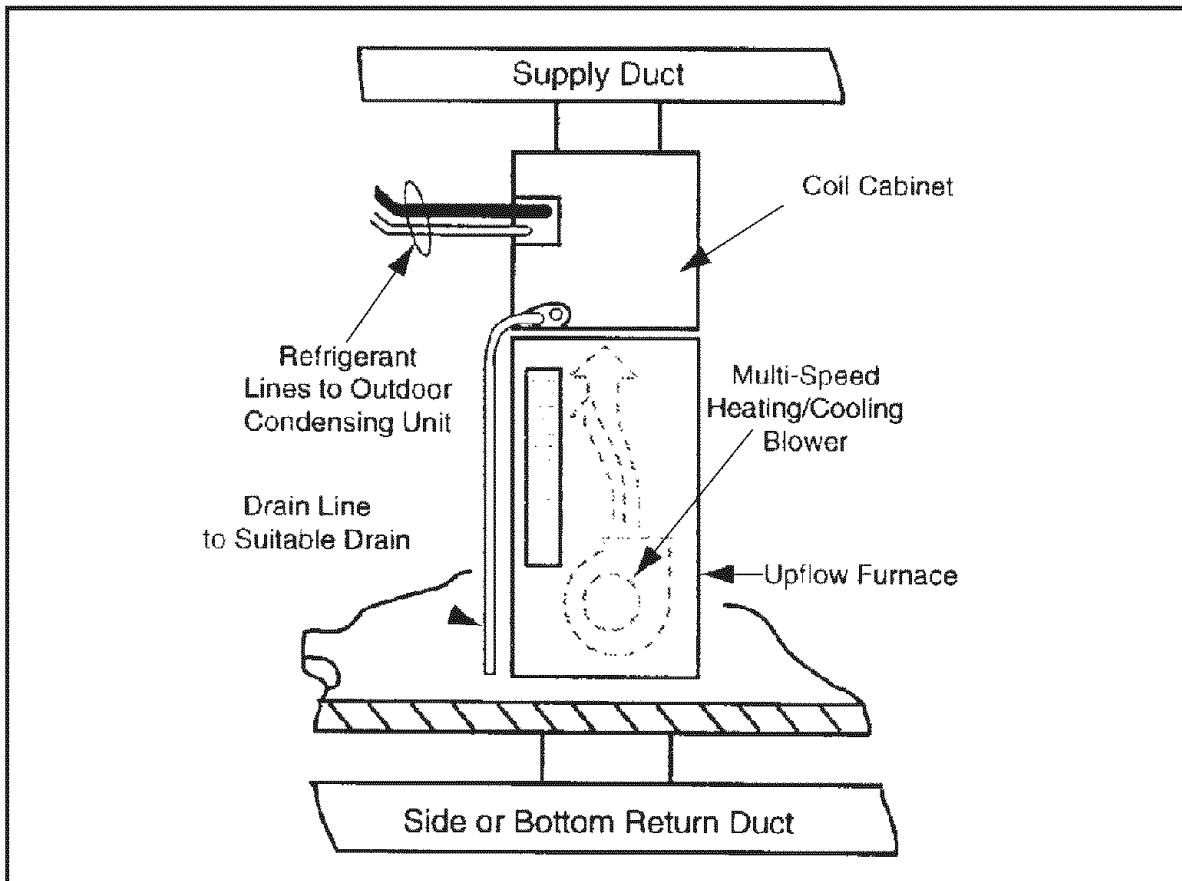

Figure 1. Upflow Furnace/Air Handler

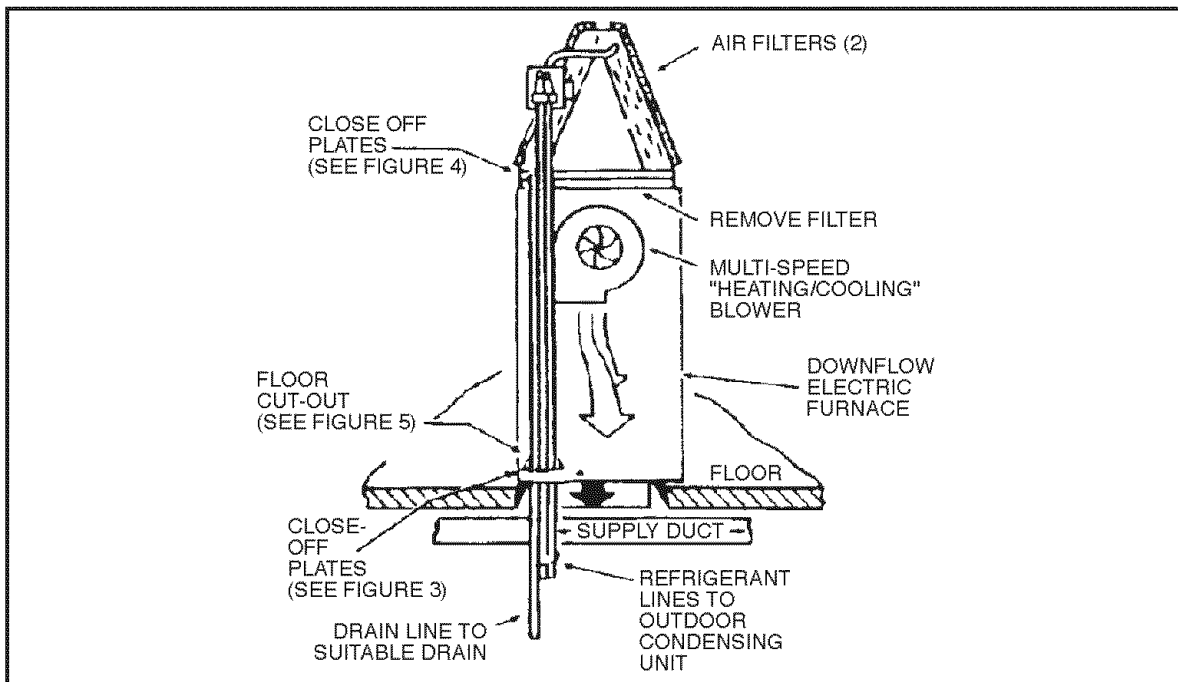

Figure 2. Downflow Furnace without Coil Cabinet

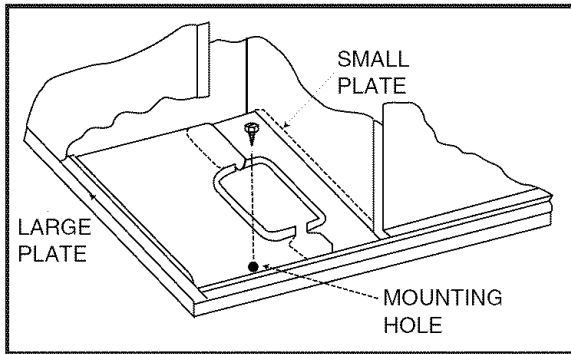

Figure 3. Bottom Close-Off Plates

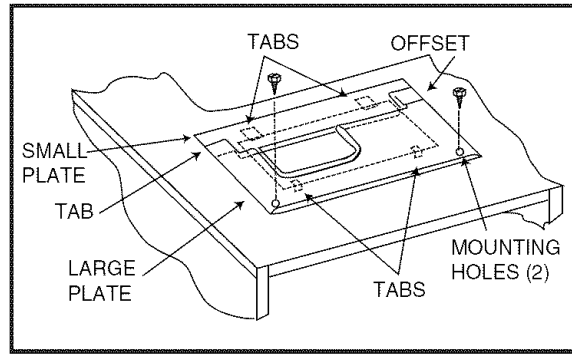

Figure 4. Close-Off Plates for Opening at Top of Furnace

Downflow Furnace with Integral Coil Cabinet or Optional Cabinet

1. Ensure that all electrical power to the furnace is off.
2. On the optional cabinet, refer to its installation instructions for assembly details.
3. Remove the knockout in the left bottom corner of the furnace and cut an appropriately sized hole in the floor. See Figure 6.
4. Remove the interior coil panel. Install the coil and level it as needed to ensure proper condensate drainage.
5. Remove the knockout for the refrigerant lines in the secondary covers and replace in the furnace.

NOTE: Modifications to the panel may be required.

6. Slide the close-off plates around the refrigerant lines and install with the dart clips provided. See Figure 5.

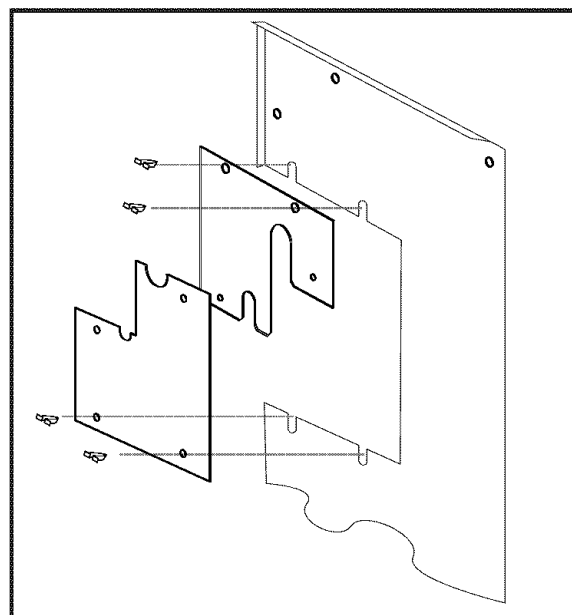

Figure 5. Exploded View for Close-Off Plates

7. Snap the bushings around the lines and into the close-off panels.
8. Connect the refrigerant lines as outlined in the refrigerant lines section.

4. REFRIGERANT LINE CONNECTIONS

CAUTION:

In orifice style coils before proceeding with the connection of the refrigerant lines, confirm that the orifice size meets the requirements outlined in the outdoor unit installation manual.

Factory installed orifice sizes are listed in the Specifications section. If the restrictor orifice must be replaced, see Section 5, Restrictor Change-Out.

1. Remove the protective caps from the coil and refrigerant line set couplings.
2. With a soft, dust-free cloth, carefully wipe clean all coupling threads and seals to remove any dust or material which could contaminate the refrigerant system.
3. Using refrigerant oil, lightly lubricate the diaphragm, seal, and mating threads.
4. Connect the couplings as follows:
 - a.) Line up the refrigerant line with the coil coupling and thread together by hand to ensure proper thread mating. Hold the hex

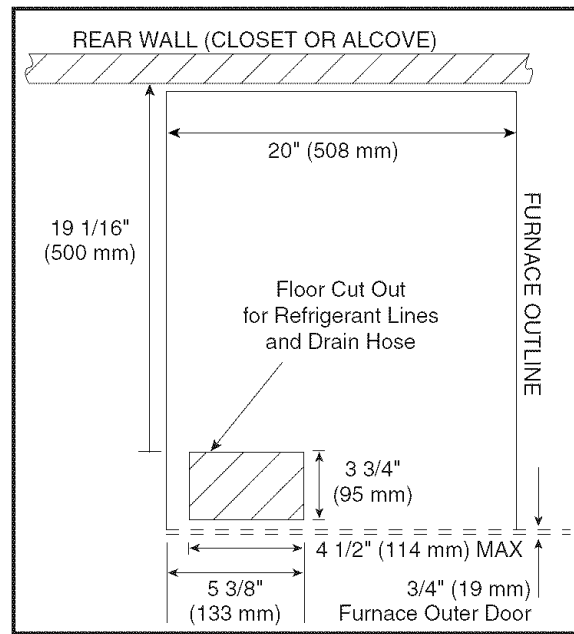

Figure 6. Location of Floor Cut-Out for Refrigerant Lines and Drain Line

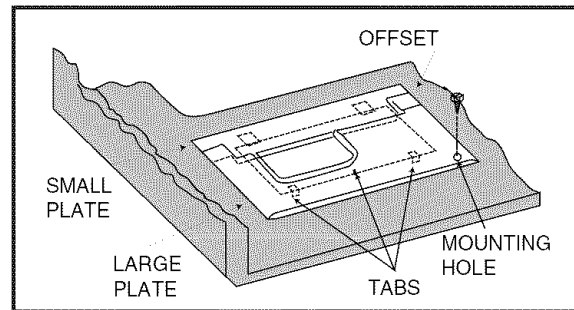

Figure 8. Close-Off Plates (Supplied with appropriate blower conversion package)

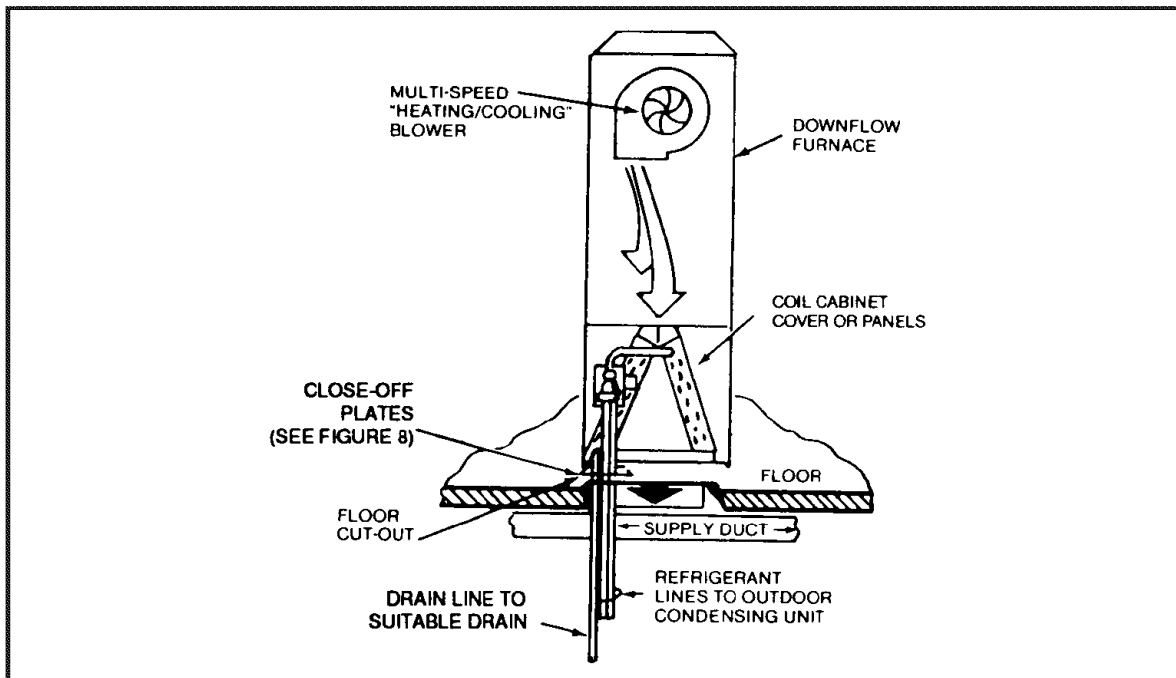

Figure 7. Downflow Furnace with Coil Cabinet

of the male coupling with a wrench and slowly wrench tighten the union nut until a definite resistance (bottoming out) is felt.

b.) Mark the position of the union nut (match lines on the line coupling and the coil coupling), then tighten the coupling an additional 1/4 turn to ensure a leakproof connection. Use the Torque Values table (below) if a torque wrench is used.

5. On C(*)D coils with TXV where brazing is required to make the line connection it is required to wrap a wet rag around the suction tube between the sensing bulb and the joint being brazed to avoid damage to the bulb.
6. Check the system for leaks.

5. RESTRICTOR CHANGE-OUT

NOTE: If the orifice must be replaced, follow these steps.

1. Connect only the suction line coupling to the coil as indicated in Section 4.
2. Reclaim the holding charge from the coil and suction vapor line through the schraeder port using the methods approved under the Refrigerant Transition and Recovery Certification Program.
3. Open the distributor body by using open end wrenches and turning the swivel nut (smaller wrench) counterclockwise. Remove the restrictor, being careful not to scratch the bore or the distributor body (See Figures 9 and 10).
4. Select the proper size restrictor and place it **rounded end down** into the distributor body (See Figure 11).
5. Realign the swivel nut and distributor. Start the threads by hand then continue to tighten with the wrenches until a resistance is felt. Match the position of the nut and then tighten an additional 1/4 turn. If a torque wrench is used, tighten the nut with the values for the 3/8" line.
6. Evacuate the system through the schraeder port on the vapor line.

Torque Values	
Coupling Size	Torque
3/8" (10 mm) Liquid Line Coupling	10 - 12 ft. lbs. 14 - 16 Nm
3/4" (19 mm) or 7/8" (22 mm) Vapor Line Coupling	34 - 45 ft. lbs. 46 - 61 Nm

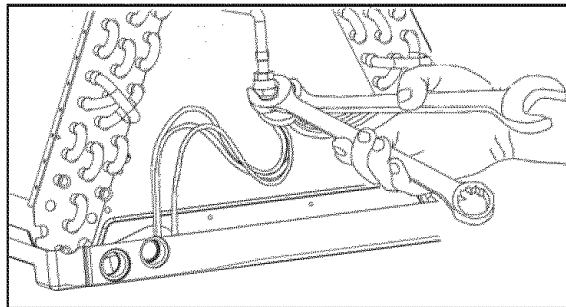

Figure 9. Wrenches on Distributor Body and Assembly Nut

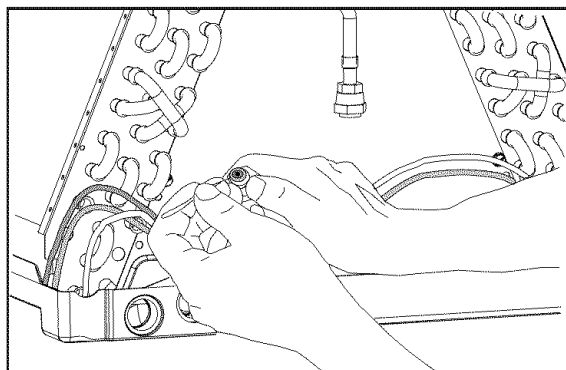

Figure 10. Removal of Orifice

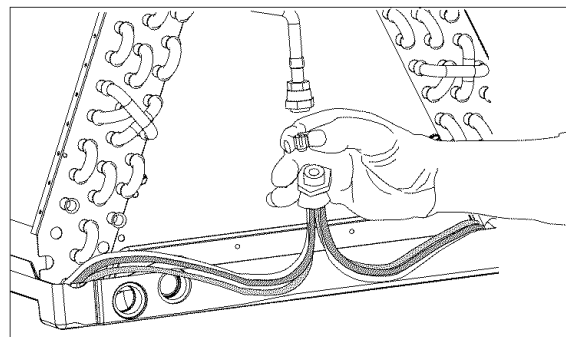

Figure 11. Restrictor Insertion in Distributor Body

7. Connect the liquid line as instructed in Section 4. Check the connections for leaks.

6. COMPLETING THE INSTALLATION



CAUTION:

The indoor coil must be checked to ensure a level installation. Failure to do so may result in improper condensate disposal, causing structural damage, premature equipment failure, or possible personal injury.

Condensate Drain:

1. Thread the 3/4" drain fitting (included) into the lowest tapped hole on the condensate pan. Hand tighten the fitting. If a different configuration is required, use only PVC or similar material for the fitting.
NOTE: Overtightening the fitting may crack the drain pan and create a condensate leak.
2. Slip the drain line over the end of the fitting, add the clamp provided and run to a suitable drain. Avoid bending or pinching of the line.
3. During the system checkout, inspect the drain line and connections to verify proper condensate disposal.

Air Filter — Air filters are not provided as an integral part of this coil, however, a filter must be installed upstream of the coil and inspected frequently. When the filter becomes clogged with dust or lint, it should be replaced (disposable type) or cleaned (washable type). The filter should be inspected and replaced or cleaned at least twice during the year, generally at the start of each heating and cooling season.

Close-Off Plates and Panels — Install the necessary air close-off plates around the refrigerant lines and drain line where required. Reinstall all inner and outer panels of the furnace/air handler that were previously removed to install the indoor coil.

Refrigerant Charging — C(*)Q series indoor coils contain a "holding charge" to prevent entrance of moisture and contaminants during shipment. The total system operating charge of R-22 refrigerant is in the outdoor unit and is adequate for the matched listed system including 15 feet of line set.

WARNING:

Ensure that all electrical power to the furnace and outdoor (condensing) unit is off before performing any maintenance or service on the system.

It will be necessary to evacuate the indoor coil and line set prior to charging. Refer to the outdoor unit installation manual for detailed charging instructions.

7. MAINTENANCE AND SERVICE

To ensure optimum system performance and to minimize the possibility of equipment failure, the following periodic maintenance should be performed on the coil:

1. The air filter installed with the system should be checked and cleaned or replaced twice per year.
2. Check the coil, drain pan, and condensate drain line for cleanliness at the start of each heating and cooling season. Clean and remove any debris as required.

CAUTION:

Do not operate the system without having a suitable filter in place in the return air duct system. Always replace the filter with the same size and type.

INSTALLER: PLEASE LEAVE THESE INSTALLATION INSTRUCTIONS WITH THE HOMEOWNER

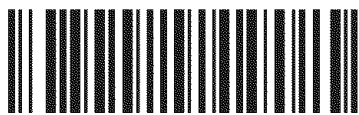

7086350



CERTIFICATION
APPLIES ONLY WHEN
THE COMPLETE
SYSTEM IS LISTED
WITH ARI

