

Data Sheet – JN5148-001-Myy

IEEE802.15.4/ZigBee Module Family

Overview

The JN5148-001-Myy family is a range of ultra low power, high performance surface mount modules targeted at ZigBee PRO networking applications, enabling users to realise products with minimum time to market and at the lowest cost. They remove the need for expensive and lengthy development of custom RF board designs and test suites. The modules use Jennic's JN5148 wireless microcontroller to provide a comprehensive solution with large memory, high CPU and radio performance and all RF components included. All that is required to develop and manufacture wireless control or sensing products is to connect a power supply and peripherals such as switches, actuators and sensors, considerably simplifying product development.

Three module variants are available: JN5148-001-M00 with an integrated antenna, JN5148-001-M03 with an antenna connector and the JN5148-001-M04 with an antenna connector, power amplifier and LNA for extended range. The modules can implement networking stacks such as ZigBee PRO as well as customer applications

Module Block Diagram

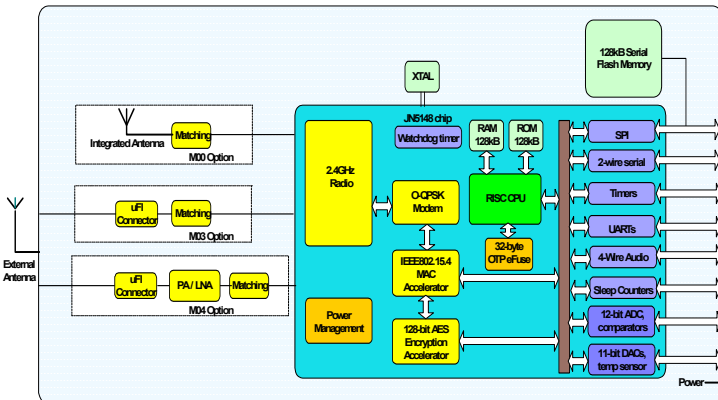

Benefits

- Microminiature module solutions
- Ready to use in products
- Minimises product development time
- No RF test required for systems
- Compliant with FCC part 15 rules, IC Canada RSS 210e, ETSI ETS 300-328 and Japan ARIB STD-T66
- Production volumes supplied pre-programmed with application software

Applications

- Robust and secure low power wireless applications
- ZigBee PRO networks
- Home and commercial building automation
- Utilities metering (e.g. AMR)
- Location Aware services (e.g. Asset Tracking)
- Toys and gaming peripherals
- Industrial systems
- Telemetry
- Remote Control

Features: Module

- 2.4GHz IEEE802.15.4 & ZigBee compatible
- Sleep current (with active sleep timer) 2.6µA
- **JN5148-001-M00/03**
 - up to 1km range (Ext antenna)
 - M00: integral antenna 18x32mm
 - M03: uFI connector 18x30mm
 - TX power +2.5dBm
 - Receiver sensitivity -95dBm
 - TX current 15mA
 - RX current 17.5mA
 - 2.3-3.6V operation
- **JN5148-001-M04**
 - up to 4km range (Ext Antenna)
 - 20dBm TX power
 - Receiver sensitivity -98dBm
 - uFI connector
 - TX current 110mA
 - RX current 23mA
 - 18x41mm
 - 2.7-3.6V operation

Features: Microcontroller

- 32-bit RISC CPU, up to 32MIPs with low power
- 128KB ROM stores system code
- 128KB RAM stores system data and bootloaded program code
- 4Mbit serial flash for program code and data
- On chip OTP eFuse
- JTAG debug interface
- 4-input 12-bit ADC, 2 12-bit DACs, 2 comparators
- 3 application timer/counters, 3 system timers
- 2 UARTs
- SPI port with 5 selects
- 2-wire serial interface
- 4-wire digital audio interface
- Watchdog timer
- Up to 21 DIO

Industrial temp (-40°C to +85°C)

Lead-free and RoHS compliant

Contents

1. Introduction	3
1.1. Variants	3
1.2. Regulatory Approvals	3
2. Specifications	4
3. Product Development	5
3.1. JN5148 Single Chip Wireless Microcontroller	5
4. Pin Configurations	6
4.1. Pin Assignment	7
4.2. Pin Descriptions	8
4.2.1 Power Supplies	8
4.2.2 SPI Memory Connections	8
5. Electrical Characteristics	9
5.1. Maximum Ratings	9
5.2. Operating Conditions	9
5.3. Reflow Profile	10
Appendix A Additional Information	11
A.1 Outline Drawing	11
A.2 Module PCB Footprint	14
A.3 Ordering Information	15
A.4 Tape and Reel Information:	16
A.4.1 Tape Orientation and dimensions	16
A.4.2 Cover tape details	16
A.4.3 Leader and Trailer	17
A.4.4 Reel Dimensions:	17
A.5 Related Documents	17
A.6 Federal Communication Commission Interference Statement	18
A.6.1 Antennas to be approved by FCC for use with JN5148 modules	19
A.6.2 High Power Module usage limitation	20
A.6.3 High Power Module channel restriction	20
A.6.4 FCC End Product Labelling	20
A.7 Industry Canada Statement	20
A.7.1 Industry Canada End Product Labelling	20
A.8 European R & TTE Directive 1999/5/EC Statement	20
A.9 RoHS Compliance	21
A.10 Status Information	21
A.11 Disclaimers	22
A.12 Version Control	23

1. Introduction

The JN5148-001-Myy module family provides designers with a ready made component which allows IEEE802.15.4 [1] wireless applications, using Jennic’s JenNet networking protocol or ZigBee PRO, to be quickly and easily included in product designs. The modules integrate all of the RF components required, removing the need to perform expensive RF design and test. Products can be designed by simply connecting sensors and switches to the module IO pins. The modules use Jennic’s single chip IEEE802.15.4 Wireless Microcontroller, allowing designers to make use of the extensive chip development support material. Hence, this range of modules allows designers to bring wireless applications to market in the minimum time with significantly reduced development effort and cost.

Three variants are available: JN5148-001-M00 (standard module with integral antenna), JN5148-001-M03 (standard module with uFI connector for use with external antennae) and JN5148-001-M04 (high RF power with uFL connector, improved sensitivity module for evaluation of extended range applications). All modules will have FCC modular approvals and be compliant with EU regulations. The variants available are described below.

1.1. Variants

Variant	Description	FCCID
JN5148-001-M00	Standard Power, integrated antenna	TYOJN5148M0
JN5148-001-M03	Standard Power, uFI connector	TYOJN5148M3
JN5148-001-M04	High Power, uFI connector	TYOJN5148M4

1.2. Regulatory Approvals

All module types will be tested against the requirements of European standard ETS 300 328 v1.7.1 and a Notified Body statement of opinion for this standard is available on request. The High Power module with M04 suffix will be approved for use in Europe with reduced output power: +10dBm EIRP is the maximum permitted in Europe.

Additionally, modules with M00, M03 and M04 suffixes will have received FCC “Modular Approvals”, in compliance with CFR 47 FCC part 15 regulations and in accordance to FCC Public notice DA00-1407. The modules are approved for use with a number of antennas; refer to section Appendix A.6.1 for details. See Appendix A.6 for details on the conditions applying to this modular approval. The modular approvals notice and test reports are available on request.

The high power module variant is classified as ‘mobile’ device pursuant with FCC § 2.1091 and must not be used at a distance of less than 20 cm (8”) from any person.

In addition, all modules will have Industry Canada RSS210e Issue 7 (June 2007) certification.

2. Specifications

Most specification parameters for the modules are specified in the chip datasheet - JN-DS- JN5148 Wireless Microcontroller Datasheet, [2]. Where there are differences, the parameters are defined here.

VDD=3.0V @ +25°C

Typical DC Characteristics			Notes
	JN5148-001-M00/03	JN5148-001-M04	
Deep sleep current	1.3uA	1.3uA	
Sleep current	2.6uA	2.6uA	With active sleep timer
Radio transmit current	15mA	110mA	CPU in doze, radio transmitting
Radio receive current	17.5mA	23mA	CPU in doze, radio receiving
Centre frequency accuracy	+/-25ppm	+/-25ppm	Additional +/-15ppm allowance for temperature and ageing
Typical RF Characteristics			Notes
Receive sensitivity	-95dBm	-98dBm	Nominal for 1% PER, as per 802.15.4 section 6.5.3.3 (Note 1)
Maximum Transmit power	+2.5dBm	18dBm	Nominal (Note 1)
Transmit power at 3.6V		20dBm	With Vdd=3.6V
Maximum input signal	+5dBm	-5dBm	For 1% PER, measured as sensitivity
RSSI range	-95 to -10 dBm	-105 to -20 dBm	
RF Port impedance – uFI connector	50 ohm	50 ohm	2.4 - 2.5GHz
VSWR (max)	2:1	2:1	2.4 - 2.5GHz
Peripherals			Notes
Master SPI port	5 selects	3 selects	250kHz - 16MHz
Slave SPI port	✓	✓	250kHz - 8MHz
Two UARTs	✓	✓	16550 compatible
Two-wire serial I/F (compatible with SMBus & I ² C)	✓	✓	Up to 400kHz
Two programmable Timer/Counters with capture/compare facility, Tick timer	✓	✓	16MHz clock
Two programmable Sleep Timers	✓	✓	32kHz clock
Digital IO lines (multiplexed with UARTs, timers and SPI selects)	21	19	
Four channel Analogue-to-Digital converter	✓	✓	12-bit, up to 100ks/s
Two channel Digital-to-Analogue converter	✓	✓	12-bit, up to 100ks/s
Two programmable analogue comparators	✓	✓	Ultra low power mode for sleep
Internal temperature sensor and battery monitor	✓	✓	

The performance of all peripherals is defined in the JN-DS- JN5148 Wireless Microcontroller Datasheet [2]

Note 1: Sensitivity is defined for conducted measurements on connectorised modules. Modules with an integrated antenna have approximately 4 dB less e.i.r.p and reciprocal receive sensitivity.

3. Product Development

Jennic supplies all the development tools and networking stacks needed to enable end-product development to occur quickly and efficiently. These are all freely available from Jennic's support website: <http://www.jennic.com/support/> . A range of evaluation/developer kits is also available, allowing products to be quickly bread boarded. Efficient development of software applications is enabled by the provision of a complete, unlimited, software developer kit. Together with the available libraries for the IEEE802.15.4 MAC and the ZigBee network stack, this package provides everything required to develop application code and to trial it with hardware representative of the final module.

The modules can be user programmed for both in development and in production using software supplied by Jennic. They can also be supplied ready loaded with customer defined software if required. Access to the on-chip peripherals, MAC and network stack software is provided through specific APIs. This information is available on the Jennic support website, together with many example applications, user guides, reference manuals and application notes.

3.1. JN5148 Single Chip Wireless Microcontroller

The JN5148-001-My series is constructed around the JN5148-001 single chip wireless microcontroller, which includes the radio system, a 32-bit RISC CPU, ROM and RAM memory and a range of analogue and digital peripherals.

The chip is described fully in JN-DS- JN5148 Wireless Microcontroller Datasheet [2].

The module also includes a 4Mbit serial flash memory, which holds the application code that is loaded into the JN5148 during the boot sequence and provides static data storage, required by the application.

4. Pin Configurations

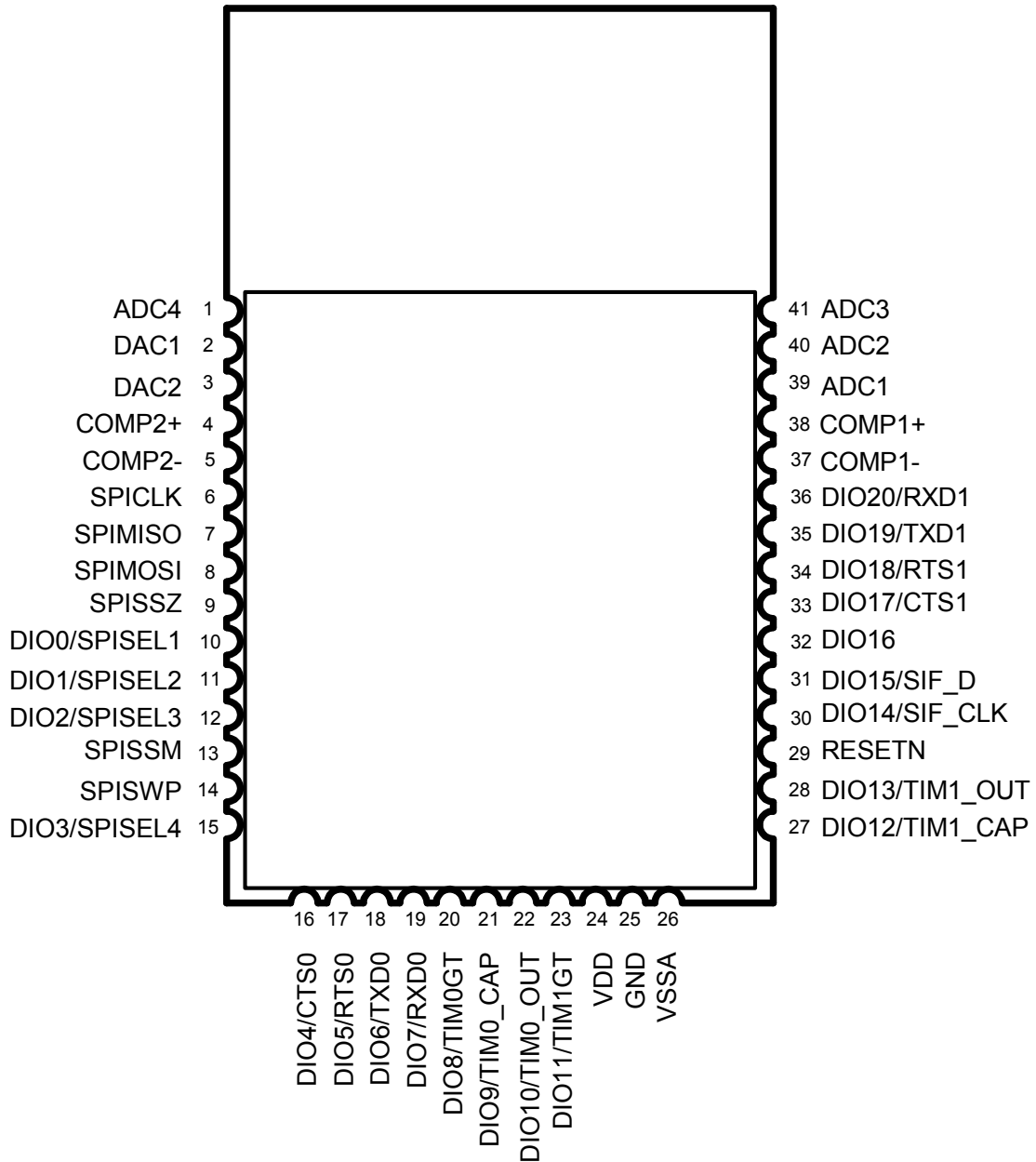

Figure 1: Pin Configuration (top view)

Note that the same basic pin configuration applies for all module designs. However, DIO3/SPISEL4 and DIO2/SPISEL3 are not available on the high power modules.

4.1. Pin Assignment

Pin	Signal	Function	Alternative Function
1	ADC4	Analogue to Digital input	
2	DAC1	Digital to Analogue output	
3	DAC2	Digital to Analogue output	
4	COMP2+	Comparator 2 inputs	
5	COMP2-		
6	SPICLK	SPI master clock out	
7	SPIMISO	SPI Master In/Slave Out	
8	SPIMOSI	SPI Master Out/Slave In	
9	SPISSZ	SPI select from module - SS0 (output)	
10	DIO0/SPISEL1	SPI Slave Select1 (output)	General Purpose Digital I/O DIO0
11	DIO1/SPISEL2	SPI Slave Select2 (output)	General Purpose Digital I/O DIO1
12	DIO2/SPISEL3*	SPI Slave Select3 (output)	General Purpose Digital I/O DIO2 *
13	SPISSM	SPI select to FLASH (input)	
14	SPISWP	FLASH write protect (input)	
15	DIO3/SPISEL4*	SPI Slave Select4 (output)	General Purpose Digital I/O DIO3*
16	DIO4/CTS0	UART0 Clear To Send (input) /TCK (JTAG)	General Purpose Digital I/O DIO4
17	DIO5/RTS0	UART0 Request To Send (output) /TMS(JTAG)	General Purpose Digital I/O DIO5
18	DIO6/TXD0	UART0 Transmit Data (output) /TDO(JTAG)	General Purpose Digital I/O DIO6
19	DIO7/RXD0	UART0 Receive Data (input) / TDI(JTAG)	General Purpose Digital I/O DIO7
20	DIO8/TIM0GT	Timer0 clock/gate (input)	General Purpose Digital I/O DIO8
21	DIO9/TIM0_CAP	Timer0 capture (input)	General Purpose Digital I/O DIO9
22	DIO10/TIM0_OUT	Timer0 PWM (output)	General Purpose Digital I/O DIO10
23	DIO11/TIM1GT	Timer1 clock/gate (input)	General Purpose Digital I/O DIO11
24	VDD	3V power	
25	GND	Digital ground	
26	VSSA	Analogue ground	
27	DIO12/TIM1_CAP	Timer1 capture (input)	General Purpose Digital I/O DIO12
28	DIO13/TIM1_OUT	Timer1 PWM (output)	General Purpose Digital I/O DIO13
29	RESETN	Active low reset	
30	DIO14/SIF_CLK	Serial Interface clock / Intelligent peripheral	General Purpose Digital I/O DIO14

Pin	Signal	Function	Alternative Function
31	DIO15/SIF_D	Serial Interface data / Intelligent Peripheral data output	General Purpose Digital I/O DIO15
32	DIO16	Intelligent Peripheral data in	General Purpose Digital I/O
33	DIO17CTS1	UART1 Clear To Send (input)/ Intelligent Peripheral device select	General Purpose Digital I/O DIO17
34	DIO18/RTS1	UART1 Request To Send (output)/ Intelligent Peripheral Interrupt	General Purpose Digital I/O DIO18
35	DIO19/TXD1	UART1 Transmit Data (output)	General Purpose Digital I/O DIO19
36	DIO20/RXD1	UART1 Receive Data (input)	General Purpose Digital I/O DIO20
37	COMP1-	Comparator 1 inputs	
38	COMP1+		
39	ADC1	Analogue to Digital input	
40	ADC2	Analogue to Digital input	
41	ADC3	Analogue to Digital input	

*: These two pins are not connected for High power modules

4.2. Pin Descriptions

All pins behave as described in the JN-DS- JN5148 Wireless Microcontroller Datasheet [2], with the exception of the following:

4.2.1 Power Supplies

A single power supply pin, VDD is provided. Separate analogue (VSSA) and digital (GND) grounds are provided. These should be connected together at the module pins.

4.2.2 SPI Memory Connections

SPISWP is a write protect pin for the serial flash memory. This should be held low to inhibit writes to the flash device.

SPISSZ is connected to SPI Slave Select 0 on the JN5148.

SPISSM is connected to the Slave Select pin on the memory.

This configuration allows the flash memory device to be programmed using an external SPI programmer if required. For programming in this mode, the JN5148 should be held in reset by taking RESETN low. Two potential flash 4MB memory devices may be used in the module, the Numonyx M25P40 and the SST SST25VF040B.

The memory can also be programmed over the UART by using the flash programmer software provided by Jennic. This is available as part of the Software Developer kit and libraries available from Jennic's support website – www.jennic.com/support. To enter this programming mode, SPIMISO (pin 7) should be held low whilst the chip is reset. Once programming has finished, the chip should be reset, when it will execute the new code downloaded.

For normal operation of the module and programming over the UART, SPISSZ should be connected to SPISSM.

5. Electrical Characteristics

In most cases, the Electrical Characteristics are the same for both module and chip. They are described in detail in the chip datasheet. Where there are differences, they are detailed below.

5.1. Maximum Ratings

Exceeding these conditions will result in damage to the device.

Parameter		Min	Max
Device supply voltage VDD		-0.3V	3.6V
Voltage on analogue pins VREF, ADC1-4, DAC1-2, COMP1M, COMP1P, COMP2M, COMP2P, IBIAS		-0.3V	VDD + 0.3V
Voltage on 5v tolerant digital pins DIO0-DIO8 & DIO11-20, RESETN		-0.3V	Lower of (VDD + 2V) and 5.5V
Voltage on 3v tolerant digital pins DIO9, DIO10, SPISSM, SPISWP, SPICLK, SPIMOSI, SPIMISO, SPISSZ		-0.3V	VDD + 0.3V
Storage temperature		-40°C	150°C
ESD rating	Human Body Model ¹		2.0kV
	Machine Model ²		200V
	Charged Device Model ³		500V

- 1) Testing for Human Body Model discharge is performed as specified in JEDEC Standard JESD22-A114.
- 2) Testing for Machine Model discharge is performed as specified in JEDEC Standard JESD11-A115.
- 3) Testing for Charged Device Model discharge is performed as specified in JEDEC Standard JESD22-C101.

This device is sensitive to ESD and should only be handled using ESD precautions.

5.2. Operating Conditions

Supply	Min	Max
VDD (Module M00/M03)	2.3V	3.6V
VDD (Module M04)	2.7V	3.6V
Ambient temperature range	-40°C	85°C

5.3. Reflow Profile

For reflow soldering, it is recommended to follow the reflow profile in figure 2 as a guide, as well as the paste manufacturers guidelines on peak flow temperature, soak times, time above liquidus and ramp rates.

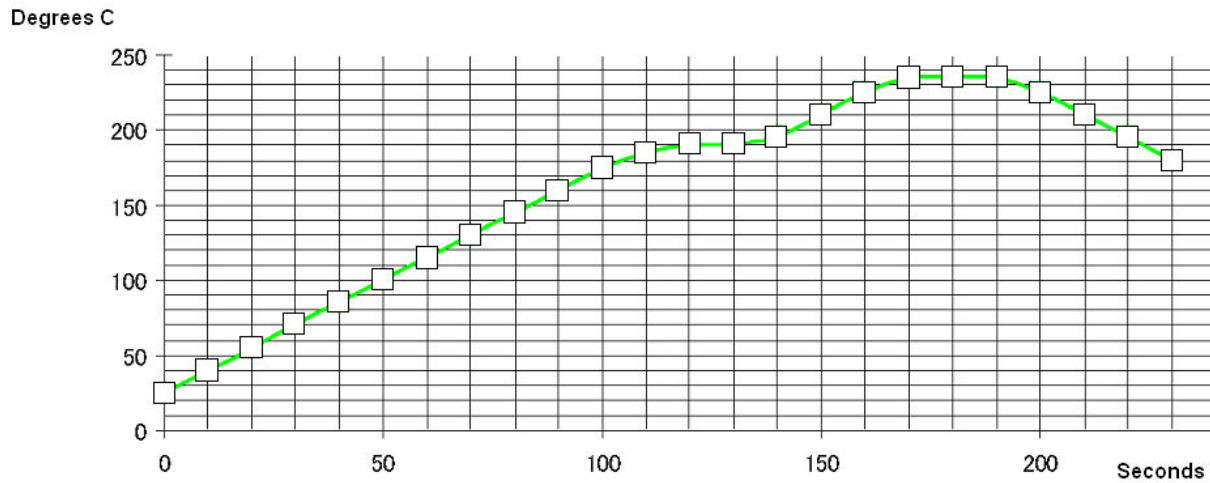

Temperature	25~160 °C	160~190 °C	> 220° C	230~Pk.	Pk. Temp (235°C)
Target Time (s)	90~130	30~60	20~50	10~15	160~270

Figure 2: Recommended solder reflow profile

Appendix A Additional Information

A.1 Outline Drawing

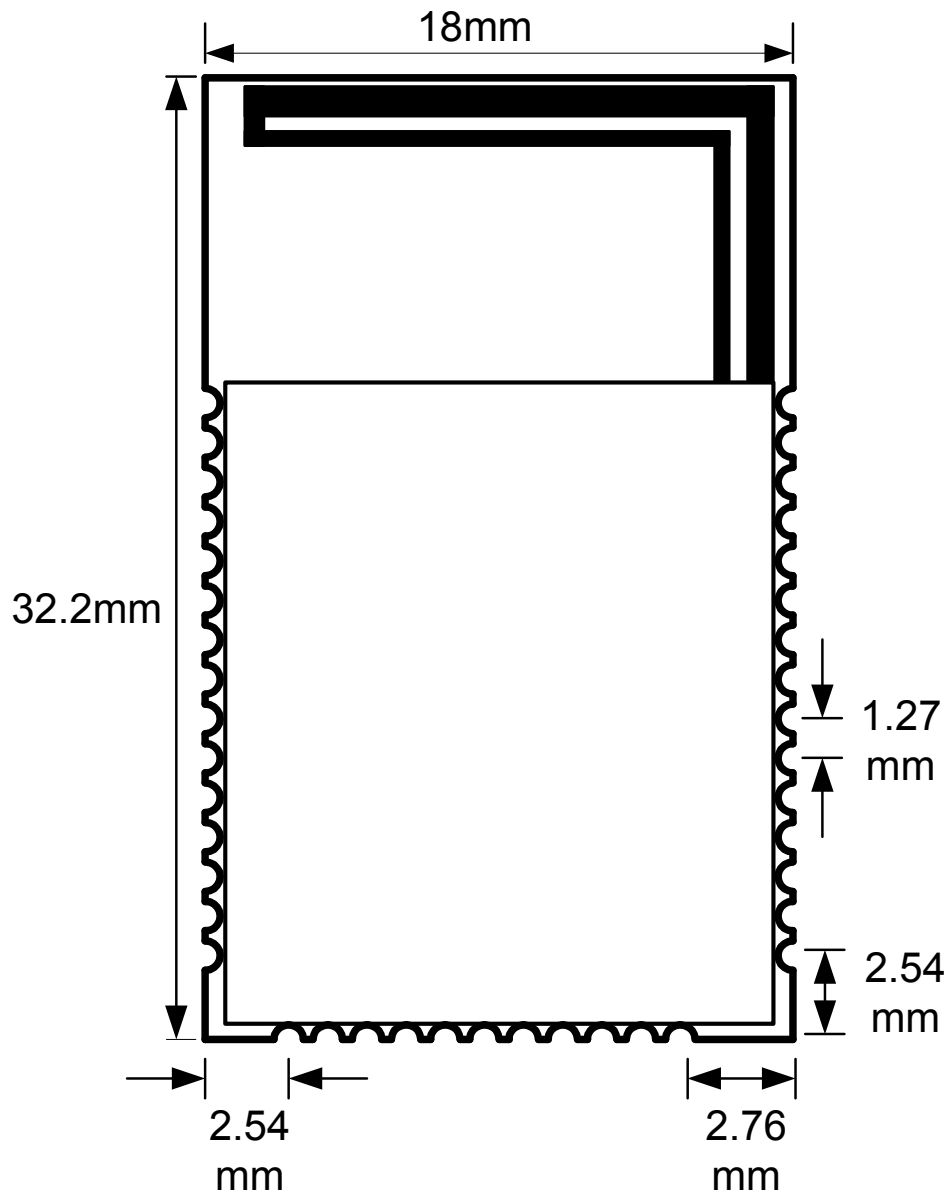

Thickness: 3.5mm

Figure 3 JN5148-001-M00 Outline Drawing

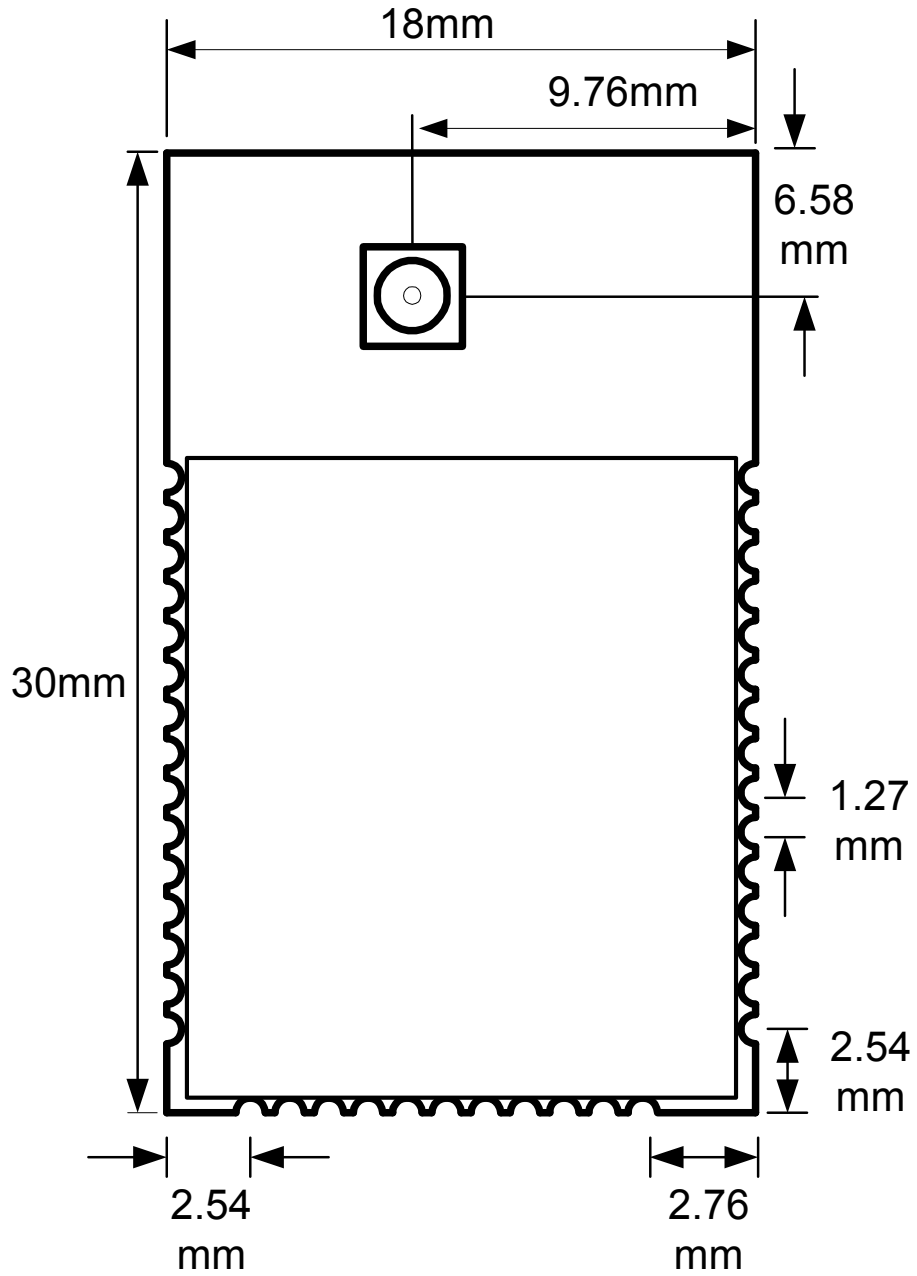

Thickness: 3.5mm

Figure 4 JN5148-001-M03 Outline Drawing

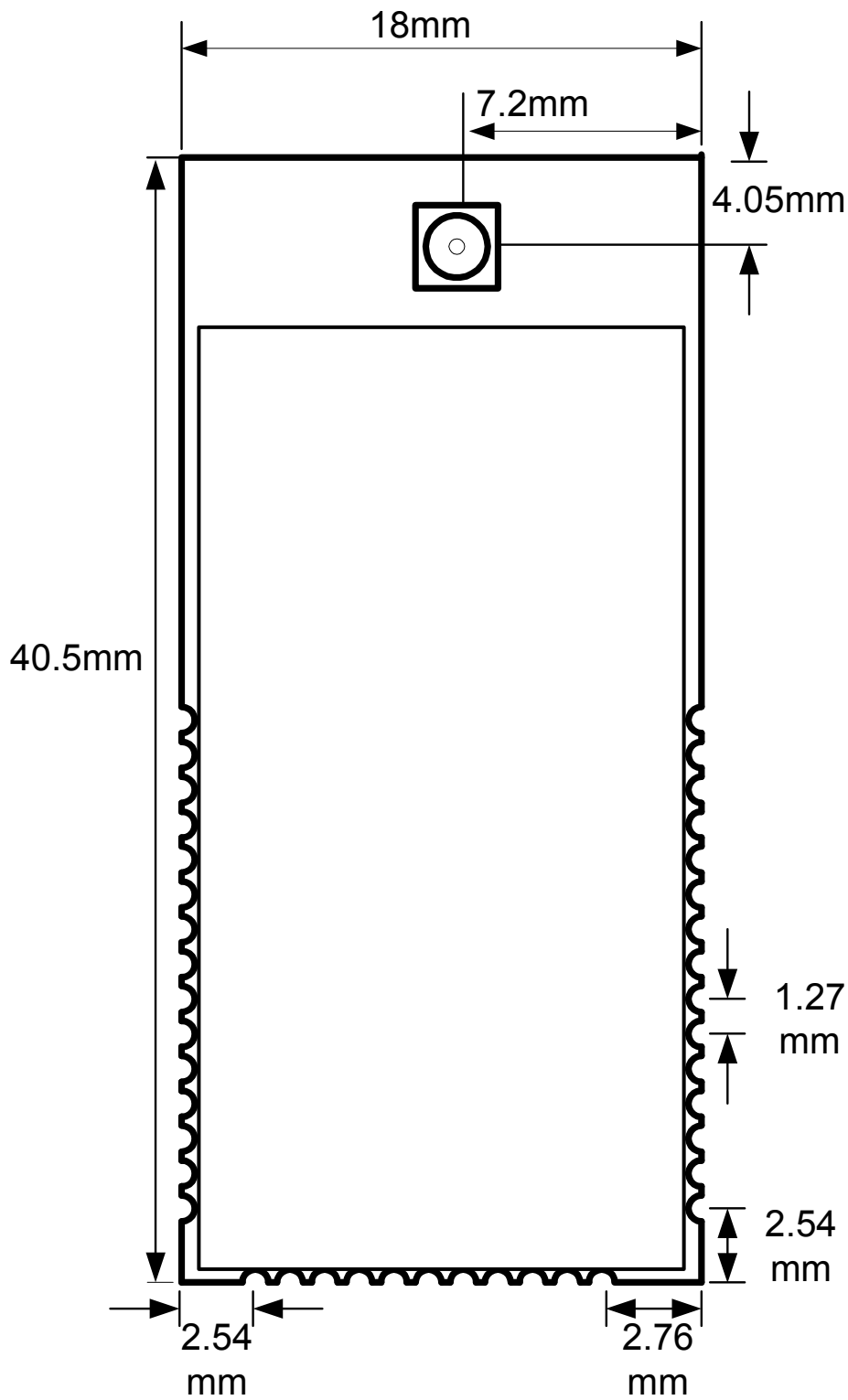

Thickness: 3.5mm

Figure 5 JN5148-001-M04 Outline Drawing

A.2 Module PCB Footprint

All dimensions are in mm.

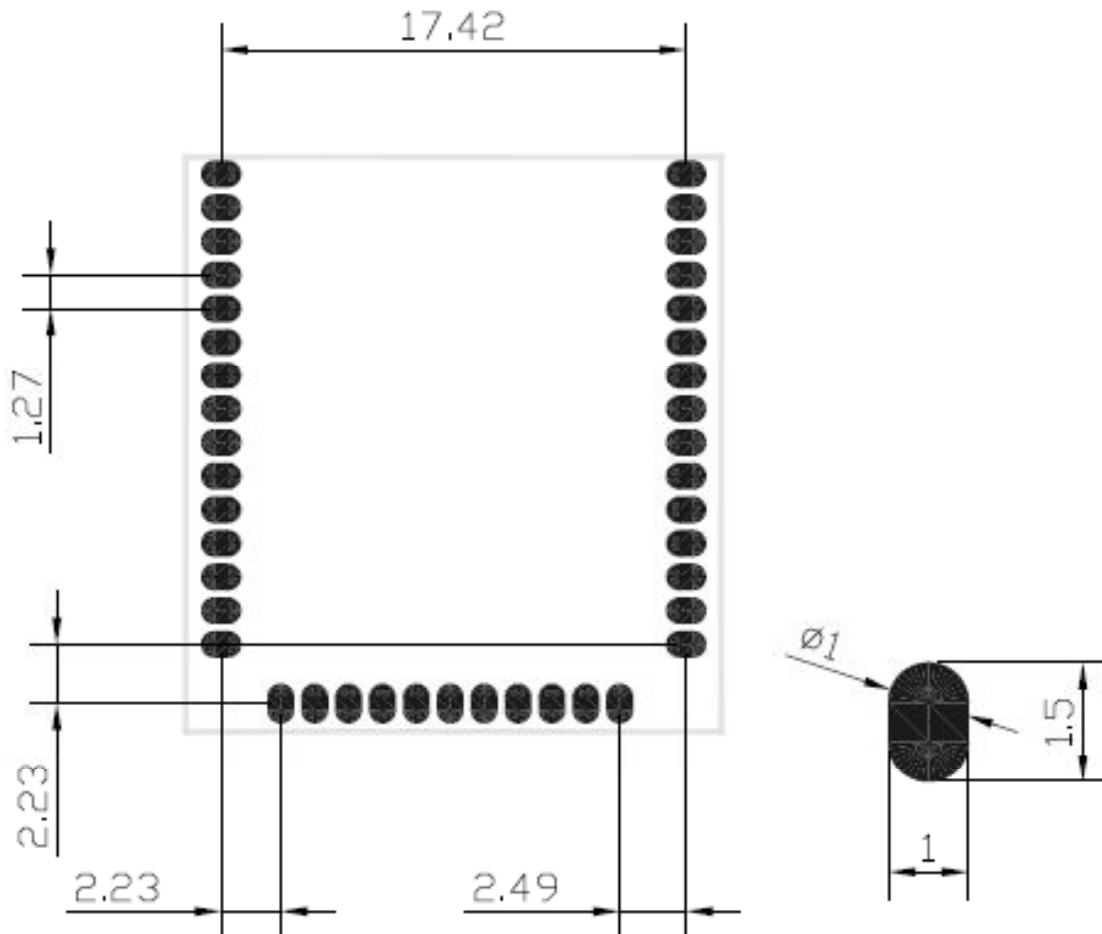

Note: All modules have the same footprint.

Figure 6 Module PCB footprint

RF note for -M00 modules with integral antenna: No components, ground plane or tracks on any layer of the mother board should be placed within 20mm of the 3 free sides of the antenna. Tracks etc may be placed adjacent to the can, but should not extend past the can towards the antenna end of the module for 20mm from the antenna.

A.3 Ordering Information

JN5148 - 001 - MY₁Y₂ Y₃

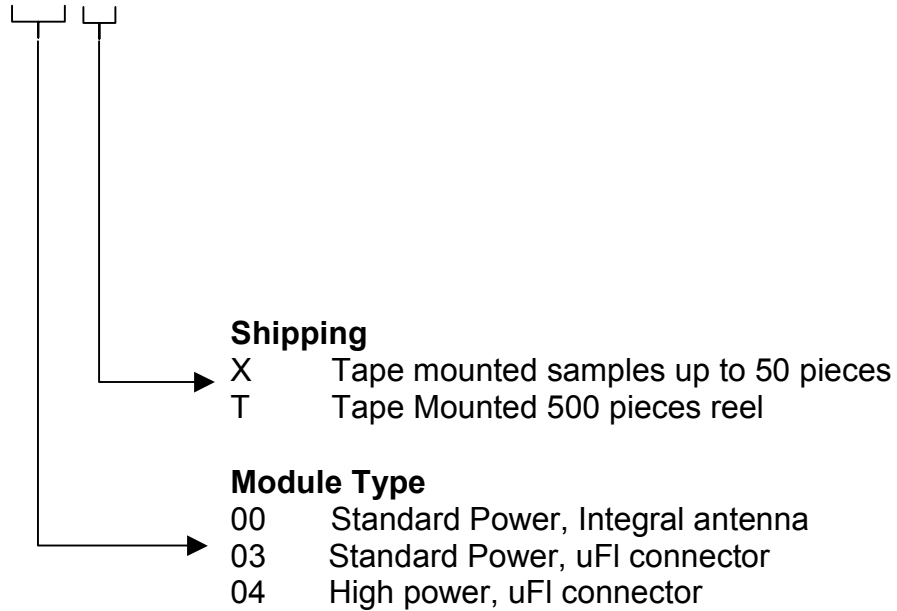

Where this Data Sheet is denoted as “Advanced” or “Preliminary”, devices will be either Engineering Samples or Prototypes. Devices of this status have an Rx suffix after the module type to identify revision of silicon during these product phases - for example JN5148-001-M00R1-T.

- Label line 1: **IC ID Number**
- Label line 2: **FCC ID Number**
- Label line 3: **Part Name**
- Label line 4: **Barcode Label**
- Label line 5: **YYWWTNNNNN (see below)**

Identifier	Description	Format
YY	Year	06(example)
WW	Week	45(example)
T	Module type	
NNNNN	Serial Number	

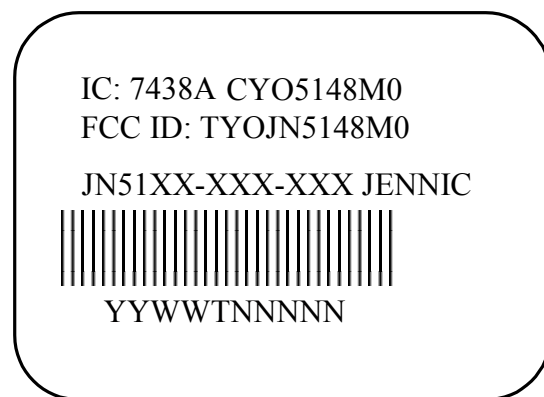
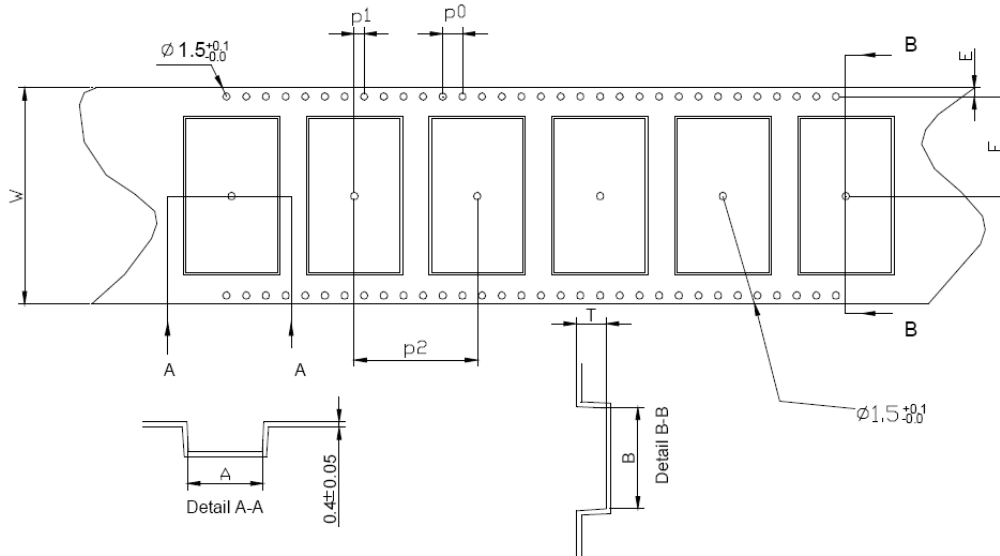

Figure 7: Example module labelling for FCC approved modules

A.4 Tape and Reel Information:

A.4.1 Tape Orientation and dimensions

All dimensions are in mm



Module type:	A	B	W	F	E	P0	P1	P2	T	Cover Tape width (W)
JN5148-001-M00	18.4	32.6	44	20.2	1.75	4.0	2.0	24.0	3.4	37.5
JN5148-001-M03	18.4	30.4	44	20.2	1.75	4.0	2.0	24.0	3.4	37.5
JN5148-001-M04	18.5	40.9	56	26.2	1.75	4.0	2.0	24.0	3.4	49.5
Tolerance	±0.1	±0.1	±0.3	±0.1	+0.1	±0.1	±0.1	±0.1	±0.1	±0.1

A.4.2 Cover tape details

Thickness (T)	0.061mm
Surface resistivity (component side)	10^4 to 10^7 Ohms/sq
Surface resistivity (component side)	Non-conductive
Backing type:	Polyester
Adhesive type:	PSA
Sealing:	Room ambient

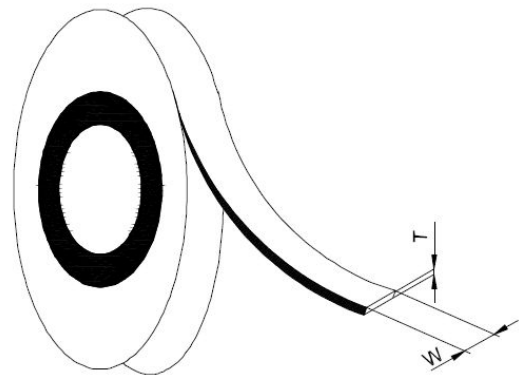

A.4.3 Leader and Trailer

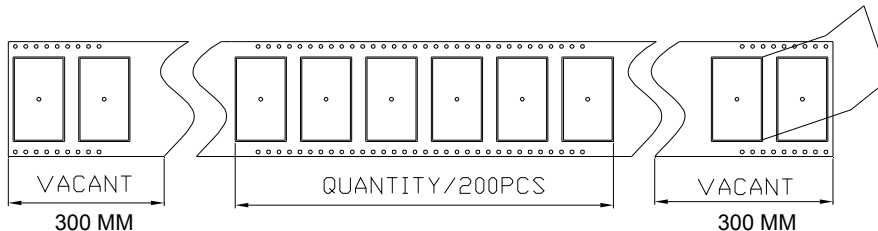

A.4.4 Reel Dimensions:

All dimensions are in mm.

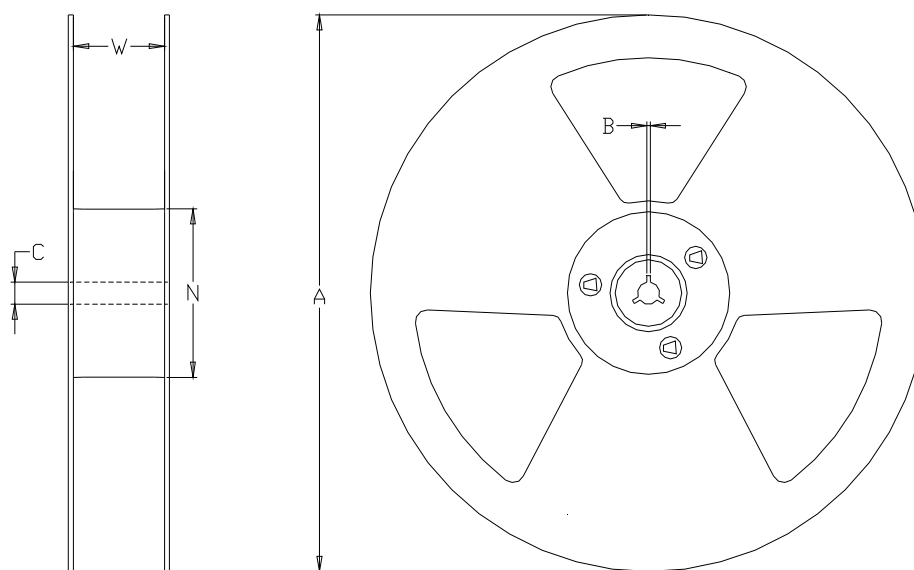

Module type:	A	B	C	N	W (min)
JN5148-xxx-M00/03	330 ±1.0	2.2±0.5	13 ±0.2	100 +0.1	44.5 ±0.3
JN5148-xxx-M04	330 ±1.0	2.2±0.5	13 ±0.2	100 +0.1	56.5 ±0.3

A.5 Related Documents

- [1] IEEE Std 802.15.4-2003 IEEE Standard for Information Technology – Part 15.4 Wireless Medium Access Control (MAC) and Physical Layer (PHY) Specifications for Low-Rate Wireless Personal Area Networks (LR-WPANs)
- [2] JN-DS- JN5148 Wireless Microcontroller Datasheet
- [3] JN-RM-2002 802.15.4 Stack API

A.6 Federal Communication Commission Interference Statement

This equipment will have been tested and found to comply with the limits for a Class B digital device, pursuant to Part 15 of the FCC Rules. These limits are designed to provide reasonable protection against harmful interference in a residential installation. This equipment generates, uses, and can radiate radio frequency energy and, if not installed and used in accordance with the instructions, may cause harmful interference to radio communications. However, there is no guarantee that interference will not occur in a particular installation. If this equipment does cause harmful interference to radio or television reception, which can be determined by turning the equipment off and on, the user is encouraged to try to correct the interference by one of the following measures:

- Reorient or relocate the receiving antenna.
- Increase the separation between the equipment and receiver.
- Connect the equipment into an outlet on a circuit different from that to which the receiver is connected.
- Consult the dealer or an experienced radio/TV technician for help.

This device will comply with Part 15 of the FCC Rules. Operation is subject to the following two conditions: (1) This device may not cause harmful interference, and (2) this device must accept any interference received, including interference that may cause undesired operation.

FCC Caution: Any changes or modifications not expressly approved by the party responsible for compliance could void the user's authority to operate this equipment.

WARNING!

FCC Radiation Exposure Statement:

This portable equipment with its antenna complies with FCC's RF radiation exposure limits set forth for an uncontrolled environment. To maintain compliance follow the instructions below;

1. This transmitter must not be co-located or operating in conjunction with any other antenna or transmitter.
2. Avoid direct contact to the antenna, or keep it to a minimum while using this equipment.

This transmitter module is authorized to be used in other devices only by OEM integrators under the following condition:

The transmitter module must not be co-located with any other antenna or transmitter.

As long as the above condition is met, further transmitter testing will not be required. However, the OEM integrator is still responsible for testing their end product for any additional compliance requirements required with this module installed (for example, digital device emissions, PC peripheral requirements, etc.).

A.6.1 Antennas to be approved by FCC for use with JN5148 modules

	Brand	Model Number	Description	Gain (dBi)	Connector type
1	Aveslink Technology, Inc	E-0360-AT	Patch Antenna - outdoor	18	RP-N
2	Aveslink Technology, Inc	E-0260-AT	Patch Antenna - outdoor	15	RP-N
3	Aveslink Technology, Inc	E-1050-AT	Vertical - outdoor colinear	15	RP-N
4	Aveslink Technology, Inc	E-1040-AT	Vertical - outdoor colinear	12	RP-N
5	Aveslink Technology, Inc	E-0100-AC	Patch Antenna - flying lead	10	RP-SMA
6	Aveslink Technology, Inc	E-1030-AT	Vertical - outdoor colinear	9	RP-N
7	Aveslink Technology, Inc	E-1020-AT	Vertical - outdoor colinear	7	RP-N
8	Aveslink Technology, Inc	E-1710-GC	Vertical - swivel	7	RP-SMA
9	Aveslink Technology, Inc	E-1710-GM	Vertical - swivel	7	RP-TNC
10	Aveslink Technology, Inc	E-1511-GC	Vertical - swivel	5	RP-SMA
11	Aveslink Technology, Inc	E-0030-AA	Patch Antenna - flying lead	4	uFL
12	Aveslink Technology, Inc	E-0030-AC	Patch Antenna - flying lead	4	RP-SMA
13	Aveslink Technology, Inc	E-1204-AC	Ceiling antenna - flying lead	4	RP-SMA
14	Aveslink Technology, Inc	E-1520-CA	Vertical - bulkhead- flying lead	4	uFL
15	Aveslink Technology, Inc	E-1520-GC	Vertical - swivel	4	RP-SMA
16	Aveslink Technology, Inc	E-1450-GC	Vertical-swivel mount	4	RP-SMA
17	Nearson	S152CL-L-PX-2450S	Vertical - knuckle-flying lead	4	uFL
18	Antenna Factor	ANT-2.4-CW-RCL	Vertical - knuckle antenna	2.9	RP-SMA
19	Aveslink Technology, Inc	E-0901-AA	Embedded - flying lead	2.5	uFL
20	Antenna Factor	ANT-2.4-CW-RCT-RP	Vertical - knuckle antenna	2.2	RP-SMA
21	Antennova	2010B6090-01	Vertical - knuckle antenna	2.2	RP-SMA
22	Hyperlink Technology	HG2402RD-RSF	Vertical - knuckle antenna	2.2	RP-SMA
23	Aveslink Technology, Inc	E-0005-AC	Vertical- flying lead	2	RP-SMA
24	Aveslink Technology, Inc	E-2411-GC	Vertical - swivel	2	RP-SMA
25	Aveslink Technology, Inc	E-2410-CA	Vertical - bulkhead- flying lead	2	uFL
26	Aveslink Technology, Inc	E-2410-GC	Vertical - swivel	2	RP-SMA
27	Aveslink Technology, Inc	E-2820-CA	Vertical - bulkhead- flying lead	2	uFL
28	Aveslink Technology, Inc	E-2820-GC	Vertical - swivel	2	RP-SMA
29	Aveslink Technology, Inc	E-0903-AX	Embedded - nickel silver strip	2	None
30	Aveslink Technology, Inc	E-0904-AX	Embedded - nickel silver strip	2	None
31	Embedded Antenna Design	FBKR35068-RS-KR	Vertical - knuckle antenna	2	RP-SMA
32	Nearson	S131CL-L-PX-2450S	Vertical - knuckle-flying lead	2	uFL
33	Laird Technologies	WRR2400-IP04	Vertical - knuckle-flying lead	1.5	uFL
34	Laird Technologies	WRR2400-RPSMA	Vertical - knuckle-flying lead	1.3	RP-SMA
35	Aveslink Technology, Inc	E-6170-DA	Vertical - right angle	1	uFL
36	Laird Technologies	WCR2400-SMRP	Vertical - knuckle antenna	1	RP-SMA

These antennae or versions with alternative connectors may be used to meet European regulations.

This device has been designed to operate with the antennas listed above, and having a maximum gain of 4.4 dBi. Antennas not included in this list or having a gain greater than 4.4 dBi are strictly prohibited for use with this device. The required antenna impedance is 50 ohms.

A.6.2 High Power Module usage limitation

The high power module variants are classified as 'mobile' device pursuant with FCC § 2.1091 and **must not** be used at a distance of < 20 cm (8") from any nearby people.

IMPORTANT NOTE: In the event that these conditions can not be met (for certain configurations or co-location with another transmitter), then the FCC authorization is no longer considered valid and the FCC ID can not be used on the final product. In these circumstances, the OEM integrator will be responsible for re-evaluating the end product (including the transmitter) and obtaining a separate FCC authorization.

The OEM integrator has to be aware not to provide information to the end user regarding how to install or remove this RF module in the user manual of the end product.

The user manual for the end product must include the following information in a prominent location;

"To comply with FCC's RF radiation exposure requirements, the antenna(s) used for this transmitter must not be co-located or operating in conjunction with any other antenna or transmitter."

A.6.3 High Power Module channel restriction

The FCC grant for the TYOJN5148M4 does not permit the use of channel 26. Access to channel 26 is forbidden by the 802.15.4 MAC layer when the JN5148 chip is in high power mode. High power mode enables the use of DIO2 and DIO3 to control the external RX/TX switching necessary when using a high power module. Users will not be able to access channel 26 when using the JN5148-001-M04 module under any circumstances.

A.6.4 FCC End Product Labelling

The final 'end product' should be labelled in a visible area with the following:

"Contains TX FCC ID: TYOJN5148M0, TYOJN5148M3 or TYOJN5148M4 " to reflect the version of the module being used inside the product.

A.7 Industry Canada Statement

To reduce potential radio interference to other users, the antenna type and its gain should be so chosen that the equivalent isotropically radiated power (e.i.r.p.) is not more than that permitted for successful communication.

These modules have been designed to operate with antennas having a maximum gain of **18 dBi**. Antennas having a gain greater than **18 dBi** are strictly prohibited for use with this device. The required antenna impedance is 50 ohms.

As long as the above condition is met, further transmitter testing will not be required. However, the OEM integrator is still responsible for testing their end-product for any additional compliance requirements required with this module installed (for example, digital device emissions, PC peripheral requirements, etc).

A.7.1 Industry Canada End Product Labelling

For Industry Canada purposes the following should be used.

"Contains Industry Canada ID IC: 7438A-CYO5148M0, **IC: 7438A-CYO5148M3** or IC: **7438A-CYO5148M4**" to reflect the version of the module being used inside the product.

A.8 European R & TTE Directive 1999/5/EC Statement

All modules listed in this datasheet will be compliant with ETSI EN 300 328V1.7.1 (2006/05) and will be subject to a Notified Body Opinion.

The modules will be approved for use with the antennas listed in the following table. The high power module M04 is limited to an antenna with a gain of 2.2 dBi or less.

Brand	Model Number	Description	Gain	Connector type
Antenna Factor	ANT-2.4-CW-RCL	Vertical - knuckle antenna	2.9dBi	RP-SMA
Antenna Factor	ANT-2.4-CW-RCT-SS	Vertical - knuckle antenna	2.2dBi	SMA
Laird Technologies	WCR2400-SMA	Vertical - knuckle antenna	1.0dBi	SMA
Laird Technologies	WRR2400-IP04	Vertical - knuckle-flying lead	1.5dBi	uFL
Embedded Antenna Design	BKR2400	Vertical - knuckle antenna	2.0dBi	SMA
Antennova	Titanis	Vertical - knuckle antenna	4.4dBi	SMA
Nearson	S131CL-L-PX-2450S	Vertical - knuckle-flying lead	2.0dBi	uFL
Nearson	S152CL-L-PX-2450S	Vertical - knuckle-flying lead	4.0dBi	uFL
Aveslink Technology, Inc	E-0030-AA	Patch Antenna - flying lead	4dBi	uFL
Aveslink Technology, Inc	E-0030-AB	Patch Antenna - flying lead	4dBi	SMA
Aveslink Technology, Inc	E-1204-AB	Ceiling antenna - flying lead	4dBi	SMA
Aveslink Technology, Inc	E-0005-AB	Vertical- flying lead	2dBi	SMA
Aveslink Technology, Inc	E-1450-GB	Vertical-swivel mount	4dBi	SMA
Aveslink Technology, Inc	E-1450-GC	Vertical-swivel mount	4dBi	RP-SMA
Aveslink Technology, Inc	E-1520-CA	Vertical - bulkhead- flying lead	4dBi	uFL
Aveslink Technology, Inc	E-1520-GB	Vertical - swivel	4dBi	SMA
Aveslink Technology, Inc	E-1520-GC	Vertical - swivel	4dBi	RP-SMA
Aveslink Technology, Inc	E-2411-GB	Vertical - swivel	2dBi	SMA
Aveslink Technology, Inc	E-2410-CA	Vertical - bulkhead- flying lead	2dBi	uFL
Aveslink Technology, Inc	E-2410-GB	Vertical - swivel	2dBi	SMA
Aveslink Technology, Inc	E-2410-GC	Vertical - swivel	2dBi	RP-SMA
Aveslink Technology, Inc	E-2410-HA	Vertical - swivel -flying lead	2dBi	uFL
Aveslink Technology, Inc	E-2820-CA	Vertical - bulkhead- flying lead	2dBi	uFL
Aveslink Technology, Inc	E-2820-GB	Vertical - swivel	2dBi	SMA
Aveslink Technology, Inc	E-2820-GC	Vertical - swivel	2dBi	RP-SMA
Aveslink Technology, Inc	E-6170-DA	Vertical - right angle	1dBi	uFL
Aveslink Technology, Inc	E-0901-AA	Embedded - flying lead	2.5dBi	uFL
Hyperlink Technologies	HG2402RD-RSF	Vertical – tilt and swivel	2.2dBi	RP-SMA

A.9 RoHS Compliance

JN5148-001-My devices meet the requirements of Directive 2002/95/EC of the European Parliament and of the Council on the Restriction of Hazardous Substance (RoHS).

The JN5148-001-M00, M03 and M04 modules meet the requirements of Chinese RoHS requirements SJ/T11363-2006.

Full data can be found on the Jennic support website at www.jennic.com/support

A.10 Status Information

The status of this Data Sheet is **Preliminary**.

Jennic products progress according to the following format:

Advanced

The Data Sheet shows the specification of a product in planning or in development. The functionality and electrical performance specifications are target values and may be used as a guide to the final specification. Jennic reserves the right to make changes to the product specification at anytime without notice.

Preliminary

The Data Sheet shows the specification of a product that is commercially available, but is not yet fully qualified. The functionality of the product is final. The electrical performance specifications are target values and may used as a guide to the final specification. Modules are identified with an Rx suffix, for example JN5148-001-M00R2. Jennic reserves the right to make changes to the product specification at anytime without notice.

Production

This is the final Data Sheet for the product. All functional and electrical performance specifications, including minimum and maximum values are final. This Data Sheet supersedes all previous document versions. Jennic reserves the right to make changes to the product specification at anytime to improve its performance.

A.11 Disclaimers

The contents of this document are subject to change without notice. Jennic reserves the right to make changes, without notice, in the products, including circuits and/or software, described or contained therein. Information contained in this document regarding device applications and the like is intended through suggestion only and may be superseded by updates. It is your responsibility to ensure that your application meets with your specifications.

Jennic warrants performance of its hardware products to the specifications applicable at the time of sale in accordance with Jennic's standard warranty. Testing and other quality control techniques are used to the extent Jennic deems necessary to support this warranty. Except where mandatory by government requirements, testing of all parameters of each product is not necessarily performed.

Jennic assumes no responsibility or liability for the use of any of these products, conveys no license or title under any patent, copyright, or mask work right to these products, and makes no representations or warranties that these products are free from patent, copyright, or mask work infringement, unless otherwise specified.

Jennic products are not intended for use in life support systems, appliances or systems where malfunction of these products can reasonably be expected to result in personal injury, death or severe property or environmental damage. Jennic customers using or selling these products for use in such applications do so at their own risk and agree to fully indemnify Jennic for any damages resulting from such use.

All products are sold subject to Jennic's terms and conditions of sale supplied at the time of order acknowledgment.

All trademarks are the property of their respective owners.

A.12 Version Control

Version	Notes
1.0	1st Issue of Advanced Datasheet
1.1	1st Issue of Preliminary Datasheet, minor parametric changes and addition of Appendix A6.3

Jennic Ltd
Furnival Street
Sheffield
S1 4QT
United Kingdom

Tel: +44 (0)114 281 2655
Fax: +44 (0) 114 281 2951
E-mail: info@jennic.com

For the contact details of your local Jennic office or distributor, refer to the Jennic web site:

www.jennic.com