

UM10955

JN5179-USB-Dongle User Manual

Rev. 1.1 — 24 February 2016

User manual

Document information

Info	Content
Keywords	JN5179, ZigBee, dongle, USB
Abstract	JN5179 USB dongle user manual



Revision history

Rev	Date	Description
1.0	20151209	First release
1.1	20160224	Section 4.1.1 : updated. Section 4.2: updated. Section 4.3: added.

Contact information

For more information, please visit: <http://www.nxp.com>

1. Introduction

This chapter introduces the NXP JN5179 USB Dongle (OM15021), which provides a hardware development platform for wireless microcontroller applications with a USB interface.

1.1 Overview

The JN5179 USB Dongle features a JN5179 wireless microcontroller and allows communication with this JN5179 device from a USB connection. The JN5179 device can act as a node of a wireless network. Thus, the dongle provides an easy way of interfacing a host machine (such as a PC) to a wireless network based on the IEEE802.15.4, ZigBee Smart Energy or ZigBee-Home Automation networking protocol. An FTDI device provides the USB connection between the host machine and the JN5179 device, which in turn provides the radio interface to the wireless network.

Typical uses of the dongle include:

- A complete and stable hardware environment for the development of IEEE802.15.4, ZigBee Smart Energy and ZigBee-Home Automation networking applications, facilitating an accelerated time-to-market for wireless network products
- The basis of a packet sniffer for IEEE 802.15.4-based wireless communications
- A means of integrating the host machine into a wireless network, typically as the network Coordinator

The small-footprint PCB of the dongle provides all the necessary components for a wireless microcontroller with access to a USB connection. All RF layout and decoupling issues are handled by the design of this dongle. Therefore, this design is ready for application development without the necessity of hardware development.

The JN5179 USB dongle, shown [Fig 1](#), is supplied in the JN5179-EK005 Evaluation Kit.

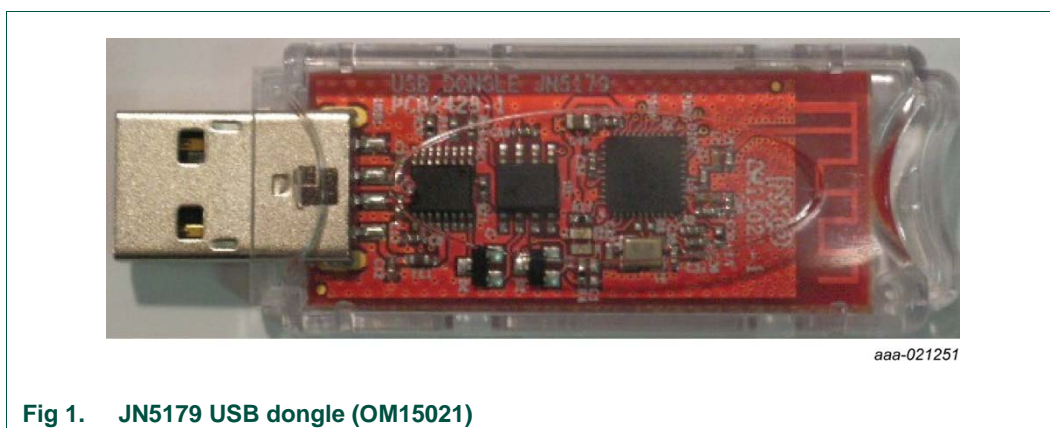

1.2 Features

The dongle has the following features:

- USB 2.0 Full-Speed Compatible Interface
- IEEE 802.15.4-based wireless microcontroller (JN5179) with the following radio characteristics:
 - Transmit power: 8.5 dBm (typ.), can be increased to 10 dBm (typ.)
 - Transmit current: 19.6 mA (typ) at 8.5 dBm / 23.3 mA (typ.) at 10 dBm
 - Receive sensitivity: -96dBm (typ.)
 - Receive current: 13 mA (typ.)
- Integrated printed RF antenna
- General-purpose LEDs (one green, one orange)
- Serial Flash memory device (4 Mbits)
- 32-kHz crystal oscillator

2. Hardware overview

2.1 Dongle layout

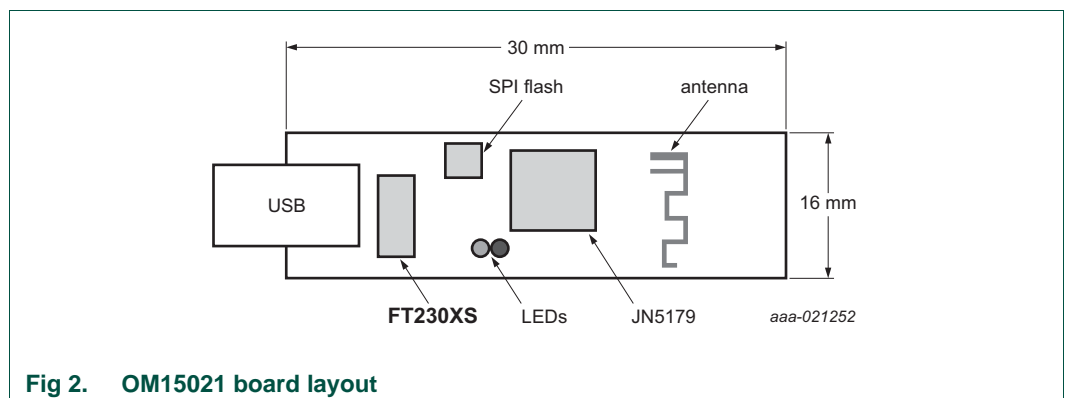

2.2 Dongle block diagram

The [Fig 3](#) illustrates the main hardware blocks of the dongle.

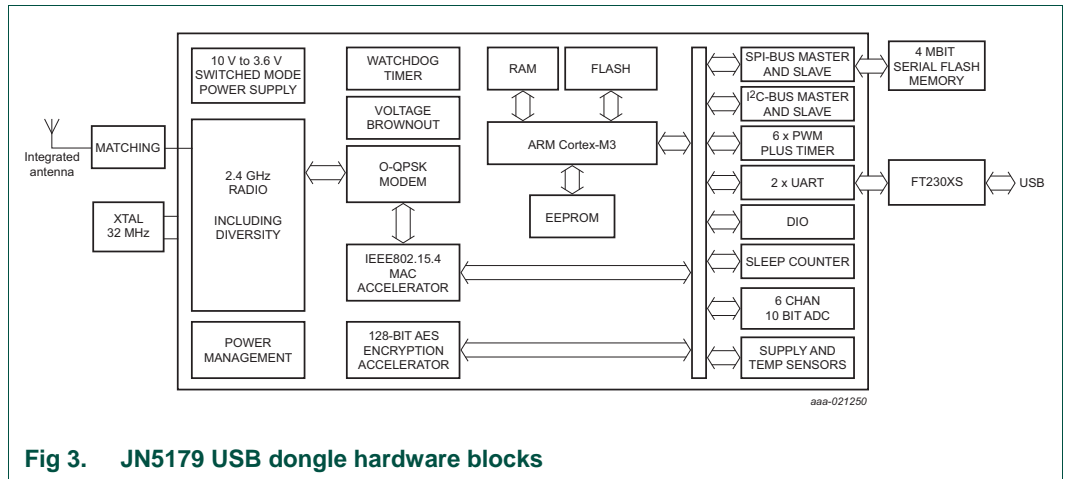

Fig 3. JN5179 USB dongle hardware blocks

2.3 Hardware components

The hardware components on the board are described in the following sub-sections.

- JN5179 wireless microcontroller – see [section 2.3.1](#)
- FTDI FT230XS driver device – see [section 2.3.2](#)
- LEDs – see [section 2.3.3](#)

2.3.1 JN5179 device

The JN5179 circuit on the board is based around the standard JN5179-001-M00 module. However, it is built on a 2-layer board, as the DIOs do not need to be externally available.

The JN5179 device uses an integrated antenna on the PCB of the dongle.

2.3.2 FT230XS device

The FT230XS device is connected to the USB connector and acts as an interface between the PC and the JN5179 device. The FT230XS will enumerate on the PC as a virtual COM port connected directly to UART0 on the JN5179 device.

The IO controls C2 and C3 in the FT230XS device need to be set to 'GPIO Mode' to allow the RESET and PGM signals to operate correctly. To do this, execute the following instructions.

1. Download the application FT_Prog from the FTDI website www.ftdichip.com
2. Insert the JN5179 USB Dongle into a USB port of your computer and wait for the device to enumerate
3. Start FT_Prog and click Scan and Parse (the magnifying glass button)
4. Update the IO controls C2 and C3 to I/O MODE – see [Fig 4](#)

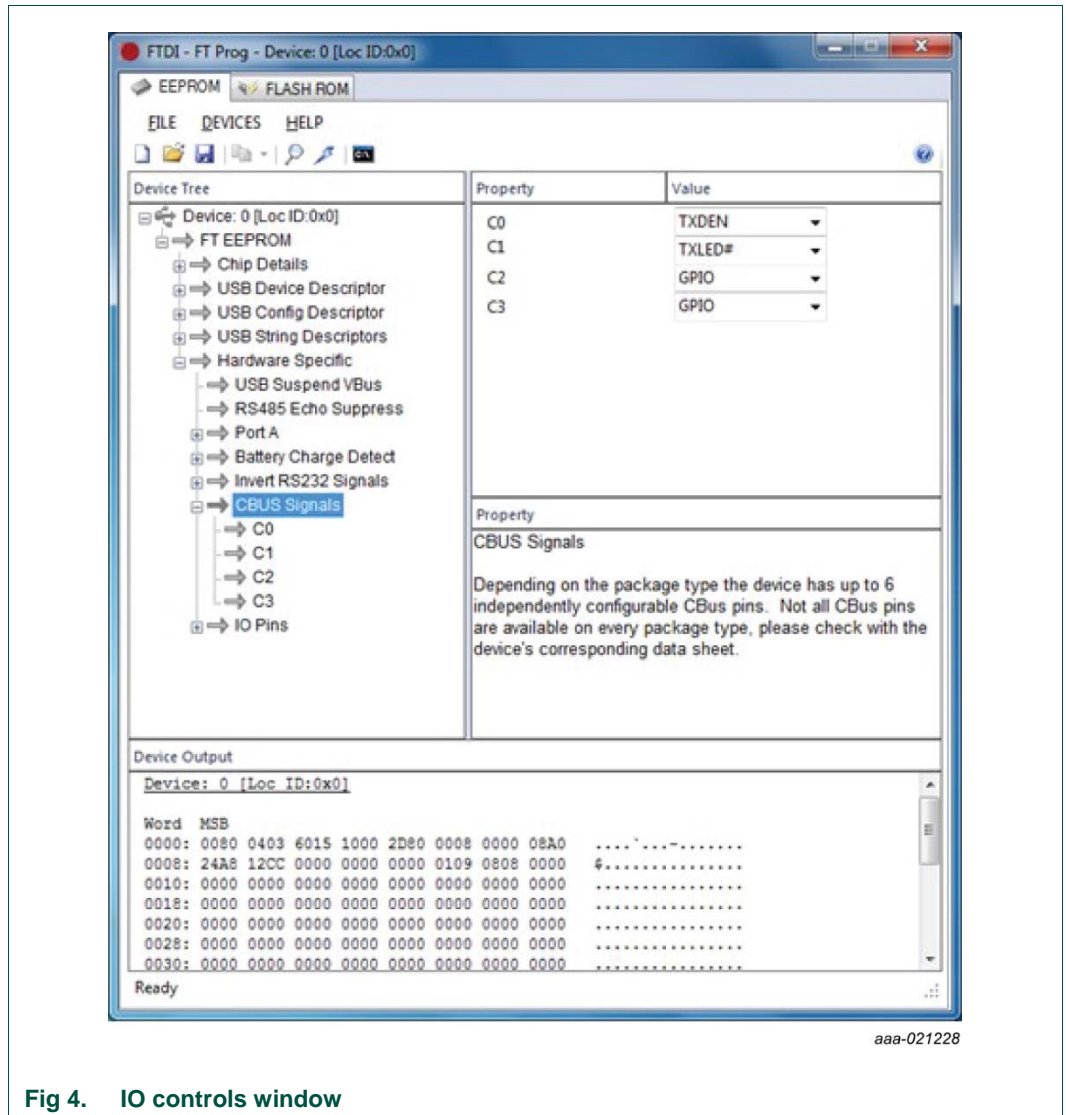

Fig 4. IO controls window

5. Click Program Devices (the lightning button)
6. On the resulting screen, click Program – see [Fig 5](#)

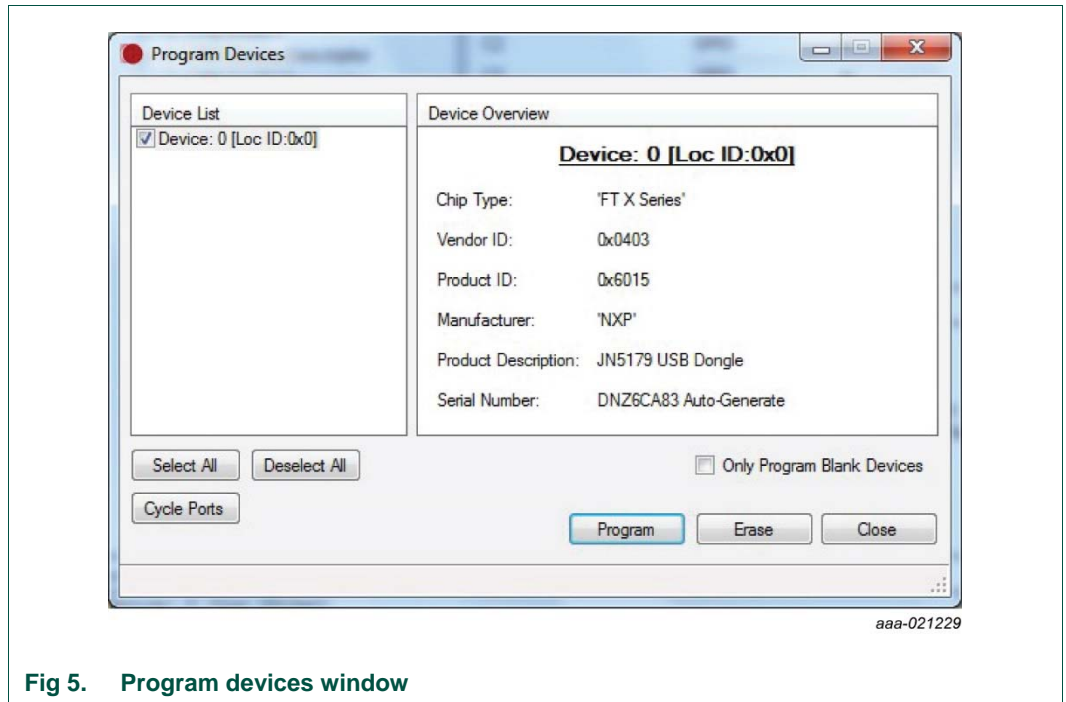

Fig 5. Program devices window

2.3.3 LEDs

There are two surface-mounted LEDs that can be controlled by the JN5179 wireless microcontroller (see Fig 2 for locations):

- LED D1 (orange)
- LED D2 (green)

Both LEDs are connected to DIO14 and DIO15. These DIOs can be used to control the LEDs as indicated in the Table 1.

Table 1. DIO control of LEDs

		DIO14	
		Low	High
DIO15	Low	D1: Off	D1: Off
		D2: Off	D2: On
	High	D1: On	D1: Off
		D2: Off	D2: Off

3. Flash programming

When the JN5179 USB dongle is powered up, it attempts to run an application from the internal Flash memory of the JN5179 device. This may be a self-contained application that sends and receives wireless data, and which does not need to communicate with the host. Alternatively, it may communicate via the USB with an application running on the

host, such as a Windows program, and also communicate with a wireless device or network.

In order to program an application binary into Flash memory, the JN51xx Production Flash Programmer can be used, which is described in the JN51xx Production Flash Programmer User Guide (JN-UG-3099). This programming utility will place the JN5179 into its programming mode. It will then download the program to the Flash memory and reset the JN5179 device, causing the application to be executed.

4. Compliance statements and documentation

The FCC ID number of the JN5179 USB dongle is XXMJN5179U0

The IC ID number of the JN5179 USB dongle is 8764A-JN5179U0

4.1 FCC statements and documentation

This section contains the Federal Communication Commission (FCC) statements and documents.

4.1.1 FCC interference statement

This equipment has been tested and found to comply with the limits for a Class B digital device, pursuant to Part 15 of the FCC Rules. These limits are designed to provide reasonable protection against harmful interference in a residential installation. This equipment generates, uses, and can radiate radio frequency energy and, if not installed and used in accordance with the instructions, may cause harmful interference to radio communications. However, there is no guarantee that interference will not occur in a particular installation. If this equipment does cause harmful interference to radio or television reception, which can be determined by turning the equipment off and on, the user is encouraged to try to correct the interference by one of the following measures:

- Reorient or relocate the receiving antenna
- Increase the separation between the equipment and receiver
- Connect the equipment into an outlet on a circuit different from that to which the receiver is connected
- Consult the dealer or an experienced radio/TV technician for help

This device complies with Part 15 of the FCC rules. Operation is subject to the following two conditions: (1) This device may not cause harmful interference, and (2) this device must accept any interference received, including interference that may cause undesired operation.

FCC caution: Any changes or modifications not expressly approved by the party responsible for compliance could void the user's authority to operate this equipment.

WARNING!

FCC radiation exposure statement:

This portable equipment with its integrated antenna complies with FCC's RF radiation exposure limits set forth for an uncontrolled environment. To maintain compliance follow the instructions below;

Avoid direct contact to the antenna, or keep it to a 20 cm minimum distance while using this equipment. This device must not be collocated or operating in conjunction with another antenna or transmitter.

4.2 Industry Canada statement

This device complies with Industry Canada license-exempt RSS standard(s). Operation is subject to the following two conditions: (1) this device may not cause interference, and (2) this device must accept any interference, including interference that may cause undesired operation of the device.

This device complies with Industry Canada RF radiation exposure limits set forth for general population (uncontrolled exposure). This device must be installed to provide a separation distance of at least 20 cm from all persons and must not be collocated or operating in conjunction with any other antenna or transmitter.

Le présent appareil est conforme aux CNR d'Industrie Canada applicables aux appareils radio exempts de licence. L'exploitation est autorisée aux deux conditions suivantes: (1) il ne doit pas produire de brouillage, et (2) l'utilisateur du dispositif doit être prêt à accepter tout brouillage radioélectrique reçu, même si ce brouillage est susceptible de compromettre le fonctionnement du dispositif.

Le présent appareil est conforme aux niveaux limites d'exigences d'exposition RF aux personnes définies par Industrie Canada. Cet appareil doit être installé afin d'offrir une distance de séparation d'au moins 20 cm avec l'utilisateur, et ne doit pas être installé à proximité ou être utilisé en conjonction avec une autre antenne ou un autre émetteur.

4.3 Module integration special warnings for US and Canada

- The JN5179-001-U0 module is considered as component that will be operated in combination with the final equipment. Then, the final equipment (including power supply system) still needs to re-confirm that the whole system complies with intentional and unintentional emission requirements.
- The statement warning of 20 cm separation distance and warning of collocation should appear in the user manuals of end products.
- The end product's regulatory label should mention:
"Contains FCC ID: XXMJN5179U0 and IC: 8764A-JN5179U0".

5. Abbreviations

Table 2. Abbreviations

Acronym	Description
BOM	Bill Of Materials
DIO	Digital Input/Output
FCC	Federal Communication Commission
IC	Industry Canada
PCB	Printed Circuit Board
UART	Universal Asynchronous Receiver/Transmitter
USB	Universal Serial Bus

6. References

- [1] **JN5179** – JN5179 Data Sheet
- [2] **OM15021_JN5179_USB_Dongle_2V0** – OM15021 USB dongle PCB files

7. Legal information

7.1 Definitions

Draft — The document is a draft version only. The content is still under internal review and subject to formal approval, which may result in modifications or additions. NXP Semiconductors does not give any representations or warranties as to the accuracy or completeness of information included herein and shall have no liability for the consequences of use of such information.

7.2 Disclaimers

Limited warranty and liability — Information in this document is believed to be accurate and reliable. However, NXP Semiconductors does not give any representations or warranties, expressed or implied, as to the accuracy or completeness of such information and shall have no liability for the consequences of use of such information. NXP Semiconductors takes no responsibility for the content in this document if provided by an information source outside of NXP Semiconductors.

In no event shall NXP Semiconductors be liable for any indirect, incidental, punitive, special or consequential damages (including - without limitation - lost profits, lost savings, business interruption, costs related to the removal or replacement of any products or rework charges) whether or not such damages are based on tort (including negligence), warranty, breach of contract or any other legal theory.

Notwithstanding any damages that customer might incur for any reason whatsoever, NXP Semiconductors' aggregate and cumulative liability towards customer for the products described herein shall be limited in accordance with the *Terms and conditions of commercial sale* of NXP Semiconductors.

Right to make changes — NXP Semiconductors reserves the right to make changes to information published in this document, including without limitation specifications and product descriptions, at any time and without notice. This document supersedes and replaces all information supplied prior to the publication hereof.

Suitability for use — NXP Semiconductors products are not designed, authorized or warranted to be suitable for use in life support, life-critical or safety-critical systems or equipment, nor in applications where failure or malfunction of an NXP Semiconductors product can reasonably be expected to result in personal injury, death or severe property or environmental damage. NXP Semiconductors and its suppliers accept no liability for inclusion and/or use of NXP Semiconductors products in such equipment or applications and therefore such inclusion and/or use is at the customer's own risk.

Applications — Applications that are described herein for any of these products are for illustrative purposes only. NXP Semiconductors makes no representation or warranty that such applications will be suitable for the specified use without further testing or modification.

Customers are responsible for the design and operation of their applications and products using NXP Semiconductors products, and NXP Semiconductors accepts no liability for any assistance with applications or

customer product design. It is customer's sole responsibility to determine whether the NXP Semiconductors product is suitable and fit for the customer's applications and products planned, as well as for the planned application and use of customer's third party customer(s). Customers should provide appropriate design and operating safeguards to minimize the risks associated with their applications and products.

NXP Semiconductors does not accept any liability related to any default, damage, costs or problem which is based on any weakness or default in the customer's applications or products, or the application or use by customer's third party customer(s). Customer is responsible for doing all necessary testing for the customer's applications and products using NXP Semiconductors products in order to avoid a default of the applications and the products or of the application or use by customer's third party customer(s). NXP does not accept any liability in this respect.

Export control — This document as well as the item(s) described herein may be subject to export control regulations. Export might require a prior authorization from competent authorities.

Translations — A non-English (translated) version of a document is for reference only. The English version shall prevail in case of any discrepancy between the translated and English versions.

Evaluation products — This product is provided on an "as is" and "with all faults" basis for evaluation purposes only. NXP Semiconductors, its affiliates and their suppliers expressly disclaim all warranties, whether express, implied or statutory, including but not limited to the implied warranties of non-infringement, merchantability and fitness for a particular purpose. The entire risk as to the quality, or arising out of the use or performance, of this product remains with customer.

In no event shall NXP Semiconductors, its affiliates or their suppliers be liable to customer for any special, indirect, consequential, punitive or incidental damages (including without limitation damages for loss of business, business interruption, loss of use, loss of data or information, and the like) arising out of the use of or inability to use the product, whether or not based on tort (including negligence), strict liability, breach of contract, breach of warranty or any other theory, even if advised of the possibility of such damages.

Notwithstanding any damages that customer might incur for any reason whatsoever (including without limitation, all damages referenced above and all direct or general damages), the entire liability of NXP Semiconductors, its affiliates and their suppliers and customer's exclusive remedy for all of the foregoing shall be limited to actual damages incurred by customer based on reasonable reliance up to the greater of the amount actually paid by customer for the product or five dollars (US\$5.00). The foregoing limitations, exclusions and disclaimers shall apply to the maximum extent permitted by applicable law, even if any remedy fails of its essential purpose.

7.3 Trademarks

Notice: All referenced brands, product names, service names and trademarks are property of their respective owners.

8. List of figures

Fig 1.	JN5179 USB dongle (OM15021)	3
Fig 2.	OM15021 board layout	4
Fig 3.	JN5179 USB dongle hardware blocks	5
Fig 4.	IO controls window.....	6
Fig 5.	Program devices window	7

9. List of tables

Table 1. DIO control of LEDs	7
Table 2. Abbreviations	10

10. Contents

1.	Introduction	3
1.1	Overview	3
1.2	Features	4
2.	Hardware overview	4
2.1	Dongle layout	4
2.2	Dongle block diagram	5
2.3	Hardware components	5
2.3.1	JN5179 device	5
2.3.2	FT230XS device.....	5
2.3.3	LEDs	7
3.	Flash programming	7
4.	Compliance statements and documentation	8
4.1	FCC statements and documentation	8
4.1.1	FCC interference statement	8
4.2	Industry Canada statement	9
4.3	Module integration special warnings for US and Canada.....	9
5.	Abbreviations	10
6.	References	10
7.	Legal information	11
7.1	Definitions	11
7.2	Disclaimers.....	11
7.3	Trademarks	11
8.	List of figures.....	12
9.	List of tables	13
10.	Contents.....	14

Please be aware that important notices concerning this document and the product(s) described herein, have been included in the section 'Legal information'.
