

Narco Avionics

AT155 TSO Transponder

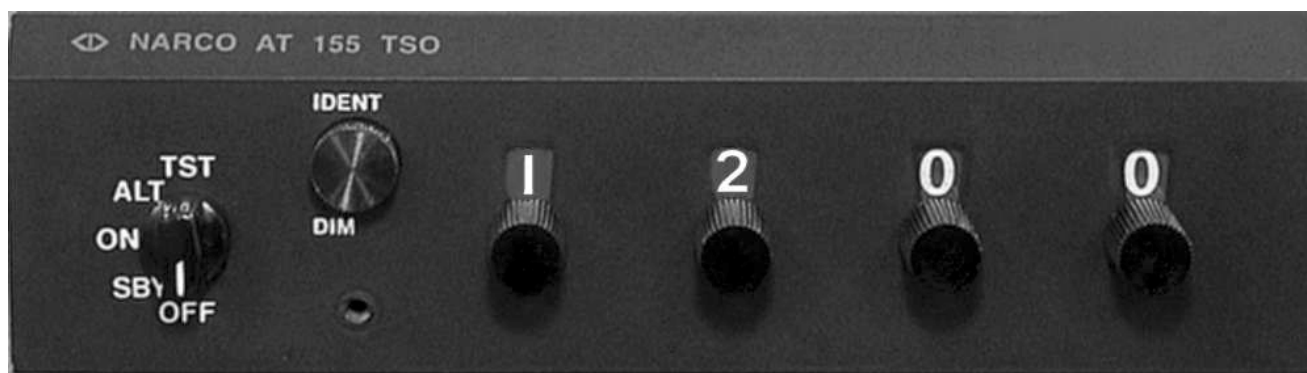

Installation Manual
03608-0620



Narco Avionics Inc.
270 Commerce Drive
Ft. Washington, Pa. 19034
U.S.A.

NOTICE

While every effort has been made by Narco Avionics Inc.
to ensure accuracy in the preparation of this Installation Manual,
Narco assumes no responsibility for errors or omissions

Narco Avionics can be reached by calling :

Phone : 215-643-2900

FAX : 215-643-0197

Or on the Internet at www.narcoavionics.com

**Narco Avionics AT155 TSO
TABLE OF CONTENTS**

SECTION NUMBER	TITLE	PAGE NUMBER
1.1	GENERAL	1-1
1.1.1	Manual Organization	1-1
1.2	PRODUCT DESCRIPTION	1-1
1.3	PRODUCT SPECIFICATIONS	1-2
1.4	TSO EXPLANATION	1-3
1.4.1	AT155 Antenna	1-3
1.5	UNITS AND ACCESSORIES SUPPLIED	1-3
1.6	OPTIONAL ACCESSORIES	1-4
1.7	MISCELLANEOUS ITEMS REQUIRED BUT <u>NOT</u> SUPPLIED.	1-4
1.8	OPERATOR LICENSE REQUIREMENTS	1-4
1.9	OPERATION	1-5
1.9.1	Function Selector Switch	1-5
1.9.2	IDENT/DIM	1-6
1.9.3	Code Selector	1-6
2.1	INTRODUCTION	2-1
2.2	PRELIMINARY INSPECTION	2-1
2.2.1	Unpacking	2-1
2.2.2	Electrical Bench Test.	2-2
2.2.2.1	Test Equipment Required.	2-2
2.2.2.2	Test Procedure	2-2
2.3	MECHANICAL INSTALLATION.	2-5
2.3.1	Mounting Tray	2-5
2.3.2	Insertion And Removal Of The AT155	2-5
2.4	ANTENNA INSTALLATION	2-7
2.4.1	Antenna Location And Mounting.	2-7
2.4.2	Antenna Extension Cable.	2-8
2.5	ELECTRICAL INSTALLATION	2-9
2.5.1	Power And Interconnect Cable	2-9
2.5.2	Cable Fabrication	2-11
2.5.3	Pilot Lamps	2-12
2.5.4	External Suppression	2-12
2.5.5	Remote IDENT	2-13
2.5.6	Altitude Digitizer	2-13
2.6	POST INSTALLATION TESTS	2-13
2.6.1	Preflight Tests	2-13
2.6.2	Flight Test	2-14
2.7	AIRCRAFT LICENSE REQUIREMENTS.	2-14
	APPENDIX A – CERTIFICATION DOCUMENTS	
A.1	ENVIRONMENTAL QUALIFICATION FORM	A-1
A.2	CONTINUED AIRWORTHINESS	A-2
R.1	MANUAL REVISION HISTORY	R-1

LIST OF ILLUSTRATIONS

FIGURE NUMBER	TITLE	PAGE NUMBER
1-1	AT155 TSO FRONT PANEL	1-7
2-1	BENCH TEST SET-UP	2-2
2-2	INSTALLATION DIAGRAM	2-6
2-3	AT155 ANTENNA MOUNTING	2-7
2-4	POWER AND INTERCONNECT CABLE	2-9
2-5	ORIENTATION DIAGRAM	2-10
2-6	CRIMPING TOOL	2-11
2-7	PILOT LAMP CONVERSION (SWITCH)	2-12

LIST OF TABLES

TABLE NUMBER	TITLE	PAGE NUMBER
1.1	UNITS AVAILABLE	1-3
1.2	INSTALLATION KIT (3604-0500)	1-4
2.1	ALTITUDE DIGITIZER INPUTS	2-4

1.1 GENERAL

In support of the Narco Avionics AT155 TSO Transponder, this manual provides detailed installation and operation procedures.

"This manual is intended for use only by persons qualified to service equipment in this manual pursuant to current regulatory requirements."

1.1.1 Manual Organization

Organized into two major sections the manual includes the following:

Section 1, Introduction - general information required in planning the installation

Section 2, Installation - detailed procedures for performing the mechanical and electrical installation

1.2 PRODUCT DESCRIPTION

The AT155 TSO consists of a receiver tuned to the frequency of a ground interrogation station (1030 MHz), logic circuitry to check the validity of the received interrogation and encode a reply containing pertinent identification information, and a transmitter which sends the coded reply to the ground station. When an optional altitude digitizer, Narco Model AR-850, is incorporated, coded altitude information will be transmitted to the ground station.

The AT155 has been designed for 14V or 28V operation. If the AT155 is replacing an existing AT50A or AT150 that uses an MP10 or a passive voltage converter these do not have to be removed.

1.3 PRODUCT SPECIFICATIONS

Mechanical

Physical Dimensions and Mounting Refer to appropriate diagram in Section 2

Weight 1.5lbs. (0.68kg)

Electrical

Power Requirements	13.75 VDC	27.5VDC
Standby	210mA	125mA
Transmit	1.2 A	530mA
Pilot Lamps	220mA	90mA

Receiver

Frequency 1030 MHz
 Frequency Stability Crystal Controlled
 Sensitivity Minimum trigger level (MTL) -69 to -74 dBm
 Side-Lobe Suppression (SLS) 99% or greater for signals from 3 dB to 50 dB above MTL
 Dynamic Range Logarithmic pulse response 50 dB or greater above MTL
 Bandwidth -60dB at ± 25 MHz

Decoding Capability

Mode A Pulse pair spaced at $8 \pm 0.5\mu s$
 Mode C Pulse pair spaced at $21 \pm 0.5\mu s$

Side-Lobe Suppression 35 μs suppression upon receipt of two pulses spaced $2 \pm 0.5\mu s$ apart.

Encoding Capability

Mode A 4096 reply codes selectable by front panel switches.
 Mode C Altitude reporting to 30,700 feet
 SPIP (Special Position Identification Pulse) An SPIP may be added to mode A for 20 ± 5 seconds

Transmitter

Frequency 1090 MHz
 Pulse Power 250 watts nominal, 190 watts minimum

External Interference Suppression (positive)

Pulse Amplitude 5 to 50 volts
 Load on Suppressor 3300 ohms

External Interference Suppression (negative)

Voltage 0.8V (maximum)
 Current 5 mA

1.4 TSO EXPLANATION

The TSO'd AT155 is designed to be instrument panel mounted within the cabin environment of fixed and rotary wing aircraft using piston or turbine single or multi-engines. It will operate and has been tested up to 30,000 feet for installations in non-pressurized as well as pressurized aircraft. This equipment requires direct current power but is designed to be installed in aircraft that have additional on board alternating current sources. Environmental testing was done to RTCA Document DO-160C. The Environmental categories are listed in Appendix A of this document.

1.4.1 AT155 Antenna

The AT155 Antenna meets the requirements of TSO-C74b Class 1, Environmental Category /JA/JAAAXXXXXX.

1.5 UNITS AND ACCESSORIES SUPPLIED

The following two tables may be used to: 1) check the contents of your order and, 2) to order additional Units or components.

TABLE 1.1 UNITS AVAILABLE

Unit Part Number	Unit and Description	Subassembly Part Number
03608-0300	AT155 TRANSPONDER ASSY, Complete with: AT155 Transponder, Tray Assy Antenna Assy Installation Kit	01545-0101 56282-0102 71233-0101 03604-0500

TABLE 1.2. INSTALLATION KIT (03604-0500)

Item	Part Number	Description	Qty
1	81213-0034	SPACER	2
2	41316-0009	CONNECTOR, 18 pin (Molex)	1
3	41317-0001	CONTACT, Crimp type	24
4	82802-0005	WASHER, Lock, Int. Tooth, #6	4
5	82900-0008	NUT, Hex, 6-32	4
6	82969-0004	WASHER, Lock, Split, #4	2
7	82814-0004	SCREW, Bind Hd, 4-40 x 5/16	2
8	82815-0405	SCREW, Bind Hd, 6-32 x 3/8	4
9	41152-0005	CONNECTOR, BNC	2
10	99090-0001	PAD, Spacer	4

1.6 OPTIONAL ACCESSORIES

- A Altitude Reporter - AR-850, order number 03753-0306.

1.7 MISCELLANEOUS ITEMS REQUIRED BUT NOT SUPPLIED

Refer to Installation Section for additional details.

- A. Sufficient length of #22 and #16 AWG hookup wire.
- B. Molex Hand Crimper, HT-1921, Narco Part Number 41314-0001.
- C. Molex Pin Ejector, HT-1884, Narco Part Number 41314-0002.

1.8 OPERATOR LICENSE REQUIREMENTS

The Federal Communications Commission requires that the transmitter in this equipment hold a Restricted Radio Telephone Operator Permit, or a license of a higher class. A permit may be obtained by any U.S. Citizen from the nearest field office of the FCC; no examination is required.

1.9 OPERATION



FIGURE 1-1 AT 155 FRONT PANEL

1.9.1 Function Selector Switch

The function selector is a five position rotary switch. The five positions are:

OFF- Turns OFF all power to the transponder.

SBY- Turns the transponder power supply ON. When in SBY, the transponder will not reply to any interrogation.

SBY is used at the request of the air traffic controller to selectivity clear his scope of traffic.

ON- Places the transponder in Mode A, the aircraft identification mode. In addition to the aircraft's identification code, the transponder will also reply to altitude interrogations (Mode C) with discreet signals that do not contain altitude information.

ALT- The ALT position activates all the necessary circuitry (transponder to optional altitude digitizer and return) to respond to ATC (Air Traffic Control) altitude interrogations and aircraft identification interrogations with standard pressure altitude (29.92 inches Hg).

The ALT position may be used in aircraft that are not equipped with the optional altitude digitizer, however, the only response will be discreet signals that do not contain altitude information.

TST- Turning the switch to the TST position injects a test signal into the transponder.

This test signal tests all transponder circuitry involved in a Mode A reply and causes the IDENT/DIM button to come on at full brilliance. This full brilliance indicates that the transponder has the capability of receiving and responding to interrogations. The TST function may be activated at any time, as it does not interfere with normal operation.

The TST position is spring loaded and must be held in position during the test process. Upon release, it will automatically return to the ALT position.

1.9.2 Ident/Dim

When the aircraft comes within range of a ground station, the IDENT/DIM button will blink ON and OFF. Momentarily depressing the IDENT/DIM button will activate the SPIP (Special Position Identification Pulse) signal for approximately 20 seconds. This signal will "paint" an instantly identifiable image on the controllers scope. This signal must only be used upon request of a "Squawk IDENT" from the controller. Use at any other time could interfere with another aircraft sending a SPIP. During "IDENT" periods, the IDENT/DIM button will glow constantly.

Rotating the IDENT/DIM button will control the intensity at which the button glows.

1.9.3 Code Selector

The CODE SELECTOR consists of four eight position switches that provide 4096 active identification codes. The identification code is selected by the controller.

2.1 INTRODUCTION

This section provides the necessary information for the installation of the AT155 TSO and, where required, optional accessories.

2.2 PRELIMINARY INSPECTION

2.2.1 Unpacking

Carefully unpack the Unit and inspect it for any damage that may have occurred during shipment. Refer to Section 1.5, Units and Accessories Supplied, and inventory the contents of the Installation Kit. Refer to Section 1.7, Miscellaneous Items Required but NOT Supplied for a listing of items and equipment needed for proper installation.

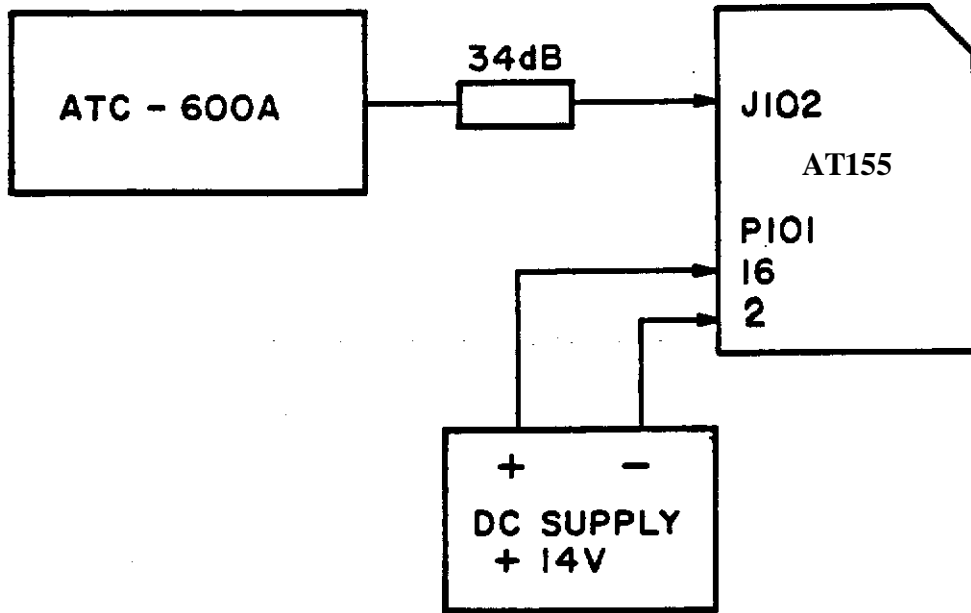

FIGURE 2-1. BENCH TEST SET-UP

2.2.2 Electrical Bench Test

2.2.2.1 Test Equipment Required

- A. Transponder and DME Test Set: IFR Model ATC-600A or equivalent.
- B. 34 dB attenuation pad.

2.2.2.2 Test Procedure

A. Set-Up

- 1. The AT155 should be tested while contained in the mounting tray with the RF cable installed.
- 2. When the AT155 is being interrogated by the ATC-600A, the IDENT/DIM button will blink ON and OFF.

B. Receiver Sensitivity

- 1. Place the AT155 in the ON mode. Place the ATC-600A in the A/C CODE mode.
- 2. Rotate the ATC-600A XPDR SIG. level control full counterclockwise. The % scale of the XPDRRPLY meter should read 100%.
- 3. Rotate the XPDR SIG level control clockwise until the XPDR RPLY meter reads 90%.
- 4. The XPDR SIG level control indicator should be between -69 and -74 dBm. This is the MTL of the transponder.

2.2.2.2

Continued

5. Repeat steps 2, 3, and 4 with the AT155 in the ALT mode and the ATC-600A in the A/C ALT mode. The difference between the MTL readings should not be greater than 1 dBm.

C. SLS Side-Lobe Suppression

1. Place the AT155 in the ON mode. Place the ATC-600A in the A/C CODE mode.
2. Rotate the XPDR SIG. level control full counterclockwise. The XPDR RPLY meter should read 100%.
3. Set the XPDR SIG. level control to 3 dB above MTL level established in step B-4.
4. Set the SLS switch to 0 dB. The XPDR RPLY meter should read zero.
5. Set the SLS switch to 9 dB. The XPDR RPLY meter should read 90% minimum.

D. Code Selection

1. Place the AT155 in the ON mode. Place the ATC-600A to the A/C CODE mode.
2. The ATC-600A numerical display should display the code selected by the AT155 Code Selector switches. Several different codes should be selected.
3. Consider the AT155 Code Selector switches to be labeled A, B, C, and D. Switch A should light the ATC-600A Binary Readout lamp A_1 when it is in the 1 position, the A_2 lamp in the 2 position, and the A_1 and A_2 lamps in the 3 position. In each switch position, the sum of the subscripts of the Binary Readout lamps that light should equal the number selected.
4. Repeat the above procedure for switches B, C, and D.

E. Transmitter Frequency

1. Place the AT155 in the ON mode and set the Code Selector switches to 0000.
2. Place the ATC-600A in the A/C CODE mode and set the POWER/FREQ switch to FREQ.
3. Adjust the GAIN control for a mid-scale reading on the POWER meter.
4. Rotate the XMTR FREQ control for a peak Indication on the POWER meter.
5. At peak, read the deviation from 1090 MHz directly from the XMTR FREQ control dial. The deviation should be no greater than ± 3 MHz.

F. Transmitter Power

1. Place the AT155 in the ON mode and set the Code Selector switches to 6050.
2. Place the ATC-600A in the A/C CODE mode and set the POWER/FREQ switch to POWER.
3. Read 190 watts (minimum) on the POWER meter.

G. Ident

1. Place the AT155 in the ON mode. Place the ATC-600A in the A/C CODE mode.
2. Momentarily depress the IDENT/DIM button on the AT155.
3. The AT155 IDENT/DIM button and the ATC-600A IDENT lamp should glow for approximately 20 ± 5 seconds.

2.2.2.2 Continued

H. Altitude Digitizer Inputs

The following procedure is a functional check of the Altitude Digitizer Inputs P101-6 through P101-14 only. Therefore, the numerical readout and INVALID ALT lamp on the ATC-600A should be ignored.

1. Place the AT155 in the ALT mode. Place the ATC-600A in the A/C ALT mode.
2. Placing an Altitude Digitizer Input at ground potential will activate a corresponding Binary Readout lamp on the ATC-600A. Table 2.1 lists the P101 pin numbers and their corresponding ATC-600A Binary Readout lamps.

TABLE 2.1 ALTITUDE DIGITIZER INPUTS

GROUND P101	ACTIVATE ATC-600A BINARY READOUT LAMP
6	A ₂
7	A ₁
8	A ₄
9	B ₄
10	B ₂
11	C ₂
12	B ₁
13	C ₄
14	C ₁

Disconnect the transponder from the Test Set-Up.

2.3 MECHANICAL INSTALLATION

2.3.1 Mounting Tray

The AT155 is supplied with a mounting tray which is designed to mount behind the aircraft instrument panel using four number 6 screws. Figure 2-2 provides a detailed drawing of the tray and the parts of the Installation Kit. This figure also provides all the necessary dimensions for the panel cutout as well as dimensions for mounting brackets locations. A full scale cutout template is also provided.

Mounting brackets (4) are not supplied due to the wide range in mounting requirements. Suitable mounting brackets may be fabricated from ordinary sheet metal or angle stock.

To ensure a sturdy mount, rear support for the unit should be provided.

2.3.2 Insertion And Removal Of The AT155

Before inserting the AT155 into the tray, refer to paragraph 2.5.4 and check that the PILOT LAMPS have been wired properly.

The AT155 is secured to the mounting tray by a hex head ramping screw running from the front panel to the rear of the unit and a self-locking nut attached to the tray rear panel. The access hole for the ramping screw is located on the front panel below the IDENT/DIM button (see Figure 1-1).

Slide the Unit straight into the tray until the ramping screw contacts the self-locking nut. Using a 5/64" hex wrench, turn the screw clockwise until the mating connector is engaged and the unit is firmly secured in the tray.

DO NOT RAM THE UNIT INTO THE TRAY OR OVER TIGHTEN THE RAMPING SCREW.

To remove the unit, turn the ramping screw counterclockwise until it is clear of the self-locking nut and then pull the unit straight out.

Refer to table 1.2 for installation kit.

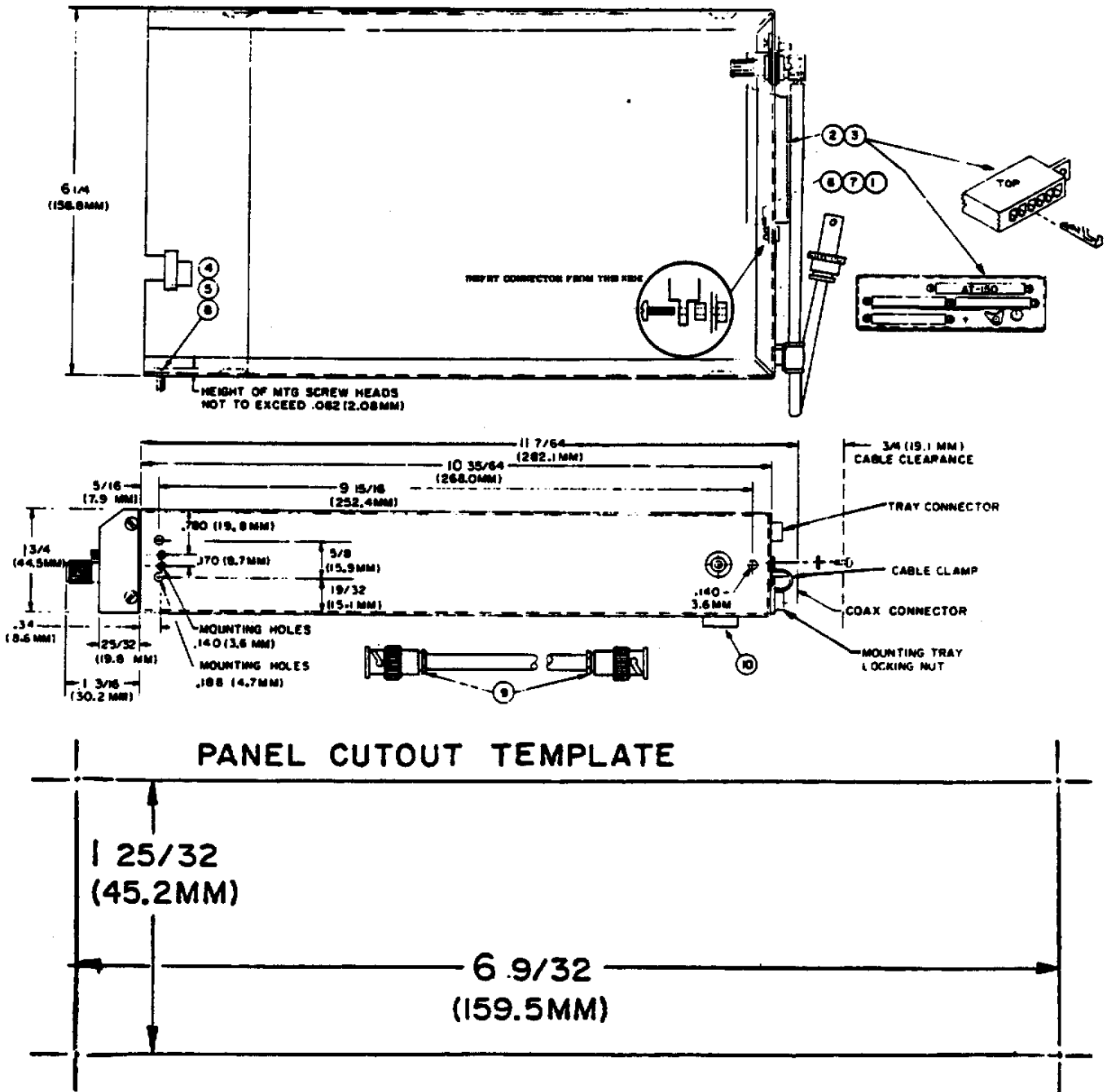

FIGURE 2-2. INSTALLATION DIAGRAM

2.4 ANTENNA INSTALLATION

2.4.1 Antenna Location And Mounting

The AT155 Antenna supplied in the Installation Kit should be mounted on the bottom surface of the aircraft and located such that it will be in a vertical position when the aircraft is in level flight. The area surrounding the antenna location should be free of protrusions which could interfere with the line-of-sight characteristics of a VHF signal. The following rules should be observed with regard to the ground plane.

A. Metallic Mounting Surface

Mount the antenna in the center of a 6" (152.4 mm), minimum radius, ground plane. Antenna located near the edge of a ground plane may cause holes in the radiation and reception patterns.

B. Non-Metallic Mounting Surface

Aircraft with fabric, wood, or fiberglass fuselage covering must have a metal ground plane with a 6" (152.4 mm) minimum radius. This could be as simple as aluminum foil cemented inside wood or stiff fiberglass skin, or a doubler plate on a fabric covered aircraft. Such a ground plane should be either well bonded to the airframe, or well insulated from it, to prevent noise problems or erratic operation. Antenna mounting hardware must electrically connect the ground plane to the antenna.

A doubler plate will be needed for an airworthy Installation on most aircraft. Check the airworthiness regulations of the country of aircraft registry for acceptable mounting methods.

Figure 2-3 illustrates the antenna mounted and the necessary minimum clearances. Remove all oxidation, paint, or other finish to permit good electrical contact between the antenna base and the aircraft. Electrical ground will be carried by the mounting hardware.

DO NOT PAINT. The antenna should not be painted or coated with any other finish.

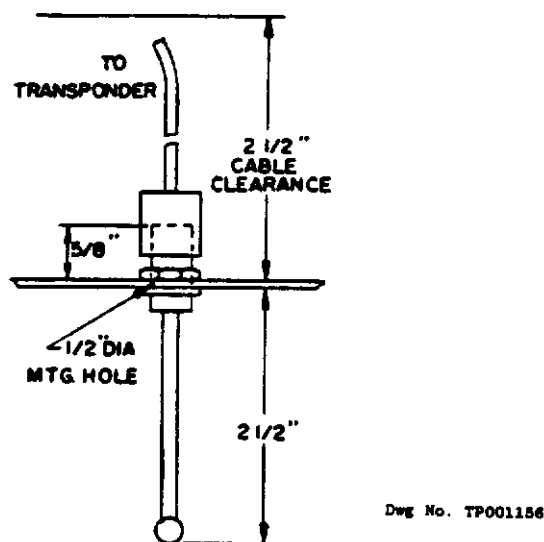

FIGURE 2-3. AT 150 ANTENNA MOUNTING

2.4.2 Antenna Extension Cable

The Installation Kit provides two UG-88U BNC connectors for fabrication of the antenna extension cable. The total length of this cable should not exceed 9 feet (2.7m). Should a cable of greater length be required, a coaxial cable type should be selected whose attenuation does not exceed 2 dB over the entire length.

2.5 ELECTRICAL INSTALLATION

2.5.1 Power And Interconnect Cable

The Installation Kit provides an 18 pin Molex connector along with sufficient pins for fabrication of the power and interconnect cable. Figure 2-4 presents the electrical connections and Figure 2-5 presents a system orientation diagram.

All signal leads should be 22AWG. A+ and ground leads should be 16 AWG. The ground lead should be connected directly to airframe ground.

A 1.5 amp circuit breaker should be provided between the unit and the aircraft power bus.

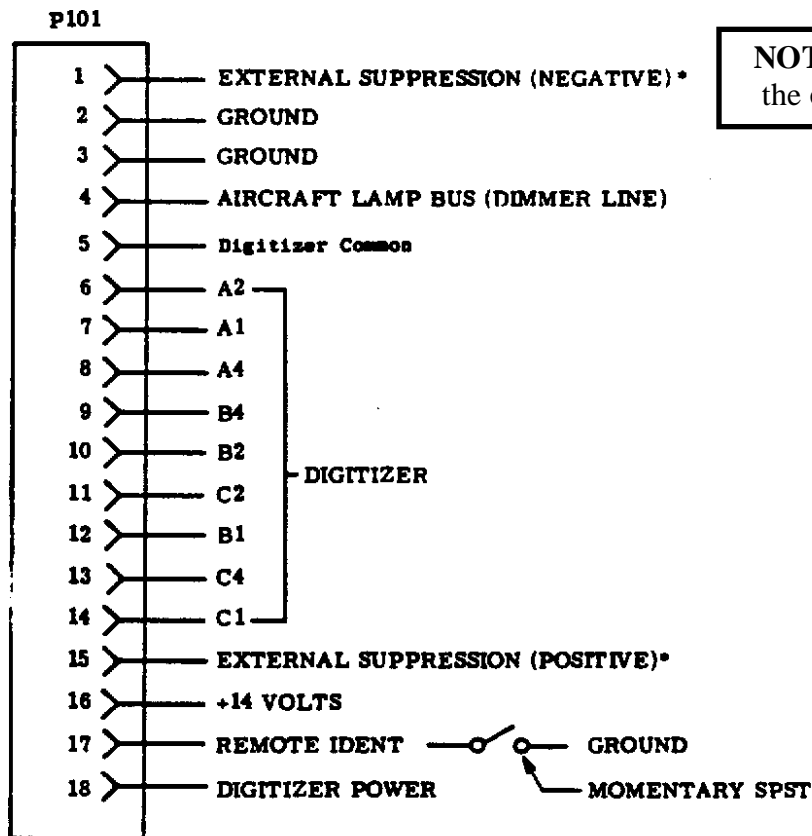

NOTE: Pin 1 is nearest the center of the radio.

*TRANSMISSION MAY BE SUPPRESSED BY EITHER:
a) GROUNDING PIN 1 OR b) APPLYING A POSITIVE VOLTAGE TO PIN 15

Dwg No. TP001158A

FIGURE 2-4 POWER AND INTERCONNECT CABLE

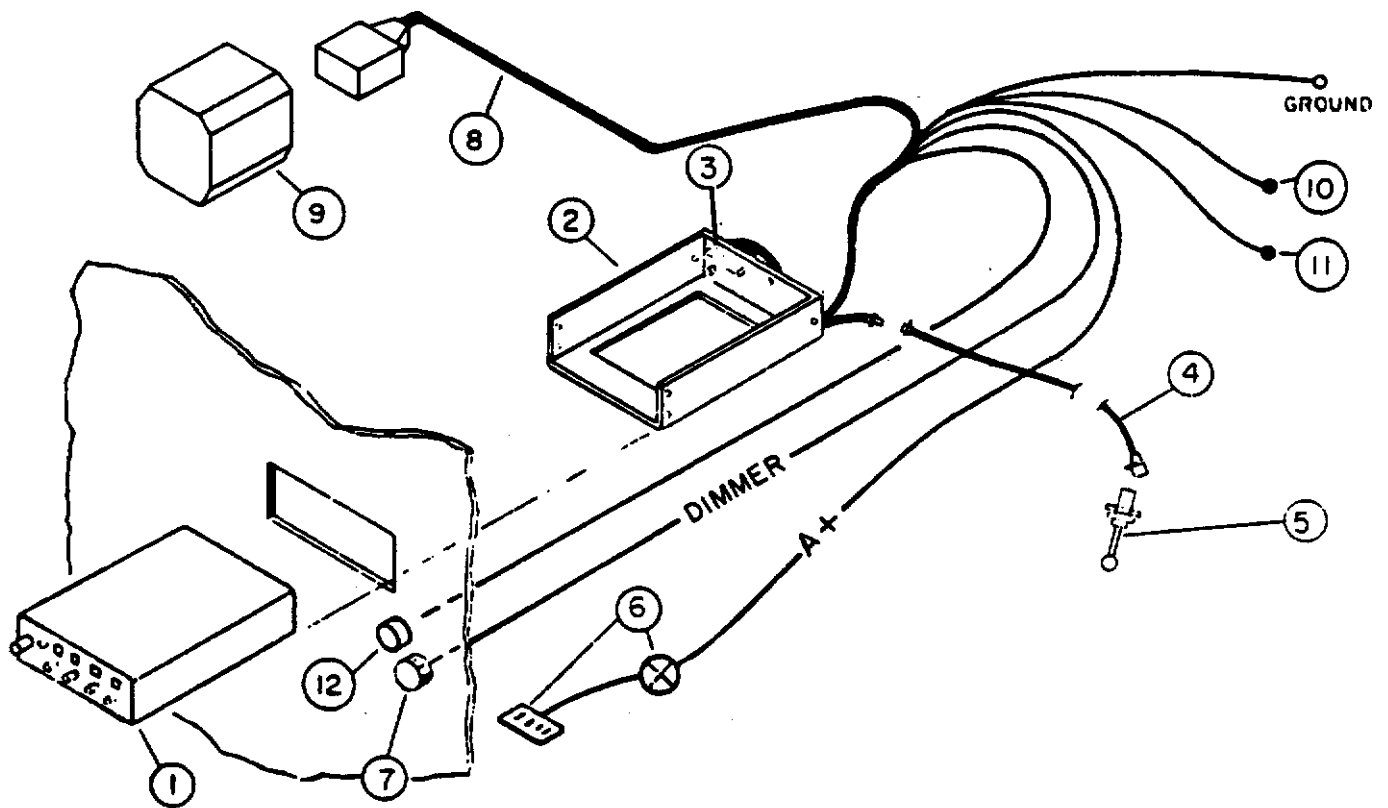

- | | |
|--|------------------------------|
| 1. Transponder | 7. Panel Lamp Dimmer |
| 2. Mounting Tray with Antenna Cable Assy | 8. Altitude Digitizer Cable |
| 3. Power Connector | 9. Altitude Digitizer |
| 4. Antenna Cable Extension | 10. External Suppression (+) |
| 5. Antenna | 11. External Suppression (-) |
| 6. Power Supply Bus and Circuit Breaker | 12. Remote IDENT |

FIGURE 2-5. ORIENTATION DIAGRAM

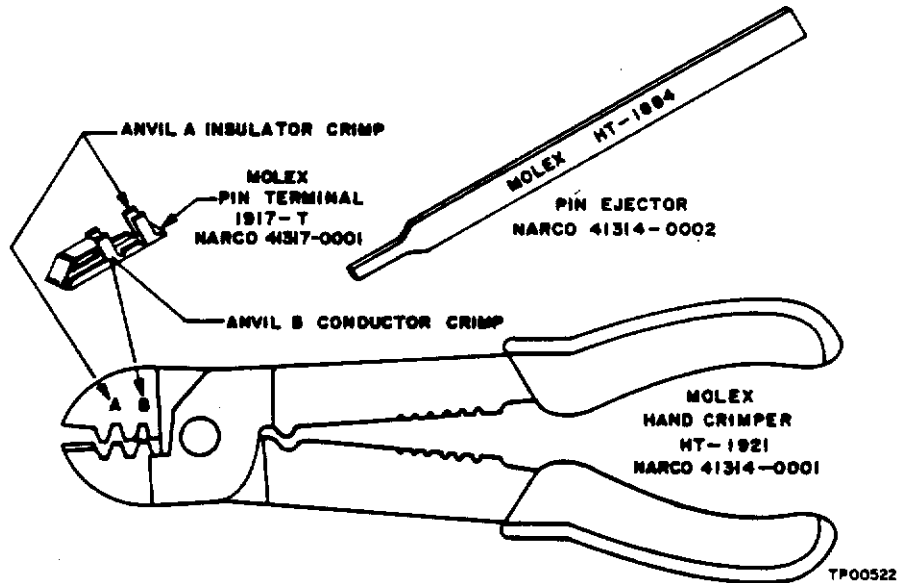

FIGURE 2-6. CRIMPING TOOL

2.5.2 Cable Fabrication

1. Strip wire 5/32" for PIN Terminal No. 1917-T.
2. Open tool (Engraved side toward you), from the opposite side, place the conductor tab section of the pin on Anvil B, Close tool slightly until the tabs touch the female jaw).
3. Insert stripped conductor until insulation is level with outside of jaw. Crimp by squeezing handles together until jaws are fully closed or sufficient crimp is made.
4. Move lead and pin to Anvil A. Crimp again until jaws are closed or sufficient crimp is made.
5. If necessary, straighten pin while still being held in the jaw.
6. Insertion
 - a. The PIN terminal may now be inserted into the desired pin location in the translucent connector housing. The pin cannot be inserted upside down. Right-side-up it slides in effortlessly. Be sure to push it all the way in, until a "click" can be felt, heard, or even seen by turning the translucent housing over.
 - b. There is no necessity to pull back on the lead itself except to test for the "locking feature", and then only with a moderate pull.

2.5.2 Continued

7. Extraction

- a. If a pin is erroneously inserted into the wrong housing position, or if at some later time a circuit change is desired, the pin can be removed easily. Slip the flat narrow blade portion of the tool into the mating side of the housing, under the pin. By holding the housing upside down one can see the blade slide in, up to the stop. This action picks up the locking key and allows the lead and pin to slip out of its position using a light pulling action on the lead. Neither pin nor position has been damaged allowing re-insertion in the same or another position.

8. Crimping with Pliers

The lead PIN Terminal connection using the Molex hand crimper provides a superior connection than with pliers. However, with care, a satisfactory connection can be made without the crimper.

- a. Strip wire 5/32" for PIN Terminal 1917-T.
- b. Using needle nose pliers, fold over conductor tabs firmly onto the conductor, one side then the other.
- c. Repeat step 2 for the Insulator tabs.

2.5.3 Pilot Lamps

Pilot lamp 14/28V OPERATION

The AT155 contain an external 14/28 vdc switch for this purpose. The switch, for proper lamp brilliance, should be set to agree with that of the aircraft's bus voltage.

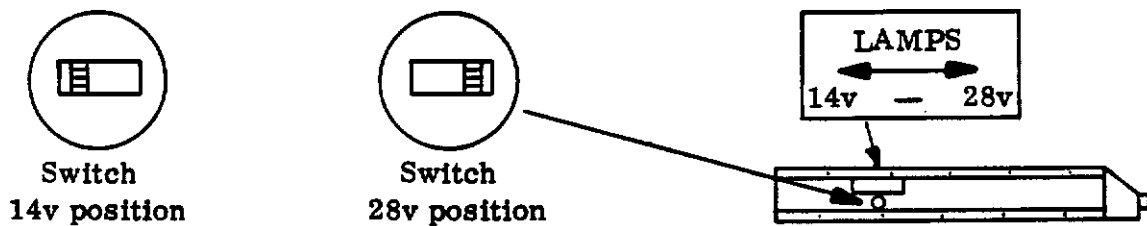

FIGURE 2-7. PILOT LAMP CONVERSION (SWITCH)

2.5.4 External Suppression

The AT155 transponder may be externally suppressed by other avionics equipment whose transmissions may be interfered with by simultaneous AT155 transmissions. P101-15 may be connected to equipment that supply positive suppression pulses. P101-1 may be connected to equipment that supply negative suppression pulses.

In aircraft equipped with dual transponders, P101-1 of both transponders may be connected to a remote SPDT switch which will alternately suppress the transponders by placing the appropriate P101-1 at ground potential. This switch may be located at any convenient place in the cockpit and labeled appropriately.

2.5.5 Remote IDENT

P101-17 provides for the connection of remote IDENT switch. This switch should be a momentary SPST type and connected such that activation places P101-17 at ground potential. This switch may be located at any convenient place in the cockpit and labeled appropriately.

2.5.6 Altitude Digitizer

P101 pins 5 through 14 provide for the connection of an altitude digitizer. The altitude digitizer, sensing atmospheric pressure, converts pressure/altitude information into digitized altitude data. This data is then transmitted to the control center by the transponder. Narco recommends the Model AR 850 for this application.

2.6 POST INSTALLATION TESTS

To certify the installation, FAA Form 337 must be completed. In addition, weight and balance or any operating limitations must be entered into the aircraft logbook. Refer to the current Federal Aviation Regulations for any additional requirements.

Weight	1.5 lbs. (0.68 kg)	
Power Requirements	13.75 VDC	27.5VDC
Standby	210mA	125mA
Transmit	1.2 A	530mA
Pilot Lamps	220mA	90mA

2.6.1 Preflight Tests

A. A preflight test should be performed using an ATC-600A Transponder and DME test set or equivalent. The test set should be set-up as described in the ATC-600A Operators Manual and following tests should be conducted:

1. Pilot Code
2. Peak Transmitter Power
3. Transmitter Frequency
4. SLS Operation
5. IDENT
6. Percent Reply

B. In the event that an altitude digitizer has been installed, the altitude digitizer manual should be consulted for proper procedures and the following tests should be conducted:

1. Altitude Code
2. Invalid Altitude Code Output

2.6.2 Flight Test

After installation, a flight test should be performed to check overall operation and system compatibility.

A. Range Test

1. The AT155 should furnish a strong and stable return signal to an interrogating radar facility that is 50 NM away when the aircraft is flying at 6000 feet. At this altitude and distance, fly a flat circle while having a FAA station monitor the transponder return signal. There should be no more than two sweeps of the interrogating radar without a return response.

B. Surveillance Approach

1. Perform an approach to a runway of an airport starting at least 10 NM from the airport served by Airport Surveillance Radar (ASR) having an Air Traffic Control Radar Beacon System (ATCRBS) facility. Alternately, a simulated approach and letdown may be made along a path parallel to, but separated, three to four miles from a vertical plane through the location of the ASR facility. The approach should be made at the normal rate of descent and normal approach and landing configuration for the aircraft and should continue down to an altitude of 200 feet. Not more than one "drop out" should occur for any 10 radar sweeps during final approach.

C. Electromagnetic Compatibility

1. The transponder should not cause the performance of other systems aboard the aircraft to be degraded below their normal capability and transponder operation should not be adversely affected by other equipment.

2.7 AIRCRAFT LICENSE REQUIREMENTS

The AT155 installation must comply with current FCC transmitter licensing requirements. To find out specific details on whether a particular installation requires licensing contact the FCC at 800-322-1117.

If an aircraft license is required, make application for a license on FCC form 404, Application for Aircraft Radio Station License.

The aircraft owner accepts all responsibility for obtaining the proper licensing before using the AT155

This equipment has been type accepted by the FCC and entered in their list of type accepted equipment under the FCC identifier "A9SAT155".

APPENDIX A

A.1 ENVIRONMENTAL QUALIFICATION FORM

NOTE : A COPY OF THIS FORM IS TO BE FILED WITH THE OWNER'S AVIONICS RECORDS.

NOMENCLATURE : TRANSPONDER
MODEL : AT155
MANUFACTURER : Narco Avionics Inc.
ADDRESS : 270 Commerce Drive
Fort Washington, PA 19034
USA

CONDITIONS	DO-160C SECTION, PARAGRAPH#	DESCRIPTION OF CONDUCTED TESTS
Temperature and Altitude	4.0	Equipment tested to category "A1C1"
Ground Survival Low Temperature	4.5.1	-55°C
Operating Low Temperature	4.5.1	-20°C
Ground Survival High Temperature	4.5.2	+85°C
Short-Time High Operating Temperature	4.5.2	+75°C
Operating High Temperature	4.5.3	+55°C
In Flight Loss of Cooling	4.5.4	Equipment tested to category "V", Greater than 30 Minutes
Altitude	4.6.1	35,000 feet (10,668 meters)
Decompression	4.6.2	8,000 feet to 35,000 feet Δ within 15 seconds, then maintained for 10 minute minimum duration.
Overpressure	4.6.3	-15,000 feet for 10 minutes
Temperature Variation	5.0	Equipment tested to category "C".
Humidity	6.0	Equipment tested to category "A".
Operational Shocks and Crash Safety	7.0	Equipment tested to operational and crash safety tests.
Operational	7.2	
Crash Safety	7.3	
Vibration	8.0	Equipment tested without shock mounts to Categories M, N and B (DO-160C Table 8-1)
Explosion	9.0	Equipment identified as Category "X", no test required.
Waterproofness	10.0	Equipment identified as Category "X", no test required.
Fluids Susceptibility	11.0	Equipment identified as Category "X", no test required.
Sand and Dust	12.0	Equipment identified as Category "X", no test required.
Fungus	13.0	Equipment identified as Category "X", no test required.
Salt Spray	14.0	Equipment identified as Category "X", no test required.
Magnetic Effect	15.0	Equipment tested to Category "Z"
Power Input	16.0	Equipment tested to Category "B"
Voltage Spike	17.0	Equipment tested to Category "B"
Audio Frequency Susceptibility	18.0	Equipment tested to Category "B"
Induced Signal Susceptibility	19.0	Equipment tested to Category "A"
Radio Frequency Susceptibility	20.0	Equipment tested to Category "T"
Radio Frequency Emission	21.0	Equipment tested to Category "B"
Lightning Induced Transient Susceptibility	22.0	Equipment identified as Category "X", no test required.
Lightning Direct Effects Test	23.0	Equipment identified as Category "X", no test required.
Icing	24.0	Equipment identified as Category "X", no test required.
Other Test		Fire resistance tests were conducted in accordance with Federal Aviation Regulations Part 15, Appendix F.

A.2 CONTINUED AIRWORTHINESS

Other than for regulatory periodic functional checks, the AT155 does not require periodic maintenance. If the AT155 exhibits non-conformal operation, the AT155 should be checked at a qualified service facility.

INSTALLATION
MANUAL REVISION HISTORY

MANUAL REVISION HISTORY

Page Number	Revision Level	Date
i	REV 1.0	MAY, 2002
ii	REV 1.0	MAY, 2002
1-1	REV 1.0	MAY, 2002
1-2	REV 1.0	MAY, 2002
1-3	REV 1.0	MAY, 2002
1-4	REV 1.0	MAY, 2002
1-5	REV 1.0	MAY, 2002
1-6	REV 1.0	MAY, 2002
2-1	REV 1.0	MAY, 2002
2-2	REV 1.0	MAY, 2002
2-3	REV 1.0	MAY, 2002
2-4	REV 1.0	MAY, 2002
2-5	REV 1.0	MAY, 2002
2-6	REV 1.0	MAY, 2002
2-7	REV 1.0	MAY, 2002
2-8	REV 1.0	MAY, 2002
2-9	REV 1.0	MAY, 2002
2-10	REV 1.0	MAY, 2002
2-11	REV 1.0	MAY, 2002
2-12	REV 1.0	MAY, 2002
2-13	REV 1.0	MAY, 2002
2-14	REV 1.0	MAY, 2002
A-1	REV 1.0	MAY, 2002
A-2	REV 1.0	MAY, 2002
R-1	REV 1.0	MAY, 2002