

DAQ M Series

NI USB-621x User Manual

Bus-Powered M Series USB Devices

Worldwide Technical Support and Product Information

ni.com

National Instruments Corporate Headquarters

11500 North Mopac Expressway Austin, Texas 78759-3504 USA Tel: 512 683 0100

Worldwide Offices

Australia 1800 300 800, Austria 43 0 662 45 79 90 0, Belgium 32 0 2 757 00 20, Brazil 55 11 3262 3599, Canada 800 433 3488, China 86 21 6555 7838, Czech Republic 420 224 235 774, Denmark 45 45 76 26 00, Finland 385 0 9 725 725 11, France 33 0 1 48 14 24 24, Germany 49 0 89 741 31 30, India 91 80 41190000, Israel 972 0 3 6393737, Italy 39 02 413091, Japan 81 3 5472 2970, Korea 82 02 3451 3400, Lebanon 961 0 1 33 28 28, Malaysia 1800 887710, Mexico 01 800 010 0793, Netherlands 31 0 348 433 466, New Zealand 0800 553 322, Norway 47 0 66 90 76 60, Poland 48 22 3390150, Portugal 351 210 311 210, Russia 7 095 783 68 51, Singapore 1800 226 5886, Slovenia 386 3 425 4200, South Africa 27 0 11 805 8197, Spain 34 91 640 0085, Sweden 46 0 8 587 895 00, Switzerland 41 56 200 51 51, Taiwan 886 02 2377 2222, Thailand 662 278 6777, United Kingdom 44 0 1635 523545

For further support information, refer to the *Technical Support and Professional Services* appendix. To comment on National Instruments documentation, refer to the National Instruments Web site at ni.com/info and enter the info code `feedback`.

Important Information

Warranty

The USB-6210, USB-6211, USB-6215, and USB-6218 devices are warranted against defects in materials and workmanship for a period of three years from the date of shipment, as evidenced by receipts or other documentation. National Instruments will, at its option, repair or replace equipment that proves to be defective during the warranty period. This warranty includes parts and labor.

The media on which you receive National Instruments software are warranted not to fail to execute programming instructions, due to defects in materials and workmanship, for a period of 90 days from date of shipment, as evidenced by receipts or other documentation. National Instruments will, at its option, repair or replace software media that do not execute programming instructions if National Instruments receives notice of such defects during the warranty period. National Instruments does not warrant that the operation of the software shall be uninterrupted or error free.

A Return Material Authorization (RMA) number must be obtained from the factory and clearly marked on the outside of the package before any equipment will be accepted for warranty work. National Instruments will pay the shipping costs of returning to the owner parts which are covered by warranty.

National Instruments believes that the information in this document is accurate. The document has been carefully reviewed for technical accuracy. In the event that technical or typographical errors exist, National Instruments reserves the right to make changes to subsequent editions of this document without prior notice to holders of this edition. The reader should consult National Instruments if errors are suspected. In no event shall National Instruments be liable for any damages arising out of or related to this document or the information contained in it.

EXCEPT AS SPECIFIED HEREIN, NATIONAL INSTRUMENTS MAKES NO WARRANTIES, EXPRESS OR IMPLIED, AND SPECIFICALLY DISCLAIMS ANY WARRANTY OF MERCHANTABILITY OR FITNESS FOR A PARTICULAR PURPOSE. CUSTOMER'S RIGHT TO RECOVER DAMAGES CAUSED BY FAULT OR NEGLIGENCE ON THE PART OF NATIONAL INSTRUMENTS SHALL BE LIMITED TO THE AMOUNT THEREOF PAID BY THE CUSTOMER. NATIONAL INSTRUMENTS WILL NOT BE LIABLE FOR DAMAGES RESULTING FROM LOSS OF DATA, PROFITS, USE OF PRODUCTS, OR INCIDENTAL OR CONSEQUENTIAL DAMAGES, EVEN IF ADVISED OF THE POSSIBILITY THEREOF. This limitation of the liability of National Instruments will apply regardless of the form of action, whether in contract or tort, including negligence. Any action against National Instruments must be brought within one year after the cause of action accrues. National Instruments shall not be liable for any delay in performance due to causes beyond its reasonable control. The warranty provided herein does not cover damages, defects, malfunctions, or service failures caused by owner's failure to follow the National Instruments installation, operation, or maintenance instructions; owner's modification of the product; owner's abuse, misuse, or negligent acts; and power failure or surges, fire, flood, accident, actions of third parties, or other events outside reasonable control.

Copyright

Under the copyright laws, this publication may not be reproduced or transmitted in any form, electronic or mechanical, including photocopying, recording, storing in an information retrieval system, or translating, in whole or in part, without the prior written consent of National Instruments Corporation.

National Instruments respects the intellectual property of others, and we ask our users to do the same. NI software is protected by copyright and other intellectual property laws. Where NI software may be used to reproduce software or other materials belonging to others, you may use NI software only to reproduce materials that you may reproduce in accordance with the terms of any applicable license or other legal restriction.

Trademarks

National Instruments, NI, ni.com, and LabVIEW are trademarks of National Instruments Corporation. Refer to the *Terms of Use* section on ni.com/legal for more information about National Instruments trademarks.

FireWire® is the registered trademark of Apple Computer, Inc. Other product and company names mentioned herein are trademarks or trade names of their respective companies.

Members of the National Instruments Alliance Partner Program are business entities independent from National Instruments and have no agency, partnership, or joint-venture relationship with National Instruments.

Patents

For patents covering National Instruments products, refer to the appropriate location: **Help»Patents** in your software, the `patents.txt` file on your CD, or ni.com/patents.

WARNING REGARDING USE OF NATIONAL INSTRUMENTS PRODUCTS

(1) NATIONAL INSTRUMENTS PRODUCTS ARE NOT DESIGNED WITH COMPONENTS AND TESTING FOR A LEVEL OF RELIABILITY SUITABLE FOR USE IN OR IN CONNECTION WITH SURGICAL IMPLANTS OR AS CRITICAL COMPONENTS IN ANY LIFE SUPPORT SYSTEMS WHOSE FAILURE TO PERFORM CAN REASONABLY BE EXPECTED TO CAUSE SIGNIFICANT INJURY TO A HUMAN.

(2) IN ANY APPLICATION, INCLUDING THE ABOVE, RELIABILITY OF OPERATION OF THE SOFTWARE PRODUCTS CAN BE IMPAIRED BY ADVERSE FACTORS, INCLUDING BUT NOT LIMITED TO FLUCTUATIONS IN ELECTRICAL POWER SUPPLY, COMPUTER HARDWARE MALFUNCTIONS, COMPUTER OPERATING SYSTEM SOFTWARE FITNESS, FITNESS OF COMPILERS AND DEVELOPMENT SOFTWARE USED TO DEVELOP AN APPLICATION, INSTALLATION ERRORS, SOFTWARE AND HARDWARE COMPATIBILITY PROBLEMS, MALFUNCTIONS OR FAILURES OF ELECTRONIC MONITORING OR CONTROL DEVICES, TRANSIENT FAILURES OF ELECTRONIC SYSTEMS (HARDWARE AND/OR SOFTWARE), UNANTICIPATED USES OR MISUSES, OR ERRORS ON THE PART OF THE USER OR APPLICATIONS DESIGNER (ADVERSE FACTORS SUCH AS THESE ARE HEREAFTER COLLECTIVELY TERMED "SYSTEM FAILURES"). ANY APPLICATION WHERE A SYSTEM FAILURE WOULD CREATE A RISK OF HARM TO PROPERTY OR PERSONS (INCLUDING THE RISK OF BODILY INJURY AND DEATH) SHOULD NOT BE RELIANT SOLELY UPON ONE FORM OF ELECTRONIC SYSTEM DUE TO THE RISK OF SYSTEM FAILURE. TO AVOID DAMAGE, INJURY, OR DEATH, THE USER OR APPLICATION DESIGNER MUST TAKE REASONABLY PRUDENT STEPS TO PROTECT AGAINST SYSTEM FAILURES, INCLUDING BUT NOT LIMITED TO BACK-UP OR SHUT DOWN MECHANISMS. BECAUSE EACH END-USER SYSTEM IS CUSTOMIZED AND DIFFERS FROM NATIONAL INSTRUMENTS' TESTING PLATFORMS AND BECAUSE A USER OR APPLICATION DESIGNER MAY USE NATIONAL INSTRUMENTS PRODUCTS IN COMBINATION WITH OTHER PRODUCTS IN A MANNER NOT EVALUATED OR CONTEMPLATED BY NATIONAL INSTRUMENTS, THE USER OR APPLICATION DESIGNER IS ULTIMATELY RESPONSIBLE FOR VERIFYING AND VALIDATING THE SUITABILITY OF NATIONAL INSTRUMENTS PRODUCTS WHENEVER

NATIONAL INSTRUMENTS PRODUCTS ARE INCORPORATED IN A SYSTEM OR APPLICATION, INCLUDING, WITHOUT LIMITATION, THE APPROPRIATE DESIGN, PROCESS AND SAFETY LEVEL OF SUCH SYSTEM OR APPLICATION.

Contents

About This Manual

Conventions	xiii
Related Documentation.....	xiv
NI-DAQmx for Windows.....	xiv
LabVIEW	xiv
LabWindows™/CVI™.....	xv
Measurement Studio.....	xv
ANSI C without NI Application Software	xv
.NET Languages without NI Application Software	xvi
Device Documentation and Specifications.....	xvi
Training Courses	xvi
Technical Support on the Web	xvi

Chapter 1

Getting Started

Installing NI-DAQmx	1-2
Installing Other Software.....	1-2
Installing the Hardware.....	1-3
Device Pinouts	1-3
Device Specifications	1-3
Device Accessories	1-3

Chapter 2

DAQ System Overview

DAQ Hardware	2-1
DAQ-STC2.....	2-2
Calibration Circuitry.....	2-2
Signal Conditioning	2-3
Sensors and Transducers	2-3
Programming Devices in Software	2-4

Chapter 3

Connector Information

I/O Connector Signal Descriptions	3-1
+5 V Power	3-2
+5 V Power as an Output	3-2
+5 V Power as an Input	3-3

Chapter 4

Analog Input

Analog Input Circuitry	4-1
Analog Input Range.....	4-2
Analog Input Ground-Reference Settings	4-3
Configuring AI Ground-Reference Settings in Software.....	4-5
Multichannel Scanning Considerations.....	4-6
Use Low Impedance Sources.....	4-6
Carefully Choose the Channel Scanning Order	4-7
Avoid Switching from a Large to a Small Input Range	4-7
Insert Grounded Channel between Signal Channels	4-7
Minimize Voltage Step between Adjacent Channels	4-8
Avoid Scanning Faster Than Necessary	4-8
Example 1	4-8
Example 2	4-9
Analog Input Data Acquisition Methods.....	4-9
Software-Timed Acquisitions	4-9
Hardware-Timed Acquisitions.....	4-9
Buffered.....	4-10
Non-Buffered.....	4-10
Analog Input Digital Triggering.....	4-10
Field Wiring Considerations.....	4-11
Analog Input Timing Signals	4-11
AI Sample Clock Signal.....	4-14
Using an Internal Source	4-15
Using an External Source	4-15
Routing AI Sample Clock Signal to an Output Terminal.....	4-15
Other Timing Requirements	4-15
AI Sample Clock Timebase Signal	4-16
AI Convert Clock Signal.....	4-16
Using an Internal Source	4-17
Using an External Source	4-17
Routing AI Convert Clock Signal to an Output Terminal.....	4-17
Using a Delay from Sample Clock to Convert Clock	4-17
Other Timing Requirements	4-18
AI Convert Clock Timebase Signal	4-20
AI Hold Complete Event Signal	4-21
AI Start Trigger Signal.....	4-21
Using a Digital Source.....	4-21
Routing AI Start Trigger to an Output Terminal	4-21
AI Reference Trigger Signal.....	4-22
Using a Digital Source.....	4-23
Routing AI Reference Trigger Signal to an Output Terminal	4-23

AI Pause Trigger Signal	4-23
Using a Digital Source	4-23
Getting Started with AI Applications in Software	4-24

Chapter 5

Connecting AI Signals on the USB-6210/6211 Devices

Connecting Floating Signal Sources	5-3
What Are Floating Signal Sources?	5-3
When to Use Differential Connections with Floating Signal Sources	5-3
When to Use Referenced Single-Ended (RSE) Connections with Floating Signal Sources	5-3
When to Use Non-Referenced Single-Ended (NRSE) Connections with Floating Signal Sources	5-4
Using Differential Connections for Floating Signal Sources	5-5
Using Non-Referenced Single-Ended (NRSE) Connections for Floating Signal Sources	5-8
Using Referenced Single-Ended (RSE) Connections for Floating Signal Sources	5-9
Connecting Ground-Referenced Signal Sources	5-9
What Are Ground-Referenced Signal Sources?	5-9
When to Use Differential Connections with Ground-Referenced Signal Sources	5-10
When to Use Non-Referenced Single-Ended (NRSE) Connections with Ground-Referenced Signal Sources	5-10
When to Use Referenced Single-Ended (RSE) Connections with Ground-Referenced Signal Sources	5-11
Using Differential Connections for Ground-Referenced Signal Sources	5-12
Using Non-Referenced Single-Ended (NRSE) Connections for Ground-Referenced Signal Sources	5-13

Chapter 6

Connecting AI Signals on the USB-6215/6218 Devices

Differential Measurements	6-1
Differential Pairs	6-1
Referenced Single-Ended (RSE) Measurements	6-3
Non-Referenced Single-Ended (NRSE) Measurements	6-4

Chapter 7 Analog Output

Analog Output Circuitry	7-1
AO Range	7-2
Minimizing Glitches on the Output Signal.....	7-2
Analog Output Data Generation Methods	7-2
Software-Timed Generations	7-2
Hardware-Timed Generations.....	7-2
Analog Output Digital Triggering	7-4
Connecting Analog Output Signals.....	7-4
Analog Output Timing Signals.....	7-5
AO Start Trigger Signal	7-5
Using a Digital Source.....	7-5
Routing AO Start Trigger Signal to an Output Terminal	7-6
AO Pause Trigger Signal	7-6
Using a Digital Source.....	7-6
AO Sample Clock Signal	7-7
Using an Internal Source	7-7
Using an External Source	7-7
Routing AO Sample Clock Signal to an Output Terminal	7-7
Other Timing Requirements	7-7
AO Sample Clock Timebase Signal.....	7-8
Getting Started with AO Applications in Software.....	7-9

Chapter 8 Digital I/O

Static DIO.....	8-2
I/O Protection	8-2
Increasing Current Drive	8-2
Connecting Digital I/O Signals	8-3
Getting Started with DIO Applications in Software.....	8-4

Chapter 9 Counters

Counter Input Applications	9-2
Counting Edges	9-2
Single Point (On-Demand) Edge Counting	9-2
Buffered (Sample Clock) Edge Counting.....	9-3
Non-Cumulative Buffered Edge Counting	9-4
Controlling the Direction of Counting.....	9-4

Pulse-Width Measurement	9-5
Single Pulse-Width Measurement.....	9-5
Buffered Pulse-Width Measurement.....	9-5
Period Measurement	9-6
Single Period Measurement	9-7
Buffered Period Measurement	9-7
Semi-Period Measurement	9-9
Single Semi-Period Measurement.....	9-9
Buffered Semi-Period Measurement.....	9-9
Frequency Measurement	9-10
Method 1—Measure Low Frequency with One Counter.....	9-10
Method 1b—Measure Low Frequency with One Counter (Averaged).....	9-11
Method 2—Measure High Frequency with Two Counters.....	9-11
Method 3—Measure Large Range of Frequencies Using Two Counters	9-12
Choosing a Method for Measuring Frequency	9-13
Position Measurement	9-15
Measurements Using Quadrature Encoders	9-15
Measurements Using Two Pulse Encoders	9-17
Two-Signal Edge-Separation Measurement.....	9-18
Single Two-Signal Edge-Separation Measurement	9-18
Buffered Two-Signal Edge-Separation Measurement	9-19
Counter Output Applications	9-20
Simple Pulse Generation	9-20
Single Pulse Generation	9-20
Single Pulse Generation with Start Trigger	9-20
Retriggerable Single Pulse Generation	9-21
Pulse Train Generation.....	9-22
Continuous Pulse Train Generation	9-22
Frequency Generation	9-23
Using the Frequency Generator	9-23
Frequency Division	9-24
Pulse Generation for ETS	9-24
Counter Timing Signals	9-25
Counter n Source Signal.....	9-26
Routing a Signal to Counter n Source.....	9-26
Routing Counter n Source to an Output Terminal	9-26
Counter n Gate Signal	9-27
Routing a Signal to Counter n Gate	9-27
Routing Counter n Gate to an Output Terminal.....	9-27
Counter n Aux Signal	9-27
Routing a Signal to Counter n Aux	9-27

Counter <i>n</i> A, Counter <i>n</i> B, and Counter <i>n</i> Z Signals	9-28
Routing Signals to A, B, and Z Counter Inputs	9-28
Counter <i>n</i> Up_Down Signal	9-28
Counter <i>n</i> HW Arm Signal	9-28
Routing Signals to Counter <i>n</i> HW Arm Input	9-28
Counter <i>n</i> Internal Output and Counter <i>n</i> TC Signals	9-29
Routing Counter <i>n</i> Internal Output to an Output Terminal	9-29
Frequency Output Signal	9-29
Routing Frequency Output to a Terminal	9-29
Default Counter/Timer Pinouts	9-29
Counter Triggering	9-31
Arm Start Trigger	9-31
Start Trigger	9-31
Pause Trigger	9-31
Other Counter Features	9-32
Sample Clock	9-32
Cascading Counters	9-33
Counter Filters	9-33
Prescaling	9-34
Duplicate Count Prevention	9-35
Example Application That Works Correctly	
(No Duplicate Counting)	9-36
Example Application That Works Incorrectly	
(Duplicate Counting)	9-37
Example Application That Prevents Duplicate Count	9-37
Enabling Duplicate Count Prevention in NI-DAQmx	9-38

Chapter 10

PFI

Using PFI Terminals as Timing Input Signals	10-2
Exporting Timing Output Signals Using PFI Terminals	10-3
Using PFI Terminals as Static Digital I/Os	10-3
Connecting PFI Input Signals	10-3
PFI Filters	10-4
I/O Protection	10-6
Programmable Power-Up States	10-6

Chapter 11

Isolation and Digital Isolators

Digital Isolation	11-2
Benefits of an Isolated DAQ Device	11-2
Reducing Common-Mode Noise	11-2
Creating an AC Return Path	11-3
Isolated Systems	11-3
Non-Isolated Systems	11-3

Chapter 12

Digital Routing and Clock Generation

80 MHz Timebase	12-1
20 MHz Timebase	12-1
100 kHz Timebase	12-2

Chapter 13

Bus Interface

USB Signal Streams	13-1
Data Transfer Methods	13-1
USB Signal Stream	13-1
Programmed I/O	13-2
Changing Data Transfer Methods	13-2

Chapter 14

Triggering

Triggering with a Digital Source	14-1
--	------

Appendix A

Device-Specific Information

USB-6210	A-1
USB-6211/6215	A-4
USB 6218	A-7

Appendix B Troubleshooting

Appendix C Technical Support and Professional Services

Glossary

Index

Device Pinouts

Figure A-1.	USB-6210 Pinout	A-2
Figure A-2.	USB-6211/6215 Pinout	A-5
Figure A-3.	USB 6218 Pinout	A-8

About This Manual

The *NI 621x User Manual* contains information about using the National Instruments USB-621x data acquisition (DAQ) devices with NI-DAQmx 8.3 and later. NI 621x devices feature up to 32 analog input (AI) channels, up to two analog output (AO) channels, up to eight lines of digital input (DI), up to eight lines of digital output (DO), and two counters.

Conventions

The following conventions are used in this manual:

<>

Angle brackets that contain numbers separated by an ellipsis represent a range of values associated with a bit or signal name—for example, AO <3..0>.

»

The » symbol leads you through nested menu items and dialog box options to a final action. The sequence **File»Page Setup»Options** directs you to pull down the **File** menu, select the **Page Setup** item, and select **Options** from the last dialog box.



This icon denotes a note, which alerts you to important information.



This icon denotes a caution, which advises you of precautions to take to avoid injury, data loss, or a system crash. When this symbol is marked on a product, refer to the *Read Me First: Safety and Radio-Frequency Interference* document which can be found at ni.com/manuals, for information about precautions to take.

bold

Bold text denotes items that you must select or click in the software, such as menu items and dialog box options. Bold text also denotes parameter names.

italic

Italic text denotes variables, emphasis, a cross-reference, or an introduction to a key concept. Italic text also denotes text that is a placeholder for a word or value that you must supply.

monospace

Text in this font denotes text or characters that you should enter from the keyboard, sections of code, programming examples, and syntax examples. This font is also used for the proper names of disk drives, paths, directories, programs, subprograms, subroutines, device names, functions, operations, variables, filenames, and extensions.

Related Documentation

Each application software package and driver includes information about writing applications for taking measurements and controlling measurement devices. The following references to documents assume you have NI-DAQ 8.3 or later, and where applicable, version 7.0 or later of the NI application software.

NI-DAQmx for Windows

The *NI-DAQmx for USB Devices Getting Started Guide* describes how to install your NI-DAQmx for Windows software, your NI-DAQmx-supported DAQ device, and how to confirm that your device is operating properly. Select **Start»All Programs»National Instruments»NI-DAQ»NI-DAQmx for USB Devices Getting Started**.

The *NI-DAQ Readme* lists which devices are supported by this version of NI-DAQ. Select **Start»All Programs»National Instruments»NI-DAQ»NI-DAQ Readme**.

The *NI-DAQmx Help* contains general information about measurement concepts, key NI-DAQmx concepts, and common applications that are applicable to all programming environments. Select **Start»All Programs»National Instruments»NI-DAQ»NI-DAQmx Help**.

LabVIEW

If you are a new user, use the *Getting Started with LabVIEW* manual to familiarize yourself with the LabVIEW graphical programming environment and the basic LabVIEW features you use to build data acquisition and instrument control applications. Open the *Getting Started with LabVIEW* manual by selecting **Start»All Programs»National Instruments»LabVIEW»LabVIEW Manuals** or by navigating to the `labview\manuals` directory and opening `LV_Getting_Started.pdf`.

Use the *LabVIEW Help*, available by selecting **Help»Search the LabVIEW Help** in LabVIEW, to access information about LabVIEW programming concepts, step-by-step instructions for using LabVIEW, and reference information about LabVIEW VIs, functions, palettes, menus, and

tools. Refer to the following locations on the **Contents** tab of the *LabVIEW Help* for information about NI-DAQmx:

- **Getting Started»Getting Started with DAQ**—Includes overview information and a tutorial to learn how to take an NI-DAQmx measurement in LabVIEW using the DAQ Assistant.
- **VI and Function Reference»Measurement I/O VIs and Functions**—Describes the LabVIEW NI-DAQmx VIs and properties.
- **Taking Measurements**—Contains the conceptual and how-to information you need to acquire and analyze measurement data in LabVIEW, including common measurements, measurement fundamentals, NI-DAQmx key concepts, and device considerations.

LabWindows™/CVI™

The **Data Acquisition** book of the *LabWindows/CVI Help* contains measurement concepts for NI-DAQmx. This book also contains *Taking an NI-DAQmx Measurement in LabWindows/CVI*, which includes step-by-step instructions about creating a measurement task using the DAQ Assistant. In LabWindows/CVI, select **Help»Contents**, then select **Using LabWindows/CVI»Data Acquisition**.

The **NI-DAQmx Library** book of the *LabWindows/CVI Help* contains API overviews and function reference for NI-DAQmx. Select **Library Reference»NI-DAQmx Library** in the *LabWindows/CVI Help*.

Measurement Studio

The *NI Measurement Studio Help* contains function reference, measurement concepts, and a walkthrough for using the Measurement Studio NI-DAQmx .NET and Visual C++ class libraries. This help collection is integrated into the Microsoft Visual Studio .NET documentation. In Visual Studio .NET, select **Help»Contents**.



Note You must have Visual Studio .NET installed to view the *NI Measurement Studio Help*.

ANSI C without NI Application Software

The *NI-DAQmx Help* contains API overviews and general information about measurement concepts. Select **Start»All Programs»National Instruments»NI-DAQmx Help**.

.NET Languages without NI Application Software

The *NI Measurement Studio Help* contains function reference and measurement concepts for using the Measurement Studio NI-DAQmx .NET and Visual C++ class libraries. This help collection is integrated into the Visual Studio .NET documentation. In Visual Studio .NET, select **Help»Contents**.



Note You must have Visual Studio .NET installed to view the *NI Measurement Studio Help*.

Device Documentation and Specifications

The *NI 621x Specifications* contains all specifications for the USB-6210, USB-6211, USB-6215, and USB-6218 M Series devices.

NI-DAQ 7.0 and later includes the Device Document Browser, which contains online documentation for supported DAQ, SCXI, and switch devices, such as help files describing device pinouts, features, and operation, and PDF files of the printed device documents. You can find, view, and/or print the documents for each device using the Device Document Browser at any time by inserting the CD. After installing the Device Document Browser, device documents are accessible from **Start»All Programs»National Instruments»NI-DAQ»Browse Device Documentation**.

Training Courses

If you need more help getting started developing an application with NI products, NI offers training courses. To enroll in a course or obtain a detailed course outline, refer to ni.com/training.

Technical Support on the Web

For additional support, refer to ni.com/support or zone.ni.com.



Note You can download these documents at ni.com/manuals.

DAQ specifications and some DAQ manuals are available as PDFs. You must have Adobe Acrobat Reader with Search and Accessibility 5.0.5 or later installed to view the PDFs. Refer to the Adobe Systems Incorporated Web site at www.adobe.com to download Acrobat Reader. Refer to the National Instruments Product Manuals Library at ni.com/manuals for updated documentation resources.

Getting Started

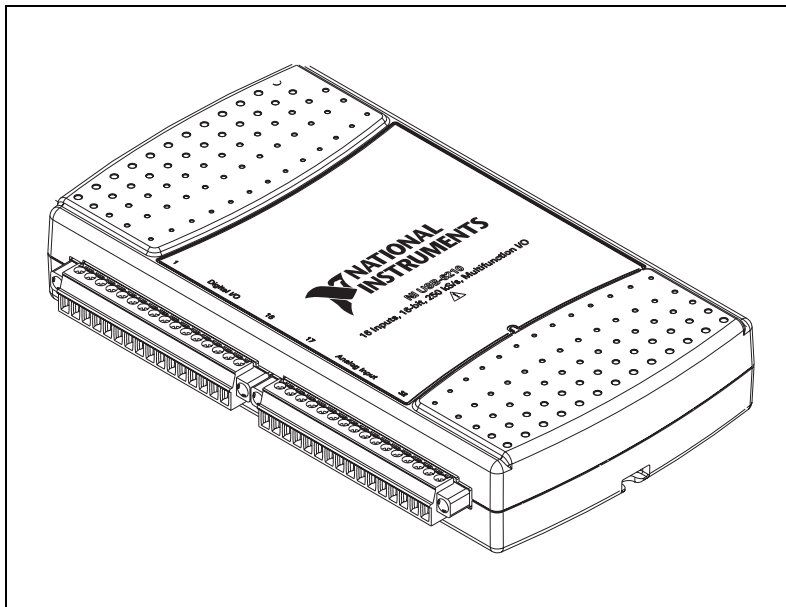

Figure 1-1. USB-6210/6211

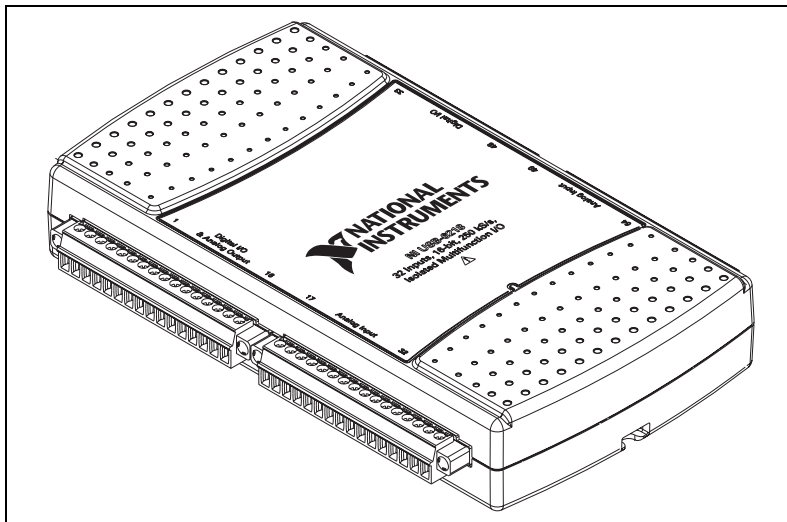

Figure 1-2. USB-6215/6218

NI 621*x* devices feature up to 32 analog input (AI) channels, up to two analog output (AO) channels, 8 lines of digital input (DI), 8 lines of digital output (DO), and two counters. If you have not already installed your device, refer to the *NI-DAQmx for USB Devices Getting Started Guide*. For specifications, refer to the *NI 621*x* Specifications* document on ni.com/manuals.

Before installing your DAQ device, you must install the software you plan to use with the device.

Installing NI-DAQmx

The *NI-DAQmx for USB Devices Getting Started Guide*, which you can download at ni.com/manuals, offers NI-DAQmx users step-by-step instructions for installing software and hardware, configuring channels and tasks, and getting started developing an application.

Installing Other Software

If you are using other software, refer to the installation instructions that accompany your software.

Installing the Hardware

The *NI-DAQmx for USB Devices Getting Started Guide* contains non-software-specific information about how to install USB devices.

Device Pinouts

Refer to Appendix A, *Device-Specific Information*, for NI 621x device pinouts.

Device Specifications

Refer to the *NI 621x Specifications*, available on the NI-DAQ Device Document Browser or ni.com/manuals, for more detailed information about NI 621x devices.

Device Accessories

NI offers a variety of accessories to use with your DAQ device. Refer to Appendix A, *Device-Specific Information*, or ni.com for more information.

DAQ System Overview

Figure 2-1 shows a typical DAQ system, which includes sensors, transducers, signal conditioning devices, cables that connect the various devices to the accessories, the M Series device, programming software, and PC. The following sections cover the components of a typical DAQ system.

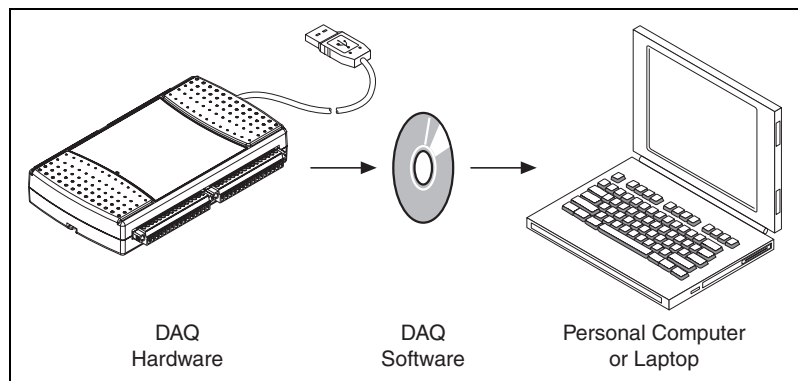

Figure 2-1. Components of a Typical DAQ System

DAQ Hardware

DAQ hardware digitizes signals, performs D/A conversions to generate analog output signals, and measures and controls digital I/O signals. Figure 2-2 features components common to all USB M Series devices.

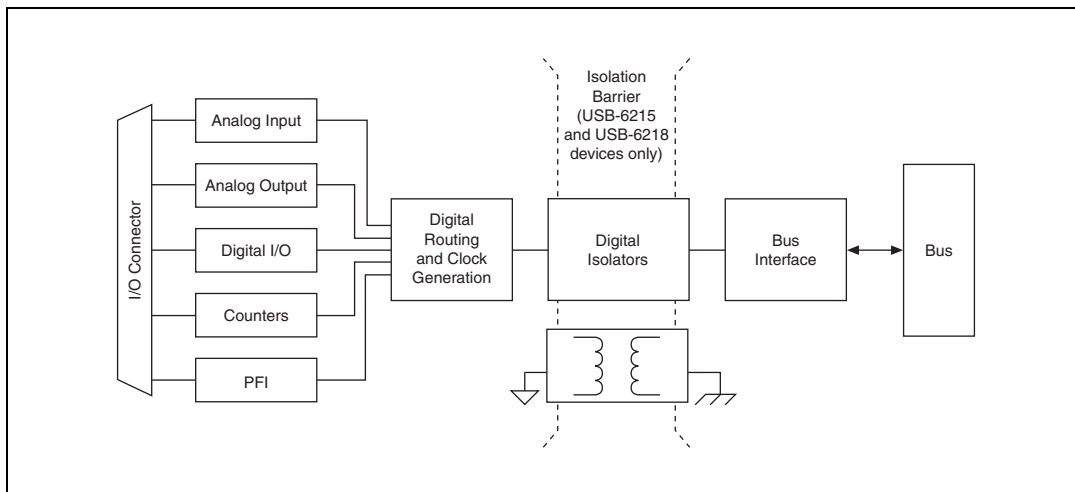

Figure 2-2. USB-621x Block Diagram

DAQ-STC2

The DAQ-STC2 implements a high-performance digital engine for M Series data acquisition hardware. Some key features of this engine include the following:

- Flexible AI and AO sample and convert timing
- Many triggering modes
- Independent AI, AO, and CTR FIFOs
- Generation and routing of internal and external timing signals
- Two flexible 32-bit counter/timer modules with hardware gating
- Static DI and static DO signals
- USB Hi-Speed 2.0 interface
- Up to four USB Signal Streams for acquisition and generation functions

Calibration Circuitry

The M Series analog inputs and outputs have calibration circuitry to correct gain and offset errors. You can calibrate the device to minimize AI and AO errors caused by time and temperature drift at run time. No external circuitry is necessary; an internal reference ensures high accuracy and stability over time and temperature changes.

Factory-calibration constants are permanently stored in an onboard EEPROM and cannot be modified. When you self-calibrate the device, software stores new constants in a user-modifiable section of the EEPROM. To return a device to its initial factory calibration settings, software can copy the factory-calibration constants to the user-modifiable section of the EEPROM. Refer to the *NI-DAQmx Help* or the *LabVIEW 8.x Help* for more information about using calibration constants.

Signal Conditioning

Many sensors and transducers require signal conditioning before a measurement system can effectively and accurately acquire the signal. The front-end signal conditioning system can include functions such as signal amplification, attenuation, filtering, electrical isolation, simultaneous sampling, and multiplexing. In addition, many transducers require excitation currents or voltages, bridge completion, linearization, or high amplification for proper and accurate operation. Therefore, most computer-based measurement systems include some form of signal conditioning in addition to plug-in data acquisition DAQ devices.

Sensors and Transducers

Sensors can generate electrical signals to measure physical phenomena, such as temperature, force, sound, or light. Some commonly used sensors are strain gauges, thermocouples, thermistors, angular encoders, linear encoders, and resistance temperature detectors (RTDs).

To measure signals from these various transducers, you must convert them into a form that a DAQ device can accept. For example, the output voltage of most thermocouples is very small and susceptible to noise. Therefore, you may need to amplify or filter the thermocouple output before digitizing it. The manipulation of signals to prepare them for digitizing is called *signal conditioning*.

For more information about sensors, refer to the following documents.

- For general information about sensors, visit ni.com/sensors.
- If you are using LabVIEW, refer to the *LabVIEW Help* by selecting **Help»Search the LabVIEW Help** in LabVIEW and then navigate to the **Taking Measurements** book on the **Contents** tab.
- If you are using other application software, refer to *Common Sensors* in the *NI-DAQmx Help* or the *LabVIEW 8.x Help*.

Programming Devices in Software

National Instruments measurement devices are packaged with NI-DAQ driver software, an extensive library of functions and VIs you can call from your application software, such as LabVIEW or LabWindows/CVI, to program all the features of your NI measurement devices. Driver software has an application programming interface (API), which is a library of VIs, functions, classes, attributes, and properties for creating applications for your device.

NI-DAQ 7.3 and later includes two NI-DAQ drivers—Traditional NI-DAQ (Legacy) and NI-DAQmx. M Series devices use the NI-DAQmx driver. Each driver has its own API, hardware configuration, and software configuration. Refer to the *NI-DAQmx for USB Devices Getting Started Guide* for more information about the two drivers.

NI-DAQmx includes a collection of programming examples to help you get started developing an application. You can modify example code and save it in an application. You can use examples to develop a new application or add example code to an existing application.

To locate LabVIEW and LabWindows/CVI examples, open the National Instruments Example Finder.

- In LabVIEW, select **Help»Find Examples**.
- In LabWindows/CVI, select **Help»NI Example Finder**.

Measurement Studio, Visual Basic, and ANSI C examples are located in the following directories:

- NI-DAQmx examples for Measurement Studio-supported languages are in the following directories:
 - MeasurementStudio\VCNET\Examples\NIDaq
 - MeasurementStudio\DotNET\Examples\NIDaq
- NI-DAQmx examples for ANSI C are in the NI-DAQ\Examples\DAQmx ANSI C Dev directory

For additional examples, refer to zone.ni.com.

Connector Information

The *I/O Connector Signal Descriptions* and *+5 V Power* sections contain information about NI 621x connectors. Refer to Appendix A, *Device-Specific Information*, for device I/O connector pinouts.

I/O Connector Signal Descriptions

Table 3-1 describes the signals found on the I/O connectors. Not all signals are available on all devices.

Table 3-1. I/O Connector Signals

Signal Name	Reference	Direction	Description
AI GND	—	—	Analog Input Ground —These terminals are the reference point for single-ended AI measurements in RSE mode and the bias current return point for DIFF measurements. All three ground references—AI GND, AO GND, and D GND—are connected on the device.
AI <0..31>	Varies	Input	<p>Analog Input Channels 0 to 31—For single-ended measurements, each signal is an analog input voltage channel. In RSE mode, AI GND is the reference for these signals. In NRSE mode, the reference for each AI <0..31> signal is AI SENSE.</p> <p>For differential measurements, AI 0 and AI 8 are the positive and negative inputs of differential analog input channel 0. Similarly, the following signal pairs also form differential input channels:</p> <p><AI 1, AI 9>, <AI 2, AI 10>, <AI 3, AI 11>, <AI 4, AI 12>, <AI 5, AI 13>, <AI 6, AI 14>, <AI 7, AI 15>, <AI 16, AI 24>, <AI 17, AI 25>, <AI 18, AI 26>, <AI 19, AI 27>, <AI 20, AI 28>, <AI 21, AI 29>, <AI 22, AI 30>, <AI 23, AI 31></p>
AI SENSE	—	Input	Analog Input Sense —In NRSE mode, the reference for each AI <0..31> signal is AI SENSE.
AO <0..1>	AO GND	Output	Analog Output Channels 0 to 1 —These terminals supply the voltage output of AO channels 0 to 1.

Table 3-1. I/O Connector Signals (Continued)

Signal Name	Reference	Direction	Description
AO GND	—	—	Analog Output Ground —AO GND is the reference for AO <0..1>. All three ground references—AI GND, AO GND, and D GND—are connected on the device.
D GND	—	—	Digital Ground —D GND supplies the reference for PFI <0..15>/P0/P1 and +5 V. All three ground references—AI GND, AO GND, and D GND—are connected on the device.
+5 V	D GND	Input or Output	+5 V Power —These terminals provide a +5 V power source or can be used to externally power the PFI outputs.
PFI <0..3>, PFI <8..11>/P0.<0..7>	D GND	Input	Programmable Function Interface or Static Digital Input Channels 0 to 7 —Each PFI terminal can be used to supply an external source for AI, AO, or counter/timer inputs. You also can use these terminals as static digital input lines.
PFI <4..7>, PFI <12..15>/P1.<0..7>	D GND	Output	Programmable Function Interface or Static Digital Output Channels 0 to 7 —You can route many different internal AI, AO, or counter/timer outputs to each PFI terminal. You also can use these terminals as static digital output lines.
NC	—	—	No connect —Do not connect signals to these terminals.

+5 V Power

The +5 V terminals on the I/O connector can be use as either an output or an input. Both terminals are internally connected on the USB-621*x*.

+5 V Power as an Output

Because the USB-621*x* devices are bus powered, there is a 50 mA limit on the *total* current that can be drawn from the +5 V terminals and the digital outputs PFI <4..7> and PFI <12..15>/P1.<0..7>. The USB-621*x* monitors the total current and will drop the voltage on all of the digital outputs and the +5 V terminals if the 50 mA limit is exceeded.

+5 V Power as an Input

If you have high current loads for the digital outputs to drive, you can exceed the 50 mA internal limit by connecting an external +5 V power source to the +5 V terminals. These terminals are protected against undervoltage and overvoltage, and they have a 350 mA self-resetting fuse to protect them from short circuit conditions. If your USB-621x device has more than one +5 V terminal, you can connect the external power supply to one terminal and use the other as a power source.

Analog Input

Figure 4-1 shows the analog input circuitry of NI 621x devices.

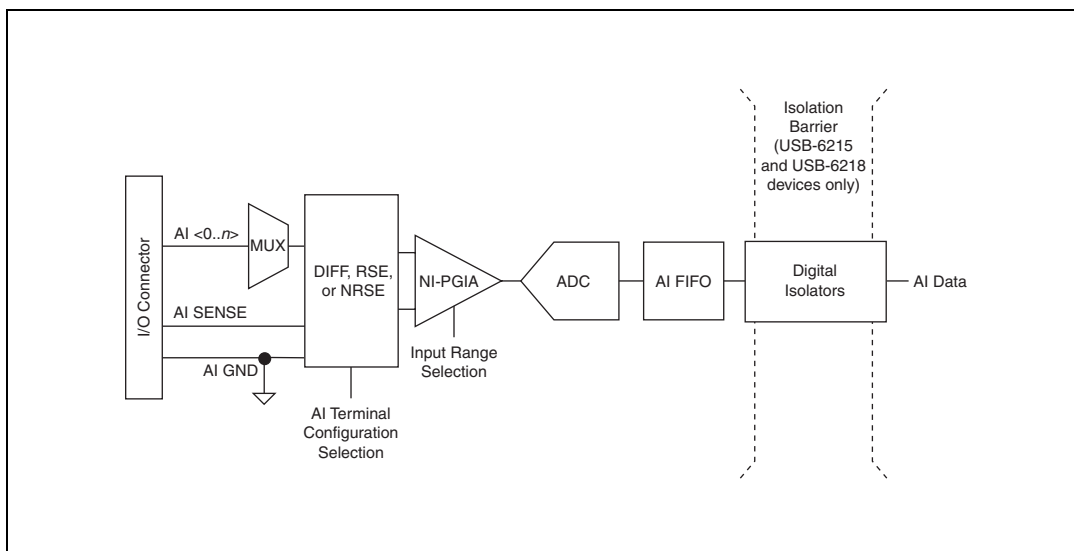

Figure 4-1. M Series Analog Input Circuitry

Analog Input Circuitry

I/O Connector

You can connect analog input signals to the M Series device through the I/O connector. The proper way to connect analog input signals depends on the analog input ground-reference settings, described in the [Analog Input Ground-Reference Settings](#) section. Also refer to Appendix A, [Device-Specific Information](#), for device I/O connector pinouts.

MUX

Each M Series device has one analog-to-digital converter (ADC). The multiplexers (MUX) route one AI channel at a time to the ADC through the NI-PGIA.

Ground-Reference Settings

The analog input ground-reference settings circuitry selects between differential, referenced single-ended, and non-referenced single-ended input modes. Each AI channel can use a different mode.

Instrumentation Amplifier (NI-PGIA)

The NI programmable gain instrumentation amplifier (NI-PGIA) is a measurement and instrument class amplifier that minimizes settling times for all input ranges. The NI-PGIA can amplify or attenuate an AI signal to ensure that you use the maximum resolution of the ADC.

M Series devices use the NI-PGIA to deliver high accuracy even when sampling multiple channels with small input ranges at fast rates. M Series devices can sample channels in any order at the maximum conversion rate, and you can individually program each channel in a sample with a different input range.

A/D Converter

The analog-to-digital converter (ADC) digitizes the AI signal by converting the analog voltage into a digital number.

AI FIFO

M Series devices can perform both single and multiple A/D conversions of a fixed or infinite number of samples. A large first-in-first-out (FIFO) buffer holds data during AI acquisitions to ensure that no data is lost. M Series devices can handle multiple A/D conversion operations with DMA, interrupts, or programmed I/O.

Analog Input Range

The input range affects the resolution of the M Series device for an AI channel. For example, a 16-bit ADC converts analog inputs into one of 65,536 ($= 2^{16}$) codes—that is, one of 65,536 possible digital values. So, for an input range of -10 V to 10 V , the voltage of each code of a 16-bit ADC is:

$$\frac{(10\text{ V} - (-10\text{ V}))}{2^{16}} = 305\ \mu\text{V}$$

M Series devices use a calibration method that requires some codes (typically about 5% of the codes) to lie outside of the specified range. This

calibration method improves absolute accuracy, but it increases the nominal resolution of input ranges by about 5% over what the formula shown above would indicate.

Choose an input range that matches the expected input range of your signal. A large input range can accommodate a large signal variation, but reduces the voltage resolution. Choosing a smaller input range improves the voltage resolution, but may result in the input signal going out of range.

For more information about setting ranges, refer to the *NI-DAQmx Help* or the *LabVIEW 8.x Help*.

Table 4-1 shows the input ranges and resolutions supported by NI 621x devices.

Table 4-1. Input Ranges for NI 621x

Input Range	Nominal Resolution Assuming 5% Over Range
-10 V to 10 V	320 μ V
-5 V to 5 V	160 μ V
-1 V to 1 V	32 μ V
-200 mV to 200 mV	6.4 μ V

Analog Input Ground-Reference Settings

NI 621x devices support the analog input ground-reference settings shown in Table 4-2.

Table 4-2. Analog Input Ground-Reference Settings

AI Ground-Reference Settings	Description
DIFF	In differential (DIFF) mode, NI 621x devices measure the difference in voltage between two AI signals.
RSE	In referenced single-ended (RSE) mode, NI 621x devices measure the voltage of an AI signal relative to AI GND.
NRSE	In non-referenced single-ended (NRSE) mode, NI 621x devices measure the voltage of an AI signal relative to the AI SENSE input.

The *AI ground-reference* setting determines how you should connect your AI signals to the NI 621x device. Refer to Chapter 5, [Connecting AI Signals on the USB-6210/6211 Devices](#), section for more information.

Ground-reference settings are programmed on a per-channel basis. For example, you might configure the device to scan 12 channels—four differentially-configured channels and eight single-ended channels.

NI 621x devices implement the different analog input ground-reference settings by routing different signals to the NI-PGIA. The NI-PGIA is a differential amplifier. That is, the NI-PGIA amplifies (or attenuates) the difference in voltage between its two inputs. The NI-PGIA drives the ADC with this amplified voltage. The amount of amplification (the gain), is determined by the analog input range, as shown in Figure 4-2.

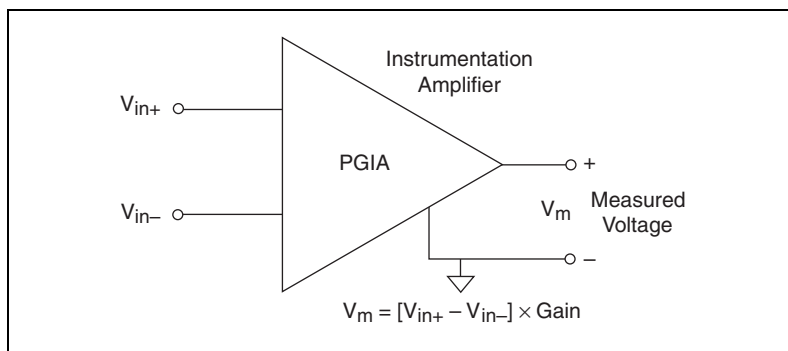

Figure 4-2. NI-PGIA

Table 4-3 shows how signals are routed to the NI-PGIA.

Table 4-3. Signals Routed to the NI-PGIA

AI Ground-Reference Settings	Signals Routed to the Positive Input of the NI-PGIA (V_{in+})	Signals Routed to the Negative Input of the NI-PGIA (V_{in-})
RSE	AI <0..31>	AI GND
NRSE	AI <0..31>	AI SENSE
DIFF	AI <0..7>	AI <8..15>
	AI <16..23>	AI <24..31>

For differential measurements, AI 0 and AI 8 are the positive and negative inputs of differential analog input channel 0. For a complete list of signal

pairs that form differential input channels, refer to the *I/O Connector Signal Descriptions* section of Chapter 3, *Connector Information*.



Caution The maximum input voltages rating of AI signals with respect to AI GND (and for differential signals with respect to each other) are listed in the specifications document for your device. Exceeding the maximum input voltage of AI signals distorts the measurement results. Exceeding the maximum input voltage rating also can damage the device and the computer. NI is *not* liable for any damage resulting from such signal connections.

AI ground-reference setting is sometimes referred to as *AI terminal configuration*.

Configuring AI Ground-Reference Settings in Software

You can program channels on an M Series device to acquire with different ground references.

To enable multimode scanning in LabVIEW, use NI-DAQmx Create Virtual Channel.vi of the NI-DAQmx API. You must use a new VI for each channel or group of channels configured in a different input mode. In Figure 4-3, channel 0 is configured in differential mode, and channel 1 is configured in RSE mode.

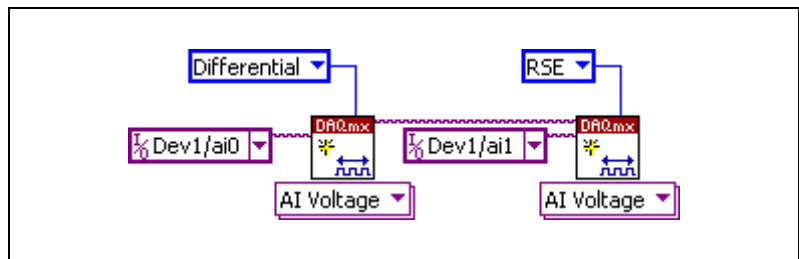

Figure 4-3. Enabling Multimode Scanning in LabVIEW

To configure the input mode of your voltage measurement using the DAQ Assistant, use the **Terminal Configuration** drop-down list. Refer to the *DAQ Assistant Help* for more information about the DAQ Assistant.

To configure the input mode of your voltage measurement using the NI-DAQmx C API, set the **terminalConfig** property. Refer to the *NI-DAQmx C Reference Help* for more information.

Multichannel Scanning Considerations

M Series devices can scan multiple channels at high rates and digitize the signals accurately. However, you should consider several issues when designing your measurement system to ensure the high accuracy of your measurements.

In multichannel scanning applications, accuracy is affected by settling time. When your NI 621x device switches from one AI channel to another AI channel, the device configures the NI-PGIA with the input range of the new channel. The NI-PGIA then amplifies the input signal with the gain for the new input range. Settling time refers to the time it takes the NI-PGIA to amplify the input signal to the desired accuracy before it is sampled by the ADC. The specifications document for your DAQ device lists its settling time.

NI 621x devices are designed to have fast settling times. However, several factors can increase the settling time which decreases the accuracy of your measurements. To ensure fast settling times, you should do the following (in order of importance):

- Use low impedance sources
- Use short high-quality cabling
- Carefully choose the channel scanning order
- Avoid scanning faster than necessary

The following sections contain more information about these factors.

Use Low Impedance Sources

To ensure fast settling times, your signal sources should have an impedance of $<1\text{ k}\Omega$. Large source impedances increase the settling time of the NI-PGIA, and so decrease the accuracy at fast scanning rates.

Settling times increase when scanning high-impedance signals due to a phenomenon called charge injection. Multiplexers contain switches, usually made of switched capacitors. When one of the channels, for example channel 0, is selected in a multiplexer, those capacitors accumulate charge. When the next channel, for example channel 1, is selected, the accumulated charge leaks backward through channel 1. If the output impedance of the source connected to channel 1 is high enough, the resulting reading of channel 1 can be partially affected by the voltage on channel 0. This effect is referred to as ghosting.

If your source impedance is high, you can decrease the scan rate to allow the NI-PGIA more time to settle. Another option is to use a voltage follower circuit external to your DAQ device to decrease the impedance seen by the DAQ device. Refer to the KnowledgeBase document, *How Do I Create a Buffer to Decrease the Source Impedance of My Analog Input Signal?*, by going to ni.com/info and entering the info code `rdbbis`.

Carefully Choose the Channel Scanning Order

Avoid Switching from a Large to a Small Input Range

Switching from a channel with a large input range to a channel with a small input range can greatly increase the settling time.

Suppose a 4 V signal is connected to channel 0 and a 1 mV signal is connected to channel 1. The input range for channel 0 is -10 V to 10 V and the input range of channel 1 is -200 mV to 200 mV .

When the multiplexer switches from channel 0 to channel 1, the input to the NI-PGIA switches from 4 V to 1 mV. The approximately 4 V step from 4 V to 1 mV is 1,000% of the new full-scale range. For a 16-bit device to settle within 0.0015% (15 ppm or 1 LSB) of the $\pm 200\text{ mV}$ full-scale range on channel 1, the input circuitry must settle to within 0.000031% (0.31 ppm or 1/50 LSB) of the $\pm 10\text{ V}$ range. Some devices can take many microseconds for the circuitry to settle this much.

To avoid this effect, you should arrange your channel scanning order so that transitions from large to small input ranges are infrequent.

In general, you do not need this extra settling time when the NI-PGIA is switching from a small input range to a larger input range.

Insert Grounded Channel between Signal Channels

Another technique to improve settling time is to connect an input channel to ground. Then insert this channel in the scan list between two of your signal channels. The input range of the grounded channel should match the input range of the signal after the grounded channel in the scan list.

Consider again the example above where a 4 V signal is connected to channel 0 and a 1 mV signal is connected to channel 1. Suppose the input range for channel 0 is -10 V to 10 V and the input range of channel 1 is -200 mV to 200 mV .

You can connect channel 2 to AI GND (or you can use the internal ground signal; refer to *Internal Channels* in the *NI-DAQmx Help*). Set the input range of channel 2 to -200 mV to 200 mV to match channel 1. Then scan channels in the order: 0, 2, 1.

Inserting a grounded channel between signal channels improves settling time because the NI-PGIA adjusts to the new input range setting faster when the input is grounded.

Minimize Voltage Step between Adjacent Channels

When scanning between channels that have the same input range, the settling time increases with the voltage step between the channels. If you know the expected input range of your signals, you can group signals with similar expected ranges together in your scan list.

For example, suppose all channels in a system use a -5 to 5 V input range. The signals on channels 0, 2, and 4 vary between 4.3 V and 5 V. The signals on channels 1, 3, and 5 vary between -4 V and 0 V. Scanning channels in the order 0, 2, 4, 1, 3, 5 produces more accurate results than scanning channels in the order 0, 1, 2, 3, 4, 5.

Avoid Scanning Faster Than Necessary

Designing your system to scan at slower speeds gives the NI-PGIA more time to settle to a more accurate level. Here are two examples to consider.

Example 1

Averaging many AI samples can increase the accuracy of the reading by decreasing noise effects. In general, the more points you average, the more accurate the final result. However, you may choose to decrease the number of points you average and slow down the scanning rate.

Suppose you want to sample 10 channels over a period of 20 ms and average the results. You could acquire 250 points from each channel at a scan rate of 125 kS/s. Another method would be to acquire 500 points from each channel at a scan rate of 250 kS/s. Both methods take the same amount of time. Doubling the number of samples averaged (from 250 to 500) decreases the effect of noise by a factor of 1.4 (the square root of 2). However, doubling the number of samples (in this example) decreases the time the NI-PGIA has to settle from 8 μ s to 4 μ s. In some cases, the slower scan rate system returns more accurate results.

Example 2

If the time relationship between channels is not critical, you can sample from the same channel multiple times and scan less frequently. For example, suppose an application requires averaging 100 points from channel 0 and averaging 100 points from channel 1. You could alternate reading between channels—that is, read one point from channel 0, then one point from channel 1, and so on. You also could read all 100 points from channel 0 then read 100 points from channel 1. The second method switches between channels much less often and is affected much less by settling time.

Analog Input Data Acquisition Methods

When performing analog input measurements, you either can perform software-timed or hardware-timed acquisitions. Hardware-timed acquisitions can be buffered or non-buffered.

Software-Timed Acquisitions

With a software-timed acquisition, software controls the rate of the acquisition. Software sends a separate command to the hardware to initiate each ADC conversion. In NI-DAQmx, software-timed acquisitions are referred to as having on-demand timing. Software-timed acquisitions are also referred to as immediate or static acquisitions and are typically used for reading a single sample of data.

Hardware-Timed Acquisitions

With hardware-timed acquisitions, a digital hardware signal (ai/SampleClock) controls the rate of the acquisition. This signal can be generated internally on your device or provided externally.

Hardware-timed acquisitions have several advantages over software-timed acquisitions.

- The time between samples can be much shorter.
- The timing between samples is deterministic.
- Hardware-timed acquisitions can use hardware triggering.

Hardware-timed operations can be buffered or non-buffered.

Buffered

In a buffered acquisition, data is moved from the DAQ device's onboard FIFO memory to a PC buffer using USB signal streams or programmed I/O before it is transferred to application memory. Buffered acquisitions typically allow for much faster transfer rates than non-buffered acquisitions because data is moved in large blocks, rather than one point at a time.

One property of buffered I/O operations is the sample mode. The sample mode can be either finite or continuous.

Finite sample mode acquisition refers to the acquisition of a specific, predetermined number of data samples. Once the specified number of samples has been written out, the generation stops. If you use a reference trigger, you must use finite sample mode.

Continuous acquisition refers to the acquisition of an unspecified number of samples. Instead of acquiring a set number of data samples and stopping, a continuous acquisition continues until you stop the operation. Continuous acquisition is also referred to as *double-buffered* or *circular-buffered acquisition*.

If data cannot be transferred across the bus fast enough, the FIFO becomes full. New acquisitions will overwrite data in the FIFO before it can be transferred to host memory. The device generates an error in this case. With continuous operations, if the user program does not read data out of the PC buffer fast enough to keep up with the data transfer, the buffer could reach an overflow condition, causing an error to be generated.

Non-Buffered

Hardware-timed, non-buffered mode is not supported for USB M series devices.

Analog Input Digital Triggering

Analog input supports three different triggering actions:

- Start trigger
- Reference trigger
- Pause trigger

Refer to the *AI Start Trigger Signal*, *AI Reference Trigger Signal*, and *AI Pause Trigger Signal* sections for information about these triggers.

A digital trigger can initiate these actions. All NI 621x devices support digital triggering. NI 621x devices do not support analog triggering.

Field Wiring Considerations

Environmental noise can seriously affect the measurement accuracy of the device if you do not take proper care when running signal wires between signal sources and the device. The following recommendations apply mainly to AI signal routing to the device, although they also apply to signal routing in general.

Minimize noise pickup and maximize measurement accuracy by taking the following precautions.

- Use DIFF AI connections to reject common-mode noise.
- Use individually shielded, twisted-pair wires to connect AI signals to the device. With this type of wire, the signals attached to the positive and negative input channels are twisted together and then covered with a shield. You then connect this shield only at one point to the signal source ground. This kind of connection is required for signals traveling through areas with large magnetic fields or high electromagnetic interference.

Refer to the NI Developer Zone document, *Field Wiring and Noise Considerations for Analog Signals*, for more information. To access this document, go to ni.com/info and enter the info code `rdfwn3`.

Analog Input Timing Signals

In order to provide all of the timing functionality described throughout this section, M Series devices have a flexible timing engine. Figure 4-4 summarizes all of the timing options provided by the analog input timing engine.

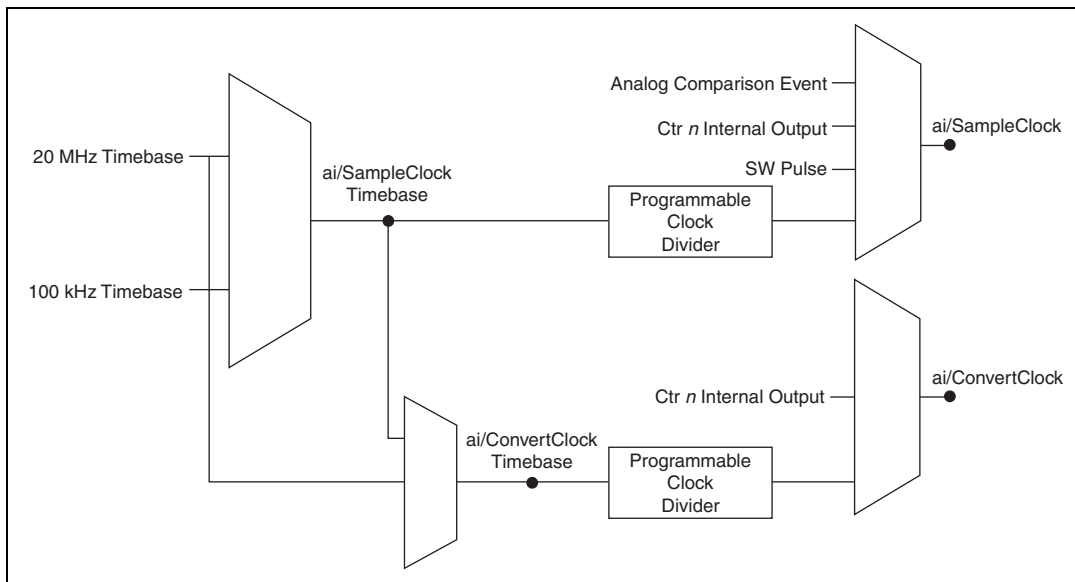

Figure 4-4. Analog Input Timing Options

M Series devices use ai/SampleClock and ai/ConvertClock to perform interval sampling. As Figure 4-5 shows, ai/SampleClock controls the sample period, which is determined by the following equation:

$$1/\text{Sample Period} = \text{Sample Rate}$$

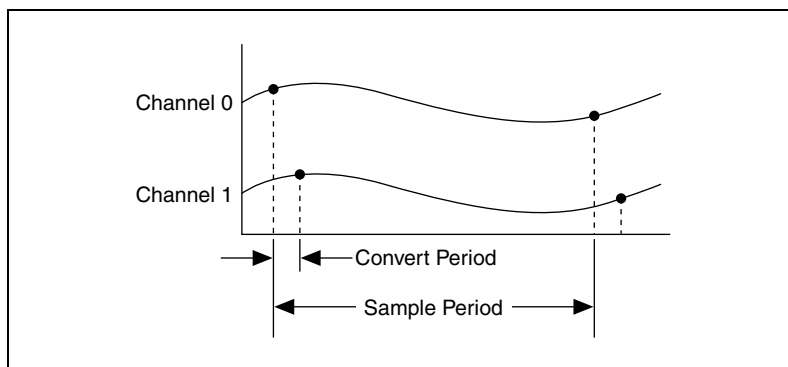

Figure 4-5. Interval Sampling

ai/ConvertClock controls the Convert Period, which is determined by the following equation:

$$1/\text{Convert Period} = \text{Convert Rate}$$

NI-DAQmx chooses the default convert rate to allow for the maximum settling time between conversions. Typically, this rate is the sampling rate for the task multiplied by the number of channels in the task.



Note The sampling rate is the fastest you can acquire data on the device and still achieve accurate results. For example, if an M Series device has a sampling rate of 250 kS/s, this sampling rate is aggregate—one channel at 250 kS/s or two channels at 125 kS/s per channel illustrates the relationship.

Posttriggered data acquisition allows you to view only data that is acquired after a trigger event is received. A typical posttriggered DAQ sequence is shown in Figure 4-6. The sample counter is loaded with the specified number of posttrigger samples, in this example, five. The value decrements with each pulse on ai/SampleClock, until the value reaches zero and all desired samples have been acquired.

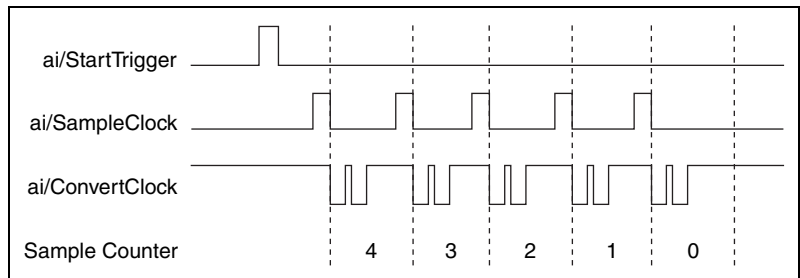

Figure 4-6. Posttriggered Data Acquisition Example

Pretriggered data acquisition allows you to view data that is acquired before the trigger of interest, in addition to data acquired after the trigger. Figure 4-7 shows a typical pretriggered DAQ sequence. ai/StartTrigger can be either a hardware or software signal. If ai/StartTrigger is set up to be a software start trigger, an output pulse appears on the ai/StartTrigger line when the acquisition begins. When the ai/StartTrigger pulse occurs, the sample counter is loaded with the number of pretriggered samples, in this example, four. The value decrements with each pulse on ai/SampleClock, until the value reaches zero. The sample counter is then loaded with the number of posttriggered samples, in this example, three.

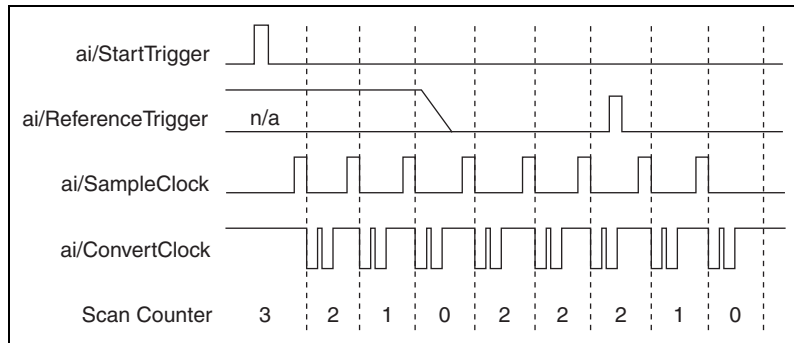

Figure 4-7. Pretriggered Data Acquisition Example

If an ai/ReferenceTrigger pulse occurs before the specified number of pretrigger samples are acquired, the trigger pulse is ignored. Otherwise, when the ai/ReferenceTrigger pulse occurs, the sample counter value decrements until the specified number of posttrigger samples have been acquired.

USB M Series devices feature the following analog input timing signals.

- AI Sample Clock Signal
- AI Sample Clock Timebase Signal
- AI Convert Clock Signal
- AI Convert Clock Timebase Signal
- AI Hold Complete Event Signal
- AI Start Trigger Signal
- AI Reference Trigger Signal
- AI Pause Trigger Signal

AI Sample Clock Signal

Use the AI Sample Clock (ai/SampleClock) signal to initiate a set of measurements. Your M Series device samples the AI signals of every channel in the task once for every ai/SampleClock. A measurement acquisition consists of one or more samples.

You can specify an internal or external source for ai/SampleClock. You also can specify whether the measurement sample begins on the rising edge or falling edge of ai/SampleClock.

Using an Internal Source

One of the following internal signals can drive ai/SampleClock.

- Counter n Internal Output
- AI Sample Clock Timebase (divided down)
- A software pulse

A programmable internal counter divides down the sample clock timebase.

Using an External Source

Use the external signals PFI <0..3> or PFI <8..11> as the source of ai/SampleClock.

Routing AI Sample Clock Signal to an Output Terminal

You can route ai/SampleClock out to any PFI <4..7> or PFI <12..15> terminal. This pulse is always active high.

You can specify the output to have one of two behaviors. With the pulse behavior, your DAQ device briefly pulses the PFI terminal once for every occurrence of ai/SampleClock.

With level behavior, your DAQ device drives the PFI terminal high during the entire sample.

Other Timing Requirements

Your DAQ device only acquires data during an acquisition. The device ignores ai/SampleClock when a measurement acquisition is not in progress. During a measurement acquisition, you can cause your DAQ device to ignore ai/SampleClock using the ai/PauseTrigger signal.

A counter on your device internally generates ai/SampleClock unless you select some external source. ai/StartTrigger starts this counter and either software or hardware can stop it once a finite acquisition completes. When using an internally generated ai/SampleClock, you also can specify a configurable delay from ai/StartTrigger to the first ai/SampleClock pulse. By default, this delay is set to two ticks of the ai/SampleClockTimebase signal. When using an externally generated ai/SampleClock, you must ensure the clock signal is consistent with respect to the timing requirements of ai/ConvertClock. Failure to do so may result in ai/SampleClock pulses that are masked off and acquisitions with erratic sampling intervals. Refer

to AI Convert Clock Signal for more information about the timing requirements between ai/ConvertClock and ai/SampleClock.

Figure 4-8 shows the relationship of ai/SampleClock to ai/StartTrigger.

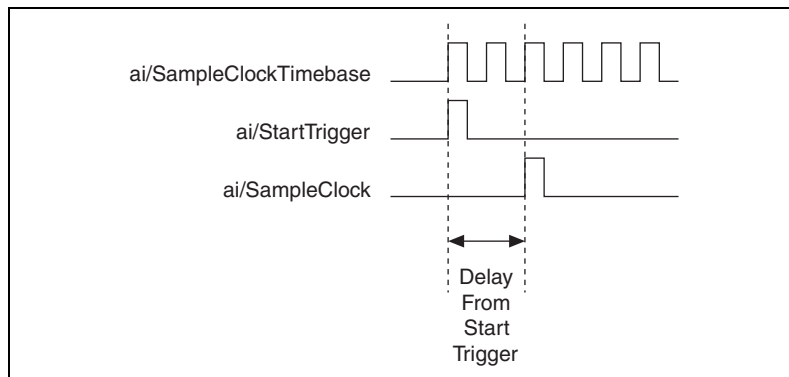

Figure 4-8. ai/SampleClock and ai/StartTrigger

AI Sample Clock Timebase Signal

You can route any of the following signals to be the AI Sample Clock Timebase (ai/SampleClockTimebase) signal:

- 20 MHz Timebase
- 100 kHz Timebase
- PFI <0..3>, PFI <8..11>

ai/SampleClockTimebase is not available as an output on the I/O connector. ai/SampleClockTimebase is divided down to provide one of the possible sources for ai/SampleClock. You can configure the polarity selection for ai/SampleClockTimebase as either rising or falling edge.

AI Convert Clock Signal

Use the AI Convert Clock (ai/ConvertClock) signal to initiate a single A/D conversion on a single channel. A sample (controlled by the AI Sample Clock) consists of one or more conversions.

You can specify either an internal or external signal as the source of ai/ConvertClock. You also can specify whether the measurement sample begins on the rising edge or falling edge of ai/ConvertClock.

By default, NI-DAQmx chooses the fastest conversion rate possible based on the speed of the A/D converter and adds 10 μ s of padding between each

channel to allow for adequate settling time. This scheme enables the channels to approximate simultaneous sampling and still allow for adequate settling time. If the AI Sample Clock rate is too fast to allow for this 10 μ s of padding, NI-DAQmx chooses the conversion rate so that the AI Convert Clock pulses are evenly spaced throughout the sample.

To explicitly specify the conversion rate, use **AI Convert Clock Rate DAQmx Timing** property node or function.



Caution Setting the conversion rate higher than the maximum rate specified for your device will result in errors.

Using an Internal Source

One of the following internal signals can drive ai/ConvertClock:

- AI Convert Clock Timebase (divided down)
- Counter n Internal Output

A programmable internal counter divides down the AI Convert Clock Timebase to generate ai/ConvertClock. The counter is started by ai/SampleClock and continues to count down to zero, produces an ai/ConvertClock, reloads itself, and repeats the process until the sample is finished. It then reloads itself in preparation for the next ai/SampleClock pulse.

Using an External Source

Use the external signals PFI <0..3> or PFI <8..11> as the source of ai/ConvertClock:

Routing AI Convert Clock Signal to an Output Terminal

You can route ai/ConvertClock (as an active low signal) out to any PFI <4..7> or PFI <12..15> terminal.

Using a Delay from Sample Clock to Convert Clock

When using an internally generated ai/ConvertClock, you also can specify a configurable delay from ai/SampleClock to the first ai/ConvertClock pulse within the sample. By default, this delay is three ticks of ai/ConvertClockTimebase.

Figure 4-9 shows the relationship of ai/SampleClock to ai/ConvertClock.

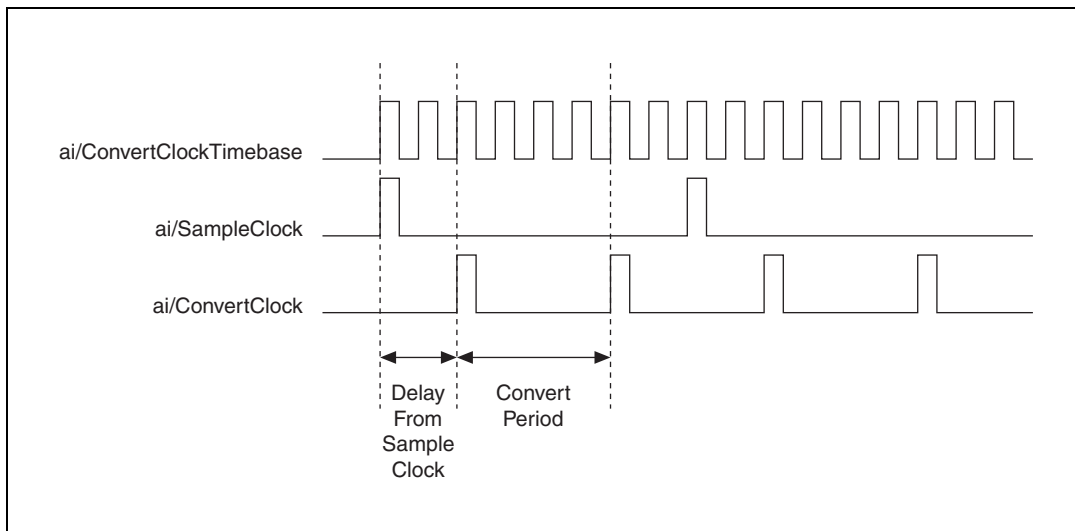

Figure 4-9. ai/SampleClock and ai/ConvertClock

Other Timing Requirements

The sample and conversion level timing of M Series devices work such that clock signals are gated off unless the proper timing requirements are met. For example, the device ignores both ai/SampleClock and ai/ConvertClock until it receives a valid ai/StartTrigger signal. Once the device recognizes an ai/SampleClock pulse, it ignores subsequent ai/SampleClock pulses until it receives the correct number of ai/ConvertClock pulses.

Similarly, the device ignores all ai/ConvertClock pulses until it recognizes an ai/SampleClock pulse. Once the device receives the correct number of ai/ConvertClock pulses, it ignores subsequent ai/ConvertClock pulses until it receives another ai/SampleClock. Figures 4-10, 4-11, 4-12, and 4-13 show timing sequences for a four-channel acquisition (using AI channels 0, 1, 2, and 3) and demonstrate proper and improper sequencing of ai/SampleClock and ai/ConvertClock.

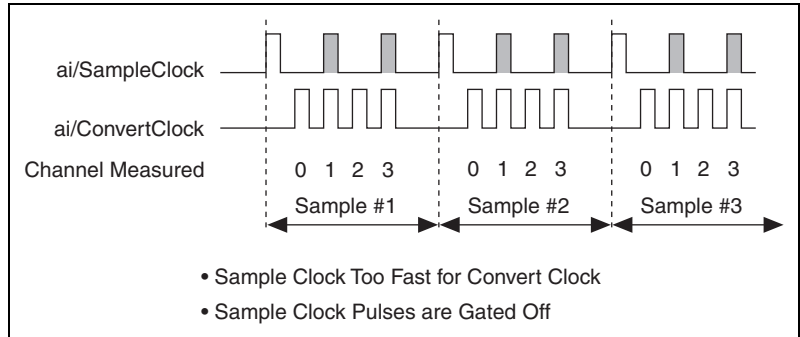

Figure 4-10. ai/SampleClock Too Fast

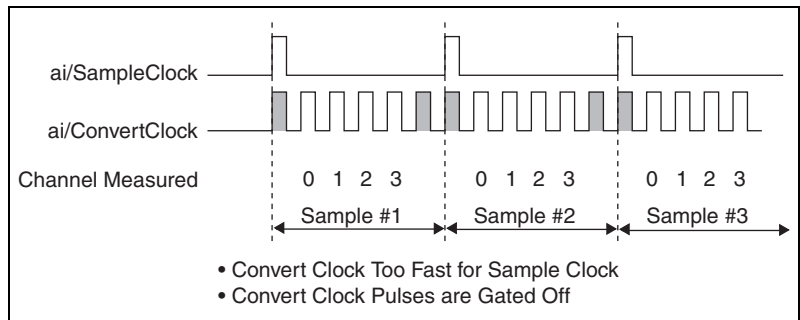

Figure 4-11. ai/ConvertClock Too Fast

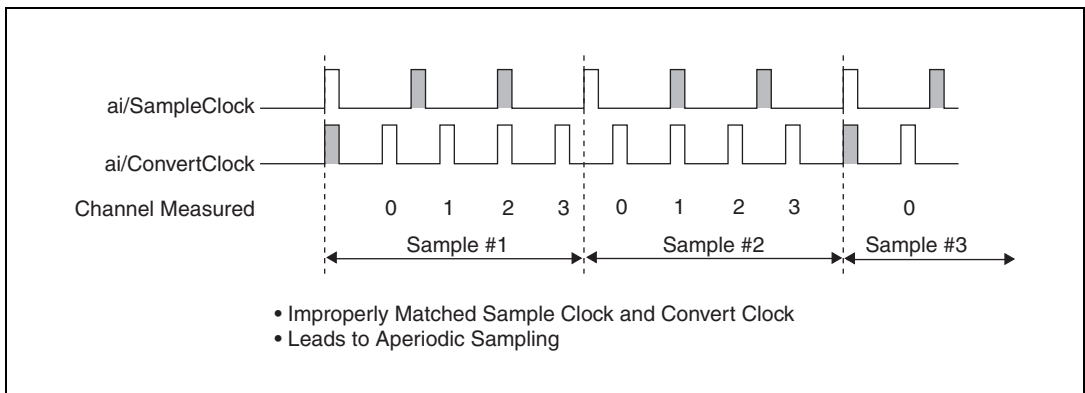

Figure 4-12. ai/SampleClock and ai/ConvertClock Improperly Matched

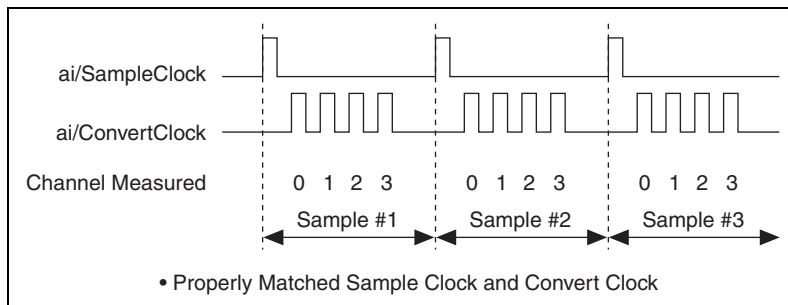

Figure 4-13. ai/SampleClock and ai/ConvertClock Properly Matched

It is also possible to use a single external signal to drive both ai/SampleClock and ai/ConvertClock at the same time. In this mode, each tick of the external clock will cause a conversion on the ADC. Figure 4-14 shows this timing relationship.

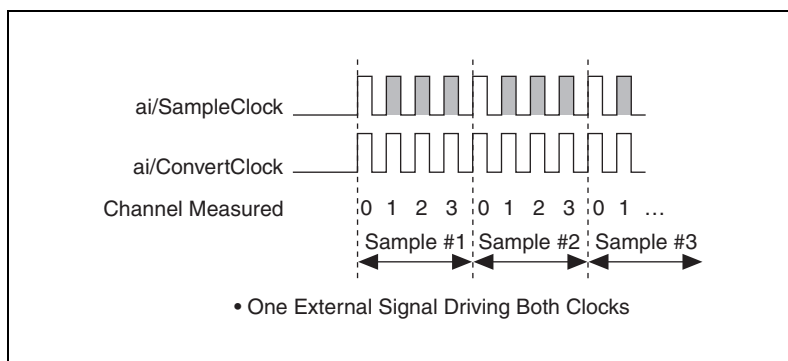

Figure 4-14. Single External Signal Driving ai/SampleClock and ai/ConvertClock Simultaneously

AI Convert Clock Timebase Signal

The AI Convert Clock Timebase (ai/ConvertClockTimebase) signal is divided down to provide one of the possible sources for ai/ConvertClock. Use one of the following signals as the source of ai/ConvertClockTimebase:

- ai/SampleClockTimebase
- 20 MHz Timebase

ai/ConvertClockTimebase is not available as an output on the I/O connector.

AI Hold Complete Event Signal

The AI Hold Complete Event (ai/HoldCompleteEvent) signal generates a pulse after each A/D conversion begins. You can route ai/HoldCompleteEvent out to any PFI <4..8> or PFI <12..15> terminal.

The polarity of ai/HoldCompleteEvent is software-selectable, but is typically configured so that a low-to-high leading edge can clock external AI multiplexers indicating when the input signal has been sampled and can be removed.

AI Start Trigger Signal

Use the AI Start Trigger (ai/StartTrigger) signal to begin a measurement acquisition. A measurement acquisition consists of one or more samples. If you do not use triggers, begin a measurement with a software command. Once the acquisition begins, configure the acquisition to stop:

- When a certain number of points are sampled (in finite mode)
- After a hardware reference trigger (in finite mode)
- With a software command (in continuous mode)

An acquisition that uses a start trigger (but not a reference trigger) is sometimes referred to as a posttriggered acquisition.

Using a Digital Source

To use ai/StartTrigger with a digital source, specify a source and an edge. The source can be any of the following signals:

- PFI <0..3>, PFI <8..11>
- Counter *n* Internal Output

The source also can be one of several other internal signals on your DAQ device. Refer to *Device Routing in MAX* in the *NI-DAQmx Help* or the *LabVIEW 8.x Help* for more information.

You also can specify whether the measurement acquisition begins on the rising edge or falling edge of ai/StartTrigger.

Routing AI Start Trigger to an Output Terminal

You can route ai/StartTrigger out to any PFI <4..8> or PFII <12..15> terminal.

The output is an active high pulse.

The device also uses ai/StartTrigger to initiate pretriggered DAQ operations. In most pretriggered applications, a software trigger generates ai/StartTrigger. Refer to the *AI Reference Trigger Signal* section for a complete description of the use of ai/StartTrigger and ai/ReferenceTrigger in a pretriggered DAQ operation.

AI Reference Trigger Signal

Use a reference trigger (ai/ReferenceTrigger) signal to stop a measurement acquisition. To use a reference trigger, specify a buffer of finite size and a number of pretrigger samples (samples that occur before the reference trigger). The number of posttrigger samples (samples that occur after the reference trigger) desired is the buffer size minus the number of pretrigger samples.

Once the acquisition begins, the DAQ device writes samples to the buffer. After the DAQ device captures the specified number of pretrigger samples, the DAQ device begins to look for the reference trigger condition. If the reference trigger condition occurs before the DAQ device captures the specified number of pretrigger samples, the DAQ device ignores the condition.

If the buffer becomes full, the DAQ device continuously discards the oldest samples in the buffer to make space for the next sample. This data can be accessed (with some limitations) before the DAQ device discards it. Refer to the KnowledgeBase document, *Can a Pretriggered Acquisition be Continuous?*, for more information. To access this KnowledgeBase, go to ni.com/info and enter the info code `rdcanq`.

When the reference trigger occurs, the DAQ device continues to write samples to the buffer until the buffer contains the number of posttrigger samples desired. Figure 4-15 shows the final buffer.

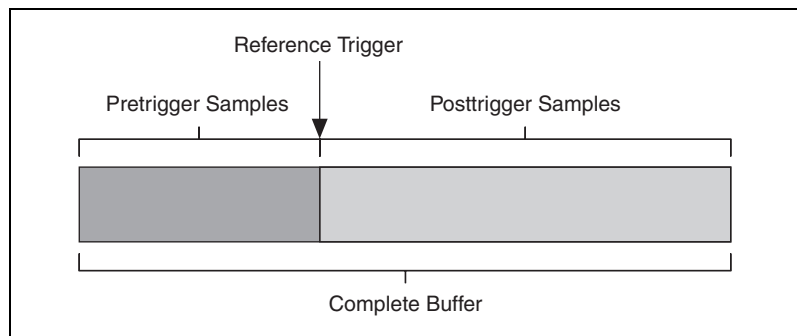

Figure 4-15. Reference Trigger Final Buffer

Using a Digital Source

To use ai/ReferenceTrigger with a digital source, specify a source and an edge. The source can be the PFI <0..3> or PFI <8..11> signals.

The source also can be one of several internal signals on your DAQ device. Refer to *Device Routing in MAX* in the *NI-DAQmx Help* or the *LabVIEW 8.x Help* for more information.

You also can specify whether the measurement acquisition stops on the rising edge or falling edge of ai/ReferenceTrigger.

Routing AI Reference Trigger Signal to an Output Terminal

You can route ai/ReferenceTrigger out to any PFI <4..7> or PFI <12..15> terminal.

AI Pause Trigger Signal

You can use the AI Pause Trigger (ai/PauseTrigger) signal to pause and resume a measurement acquisition. The internal sample clock pauses while the external trigger signal is active and resumes when the signal is inactive. You can program the active level of the pause trigger to be high or low.

Using a Digital Source

To use ai/SampleClock, specify a source and a polarity. The source can be the PFI <0..3> or PFI <8..11> signals.

The source also can be one of several other internal signals on your DAQ device. Refer to *Device Routing in MAX* in the *NI-DAQmx Help* or the *LabVIEW 8.x Help* for more information.

Getting Started with AI Applications in Software

You can use the M Series device in the following analog input applications.

- Single-point analog input
- Finite analog input
- Continuous analog input

You can perform these applications through DMA, interrupt, or programmed I/O data transfer mechanisms. Some of the applications also use start, reference, and pause triggers.



Note For more information about programming analog input applications and triggers in software, refer to the *NI-DAQmx Help* or the *LabVIEW 8.x Help*.

Connecting AI Signals on the USB-6210/6211 Devices

Table 5-1 summarizes the recommended input configuration for both types of signal sources on NI 6210/6211 devices.

Table 5-1. Analog Input Configuration

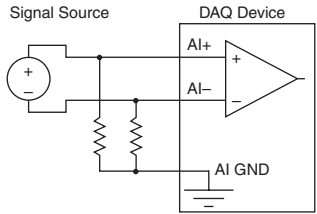
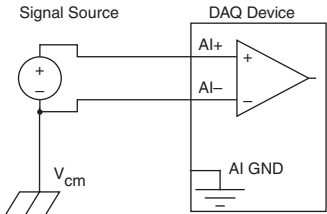
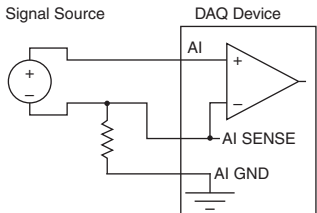
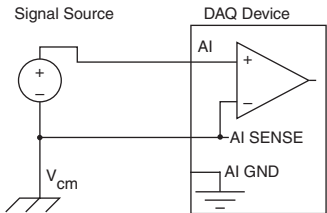
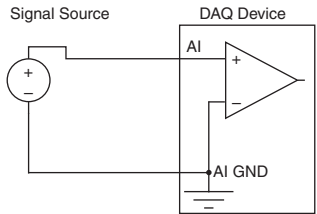
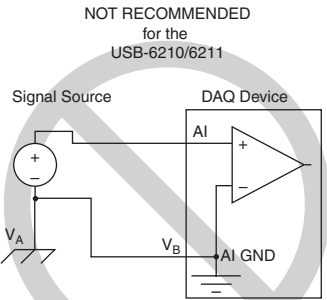
AI Ground-Reference Setting*	Floating Signal Sources (Not Connected to Building Ground)	Ground-Referenced Signal Sources**
	Examples: <ul style="list-style-type: none"> • Ungrounded thermocouples • Signal conditioning with isolated outputs • Battery devices 	Example: <ul style="list-style-type: none"> • Plug-in instruments with non-isolated outputs
Differential		
Single-Ended—Non-Referenced (NRSE)		
Single-Ended—Referenced (RSE)		<p style="text-align: center;">NOT RECOMMENDED for the USB-6210/6211</p>  <p style="text-align: center;">Ground-loop potential ($V_A - V_B$) are added to measured signal.</p>
<p>* Refer to the Analog Input Ground-Reference Settings section of Chapter 4, Analog Input, for descriptions of the RSE, NRSE, and DIFF modes and software considerations.</p> <p>** Refer to the Connecting Ground-Referenced Signal Sources section for more information.</p>		

Connecting Floating Signal Sources

What Are Floating Signal Sources?

A *floating signal source* is not connected to the building ground system, but has an isolated ground-reference point. Some examples of floating signal sources are outputs of transformers, thermocouples, battery-powered devices, optical isolators, and isolation amplifiers. An instrument or device that has an isolated output is a floating signal source.

When to Use Differential Connections with Floating Signal Sources

Use DIFF input connections for any channel that meets any of the following conditions:

- The input signal is low level (less than 1 V).
- The leads connecting the signal to the device are greater than 3 m (10 ft).
- The input signal requires a separate ground-reference point or return signal.
- The signal leads travel through noisy environments.
- Two analog input channels, AI+ and AI-, are available for the signal.

DIFF signal connections reduce noise pickup and increase common-mode noise rejection. DIFF signal connections also allow input signals to float within the common-mode limits of the NI-PGIA.

Refer to the [Using Differential Connections for Floating Signal Sources](#) section for more information about differential connections.

When to Use Referenced Single-Ended (RSE) Connections with Floating Signal Sources

Only use RSE input connections if the input signal meets the following conditions.

- The input signal can share a common reference point, AI GND, with other signals that use RSE.
- The input signal is high-level (greater than 1 V).
- The leads connecting the signal to the device are less than 3 m (10 ft).

DIFF input connections are recommended for greater signal integrity for any input signal that does not meet the preceding conditions.

In the single-ended modes, more electrostatic and magnetic noise couples into the signal connections than in DIFF configurations. The coupling is the result of differences in the signal path. Magnetic coupling is proportional to the area between the two signal conductors. Electrical coupling is a function of how much the electric field differs between the two conductors.

With this type of connection, the NI-PGIA rejects both the common-mode noise in the signal and the ground potential difference between the signal source and the device ground.

Refer to the [Using Referenced Single-Ended \(RSE\) Connections for Floating Signal Sources](#) section for more information about RSE connections.

When to Use Non-Referenced Single-Ended (NRSE) Connections with Floating Signal Sources

Only use NRSE input connections if the input signal meets the following conditions.

- The input signal is high-level (greater than 1 V).
- The leads connecting the signal to the device are less than 3 m (10 ft).

DIFF input connections are recommended for greater signal integrity for any input signal that does not meet the preceding conditions.

In the single-ended modes, more electrostatic and magnetic noise couples into the signal connections than in DIFF configurations. The coupling is the result of differences in the signal path. Magnetic coupling is proportional to the area between the two signal conductors. Electrical coupling is a function of how much the electric field differs between the two conductors.

With this type of connection, the NI-PGIA rejects both the common-mode noise in the signal and the ground potential difference between the signal source and the device ground.

Refer to the [Using Non-Referenced Single-Ended \(NRSE\) Connections for Floating Signal Sources](#) section for more information about NRSE connections.

Using Differential Connections for Floating Signal Sources

It is important to connect the negative lead of a floating source to AI GND (either directly or through a bias resistor). Otherwise, the source may float out of the maximum working voltage range of the NI-PGIA and the DAQ device returns erroneous data.

The easiest way to reference the source to AI GND is to connect the positive side of the signal to AI+ and connect the negative side of the signal to AI GND as well as to AI- without using resistors. This connection works well for DC-coupled sources with low source impedance (less than 100 Ω).

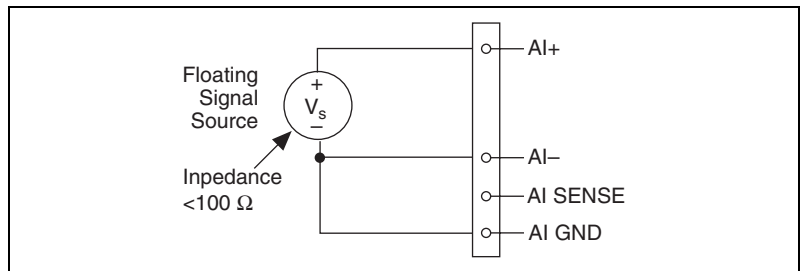

Figure 5-1. Differential Connections for Floating Signal Sources without Bias Resistors

However, for larger source impedances, this connection leaves the DIFF signal path significantly off balance. Noise that couples electrostatically onto the positive line does not couple onto the negative line because it is connected to ground. This noise appears as a DIFF-mode signal instead of a common-mode signal, and thus appears in your data. In this case, instead of directly connecting the negative line to AI GND, connect the negative line to AI GND through a resistor that is about 100 times the equivalent source impedance. The resistor puts the signal path nearly in balance, so that about the same amount of noise couples onto both connections, yielding better rejection of electrostatically coupled noise. This configuration does not load down the source (other than the very high input impedance of the NI-PGIA).

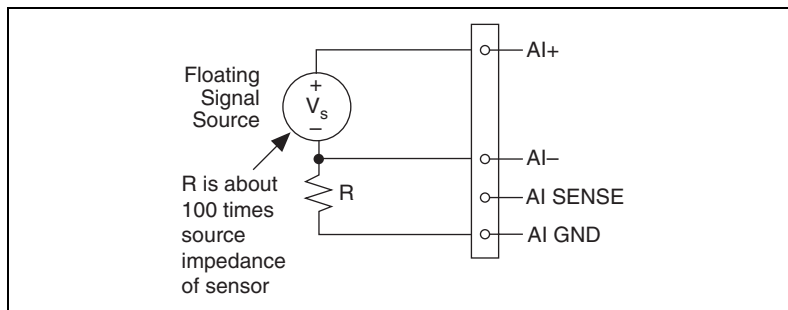

Figure 5-2. Differential Connections for Floating Signal Sources with Single Bias Resistor

You can fully balance the signal path by connecting another resistor of the same value between the positive input and AI GND on the USB-621x device, as shown in Figure 5-3. This fully balanced configuration offers slightly better noise rejection, but has the disadvantage of loading the source down with the series combination (sum) of the two resistors. If, for example, the source impedance is $2\text{ k}\Omega$ and each of the two resistors is $100\text{ k}\Omega$, the resistors load down the source with $200\text{ k}\Omega$ and produce a -1% gain error.

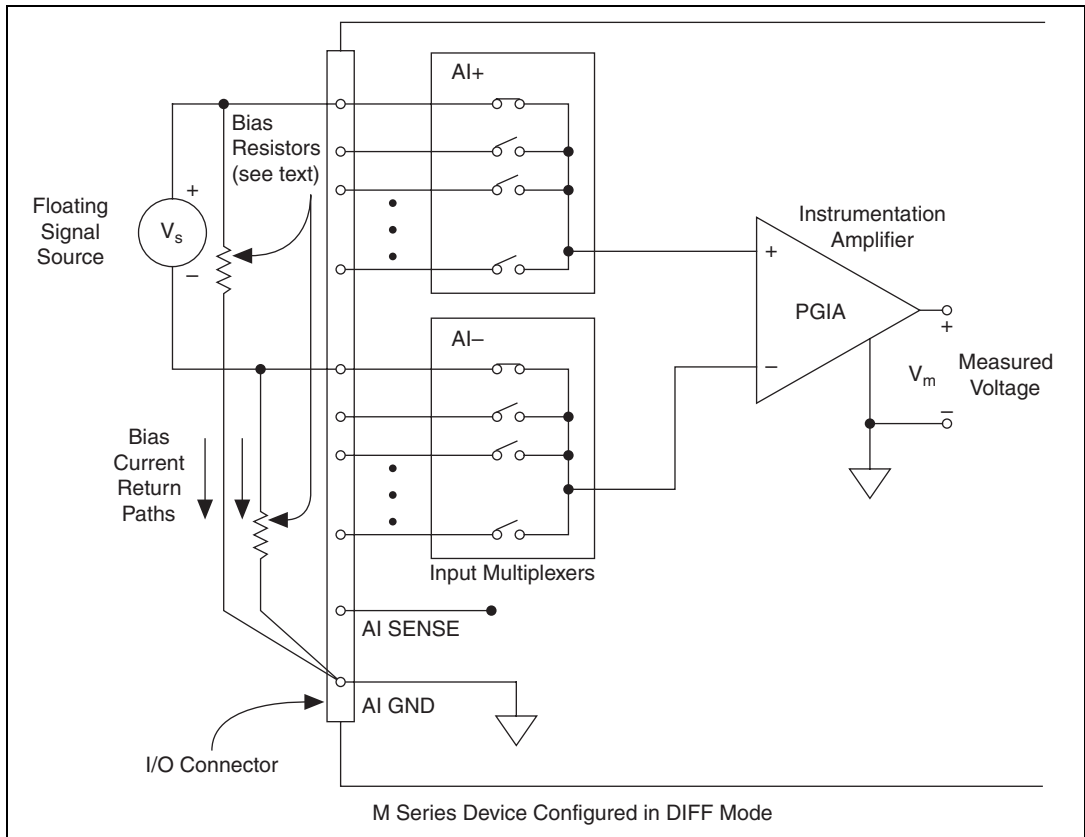

Figure 5-3. Differential Connections for Floating Signal Sources with Balanced Bias Resistors

Both inputs of the NI-PGIA require a DC path to ground in order for the NI-PGIA to work. If the source is AC coupled (capacitively coupled), the NI-PGIA needs a resistor between the positive input and AI GND. If the source has low-impedance, choose a resistor that is large enough not to significantly load the source but small enough not to produce significant input offset voltage as a result of input bias current (typically 100 k Ω to 1 M Ω). In this case, connect the negative input directly to AI GND. If the source has high output impedance, balance the signal path as previously described using the same value resistor on both the positive and negative

inputs; be aware that there is some gain error from loading down the source, as shown in Figure 5-4.

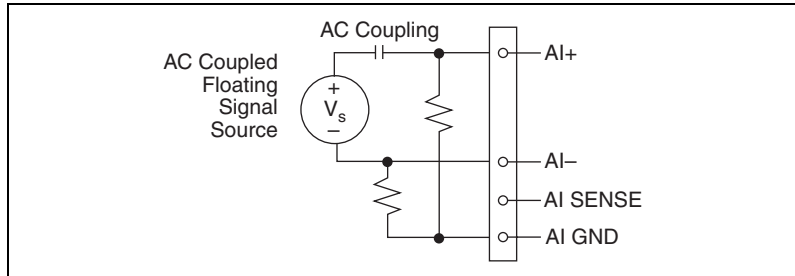

Figure 5-4. Differential Connections for AC Coupled Floating Sources with Balanced Bias Resistors

Using Non-Referenced Single-Ended (NRSE) Connections for Floating Signal Sources

It is important to connect the negative lead of a floating signals source to AI GND (either directly or through a resistor). Otherwise the source may float out of the valid input range of the NI-PGIA and the DAQ device returns erroneous data.

Figure 5-5 shows a floating source connected to the DAQ device in NRSE mode.

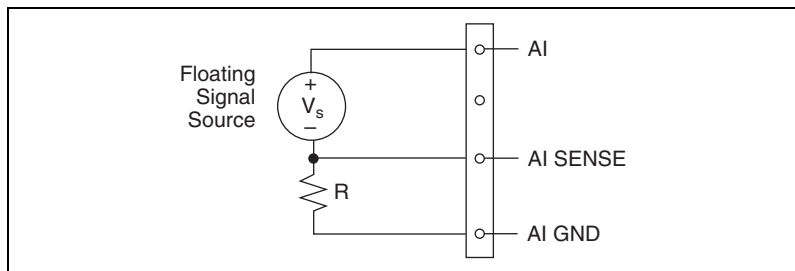

Figure 5-5. NRSE Connections for Floating Signal Sources

All of the bias resistor configurations discussed in the [Using Differential Connections for Floating Signal Sources](#) section apply to the NRSE bias resistors as well. Replace AI– with AI SENSE in Figures 5-1, 5-2, 5-3, and 5-4 for configurations with zero to two bias resistors. The noise rejection of NRSE mode is better than RSE mode because the AI SENSE connection is made remotely near the source. However, the noise rejection of NRSE mode is worse than DIFF mode because the AI SENSE

connection is shared with all channels rather than being cabled in a twisted pair with the AI+ signal.

Using the DAQ Assistant, you can configure the channels for RSE or NRSE input modes. Refer to the [Configuring AI Ground-Reference Settings in Software](#) section of Chapter 4, *Analog Input*, for more information about the DAQ Assistant.

Using Referenced Single-Ended (RSE) Connections for Floating Signal Sources

Figure 5-6 shows how to connect a floating signal source to the NI 621x device configured for RSE mode.

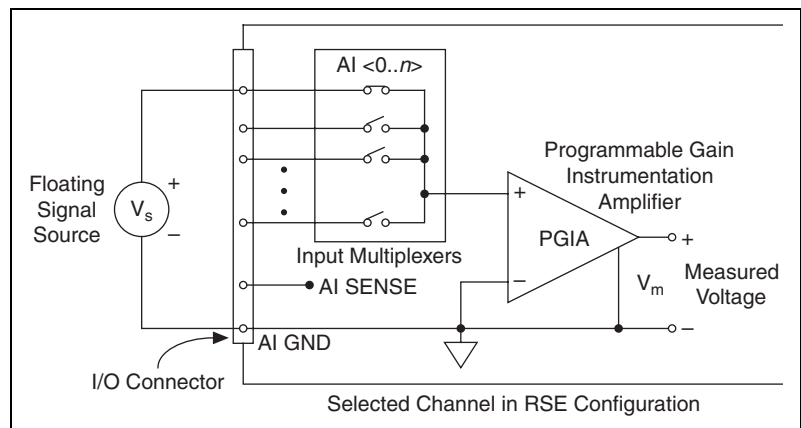

Figure 5-6. RSE Connections for Floating Signal Sources

Using the DAQ Assistant, you can configure the channels for RSE or NRSE input modes. Refer to the [Configuring AI Ground-Reference Settings in Software](#) section of Chapter 4, *Analog Input*, for more information about the DAQ Assistant.

Connecting Ground-Referenced Signal Sources

What Are Ground-Referenced Signal Sources?

A *ground-referenced signal source* is a signal source connected to the building system ground. It is already connected to a common ground point with respect to the device, assuming that the computer is plugged into the same power system as the source. Non-isolated outputs of instruments and devices that plug into the building power system fall into this category.

The difference in ground potential between two instruments connected to the same building power system is typically between 1 and 100 mV, but the difference can be much higher if power distribution circuits are improperly connected. If a grounded signal source is incorrectly measured, this difference can appear as measurement error. Follow the connection instructions for grounded signal sources to eliminate this ground potential difference from the measured signal.

When to Use Differential Connections with Ground-Referenced Signal Sources

Use DIFF input connections for any channel that meets any of the following conditions:

- The input signal is low level (less than 1 V).
- The leads connecting the signal to the device are greater than 3 m (10 ft).
- The input signal requires a separate ground-reference point or return signal.
- The signal leads travel through noisy environments.
- Two analog input channels, AI+ and AI–, are available.

DIFF signal connections reduce noise pickup and increase common-mode noise rejection. DIFF signal connections also allow input signals to float within the common-mode limits of the NI-PGIA.

Refer to the [Using Differential Connections for Ground-Referenced Signal Sources](#) section for more information about differential connections.

When to Use Non-Referenced Single-Ended (NRSE) Connections with Ground-Referenced Signal Sources

Only use non-referenced single-ended input connections if the input signal meets the following conditions.

- The input signal is high-level (greater than 1 V).
- The leads connecting the signal to the device are less than 3 m (10 ft).
- The input signal can share a common reference point with other signals.

DIFF input connections are recommended for greater signal integrity for any input signal that does not meet the preceding conditions.

In the single-ended modes, more electrostatic and magnetic noise couples into the signal connections than in DIFF configurations. The coupling is the result of differences in the signal path. Magnetic coupling is proportional to the area between the two signal conductors. Electrical coupling is a function of how much the electric field differs between the two conductors.

With this type of connection, the NI-PGIA rejects both the common-mode noise in the signal and the ground potential difference between the signal source and the device ground.

Refer to the [Using Non-Referenced Single-Ended \(NRSE\) Connections for Ground-Referenced Signal Sources](#) section for more information about NRSE connections.

When to Use Referenced Single-Ended (RSE) Connections with Ground-Referenced Signal Sources

Do *not* use RSE connections with ground-referenced signal sources. Use NRSE or DIFF connections instead.

As shown in the bottom-rightmost cell of Table 5-1, there can be a potential difference between AI GND and the ground of the sensor. In RSE mode, this ground loop causes measurement errors.

Using Differential Connections for Ground-Referenced Signal Sources

Figure 5-7 shows how to connect a ground-referenced signal source to the USB-6210/6211 device configured in DIFF mode.

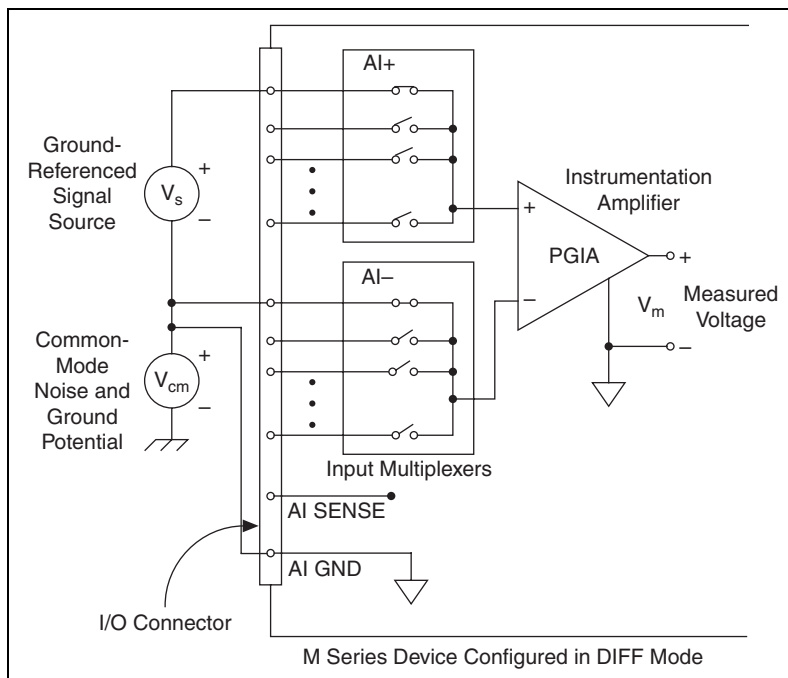

Figure 5-7. Differential Connections for Ground-Referenced Signal Sources

With this type of connection, the NI-PGIA rejects both the common-mode noise in the signal and the ground potential difference between the signal source and the device ground, shown as V_{cm} in the figure.

AI+ and AI- must both remain within ± 11 V of AI GND.

Using Non-Referenced Single-Ended (NRSE) Connections for Ground-Referenced Signal Sources

Figure 5-8 shows how to connect ground-reference signal sources to the USB-6210/6211 device in NRSE mode.

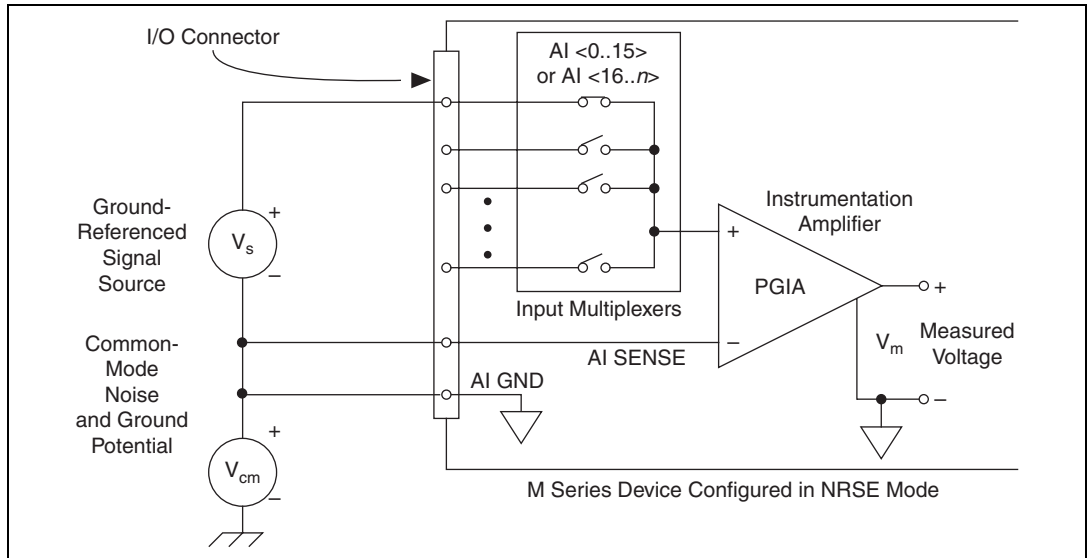

Figure 5-8. Single-Ended Connections for Ground-Referenced Signal Sources (NRSE Configuration)

AI+ and AI- must both remain within ± 11 V of AI GND.

To measure a single-ended, ground-referenced signal source, you must use the NRSE ground-reference setting. Connect the signal to one of AI <0..31> and connect the signal local ground reference to AI SENSE. AI SENSE is internally connected to the negative input of the NI-PGIA. Therefore, the ground point of the signal connects to the negative input of the NI-PGIA.

Any potential difference between the device ground and the signal ground appears as a common-mode signal at both the positive and negative inputs of the NI-PGIA, and this difference is rejected by the amplifier. If the input circuitry of a device were referenced to ground, as it is in the RSE ground-reference setting, this difference in ground potentials would appear as an error in the measured voltage.

Using the DAQ Assistant, you can configure the channels for RSE or NRSE input modes. Refer to the [Configuring AI Ground-Reference Settings in Software](#) section of Chapter 4, *Analog Input*, for more information about the DAQ Assistant.

Connecting AI Signals on the USB-6215/6218 Devices

You can connect the USB-6215/6218 directly to a variety of devices and other signal sources. Make sure the devices you connect to the USB-6215/6218 are compatible with the input specifications of the module.

When connecting various sources to the USB-6215/6218, you can use differential, single-ended, or a combination of single-ended and differential connections. Refer to Figures 6-1, 6-2, and 6-3 for diagrams of each connection type.



Note You must always connect AI GND to a local ground signal in your system using a low impedance connection. If you leave AI GND unconnected, you cannot ensure that AI <0..31> are within 10 V of AI GND, and your measurement may be unreliable.

Differential Measurements

To attain more accurate measurements and less noise, use a differential measurement configuration. A differential measurement configuration requires two inputs for each measurement.

Differential Pairs

Table 6-1 the signal pairs that are valid for differential connection configurations with the USB-6215/6218.

Table 6-1. I/O Connector Signals

Channel	Signal +	Signal -
0	AI 0	AI 8
1	AI 1	AI 9
2	AI 2	AI 10

Table 6-1. I/O Connector Signals (Continued)

Channel	Signal +	Signal -
3	A I3	AI 11
4	A I4	AI 12
5	A I5	AI 13
6	A I6	AI 14
7	A I7	AI 15
16*	AI 16	AI 24
17*	AI 17	AI 25
18*	AI 18	AI 26
19*	AI 19	AI 27
20*	AI 20	AI 28
21*	AI 21	AI 29
22*	AI 22	AI 30
23*	AI 23	AI 31
* USB-6218 devices only.		

Refer to Figure 6-1 for an illustration of a differential connection configuration.

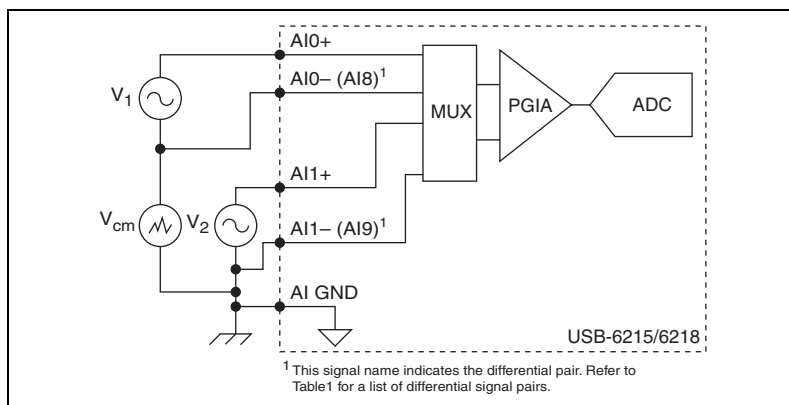

Figure 6-1. Connecting a Device to a USB-6215/6218 Using Differential Connections

The differential connection configuration allows the common-mode noise voltage, V_{cm} , to be rejected during the measurement of V_1 .

You must connect the negative lead of your sensors and AI GND to a local ground signal on your system.

Referenced Single-Ended (RSE) Measurements

Using the RSE measurement configuration allows the USB-6215/6218 to take measurements on all AI channels when all channels share a common ground. Refer to Figure 6-2 for an illustration of an RSE connection configuration.



Note If you leave the AI GND pin unconnected, the signals will float outside the working input range of the USB-6215/6218, which may result in unreliable measurements because there is no way to ensure that the input signal is within 10 V of AI GND.

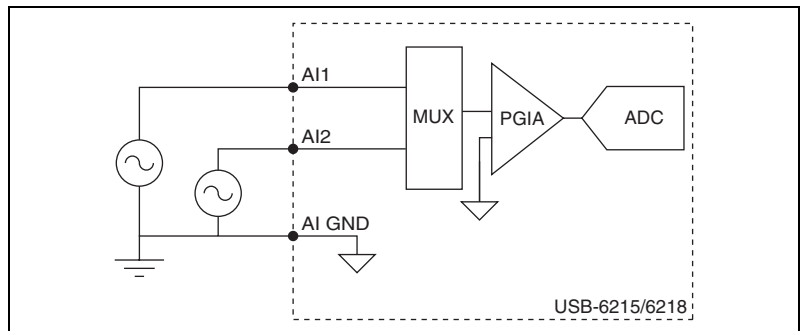

Figure 6-2. Connecting a Device to a USB-6215/6218 Using RSE Connections

In an RSE connection configuration, each input channel is measured with respect to AI GND.

Non-Referenced Single-Ended (NRSE) Measurements

To reach a compromise between RSE and differential measurements, you can use an NRSE measurement configuration. This configuration allows for a remote sense for the negative (–) input of the programmable gain instrumentation amplifier (PGIA) that is shared among all channels configured for NRSE mode. The behavior of this configuration is similar to the behavior of RSE connections but it provides improved noise rejection. Refer to Figure 6-3 for an illustration of an NRSE connection configuration.

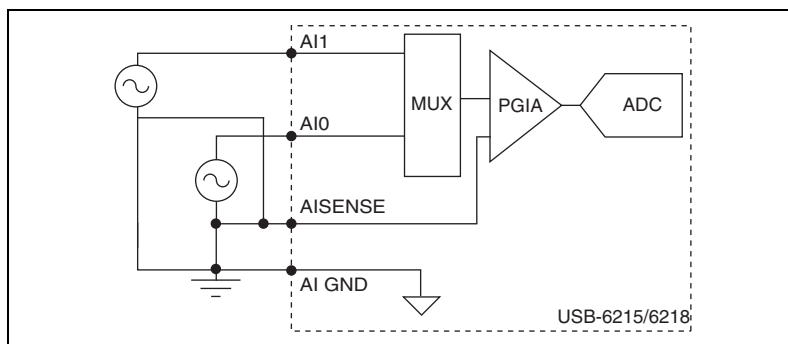

Figure 6-3. Connecting a Device to a USB-6215/6218 Using NRSE Connections

In the NRSE connection configuration, each input channel is measured with respect to AI SENSE.

Analog Output

Many M Series devices have analog output functionality. NI 621x devices that support analog output have two AO channels controlled by a single clock and capable of waveform generation. Refer to Appendix A, *Device-Specific Information*, for information about the capabilities of your device.

Figure 7-1 shows the analog output circuitry of M Series devices.

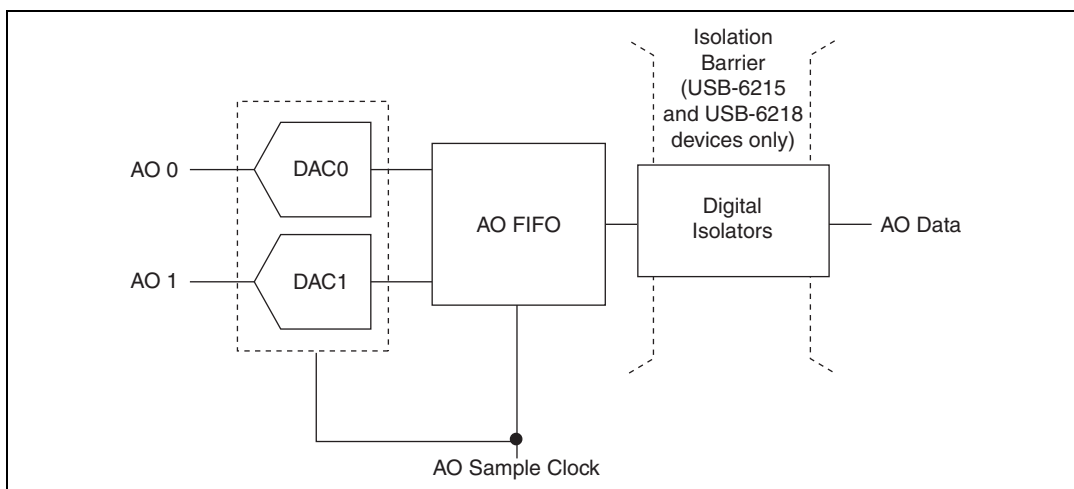

Figure 7-1. M Series Analog Output Circuitry

Analog Output Circuitry

DACs

Digital-to-analog converters (DACs) convert digital codes to analog voltages.

AO FIFO

The AO FIFO enables analog output waveform generation. It is a first-in-first-out (FIFO) memory buffer between the computer and the

DACs. It allows you to download the points of a waveform to your M Series device without host computer interaction.

AO Sample Clock

The AO Sample Clock signal reads a sample from the DAC FIFO and generates the AO voltage.

AO Range

The AO Range is ± 10 V for NI 621x devices.

Minimizing Glitches on the Output Signal

When you use a DAC to generate a waveform, you may observe glitches on the output signal. These glitches are normal; when a DAC switches from one voltage to another, it produces glitches due to released charges. The largest glitches occur when the most significant bit of the DAC code changes. You can build a lowpass deglitching filter to remove some of these glitches, depending on the frequency and nature of the output signal. Visit ni.com/support for more information about minimizing glitches.

Analog Output Data Generation Methods

When performing an analog output operation, you either can perform software-timed or hardware-timed generations.

Software-Timed Generations

With a software-timed generation, software controls the rate at which data is generated. Software sends a separate command to the hardware to initiate each DAC conversion. In NI-DAQmx, software-timed generations are referred to as on-demand timing. Software-timed generations are also referred to as immediate or static operations. They are typically used for writing a single value out, such as a constant DC voltage.

Hardware-Timed Generations

With a hardware-timed generation, a digital hardware signal controls the rate of the generation. This signal can be generated internally on your device or provided externally.

Hardware-timed generations have several advantages over software-timed acquisitions:

- The time between samples can be much shorter.
- The timing between samples can be deterministic.
- Hardware-timed acquisitions can use hardware triggering.

Hardware-timed operations can be buffered or non-buffered.

During hardware-timed AO generation, data is moved from a PC buffer to the onboard FIFO on the DAQ device using USB Signal Streams before it is written to the DACs one sample at a time. Buffered acquisitions allow for fast transfer rates because data is moved in large blocks rather than one point at a time.

One property of buffered I/O operations is the sample mode. The sample mode can be either finite or continuous.

Finite sample mode generation refers to the generation of a specific, predetermined number of data samples. Once the specified number of samples has been written out, the generation stops.

Continuous generation refers to the generation of an unspecified number of samples. Instead of generating a set number of data samples and stopping, a continuous generation continues until you stop the operation. There are several different methods of continuous generation that control what data is written. These methods are regeneration, FIFO regeneration and non-regeneration modes.

Regeneration is the repetition of the data that is already in the buffer. Standard regeneration is when data from the PC buffer is continually downloaded to the FIFO to be written out. New data can be written to the PC buffer at any time without disrupting the output.

With FIFO regeneration, the entire buffer is downloaded to the FIFO and regenerated from there. Once the data is downloaded, new data cannot be written to the FIFO. To use FIFO regeneration, the entire buffer must fit within the FIFO size. The advantage of using FIFO regeneration is that it does not require communication with the main host memory once the operation is started, thereby preventing any problems that may occur due to excessive bus traffic.

With non-regeneration, old data will not be repeated. New data must be continually written to the buffer. If the program does not write new data to

the buffer at a fast enough rate to keep up with the generation, the buffer will underflow and cause an error.

Analog Output Digital Triggering

Analog output supports two different triggering actions:

- Start trigger
- Pause trigger

A digital trigger can initiate these actions on the USB-621x devices. Refer to the *AO Start Trigger Signal* and *AO Pause Trigger Signal* sections for more information about these triggering actions.

Connecting Analog Output Signals

AO <0..1> are the voltage output signals for AO channels 0 and 1.
AO GND is the ground reference for AO <0..1>.

Figure 7-2 shows how to make AO connections to the device.

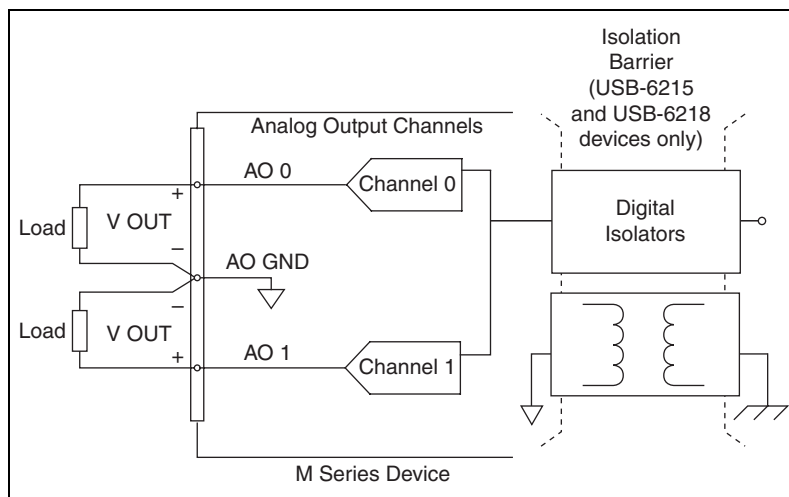

Figure 7-2. Analog Output Connections

Analog Output Timing Signals

Figure 7-3 summarizes all of the timing options provided by the analog output timing engine.

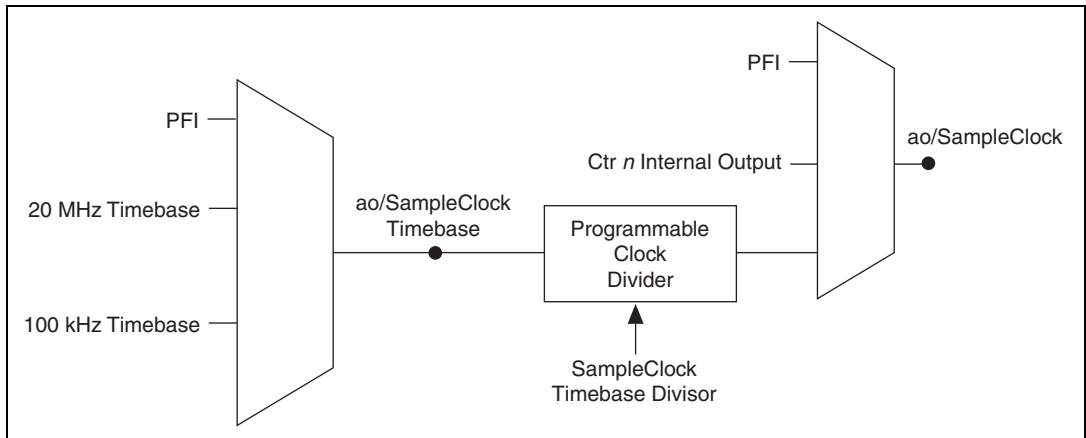

Figure 7-3. Analog Output Timing Options

USB M Series devices feature the following AO (waveform generation) timing signals.

- AO Start Trigger Signal
- AO Pause Trigger Signal
- AO Sample Clock Signal
- AO Sample Clock Timebase Signal

AO Start Trigger Signal

Use the AO Start Trigger (ao/StartTrigger) signal to initiate a waveform generation. If you do not use triggers, you can begin a generation with a software command.

Using a Digital Source

To use ao/StartTrigger, specify a source and an edge. The source can be one of the following signals:

- A software pulse
- PFI <0..3>, PFI <8..11>
- ai/StartTrigger

The source also can be one of several internal signals on your DAQ device. Refer to *Device Routing in MAX* in the *NI-DAQmx Help* or the *LabVIEW 8.x Help* for more information.

You also can specify whether the waveform generation begins on the rising edge or falling edge of ao/StartTrigger.

Routing AO Start Trigger Signal to an Output Terminal

You can route ao/StartTrigger out to any PFI <4..7> or PFI <12..15> terminal.

The output is an active high pulse.

AO Pause Trigger Signal

Use the AO Pause Trigger signal (ao/PauseTrigger) to mask off samples in a DAQ sequence. That is, when ao/PauseTrigger is active, no samples occur.

ao/PauseTrigger does not stop a sample that is in progress. The pause does not take effect until the beginning of the next sample.

If you are using any signal other than the onboard clock as the source of your sample clock, the generation resumes as soon as the pause trigger is deasserted and another edge of the sample clock is received, as shown in Figure 7-4.

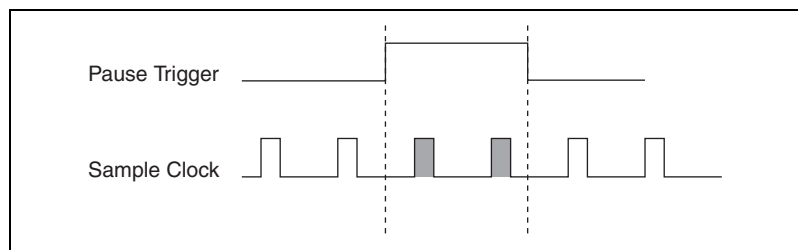

Figure 7-4. ao/PauseTrigger with Other Signal Source

Using a Digital Source

To use ao/PauseTrigger, specify a source and a polarity. The source can be the PFI <0..3> or PFI <8..11> signals.

The source also can be one of several other internal signals on your DAQ device. Refer to *Device Routing in MAX* in the *NI-DAQmx Help* or the *LabVIEW 8.x Help* for more information.

You also can specify whether the samples are paused when `ao/PauseTrigger` is at a logic high or low level.

AO Sample Clock Signal

Use the AO Sample Clock (`ao/SampleClock`) signal to initiate AO samples. Each sample updates the outputs of all of the DACs. You can specify an internal or external source for `ao/SampleClock`. You also can specify whether the DAC update begins on the rising edge or falling edge of `ao/SampleClock`.

Using an Internal Source

One of the following internal signals can drive `ao/SampleClock`.

- AO Sample Clock Timebase (divided down)
- Counter n Internal Output

A programmable internal counter divides down the AO Sample Clock Timebase signal.

Using an External Source

Use the external signals `PFI <0..3>` or `PFI <8..11>` as the source of `ao/SampleClock`.

Routing AO Sample Clock Signal to an Output Terminal

You can route `ao/SampleClock` (as an active low signal) out to any `PFI <4..7>` or `PFI <12..15>` terminal.

Other Timing Requirements

A counter on your device internally generates `ao/SampleClock` unless you select some external source. `ao/StartTrigger` starts the counter and either the software or hardware can stop it once a finite generation completes. When using an internally generated `ao/SampleClock`, you also can specify a configurable delay from `ao/StartTrigger` to the first `ao/SampleClock` pulse. By default, this delay is two ticks of `ao/SampleClockTimebase`.

Figure 7-5 shows the relationship of ao/SampleClock to ao/StartTrigger.

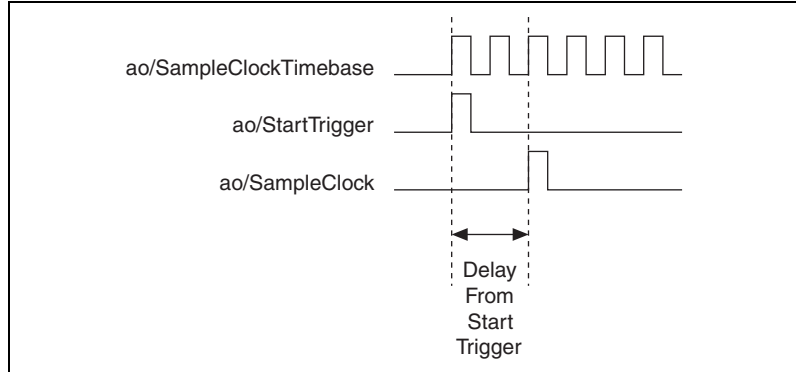

Figure 7-5. `ao/SampleClock` and `ao/StartTrigger`

AO Sample Clock Timebase Signal

The AO Sample Clock Timebase (`ao/SampleClockTimebase`) signal is divided down to provide a source for `ao/SampleClock`.

You can route any of the following signals to be the AO Sample Clock Timebase (`ao/SampleClockTimebase`) signal:

- 20 MHz Timebase
- 100 kHz Timebase
- PFI <0..3>, PFI <8..11>

`ao/SampleClockTimebase` is not available as an output on the I/O connector.

You might use `ao/SampleClockTimebase` if you want to use an external sample clock signal, but need to divide the signal down. If you want to use an external sample clock signal, but do not need to divide the signal, then you should use `ao/SampleClock` rather than `ao/SampleClockTimebase`.

Getting Started with AO Applications in Software

You can use an NI 621.x device in the following analog output applications.

- Single-point (on-demand) generation
- Finite generation
- Continuous generation
- Waveform generation

You can perform these generations through programmed I/O or USB Signal Stream data transfer mechanisms. Some of the applications also use start triggers and pause triggers.



Note For more information about programming analog output applications and triggers in software, refer to the *NI-DAQmx Help* or the *LabVIEW 8.x Help*.

Digital I/O

NI 621x devices have eight static digital input lines, P0.<0..7>. These lines also can be used as PFI inputs.

NI 621x devices have eight static digital output lines, P1.<0..8>. These lines also can be used as PFI output. By default the digital output lines are disabled (high impedance with a 47 k Ω pull down resistor) on power up. Software can enable or disable the entire port (software cannot enable individual lines). Once the port is enabled, you can individually configure each line to the following:

- Set a line to a static 0
- Set a line to a static 1
- Export a timing output signal to a line as a PFI pin

The voltage input and output levels and the current drive level of the DI and DO lines are listed in the *NI 621x Specifications*. Refer to Chapter 10, *PFI*, for more information on PFI inputs and outputs.

Figure 8-1 shows the circuitry of one DI line and one DO line. The following sections provide information about the various parts of the DIO circuit.

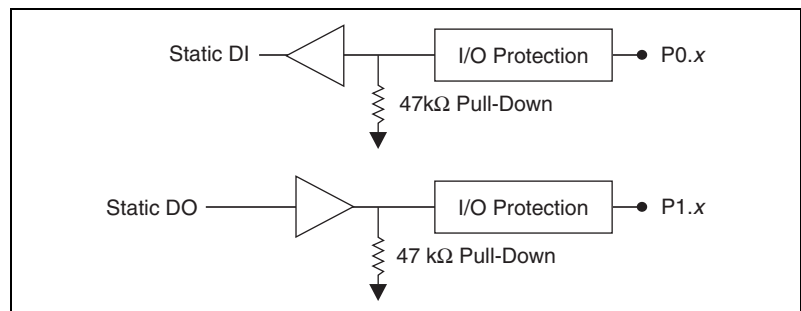

Figure 8-1. M Series Digital I/O Circuitry

The DI terminals are named P0.<0..7> on the NI 621x device I/O connector. The DO terminals are named P1.<0..7> on the NI 621x device I/O connector.

The voltage input and output levels and the current drive levels of the DIO lines are listed in the specifications of your device.

Static DIO

You can use static DI and DO lines to monitor or control digital signals.

All samples of static DI lines and updates of DO lines are software-timed.

I/O Protection

Each DI, DO, and PFI signal is protected against overvoltage, undervoltage, and overcurrent conditions as well as ESD events. However, you should avoid these fault conditions by following these guidelines.

- Do *not* connect a DO or PFI output lines to any external signal source, ground signal, or power supply.
- Understand the current requirements of the load connected to DO or PFI output signals. Do not exceed the specified current output limits of the DAQ device. NI has several signal conditioning solutions for digital applications requiring high current drive.
- Do *not* drive a DI or PFI input line with voltages outside of its normal operating range. The PFI or DI lines have a smaller operating range than the AI signals.

Increasing Current Drive

The total internal current limit for digital outputs and power down from the +5 V terminals is 50 mA. You can increase this internal current limit by supplying an external +5 V supply. Refer to the [+5 V Power as an Input](#) section of Chapter 3, [Connector Information](#).

Connecting Digital I/O Signals

The DI and DO signals, P0.<0..7> and P1.<0..7> are referenced to D GND. Digital input applications include receiving TTL signals and sensing external device states, such as the state of the switch shown in the figure. Digital output applications include sending TTL signals and driving external devices, such as the LED shown in Figure 8-2.

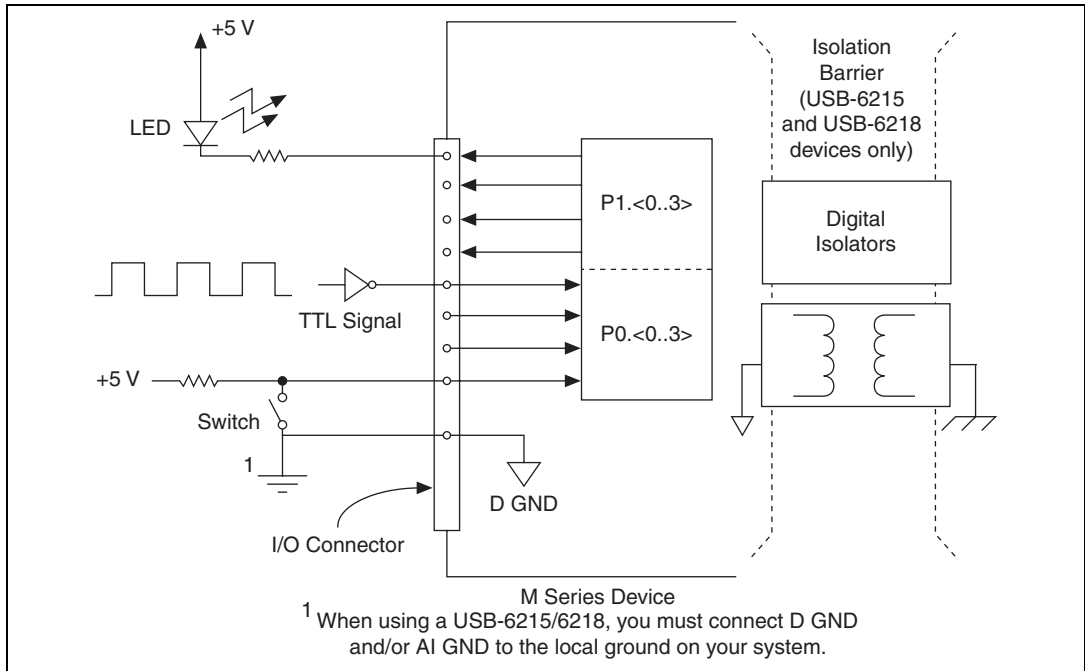

Figure 8-2. Digital I/O Connections



Caution Exceeding the maximum input voltage ratings, which are listed in the specifications document for each M Series device, can damage the DAQ device and the computer. NI is *not* liable for any damage resulting from such signal connections.

Getting Started with DIO Applications in Software

You can use the M Series device in the following digital I/O applications:

- Static digital input
- Static digital output
- Digital waveform generation
- Digital waveform acquisition
- DI change detection



Note For more information about programming digital I/O applications and triggers in software, refer to the *NI-DAQmx Help* or the *LabVIEW 8.x Help*.

Counters

M Series devices have two general-purpose 32-bit counter/timers and one frequency generator, as shown in Figure 9-1. The general-purpose counter/timers can be used for many measurement and pulse generation applications.

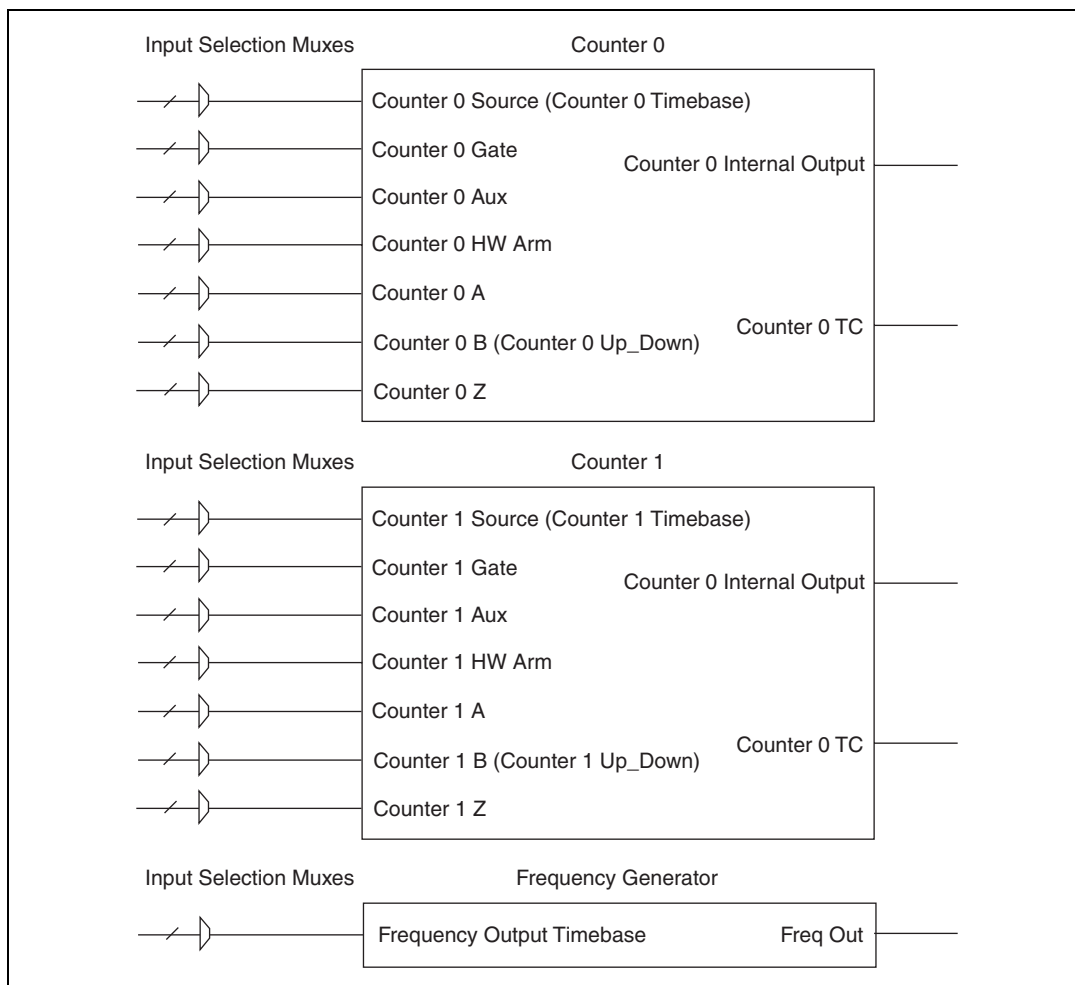

Figure 9-1. M Series Counters

The counters have seven input signals, although in most applications only a few inputs are used.

For information about connecting counter signals, refer to the [Default Counter/Timer Pinouts](#) section.

Counter Input Applications

Counting Edges

In edge counting applications, the counter counts edges on its Source after the counter is armed. You can configure the counter to count rising or falling edges on its Source input. You also can control the direction of counting (up or down).

The counter values can be read on demand or with a sample clock.

Single Point (On-Demand) Edge Counting

With single point (on-demand) edge counting, the counter counts the number of edges on the Source input after the counter is armed. *On-demand* refers to the fact that software can read the counter contents at any time without disturbing the counting process. Figure 9-2 shows an example of single point edge counting.

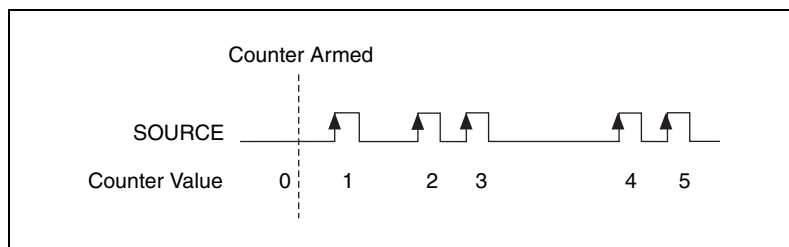

Figure 9-2. Single Point (On-Demand) Edge Counting

You also can use a pause trigger to pause (or gate) the counter. When the pause trigger is active, the counter ignores edges on its Source input. When the pause trigger is inactive, the counter counts edges normally.

You can route the pause trigger to the Gate input of the counter. You can configure the counter to pause counting when the pause trigger is high or when it is low. Figure 9-3 shows an example of on-demand edge counting with a pause trigger.

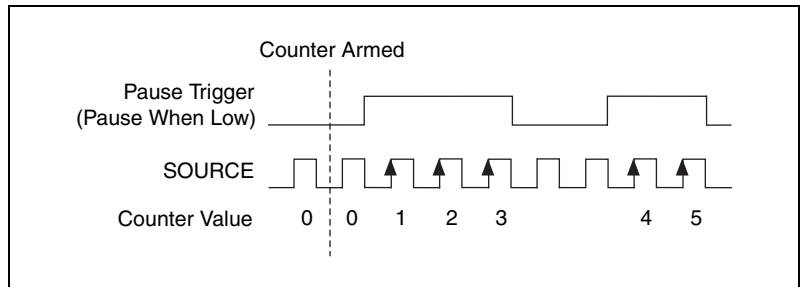

Figure 9-3. Single Point (On-Demand) Edge Counting with Pause Trigger

Buffered (Sample Clock) Edge Counting

With buffered edge counting (edge counting using a sample clock), the counter counts the number of edges on the Source input after the counter is armed. The value of the counter is sampled on each active edge of a sample clock. A USB Signal Stream transfers the sampled values to host memory.

The count values returned are the cumulative counts since the counter armed event. That is, the sample clock does not reset the counter.

You can route the counter sample clock to the Gate input of the counter. You can configure the counter to sample on the rising or falling edge of the sample clock.

Figure 9-4 shows an example of buffered edge counting. Notice that counting begins when the counter is armed, which occurs before the first active edge on Gate.

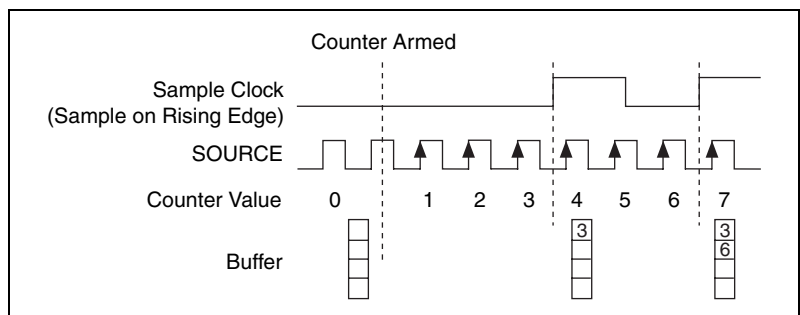

Figure 9-4. Buffered (Sample Clock) Edge Counting

Non-Cumulative Buffered Edge Counting

Non-cumulative edge counting is similar to buffered (sample clock) edge counting. However, the counter resets after each active edge of the Sample Clock. You can route the Sample Clock to the Gate input of the counter.

Figure 9-5 shows an example of non-cumulative buffered edge counting.

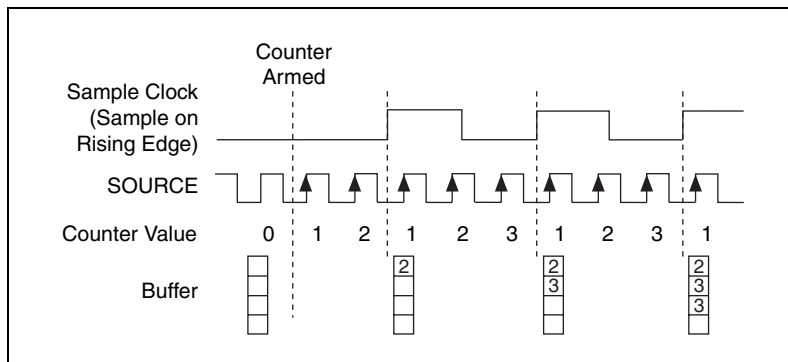

Figure 9-5. Non-Cumulative Buffered Edge Counting

Notice that the first count interval begins when the counter is armed, which occurs before the first active edge on Gate.

Note that if you are using an external signal as the Source, at least one Source pulse should occur between each active edge of the Gate signal. This condition ensures that correct values are returned by the counter. If this condition is not met, consider using duplicate count prevention, described in the [Duplicate Count Prevention](#) section.

Controlling the Direction of Counting

In edge counting applications, the counter can count up or down. You can configure the counter to do the following:

- Always count up
- Always count down
- Count up when the Counter n B input is high; count down when it is low

For information about connecting counter signals, refer to the [Default Counter/Timer Pinouts](#) section.

Pulse-Width Measurement

In pulse-width measurements, the counter measures the width of a pulse on its Gate input signal. You can configure the counter to measure the width of high pulses or low pulses on the Gate signal.

You can route an internal or external periodic clock signal (with a known period) to the Source input of the counter. The counter counts the number of rising (or falling) edges on the Source signal while the pulse on the Gate signal is active.

You can calculate the pulse width by multiplying the period of the Source signal by the number of edges returned by the counter.

A pulse-width measurement will be accurate even if the counter is armed while a pulse train is in progress. If a counter is armed while the pulse is in the active state, it will wait for the next transition to the active state to begin the measurement.

Single Pulse-Width Measurement

With single pulse-width measurement, the counter counts the number of edges on the Source input while the Gate input remains active. When the Gate input goes inactive, the counter stores the count in a hardware save register and ignores other edges on the Gate and Source inputs. Software then reads the stored count.

Figure 9-6 shows an example of a single pulse-width measurement.

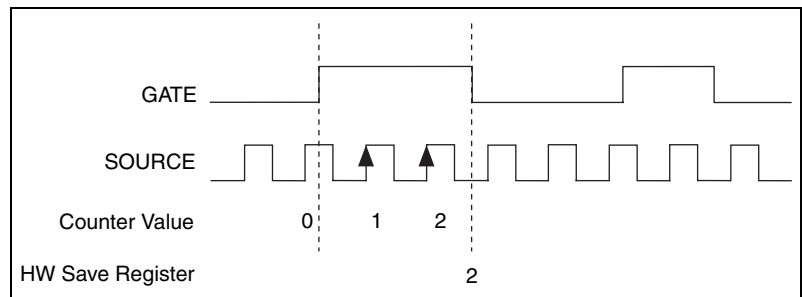

Figure 9-6. Single Pulse-Width Measurement

Buffered Pulse-Width Measurement

Buffered pulse-width measurement is similar to single pulse-width measurement, but buffered pulse-width measurement takes measurements over multiple pulses.

The counter counts the number of edges on the Source input while the Gate input remains active. On each trailing edge of the Gate signal, the counter stores the count in a hardware save register. A USB Signal Stream transfers the stored values to host memory.

Figure 9-7 shows an example of a buffered pulse-width measurement.

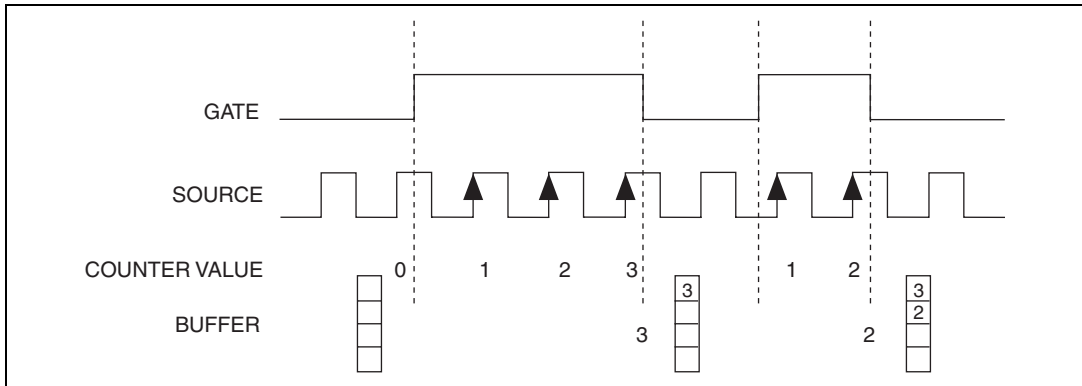

Figure 9-7. Buffered Pulse-Width Measurement

Note that if you are using an external signal as the Source, at least one Source pulse should occur between each active edge of the Gate signal. This condition ensures that correct values are returned by the counter. If this condition is not met, consider using duplicate count prevention, described in the [Duplicate Count Prevention](#) section.

For information about connecting counter signals, refer to the [Default Counter/Timer Pinouts](#) section.

Period Measurement

In period measurements, the counter measures a period on its Gate input signal after the counter is armed. You can configure the counter to measure the period between two rising edges or two falling edges of the Gate input signal.

You can route an internal or external periodic clock signal (with a known period) to the Source input of the counter. The counter counts the number of rising (or falling) edges occurring on the Source input between the two active edges of the Gate signal.

You can calculate the period of the Gate input by multiplying the period of the Source signal by the number of edges returned by the counter.

Single Period Measurement

With single period measurement, the counter counts the number of rising (or falling) edges on the Source input occurring between two active edges of the Gate input. On the second active edge of the Gate input, the counter stores the count in a hardware save register and ignores other edges on the Gate and Source inputs. Software then reads the stored count.

Figure 9-8 shows an example of a single period measurement.

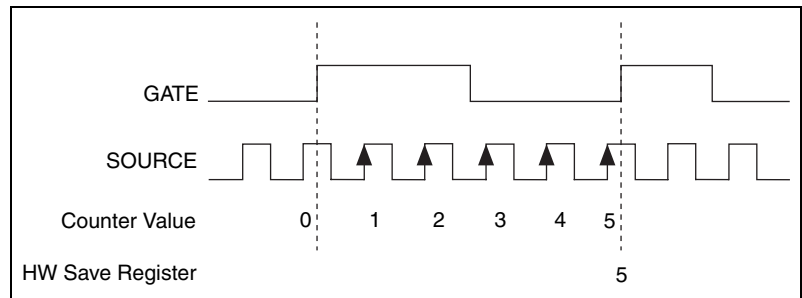

Figure 9-8. Single Period Measurement

Buffered Period Measurement

Buffered period measurement is similar to single period measurement, but buffered period measurement measures multiple periods.

The counter counts the number of rising (or falling) edges on the Source input between each pair of active edges on the Gate input. At the end of each period on the Gate signal, the counter stores the count in a hardware save register. A USB Signal Stream transfers the stored values to host memory.

The counter begins on the first active edge of the Gate after it is armed. The arm usually occurs in the middle of a period of the Gate input. The counter does not store a measurement for this incomplete period.

Figure 9-9 shows an example of a buffered period measurement. In this example, a period is defined by two consecutive rising edges.

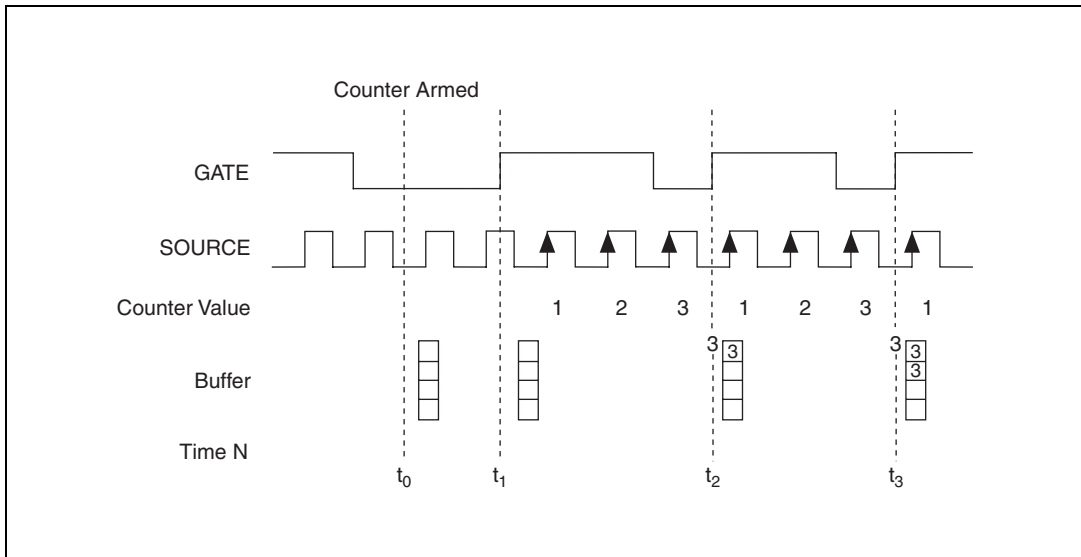

Figure 9-9. Buffered Period Measurement

Table 9-1. Time N Descriptions

t_0	At t_0 , the counter is armed. No measurements are taken until the counter is armed.
t_1	The rising edge of Gate indicates the beginning of the first period to measure. The counter begins counting rising edges of Source.
t_2	The rising edge of Gate indicates the end of the first period. The USB M Series device stores the counter value in the buffer.
t_3	The rising edge of Gate indicates the end of the second period. The USB M Series device stores the counter value in the buffer.

Note that if you are using an external signal as the Source, at least one Source pulse should occur between each active edge of the Gate signal. This condition ensures that correct values are returned by the counter. If this condition is not met, the counter returns a zero. Refer to the [Duplicate Count Prevention](#) section for more information.

For information about connecting counter signals, refer to the [Default Counter/Timer Pinouts](#) section.

Semi-Period Measurement

In semi-period measurements, the counter measures a semi-period on its Gate input signal after the counter is armed. A semi-period is the time between any two consecutive edges on the Gate input.

You can route an internal or external periodic clock signal (with a known period) to the Source input of the counter. The counter counts the number of rising (or falling) edges occurring on the Source input between two edges of the Gate signal.

You can calculate the semi-period of the Gate input by multiplying the period of the Source signal by the number of edges returned by the counter.

Single Semi-Period Measurement

Single semi-period measurement is equivalent to single pulse-width measurement.

Buffered Semi-Period Measurement

In buffered semi-period measurement, on each edge of the Gate signal, the counter stores the count in a hardware save register. A USB Signal Stream transfers the stored values to host memory.

The counter begins counting on the first active edge of the Gate after it is armed. The arm usually occurs between edges on the Gate input. The counter does not store a value for this incomplete semi-period.

Figure 9-10 shows an example of a buffered semi-period measurement.

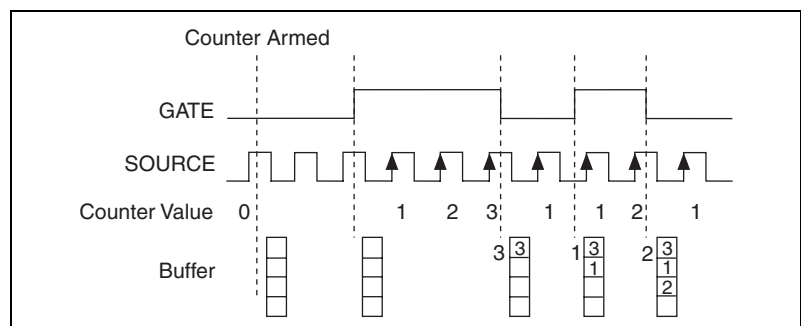

Figure 9-10. Buffered Semi-Period Measurement

Note that if you are using an external signal as the Source, at least one Source pulse should occur between each active edge of the Gate signal.

This condition ensures that correct values are returned by the counter. If this condition is not met, the counter returns a zero. Refer to the [Duplicate Count Prevention](#) section for more information.

For information about connecting counter signals, refer to the [Default Counter/Timer Pinouts](#) section.

Frequency Measurement

You can use the counters to measure frequency in several different ways. You can choose one of the following methods depending on your application.

Method 1—Measure Low Frequency with One Counter

In this method, you measure one period of your signal using a known timebase. This method is good for low frequency signals.

You can route the signal to measure (F1) to the Gate of a counter. You can route a known timebase (Ft) to the Source of the counter. The known timebase can be 80MHzTimebase. For signals that might be slower than 0.02 Hz, use a slower known timebase.

You can configure the counter to measure one period of the gate signal. The frequency of F1 is the inverse of the period. Figure 9-11 illustrates this method.

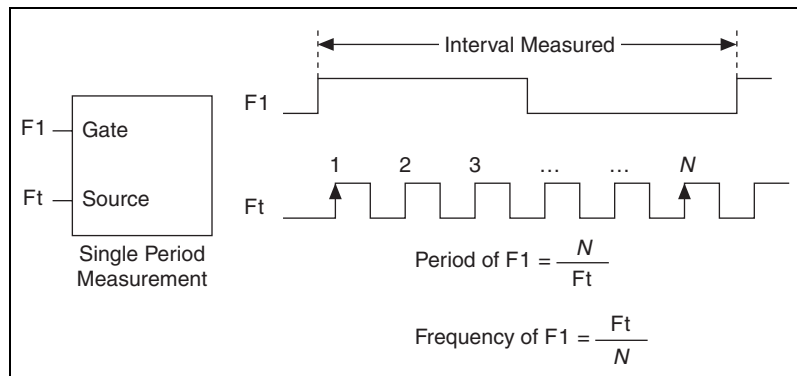

Figure 9-11. Method 1

Method 1b—Measure Low Frequency with One Counter (Averaged)

In this method, you measure several periods of your signal using a known timebase. This method is good for low to medium frequency signals.

You can route the signal to measure (F1) to the Gate of a counter. You can route a known timebase (Ft) to the Source of the counter. The known timebase can be 80MHzTimebase. For signals that might be slower than 0.02 Hz, use a slower known timebase.

You can configure the counter to make K + 1 buffered period measurements. Recall that the first period measurement in the buffer should be discarded.

Average the remaining K period measurements to determine the average period of F1. The frequency of F1 is the inverse of the average period. Figure 9-12 illustrates this method.

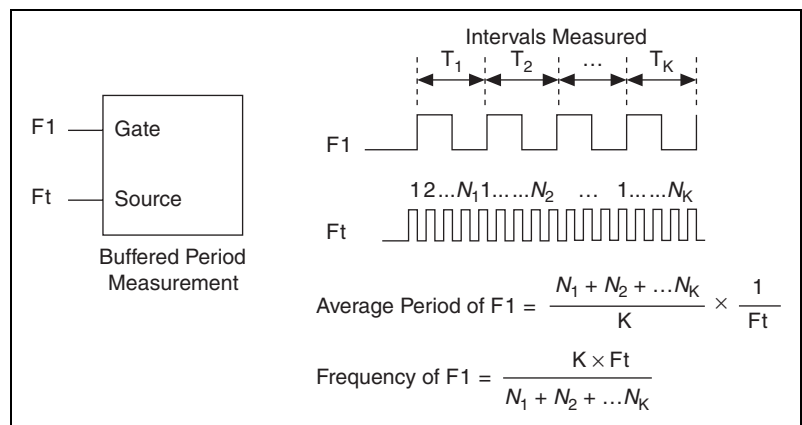

Figure 9-12. Method 1b

Method 2—Measure High Frequency with Two Counters

In this method, you measure one pulse of a known width using your signal and derive the frequency of your signal from the result. This method is good for high frequency signals.

In this method, you route a pulse of known duration (T) to the Gate of a counter. You can generate the pulse using a second counter. You also can

generate the pulse externally and connect it to a PFI terminal. You only need to use one counter if you generate the pulse externally.

Route the signal to measure (F1) to the Source of the counter. Configure the counter for a single pulse-width measurement. Suppose you measure the width of pulse T to be N periods of F1. Then the frequency of F1 is N/T .

Figure 9-13 illustrates this method. Another option would be to measure the width of a known period instead of a known pulse.

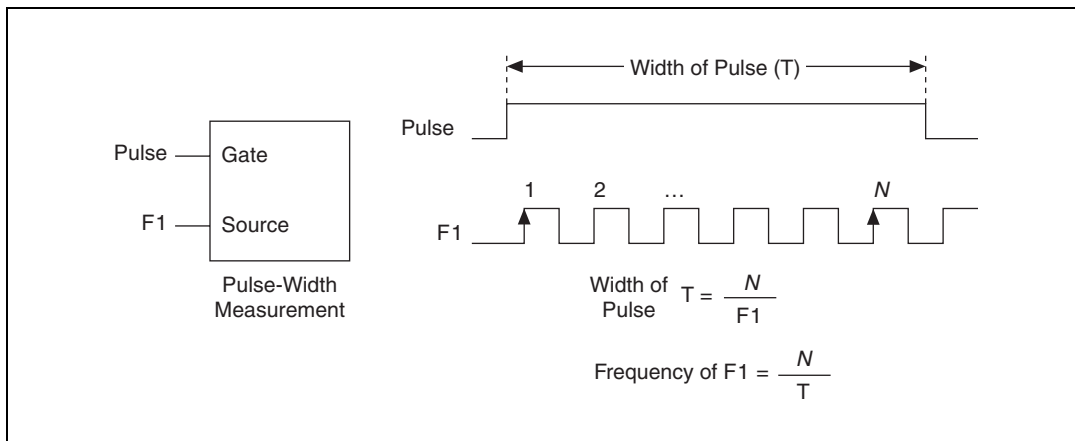

Figure 9-13. Method 2

Method 3—Measure Large Range of Frequencies Using Two Counters

By using two counters, you can accurately measure a signal that might be high or low frequency. This technique is called reciprocal frequency measurement. In this method, you generate a long pulse using the signal to measure. You then measure the long pulse with a known timebase. The M Series device can measure this long pulse more accurately than the faster input signal.

You can route the signal to measure to the Source input of Counter 0, as shown in Figure 9-14. Assume this signal to measure has frequency F1. Configure Counter 0 to generate a single pulse that is the width of N periods of the source input signal.

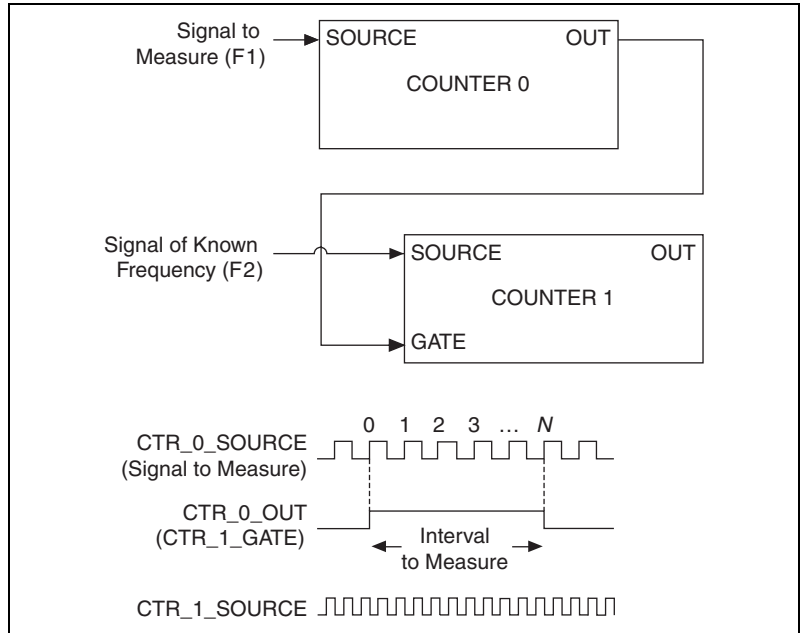

Figure 9-14. Method 3

Then route the Counter 0 Internal Output signal to the Gate input of Counter 1. You can route a signal of known frequency (F2) to the Counter 1 Source input. F2 can be 80MHzTimebase. For signals that might be slower than 0.02 Hz, use a slower known timebase. Configure Counter 1 to perform a single pulse-width measurement. Suppose the result is that the pulse width is J periods of the F2 clock.

From Counter 0, the length of the pulse is $N/F1$. From Counter 1, the length of the same pulse is $J/F2$. Therefore, the frequency of F1 is given by $F1 = F2 * (N/J)$.

Choosing a Method for Measuring Frequency

The best method to measure frequency depends on several factors including the expected frequency of the signal to measure, the desired accuracy, how many counters are available, and how long the measurement can take.

- Method 1 uses only one counter. It is a good method for many applications. However, the accuracy of the measurement decreases as the frequency increases.

Consider a frequency measurement on a 50 kHz signal using an 80 MHz Timebase. This frequency corresponds to 1600 cycles of the

80 MHz Timebase. Your measurement may return 1600 ± 1 cycles depending on the phase of the signal with respect to the timebase. As your frequency becomes larger, this error of ± 1 cycle becomes more significant; Table 9-2 illustrates this point.

Table 9-2. Frequency Measurement Method 1

Task	Equation	Example 1	Example 2
Actual Frequency to Measure	F1	50 kHz	5 MHz
Timebase Frequency	Ft	80 MHz	80 MHz
Actual Number of Timebase Periods	Ft/F1	1600	16
Worst Case Measured Number of Timebase Periods	$(Ft/F1) - 1$	1599	15
Measured Frequency	$Ft F1 / (Ft - F1)$	50.125 kHz	5.33 MHz
Error	$[Ft F1 / (Ft - F1)] - F1$	125 kHz	333 kHz
Error %	$[Ft / (Ft - F1)] - 1$	0.06%	6.67%

- Method 1b (measuring K periods of F1) improves the accuracy of the measurement. A disadvantage of Method 1b is that you have to take K + 1 measurements. These measurements take more time and consume some of the available USB bandwidth.
- Method 2 is accurate for high frequency signals. However, the accuracy decreases as the frequency of the signal to measure decreases. At very low frequencies, Method 2 may be too inaccurate for your application. Another disadvantage of Method 2 is that it requires two counters (if you cannot provide an external signal of known width). An advantage of Method 2 is that the measurement completes in a known amount of time.
- Method 3 measures high and low frequency signals accurately. However, it requires two counters.

Table 9-3 summarizes some of the differences in methods of measuring frequency.

Table 9-3. Frequency Measurement Method Comparison

Method	Number of Counters Used	Number of Measurements Returned	Measures High Frequency Signals Accurately	Measures Low Frequency Signals Accurately
1	1	1	Poor	Good
1b	1	Many	Fair	Good
2	1 or 2	1	Good	Poor
3	2	1	Good	Good

For information about connecting counter signals, refer to the [Default Counter/Timer Pinouts](#) section.

Position Measurement

You can use the counters to perform position measurements with quadrature encoders or two-pulse encoders. You can measure angular position with X1, X2, and X4 angular encoders. Linear position can be measured with two-pulse encoders. You can choose to do either a single point (on-demand) position measurement or a buffered (sample clock) position measurement. You must arm a counter to begin position measurements.

Measurements Using Quadrature Encoders

The counters can perform measurements of quadrature encoders that use X1, X2, or X4 encoding. A quadrature encoder can have up to three channels—channels A, B, and Z.

X1 Encoding

When channel A leads channel B in a quadrature cycle, the counter increments. When channel B leads channel A in a quadrature cycle, the counter decrements. The amount of increments and decrements per cycle depends on the type of encoding—X1, X2, or X4.

Figure 9-15 shows a quadrature cycle and the resulting increments and decrements for X1 encoding. When channel A leads channel B, the increment occurs on the rising edge of channel A. When channel B leads channel A, the decrement occurs on the falling edge of channel A.

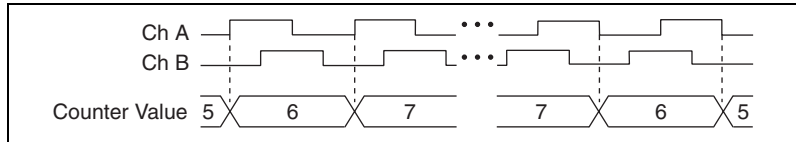

Figure 9-15. X1 Encoding

X2 Encoding

The same behavior holds for X2 encoding except the counter increments or decrements on each edge of channel A, depending on which channel leads the other. Each cycle results in two increments or decrements, as shown in Figure 9-16.

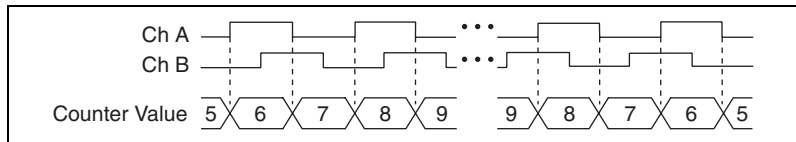

Figure 9-16. X2 Encoding

X4 Encoding

Similarly, the counter increments or decrements on each edge of channels A and B for X4 encoding. Whether the counter increments or decrements depends on which channel leads the other. Each cycle results in four increments or decrements, as shown in Figure 9-17.

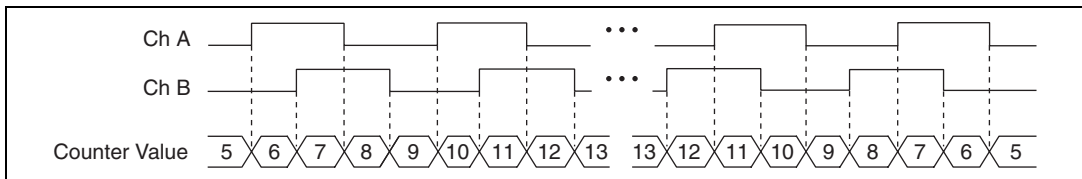

Figure 9-17. X4 Encoding

Channel Z Behavior

Some quadrature encoders have a third channel, channel Z, which is also referred to as the index channel. A high level on channel Z causes the counter to be reloaded with a specified value in a specified phase of the quadrature cycle. You can program this reload to occur in any one of the four phases in a quadrature cycle.

Channel Z behavior—when it goes high and how long it stays high—differs with quadrature encoder designs. You must refer to the documentation for your quadrature encoder to obtain timing of channel Z with respect to channels A and B. You must then ensure that channel Z is high during at least a portion of the phase you specify for reload. For instance, in Figure 9-18, channel Z is never high when channel A is high and channel B is low. Thus, the reload must occur in some other phase.

In Figure 9-18, the reload phase is when both channel A and channel B are low. The reload occurs when this phase is true and channel Z is high. Incrementing and decrementing takes priority over reloading. Thus, when the channel B goes low to enter the reload phase, the increment occurs first. The reload occurs within one maximum timebase period after the reload phase becomes true. After the reload occurs, the counter continues to count as before. The figure illustrates channel Z reload with X4 decoding.

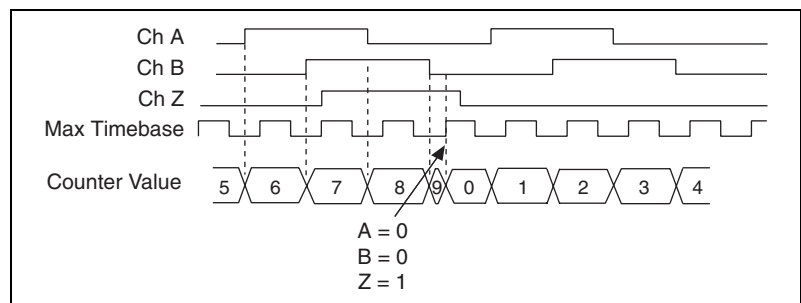

Figure 9-18. Channel Z Reload with X4 Decoding

Measurements Using Two Pulse Encoders

The counter supports two pulse encoders that have two channels—channels A and B.

The counter increments on each rising edge of channel A. The counter decrements on each rising edge of channel B, as shown in Figure 9-19.

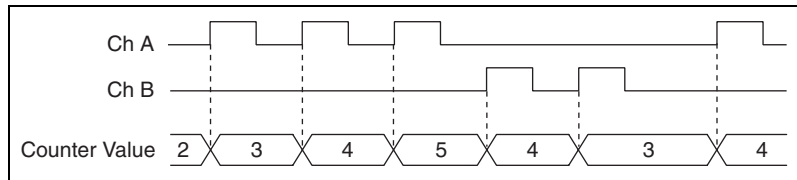

Figure 9-19. Measurements Using Two Pulse Encoders

For information about connecting counter signals, refer to the [Default Counter/Timer Pinouts](#) section.

Two-Signal Edge-Separation Measurement

Two-signal edge-separation measurement is similar to pulse-width measurement, except that there are two measurement signals—Aux and Gate. An active edge on the Aux input starts the counting and an active edge on the Gate input stops the counting. You must arm a counter to begin a two edge separation measurement.

After the counter has been armed and an active edge occurs on the Aux input, the counter counts the number of rising (or falling) edges on the Source. The counter ignores additional edges on the Aux input.

The counter stops counting upon receiving an active edge on the Gate input. The counter stores the count in a hardware save register.

You can configure the rising or falling edge of the Aux input to be the active edge. You can configure the rising or falling edge of the Gate input to be the active edge.

Use this type of measurement to count events or measure the time that occurs between edges on two signals. This type of measurement is sometimes referred to as start/stop trigger measurement, second gate measurement, or A-to-B measurement.

Single Two-Signal Edge-Separation Measurement

With single two-signal edge-separation measurement, the counter counts the number of rising (or falling) edges on the Source input occurring between an active edge of the Gate signal and an active edge of the Aux signal. The counter then stores the count in a hardware save register and ignores other edges on its inputs. Software then reads the stored count.

Figure 9-20 shows an example of a single two-signal edge-separation measurement.

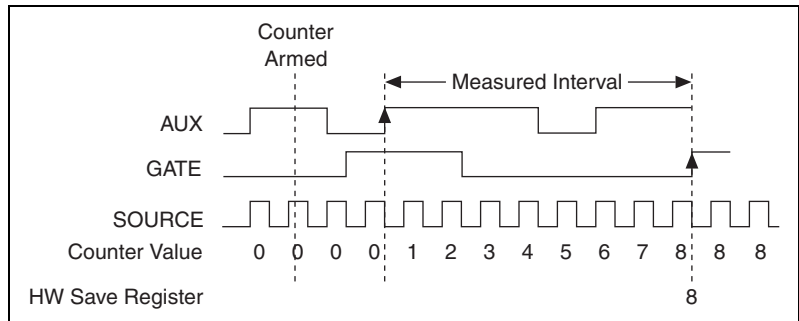

Figure 9-20. Single Two-Signal Edge-Separation Measurement

Buffered Two-Signal Edge-Separation Measurement

Buffered and single two-signal edge-separation measurements are similar, but buffered measurement measures multiple intervals.

The counter counts the number of rising (or falling) edges on the Source input occurring between an active edge of the Gate signal and an active edge of the Aux signal. The counter then stores the count in a hardware save register. On the next active edge of the Gate signal, the counter begins another measurement. A USB Signal Stream transfers the stored values to host memory.

Figure 9-21 shows an example of a buffered two-signal edge-separation measurement.

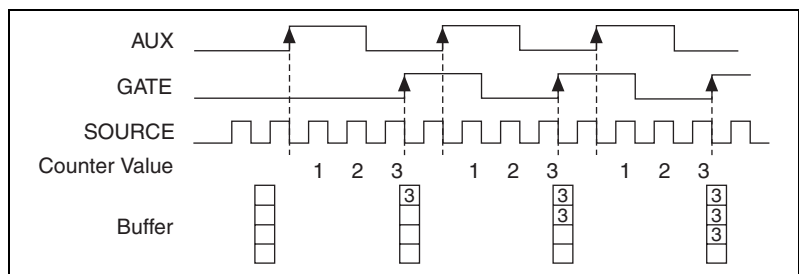

Figure 9-21. Buffered Two-Signal Edge-Separation Measurement

For information about connecting counter signals, refer to the [Default Counter/Timer Pinouts](#) section.

Counter Output Applications

Simple Pulse Generation

Single Pulse Generation

The counter can output a single pulse. The pulse appears on the Counter n Internal Output signal of the counter.

You can specify a delay from when the counter is armed to the beginning of the pulse. The delay is measured in terms of a number of active edges of the Source input.

You can specify a pulse width. The pulse width is also measured in terms of a number of active edges of the Source input. You also can specify the active edge of the Source input (rising or falling).

Figure 9-22 shows a generation of a pulse with a pulse delay of four and a pulse width of three (using the rising edge of Source).

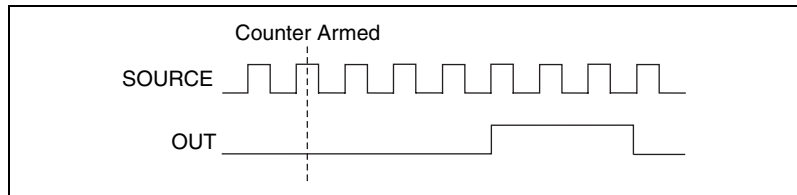

Figure 9-22. Single Pulse Generation

Single Pulse Generation with Start Trigger

The counter can output a single pulse in response to one pulse on a hardware Start Trigger signal. The pulse appears on the Counter n Internal Output signal of the counter.

You can route the Start Trigger signal to the Gate input of the counter. You can specify a delay from the Start Trigger to the beginning of the pulse. You also can specify the pulse width. The delay and pulse width are measured in terms of a number of active edges of the Source input.

After the Start Trigger signal pulses once, the counter ignores the Gate input.

Figure 9-23 shows a generation of a pulse with a pulse delay of four and a pulse width of three (using the rising edge of Source).

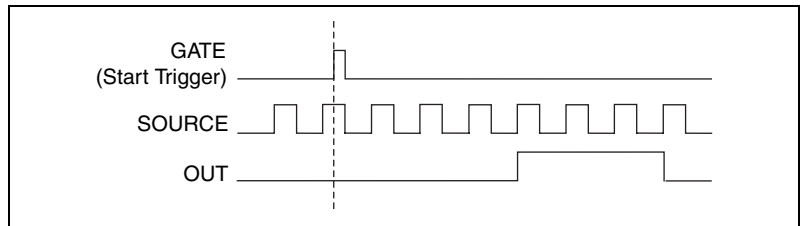

Figure 9-23. Single Pulse Generation with Start Trigger

Retriggerable Single Pulse Generation

The counter can output a single pulse in response to each pulse on a hardware Start Trigger signal. The pulses appear on the Counter n Internal Output signal of the counter.

You can route the Start Trigger signal to the Gate input of the counter. You can specify a delay from the Start Trigger to the beginning of each pulse. You also can specify the pulse width. The delay and pulse width are measured in terms of a number of active edges of the Source input.

The counter ignores the Gate input while a pulse generation is in progress. After the pulse generation is finished, the counter waits for another Start Trigger signal to begin another pulse generation.

Figure 9-24 shows a generation of two pulses with a pulse delay of five and a pulse width of three (using the rising edge of Source).

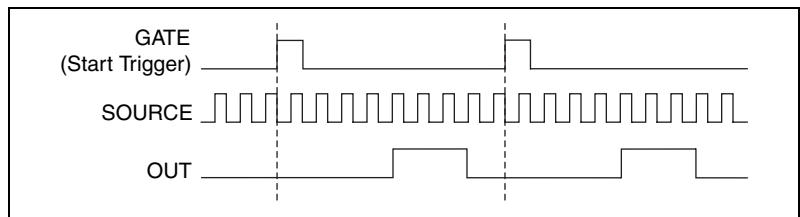

Figure 9-24. Retriggerable Single Pulse Generation

For information about connecting counter signals, refer to the [Default Counter/Timer Pinouts](#) section.

Pulse Train Generation

Continuous Pulse Train Generation

This function generates a train of pulses with programmable frequency and duty cycle. The pulses appear on the Counter n Internal Output signal of the counter.

You can specify a delay from when the counter is armed to the beginning of the pulse train. The delay is measured in terms of a number of active edges of the Source input.

You specify the high and low pulse widths of the output signal. The pulse widths are also measured in terms of a number of active edges of the Source input. You also can specify the active edge of the Source input (rising or falling).

The counter can begin the pulse train generation as soon as the counter is armed, or in response to a hardware Start Trigger. You can route the Start Trigger to the Gate input of the counter.

You also can use the Gate input of the counter as a Pause Trigger (if it is not used as a Start Trigger). The counter pauses pulse generation when the Pause Trigger is active.

Figure 9-25 shows a continuous pulse train generation (using the rising edge of Source).

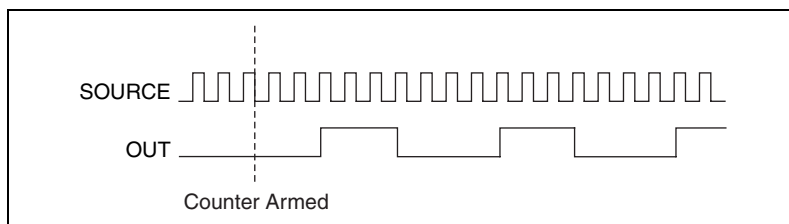

Figure 9-25. Continuous Pulse Train Generation

Continuous pulse train generation is sometimes called frequency division. If the high and low pulse widths of the output signal are M and N periods, then the frequency of the Counter n Internal Output signal is equal to the frequency of the Source input divided by $M + N$.

For information about connecting counter signals, refer to the [Default Counter/Timer Pinouts](#) section.

Frequency Generation

You can generate a frequency by using a counter in pulse train generation mode or by using the frequency generator circuit.

Using the Frequency Generator

The frequency generator can output a square wave at many different frequencies. The frequency generator is independent of the two general-purpose 32-bit counter/timer modules on M Series devices.

Figure 9-26 shows a block diagram of the frequency generator.

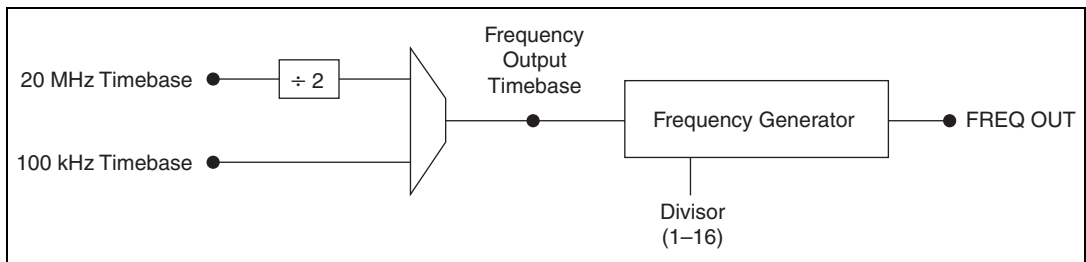

Figure 9-26. Frequency Generator Block Diagram

The frequency generator generates the Frequency Output signal. The Frequency Output signal is the Frequency Output Timebase divided by a number you select from 1 to 16. The Frequency Output Timebase can be either the 20 MHz Timebase divided by 2 or the 100 kHz Timebase.

The duty cycle of Frequency Output is 50% if the divider is either 1 or an even number. For an odd divider, suppose the divider is set to D . In this case, Frequency Output is low for $(D + 1)/2$ cycles and high for $(D - 1)/2$ cycles of the Frequency Output Timebase.

Figure 9-27 shows the output waveform of the frequency generator when the divider is set to 5.

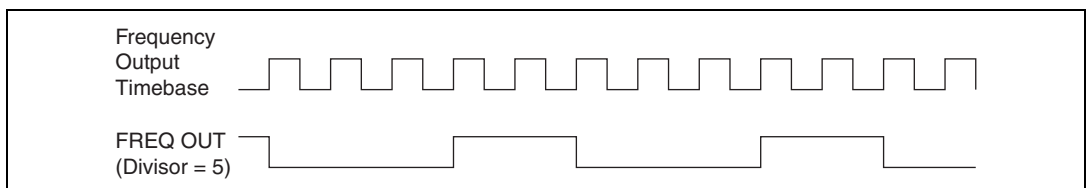

Figure 9-27. Frequency Generator Output Waveform

Frequency Output can be routed out to any PFI <4..7> or PFI <12..15> terminal. All PFI terminals are set to high-impedance at startup. The FREQ OUT signal also can be routed to DO Sample Clock and DI Sample Clock.

In software, program the frequency generator as you would program one of the counters for pulse train generation.

For information about connecting counter signals, refer to the [Default Counter/Timer Pinouts](#) section.

Frequency Division

The counters can generate a signal with a frequency that is a fraction of an input signal. This function is equivalent to continuous pulse train generation.

For information about connecting counter signals, refer to the [Default Counter/Timer Pinouts](#) section.

Pulse Generation for ETS

In this application, the counter produces a pulse on the output a specified delay after an active edge on Gate. After each active edge on Gate, the counter cumulatively increments the delay between the Gate and the pulse on the output by a specified amount. Thus, the delay between the Gate and the pulse produced successively increases.



Note ETS = Equivalent Time Sampling.

The increase in the delay value can be between 0 and 255. For instance, if you specify the increment to be 10, the delay between the active Gate edge and the pulse on the output will increase by 10 every time a new pulse is generated.

Suppose you program your counter to generate pulses with a delay of 100 and pulse width of 200 each time it receives a trigger. Furthermore, suppose you specify the delay increment to be 10. On the first trigger, your pulse delay will be 100, on the second it will be 110, on the third it will be 120; the process will repeat in this manner until the counter is disarmed. The counter ignores any Gate edge that is received while the pulse triggered by the previous Gate edge is in progress.

The waveform thus produced at the counter's output can be used to provide timing for undersampling applications where a digitizing system can sample repetitive waveforms that are higher in frequency than the Nyquist

frequency of the system. Figure 9-28 shows an example of pulse generation for ETS; the delay from the trigger to the pulse increases after each subsequent Gate active edge.

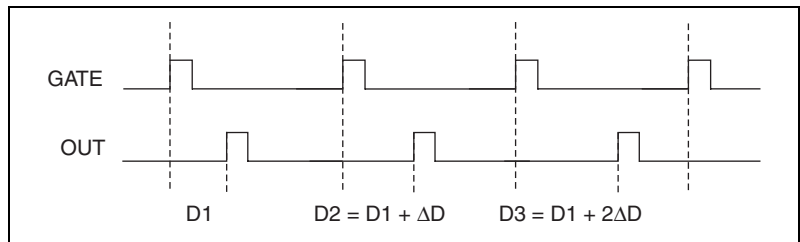

Figure 9-28. Pulse Generation for ETS

For information about connecting counter signals, refer to the [Default Counter/Timer Pinouts](#) section.

Counter Timing Signals

USB M Series devices feature the following counter timing signals.

- Counter n Source
- Counter n Gate
- Counter n Aux
- Counter n A
- Counter n B
- Counter n Z
- Counter n Up_Down
- Counter n HW Arm
- Counter n Internal Output
- Counter n TC
- Frequency Output

In this section, n refers to either Counter 0 or 1. For example, Counter n Source refers to two signals—Counter 0 Source (the source input to Counter 0) and Counter 1 Source (the source input to Counter 1).

Counter n Source Signal

The selected edge of the Counter n Source signal increments and decrements the counter value depending on the application the counter is performing. Table 9-4 lists how this terminal is used in various applications.

Table 9-4. Counter Applications and Counter n Source

Application	Purpose of Source Terminal
Pulse Generation	Counter Timebase
One Counter Time Measurements	Counter Timebase
Two Counter Time Measurements	Input Terminal
Non-Buffered Edge Counting	Input Terminal
Buffered Edge Counting	Input Terminal
Two-Edge Separation	Counter Timebase

Routing a Signal to Counter n Source

Each counter has independent input selectors for the Counter n Source signal. Any of the following signals can be routed to the Counter n Source input.

- 80 MHz Timebase
- 20 MHz Timebase
- 100 kHz Timebase
- PFI <0..3>, PFI <8..11>

In addition, Counter 1 TC or Counter 1 Gate can be routed to Counter 0 Source. Counter 0 TC or Counter 0 Gate can be routed to Counter 1 Source.

Some of these options may not be available in some driver software.

Routing Counter n Source to an Output Terminal

You can route Counter n Source out to any PFI <4..7> or PFII <12..15> terminal.

Counter n Gate Signal

The Counter n Gate signal can perform many different operations depending on the application including starting and stopping the counter, and saving the counter contents.

Routing a Signal to Counter n Gate

Each counter has independent input selectors for the Counter n Gate signal. Any of the following signals can be routed to the Counter n Gate input.

- PFI <0..3>, PFI <8..11>
- ai/ReferenceTrigger
- ai/StartTrigger
- ai/SampleClock
- ai/ConvertClock
- ao/SampleClock

In addition, Counter 1 Internal Output or Counter 1 Source can be routed to Counter 0 Gate. Counter 0 Internal Output or Counter 0 Source can be routed to Counter 1 Gate.

Some of these options may not be available in some driver software.

Routing Counter n Gate to an Output Terminal

You can route Counter n Gate out to any PFI <4..7> or PFI <12..15> terminal.

Counter n Aux Signal

The Counter n Aux signal indicates the first edge in a two-signal edge-separation measurement.

Routing a Signal to Counter n Aux

Each counter has independent input selectors for the Counter n Aux signal. Any of the following signals can be routed to the Counter n Aux input.

- PFI <0..3>, PFI <8..11>
- ai/ReferenceTrigger
- ai/StartTrigger

In addition, Counter 1 Internal Output, Counter 1 Gate, Counter 1 Source, or Counter 0 Gate can be routed to Counter 0 Aux. Counter 0 Internal

Output, Counter 0 Gate, Counter 0 Source, or Counter 1 Gate can be routed to Counter 1 Aux.

Some of these options may not be available in some driver software.

Counter n A, Counter n B, and Counter n Z Signals

Counter n B can control the direction of counting in edge counting applications. Use the A, B, and Z inputs to each counter when measuring quadrature encoders or measuring two pulse encoders.

Routing Signals to A, B, and Z Counter Inputs

Each counter has independent input selectors for each of the A, B, and Z inputs. The PFI <0..3> or PFI <8..11> signals can be routed to each input.

Counter n Up_Down Signal

Counter n Up_Down is another name for the Counter n B signal.

Counter n HW Arm Signal

The Counter n HW Arm signal enables a counter to begin an input or output function.

To begin any counter input or output function, you must first enable, or arm, the counter. In some applications, such as buffered semi-period measurement, the counter begins counting when it is armed. In other applications, such as single pulse-width measurement, the counter begins waiting for the Gate signal when it is armed. Counter output operations can use the arm signal in addition to a start trigger.

Software can arm counters or configure counters to be armed on the assertion of the Counter n HW Arm signal.

Routing Signals to Counter n HW Arm Input

Any of the following signals can be routed to the Counter n HW Arm input.

- PFI <0..3>, PFI <8..11>
- ai/ReferenceTrigger
- ai/StartTrigger

Counter 1 Internal Output can be routed to Counter 0 HW Arm.
Counter 0 Internal Output can be routed to Counter 1 HW Arm.

Some of these options may not be available in some driver software.

Counter *n* Internal Output and Counter *n* TC Signals

Counter *n* TC is an internal signal that asserts when the counter value is 0.

The Counter *n* Internal Output signal changes in response to Counter *n* TC. The two software-selectable output options are pulse on TC and toggle output polarity on TC. The output polarity is software-selectable for both options.

Routing Counter *n* Internal Output to an Output Terminal

You can route Counter *n* Internal Output to any PFI <4..7> or PFI <12..15> terminal.

Frequency Output Signal

The Frequency Output (FREQ OUT) signal is the output of the frequency output generator.

Routing Frequency Output to a Terminal

You can route Frequency Output to any PFI <4..7> or PFI <12..15> terminal.

Default Counter/Timer Pinouts

By default, NI-DAQmx routes the counter/timer inputs and outputs to the PFI pins, shown in Tables 9-5 and 9-6.

Table 9-5. Default NI-DAQmx Counter/Timer Pins for USB-6210/6211/6215 Devices

Counter/Timer Signal	Default Terminal Number (Name)
CTR 0 SRC	1 (PFI 0)
CTR 0 GATE	2 (PFI 1)
CTR 0 AUX	1 (PFI 0)
CTR 0 OUT	6 (PFI 4)
CTR 0 A	1 (PFI 0)
CTR 0 Z	3 (PFI 2)

Table 9-5. Default NI-DAQmx Counter/Timer Pins for USB-6210/6211/6215 Devices (Continued)

Counter/Timer Signal	Default Terminal Number (Name)
CTR 0 B	2 (PFI 1)
CTR 1 SRC	4 (PFI 3)
CTR 1 GATE	3 (PFI 2)
CTR 1 AUX	4 (PFI 3)
CTR 1 OUT	7 (PFI 5)
CTR 1 A	4 (PFI 3)
CTR 1 Z	2 (PFI 1)
CTR 1 B	3 (PFI 2)
FREQ OUT	8 (PFI 6)

Table 9-6. Default NI-DAQmx Counter/Timer Pins for USB-6218 Devices

Counter/Timer Signal	Default Terminal Number (Name)
CTR 0 SRC	1 (PFI 0)
CTR 0 GATE	2 (PFI 1)
CTR 0 AUX	34 (PFI 9)
CTR 0 OUT	6 (PFI 4)
CTR 0 A	1 (PFI 0)
CTR 0 Z	2 (PFI 1)
CTR 0 B	34 (PFI 9)
CTR 1 SRC	4 (PFI 3)
CTR 1 GATE	3 (PFI 2)
CTR 1 AUX	35 (PFI 10)
CTR 1 OUT	7 (PFI 5)
CTR 1 A	4 (PFI 3)
CTR 1 Z	3 (PFI 2)
CTR 1 B	35 (PFI 10)
FREQ OUT	8 (PFI 6)

You can use these defaults or select other sources and destinations for the counter/timer signals in NI-DAQmx. Refer to *Connecting Counter Signals* in the *NI-DAQmx Help* or the *LabVIEW 8.x Help* for more information about how to connect your signals for common counter measurements and generations. M Series default PFI lines for counter functions are listed in *Physical Channels* in the *NI-DAQmx Help* or the *LabVIEW 8.x Help*.

Counter Triggering

Counters support three different triggering actions—arm start, start, and pause.

Arm Start Trigger

Any counter operation can use the arm start trigger.

For counter output operations, you can use it in addition to the start and pause triggers. For counter input operations, you can use the arm start trigger to have start trigger-like behavior. The arm start trigger can be used for synchronizing multiple counter input and output tasks.

When using an arm start trigger, the arm start trigger source is routed to the Counter n HW Arm signal.

Start Trigger

For counter output operations, a start trigger can be configured to begin a finite or continuous pulse generation. Once a continuous generation has triggered, the pulses continue to generate until you stop the operation in software. For finite generations, the specified number of pulses is generated and the generation stops unless you use the retriggerable attribute. When you use this attribute, subsequent start triggers cause the generation to restart.

When using a start trigger, the start trigger source is routed to the Counter n Gate signal input of the counter.

Counter input operations can use the arm start trigger to have start trigger-like behavior.

Pause Trigger

You can use pause triggers in edge counting and continuous pulse generation applications. For edge counting acquisitions, the counter stops counting edges while the external trigger signal is low and resumes when

the signal goes high or vice versa. For continuous pulse generations, the counter stops generating pulses while the external trigger signal is low and resumes when the signal goes high or vice versa.

When using a pause trigger, the pause trigger source is routed to the Counter n Gate signal input of the counter.

Other Counter Features

Sample Clock

When taking counter measurements, you can enable a sample clock. When you use a sample clock, measurements are saved after an active edge of the sample clock. Figure 9-29 shows an example of using a sample clock with a buffered period measurement. In this example, a period is defined by two consecutive rising edges of the Gate.

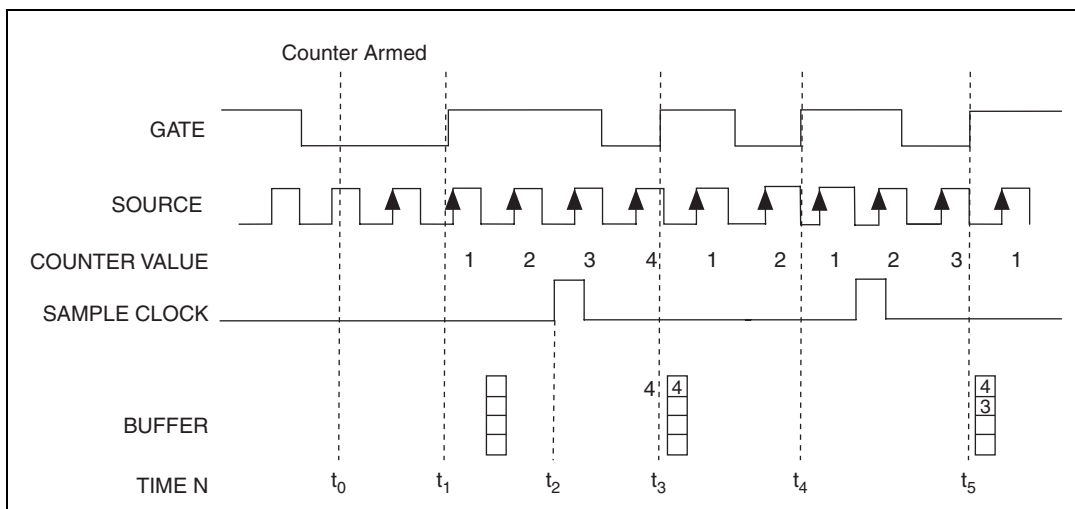

Figure 9-29. Sample Clock Example

Table 9-7. Time N Descriptions

t_0	At t_0 , the counter is armed. No measurements are taken until the counter is armed.
t_1	The rising edge of Gate indicates the beginning of the first period to measure. The counter begins counting rising edges of Source.
t_2	The rising edge of the Sample Clock indicates that the USB M Series device should store the result of the measurement of the current period when the period ends.
t_3	The rising edge of Gate indicates the end of the first period. The USB M Series device stores the counter value in the buffer.
t_4	The rising edge of Gate indicates the end of the second period. Sample Clock did not assert during this period, so the counter discards the measurement of the second period.
t_5	The rising edge of Gate indicates the end of the third period. Sample Clock asserts during this period, so the USB M Series device stores the measurement in the buffer.

Cascading Counters

You can internally route the Counter n Internal Output and Counter n TC signals of each counter to Gate inputs of the other counter. By cascading two counters together, you can effectively create a 64-bit counter. By cascading counters, you also can enable other applications. For example, to improve the accuracy of frequency measurements, use reciprocal frequency measurement, as described in the [Method 3—Measure Large Range of Frequencies Using Two Counters](#) section.

Counter Filters

You can enable a programmable debouncing filter on each PFI signal. When the filters are enabled, your device samples the input on each rising edge of a filter clock. M Series devices use an onboard oscillator to generate the filter clock with a 40 MHz frequency.



Note NI-DAQmx *only* supports filters on counter inputs.

The following is an example of low to high transitions of the input signal. High to low transitions work similarly.

Assume that an input terminal has been low for a long time. The input terminal then changes from low to high, but glitches several times. When the filter clock has sampled the signal high on N consecutive edges, the low to high transition is propagated to the rest of the circuit. The value of N depends on the filter setting; refer to Table 9-8.

Table 9-8. Filters

Filter Setting	N (Filter Clocks Needed to Pass Signal)	Pulse Width Guaranteed to Pass Filter	Pulse Width Guaranteed to Not Pass Filter
125 ns	5	125 ns	100 ns
6.425 μ s	257	6.425 μ s	6.400 μ s
2.55 ms	~101,800	2.55 ms	2.54 ms
Disabled	—	—	—

The filter setting for each input can be configured independently. On power up, the filters are disabled. Figure 9-30 shows an example of a low to high transition on an input that has its filter set to 125 ns ($N = 5$).

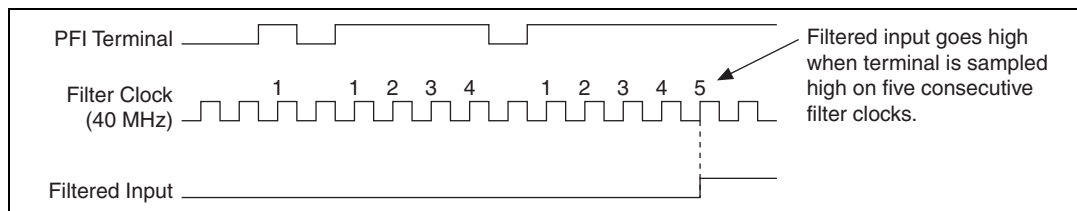
**Figure 9-30.** Filter Example

Enabling filters introduces jitter on the input signal. For the 125 ns and 6.425 μ s filter settings, the jitter is up to 25 ns. On the 2.55 ms setting, the jitter is up to 10.025 μ s.

Refer to the KnowledgeBase document, *Digital Filtering with M Series*, for more information about digital filters and counters. To access this KnowledgeBase, go to ni.com/info and enter the info code `rddfms`.

Prescaling

Prescaling allows the counter to count a signal that is faster than the maximum timebase of the counter. M Series devices offer 8X and 2X prescaling on each counter (prescaling can be disabled). Each prescaler consists of a small, simple counter that counts to eight (or two) and rolls over. This counter can run faster than the larger counters, which simply count the rollovers of this smaller counter. Thus, the prescaler acts as a frequency divider on the Source and puts out a frequency that is one-eighth (or one-half) of what it is accepting.

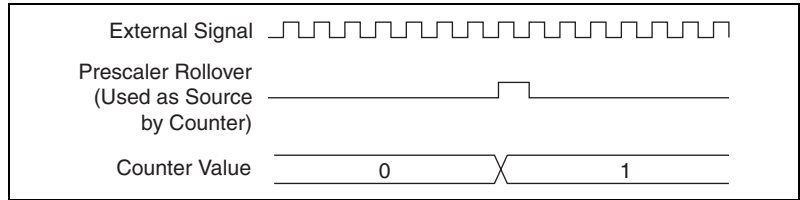

Figure 9-31. Prescaling

Prescaling is intended to be used for frequency measurement where the measurement is made on a continuous, repetitive signal. The prescaling counter cannot be read; therefore, you cannot determine how many edges have occurred since the previous rollover. Prescaling can be used for event counting provided it is acceptable to have an error of up to seven (or one). Prescaling can be used when the counter Source is an external signal. Prescaling is not available if the counter Source is one of the internal timebases (80MHzTimebase, 20MHzTimebase, or 100kHzTimebase).

Duplicate Count Prevention

Duplicate count prevention (or synchronous counting mode) is used when taking frequency or period measurements on USB-621x devices, which ensures that a counter returns correct data in applications that use a slow or non-periodic external source. Duplicate count prevention applies only to buffered counter applications such as measuring frequency or period. In such buffered applications, the counter should store the number of times an external Source pulses between rising edges on the Gate signal.

Example Application That Works Correctly (No Duplicate Counting)

Figure 9-32 shows an external buffered signal as the period measurement Source.

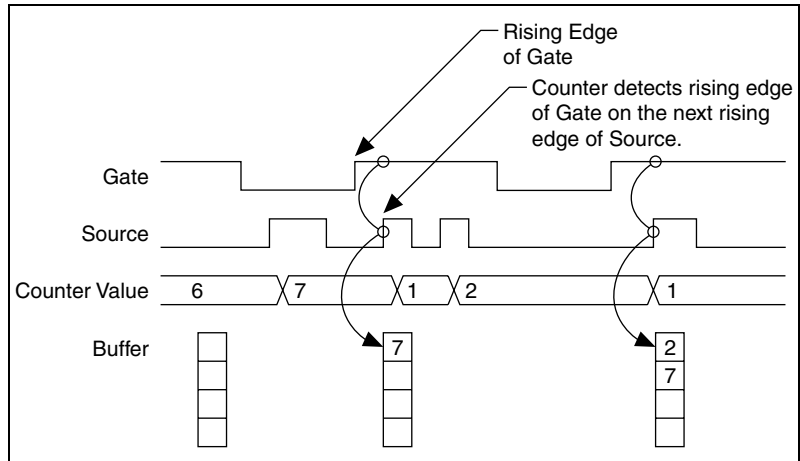

Figure 9-32. Duplicate Count Prevention Example

On the first rising edge of Gate, the current count of 7 is stored. On the next rising edge of Gate, the counter stores a 2 since two Source pulses occurred after the previous rising edge of Gate.

The counter synchronizes or samples the Gate signal with the Source signal, so the counter does not detect a rising edge in Gate until the next Source pulse. In this example, the counter stores the values in the buffer on the first rising Source edge after the rising edge of Gate. The details of when exactly the counter synchronizes the Gate signal vary depending on the synchronization mode.

Example Application That Works Incorrectly (Duplicate Counting)

In Figure 9-33, after the first rising edge of Gate, no Source pulses occur, so the counter does not write the correct data to the buffer.

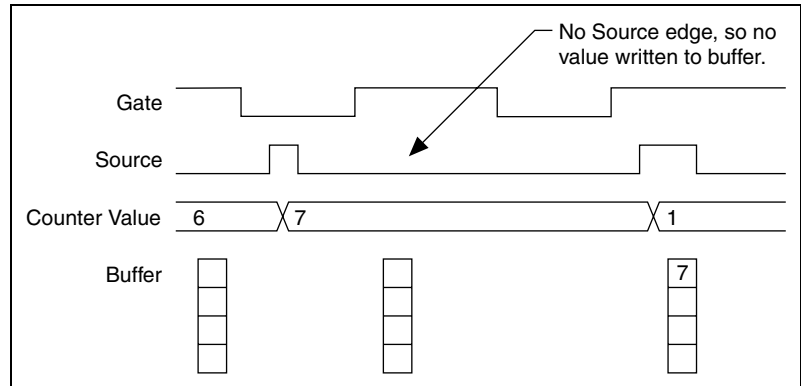

Figure 9-33. Duplicate Count Example

Example Application That Prevents Duplicate Count

With duplicate count prevention, the counter synchronizes both the Source and Gate signals to the 80 MHz Timebase. By synchronizing to the timebase, the counter detects edges on Gate even if the Source does not pulse. This enables the correct current count to be stored in the buffer even if no Source edges occur between Gate signals, as shown in Figure 9-34.

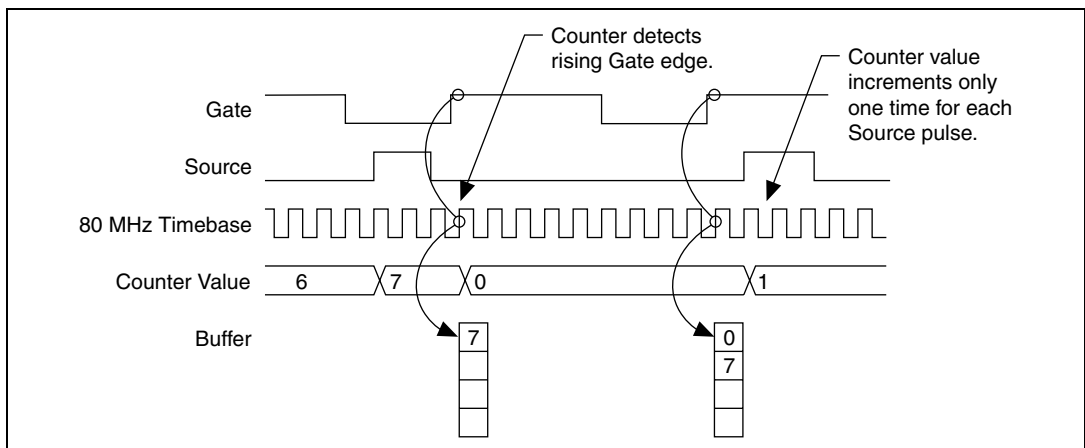

Figure 9-34. Duplicate Count Prevention Example

Even if the Source pulses are long, the counter increments only once for each Source pulse.

Normally, the counter value and Counter n Internal Output signals change synchronously to the Source signal. With duplicate count prevention, the counter value and Counter n Internal Output signals change synchronously to the 80 MHz Timebase.

Enabling Duplicate Count Prevention in NI-DAQmx

Duplicate count prevention is automatically used with the USB-621x devices. Disabling duplicate count prevention is not supported.

PFI

NI 621x devices have up to eight input and eight output Programmable Function Interface (PFI) signals, which also can be used as static digital input or static digital output signals.

Each input PFI can be individually configured as the following:

- A static digital input
- A timing input signal for AI, AO, or counter/timer functions

Each output PFI can be individually configured as the following:

- A static digital output
- A timing output signal from AI, AO, or counter/timer functions

Each PFI input also has a programmable debouncing filter. Figure 10-1 shows the circuitry of an input PFI line.

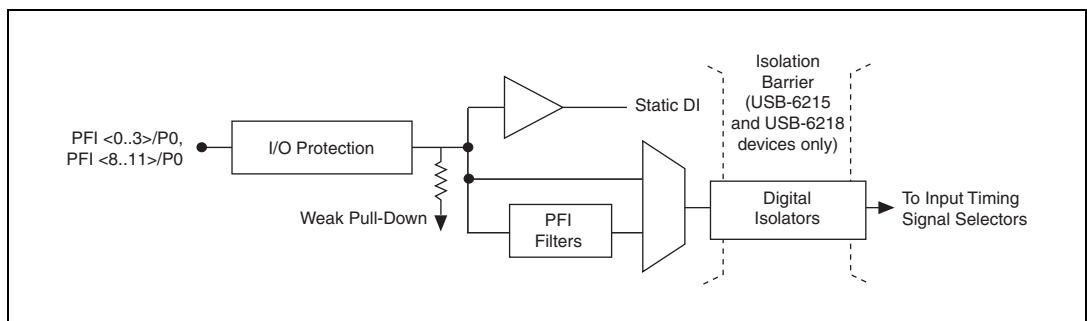

Figure 10-1. NI 621x PFI Input Circuitry

Figure 10-2 shows the circuitry of an output PFI line.

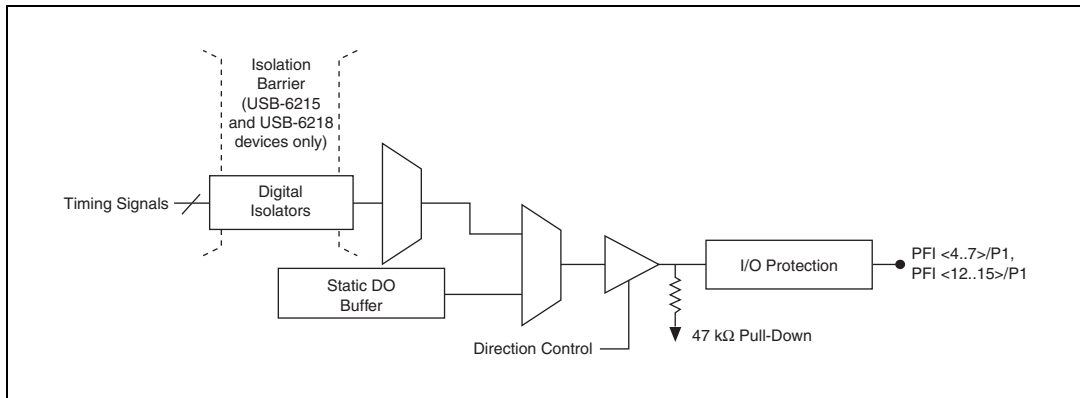

Figure 10-2. NI 621x PFI Output Circuitry

When a terminal is used as a timing input or output signal, it is called PFI x . When a terminal is used as a static digital input or output, it is called PO. x or P1. x . On the I/O connector, each terminal is labeled PFI x /P0 or PFI x /P1.

The voltage input and output levels and the current drive levels of the PFI signals are listed in the specifications of your device.

Using PFI Terminals as Timing Input Signals

Use PFI terminals to route external timing signals to many different M Series functions. Each input PFI terminal can be routed to any of the following signals.

- AI Convert Clock
- AI Sample Clock
- AI Start Trigger
- AI Reference Trigger
- AI Pause Trigger
- AI Sample Clock Timebase
- AO Start Trigger
- AO Sample Clock
- AO Sample Clock Timebase
- AO Pause Trigger
- Counter input signals for either counter—Source, Gate, Aux, HW_Arm, A, B, Z

Most functions allow you to configure the polarity of PFI inputs and whether the input is edge or level sensitive.

Exporting Timing Output Signals Using PFI Terminals

You can route any of the following timing signals to any PFI output terminal.

- AI Convert Clock*
- AI Hold Complete Event
- AI Reference Trigger
- AI Sample Clock
- AI Start Trigger
- AO Sample Clock*
- AO Start Trigger
- Counter n Source
- Counter n Gate
- Counter n Internal Output
- Frequency Output



Note Signals with a * are inverted before being driven to a terminal; that is, these signals are active low.

Using PFI Terminals as Static Digital I/Os

Each input PFI line can be individually configured as a static digital input, called P0. x . Each output PFI line can be individually configured as a static digital output, called P1. x .

Connecting PFI Input Signals

All PFI input connections are referenced to D GND. Figure 10-3 shows this reference, and how to connect an external PFI 0 source and an external PFI 2 source to two PFI terminals.

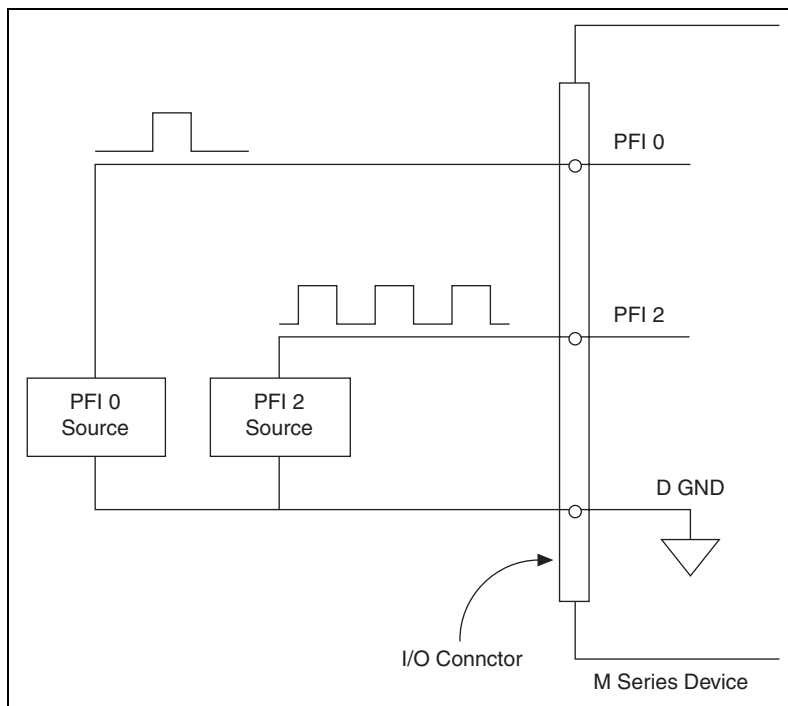

Figure 10-3. PFI Input Signals Connections

PFI Filters

You can enable a programmable debouncing filter on each PFI signal. When the filters are enabled, your device samples the input on each rising edge of a filter clock. M Series devices use an onboard oscillator to generate the filter clock with a 40 MHz frequency.



Note NI-DAQmx *only* supports filters on counter inputs.

The following is an example of low to high transitions of the input signal. High to low transitions work similarly.

Assume that an input terminal has been low for a long time. The input terminal then changes from low to high, but glitches several times. When the filter clock has sampled the signal high on N consecutive edges, the low to high transition is propagated to the rest of the circuit. The value of N depends on the filter setting; refer to Table 10-1.

Table 10-1. Filters

Filter Setting	N (Filter Clocks Needed to Pass Signal)	Pulse Width Guaranteed to Pass Filter	Pulse Width Guaranteed to Not Pass Filter
125 ns	5	125 ns	100 ns
6.425 μ s	257	6.425 μ s	6.400 μ s
2.55 ms	~101,800	2.55 ms	2.54 ms
Disabled	—	—	—

The filter setting for each input can be configured independently. On power up, the filters are disabled. Figure 10-4 shows an example of a low to high transition on an input that has its filter set to 125 ns ($N = 5$).

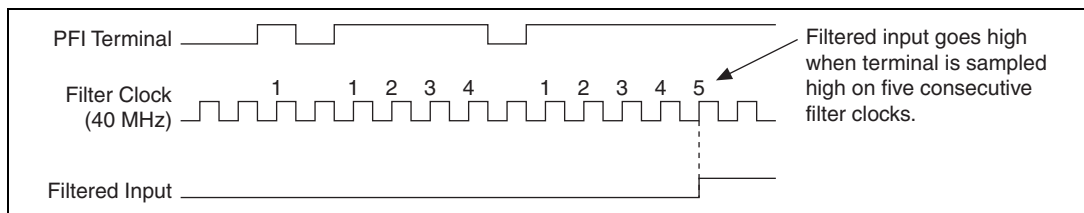
**Figure 10-4.** Filter Example

Enabling filters introduces jitter on the input signal. For the 125 ns and 6.425 μ s filter settings, the jitter is up to 25 ns. On the 2.55 ms setting, the jitter is up to 10.025 μ s.

When a PFI input is routed directly to RTSI, or a RTSI input is routed directly to PFI, the M Series device does not use the filtered version of the input signal.

Refer to the KnowledgeBase document, *Digital Filtering with M Series*, for more information about digital filters and counters. To access this KnowledgeBase, go to ni.com/info and enter the info code `rddfms`.

I/O Protection

Each DI, DO, and PFI signal is protected against overvoltage, undervoltage, and overcurrent conditions as well as ESD events. However, you should avoid these fault conditions by following these guidelines.

- Do *not* connect a DO or PFI output lines to any external signal source, ground signal, or power supply.
- Understand the current requirements of the load connected to DO or PFI output signals. Do not exceed the specified current output limits of the DAQ device. NI has several signal conditioning solutions for digital applications requiring high current drive.
- Do *not* drive a DI or PFI input line with voltages outside of its normal operating range. The PFI or DI lines have a smaller operating range than the AI signals.
- Treat the DAQ device as you would treat any static sensitive device. Always properly ground yourself and the equipment when handling the DAQ device or connecting to it.

Programmable Power-Up States

At system startup and reset, the hardware sets all output PFI and DO lines to high-impedance by default. The DAQ device does not drive the signal high or low. Each line has a weak pull-down resistor connected to it, as described in the specifications document for your device.

NI-DAQmx 8.3 and later supports programmable power-up states for PFI and DIO lines. Software can program any value at power up to the P1 lines. The output PFI and DO lines can be set as:



- A high-impedance input with a weak pull-down resistor (default)
- An output driving a 0
- An output driving a 1

Refer to the *NI-DAQmx Help* or the *LabVIEW 8.x Help* for more information about setting power-up states in NI-DAQmx or MAX.

Isolation and Digital Isolators

USB-6215/6218 devices are isolated data acquisition devices. As shown in Figure 11-1, the analog input, analog output, counters, PFI/static DI, and PFI/static DO circuitry, and digital routing and clock generation are referenced to an *isolated ground*. The bus interface circuitry is referenced to a *non-isolated ground*. Refer to Table 11-1 for an example of the symbols for isolated ground and non-isolated ground.

Table 11-1. Ground Symbols

	
Isolated Ground	Non-Isolated Ground

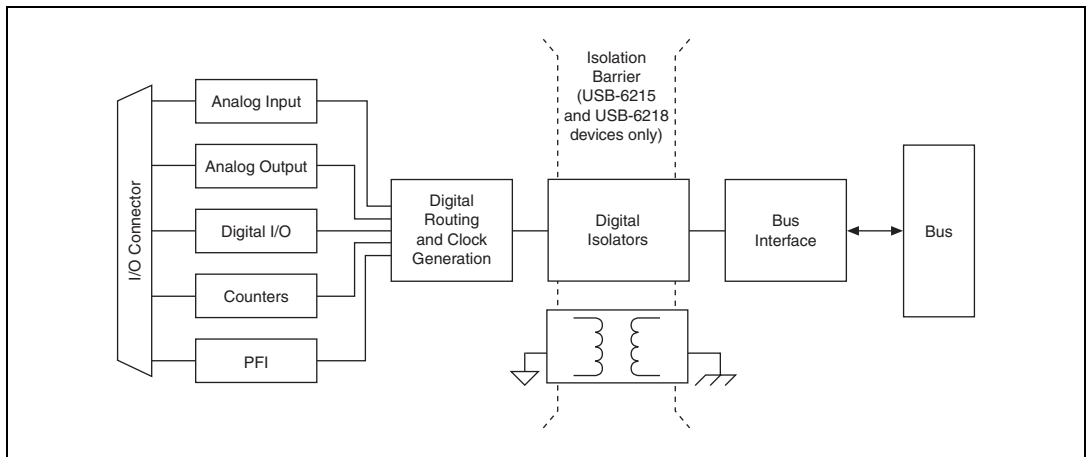

Figure 11-1. General NI 621x Block Diagram

The non-isolated ground is connected to the chassis ground of the PC.

Each isolated ground is *not* connected to the chassis ground of the PC. The isolated ground can be at a higher or lower voltage relative to the non-isolated ground. All analog measurements are made relative to the isolated ground signal.

The isolated ground is an *input* to the USB-6215/6218 device. The user *must* connect this ground to the ground of system being measured or controlled. Refer to Chapter 5, [Connecting AI Signals on the USB-6210/6211 Devices](#), Chapter 6, [Connecting AI Signals on the USB-6215/6218 Devices](#), the [Connecting Analog Output Signals](#) section of Chapter 7, [Analog Output](#), the [Connecting Digital I/O Signals](#) section of Chapter 8, [Digital I/O](#), and the [Connecting PFI Input Signals](#) section of Chapter 10, [PFI](#), for more information.

Digital Isolation

The USB-6215/6218 uses digital isolators. Unlike analog isolators, digital isolators do not introduce any analog error in the measurements taken by the device. The A/D converter, used for analog input, is on the isolated side of the device. The analog inputs are digitized before they are sent across the isolation barrier. Similarly, the D/A converters, used for analog output, are on the isolated side of the device.

Benefits of an Isolated DAQ Device

With isolation, engineers can safely measure a small signal in the presence of a large common-mode voltage signal. Some advantages of isolation are as follows:

- **Improved rejection**—Isolation increases the ability of the measurement system to reject common-mode voltages. *Common-mode voltage* is the signal that is present or “common” to both the positive and negative input of a measurement device, but is not part of the signal to be measured.
- **Improved accuracy**—Isolation improves measurement accuracy by physically preventing ground loops. Ground loops, a common source of error and noise, are the result of a measurement system having multiple grounds at different potentials.
- **Improved safety**—Isolation creates an insulation barrier so you can make floating measurements while protecting the USB host computer against large transient voltage spikes.

Reducing Common-Mode Noise

Isolated products require an isolated power supply to deliver power to the isolated side from the non-isolated side. Isolated power supplies work by switching voltages through a transformer with high-speed transistors.

Switching voltages through the transformer cause charging and discharging of the parasitic capacitances and inductances in the switching power supplies that occur on every switch cycle, resulting in high-speed currents flowing through the isolated side and returning to the non-isolated side, which is earth ground.

These parasitic currents interact with parasitic and non-parasitic resistances causing voltage spikes. These voltage spikes are called *common-mode noise*, a noise source that travels in the ground and is therefore common to both the ground and any signal referenced to the ground, such as AI, AO, and digital signals. Common-mode noise appears at the harmonics of the switching power supply frequency and can corrupt measurements depending on the system setup.

To reduce common-mode noise:

- Better grounding from the front connector AI GND to the signal source ground can reduce common-mode noise. Use low resistance cabling and connections and verify that all ground connections are kept short. Keep the number of connections to a minimum. If the device's isolated ground is being connected back to earth ground, verify that this is done in the most direct way possible.
- Reduce source impedances if possible. The parasitic currents react with these impedances.

Creating an AC Return Path



Caution Adding a capacitor will degrade the USB M Series device withstand voltage and isolation specifications. Withstand voltage *must* be retested by an approved testing facility after adjustments are made to the measurement system.

Isolated Systems

A fully isolated measurement system is one where the device's isolated front end is not connected back to earth ground.

Create an AC path back to earth ground from the device's isolated ground by connecting a high voltage capacitor between the isolated board ground and earth ground. The voltage rating of the capacitor must be larger than the voltage drop between the isolated ground and earth ground.

Non-Isolated Systems

A non-isolated measurement system is one where the device's isolated front end connects to earth ground.

Add an AC return path from the device isolated ground to earth ground. For non-isolated systems, an AC return path is only needed for high or source impedances. An AC return path can be created by connecting a capacitor between the device's isolated ground and earth ground.

Digital Routing and Clock Generation

The digital routing circuitry has the following main functions.

- Manages the flow of data between the bus interface and the acquisition/generation sub-systems (analog input, analog output, digital I/O, and the counters). The digital routing circuitry uses FIFOs (if present) in each sub-system to ensure efficient data movement.
- Routes timing and control signals. The acquisition/generation sub-systems use these signals to manage acquisitions and generations. These signals can come from the following sources.
 - Your M Series device
 - User input through the PFI terminals
- Routes and generates the main clock signals for the M Series device.

80 MHz Timebase

The 80 MHz Timebase can be used as the Source input to the 32-bit general-purpose counter/timers.

The 80 MHz Timebase is generated from the onboard oscillator.

20 MHz Timebase

The 20 MHz Timebase normally generates many of the AI and AO timing signals. The 20 MHz Timebase also can be used as the Source input to the 32-bit general-purpose counter/timers.

The 20 MHz Timebase is generated by dividing down the 80 MHz Timebase.

100 kHz Timebase

The 100 kHz Timebase can be used to generate many of the AI and AO timing signals. The 100 kHz Timebase also can be used as the Source input to the 32-bit general-purpose counter/timers.

The 100 kHz Timebase is generated by dividing down the 20 MHz Timebase by 200.

Bus Interface

The bus interface circuitry of M Series devices efficiently moves data between host memory and the measurement and acquisition circuits.

All M Series devices are jumperless for complete plug-and-play operation. The operating system automatically assigns the base address, interrupt levels, and other resources.

NI 621x devices incorporate USB-STC2 technology to implement a Hi-Speed USB interface.

USB Signal Streams

M Series USB devices have four fully-independent USB Signal Streams for high-performance transfers of data blocks. One USB Signal Stream is available for each measurement and acquisition block.

- Analog input
- Analog output
- Counter 0
- Counter 1

Data Transfer Methods

The two primary ways to transfer data across the USB bus are USB Signal Stream and programmed I/O.

USB Signal Stream

USB Signal Stream is a method to transfer data between the device and computer memory using USB bulk transfers without intervention of the microcontroller on the NI device. NI uses USB Signal Stream hardware and software technology to achieve high throughput rates and increase system utilization in USB devices.

Programmed I/O

Programmed I/O is a data transfer mechanism where the user's program is responsible for transferring data. Each read or write call in the program initiates the transfer of data. Programmed I/O is typically used in software-timed (on-demand) operations. Refer to the *Software-Timed Generations* section of Chapter 7, *Analog Output*, for more information.

Changing Data Transfer Methods

USB M Series devices have four dedicated USB Signal Stream channels. To change your data transfer mechanism between USB Signal Streams and programmed I/O, use the **Data Transfer Mechanism** property node function in NI-DAQmx.

Triggering

A *trigger* is a signal that causes an action, such as starting or stopping the acquisition of data. When you configure a trigger, you must decide how you want to produce the trigger and the action you want the trigger to cause. All M Series devices support internal software triggering, as well as external digital triggering. For information about the different actions triggers can perform for each sub-system of the device, refer to the following sections:

- The *Analog Input Digital Triggering* section of Chapter 4, *Analog Input*
- The *Analog Output Digital Triggering* section of Chapter 7, *Analog Output*
- The *Counter Triggering* section of Chapter 9, *Counters*

Triggering with a Digital Source

Your DAQ device can generate a trigger on a digital signal. You must specify a source and an edge. The digital source can be any input PFI signal.

The edge can be either the rising edge or falling edge of the digital signal. A rising edge is a transition from a low logic level to a high logic level. A falling edge is a high to low transition.

Figure 14-1 shows a falling-edge trigger.

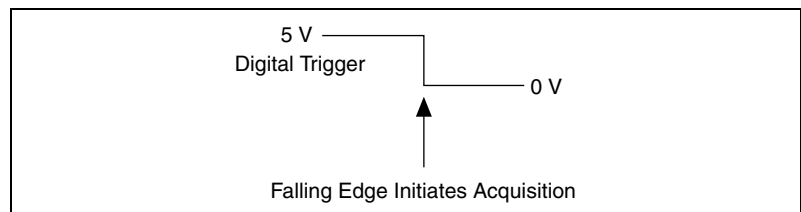

Figure 14-1. Falling-Edge Trigger

You also can program your DAQ device to perform an action in response to a trigger from a digital source. The action can affect the following:

- Analog input acquisition
- Analog output generation
- Counter behavior

Device-Specific Information

This appendix contains device pinouts, specifications, cable and accessory choices, and other information for the following USB M Series devices.

- USB-6210
- [USB-6211/6215](#)
- [USB 6218](#)

To obtain documentation for devices not listed here, refer to ni.com/manuals.

USB-6210

USB-6210 Pinout

Figure A-1 shows the pinout of the NI 6210.

For a detailed description of each signal, refer to the *I/O Connector Signal Descriptions* section of Chapter 3, *Connector Information*.

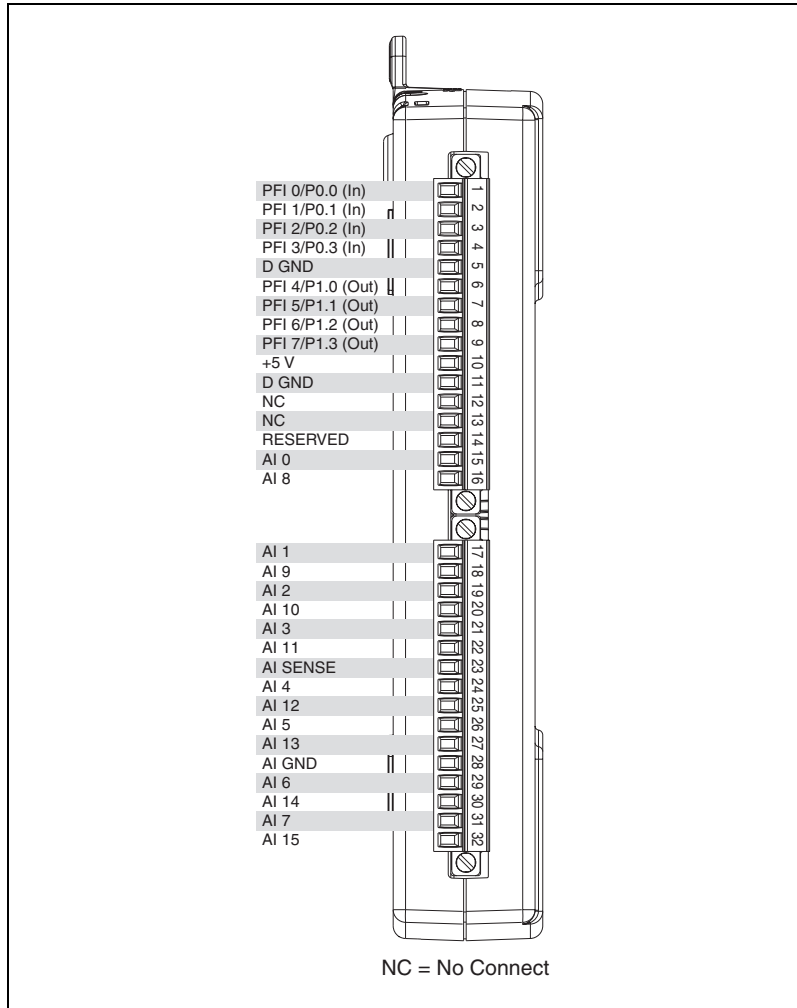

Figure A-1. USB-6210 Pinout

Table A-1. Default NI-DAQmx Counter/Timer Pins

Counter/Timer Signal	Default Terminal Number (Name)
CTR 0 SRC	1 (PFI 0)
CTR 0 GATE	2 (PFI 1)
CTR 0 AUX	1 (PFI 0)
CTR 0 OUT	6 (PFI 4)
CTR 0 A	1 (PFI 0)

Table A-1. Default NI-DAQmx Counter/Timer Pins (Continued)

Counter/Timer Signal	Default Terminal Number (Name)
CTR 0 Z	2 (PFI 1)
CTR 0 B	1 (PFI 0)
CTR 1 SRC	4 (PFI 3)
CTR 1 GATE	3 (PFI 2)
CTR 1 AUX	4 (PFI 3)
CTR 1 OUT	7 (PFI 5)
CTR 1 A	4 (PFI 3)
CTR 1 Z	3 (PFI 2)
CTR 1 B	4 (PFI 3)
FREQ OUT	8 (PFI 6)



Note For more information about default NI-DAQmx counter inputs, refer to *Connecting Counter Signals* in the *NI-DAQmx Help* or the *LabVIEW 8.x Help*.

USB-6210 Specifications

Refer to the *NI 621x Specifications* for more detailed information about the USB-6210 device.

USB-6210 PWR/ACT LED Indicator

The PWR/ACT LED indicator indicates device status.

Table A-2. PWR/ACT LED Status

LED State	Device Status
Not lit	Device not powered or device error. Refer to ni.com/support if device is powered.
On, not blinking	Device error. Refer to ni.com/support .

Table A-2. PWR/ACT LED Status (Continued)

LED State	Device Status
Single-blink	Operating normally. Connected to USB Hi-Speed port. Refer to the <i>NI 621x Specifications</i> for more information.
Double-blink	Connected to USB full speed port. Device performance might be affected. Refer to the <i>NI 621x Specifications</i> for more information.

USB-6211/6215

USB-6211/6215 Pinout

Figure A-2 shows the pinout of the NI 6211/6215.

For a detailed description of each signal, refer to the *I/O Connector Signal Descriptions* section of Chapter 3, *Connector Information*.

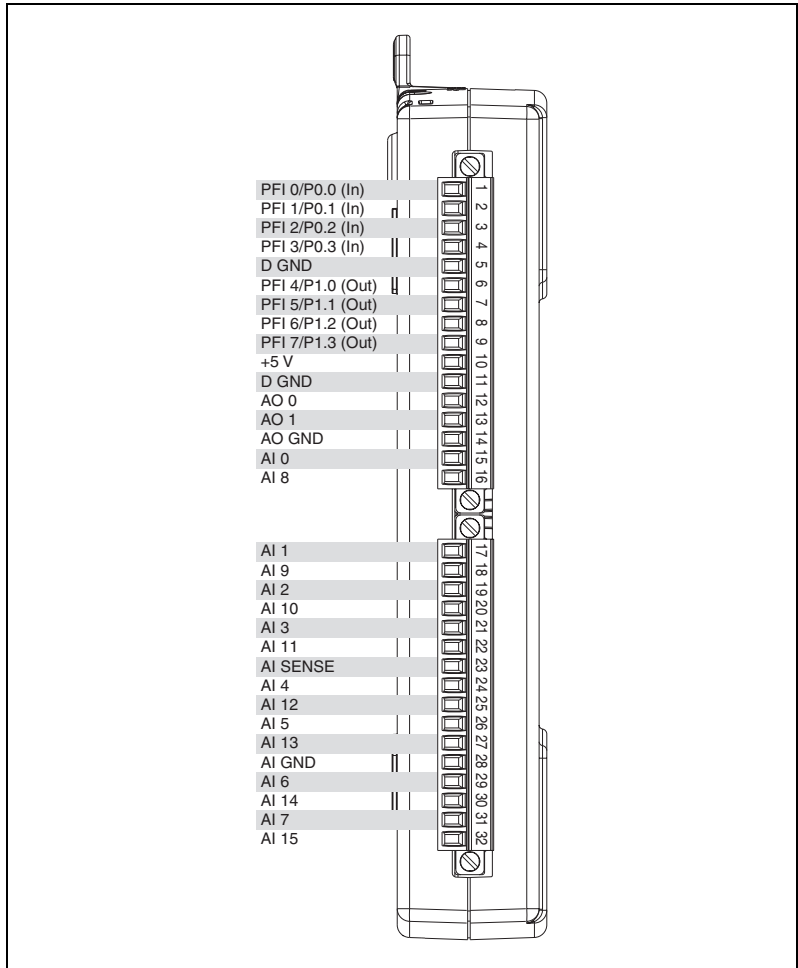

Figure A-2. USB-6211/6215 Pinout

Table A-3. Default NI-DAQmx Counter/Timer Pins

Counter/Timer Signal	Default Terminal Number (Name)
CTR 0 SRC	1 (PFI 0)
CTR 0 GATE	2 (PFI 1)
CTR 0 AUX	1 (PFI 0)
CTR 0 OUT	6 (PFI 4)
CTR 0 A	1 (PFI 0)
CTR 0 Z	2 (PFI 1)

Table A-3. Default NI-DAQmx Counter/Timer Pins (Continued)

Counter/Timer Signal	Default Terminal Number (Name)
CTR 0 B	1 (PFI 0)
CTR 1 SRC	4 (PFI 3)
CTR 1 GATE	3 (PFI 2)
CTR 1 AUX	4 (PFI 3)
CTR 1 OUT	7 (PFI 5)
CTR 1 A	4 (PFI 3)
CTR 1 Z	3 (PFI 2)
CTR 1 B	4 (PFI 3)
FREQ OUT	8 (PFI 6)



Note For more information about default NI-DAQmx counter inputs, refer to *Connecting Counter Signals* in the *NI-DAQmx Help* or the *LabVIEW 8.x Help*.

USB-6211/6215 Specifications

Refer to the *NI 621x Specifications* for more detailed information about the USB-6211/6215 device.

USB-6211/6215 PWR/ACT LED Indicator

The PWR/ACT LED indicator indicates device status.

Table A-4. PWR/ACT LED Status

LED State	Device Status
Not lit	Device not powered or device error. Refer to ni.com/support if device is powered.
On, not blinking	Device error. Refer to ni.com/support .

Table A-4. PWR/ACT LED Status (Continued)

LED State	Device Status
Single-blink	Operating normally. Connected to USB Hi-Speed port. Refer to the <i>NI 621x Specifications</i> for more information.
Double-blink	Connected to USB full speed port. Device performance might be affected. Refer to the <i>NI 621x Specifications</i> for more information.

USB 6218

USB 6218 Pinout

Figure A-3 shows the pinout of the NI 6218.

For a detailed description of each signal, refer to the *I/O Connector Signal Descriptions* section of Chapter 3, *Connector Information*.

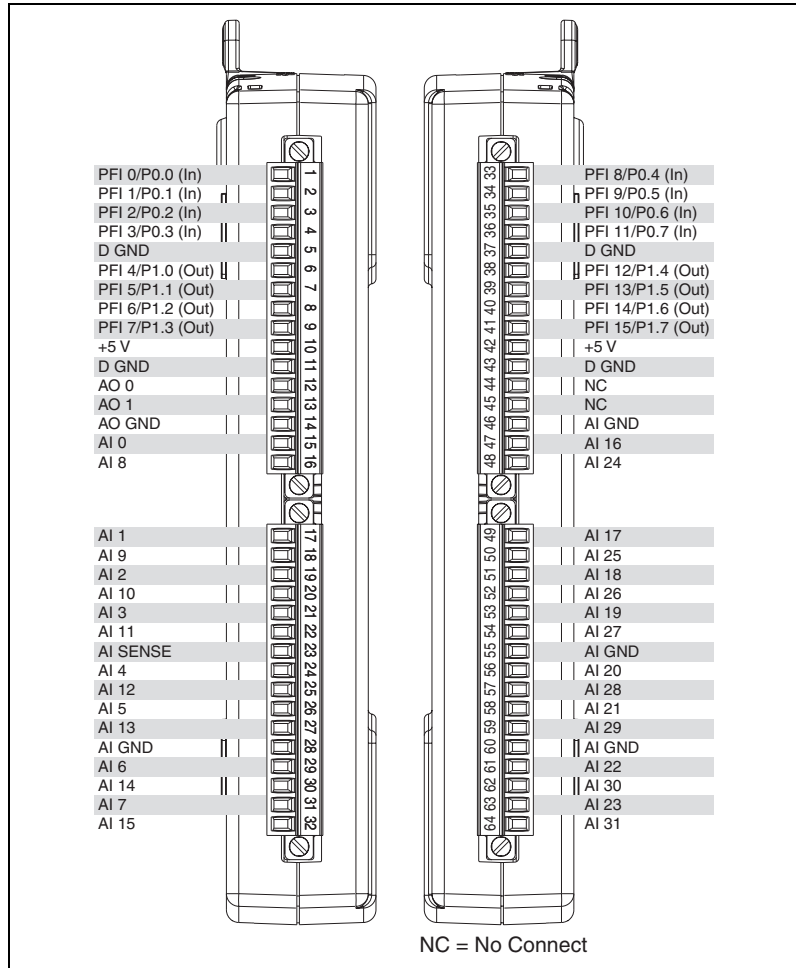

Figure A-3. USB 6218 Pinout

Table A-5. Default NI-DAQmx Counter/Timer Pins

Counter/Timer Signal	Default Terminal Number (Name)
CTR 0 SRC	1 (PFI 0)
CTR 0 GATE	2 (PFI 1)
CTR 0 AUX	34 (PFI 9)
CTR 0 OUT	6 (PFI 4)
CTR 0 A	1 (PFI 0)
CTR 0 Z	2 (PFI 1)

Table A-5. Default NI-DAQmx Counter/Timer Pins (Continued)

Counter/Timer Signal	Default Terminal Number (Name)
CTR 0 B	34 (PFI 9)
CTR 1 SRC	4 (PFI 3)
CTR 1 GATE	3 (PFI 2)
CTR 1 AUX	35 (PFI 10)
CTR 1 OUT	7 (PFI 5)
CTR 1 A	4 (PFI 3)
CTR 1 Z	3 (PFI 2)
CTR 1 B	35 (PFI 10)
FREQ OUT	8 (PFI 6)



Note For more information about default NI-DAQmx counter inputs, refer to *Connecting Counter Signals* in the *NI-DAQmx Help* or the *LabVIEW 8.x Help*.

USB 6218 Specifications

Refer to the *NI 621x Specifications* for more detailed information about the USB 6218 device.

USB 6218 PWR/ACT LED Indicator

The PWR/ACT LED indicator indicates device status.

Table A-6. PWR/ACT LED Status

LED State	Device Status
Not lit	Device not powered or device error. Refer to ni.com/support if device is powered.
On, not blinking	Device error. Refer to ni.com/support .

Table A-6. PWR/ACT LED Status (Continued)

LED State	Device Status
Single-blink	Operating normally. Connected to USB Hi-Speed port. Refer to the <i>NI 621x Specifications</i> for more information.
Double-blink	Connected to USB full speed port. Device performance might be affected. Refer to the <i>NI 621x Specifications</i> for more information.

Troubleshooting

This section contains common questions about M Series devices. If your questions are not answered here, refer to the National Instruments KnowledgeBase at ni.com/kb.

Analog Input

I am seeing crosstalk or ghost voltages when sampling multiple channels. What does this mean?

You may be experiencing a phenomenon called *charge injection*, which occurs when you sample a series of high-output impedance sources with a multiplexer. Multiplexers contain switches, usually made of switched capacitors. When a channel, for example AI 0, is selected in a multiplexer, those capacitors accumulate charge. When the next channel, for example AI 1, is selected, the accumulated current (or charge) leaks backward through channel 1. If the output impedance of the source connected to AI 1 is high enough, the resulting reading can somewhat affect the voltage in AI 0. To circumvent this problem, use a voltage follower that has operational amplifiers (op-amps) with unity gain for each high-impedance source before connecting to an M Series device. Otherwise, you must decrease the sample rate for each channel.

Another common cause of channel crosstalk is due to sampling among multiple channels at various gains. In this situation, the settling times can increase. For more information about charge injection and sampling channels at different gains, refer to the [Multichannel Scanning Considerations](#) section of Chapter 4, [Analog Input](#).

I am using my device in differential analog input ground-reference mode and I have connected a differential input signal, but my readings are random and drift rapidly. What is wrong?

In DIFF mode, if the readings from the DAQ device are random and drift rapidly, you should check the ground-reference connections. The signal can be referenced to a level that is considered floating with reference to the device ground reference. Even if you are in DIFF mode, you must still reference the signal to the same ground level as the device reference. There

are various methods of achieving this reference while maintaining a high common-mode rejection ratio (CMRR). These methods are outlined in Chapter 5, *Connecting AI Signals on the USB-6210/6211 Devices* and Chapter 6, *Connecting AI Signals on the USB-6215/6218 Devices*.

AI GND is an AI common signal that routes directly to the ground connection point on the devices. You can use this signal if you need a general analog ground connection point to the device. Refer to the *When to Use Differential Connections with Ground-Referenced Signal Sources* section of Chapter 5, *Connecting AI Signals on the USB-6210/6211 Devices*, for more information.

How can I use the AI Sample Clock and AI Convert Clock signals on an M Series device to sample the AI channel(s)?

M Series devices use ai/SampleClock and ai/ConvertClock to perform interval sampling. As Figure B-1 shows, ai/SampleClock controls the sample period, which is determined by the following equation:

$$1/\text{sample period} = \text{sample rate}$$

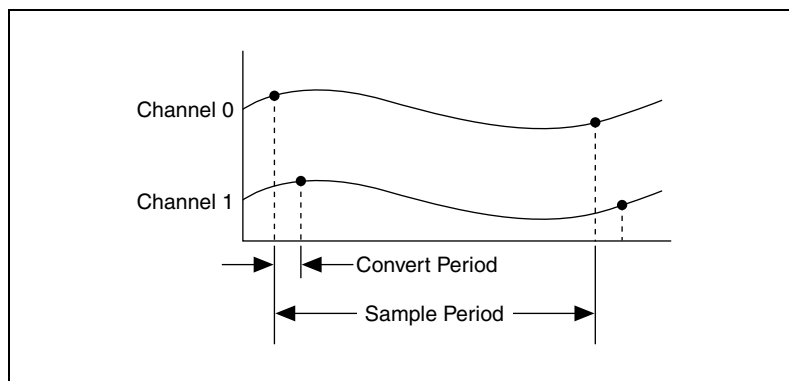

Figure B-1. ai/SampleClock and ai/ConvertClock

ai/ConvertClock controls the convert period, which is determined by the following equation:

$$1/\text{convert period} = \text{convert rate}$$

This method allows multiple channels to be sampled relatively quickly in relationship to the overall sample rate, providing a nearly simultaneous effect with a fixed delay between channels.

Analog Output

I am seeing glitches on the output signal. How can I minimize it?

When you use a DAC to generate a waveform, you may observe glitches on the output signal. These glitches are normal; when a DAC switches from one voltage to another, it produces glitches due to released charges. The largest glitches occur when the most significant bit of the DAC code changes. You can build a lowpass deglitching filter to remove some of these glitches, depending on the frequency and nature of the output signal. Visit ni.com/support for more information about minimizing glitches.



Technical Support and Professional Services

Visit the following sections of the National Instruments Web site at ni.com for technical support and professional services:

- **Support**—Online technical support resources at ni.com/support include the following:
 - **Self-Help Resources**—For answers and solutions, visit the award-winning National Instruments Web site for software drivers and updates, a searchable KnowledgeBase, product manuals, step-by-step troubleshooting wizards, thousands of example programs, tutorials, application notes, instrument drivers, and so on.
 - **Free Technical Support**—All registered users receive free Basic Service, which includes access to hundreds of Application Engineers worldwide in the NI Discussion Forums at ni.com/forums. National Instruments Application Engineers make sure every question receives an answer.

For information about other technical support options in your area, visit ni.com/services or contact your local office at ni.com/contact.

- **Training and Certification**—Visit ni.com/training for self-paced training, eLearning virtual classrooms, interactive CDs, and Certification program information. You also can register for instructor-led, hands-on courses at locations around the world.
- **System Integration**—If you have time constraints, limited in-house technical resources, or other project challenges, National Instruments Alliance Partner members can help. To learn more, call your local NI office or visit ni.com/alliance.
- **Declaration of Conformity (DoC)**—A DoC is our claim of compliance with the Council of the European Communities using the manufacturer's declaration of conformity. This system affords the user protection for electronic compatibility (EMC) and product safety. You can obtain the DoC for your product by visiting ni.com/certification.

- **Calibration Certificate**—If your product supports calibration, you can obtain the calibration certificate for your product at ni.com/calibration.

If you searched ni.com and could not find the answers you need, contact your local office or NI corporate headquarters. Phone numbers for our worldwide offices are listed at the front of this manual. You also can visit the Worldwide Offices section of ni.com/niglobal to access the branch office Web sites, which provide up-to-date contact information, support phone numbers, email addresses, and current events.

Glossary

Numbers/Symbols

%	Percent.
+	Positive of, or plus.
-	Negative of, or minus.
±	Plus or minus.
<	Less than.
>	Greater than.
≤	Less than or equal to.
≥	Greater than or equal to.
/	Per.
°	Degree.
Ω	Ohm.

A

A	Amperes—the unit of electric current.
A/D	Analog-to-Digital. Most often used as A/D converter.
AC	Alternating current.
accuracy	A measure of the capability of an instrument or sensor to faithfully indicate the value of the measured signal. This term is not related to resolution; however, the accuracy level can never be better than the resolution of the instrument.
ADE	Application development environment.

AI	<ol style="list-style-type: none">1. Analog input.2. Analog input channel signal.
AI GND	Analog input ground signal.
AI SENSE	Analog input sense signal.
analog	A signal whose amplitude can have a continuous range of values.
analog input signal	An input signal that varies smoothly over a continuous range of values, rather than in discrete steps.
analog output signal	An output signal that varies smoothly over a continuous range of values, rather than in discrete steps.
analog signal	A signal representing a variable that can be observed and represented continuously.
analog trigger	A trigger that occurs at a user-selected point on an incoming analog signal. Triggering can be set to occur at a specific level on either an increasing or a decreasing signal (positive or negative slope). Analog triggering can be implemented either in software or in hardware. When implemented in software (LabVIEW), all data is collected, transferred into system memory, and analyzed for the trigger condition. When analog triggering is implemented in hardware, no data is transferred to system memory until the trigger condition has occurred.
AO	Analog output.
AO 0	Analog channel 0 output signal.
AO 1	Analog channel 1 output signal.
AO 2	Analog channel 2 output signal.
AO 3	Analog channel 3 output signal.
AO GND	Analog output ground signal.
application	A software program that creates an end-user function.
arm	The process of getting an instrument ready to perform a function. For example, the trigger circuitry of a digitizer is armed, meaning that it is ready to start acquiring data when an appropriate trigger condition is met.

ASIC	Application-specific integrated circuit—A proprietary semiconductor component designed and manufactured to perform a set of specific functions for a specific customer.
asynchronous	<ol style="list-style-type: none"> 1. Hardware—A property of an event that occurs at an arbitrary time, without synchronization to a reference clock. 2. Software—A property of a function that begins an operation and returns prior to the completion or termination of the operation.
B	
b	Bit—One binary digit, either 0 or 1.
B	Byte—Eight related bits of data, an eight-bit binary number. Also used to denote the amount of memory required to store one byte of data.
block diagram	A pictorial description or representation of a program or algorithm.
BNC	Bayonet-Neill-Concelman—A type of coaxial connector used in situations requiring shielded cable for signal connections and/or controlled impedance applications.
buffer	<ol style="list-style-type: none"> 1. Temporary storage for acquired or generated data. 2. A memory device that stores intermediate data between two devices.
bus, buses	The group of electrical conductors that interconnect individual circuitry in a computer. Typically, a bus is the expansion vehicle to which I/O or other devices are connected. Examples of PC buses are the PCI, AT (ISA), and EISA bus.
C	
C	Celsius.
calibration	The process of determining the accuracy of an instrument. In a formal sense, calibration establishes the relationship of an instrument's measurement to the value provided by a standard. When that relationship is known, the instrument may then be adjusted (calibrated) for best accuracy.
calibrator	A precise, traceable signal source used to calibrate instruments.

cascading	Process of extending the counting range of a counter chip by connecting to the next higher counter.
CE	European emissions control standard.
channel	Pin or wire lead to which you apply or from which you read the analog or digital signal. Analog signals can be single-ended or differential. For digital signals, you group channels to form ports. Ports usually consist of either four or eight digital channels.
clock	Hardware component that controls timing for reading from or writing to groups.
CMOS	Complementary metal-oxide semiconductor.
CMRR	Common-mode rejection ratio—A measure of the ability of a differential amplifier to reject interference from a common-mode signal, usually expressed in decibels (dB).
common-mode rejection	The ability of an electronic system to cancel any electronic noise pick-up that is common to both the positive and negative polarities of the input leads to the instrument front end. Common mode rejection is only a relevant specification for systems having a balanced or differential input.
common-mode signal	<ol style="list-style-type: none">1. Any voltage present at the instrumentation amplifier inputs with respect to amplifier ground.2. The signal, relative to the instrument chassis or computer's ground, of the signals from a differential input. This is often a noise signal, such as 50 or 60 Hz hum.
connector	<ol style="list-style-type: none">1. A device that provides electrical connection.2. A fixture (either male or female) attached to a cable or chassis for quickly making and breaking one or more circuits. A symbol that connects points on a flowchart.
convert rate	Reciprocal of the interchannel delay.
count	The number of events, such as zero crossings, pulses, or cycles.
counter	<ol style="list-style-type: none">1. Software. A memory location used to store a count of certain occurrences.2. Hardware. A circuit that counts events. When it refers to an instrument, it refers to a frequency counter.

counter/timer A circuit that counts external pulses or clock pulses (timing).

D

D GND Digital ground signal.

D-SUB connector A serial connector.

DAC Digital-to-Analog Converter—An electronic device, often an integrated circuit, that converts a digital number into a corresponding analog voltage or current.

In the instrumentation world, DACs can be used to generate arbitrary waveform shapes, defined by the software algorithm that computes the digital data pattern, which is fed to the DAC.

DAQ 1. Data acquisition—The process of collecting and measuring electrical signals from sensors, transducers, and test probes or fixtures and inputting them to a computer for processing.
 2. Data acquisition—The process of collecting and measuring the same kinds of electrical signals with A/D and/or DIO devices plugged into a computer, and possibly generating control signals with D/A and/or DIO devices in the same computer.

DAQ device A device that acquires or generates data and can contain multiple channels and conversion devices. DAQ devices include plug-in devices, PCMCIA cards, and DAQPad devices, which connect to a computer USB or 1394 (FireWire®) port. SCXI modules are considered DAQ devices.

DAQ-STC2 Data acquisition system timing controller chip.

data acquisition The general concept of acquiring data, as in *begin data acquisition* or *data acquisition and control*. See also DAQ.

data transfer	<p>A technique for moving digital data from one system to another.</p> <p>Options for data transfer are DMA, interrupt, and programmed I/O. For programmed I/O transfers, the CPU in the PC reads data from the DAQ device whenever the CPU receives a software signal to acquire a single data point. Interrupt-based data transfers occur when the DAQ device sends an interrupt to the CPU, telling the CPU to read the acquired data from the DAQ device. DMA transfers use a DMA controller, instead of the CPU, to move acquired data from the device into computer memory. Even though high-speed data transfers can occur with interrupt and programmed I/O transfers, they require the use of the CPU to transfer data. DMA transfers are able to acquire data at high speeds and keep the CPU free for performing other tasks at the same time.</p>
dB	<p>Decibel—The unit for expressing a logarithmic measure of the ratio of two signal levels: $\text{dB} = 20\log_{10} V_1/V_2$, for signals in volts.</p>
DC	<p>Direct current—although the term speaks of current, many different types of DC measurements are made, including DC Voltage, DC current, and DC power.</p>
device	<p>A plug-in data acquisition product, card, or pad that can contain multiple channels and conversion devices. Plug-in products, PCMCIA cards, and devices such as the DAQPad-1200, which connects to your computer parallel port, are all examples of DAQ devices. SCXI modules are distinct from devices, with the exception of the SCXI-1200, which is a hybrid.</p>
DIFF	<p>Differential mode—An analog input mode consisting of two terminals, both of which are isolated from computer ground, whose difference is measured.</p>
differential input	<p>An input circuit that actively responds to the difference between two terminals, rather than the difference between one terminal and ground. Often associated with balanced input circuitry, but also may be used with an unbalanced source.</p>
digital I/O	<p>The capability of an instrument to generate and acquire digital signals.</p> <p>Static digital I/O refers to signals where the values are set and held, or rarely change. Dynamic digital I/O refers to digital systems where the signals are continuously changing, often at multi-MHz clock rates.</p>
digital signal	<p>A representation of information by a set of discrete values according to a prescribed law. These values are represented by numbers.</p>

digital trigger	A TTL level signal having two discrete levels—A high and a low level.
DIO	Digital input/output.
DMA	Direct Memory Access—A method by which data can be transferred to/from computer memory from/to a device or memory on the bus while the processor does something else. DMA is the fastest method of transferring data to/from computer memory.
DMA controller chip	Performs the transfers between memory and I/O devices independently of the CPU.
driver	Software unique to the device or type of device, and includes the set of commands the device accepts.

E

E Series	A standard architecture for instrumentation-class, multichannel data acquisition devices.
edge detection	A technique that locates an edge of an analog signal, such as the edge of a square wave.
EEPROM	Electrically Erasable Programmable Read-Only Memory—ROM that can be erased with an electrical signal and reprogrammed. Some SCXI modules contain an EEPROM to store measurement-correction coefficients.
encoder	A device that converts linear or rotary displacement into digital or pulse signals. The most popular type of encoder is the optical encoder, which uses a rotating disk with alternating opaque areas, a light source, and a photodetector.
EXTCLK	External clock signal.
external trigger	A voltage pulse from an external source that causes a DAQ operation to begin.
EXTREF	External reference signal.

F

FIFO	<p>First-In-First-Out memory buffer—A data buffering technique that functions like a shift register where the oldest values (first in) come out first. Many DAQ products and instruments use FIFOs to buffer digital data from an A/D converter, or to buffer the data before or after bus transmission.</p> <p>The first data stored is the first data sent to the acceptor. FIFOs are often used on DAQ devices to temporarily store incoming or outgoing data until that data can be retrieved or output. For example, an analog input FIFO stores the results of A/D conversions until the data can be retrieved into system memory, a process that requires the servicing of interrupts and often the programming of the DMA controller. This process can take several milliseconds in some cases. During this time, data accumulates in the FIFO for future retrieval. With a larger FIFO, longer latencies can be tolerated. In the case of analog output, a FIFO permits faster update rates, because the waveform data can be stored on the FIFO ahead of time. This again reduces the effect of latencies associated with getting the data from system memory to the DAQ device.</p>
filter	<p>A physical device or digital algorithm that selectively removes noise from a signal, or emphasizes certain frequency ranges and de-emphasizes others. Electronic filters include lowpass, band-pass, and highpass types. Digital filters can operate on numeric data to perform equivalent operations on digitized analog data or to enhance video images.</p>
filtering	<p>A type of signal conditioning that allows you to filter unwanted frequency components from the signal you are trying to measure.</p>
floating	<p>The condition where a common mode voltage exists, or may exist, between earth ground and the instrument or circuit of interest. Neither the high, nor the low side of a circuit is at earth potential.</p>
floating signal sources	<p>Signal sources with voltage signals that are not connected to an absolute reference of system ground. Also called non-referenced signal sources. Some common examples of floating signal sources are batteries, transformers, and thermocouples.</p>
FREQ OUT	<p>Frequency Output signal.</p>
frequency	<p>The number of alternating signals that occur per unit time.</p>
ft	<p>Feet.</p>

- function
1. A built-in execution element, comparable to an operator, function, or statement in a conventional language.
 2. A set of software instructions executed by a single line of code that may have input and/or output parameters and returns a value when executed.

G

glitch An unwanted signal excursion of short duration that is usually unavoidable.

GND *See* ground.

- ground
1. A pin.
 2. An electrically neutral wire that has the same potential as the surrounding earth. Normally, a noncurrent-carrying circuit intended for safety.
 3. A common reference point for an electrical system.

H

hardware The physical components of a computer system, such as the circuit boards, plug-in devices, chassis, enclosures, peripherals, and cables.

hardware triggering A form of triggering where you set the start time of an acquisition and gather data at a known position in time relative to a trigger signal.

- Hz
1. Hertz—The SI unit for measurement of frequency. One hertz (Hz) equals one cycle per second.
 2. The number of scans read or updates written per second.

hysteresis Lag between making a change and the effect of the change.

I

I/O Input/Output—The transfer of data to/from a computer system involving communications channels, operator interface devices, and/or data acquisition and control interfaces.

impedance	<ol style="list-style-type: none"> 1. The electrical characteristic of a circuit expressed in ohms and/or capacitance/inductance. 2. Resistance.
in.	Inch or inches.
instrument driver	A set of high-level software functions that controls a specific GPIB, VXI, or RS232 programmable instrument or a specific plug-in DAQ device. Instrument drivers are available in several forms, ranging from a function callable language to a virtual instrument (VI) in LabVIEW.
instrumentation amplifier	A circuit whose output voltage with respect to ground is proportional to the difference between the voltages at its two inputs. An instrumentation amplifier normally has high-impedance differential inputs and high common-mode rejection.
interchannel delay	Amount of time that passes between sampling consecutive channels in an AI scan list. The interchannel delay must be short enough to allow sampling of all the channels in the channel list, within the sample interval. The greater the interchannel delay, the more time the PGIA is allowed to settle before the next channel is sampled. The interchannel delay is regulated by ai/ConvertClock.
interface	Connection between one or more of the following: hardware, software, and the user. For example, hardware interfaces connect two other pieces of hardware.
interrupt, interrupt request line	<ol style="list-style-type: none"> 1. A means for a device to notify another device that an event occurred. 2. A computer signal indicating that the CPU should suspend its current task to service a designated activity.
I_{OH}	Current, output high.
I_{OL}	Current, output low.
IRQ	<i>See</i> interrupt, interrupt request line.
K	
kHz	Kilohertz—A unit of frequency; $1 \text{ kHz} = 10^3 = 1,000 \text{ Hz}$.
kS	1,000 samples.

L

LabVIEW	A graphical programming language.
LED	Light-Emitting Diode—A semiconductor light source.
lowpass filter	A filter that passes signals below a cutoff frequency while blocking signals above that frequency.
LSB	Least Significant Bit.

M

m	Meter.
M Series	An architecture for instrumentation-class, multichannel data acquisition devices based on the earlier E Series architecture with added new features.
measurement	The quantitative determination of a physical characteristic. In practice, measurement is the conversion of a physical quantity or observation to a domain where a human being or computer can determine the value.
measurement device	DAQ devices, such as the M Series multifunction I/O (MIO) devices, SCXI signal conditioning modules, and switch modules.
MHz	Megahertz—A unit of frequency; $1 \text{ MHz} = 10^6 \text{ Hz} = 1,000,000 \text{ Hz}$.
micro (μ)	The numerical prefix designating 10^{-6} .
MIO	Multifunction I/O—DAQ module. Designates a family of data acquisition products that have multiple analog input channels, digital I/O channels, timing, and optionally, analog output channels. An MIO product can be considered a miniature mixed signal tester, due to its broad range of signal types and flexibility. Also known as multifunction DAQ.
MITE	MXI Interface To Everything—A custom ASIC designed by National Instruments that implements the PCI bus interface. The MITE supports bus mastering for high-speed data transfers over the PCI bus.
module	A board assembly and its associated mechanical parts, front panel, optional shields, and so on. A module contains everything required to occupy one or more slots in a mainframe. SCXI and PXI devices are modules.

monotonicity	A characteristic of a DAC in which the analog output always increases as the values of the digital code input to it increase.
multichannel	Pertaining to a radio-communication system that operates on more than one channel at the same time. The individual channels might contain identical information, or they might contain different signals.
multifunction DAQ	See MIO .
multiplex	To assign more than one signal to a channel. See also mux.
mux	<p>Multiplexer—A set of semiconductor or electromechanical switches arranged to select one of many inputs to a single output. The majority of DAQ cards have a multiplexer on the input, which permits the selection of one of many channels at a time.</p> <p>A switching device with multiple inputs that sequentially connects each of its inputs to its output, typically at high speeds, in order to measure several signals with a single analog input channel.</p>

N

NI	National Instruments.
NI-DAQ	The driver software needed to use National Instruments DAQ devices and SCXI components. Some devices use Traditional NI-DAQ (Legacy); others use NI-DAQmx.
NI-DAQmx	The latest NI-DAQ driver with new VIs, functions, and development tools for controlling measurement devices. The advantages of NI-DAQmx over earlier versions of NI-DAQ include the DAQ Assistant for configuring channels and measurement tasks for your device for use in LabVIEW, LabWindows/CVI, and Measurement Studio; increased performance such as faster single-point analog I/O; and a simpler API for creating DAQ applications using fewer functions and VIs than earlier versions of NI-DAQ.
NI-PGIA	See instrumentation amplifier .
non-referenced signal sources	Signal sources with voltage signals that are not connected to an absolute reference or system ground. Also called floating signal sources. Some common example of non-referenced signal sources are batteries, transformers, or thermocouples.

NRSE Non-Referenced Single-Ended mode—All measurements are made with respect to a common (NRSE) measurement system reference, but the voltage at this reference can vary with respect to the measurement system ground.

O

offset The unwanted DC voltage due to amplifier offset voltages added to a signal.

P

PCI Peripheral Component Interconnect—A high-performance expansion bus architecture originally developed by Intel to replace ISA and EISA. It offers a theoretical maximum transfer rate of 132 MB/s.

PCI Express A high-performance expansion bus architecture originally developed by Intel to replace PCI. PCI Express offers a theoretical maximum transfer rate that is dependent upon lane width. A $\times 1$ link theoretically provides 250 MB/s in each direction—to and from the device. Once overhead is accounted for, a $\times 1$ link can provide approximately 200 MB/s of input capability and 200 MB/s of output capability. Increasing the number of lanes in a link increases maximum throughput by approximately the same factor.

PCIe *See* PCI Express.

period The period of a signal, most often measured from one zero crossing to the next zero crossing of the same slope. The period of a signal is the reciprocal of its frequency (in Hz). Period is designated by the symbol T.

periods The number of periods of a signal.

PFI Programmable Function Interface.

PGIA Programmable Gain Instrumentation Amplifier.

physical channel *See* [channel](#).

Plug and Play devices	Devices that do not require DIP switches or jumpers to configure resources on the devices. Also called switchless devices port. <ol style="list-style-type: none">1. A communications connection on a computer or a remote controller;2. A digital port, consisting of four or eight lines of digital input and/or output.
posttriggering	The technique used on a DAQ device to acquire a programmed number of samples after trigger conditions are met.
power source	An instrument that provides one or more sources of AC or DC power. Also known as power supply.
ppm	Parts per million.
pretriggering	The technique used on a DAQ device to keep a continuous buffer filled with data, so that when the trigger conditions are met, the sample includes the data leading up to the trigger condition.
pulse	A signal whose amplitude deviates from zero for a short period of time.
pulse width	The time from the rising to the falling slope of a pulse (at 50% amplitude).
PXI	A rugged, open system for modular instrumentation based on CompactPCI, with special mechanical, electrical, and software features. The PXIbus standard was originally developed by National Instruments in 1997, and is now managed by the PXIbus Systems Alliance.
PXI Express	PCI Express eXtensions for Instrumentation—The PXI implementation of PCI Express, a scalable full-simplex serial bus standard that operates at 2.5 Gbps and offers both asynchronous and isochronous data transfers.
PXI_STAR	A special set of trigger lines in the PXI backplane for high-accuracy device synchronization with minimal latencies on each PXI slot. Only devices in the PXI Star controller Slot 2 can set signal on this line. For additional information concerning PXI star signal specifications and capabilities, read the PXI Specification located at www.pxisa.org/specs .

Q

quadrature encoder An encoding technique for a rotating device where two tracks of information are placed on the device, with the signals on the tracks offset by 90° from each other. This makes it possible to detect the direction of the motion.

R

range The maximum and minimum parameters between which a sensor, instrument, or device operates with a specified set of characteristics. This may be a voltage range or a frequency range.

real time

1. Displays as it comes in; no delays.
2. A property of an event or system in which data is processed and acted upon as it is acquired instead of being accumulated and processed at a later time.
3. Pertaining to the performance of a computation during the actual time that the related physical process transpires so results of the computation can be used in guiding the physical process.

RSE Referenced Single-Ended configuration—All measurements are made with respect to a common reference measurement system or a ground. Also called a grounded measurement system.

RTSI Real-Time System Integration.

RTSI bus Real-Time System Integration bus—The National Instruments timing bus that connects DAQ devices directly, by means of connectors on top of the devices, for precise synchronization of functions.

S

s Seconds.

S Samples.

sample counter The clock that counts the output of the channel clock, in other words, the number of samples taken. On devices with simultaneous sampling, this counter counts the output of the scan clock and hence the number of scans.

scan	One or more analog or digital input samples. Typically, the number of input samples in a scan is equal to the number of channels in the input group. For example, one pulse from the scan clock produces one scan which acquires one new sample from every analog input channel in the group.
scan interval	Controls how often a scan is initialized; is regulated by the AI Sample Clock signal.
scan rate	Reciprocal of the scan interval.
SCC	Signal Conditioning Carriers—A compact, modular form factor for signal conditioning modules.
SCXI	Signal Conditioning eXtensions for Instrumentation—The National Instruments product line for conditioning low-level signals within an external chassis near sensors so that only high-level signals are sent to DAQ devices in the noisy PC environment.
sensor	A device that responds to a physical stimulus (heat, light, sound, pressure, motion, flow, and so on), and produces a corresponding electrical signal. Primary characteristics of sensors are sensitivity, frequency range, and linearity.
signal conditioning	<ol style="list-style-type: none">1. Electronic equipment that makes transducer or other signals suitable in level and range to be transmitted over a distance, or to interface with voltage input instruments.2. The manipulation of signals to prepare them for digitizing.
signal source	A generic term for any instrument in the family of signal generators.
signals	Signals are waveforms containing information. Although physical signals can be in the form of mechanical, electromagnetic, or other forms, they are most often converted to electronic form for measurement.
single trigger mode	When the arbitrary waveform generator goes through the staging list only once.
single-buffered	Describes a device that acquires a specified number of samples from one or more channels and returns the data when the acquisition is complete.
single-ended input	A circuit that responds to the voltage on one input terminal and ground. <i>See also</i> differential input .

single-ended output	A circuit whose output signal is present between one output terminal and ground.
software applications	The programs that run on your computer and perform a specific user-oriented function, such as accounting, program development, measurement, or data acquisition. In contrast, operating system functions basically perform the generic "housekeeping" of the machine, which is independent of any specific application. Operating system functions include the saving of data (file system), handling of multiple programs at the same time (multi-tasking), network interconnection, printing, and keyboard/user interface interaction.
software triggering	A method of triggering in which you simulate an analog trigger using software. Also called <i>conditional retrieval</i> .
source impedance	A parameter of signal sources that reflects current-driving ability of voltage sources (lower is better) and the voltage-driving ability of current sources (higher is better).
synchronous	<ol style="list-style-type: none"> 1. Hardware—A property of an event that is synchronized to a reference clock. 2. Software—A property of a function that begins an operation and returns only when the operation is complete. A synchronous process is, therefore, <i>locked</i> and no other processes can run during this time.

T

task	In NI-DAQmx, a collection of one or more channels, timing, and triggering and other properties that apply to the task itself. Conceptually, a task represents a measurement or generation you want to perform.
TC	<i>See</i> terminal count.
terminal	An object or region on a node through which data passes.
terminal count	The highest value of a counter.
t_{gh}	Gate hold time.
t_{gsu}	Gate setup time.
t_{gw}	Gate pulse width.

Timebase	The reference signals for controlling the basic accuracy of time or frequency-based measurements. For instruments, timebase refers to the accuracy of the internal clock.
t_{out}	Output delay time.
Traditional NI-DAQ (Legacy)	An upgrade to the earlier version of NI-DAQ. Traditional NI-DAQ (Legacy) has the same VIs and functions and works the same way as NI-DAQ 6.9.x. You can use both Traditional NI-DAQ (Legacy) and NI-DAQmx on the same computer, which is not possible with NI-DAQ 6.9.x.
transducer	A device that responds to a physical stimulus (heat, light, sound, pressure, motion, flow, and so on), and produces a corresponding electrical signal. <i>See also</i> sensor .
trigger	<ol style="list-style-type: none">1. Any event that causes or starts some form of data capture.2. An external stimulus that initiates one or more instrument functions. Trigger stimuli include a front panel button, an external input voltage pulse, or a bus trigger command. The trigger may also be derived from attributes of the actual signal to be acquired, such as the level and slope of the signal.
t_{sc}	Source clock period.
t_{sp}	Source pulse width.
TTL	Transistor-Transistor Logic—A digital circuit composed of bipolar transistors wired in a certain manner. A typical medium-speed digital technology. Nominal TTL logic levels are 0 and 5 V.

U

USB	Universal Serial Bus—A 480 Mbit/s serial bus with up to 12-Mbps bandwidth for connecting computers to keyboards, printers, and other peripheral devices. USB 2.0 retains compatibility with the original USB specification.
-----	---

V

V	Volts.
V_{cm}	Common-mode voltage.

V_g	Ground loop voltage.
V_{IH}	Volts, input high.
V_{IL}	Volts, input low.
V_{in}	Volts in.
V_m	Measured voltage.
V_{OH}	Volts, output high.
V_{OL}	Volts, output low.
V_{out}	Volts out.
V_s	Signal source voltage.
virtual channel	See channel .

W

waveform	<ol style="list-style-type: none">1. The plot of the instantaneous amplitude of a signal as a function of time.2. Multiple voltage readings taken at a specific sampling rate.
----------	---

Index

Symbols

+5 V power input, 3-3
+5 V power output, 3-2
+5 V power source, 3-2
.NET languages documentation, *xvi*

Numerics

100 kHz Timebase, 12-2
20 MHz Timebase, 12-1
80 MHz Timebase, 12-1

A

A/D converter, 4-2
AC return path, creating, 11-3
accessories
 choosing for your device, 1-3
acquisition
 circular-buffered, 4-10
 double-buffered, 4-10
acquisitions
 hardware-timed, 4-9
 on-demand, 4-9
 software-timed, 4-9
AI channels, sampling with AI Sample Clock
 and AI Convert Clock, B-2
AI Convert Clock signal, 4-16
AI Convert Clock Timebase signal, 4-20
AI data acquisition methods, 4-9
AI FIFO, 4-2
AI Hold Complete Event signal, 4-21
AI Pause Trigger signal, 4-23
AI Reference Trigger signal, 4-22
AI Sample Clock signal, 4-14
AI Sample Clock Timebase signal, 4-16
AI Start Trigger signal, 4-21

AI timing signals, 4-11
ai/ConvertClock, 4-16
ai/ConvertClockTimebase, 4-20
ai/HoldCompleteEvent, 4-21
ai/PauseTrigger, 4-23
ai/ReferenceTrigger, 4-22
ai/SampleClock, 4-14
ai/SampleClockTimebase, 4-16
ai/StartTrigger, 4-21
analog input, 4-1
 charge injection, B-1
 circuitry, 4-1
 connecting signals, 5-1, 6-1
 connecting through I/O connector, 4-1
 crosstalk when sampling multiple
 channels, B-1
 data acquisition methods, 4-9
 differential, troubleshooting, B-1
 getting started with applications in
 software, 4-24
 ghost voltages when sampling multiple
 channels, B-1
 ground-reference settings, 4-2
MUX, 4-1
 sampling channels with AI Sample Clock
 and AI Convert Clock, B-2
 timing signals, 4-11
 triggering, 4-10
 troubleshooting, B-1
analog input data acquisitions, 4-9
analog input signals, 4-11
 AI Convert Clock, 4-16
 AI Convert Clock Timebase, 4-20
 AI Hold Complete Event, 4-21
 AI Pause Trigger, 4-23
 AI Reference Trigger, 4-22
 AI Sample Clock, 4-14

- AI Sample Clock Timebase, 4-16
- AI Start Trigger, 4-21
- analog output, 7-1
 - circuitry, 7-1
 - connecting signals, 7-4
 - data generation methods, 7-2
 - fundamentals, 7-1
 - getting started with applications in software, 7-9
 - glitches on the output signal, 7-2
 - timing signals, 7-5
 - triggering, 7-4
 - troubleshooting, B-3
- analog output data generation, 7-2
- analog output signals, 7-5
 - AO Pause Trigger, 7-6
 - AO Sample Clock, 7-7
 - AO Sample Clock Timebase, 7-8
 - AO Start Trigger, 7-5
- analog output trigger signals, 7-4
- analog to digital converter, 4-2
- ANSI C documentation, xv
- AO FIFO, 7-1
- AO Pause Trigger signal, 7-6
- AO range, 7-2
- AO Sample Clock, 7-2
 - Timebase signal, 7-8
- AO sample clock
 - signal, 7-7
- AO Sample Clock signal, 7-7
- AO Sample Clock Timebase signal, 7-8
- AO Start Trigger signal, 7-5
- ao/PauseTrigger, 7-6
- ao/SampleClock, 7-7
- ao/StartTrigger, 7-5
- applications
 - counter input, 9-2
 - counter output, 9-20
 - edge counting, 9-2
- arm start trigger, 9-31
- avoiding scanning faster than necessary, 4-8

B

- buffered edge counting, 9-3
 - non-cumulative, 9-4
- buffered hardware-timed acquisitions, 4-10
- buffered hardware-timed generations, 7-3
- buffered period measurement, 9-7
- buffered pulse-width measurement, 9-5
- buffered semi-period measurement, 9-9
- buffered two-signal edge-separation measurement, 9-19
- bus
 - interface, 13-1

C

- calibration, 2-2
- calibration certificate (NI resources), C-2
- calibration circuitry, 2-2
- cascading counters, 9-33
- changing data transfer methods
 - between USB signal stream and programmed I/O, 13-2
- channel scanning order, 4-7
- channel Z behavior, 9-17
- channels
 - sampling with AI Sample Clock and AI Convert Clock, B-2
- charge injection, B-1
- choosing frequency measurement, 9-13
- circular-buffered acquisition, 4-10
- clock
 - generation, 12-1
 - sample, 9-32
- common-mode noise, 11-2
- configuring AI ground-reference settings in software, 4-5
- connecting
 - analog input signals, 5-1, 6-1
 - analog output signals, 7-4
 - digital I/O signals, 8-3
 - floating signal sources, 5-3

- ground-referenced signal sources, 5-9
- PFI input signals, 10-3
- connections
 - for floating signal sources, 5-9
 - single-ended for floating signal sources, 5-9
 - single-ended, RSE configuration, 5-9
- connector
 - information, 3-1
 - USB-6210 pinout, A-1
 - USB-6211 pinout, A-4
 - USB-6215 pinout, A-4
 - USB-6218 pinout, A-7
- considerations
 - for field wiring, 4-11
 - for multichannel scanning, 4-6
- continuous pulse train generation, 9-22
- controlling counting direction, 9-2
- conventions used in the manual, *xiii*
- counter input and output, 9-29
- Counter *n* A signal, 9-28
- Counter *n* Aux signal, 9-27
- Counter *n* B signal, 9-28
- Counter *n* Gate signal, 9-27
- Counter *n* HW Arm signal, 9-28
- Counter *n* Internal Output signal, 9-29
- Counter *n* Source signal, 9-26
- Counter *n* TC signal, 9-29
- Counter *n* Up_Down signal, 9-28
- Counter *n* Z signal, 9-28
- counter output applications, 9-20
- counter signals
 - Counter *n* A, 9-28
 - Counter *n* Aux, 9-27
 - Counter *n* B, 9-28
 - Counter *n* Gate, 9-27
 - Counter *n* HW Arm, 9-28
 - Counter *n* Internal Output, 9-29
 - Counter *n* Source, 9-26
 - Counter *n* TC, 9-29
 - Counter *n* Up_Down, 9-28

- FREQ OUT, 9-29
- Frequency Output, 9-29
- counter terminals, default, 9-29
- counters, 9-1
 - cascading, 9-33
 - connecting terminals, 9-29
 - duplicate count prevention, 9-35
 - edge counting, 9-2
 - filters, 9-33
 - generation, 9-20
 - input applications, 9-2
 - other features, 9-32
 - output applications, 9-20
 - prescaling, 9-34
 - pulse train generation, 9-22
 - retriggerable single pulse generation, 9-21
 - simple pulse generation, 9-20
 - single pulse generation, 9-20
 - single pulse generation with start trigger, 9-20
 - timing signals, 9-25
 - triggering, 9-31
- counting edges, 9-2
- creating an AC return path, 11-3
- crosstalk when sampling multiple channels, B-1

D

- DACs, 7-1
- DAQ hardware, 2-1
- DAQ system, 2-1
- DAQ-STC2, 2-2
- data
 - acquisition methods, 4-9
 - generation methods, 7-2
 - transfer methods, 13-1
 - changing, 13-2
 - programmed I/O, 13-2
 - USB signal stream, 13-1

- Declaration of Conformity (NI resources), C-1
 - default
 - counter terminals, 9-29
 - NI-DAQmx counter/timer pins, 9-29
 - pins, 9-29
 - device
 - information, A-1
 - pinouts, 1-3
 - specifications, 1-3, A-1
 - USB-6210, A-1
 - USB-6211, A-4
 - USB-6215, A-4
 - USB-6218, A-7
 - diagnostic tools (NI resources), C-1
 - DIFF connections
 - using with floating signal sources, 5-5
 - using with ground-referenced signal sources, 5-12
 - when to use with floating signal sources, 5-3
 - when to use with ground-referenced signal sources, 5-10
 - differential analog input, troubleshooting, B-1
 - differential connections
 - using with floating signal sources, 5-5
 - using with ground-referenced signal sources, 5-12
 - when to use with floating signal sources, 5-3
 - when to use with ground-referenced signal sources, 5-10
 - digital
 - isolation, 11-2
 - isolators, 11-1
 - digital I/O, 8-1
 - block diagram, 8-1
 - circuitry, 8-1
 - connecting signals, 8-3
 - getting started with applications in software, 8-4
 - I/O protection, 8-2
 - static DIO, 8-2
 - triggering, 14-1
 - digital routing, 12-1
 - digital signals
 - connecting, 8-3
 - digital source, triggering, 14-1
 - documentation
 - conventions used in manual, *xiii*
 - NI resources, C-1
 - related documentation, *xiv*
 - double-buffered acquisition, 4-10
 - drivers (NI resources), C-1
 - duplicate count prevention, 9-35
 - enabling in NI-DAQmx, 9-38
 - example, 9-36
 - prevention example, 9-37
- ## E
- edge counting, 9-2
 - buffered, 9-3
 - non-cumulative buffered, 9-4
 - on-demand, 9-2
 - sample clock, 9-3
 - single point, 9-2
 - edge-separation measurement
 - buffered two-signal, 9-19
 - single two-signal, 9-18
 - enabling duplicate count prevention in NI-DAQmx, 9-38
 - encoders, quadrature, 9-15
 - encoding
 - X1, 9-15
 - X2, 9-16
 - X4, 9-16
 - equivalent time sampling, 9-24
 - examples (NI resources), C-1
 - exporting timing output signals using PFI terminals, 10-3

F

- features, counter, 9-32
- field wiring considerations, 4-11
- filters
 - counter, 9-33
 - PFI, 10-4
- floating signal sources
 - connecting, 5-3
 - description, 5-3
 - using in differential mode, 5-5
 - using in NRSE mode, 5-8
 - using in RSE mode, 5-9
 - when to use in differential mode, 5-3
 - when to use in NRSE mode, 5-4
 - when to use in RSE mode, 5-3
- FREQ OUT signal, 9-29
- frequency
 - division, 9-24
 - generation, 9-23
 - generator, 9-23
- frequency measurement, 9-10
- Frequency Output signal, 9-29

G

- generations
 - analog output data, 7-2
 - buffered hardware-timed, 7-3
 - clock, 12-1
 - continuous pulse train, 9-22
 - frequency, 9-23
 - hardware-timed, 7-2
 - pulse for ETS, 9-24
 - pulse train, 9-22
 - retriggerable single pulse, 9-21
 - simple pulse, 9-20
 - single pulse, 9-20
 - single pulse with start trigger, 9-20
 - software-timed, 7-2
- getting started, 1-2

- AI applications in software, 4-24
- AO applications in software, 7-9
- DIO applications in software, 8-4
- ghost voltages when sampling multiple channels, B-1
- ground-reference connections, checking, B-1
- ground-reference settings, 4-2, 4-3
 - analog input, 4-3
- ground-referenced signal sources
 - connecting, 5-9
 - description, 5-9
 - using in differential mode, 5-12
 - using in NRSE mode, 5-13
 - when to use in differential mode, 5-10
 - when to use in NRSE mode, 5-10
 - when to use in RSE mode, 5-11

H

- hardware, 1-3, 2-1
- hardware-timed acquisitions, 4-9
- hardware-timed generations, 7-2
- help, technical support, C-1

I

- I/O connector, 3-1
 - USB-6210 pinout, A-1
 - USB-6211 pinout, A-4
 - USB-6215 pinout, A-4
 - USB-6218 pinout, A-7
- I/O protection, 8-2, 10-6
- input signals
 - using PFI terminals as, 10-2
- insertion of grounded channels between signal channels, 4-7
- installation
 - hardware, 1-3
 - NI-DAQ, 1-2
 - other software, 1-2
- instrument drivers (NI resources), C-1

instrumentation amplifier, 4-2
interface, bus, 13-1
isolated DAQ devices, 11-1
 benefits, 11-2
 common-mode noise, 11-2
isolators, 11-1

K

KnowledgeBase, C-1

L

LabVIEW documentation, *xiv*
LabWindows/CVI documentation, *xv*
LED
 USB-6210, A-3
 USB-6211, A-6
 USB-6215, A-6
 USB-6218, A-9
low impedance sources, 4-6

M

M Series
 information, A-1
 specifications, *xvi*, A-1
Measurement Studio documentation, *xv*
measurements
 buffered period, 9-7
 buffered pulse-width, 9-5
 buffered semi-period, 9-9
 buffered two-signal edge-separation, 9-19
 choosing frequency, 9-13
 frequency, 9-10
 period, 9-6
 position, 9-15
 pulse-width, 9-5
 semi-period, 9-9
 single period, 9-7
 single pulse-width, 9-5

single semi-period, 9-9
single two-signal edge-separation, 9-18
two-signal edge-separation, 9-18
using quadrature encoders, 9-15
using two pulse encoders, 9-17

measuring
 high frequency with two counters, 9-11
 large range of frequencies using two
 counters, 9-12
 low frequency with one counter, 9-10
 averaged, 9-11
methods, data transfer, 13-1
minimizing
 glitches on the output signal, 7-2
 output signal glitches, B-3
 voltage step between adjacent
 channels, 4-8
multichannel scanning considerations, 4-6
MUX, 4-1

N

National Instruments support and
 services, C-1
NI support and services, C-1
NI-DAQ documentation, *xiv*
 device documentation browser, *xvi*
NI-DAQmx
 default counter terminals, 9-29
 enabling duplicate count prevention, 9-38
NI-PGIA, 4-2
non-buffered
 hardware-timed acquisitions, 4-10
non-cumulative buffered edge counting, 9-4
non-referenced single-ended connections
 using with floating signal sources, 5-8
 using with ground-referenced signal
 sources, 5-13
when to use with floating signal
 sources, 5-4

- when to use with ground-referenced signal sources, 5-10
- NRSE connections
 - using with floating signal sources, 5-8
 - using with ground-referenced signal sources, 5-13
 - when to use with floating signal sources, 5-4
 - when to use with ground-referenced signal sources, 5-10

O

- on-demand
 - acquisitions, 4-9
 - edge counting, 9-2
 - timing, 4-9
- order of channels for scanning, 4-7
- other software, 1-2
- output signal glitches, B-3
- output signals, minimizing glitches, 7-2
- overview, 2-1

P

- pause trigger, 9-31
- period measurement, 9-6
 - buffered, 9-7
 - single, 9-7
- PFI, 10-1
 - connecting input signals, 10-3
 - exporting timing output signals using PFI terminals, 10-3
 - filters, 10-4
 - I/O protection, 10-6
 - programmable power-up states, 10-6
 - using terminals as static digital I/Os, 10-3
 - using terminals as timing input signals, 10-2
- PFI terminals as static digital I/Os, 10-3
- pin assignments. *See* pinouts

- pinouts
 - counter default, 9-29
 - device, 1-3
 - USB-6210, A-1
 - USB-6211, A-4
 - USB-6215, A-4
 - USB-6218, A-7
- pins, default, 9-29
- position measurement, 9-15
- power, +5 V, 3-2
- power, +5 V input, 3-3
- power, +5 V output, 3-2
- power-up states, 10-6
- prescaling, 9-34
- programmable function interface, 10-1
- programmable power-up states, 10-6
- programmed I/O, 13-2
 - changing data transfer methods, 13-2
- programming
 - devices in software, 2-4
- programming examples (NI resources), C-1
- pulse encoders, 9-17
- pulse generation for ETS, 9-24
- pulse train generation, 9-22
 - continuous, 9-22
- pulse-width measurement, 9-5
 - buffered, 9-5
 - single, 9-5

Q

- quadrature encoders, 9-15

R

- reciprocal frequency measurement, 9-12
- referenced single-ended connections
 - using with floating signal sources, 5-9
 - when to use with floating signal sources, 5-3

- when to use with ground-referenced signal sources, 5-11
- related documentation, *xiv*
- retriggerable single pulse generation, 9-21
- routing
 - digital, 12-1
- RSE configuration, 5-9
- RSE connections
 - using with floating signal sources, 5-9
 - when to use with floating signal sources, 5-3
 - when to use with ground-referenced signal sources, 5-11

S

- sample clock, 9-32
 - edge counting, 9-3
- scanning speed, 4-8
- semi-period measurement, 9-9
 - buffered, 9-9
 - single, 9-9
- sensors, 2-3
- settings
 - analog input ground-reference, 4-3
- signal conditioning, 2-3
- signal descriptions, 3-1
- signal sources
 - floating, 5-3
 - ground-referenced, 5-9
- Signal Stream, USB, 13-1
- signals
 - AI Convert Clock, 4-16
 - AI Convert Clock Timebase, 4-20
 - AI Hold Complete Event, 4-21
 - AI Pause Trigger, 4-23
 - AI Reference Trigger, 4-22
 - AI Sample Clock, 4-14
 - AI Sample Clock Timebase, 4-16
 - AI Start Trigger, 4-21
 - analog input, 4-11
 - analog output, 7-5
 - AO Pause Trigger, 7-6
 - AO Sample Clock, 7-7
 - AO Sample Clock Timebase, 7-8
 - AO Start Trigger, 7-5
 - connecting analog input, 5-1, 6-1
 - connecting analog output, 7-4
 - connecting digital I/O, 8-3
 - connecting PFI input, 10-3
 - Counter *n* A, 9-28
 - Counter *n* Aux, 9-27
 - Counter *n* B, 9-28
 - Counter *n* Gate, 9-27
 - Counter *n* HW Arm, 9-28
 - Counter *n* Internal Output, 9-29
 - Counter *n* Source, 9-26
 - Counter *n* TC, 9-29
 - Counter *n* Up_Down, 9-28
 - Counter *n* Z, 9-28
 - counters, 9-25
 - exporting timing output using PFI terminals, 10-3
 - FREQ OUT, 9-29
 - Frequency Output, 9-29
 - minimizing output glitches, B-3
 - output, minimizing glitches on, 7-2
- simple pulse generation, 9-20
- single
 - period measurement, 9-7
 - point edge counting, 9-2
 - pulse generation, 9-20
 - retriggerable, 9-21
 - with start trigger, 9-20
 - pulse-width measurement, 9-5
 - semi-period measurement, 9-9
 - two-signal edge-separation measurement, 9-18
- single-ended connections
 - RSE configuration, 5-9
- single-ended connections for floating signal sources, 5-9

- software
 - configuring AI ground-reference settings, 4-5
 - programming devices, 2-4
- software (NI resources), C-1
- software-timed
 - acquisitions, 4-9
 - generations, 7-2
- specifications, A-1
 - device, 1-3
 - USB-6210, A-3
 - USB-6211, A-6
 - USB-6215, A-6
 - USB-6218, A-9
- start
 - trigger, 9-31
- static DIO, 8-2
 - using PFI terminals as, 10-3
- support
 - technical, C-1
- switching from a large to a small input range, 4-7
- synchronous counting mode, 9-35

T

- technical support, *xvi*, C-1
- terminal configuration, 4-3
 - analog input, 4-1
- terminals
 - connecting counter, 9-29
 - NI-DAQmx default counter, 9-29
- Timebase
 - 100 kHz, 12-2
 - 20 MHz, 12-1
 - 80 MHz, 12-1
- timed acquisitions, 4-9
- timing output signals, exporting using PFI terminals, 10-3
- training, *xvi*
- training and certification (NI resources), C-1

- transducers, 2-3
- trigger, 14-1
 - arm start, 9-31
 - pause, 9-31
 - start, 9-31
- triggering, 14-1
 - analog input, 4-10
 - counter, 9-31
 - with a digital source, 14-1
- troubleshooting
 - analog input, B-1
 - analog output, B-3
- troubleshooting (NI resources), C-1
- two-signal edge-separation measurement, 9-18
 - buffered, 9-19
 - single, 9-18

U

- USB
 - Signal Streams, 13-1
- USB bulk transfers, 13-1
- USB signal stream
 - as a transfer method, 13-1
 - changing data transfer methods, 13-2
- USB-6210, A-1
 - analog input signals, 5-1
 - LED, A-3
 - pinout, A-1
 - specifications, A-3
- USB-6211, A-4
 - analog input signals, 5-1
 - LED, A-6
 - pinout, A-4
 - specifications, A-6
- USB-6215, A-4
 - analog input signals, 6-1
 - LED, A-6
 - pinout, A-4
 - specifications, A-6

USB-6218, A-7

analog input signals, 6-1

LED, A-9

pinout, A-7

specifications, A-9

using

low impedance sources, 4-6

using PFI terminals

as static digital I/Os, 10-3

as timing input signals, 10-2

to export timing output signals, 10-3

W

waveform generation

signals, 7-5

Web resources, C-1

X

X1 encoding, 9-15

X2 encoding, 9-16

X4 encoding, 9-16