

LOWRANCE

SIMRAD

B&G

Broadband 3G™ Radar Installation Guide

ENGLISH



www.bandg.com
www.simrad-yachting.com
www.lowrance.com

BLANK PAGE

Contents

6 Welcome

- 6 What is Broadband radar?
- 6 FMCW radar is different:
- 6 How does FMCW radar work?
- 7 Additional benefits of FMCW radar are:

8 Radar system overview

10 Installation

- 10 Tools Required
- 10 Choose the scanner location
- 11 Considerations for direct roof mounting
- 14 Connect interconnection cable to the scanner
- 15 Connect the interconnection cable to radar interface box

17 Connect the Broadband radar to your display

- 17 Lowrance HDS USA
- 18 Lowrance HDS Outside USA or with MARPA / Chart overlay
- 18 Simrad NSS (NMEA2000 network)
- 19 B&G Zeus
- 19 Simrad NSO, NSE and NSS, (SimNet network)

20 RI10 Connections

21 Connect power

22 Setup and Configuration

- 22 Entering radar setup on your display
- 22 Radar Status
- 23 Adjust bearing alignment...
- 23 Adjust local interference reject
- 23 Adjust antenna height
- 23 Sidelobe suppression
- 24 To start the radar
- 24 RI10 heading source selection
- 24 Dual radar setup:

26 Dimension Drawings

- 26 Scanner
- 27 Radar interface box

27 Maintenance

28 Specifications

- 29 Navico Broadband radar part numbers

30 RF exposure compliance certificate

Industry Canada

Operation is subject to the following two conditions:

- (1) this device may not cause interference, and
- (2) this device must accept any interference, including interference that may cause undesired operation of the device.

FCC Statement

- **Note:** This equipment has been tested and complies with the limits for a Class B digital device, pursuant to Part 15 of the FCC Rules. These limits are designed to provide reasonable protection against harmful interference in a normal installation. This equipment generates, uses and can radiate radio frequency energy and, if not installed and used in accordance with the instructions, may cause harmful interference to radio communications. However, there is no guarantee that interference will not occur in a particular installation. This device must accept any interference received, including interference that may cause undesired operation. If this equipment does cause harmful interference to radio or television reception, which can be determined by turning the equipment off and on, the user is encouraged to try to correct the interference by one or more of the following measures:
- Reorient or relocate the receiving antenna.
 - Increase the separation between the equipment and receiver.
 - Connect the equipment into an output on a circuit different from that to which the receiver is connected.
 - Consult the dealer or an experienced technician for help.
- **Note:** A shielded cable must be used when connecting a peripheral to the serial ports. Changes or modifications not expressly approved by the manufacturer could void the user's authority to operate the equipment.

CE Compliance

The equipment named in this declaration, is intended for use in international waters as well as coastal sea areas administered by countries of the E.U. and E.E.A.

Radar Transmit Emissions

- **Note:** Broadband 3G™ Radar is the second generation marine recreational radar from Navico that has Human Exposure Level RF Radiation of the Radar Transmitter outside the Radome well below the general public safety emission level of 1 mW/cm². This means the radar can be mounted safely in locations impossible with other pulse radars.
- **Note:** If a pulse radar and Broadband radar are mounted on the same vessel, do not transmit simultaneously as excessive interference is possible.



The broadband radar will not trigger X Band radar transponders, beacons, and SARTs due to the low output power and signal properties.

Disclaimer

As Navico is continuously improving this product, we retain the right to make changes to the product at any time which may not be reflected in this version of the manual. Please contact your nearest distributor if you require any further assistance.

It is the owner's sole responsibility to install and use the instrument and transducers in a manner that will not cause accidents, personal injury or property damage. The user of this product is solely responsible for observing safe boating practices.

NAVICO HOLDING AS. AND ITS SUBSIDIARIES, BRANCHES AND AFFILIATES DISCLAIM ALL LIABILITY FOR ANY USE OF THIS PRODUCT IN A WAY THAT MAY CAUSE ACCIDENTS, DAMAGE OR THAT MAY VIOLATE THE LAW.

Governing Language: This statement, any instruction manuals, user guides and other information relating to the product (Documentation) may be translated to, or has been translated from, another language (Translation). In the event of any conflict between any Translation of the Documentation, the English language version of the Documentation will be the official version of the Documentation.

This manual represents the product as at the time of printing. Navico Holding AS. and its subsidiaries, branches and affiliates reserve the right to make changes to specifications without notice.

Copyright © 2011 Navico Holding AS.

Warranty

The warranty card is supplied as a separate document.

In case of any queries, refer to the brand web site of your display or system.

www.lowrance.com

www.simrad-yachting.com

www.BandG.com

1

Welcome

Congratulations of your purchase of the latest technology available in recreational marine radar. The special features designed into this radar are:

“Revolutionary improvement in situational awareness” Provides unprecedented ability to distinguish hazards and other objects

Radar is finally easy enough for casual users – identifies targets clearly with out complicated tuning adjustments.

Navigation with unparalleled resolution and clarity at close ranges, where traditional radar completely obscures targets.

“Start faster, go longer” - 100% solid state design – no powerful microwave transmitter required! – provides InstantOn™ power up capability and low power consumption

Eliminate the 2-3 minute warm-up time typical of traditional radars

Conserve power with a standby drain less than one tenth of the best existing radars – especially great for sailboats and smaller power boats

No expensive magnetron replacement is ever required

“Incredibly approachable” - practically imperceptible transmit emissions are extremely safe, allowing you to mount it anywhere

Less than 1/10th the transmitted emissions of a mobile phone, can be safely mounted in proximity to passengers

Compatible with a wide range of Navico multi-function displays and heading sensors

What is Broadband radar?

The Navico Broadband radar uses FMCW (Frequency Modulated Continuous Wave) radar technology.

FMCW radar is different:

Firstly it is solid state – i.e. the transmitter is a semiconductor device, not based on magnetron technology. Secondly, it transmits a 1ms long signal of increasing frequency, rather than a short duration pulse. Thirdly, it measures the distance to a target not by timing the returned echoes, but by measuring the difference between the current transmitted frequency and echoed frequency. Hence FMCW – Frequency Modulated Continuous Wave.

The building up of the image over 360 degrees and the processing of the radar data is the same as for a magnetron radar.

How does FMCW radar work?

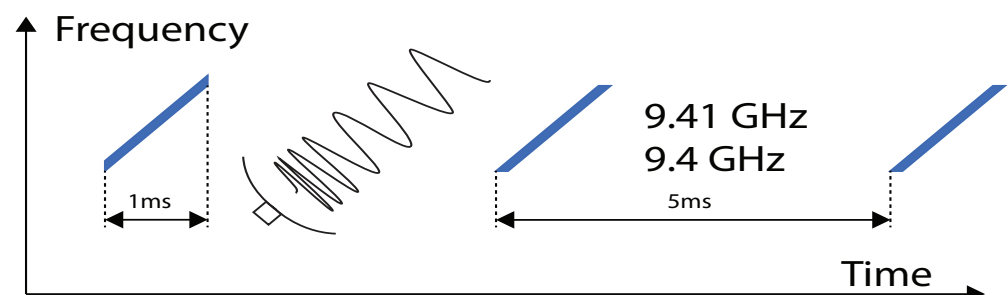

FMCW = Frequency Modulated Continuous Wave

The scanner transmits a 'rising tone' (Tx wave) with linearly increasing frequency. The wave propagates out from the transmitter retaining the frequency it had when it was transmitted. If it reflects off an object, it will return to the receiver, still at the frequency it had when originally transmitted.

Meanwhile, the transmitter continues to output an increasing frequency.

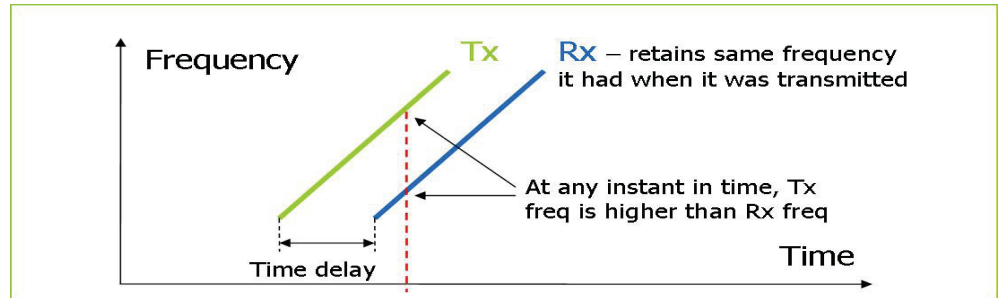

The difference between both the currently transmitted and received frequencies, coupled with the known rate of frequency increase, allows a time of flight to be calculated, from which distance is calculated.

Additional benefits of FMCW radar are:

Safety-

- low energy emissions. 1/10th of a mobile phone
- safe operation in anchorages and marinas
- instant power up. No warm up required

Short range performance -

- broadband radar can see within a few meters of the boat, compared to pulse radars, which can not see closer than 30 meters
- higher resolution clearly separates individual vessels and objects
- Up to five times better sea and rain clutter performance

Low power -

- suitable for small boats and yachts
- easier installation with lighter cabling and smaller connectors
- great for yachts on ocean passage

Instant power-up -

- conventional radars take 2-3 minutes to warm up the magnetron: Safety – 2 minutes is a long time if you are concerned about collision.
- convenience – switch it on and use it.

Easy to use -

- no constant adjusting required to obtain optimum performance
- no re-tuning between ranges. Means fast range change at all ranges.

2

Radar system overview

The Broadband radar is a state of the art navigation aid. It provides outstanding radar performance without the limitations of conventional pulse radars such as: dangerous high power microwaves, standby warm up time, 30 m blind spot (mainbang), high power consumption and large open arrays - which is what would be required to obtain the same image quality at shorter ranges.

The Broadband radar has an effective range from 200 ft to 24 nm and has an operating power consumption of 18 W and stand-by power consumption of 2 W.

The system consists of: radar scanner (1), an RI10 interface box (3) (not included in USA model) and an interconnection cable (2). The scanner is housed in a dome of similar size to most 2 kW radars on the market.

The RI10 interface box is used to connect displays, power and heading information if MARPA or chart over lay are required (Heading sensor not included). The RI10 has a SimNet (Simrad NMEA 2000) connector for heading input. The RI10 is included in all kits except Lowrance USA model (000-10418-001)

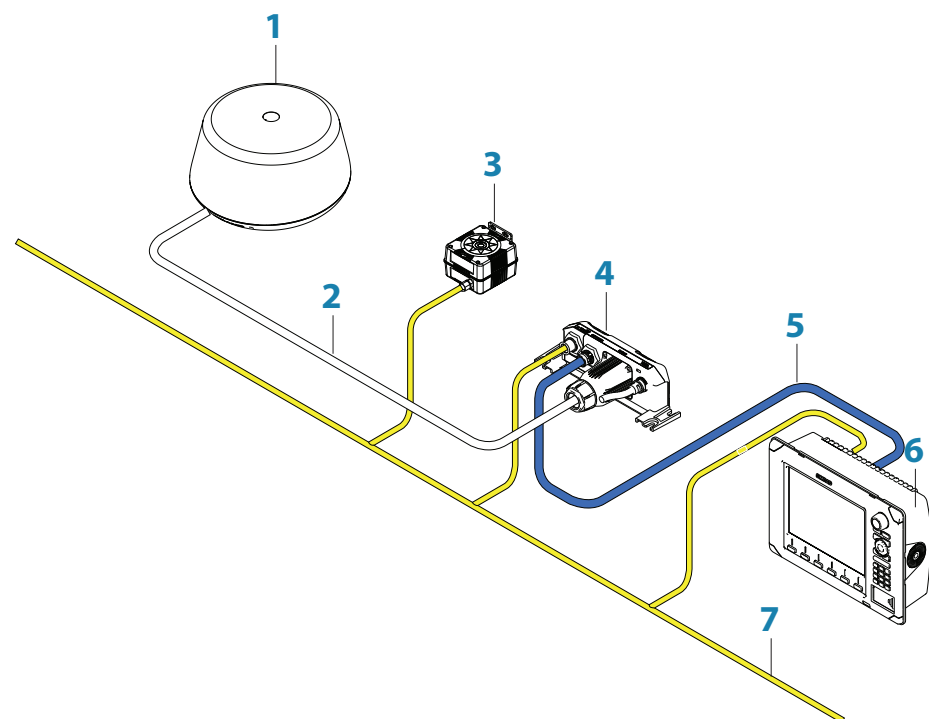

1. 3G Radar
2. Radar interconnection cable
3. Option heading sensor required for MARPA and chart overlay (not included)
4. RI10 Radar interface box (not included in USA model)
5. Ethernet cable. ships with a 1.8 m (6 ft)
6. Display: Simrad NSO, NSE or NSS / B&G Zeus / Lowrance HDS
7. SimNet or NMEA2000 data network (not included)

Please take a moment and check the separate packing list to make sure all components have been supplied

Display	Kit Part Number	Broadband 3G™ Radar	RI10 AA010189	Interconnect cable	Ethernet cable 1.8 m (6ft)	RJ45-5Pin Ethernet Adapter 2m (6.6 ft) 000-0127-56
Lowrance HDS USA	000-10418-001	✓	✗	10 m (33 Ft) AA010211	✗	✓
Lowrance HDS ROW	000-10435-001	✓	✓	10 m (33 Ft) AA010211	✓	✗
Simrad NSO, NSE, NSS	000-10420-001	✓	✓	20 m (65 ft) AA010212	✓	✗
B&G Zeus	000-10422-001	✓	✓	20 m (65ft) AA010212	✓	✗
				Note: Optional 30 m (98 ft) cable available AA010213		

3

Installation

→ **Note:** Follow these instructions carefully. Don't take any shortcuts!

The broadband radar is factory sealed. It is not necessary to remove the cover. Removing the cover will void the factory warranty.

Tools Required

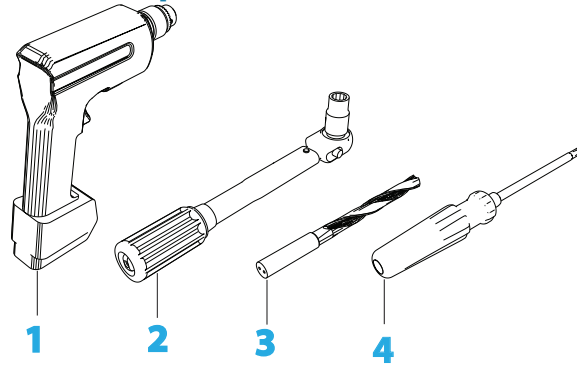

1. Drill
2. Torque wrench
3. Drill bit 9.5 mm (3/8")
4. Screw driver

Choose the scanner location

The radar's ability to detect targets greatly depends on the position of its scanner. The ideal location for the scanner is high above the vessel's keel line where there are no obstacles.

A higher installation position increases the radar ranging distance, but it also increases the minimum range around the vessel where targets cannot be detected.

When you're deciding on the location, consider the following:

The length of the interconnection cable supplied with your radar is usually sufficient. If you think you'll need a longer cable, consult your dealer before installation. Optional cable lengths are 10 m (33 ft), 20 m (65.5 ft) and 30 m (98 ft).

If you mount the scanner on a pedestal or base, ensure that rain and sea spray can drain away rapidly, and the breather hole in the base can operate.

The scanner is usually installed parallel to the line of the keel.

DON'T DO THIS!

DON'T install the scanner too high up, which may cause degradation of the radar picture over short ranges.

DON'T install the scanner close to lamps or exhaust outlets. The heat emissions may damage the dome. Soot and smoke will degrade the performance of the radar.

DON'T install the scanner close to the antennas of other equipment such as direction finders, VHF antennas, GPS equipment as it may cause interference.

DON'T install the scanner where a large obstruction (such as an exhaust stack) is at the same level as the beam, because the obstruction is likely to generate false echoes and/or shadow zones.

DON'T install the scanner where it will be subjected to strong vibrations because these vibrations could degrade the performance of the radar.

DON'T install the scanner such that boat electronics with switch mode power supplies (such as fish-finders and chart plotters) are in the beam of the antenna.

DON'T install the scanner directly on to a large flat roof area. Use a pedestal to elevate the scanner for radar beams to clear roof line (see "Considerations for direct roof mounting" on page 11)

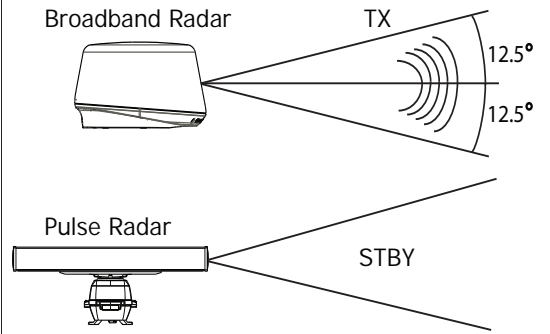
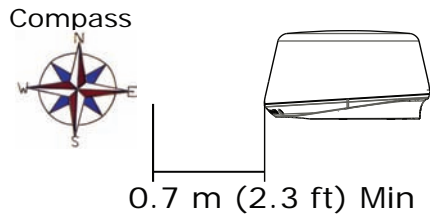

Minimum distance to install near the ships compass is 0.7 m (3.3 ft).

It is recommended not to install the scanner on the same beam plane as a conventional pulse radar. A pulse radar must be set to STBY or OFF when the 3G™ is being operated.

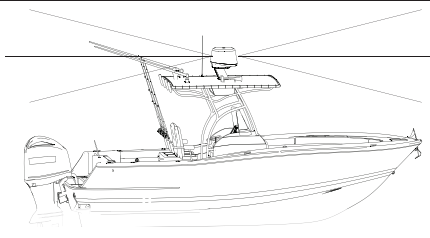

If possible ensure that the location site provides the scanner with a clear view all round the vessel.

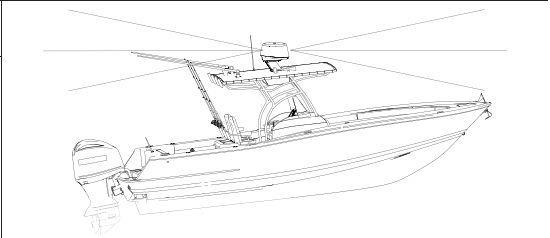

Installations on power boats that have a steep planing angle, it is recommended to tilt the scanner angle down at the front. (Beam angle is 12.5° either side of center).

Considerations for direct roof mounting

When deciding a suitable mounting location for the 3G™ scanner, be aware that the vertical radar beam extends to 25° either side of horizontal. With 50% of the power projecting in a beam 12.5° off horizontal. If the radar beams cannot clear the roof lines this could decrease performance of the radar. Depending on the size of the hard top of the vessel it is recommended not to mount directly on to the surface, instead elevate the scanner to allow the radar beams to clear the roof lines. Below are guide lines on heights above the hard top

Possible performance loss

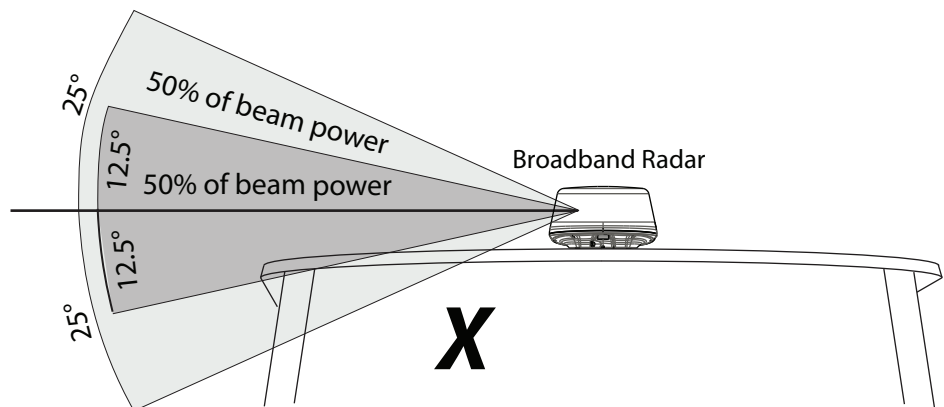

Above illustrates an installation with the Broadband 3G™ radar mounted directly on to a large hard top. This installation could suffer decreased performance as the radar energy is either reflected or absorbed by the hard top.

Better performance

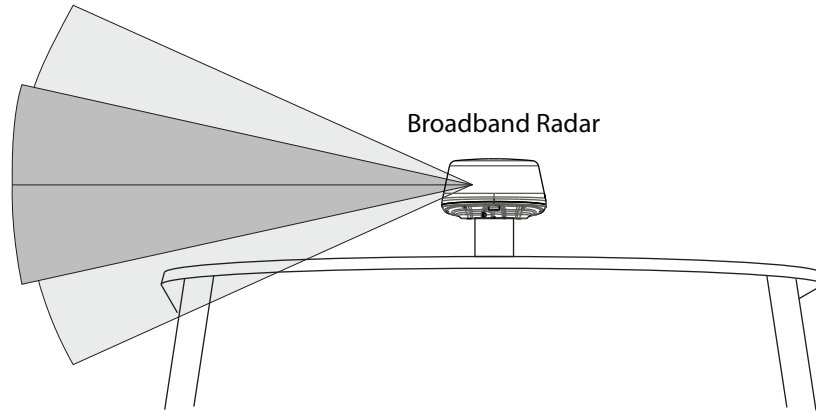

Above illustrates that raising the 3G scanner off the hard top allowing most of the radar energy to clear the hard top.

Best performance

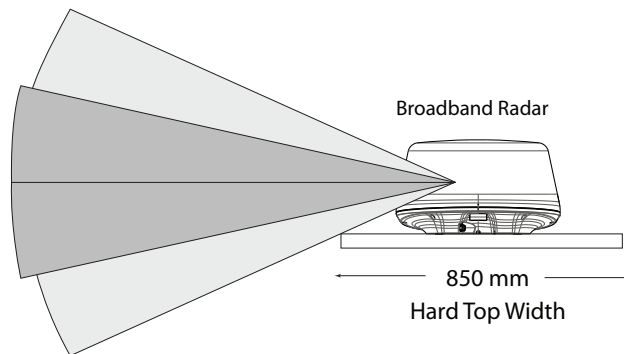

For best performance, the radar should be positioned to allow the beams to clear the superstructure of the boat

Below is a guide to determine scanner height in relation to a vessels hard top overall width.

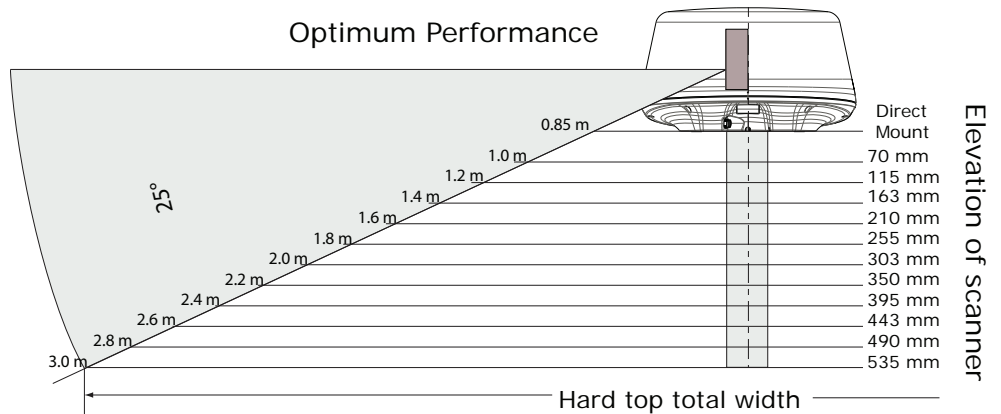

Every Increase of 400 mm of hard top width over 1.0 m wide: Increase height by 140 mm

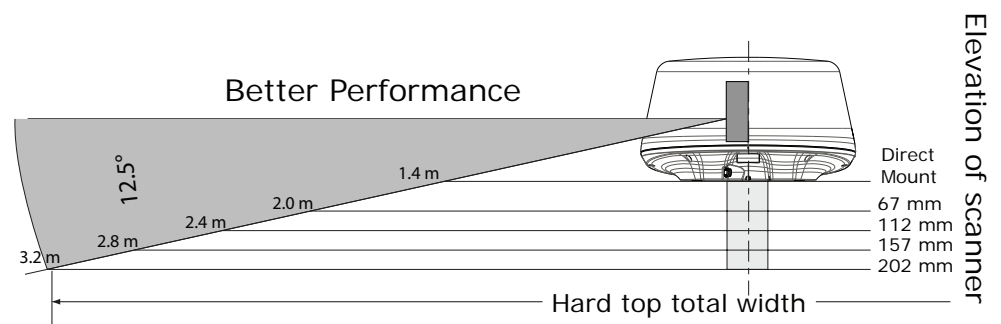

Every increase of 400 mm of hard top width over 2.0 m wide: Increase height by 45 mm

Mounting the scanner

Use the supplied mounting template and tape it securely to the chosen location site.

Before drilling, check that:

- you have oriented the mounting template correctly so that the front of the scanner unit will face the front of the vessel
- the location site is not more than 18 mm (0.7") thick. If the location site is thicker use longer bolts
- the four bolts supplied are M8 x 30 mm. If you need to use longer bolts make sure they are marine grade stainless steel and allow for minimum of 8 mm (0.3") and maximum of 18 mm (0.7") of thread contact.

1. Use a 9.5 mm (3/8") drill bit to drill the four holes where shown on the mounting template.
 2. Remove the mounting template.
 3. Connect the scanner interconnection cable (see "Connect interconnection cable to the scanner" on page 14)
 4. Route the connection cable through the cable retention channel.
 5. Position the scanner carefully over the bolt holes so that they are aligned.
 6. Place a lock washer and a plain washer onto each bolt, as shown.
 7. Insert bolt into drill hole and locate into scanner's threaded mounting holes and tighten securely.
- **Note:** The torque settings for the mounting bolts are 12 Nm – 18 Nm (8.9 lb ft – 13.3 lb ft)

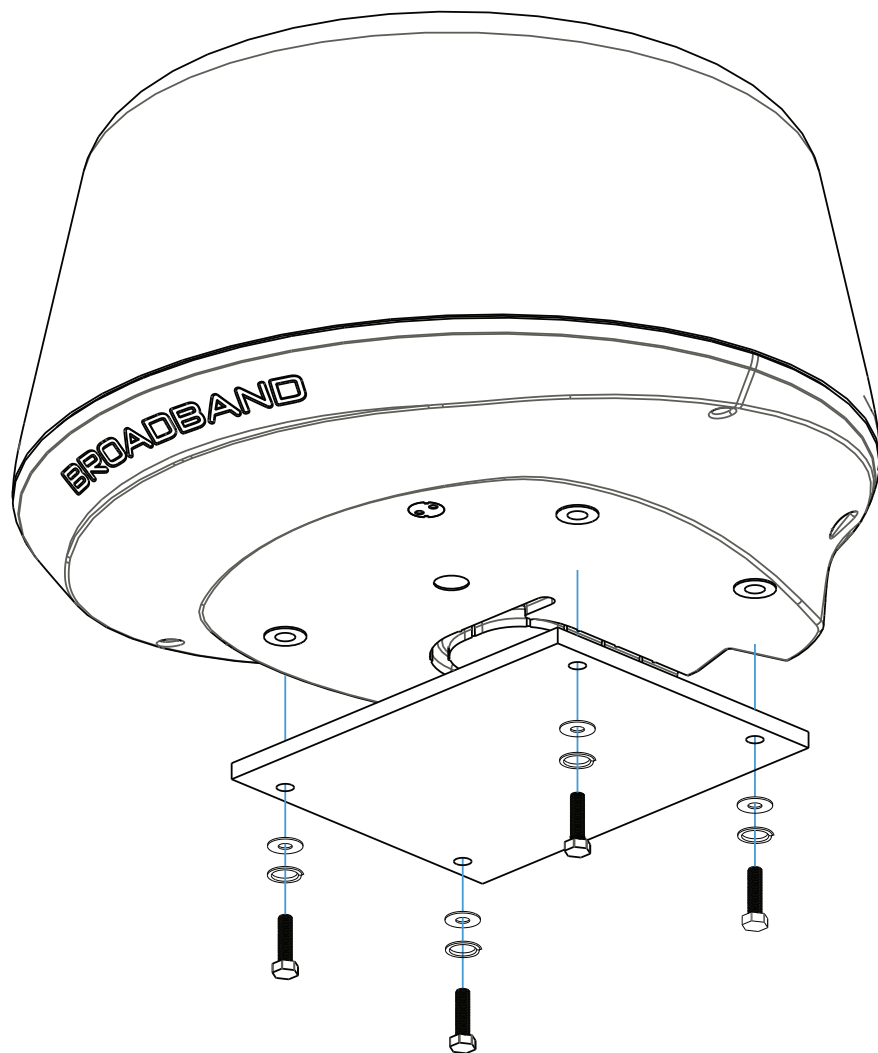

Connect interconnection cable to the scanner

The scanner interconnection cable connects the scanner to the RI10 interface box (or Lowrance HDS via and ethernet adapter cable -U.S only). The cable connects to the scanner using a 14 pin connector.

Protect the connectors when pulling cable through the boat and avoid putting strain on to the connectors.

The interconnection cable is 9 mm in diameter. A 14 mm hole will be required in order for the RJ45 connector to pass through (Interface box end) or 24 mm for the scanner end connector.

Run the interconnection cable between the scanner and the location of the radar interface box.



Insert cable connector on to the male 14 pin plug on the scanner.

Take care to align the connector correctly to avoid bending the pins. Secure the locking collar by rotating clockwise until it clicks.

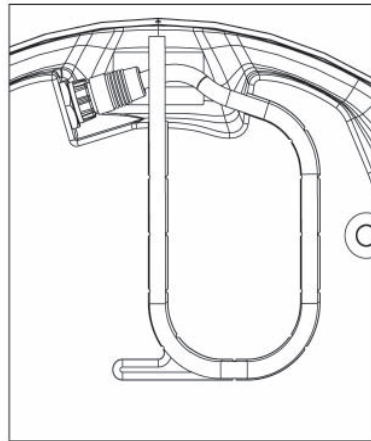
Feed and secure the cable into the cable retention channel.

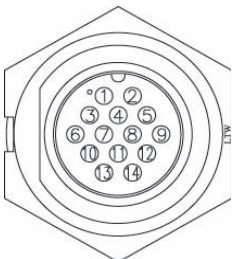

Scanner Interconnection cable pin out

		Pin-out		
		Conn	Wire color	RJ45
 <p>Scanner connector</p>	 <p>Cable connector Diameter = 23 mm</p>	1	Black	Tinned wire
		2	Red	Tinned wire
		3	Yellow	Tinned wire
		4	Drain	Tinned wire
		5	N/A	N/A
		6	Blue	RJ45 Pin 4
		7	White / Blue	RJ45 Pin 5
		8	White / Brown	RJ45 Pin 7
		9	Brown	RJ45 Pin 8
		10	White / Green	RJ45 Pin 3
		11	N/A	N/A
		12	White / Orange	RJ45 Pin 1
		13	Green	RJ45 Pin 6
		14	Orange	RJ45 Pin 2

Connect the interconnection cable to radar interface box

To connect interconnection cable to Lowrance HDS (USA only) (see "Lowrance HDS USA" on page 17)

<p>1. Slide (F), (E) and (D) over the RJ45 and data wires of the scanner interconnection cable (G).</p>	<p>2. Connect data wires to the phoenix connector.</p> <p>3. Connect RJ45 and phoenix connector to the radar interface box.</p>																		
<p>4. Secure (D) to the radar interface box using the four supplied screws (H).</p>	<p>5. Slide (E) along the cable (G) and press into the cable gland housing (D).</p>																		
	<table border="1"> <thead> <tr> <th>Key</th> <th>Description</th> </tr> </thead> <tbody> <tr> <td>A</td> <td>Radar interface box</td> </tr> <tr> <td>B</td> <td>Radar data connector RJ45</td> </tr> <tr> <td>C</td> <td>Power wires (see "Connect power" on page 21)</td> </tr> <tr> <td>D</td> <td>Cable gland housing</td> </tr> <tr> <td>E</td> <td>Gland washer</td> </tr> <tr> <td>F</td> <td>Lock nut</td> </tr> <tr> <td>G</td> <td>scanner interconnection cable</td> </tr> <tr> <td>H</td> <td>Screws x 4 M3x12 mm Phillips pan head</td> </tr> </tbody> </table>	Key	Description	A	Radar interface box	B	Radar data connector RJ45	C	Power wires (see "Connect power" on page 21)	D	Cable gland housing	E	Gland washer	F	Lock nut	G	scanner interconnection cable	H	Screws x 4 M3x12 mm Phillips pan head
Key	Description																		
A	Radar interface box																		
B	Radar data connector RJ45																		
C	Power wires (see "Connect power" on page 21)																		
D	Cable gland housing																		
E	Gland washer																		
F	Lock nut																		
G	scanner interconnection cable																		
H	Screws x 4 M3x12 mm Phillips pan head																		
<p>6. Rotate (F) clockwise to secure.</p>																			

To remove the scanner interconnection cable, follow the above procedure in reverse order.

To avoid damaging the connectors when removing the scanner interconnection cable, it is important to remove the cable gland washer before trying to remove the cable gland housing.

Shortening the cable

It is not recommended to shorten the cable, but if it is essential, use the pin-out below to re-terminate the RJ45 connector

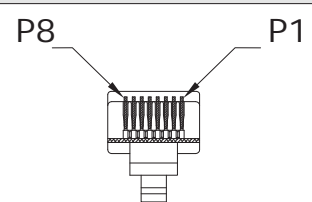
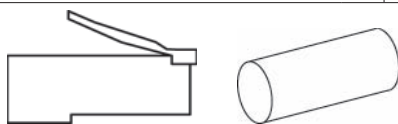
RJ45 Connector		
RJ45 crimping tool is required	Pin	Color
	1	White/Orange
	2	Orange
	3	White/Green
	4	Blue
	5	White/Blue
	6	Green
	7	White/Brown
	8	Brown
		
RJ45 Connector		15 mm Heat shrink (10 mm dia)

Mounting the radar interface box

Install the radar interface box (where applicable) in a dry location away from spray, rain, drips and condensation.

The radar interface box must be located where it can be easily connected to the ship's power source, the scanner interconnection cable, SimNet/NMEA2000 and the display or display network.

Allow enough room for cables to form a drip loop.

Preferably mount the radar interface box on a vertical surface with cables exiting downwards.

Insert connectors. See "Connect the interconnection cable to radar interface box" on page 15.

Secure to the surface using the four mounting points.

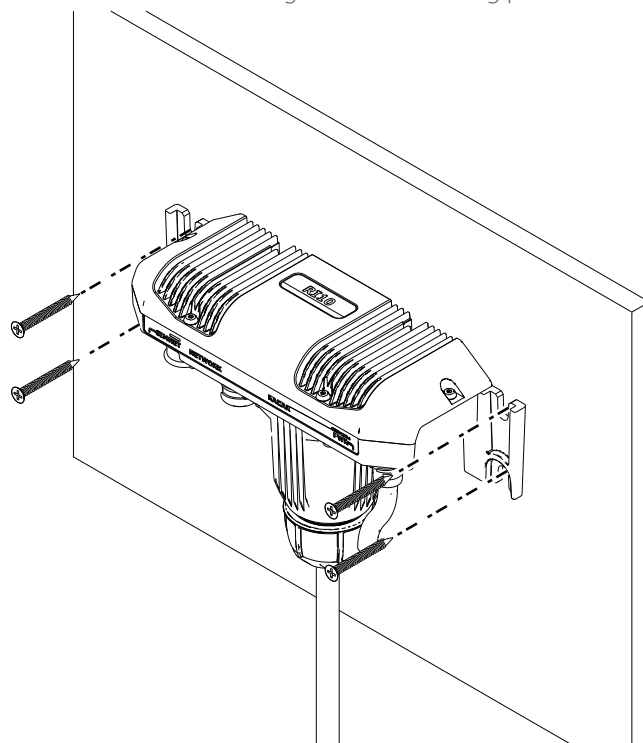

4

Connect the Broadband radar to your display

Lowrance HDS USA

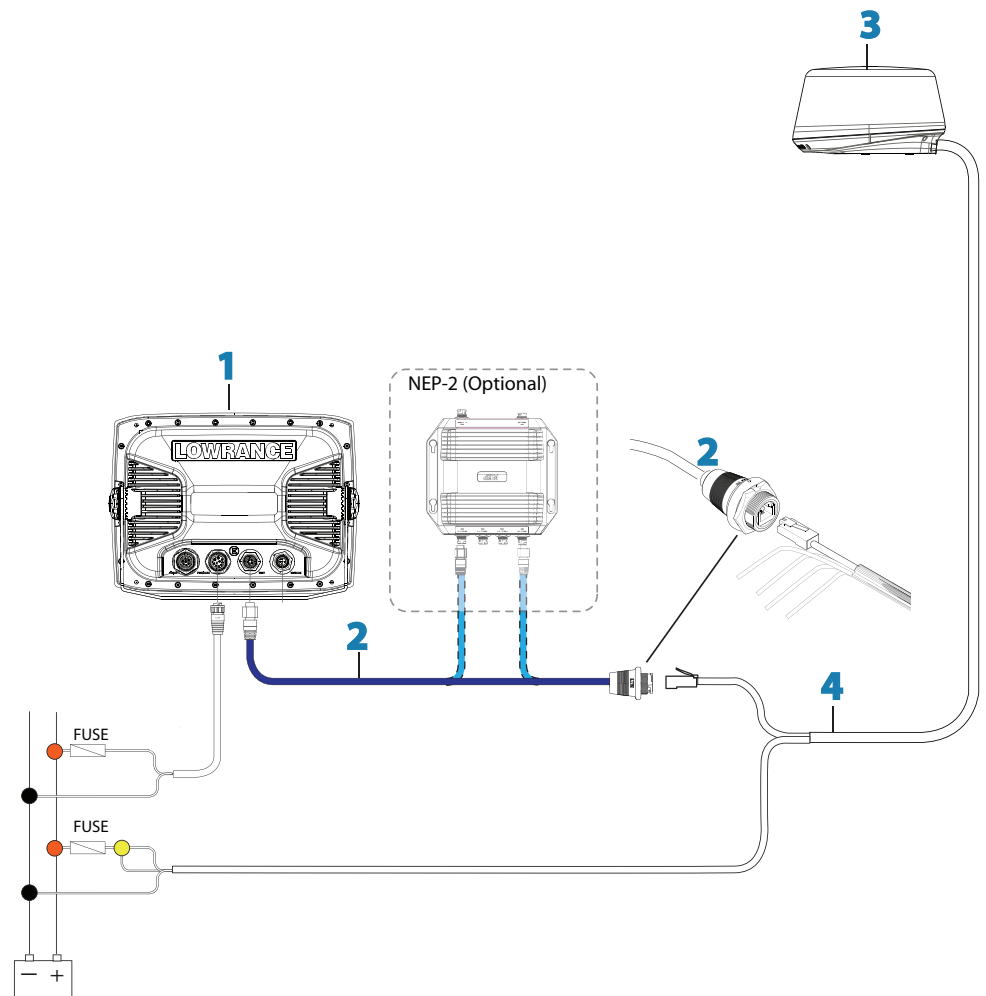

1. Lowrance HDS
2. Ethernet adapter cable. 5 pin yellow male to RJ45 female 1.8 ft (6ft). Included in 000-10418-001 3G™ kit
Can connect directly to the HDS, via a NEP-2 Ethernet switch or using a free Ethernet port on a LSS-1 Structure Scan module (if applicable)

→ **Note:** Make sure this connection is made in a dry environment and is secured properly

3. 3G™ Radar
4. Interconnection cable. Ships with a 10 m (33 ft) : Optional 20 m (65 ft) and 30 m (98 ft) available

Lowrance HDS Outside USA or with MARPA / Chart overlay

Simrad NSS (NMEA2000 network)

The 3G™ Radar connects to the Lowrance HDS and Simrad NSS in the same manner

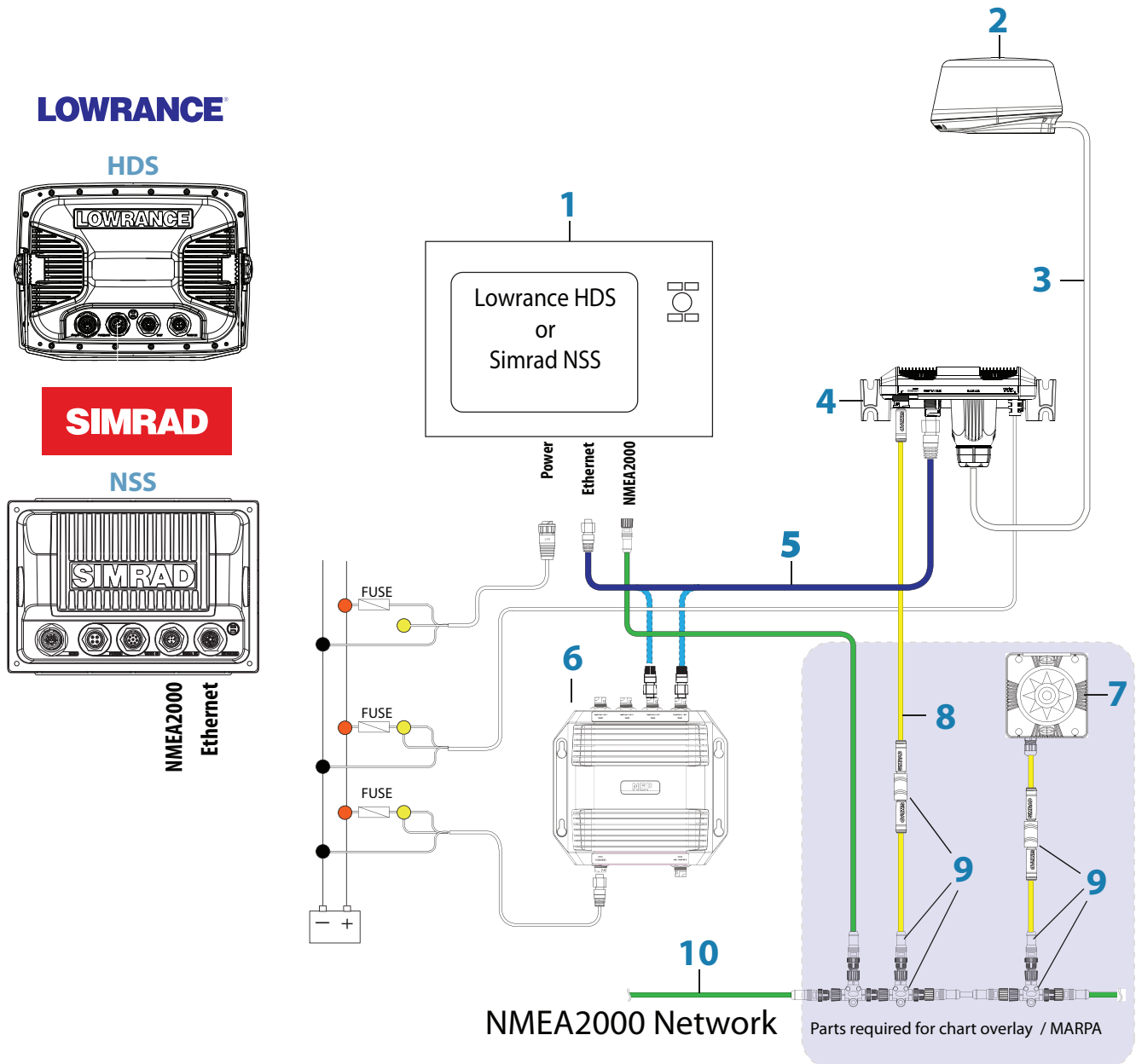

1. Multifunction Display
 2. Broadband 3G™ scanner
 3. Interconnection cable (Lowrance 10 m (33 Ft) Simrad 20 m (65.5 ft))
 4. RI10 Radar interface box
 5. Ethernet cable 1.8 m (6 ft) For more cable lengths see "Ethernet cables" on page 29. The RI10 can connect either directly to a Multifunction display or via a Ethernet switch (NEP-2) or a free port on an LSS-1 Structure scan module
 6. NEP-2 Network Expansion Port. 5 Port Ethernet switch
- The following Parts required for chart overlay and MARPA**
7. RC42 Heading Sensor
 8. SimNet cable. For cable options see "SimNet cables" on page 29
 9. SimNet - NMEA2000 adapter kit: a) SimNet -Micro-C cable 0.5 m (1.6 ft), b) SimNet joiner. c) NMEA2000 T-Connector

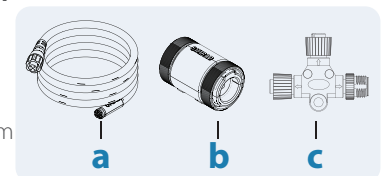

B&G Zeus

Simrad NSO, NSE and NSS, (SimNet network)

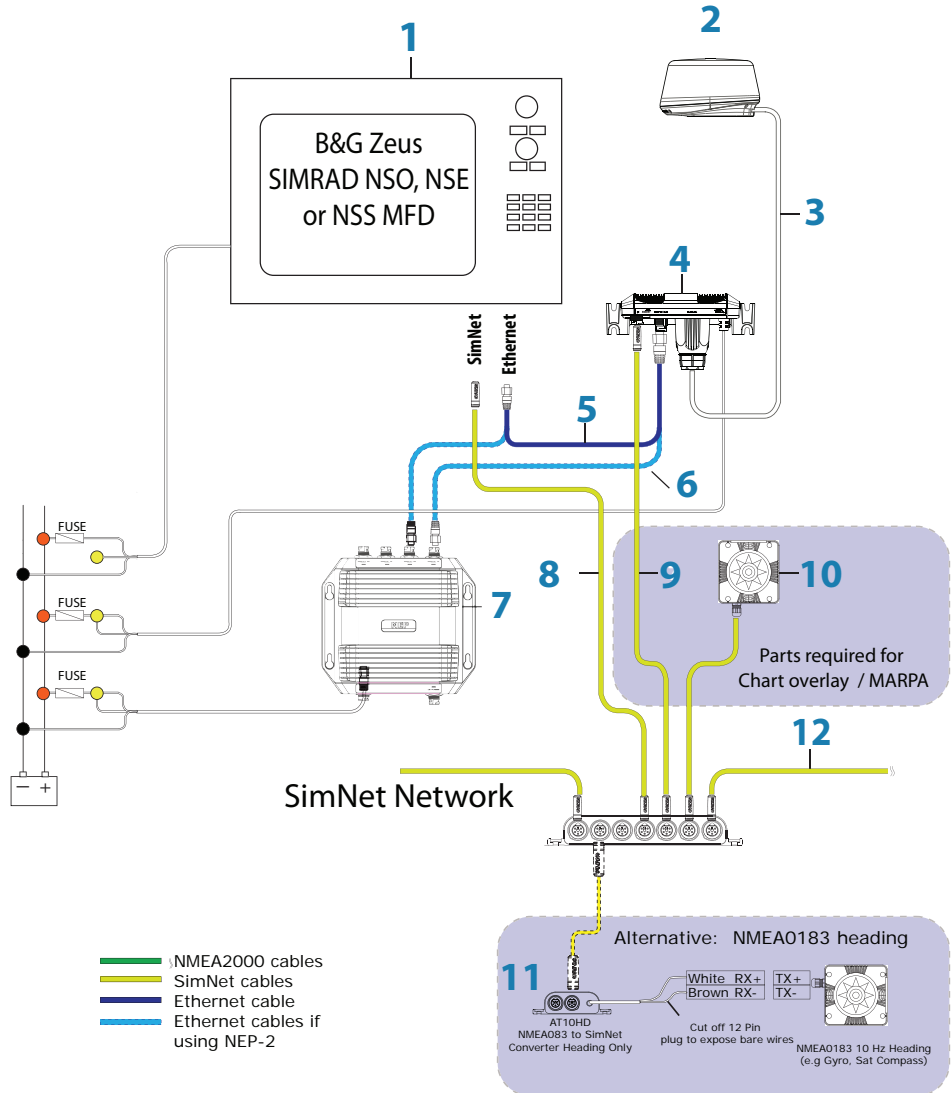
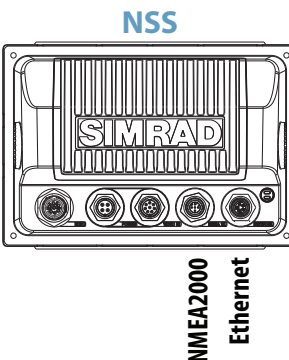
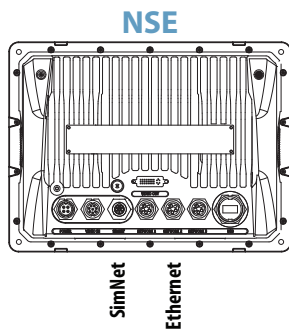
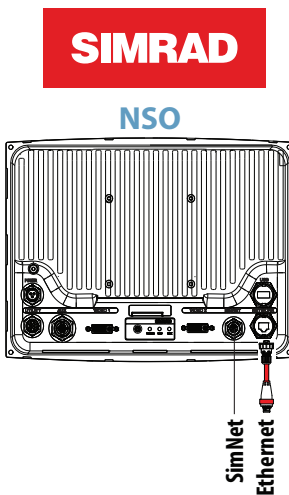
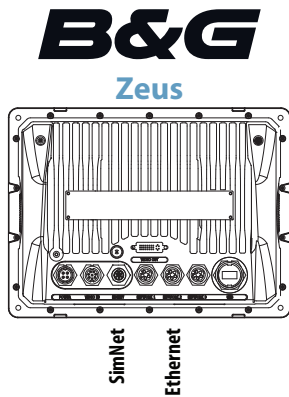

- B&G Zeus or Simrad NSO / NSE / NSS
 - Broadband 3G™ Scanner
 - Interconnection cable. Ships with a 20 m (65 ft) : Optional 10 m (33 ft) and 30 m (98 ft)
 - RI10 Radar interface box
 - Ethernet cable. 3G™ ships with a 1.8 m (6 ft) cable. The 3G™ can be connected directly to the NETWORK port of the display/processor box, or via a Network Expansion Port (9) extra Ethernet cables required (7). "Ethernet cables" on page 29 for part numbers
 - Ethernet cables required to connect 3G™ via a NEP-2 (9)
 - Ethernet switch NEP-2 (000-0132-031)
 - For B&G Zeus, Simrad NSE, NSO . SimNet cable. (Not supplied)
For SimRad NSS. SimNet to Micro-C cable (Not supplied) see "SimNet - NMEA2000 adapter cables" on page 29
 - SimNet drop cable. Allows display to receive heading information for chart overlay
 - RC42 Heading Sensor (22090195)
 - AT10HD. For installations with a NMEA0183 heading sensor AT10HD converts NMEA0183 to SimNet / NMEA2000 (Only heading information is converted)
 - SimNet Network
- The following Parts required for chart overlay and MARPA

5

RI10 Connections

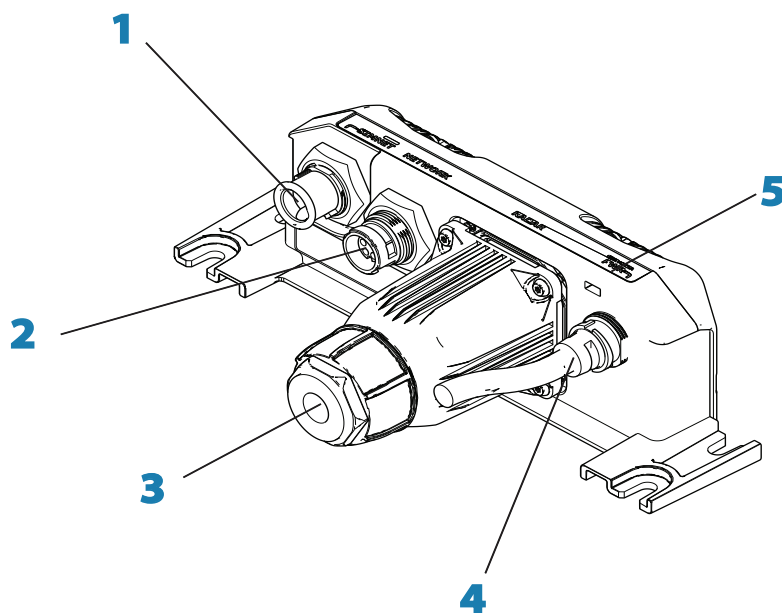

1. SIMNET:

Connects the RI10 to a SimNet or NMEA2000 network to allow heading and position information to be sent to the scanner for MARPA calculations

Lowrance HDS units sold in the USA do not require an interface box and the scanner connects directly to the display or Ethernet switch. If chart overlay or MARPA are required for Lowrance HDS USA then an RI10 Interface box and heading sensor are required.

→ **Note:** For Chart overlay and MARPA it is essential to use a heading sensor with an output speed of 10 Hz. Heading sensor needs to be a rate gyro stabilized compass or better.

2. NETWORK:

Main data interface between the radar and the display.

3. INTERCONNECT CABLE:

Provides connection between the 3G™ radar dome and the RI10.

4. POWER:

Power cable (see "Connect power" on page 21).

5. LED Indicator:

Green LED indicating power is supplied to the RI10.

6

Connect power

The Broadband radar can operate on 12 or 24 V DC systems. The Broadband radar requires a +V DC to be applied on the yellow power on wire in order to operate. This can be achieved in one of three ways:

- Common the red and yellow wire together. Radar will power on when power is applied
- Use ignition or install a switch that will provide power to the yellow wire. (It is recommended to use a 5 amp fuse or breaker). The radar will turn on when switch is activated
- Connect the yellow wire to external wake up of suitable display. The radar will turn on when the display is turned on

Before connecting power to the system:



make sure the scanner has been installed and is secured.



make sure the radar interconnection cable is connected to the radar.



if using the Radar Interface Box make sure all connections have been made to the display.

For systems using an RI10 radar interface box

Connect the red wire to power positive 12 or 24 V DC. Use a 5 amp fuse or breaker. Connect the yellow wire to power source that will turn on the system (see above). Connect black to power negative.

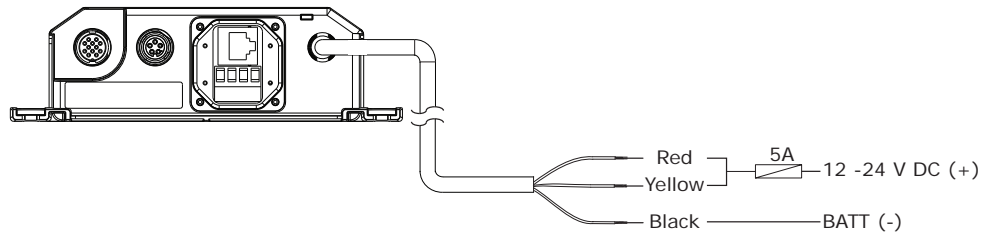

For systems not using radar interface box (Lowrance HDS USA only)

Connect the red wire to power positive 12 or 24 V DC. Use a 5 Amp fuse. Connect the yellow wire to power source that will turn on the system (see above). Connect black to power negative.

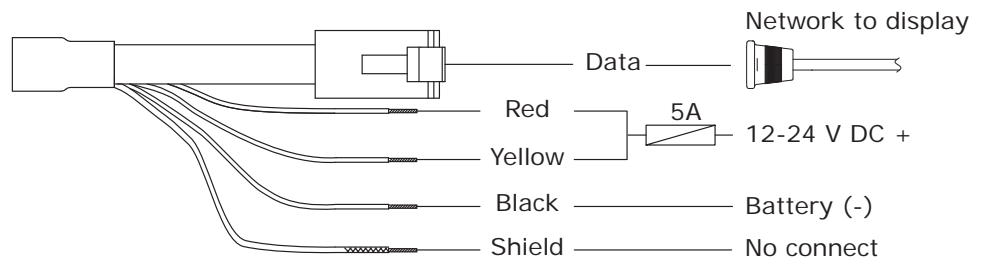

Alternate method to connect yellow wire and control power state of the radar		
Not connected	Fused DC (or with switch)	Tied to display yellow wire HDS, NSS, NSE, Zeus (not NSO)
Radar will not function	Radar will turn on when power is applied (or when switch is turned on)	Radar will turn on and off with the display. → Note: Zeus NSE, NSS display will need to be set as power control master

7

Setup and Configuration

Setup and configuration of the Broadband radar has been simplified compared to traditional pulse radars. There is no zero range adjustment (time delay), no warm up time, and no burn in required.

The only adjustments really needed are:

Entering radar setup on your display

Enter radar installation by pressing MENU > SETTINGS > RADAR > INSTALLATION.



Radar Status

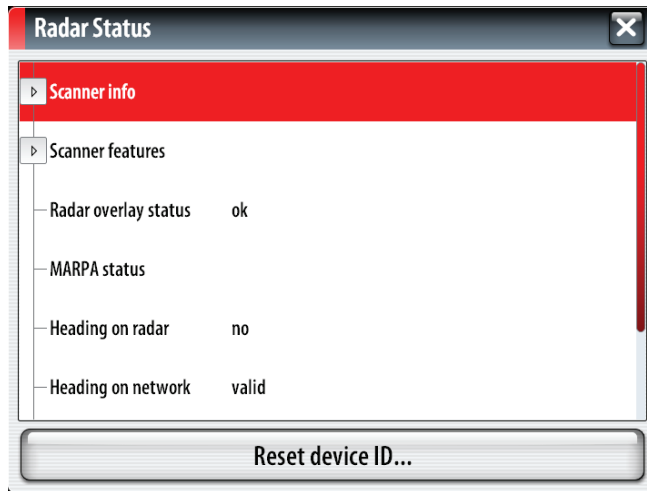

Software version

Check to make sure you have the latest software. Check website for the latest version

Serial Number

Take a minute to write down the serial number of the radar

MARPA Status

The MARPA status can identify if a heading sensor is on the network and that the radar is receiving heading information essential for MARPA calculations

Reset device ID

NSS and HDS displays only support one radar on the network. Should a radar be connected, that has been previously connected to a dual radar network in the past, it may not be detected by the display because it has an incorrect Device ID. To resolve this problem use the following procedure, which must be performed with only one radar on the network.

From the Radar Installation page. Select "Reset device ID..." then follow the on screen prompts

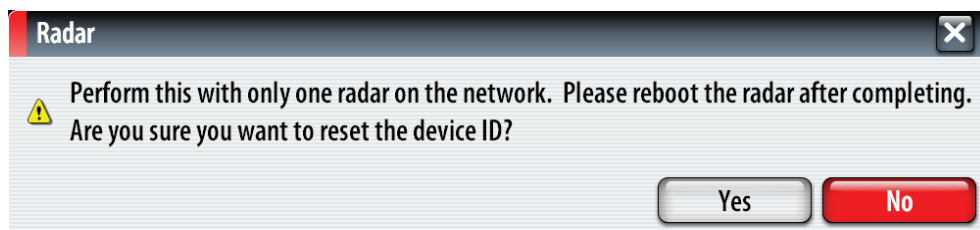

Adjust bearing alignment...

Adjust the heading marker. This is to align with the heading marker on the screen with the center line of the vessel, this will compensate for any slight misalignment of the scanner during installation. Any inaccuracy will be evident when using MARPA or chart overlay.

Point the boat to the end of a head land or peninsular. Adjust the bearing alignment so the heading line touches the end of the same head land or peninsular.

Adjust local interference reject...

Interference from some onboard sources can interfere with the Broadband radar. One symptom of this could be a large target on the screen that remains in the same relative bearing even if the vessel changes direction. Choose from Local interference rejection LOW, MED or HIGH. Default is LOW

Adjust antenna height...

Set the radar scanner height. The Radar uses this value to optimize sea clutter performance

Sidelobe suppression...

→ **Note:** This control should only be adjusted by experienced radar users. Target loss in harbour environments may occur if this control is not adjusted correctly.

Occasionally false target returns can occur adjacent to strong target returns such as large ships or container ports. This occurs because not all of the transmitted radar energy can be focused into a single beam by the radar antenna, a small amount of energy is transmitted in other directions. This energy is referred to as sidelobe energy and occurs in all radar systems. The returns caused by sidelobes tend to appear as arcs:

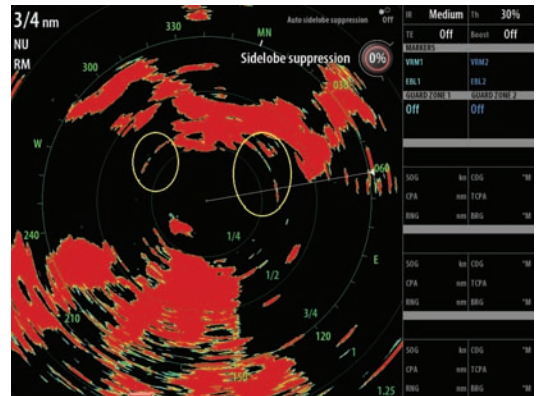

When the radar is mounted where there are metallic objects near the radar, sidelobe energy increases because the beam focus is degraded. The increased sidelobe returns can be eliminated using the Sidelobe Suppression control in the Radar installation menu.

By default this control is set to Auto and normally should not need to be adjusted. However if there is significant metallic clutter around the radar, sidelobe suppression may need to be increased. The control should be adjusted as follows:

1. Set Radar range to between 1/2nm to 1nm and Sidelobe Suppression to Auto.
2. Take the vessel to a location where sidelobe returns are likely to be seen. Typically this would be near a large ship, container port, or metal bridge
3. Traverse the area until the strongest sidelobe returns are seen.
4. Change Auto sidelobe suppression to OFF then select and adjust the sidelobe suppression control until the sidelobe returns are just eliminated. You may need to monitor 5-10 radar sweeps to be sure they have been eliminated.
5. Traverse the area again and readjust if sidelobes returns still occur.
6. Exit the installation menu.

To start the radar:

.From the radar screen select the Transmit button.

RI10 heading source selection:

The RI10 receives heading via SimNet or NMEA2000 network and transmits this data to the radar, where MARPA processing is performed.

For Simrad installations with more than one SimNet heading source the RI-10 will use the Simrad group source. The source used by the Simrad group can be viewed or changed via an NSx display in the Settings>Network>Sources... menu:

Dual radar setup:

For B&G Zeus and Simrad NSO and NSE displays it is possible for two radars to be connected to the network and viewed simultaneously on one display. At time of installation radar source selection needs to be performed as described below.

1. Power up the system including all radars. (max. two radars)
2. On any display - the first radar ever detected by the display will be used as the source for all chart and radar panels. This source will be used by default for every system that power up thereafter until changed.

The radar source is identified by radar type with a four digit number and is displayed in the top left corner of chart and radar panels:

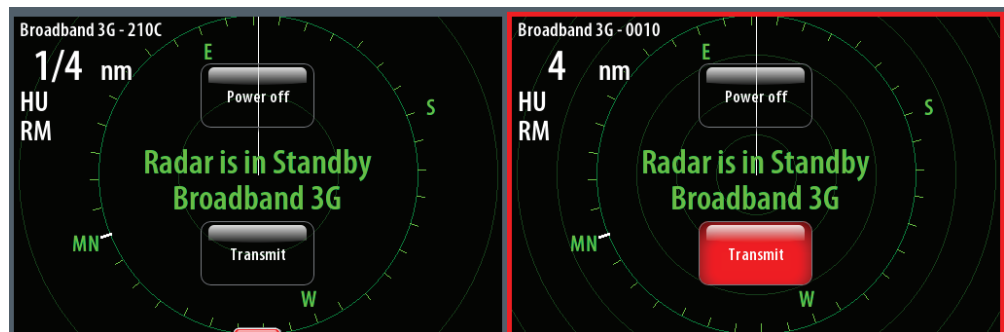

The four digit number is the last four digits of the radars serial number.

3. For a radar panel, the radar source can be changed in the Radar>Radar Options>Sources menu:
4. For a chart panel (with radar overlay on), the radar source can be changed in the Chart>Radar Options>Sources menu:

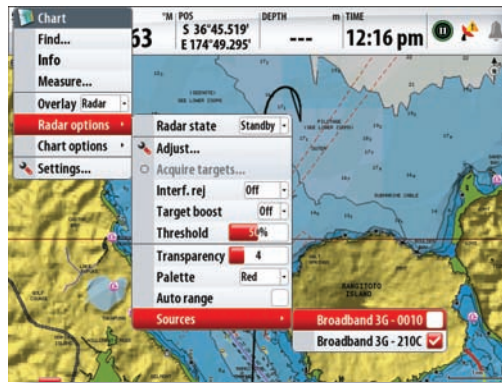

- For pages with more than one radar or chart panel, it is possible to set up difference radar sources for each panel.

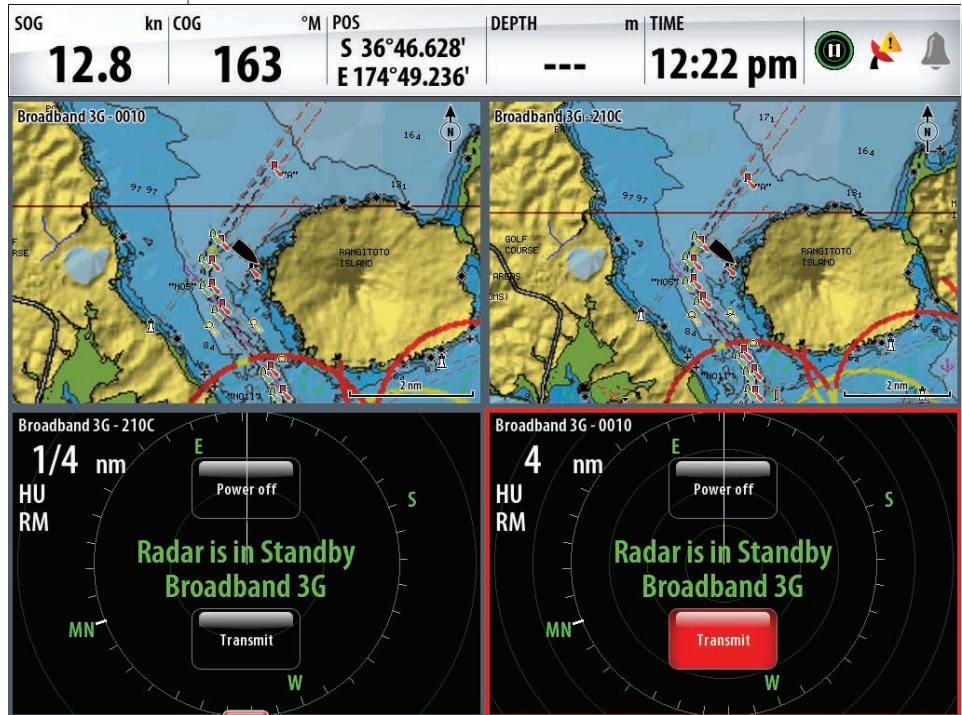

- The radar source selection is not global, so will only apply to the display on which the source was selected. The radar source will need to be setup for each display on the network.

Once the radar sources have been set up they will be retained for every system until changed.

8

Dimension Drawings

Scanner

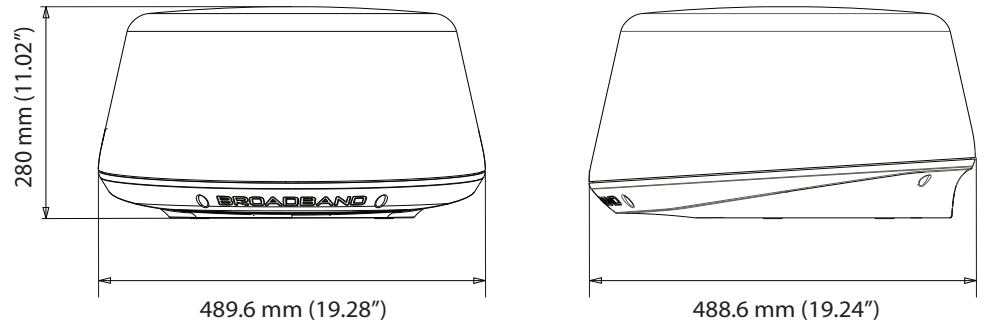

FRONT

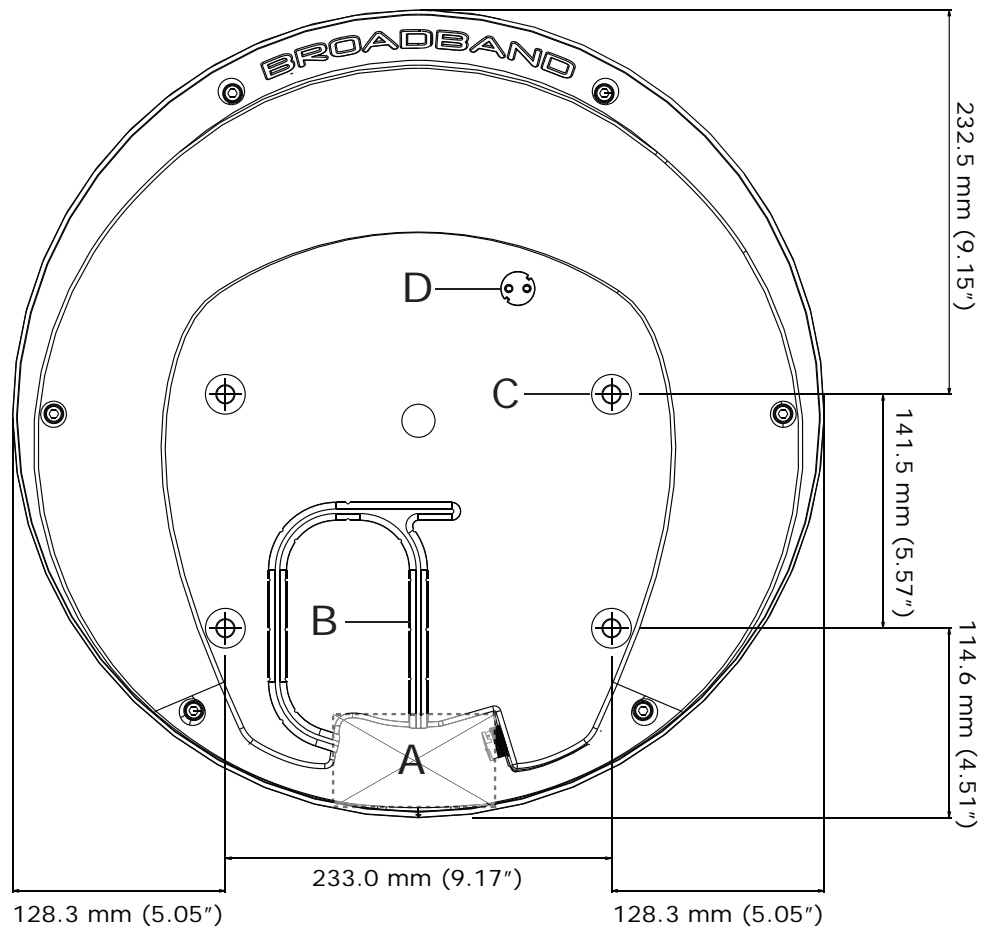

Key	Description
A	Cable entry area
B	Cable retention channel
C	Bolt holes x 4 M8 x 30 mm
D	Breather

Radar interface box

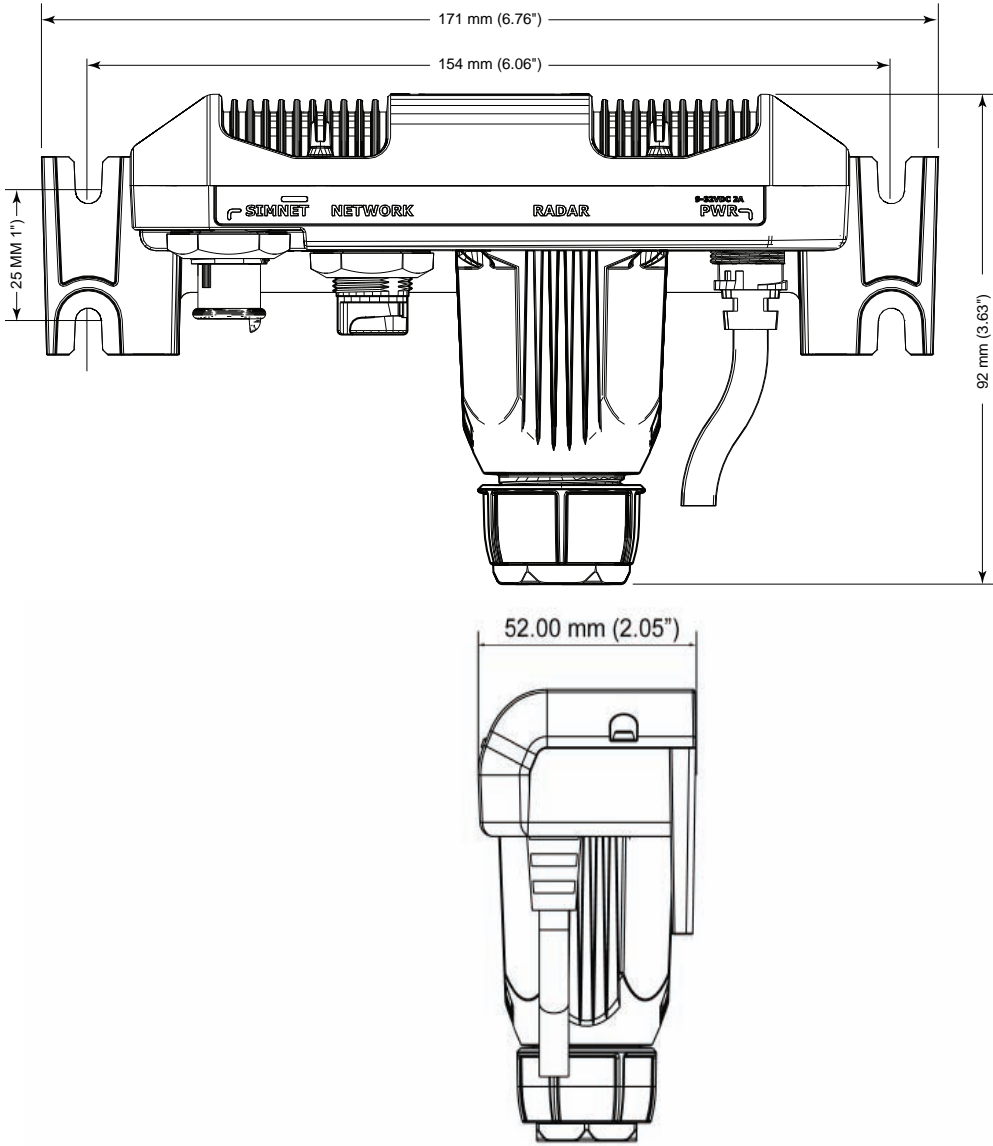

9

Maintenance

Clean the radome using soapy water and a soft cloth. Avoid using abrasive cleaning products. Do not use solvents such as gasoline, acetone, M.E.K etc. as this will damage the dome surface.

After years of use the drive belt may have to be replaced.

Transmitter is solid state and will not require regular replacement as with an ordinary magnetron.

10

Specifications

Characteristic	Technical Data	
Compliance	CE, FCC (ID: RAY3G4G), IC: 4697A-3G4G	
Environmental	IEC60945 4th edition 2002-2008 Operating Temperature: -25° to +55°C (-13° to +130°F) Relative humidity: +35° C (95° F), 95% RH Waterproof: IPX6	
Relative wind velocity	51 m/sec (Max:100 Knots)	
Power consumption (with 10m cable)	Operating: 18W (Typ.) @ 13.8Vdc Standby: 2W (Typ.) @ 13.8Vdc ~ 150mA	
DC input (at end of radar cable)	9V to 31.2Vdc (12/24 Volt systems). Reverse polarity protection	
Transmitter source (pre-heating time)	No magnetron – Instant On™	
Outside dimensions	Height 280 mm x Diameter 489 mm (Height 11" x Diameter 19.3")	
Scanner weight (no cable)	7.4 kg (16.31 lbs)	
Radar and Antenna Parameters		
Radar ranges	50 m (200 ft) to 24 nm with 17 range settings (nm/sm/km)	
Rotation (mode dependent)	24/36 rpm +/-10%	
Transmitter frequency	X-band - 9.3 to 9.4 Ghz	
Transmitter source (warm-up time)	No Magnetron – all solid state. Instant On™	
Plane of polarization	Horizontal Polarization	
Transmitter peak power output	165 mW (nominal)	
Main bang dead zone & tuning	None – not a pulse radar	
Sea and rain clutter	5X less than a pulse radar	
Sweep repetition frequency	200 Hz	
Sweep time	1.3 ms+/- 10%	
Sweep bandwidth	75 MHz max	
Horizontal beam width (Tx and Rx antenna)	5.2° +/-10% (-3 dB width)	
Vertical beam width (Tx and Rx antenna)	25° +/-20% (-3 dB width)	
Side lobe level (Tx and Rx antenna)	Below -18 dB (within ±10°); Below -24 dB (outside ±10°)	
Noise figure	Less than 6 dB	
Coms/Cabling/Mounting		
Com protocol	High Speed Ethernet	
Heading	NMEA2000 / SimNet with RI10 interface box	
Inter connecting cable length	Lowrance 10 m (33 ft) Simrad, B&G 20 m (65.6 ft)	
Maximum inter connecting cable length	30 m (98.5 ft) – available as option	
Bolts (4)	M8x30 - 304 stainless steel	
Footprint	W233 mm (9.17") (port / starboard) x L141.5 mm (5.55") (matches Garmin GMR18HD / Raymarine RD218 footprint)	
Compatible Displays		
Simrad:	Lowrance:	B&G:
NSO, NSE, NSS	HDS 5", 7", 8", 10"	Zeus 8" & 12"

Navico Broadband radar part numbers

Broadband radar scanner part numbers			
Model	Part Number	Description	Length
Scanner			
3G™	AA010186	Broadband radar scanner	
Interface boxes			
RI10	AA010189	Broadband radar SimNet interface box	
Scanner cables			
	AA010211	Broadband scanner interconnection cable	10 m (33 ft)
	AA010212	Broadband scanner interconnection cable	20 m (65.6 ft)
	AA010213	Broadband scanner interconnection cable	30 m (98.5 ft)
Ethernet cables			
	000-00127-56	Adapter cable: yellow Ethernet male to RJ45 female (Supplied with Lowrance USA SKU)	2 m (6.5 ft)
	000-00127-28	Ethernet cable	0.6 m (2 ft)
	000-0127-51	Ethernet cable (Supplied with 3G™ radar)	1.8 m (6 ft)
	000-0127-29	Ethernet cable	4.5 m (15 ft)
	000-0127-30	Ethernet cable	7.7 m (25 ft)
	000-0127-37	Ethernet cable	15.2 m (50 ft)
SimNet cables			
	24005829	SimNet cable	0.3 m (1 ft)
	24005837	SimNet cable	2 m (6.6 ft)
	24005845	SimNet cable	5 m (16 ft)
	24005852	SimNet cable note: For simNet backbone only	10 m (33 ft)
SimNet - NMEA2000 adapter cables			
	24006413	Micro-C female to SimNet	4 m (13 ft)
	24006199	SimNet to Micro-C (female) cable that connects a NMEA 2000® product to SimNet	0.5 m (1.6 ft)
	24005729	SimNet to Micro-C (male) cable that connects a SimNet product to a NMEA 2000® network	0.5 m (1.6 ft)
NMEA - SimNet Converters			
AT10	24005936	AT10 NMEA0183 / SimNet converter	
AT10HD	24006694	AT10HD NMEA0183 / SimNet converter. 10 Hz heading data only	



849 NW State Road 45
 Newberry FL 32669
 352-472-5500 F: 352-472-2030
info@timcoengr.com
www.timco.cc

REPORT

Compliance to RF exposure requirements of OET 65

APPLICANT	NAVICO AUCKLAND LTD
ADDRESS	3-5 OMEGA STREET, BUILDING A ALBANY 0632 AUCKLAND NEW ZEALAND
TEL	011-64-9-925-4500
FCC ID	RAY3G4G
MODEL NUMBER	3G
PRODUCT DESCRIPTION	FMCW RADAR SCANNER
DATE SAMPLE RECEIVED	January/14/2011
DATE TESTED	January/15/202011
TESTED BY	Nam Nguyen
APPROVED BY	Mario de Aranzeta
TIMCO REPORT NO.	RF EXPOSURE REPORT
TEST RESULTS	<input checked="" type="checkbox"/> PASS <input type="checkbox"/> FAIL

THE ATTACHED REPORT SHALL NOT BE REPRODUCED EXCEPT IN FULL WITHOUT THE WRITTEN APPROVAL OF TIMCO ENGINEERING, INC.

THE RESULTS HEREIN RELATE ONLY TO THE ITEMS TESTED



Testing Certificate 0955-01

APPLICANT: NAVICO AUCKLAND LTD
 FCC ID: RAY3G4G
 REPORT #: Y:\N\NAVICO AUCKLAND_RAY\Radar\RF EXPOSURE REPORT.doc



General Remarks

Summary

The device under test does:

- fulfill the requirements as identified in this test report
- not fulfill the requirements as identified in this test report

This equipment has been tested in accordance with the standards identified in the referenced test report. To the best of my knowledge and belief, these tests were performed using the measurement procedures described in this report.

I attest that the necessary measurements were made by me or under my supervision, at TIMCO ENGINEERING, INC. located at 849 N.W. State Road 45, Newberry, Florida 32669 USA.

All Timco instrumentation and accessories used to test products for compliance to the indicated standards are calibrated regularly in accordance with ISO 17025: 2005 requirements.

Timco Engineering Inc.
849 NW State Road 45
Newberry, Fl 32669

Authorized Signatory Name and Title: Mario de Aranzeta, Compliance Engineer



Authorized Signature:



Testing Certificate #0955-1

APPLICANT: NAVICO AUCKLAND LTD
FCC ID: RAY3G4G
REPORT #: Y:\NAVICO AUCKLAND_RAY\Radar\RF EXPOSURE REPORT.doc



LOWRANCE®

SIMRAD

B&G