

**SIMRAD**

# RS35 VHF HS35 Handset

## Installation Instructions

ENGLISH



Simrad® is a registered trademark of Navico

No part of this manual may be copied, reproduced, republished, transmitted or distributed for any purpose, without prior written consent of Simrad Electronics.





**Any unauthorized commercial distribution of this manual is strictly prohibited.**

Simrad Electronics may find it necessary to change or end our policies, regulations, and special offers at any time. We reserve the right to do so without notice. All features and specifications subject to change without notice.

All screens in this manual are simulated.

For free owner's manuals and the most current information on this product, its operation and accessories, visit our web site: [www.simrad-yachting.com](http://www.simrad-yachting.com)

Navico Holding A S is not responsible for any changes or modifications to the radio not expressly approved by us as the responsible entity for its compliance. Modifications could void the user's authority to operate the radio.

<b>IMPORTANT SAFETY INFORMATION</b> Please read carefully before installation and use.	
	This is the safety alert symbol. It is used to alert you to potential personal injury hazards, Obey all safety messages that follow this symbol to avoid possible injury or death.
	WARNING indicates a potentially hazardous situation which, if not avoided, could result in death or serious injury
	CAUTION indicates a potentially hazardous situation which, if not avoided, could result in minor or moderate injury.
	CAUTION used without the safety alert symbol indicates a potentially hazardous situation which, if not avoided, may result in property damage.

# Table of contents

<b>1 Installation preparation .....</b>	<b>6</b>
1.1 Checklist.....	6
1.2 Tools needed for installation .....	6
<b>2 VHF installation.....</b>	<b>7</b>
2.1 Location requirements .....	7
2.2 LCD viewing angle .....	7
2.3 Choose an installation type .....	7
2.3.1 Mounting bracket installation.....	8
2.3.2 Recessed installation .....	9
2.4 RS35 dimensions .....	10
2.5 Handset mic wall hanger.....	11
<b>3 VHF electrical installation.....</b>	<b>12</b>
3.1 Connect the radio.....	12
3.2 Wiring diagram - NMEA 2000 connections .....	15
3.3 Wiring diagram - External speaker and hailer .....	16
3.4 Wiring diagram - NMEA 0183 connections .....	17
<b>4 HS35 Handset installation .....</b>	<b>18</b>
<b>5 Setup your radio - Your user MMSI.....</b>	<b>20</b>

## Important safety information

**DISCLAIMER:** It is the owner's sole responsibility to install and use the instrument and transducers in a manner that will not cause accidents, personal injury or property damage. The user of this product is solely responsible for observing safe boating practices.

NAVICO HOLDING AS. AND ITS SUBSIDIARIES, BRANCHES AND AFFILIATES DISCLAIM ALL LIABILITY FOR ANY USE OF THIS PRODUCT IN A WAY THAT MAY CAUSE ACCIDENTS, DAMAGE OR THAT MAY VIOLATE THE LAW.

Governing Language: This statement, any instruction manuals, user guides and

other information relating to the product (Documentation) may be translated to, or has been translated from, another language (Translation). In the event of any conflict between any Translation of the Documentation, the English language version of the Documentation will be the official version of the Documentation.

This manual represents the RS35 and HS35 as at the time of printing. Navico Holding AS. and its subsidiaries, branches and affiliates reserve the right to make changes to specifications without notice.

### IMPORTANT:

1. DSC functions will not operate on the RS35 until your MMSI has been entered. Refer to DSC Setup section for details.
2. The radio channels installed into this Simrad VHF radio may vary from country to country depending upon the model and government or national communications authority regulations.
3. Navico recommends that you check the radio operating licensing requirements of your country before using this Simrad VHF radio. The operator is solely responsible for observing proper radio installation and usage practices.
4. A DSC warning label is supplied with this Simrad VHF radio. To comply with FCC regulations, this label must be affixed in a location that is clearly visible from the operating controls of this radio. Make sure that the chosen location is clean and dry before applying this label.
5. This radio is designed to generate a digital maritime distress call to facilitate search and rescue. To be effective as a safety device, this radio must be used only within the geographic range of a shore-based VHF marine Channel 70 distress and safety watch system. The geographic range may vary but under normal conditions is approximately 20 nautical miles.

### MMSI and license information:

You must obtain a user MMSI (Marine Mobile Service Identity) and enter it into your RS35 in order to use the DSC functions. Contact the appropriate authorities in your country. If you are unsure who to contact, consult your Simrad dealer.

The user MMSI is a unique nine digit number, similar to a personal telephone number. It is used on marine transceivers that are capable of using DSC (Digital Select Calling).

Depending upon your location, you may need a radio station license for the RS35. You may also need an individual operator's license.

**Simrad recommends that you check the requirements of your national radio communications authorities before operating DSC functions.**

#### **RF Emissions notice:**

This equipment complies with FCC radiation exposure limits set forth for an uncontrolled environment. This device's antenna must be installed in accordance with provided instructions; and it must be operated with minimum 96 cm spacing between the antennas and all person's body (excluding extremities of hands, wrist and feet) during operation. Further, this transmitter must not be co-located or operated in conjunction with any other antenna or transmitter.

#### **FCC Statement**

This device complies with Part 15 of the FCC Rules. Operation is subject to the following two conditions: (1) this device may not cause harmful interference, and (2) this device must accept any interference received, including interference that may cause undesired operation.

**Note:** This equipment has been tested and found to comply with the limits for a Class B digital device, pursuant to Part 15 of the FCC Rules. These limits are designed to provide reasonable protection against harmful interference in a normal installation. This equipment generates, uses and can radiate radio frequency energy and, if not installed and used in accordance with the instructions, may cause harmful interference to radio communications. However, there is no guarantee that interference will not occur in a particular installation. If this equipment does cause harmful interference to radio or television reception, which can be determined by turning the equipment off and on, the user is encouraged to try to correct the interference by one or more of the following measures:

- Reorient or relocate the receiving antenna.
- Increase the separation between the equipment and receiver.
- Connect the equipment into an output on a circuit different from that to which the receiver is connected.
- Consult the dealer or an experienced technician for help.
- A shielded cable must be used when connecting a peripheral to the serial ports.

#### **Industry Canada Statement**

This device complies with Industry Canada license-exempt RSS standard(s).

Operation is Subject to the following two conditions: (1) this device may not cause interference, and (2) this device must accept any interference, including interference that may cause undesired operation of the device.

Le présent appareil est conforme aux CNR d'industrie Canada applicables aux appareils radio exempts de licence.

L'exploitation est autorisée aux deux conditions suivantes : (1) l'appareil ne doit pas produire de brouillage, et (2) l'utilisateur de l'appareil doit accepter tout brouillage radioélectrique subi, même si le brouillage est susceptible d'en compromettre le fonctionnement.

#### **Notice specific to the HS35**

This ISM device complies with Canadian ICES-001.

Maintain a minimum separation of 2.5 cm (1 inch) from the face.

Cet appareil ISM est conforme à la norme NMB-001 du Canada.

Maintenir une distance minimale de 2,5 cm (1 po) de l'écran.

#### **CE Compliance Statement**

This product complies with CE under R&TTE directive 1999/5/EC. The relevant Declaration of Conformity is available in the following website under model documentation section:  
<http://www.simrad-yachting.com>

# 1 Installation preparation

## 1.1 Checklist

---

Check that you have all the following items **before** starting the installation. Contact your dealer if an item is missing:

- RS35 base station, with microphone attached
- Dust cover
- GPS connector cable
- Speaker connector cable
- Power supply cable (with 7 A fuseholder incorporated)
- Spare 7 A fuse
- Mounting bracket, with:
  - 4 self-tapping screws
  - 4 flat screws
  - 4 plain washers
  - 4 spring washers
  - 4 nuts
  - 2 mounting knobs
- Handset mic wall hanger, with:
  - 2 self-tapping screws
  - 2 flat screws
  - 2 plain washers
  - 2 spring washers
  - 2 nuts
- 2 M5 x 32 screws with 2 plain washers and 2 nuts (for a recessed installation)
- Operation Manual
- Installation Manual
- Warranty Card
- DSC Warning Label
- Template for flush mounting option
- Declaration of Conformity document (where applicable)

**Note:** A VHF antenna is **not** provided by Simrad. Consult your Simrad dealer for advice if necessary.

## 1.2 Tools needed for installation

---

You will need the following tools:

- Power drill (or hand drill) and drill bits
- Philips screwdriver
- Spanner
- Jig saw (for a recessed installation).

## 2 VHF installation

### 2.1 Location requirements

Please check these **before** doing any cutting or drilling.

Whichever installation method you choose, ensure that the chosen location:

- Is at least 3' (1 m) from the antenna
- Allows easy connection to (at least) a 10 Amp fused 13.6 V DC electrical source and the antenna
- Is at least 1.5' (45 cm) from the compass to avoid creating magnetic deviation of the compass during radio operation
- Has a suitable space close by for installing the microphone bulkhead mount
- Provides easy access to the controls on the front panel
- Provides reasonable access to the wiring at the back of the radio
- Provides enough room to fix the DSC warning label.

### 2.2 LCD viewing angle

The VHF has a large LCD screen with an optimum viewing angle of approx.  $\pm 20$  deg. Ensure the chosen location provides a suitable view of the display. Ideally, the user should be directly in front of the display or no more than  $\pm 20$  deg from the front of the display.

**Note:** If unsure, temporarily power up the radio and check for a suitable location.

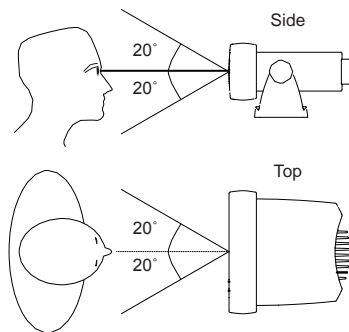

### 2.3 Choose an installation type

There are two ways to install the radio. You can choose:

- *Deck or overhead mounting bracket installation.* The reversible mounting gimbal is fixed to a suitable site and the radio is placed into it. The radio can be removed for storage and the viewing angle can be adjusted.
- *In dash or recessed installation.* The radio is recessed into a cavity cut into a bulkhead. The radio fixture is permanent and the viewing angle cannot be adjusted.

## 2.3.1 Mounting bracket installation

1. Hold the supplied mounting bracket at the chosen location and use a soft pencil to mark the 4 screw hole positions onto the mounting surface.
2. Drill the 4 screw holes where marked. Drill completely through the mounting surface.  
**Note:** If you are drilling into fiberglass, use a small drill bit to drill pilot holes before drilling the screw holes.
3. Use the flat screws, spring washers, plain washers, and nuts to attach the mounting bracket to the location site OR, if you cannot reach behind the mounting surface to attach the nuts, use the self-tapping screws instead of the flat screws.
4. Slide the radio into the mounting bracket.
5. Insert the 2 mounting knobs through the holes and tighten them sufficiently to hold the radio at your preferred viewing angle.
6. You can adjust the viewing angle at any time. The viewing angle has a 20° tilt range.
7. Now install the microphone wall hanger.

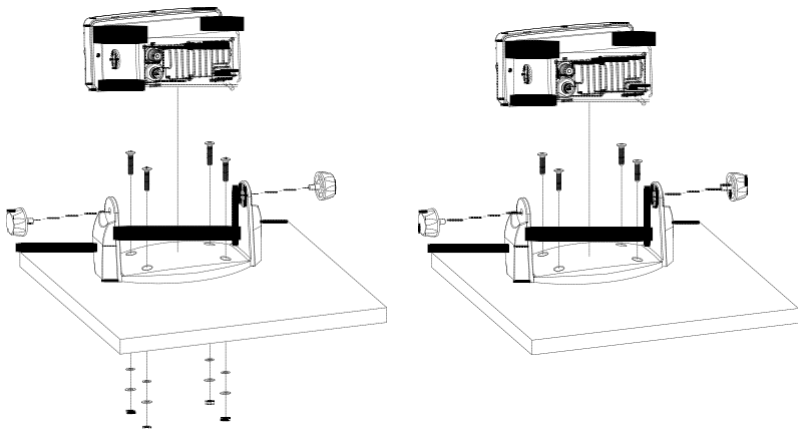



### 2.3.2 Recessed installation

---

1. Tape the supplied mounting template to the chosen location. Ensure that the template is smooth and taut.
2. Drill the 2 screw holes where marked. Drill completely through the mounting surface.  
**Note:** If you are drilling into fiberglass, use a small drill bit to drill pilot holes before drilling the screw holes.
3. Drill through the corners of the hatched area where marked, then cut out the hatched area to create a cavity in the mounting surface. (The dashed line shows the total area that will be covered by the radio fascia after installation).
4. Remove the mounting template and slide the radio into the cavity.
5. Working from the rear of the bulkhead, screw the radio firmly to the mounting surface using the 2 M5 x 32 screws with the plain washers and nuts.  
(The screws should not be visible from the front of the radio).
6. Now install the microphone wall hanger.

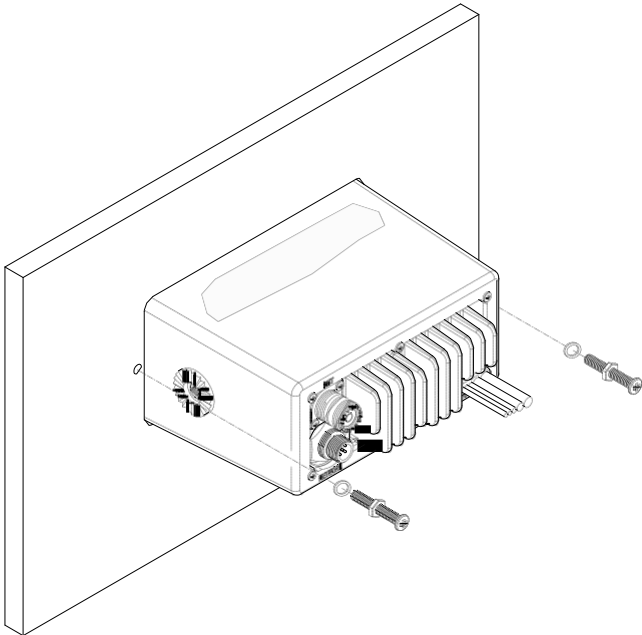

## 2.4 RS35 dimensions

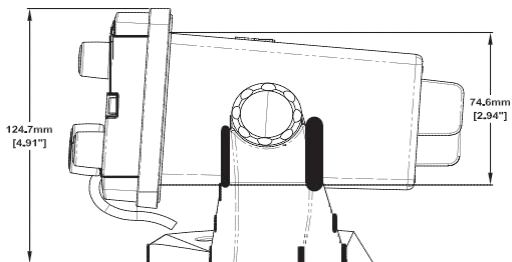
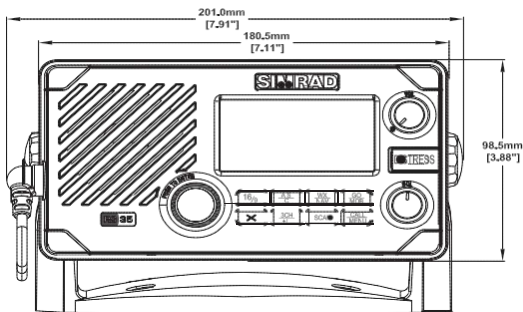
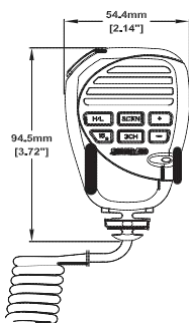
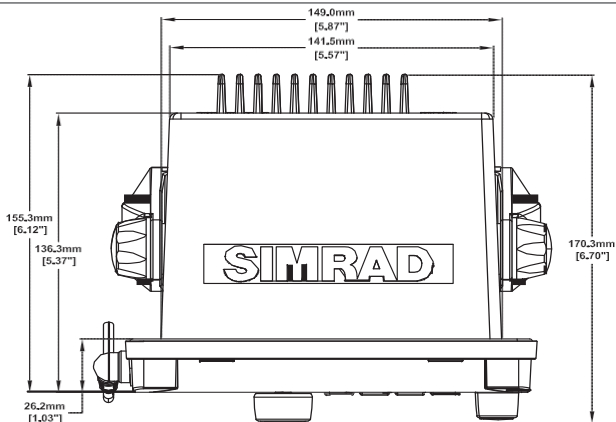

## 2.5 Handset mic wall hanger

---

1. Hold the handset mic wall hanger at the chosen location and use a soft pencil to mark the 2 screw hole positions onto the mounting surface.
2. If the mounting surface is:
  - non-metallic, use the 2 self-tapping screws and 2 plain washers to attach the handset mic wall hanger to the mounting surface.
  - metallic, use the 2 flat screws, 2 spring washers and 2 nuts to attach the handset mic wall hanger to the mounting surface.
3. Hang the handset mic on the handset mic wall hanger.
4. Now connect the radio.

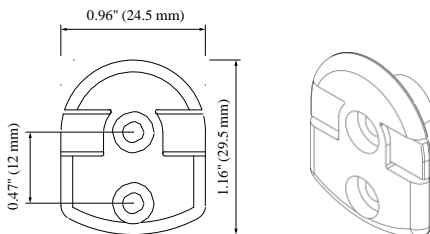

## 3 VHF electrical installation

### 3.1 Connect the radio

Both NMEA 0183 and NMEA 2000 is supported by this radio. Use the GPS connector cable to connect NMEA 0183, or the N2K connector for NMEA 2000 connections.

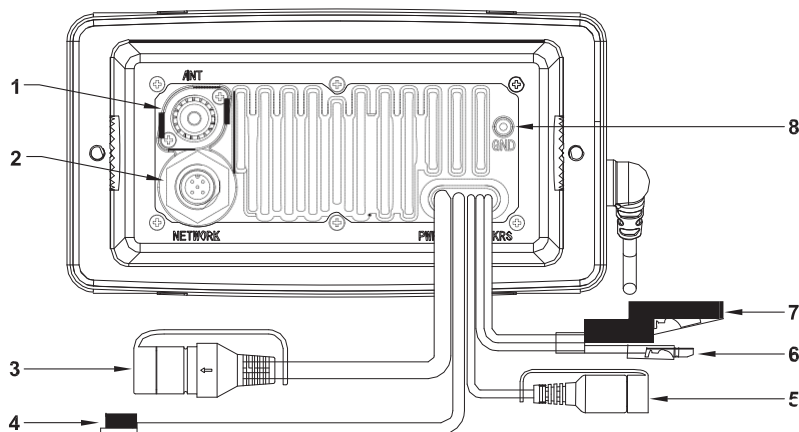

#### 1 - VHF antenna

A suitable radio antenna (not supplied) must be mounted and connected before you can operate the radio. Consult your Simrad dealer for advice, if necessary.

**Always** mount the VHF antenna as high as possible and at least 37" (96 cm) from the base station.

#### 2 - NMEA 2000 (N2K) connector

The radio can be connected to an NMEA 2000 network via the NMEA 2000 NETWORK connector on the rear of the radio by a compliant N2K cable (not supplied).



Pin / Socket	Wire color	Function (NMEA 2000)
1	Green	Can-D, Drain wire, Shield
2	Red	Can-S, Power, +12 V DC
3	Black	Can-C, Ground
4	White	Can-H, Data High
5	Blue	Can-L, Data Low

### 3 - GPS Connector and cable

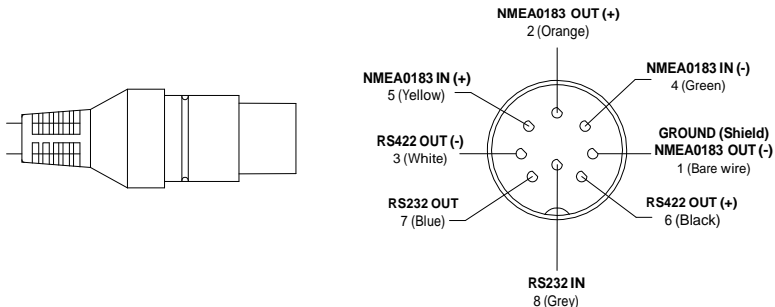

Line up the arrow on the GPS connector with the arrow on the GPS cable and plug together. The pin details are shown for information.

Pin / Socket	Wire color	GPS / MFD (NMEA 0183)		AIS (NMEA 0183 HS)	
1	Shield	GROUND, NMEA 0183 OUT (-)	4800bps	RS232 OUT (-)	38.4 kbps
2	Orange	NMEA 0183 OUT (+)	4800bps		
3	White			RS422 OUT (-)	38.4 kbps
4	Green	NMEA 0183 IN (-)	4800bps		
5	Yellow	NMEA 0183 IN (+)	4800bps		
6	Black			RS422 OUT (+)	38.4 kbps
7	Blue			RS232 OUT (+)	38.4 kbps
8	Grey	RS232 IN	Not used		

*Note:* The GPS connector on the radio is provided with a protective cover. If this connector will not be used, please ensure the protective cover is fitted.

#### 4 - Hailer Horn

Wire color	Function	Details
White	(+)	Connect to hailer speaker +
Shield	(-) Shield	Connect to hailer speaker -

**Important:** Do not short circuit these 2 wires. Install the hailer horn in a forward-facing location on the boat because the hailer horn will transmit the FOG horn sounds and will 'listen back' when not transmitting.

**Note:** We recommend you use a hailer horn of 4 Ohms to obtain maximum 30 W audio output power.

#### 5 - External speaker

You can connect 1 x 2 W 8Ω or 1 x 4 W 4Ω speaker to the 3.5 mm speaker connector. A speaker cable with 3.5 mm plug is provided to make the connection to the speaker.

Wire color	Function	Details
White	Speaker (+)	Connect this wire to the positive terminal of the speaker.
Black	Speaker (-)	Connect this wire to the negative terminal of the speaker.

#### 6, 7 - DC Power

Wire color	Function	Details
6 - Red	(+) 13.6 V DC	Connect this wire to the positive battery terminal. Use at least a 10 A fused 13.6 V DC electrical service to the radio.
7 - Black	(-) Ground	Connect this wire to the battery negative terminal.

#### 8 - Ground

The vessel's battery negative **must** be common to the boat's **Ground** (Optional). You can connect the base station to the boat's Ground. Use the Ground screw and Ground plain washer supplied to make this connection.



## 3.2 Wiring diagram - NMEA 2000 connections

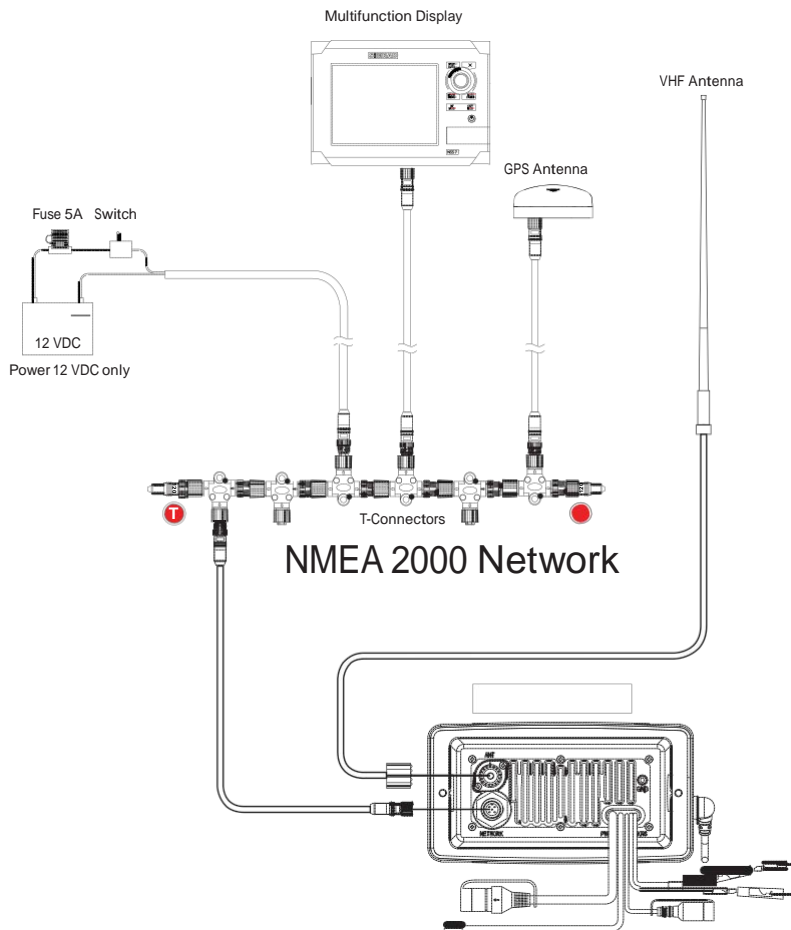



### 3.3 Wiring diagram - External speaker and hailer

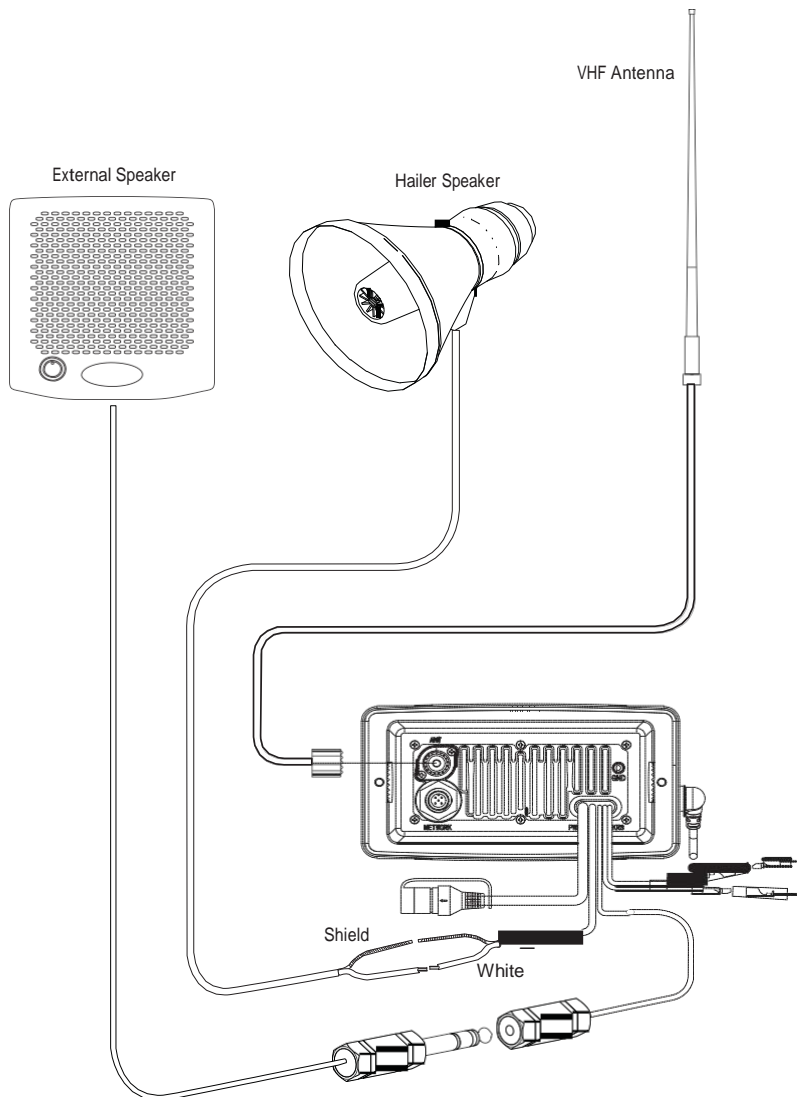



### 3.17 Wiring diagram - NMEA 0183

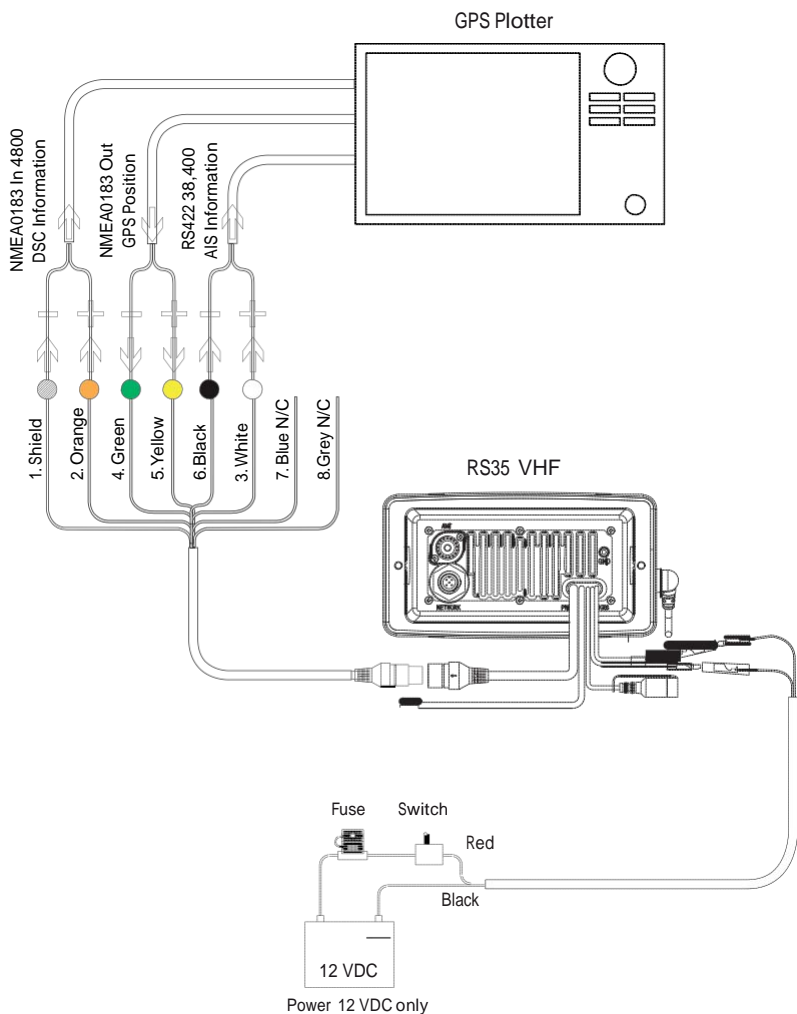

## 4 HS35 Handset installation

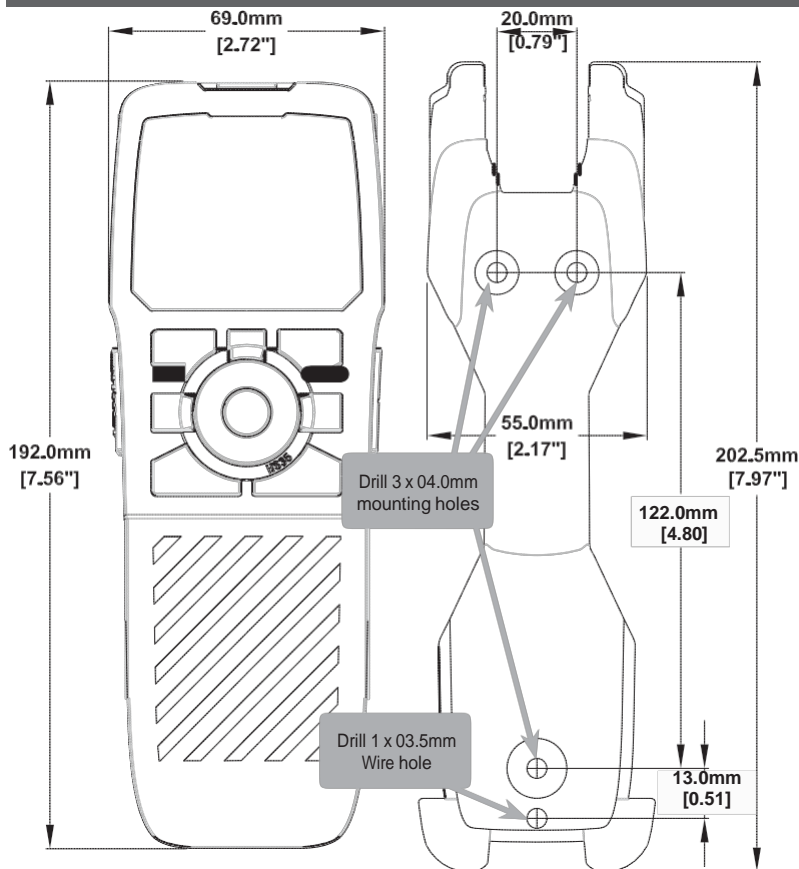

1. Choose a suitable location that ensures sufficient room is allocated to allow the HS35 handset to fit securely in the charging bracket.
2. Hold the supplied mounting bracket at the chosen location and use a soft pencil to mark the 3 screw holes and 1 wire hole positions onto the mounting surface.
3. Drill the 3 screw holes (0 4.0 mm) and 1 wire hole (0 3.5mm) where marked. Drill completely through the mounting surface.

**Note:** If you are drilling into fiberglass, use a small drill bit to drill pilot holes before drilling the screw holes.

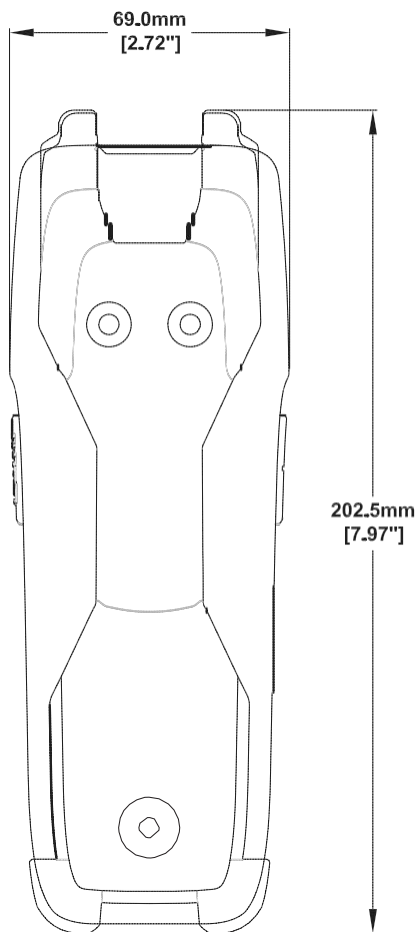

4. Feed the DC connection wire through the wire hole (lower hole).
5. Use the flat screws, spring washers, plain washers, and nuts to attach the mounting bracket to the location site OR, if you cannot reach behind the mounting surface to attach the nuts, use the self-tapping screws instead of the flat screws.
6. Connect the DC connection wire to a 12 V DC source via a 1A fuse. Red wire to battery (+); black wire to battery (-).

## 5 Setup your radio - Your user MMSI

### **! CAUTION**

You can't make any DSC transmissions until you've obtained a user MMSI and entered it into your radio.

You must enter your User MMSI before the DSC functions of this radio will work.

See the Setup section in the RS35 User Guide for full setup details.



### **! CAUTION**

*Under extreme operating conditions, the temperature of the rear heat-sink on this radio may exceed normal surface temperatures. Caution is advised to prevent possible skin burns.*





**SIMRAD**

CE 1177CD