



Explorer 721US / 721EU

Explorer 725US / 725EU





VHF Marine Radio

Operation and Installation Manual

NORTHSTAR 

www.northstarnav.com

IMPORTANT SAFETY INFORMATION
Please read carefully before installation and use.

	This is the safety alert symbol. It is used to alert you to potential personal injury hazards, Obey all safety messages that follow this symbol to avoid possible injury or death.
	WARNING indicates a potentially hazardous situation which, if not avoided, could result in death or serious injury
	CAUTION indicates a potentially hazardous situation which, if not avoided, could result in minor or moderate injury.
	CAUTION used without the safety alert symbol indicates a potentially hazardous situation which, if not avoided, may result in property damage.

DISCLAIMER: It is the owner's sole responsibility to install and use the instrument and transducers in a manner that will not cause accidents, personal injury or property damage. The user of this product is solely responsible for observing safe boating practices.

NAVICO HOLDING AS. AND ITS SUBSIDIARIES, BRANCHES AND AFFILIATES DISCLAIM ALL LIABILITY FOR ANY USE OF THIS PRODUCT IN A WAY THAT MAY CAUSE ACCIDENTS, DAMAGE OR THAT MAY VIOLATE THE LAW.

Governing Language: This statement, any instruction manuals, user guides and other information relating to the product (Documentation) may be translated to, or

has been translated from, another language (Translation). In the event of any conflict between any Translation of the Documentation, the English language version of the Documentation will be the official version of the Documentation.

This manual represents the Explorer 721 and Explorer 725 as at the time of printing. Navico Holding AS. and its subsidiaries, branches and affiliates reserve the right to make changes to specifications without notice.

Copyright © 2008 Navico Holding AS.
Northstar™ is a registered trademark of Navico Holding AS.

FCC Statement

This equipment has been tested and found to comply with the limits for a Class B digital device, pursuant to Part 15 of the FCC Rules. These limits are designed to provide reasonable protection against harmful interference in a normal installation. This equipment generates, uses and can radiate radio frequency energy and, if not installed and used in accordance with the instructions, may cause harmful interference to radio communications. However, there is no guarantee that interference will not occur in a particular installation. If this equipment does cause harmful interference to radio or television reception, which can be determined by turning the equipment off and on, the user is encouraged to try to correct the interference by one or more of the following measures:

- Reorient or relocate the receiving antenna.
- Increase the separation between the equipment and receiver.
- Connect the equipment into an outlet on a circuit different from that to which the receiver is connected.
- Consult the dealer or an experienced technician for help.
- A shielded cable must be used when connecting a peripheral to the serial ports.

CAUTION: Changes or modifications not expressly approved by the manufacturer could void the user's authority to operate the equipment.

This device complies with part 15 of the FCC Rules. Operation is subject to the following two conditions: (1) This device may not cause harmful interference, and (2) this device must accept any interference received, including interference that may cause undesired operation.

Contents

Section 1 - General Information	6
1-1 Features	6
1-2 Customize your Northstar VHF Radio	7
1-3 How to Display and Navigate Menus.....	7
1-4 How to Enter or Change Alphanumeric Data.....	7
1-5 LCD Symbols and Meanings	8
1-6 How the Microphone and 701 Optional Handset Work Together.....	10
1-7 Basic Operation and Key Functions	10
Section 2 - The Radio Menu (MENU)	13
2-1 The Radio Menu Options (MENU)	13
2-2 Show Weather, SNR or Happy Fish on Handset (INFO DATA)	14
2-3 Maintain Your Buddy List (BUDDY LIST)	15
2-4 Local or Distance Sensitivity (LOCAL/DIST)	16
2-5 Backlighting (BACKLIGHT) and Contrast (CONTRAST)	16
2-6 GPS Data and Time (GPS/DATA).....	17
2-7 GPS Simulator (GPS SIM)	20
2-8 Reset to Factory Defaults (RESET)	20
2-9 Subscribe or Un-Subscribe the 705 handset (HS SETTING).....	21
Section 3 - Radio Setup Menu (RADIO SETUP)	22
3-1 The Radio Setup Menu Options (RADIO SETUP)	22
3-2 Select the Channel Bank (UIC) <i>(US only)</i>	22
3-3 Change Channel Names (CH NAME).....	23
3-4 Ring and Beep Volume (RING VOLUME and KEY BEEP)	23
3-5 Internal Speaker Connections (INT SPEAKER)	23
3-6 Set the Priority Channel (WATCH MODE).....	24
3-7 Weather Alert (WX ALERT) <i>(US only)</i>	24
3-8 NMEA or NAVBUS protocol (COM PORT) <i>(721 / 725 only)</i>	24
3-9 Barometric Displays (BARO SENSOR)	25
3-10 Temperature Display (TEMPERATURE)	27
3-11 HAPPY FISH Alarm ON or OFF	27
Section 4 - DSC SETUP Menu	28
4-1 What is DSC?	28
4-2 DSC SETUP Menu Options	28
4-3 Check Your User MMSI (USER MMSI)	28
4-4 Maintain Your Groups (GROUP SETUP).....	28

4-5 Response to Individual Calls (INDIV REPLY) <i>(US only)</i>	30
4-6 ATIS MMSI & ATIS Functionality <i>(EU only)</i>	30
4-7 DSC Functionality (DSC FUNC)	31
4-8 Response Type to LL Polling Calls (LL REPLY)	31
4-9 Mute the Notification Ringtone	31
Section 5 - Send and Receive DSC Calls	32
5-1 The DSC CALL Menu Options	32
5-2 Call an Individual (INDIVIDUAL)	33
5-3 Call the Most Recent Caller (LAST CALL)	34
5-4 Call a Group (GROUP)	34
5-5 Call All Ships (ALL SHIPS)	34
5-6 Call using the Call Log (CALL LOG)	35
5-7 Call using the Distress Log (DIST LOG)	35
5-8 Request the LL Position of a Buddy (LL REQUEST)	36
5-9 Track Your Buddy (TRACK BUDDY)	36
5-10 Receive an All Ships Call (RCV: ALL SHIP)	38
5-11 Receive an Individual Call (RCV: INDIV)	38
5-12 Receive a Group Call (RCV: GROUP)	39
5-13 Receive a Geographic Call (RCV: GEOGRAPH)	39
5-14 Receive a Polled Position Call (RCV: POSITION)	39
Section 6 - Distress Calls	40
6-1 Send a Distress Call	40
6-2 Receive a Distress Acknowledgement (DISTRESS ACK)	40
6-3 Receive a Distress Call (RCV: DISTRESS)	41
6-4 Receive a Distress Relay (RCV: DISTRESS RELAY)	41
6-5 Relay a Distress Call from the Distress Log (RELAY)	41
Appendix A - Technical Specifications	42
Northstar Explorer 721/725US and 721/725EU	42
Appendix B - Troubleshooting	44
Appendix C - VHF Marine Channel Charts	45
Appendix D - EU Inland Waterway Channels	52
Appendix E - MMSI and License Information	56
E-1 Obtain Your User MMSI number	56
E-2 Enter Your User MMSI	56
E-3 License Information	56

Section 7 - Install the Explorer 721/725	57
7-1 Installation Options	57
7-2 Location Requirements	57
7-3 Checklist	58
7-4 Gimbal Installation	59
7-5 Change the Viewing Angle	59
7-6 Recessed Installation	59
7-7 Install the Microphone Bulkhead Mount	60
7-8 Connect the Radio Cables	61
7-9 Set Up the Radio	62
7-11 The Completed Installation (with Optional 701 Handset)	63

ABOUT THIS MANUAL:

1. Some features described in this manual are not available on every model.
2. This manual is based on the **VHF721 US/EU** models - the **VHF725 US/EU** models are functional identical to the VHF721US/EU except for where noted throughout this manual.
3. DSC functions will not operate on this radio until a valid user MMSI has been entered and stored. See Appendix- D for details.
4. The radio channels installed into the radio may vary from country to country, depending upon the model and government or national communications authority regulations.
5. NAVICO recommends that you check the radio operating licensing requirements of your country before using the radio. The operator is solely responsible for observing proper radio installation and usage practices.
6. A DSC warning label is supplied with the 721/725 US model. To comply with FCC regulations, this label must be affixed in a location that is clearly visible from the operating controls of this radio. Make sure that the chosen location is clean and dry before applying this label.

Optional Handset

This manual describes the operation and installation procedures for the Northstar Explorer 721/725US and 721/725EU base unit and microphone. An optional Northstar 701/705US or 701/705EU handset can be purchased and installed to provide second station operation and intercom facilities.

Industry Canada

Operation is subject to the following two conditions: (1) this device may not cause interference, and (2) this device must accept any interference, including interference that may cause undesired operation of the device.

RF Emissions Notice:

This equipment complies with FCC radiation exposure limits set forth for an uncontrolled environment. This device's antenna must be installed in accordance with provided instructions; and it must be operated with minimum 96 cm spacing between the antennas and all person's body (excluding extremities of hands, wrist and feet) during operation. Further, this transmitter must not be co-located or operated in conjunction with any other antenna or transmitter.

Section 1 - General Information

1-1 Features

Congratulations on your purchase of a Northstar VHF Explorer 721/725US or 721/725EU marine band radio. Both of these models provide the following useful features:

- Adjustable contrast settings for the LCD
- Adjustable keypad backlighting for easy night-time use
- Waterproof and submersible to comply with JIS-7
- Choice of High or Low (25 W or 1 W) transmission power
- Access to all currently-available marine VHF channel banks (USA, Canada, International) including weather channels where available
- Special CH16 or CH16/9 key for quick access to the priority (International Distress) channel
- Special 3CH key for quick selection of your three favorite channels
- DISTRESS call button to automatically transmit the MMSI and position until an acknowledgement is received
- Easy access to a buddy list of up to 20 favorite people
- MMSI storage for three favorite groups
- GROUP CALL and ALL SHIPS CALL Facility
- Automatic position and time update when connected to a GPS receiver
- DSC (Digital Select Calling) capability that meets SC101 standards (721/725US only)
- DSC (Digital Select Calling) capability that meets EC Class D standards (721/725EU only)
- ATIS facility for inland waterways (721/725EU only)

In addition, the 721/725 US/EU models also provide:

- Prominent channel display and rotary channel selector knob with PRESS TO ENTER function
- GPS latitude and longitude (LL) and time display (when connected to a GPS)
- Powerful 4 W external audio output
- PSCAN (similar to dual watch) facility
- Info key to display barometric data and temperature, or Signal-to-Noise Ratio (SNR)
- Happy Fish symbol that indicates the fishing conditions
- LL position polling information and Track Your Buddy facility
- Local/Distance mode to eliminate noise in high traffic areas
- Weather alert facility. **721/725US only**
- Alphanumeric microphone for easy, direct channel entry and information editing. **721/725EU only**
- INTERCOM facility if the optional wired 701 handset is installed (for VHF721 model).
- INTERCOM facility if an optional wireless 705 handset is installed (for VHF725 model).
CONFERENCE facility if two 705 handsets installed (total 2 x 705 handsets can be installed).

1-2 Customize your Northstar VHF Radio

You can customize the radio to suit your individual preferences. Some preferences can be set directly through the keys as explained in this Section.

Other preferences are set up through the built-in menus and these are explained in the other Sections.

1-3 How to Display and Navigate Menus

1. **Hold down CALL/MENU** to show the **RADIO** menu
or
2. **Press CALL/MENU** to show the **DSC CALL** menu.
3. Only four menu items can be displayed at any one time on the LCD. Rotate the rotary knob to scroll up and down the menu until the cursor is positioned at the desired option. Press **ENT** (push the rotary knob in) to display that option.
4. Make any entries or changes as explained in the following section.3.
5. Press ENT to confirm changes. Otherwise, press EXIT to keep the original entry.4.
6. Press EXIT to backup one screen (this key is equivalent to an ESC function on a PC).5.

1-4 How to Enter or Change Alphanumeric Data

If your radio doesn't have an optional alphanumeric microphone, use the + CH - key on the microphone to enter alphanumeric data as follows:

- Press CH - to count through numbers, or hold down to scroll rapidly to the desired number.
- Press CH + to step through the alphabet, or hold down to scroll rapidly to the desired character.
- If you make an error, press CH - until < is displayed, then press ENT or push the rotary knob to backup and correct the entry.

If your radio has an alphanumeric microphone, use the keypad to enter the channel numbers and names. Each key has the functionality shown below.

- Use CLR to backup and ENT to confirm, or just wait for the cursor to advance automatically to the next position when entering data (similar to mobile phone operation),

On the base station, use the rotary knob to enter alphanumeric data and push to ENTER the data.

KEY	0	1	2	3	4	5	6	7	8	9
Normal and Menu Mode	0	1	2	3	4	5	6	7	8	9
Edit Mode Press 1	0	1	2	3	4	5	6	7	8	9
Press 2	Space	-	A	D	G	J	M	P	T	W
Press 3	(.	B	E	H	K	N	Q	U	X
Press 4)	"	C	F	I	L	O	R	V	Y
Press 5	%	/	?	!	:	#	"	S	&	Z

1-5 LCD Symbols and Meanings

The simulation shows the locations of all the following information symbols on the LCD displays.

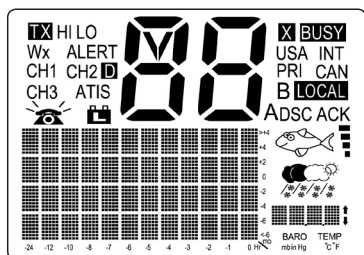

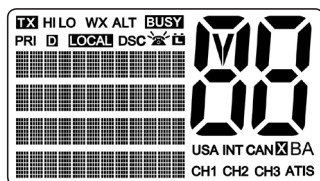

Base unit display



Optional handset display

These symbols may not appear at all or may be shown in a different location on the optional handset.

Symbol	Meaning
TX	Transmitting.
HI LO	Transmission power. High (HI) 25 W or Low (LO) 1 W.
WX	Weather channel.
WX ALT	Weather Alert. Alarm beeps will sound. 721/725 US only.
BUSY	Receiver busy with an incoming signal.
PRI	Priority channel is selected.
D	Duplex operation. Otherwise, blank for Simplex operation.
LOCAL	Local calling is selected. Otherwise, blank for distance calling.
DSC	DSC capability is available.
	Indicates an incoming DSC call, or blinks to notify you of any unread Call Log messages
	Low Battery warning (activates at 10.5 V)
BB	Channel selected.
USA INT CAN	Selected channel bank for VHF radio operations and regulations.
X	Channel is temporarily deleted from the ALL SCAN operation.
B A	Channel suffix, if applicable.
CH1 CH2 CH3	Shows which of the 3 favorite channels, if any, are selected. Otherwise blank.
ATIS	Enabled for use in European inland waterways. Otherwise blank. 721/725 EU only.
DSC	DSC capability is available.
ACK	A message acknowledging your DSC call is being displayed.

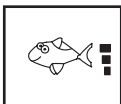

Happy Fish symbol with one to four indicator bars to show the probability of good fishing at your current location, based upon barometric pressure and air temperature. Four bars show that good fishing is likely. High pressure trends are associated with stable conditions and calm seas. Research indicates that best fishing occurs when barometric pressure is rising and between 1010 and 1022 mb. During these opportune conditions, most fish are thought to feed anywhere within the water column. However, low pressure trends bring stormy seas and affect air bladders, and these conditions make fish move to deeper levels and become less active. See section 2-2 for more information.



Local weather forecast based on the local temperature and stored barometric pressure data. The icons are indicative only and are more accurate close to land rather than in open sea.



Digital Readout of the current barometric pressure (in mb or in/Hg) or the current temperature (in °C or °F), depending upon your selection.

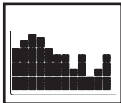

Baro Graph. A histogram of barometric pressure readings over the past 24 hours. The high-resolution histogram centres automatically if the range goes off scale. Readouts are taken even when the engine and radio have been powered down (with typically less than 3mA of current drain).

A typical operational display on the 721/725 base unit LCD:

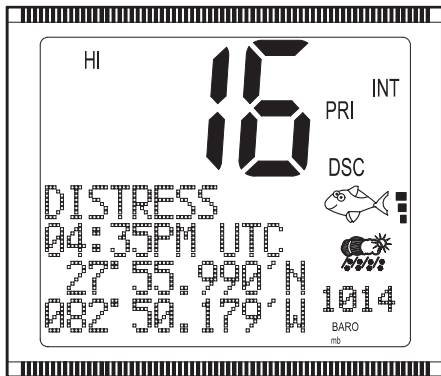

- A transmission on Channel 16 is being made at high power using the International channel bank.
- Channel 16 is set as the Priority channel.
- The latitude and longitude of the vessel and UTC time are shown.
- 3 bars by the Happy Fish indicates rising barometric trends and reasonable fishing conditions.
- The weather indicates showery conditions.

A typical operational display on the 701/705 Optional Handset LCD:

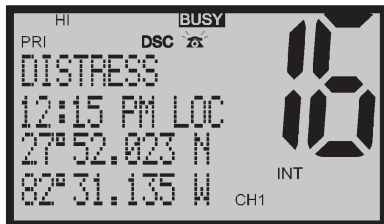

1-6 How the Microphone and 701 Optional Handset Work Together

Consult the 721/701 Quick Start Guide for additional operational instructions.

If you have the optional 701 handset installed on your VHF721:

- neither item will transmit while both are ON hook, but you can hear the audio from the handset speaker and adjust the handset volume.
- to use one item when it's OFF hook, the other item must be ON hook.
- if both items are OFF hook, only the microphone works.
- in Intercom mode ONLY, both items work OFF hook.

1-7 Basic Operation and Key Functions

All possible keys on the base unit, the microphone, and the optional handset are listed and their functions are explained.

NOTE: Some keys or functions may not be available on your particular model of base unit, microphone, or optional handset. This example shows the 721US base unit.

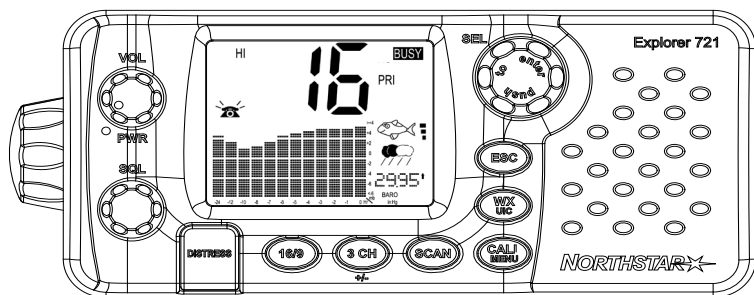

Key	Function
VOL PWR	Volume and Power. Turn clockwise to power on. Continue to turn until a comfortable volume is reached. VOL/PWR will also adjust the settings of an external speaker, if connected.
SQL	Squelch or Threshold Level. Sets the threshold level for the minimum receiver signal. Turn fully counterclockwise until random noise is heard, then turn slowly clockwise until the random noise disappears. Make another 1/4 turn clockwise for best reception in open sea conditions. In areas of high noise (e.g. close to large cities) reception may improve if sensitivity is reduced. Either turn SQL slowly clockwise or use the LOCAL setting. See section 2-4.
DISTRESS	Send DSC Distress Call. See Section 6.
16/9	Priority Channel. 721/725US only. Press to cancel all other modes and to tune into the priority channel. Press again to return to your original channel. The default is Channel 16. To make Channel 09 the priority channel, hold down 16/9 until a beep sounds and 09 is displayed.
16	Priority Channel. 721/725EU only. Press to cancel all other modes and to tune into the priority channel, Channel 16, on high power. Press again to return to your original channel.

- 3 CH** **Three Favorite Channels.** Press to toggle between your favorite channels. The CH1, CH2, or CH3 symbol appears on the LCD to show which favorite channel is selected.
- To scan only one of your favorite channels, press 3CH then immediately press and release SCAN. If you want to scan all three favorite channels, press 3CH then immediately press and hold SCAN.
- To add a favorite channel for the first time, select that channel then hold 3CH to store it in the CH1 location. Repeat the procedure to store two more favorite channels in the CH2 and CH3 locations respectively.
- If you try and add another favorite channel it will overwrite the existing CH3. CH1 and CH2 remain unless you delete them.
- To delete a favorite channel, select that channel then hold down 3CH until the CH1, CH2 or CH3 symbol disappears off the LCD.
- SCAN** **Scan.** Scanning is not allowed in some European countries. Otherwise, press to scan between your current channel and the priority channel in DUAL or TRI WATCH mode. The weather channel is also scanned if the USA channel bank is selected and the weather alert mode is ON.
- Hold down SCAN to enter ALL SCAN mode where the priority channel is checked every 1.5 seconds.
- When a signal is received, scanning stops at that channel and BUSY appears on the LCD. If the signal stops for more than 5 seconds, the scan restarts.
- Press ENT or push the rotary knob to temporarily skip over (lock out) an "always busy" channel when in ALL SCAN mode and resume the scan. An X is shown on the LCD to designate a skipped channel. It's not possible to skip over the priority channel.
- Press SCAN to stop at the current channel.
- CALL/MENU** **Radio Menu, DSC Set up Menu, Radio Set up Menu and DSC CALL Menu.**
- Hold down to show the radio menu (see Section 2) and to access the radio set up menu (see Section 3) and the DSC set up menu (see Section 4).
- Press to enter the DSC call menu and to make DSC calls (see Section 5).
- WX** **Weather Channel. 721/725US only.** In USA and Canadian waters, press to hear the most recently selected weather station. The WX symbol is displayed on the LCD.
- Press CH + or CH - to change to a different weather channel. Press WX again to return to the most recent channel.
- If the weather alert mode is ON and an alert tone of 1050 Hz is broadcast from the weather station, it's picked up automatically and the alarm sounds. Press any key to hear the weather alert voice message.
- IC or H/L IC** **Intercom. Optional 701 or 705 handset required.** Hold down to enter Intercom mode on USA models. EU models need just a single press and release. This disables the radio receiver except for incoming DSC calls and the intercom calls the other unit.
- Press PTT when invited. When you're finished, press ESC to exit Intercom mode or put the handset back on hook (**701 hadset only**.)
- ESC** **Escape.** Use ESC when navigating menus, to clear incorrect entries, to exit from a menu without saving changes, and to back up to the previous screen.

Rotary knob	<p>Channel Select. Turn to select a channel. The current channel is shown on the LCD in BIG digits with an A or B designator suffix (if applicable) in small letters below the channel number. (See Appendix C for a listing of channel frequencies.)</p> <p>Push to activate the ENT (Enter) function.</p> <p>You can also use the rotary knob for alphanumeric entry if you don't have an alphanumeric microphone. Turn to step through alphanumeric characters one at a time then push to confirm each selection. If you make an error, select the < character then push to backup.</p>
info	<p>Information. Press on the base MIKE to toggle through the INFO display to show the barometric histogram, the barometric readout and temperature, or the Signal-to-Noise Ratio (SNR).</p>
H/L	<p>Transmission Power. High (HI) 25 W or Low (LO) 1 W. Press to toggle between high or low transmission power for the entire channel bank. The HI or LO selection is shown on the LCD.</p> <p>Some channels allow only low power transmissions. Error beeps will sound if the power transmission setting is incorrect.</p> <p>Some channels allow only low power transmissions initially, but can be changed to high power by holding down H/L and PTT at the same time. See Appendix C for a complete listing of channel charts.</p>
+ CH -	<p>Channel Select. Press CH + or CH - to step through the available channels one at a time, or hold down to scroll rapidly through all the available channels. The current channel is shown on the LCD in BIG digits (with an A or B designator suffix if applicable in small letters below the channel number). (See Appendix C & D for a listing of channel frequencies.)</p> <p>Press CH + or CH - to scroll the cursor up and down menu options on the LCD when navigating menus.</p> <p>When editing an item containing only numbers, press CH - to step through the numbers or hold down to scroll rapidly.</p> <p>To enter a character, press Ch + to step through the alphabet or hold down to scroll rapidly.</p>
ENT	<p>Enter. Press ENT when navigating menus, to confirm entries and edits.</p>
PTT	<p>Press To Talk. Press PTT to transmit at any time on an allowable channel. This automatically exits you from menu mode and stops scanning.</p> <p>You must release PTT to receive a signal.</p> <p>If PTT sticks, a built-in timer will automatically shut down a transmission after five minutes and sound the error beeps. This timer is required by FCC regulations.</p>

Section 2 - The Radio Menu (MENU)

Hold down CALL/MENU to show the radio **MENU** options.

Sections 1-3 and 1-4 explain how to navigate around the menu and enter, save and change data.

2-1 The Radio Menu Options (MENU)

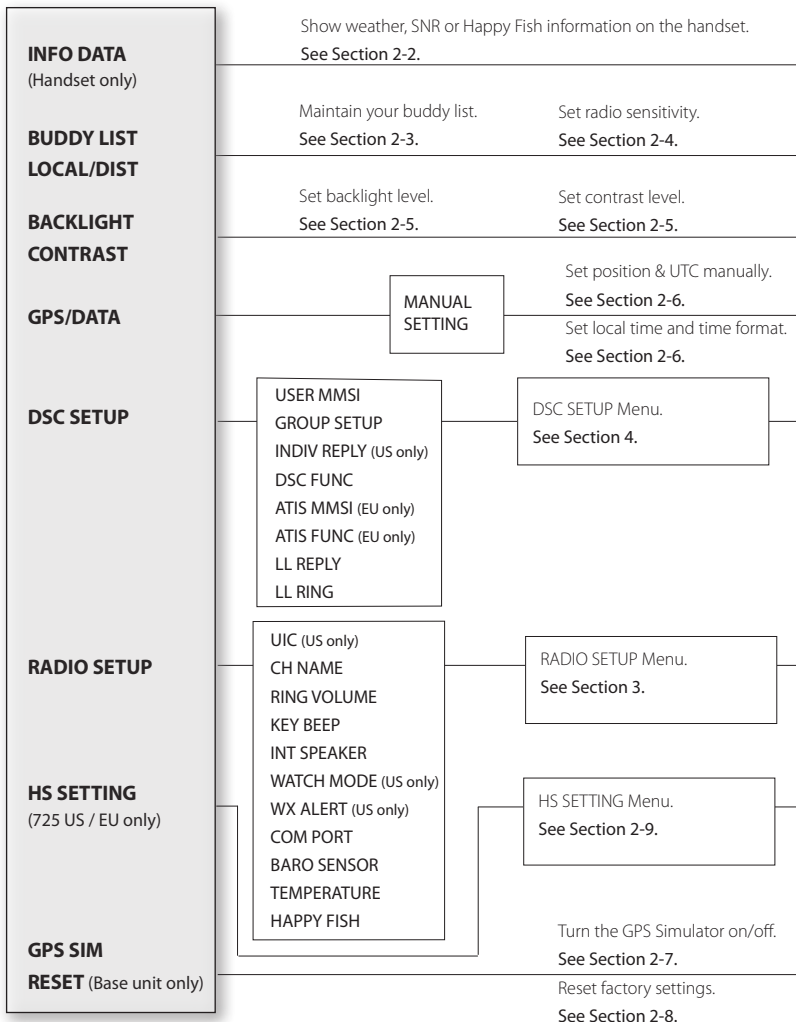

2-2 Show Weather, SNR or Happy Fish on Handset (INFO DATA)

If you have the optional handset installed, you can use INFO DATA to show the local weather forecast (e.g. SUNNY) and a digital readout of the current barometric pressure (mb or in-Hg) and the channel name on the handset LCD.

MENU SELECT >INFO DATA BUDDY LIST LOCAL/DIST	INFO DATA >ON OFF	DISTRESS A BIT CLOUDY 78.4°F 29.99in-Hg
---	-------------------------	--

After INFO DATA is selected ON, the following screen appears on the handset with Line #3 able to display 3 items of interest - temperature, Signal To Noise ratio (SNR) or HAPPY FISH quality.

- a digital readout of the current air temperature (°F or °C)
- the current Signal-to-Noise Ratio (SNR)
- the Happy Fish symbol with indicator bars.

1. Hold down CALL/MENU to display the radio menu.
2. The cursor is at INFO DATA. Press ENT then select INFO ON to display the information on the handset LCD, instead of the time and GPS position.
3. 78.4 deg F is displayed alternating with SNR bars.
4. Happy Fish symbol replaces TEMP/SNR if triggered after which it times out.

Information regarding Barometer, Weather and Happy Fish operation:

For these functions to operate correctly, the barometer sensor built into the microphone requires a permanent power connection. When the radio is turned off with the power knob on the radio, power continues to flow to the barometer sensor. This enables a 24 hour barometer trend to be collected and is used with the **Happy Fish** and **Weather** predictor.

Note: If the power supply to the radio is disconnected, the barometer trend will cease and will re-start when power is re-applied.

Happy Fish and Weather may not function, or may be inaccurate for several hours after initial power up.

2-3 Maintain Your Buddy List (BUDDY LIST)

```
MENU SELECT
>BUDDY LIST
  LOCAL/DIST
  BACKLIGHT
```

Use the Buddy List to store the names and associated MMSI's of 20 favorite people. Names are stored in the order of entry, with the most recent entry shown first.

The following sections show to use BUDDY LIST to add, edit, and delete entries in your buddy list.

Section 3 explains how to call a buddy.

2-3-1 Add an Entry

```
BUDDY LIST
> MANUAL NEW
  ALEX
  TOM
```

```
ENTER NAME
-----
ENTER MMSI
-----
```

```
ENTER NAME
BOB
ENTER MMSI
123456789
```

```
BOB
123456789
> STORE
  CANCEL
```

1. Select BUDDY LIST. The cursor is at MANUAL NEW. Press ENT.
2. Enter the buddy name, one character at a time (this may be alphanumeric) then press ENT or push the rotary knob repeatedly until the cursor moves to the MMSI entry line.
3. Enter the MMSI (this must be numeric) associated with that buddy name then press ENT.
4. The new buddy name and MMSI are displayed. Press ENT or push the rotary knob to store the new entry, which is displayed at the top of your buddy list.

NOTE: When the BUDDY LIST is full (20 entries), you can make a new entry and the buddy at the end of the list is automatically erased.

2-3-2 Edit an Entry

```
BUDDY LIST
> MANUAL NEW
  ALEX
  TOM
```

```
ALEX
> EDIT
  DELETE
```

```
EDIT NAME
ALEX
EDIT MMSI
112233445
```

```
ALEX
111223344
> STORE
  CANCEL
```

1. Select BUDDY LIST. Press ENT or push the rotary knob to display the list of entries.
2. Scroll down (if required) to the incorrect entry and press ENT.
3. Select EDIT. The cursor is at the first character of the name.
4. Edit the buddy name or, to edit only the MMSI, press ENT or push the rotary knob repeatedly until the cursor moves to the MMSI line.
5. When you are finished, press ENT or push the rotary knob (repeatedly if necessary) to display the next screen.
6. Press ENT or push the rotary knob to store the changes. The buddy list is displayed again. If more changes are required, repeat Steps 2 through 6. Otherwise, press ESC to exit.

2-3-3 Delete an Entry

```
BUDDY LIST
> MANUAL NEW
  ALEX
  TOM
```

```
BUDDY LIST
> MANUAL NEW
  ALEX
  TOM
```

```
TOM
> EDIT
  DELETE
```

```
DELETE BUDDY
TOM
> YES
  NO
```

1. Select BUDDY LIST. Press ENT or push the rotary knob to display the list of entries.
2. Scroll down (if required) to the entry you want to delete and press ENT.
3. Select DELETE then select YES.
4. The entry is deleted immediately and the buddy list is displayed again.

2-4 Local or Distance Sensitivity (LOCAL/DIST)

```
MENU SELECT
INFO DATA
BUDDY LIST
> LOCAL/DIST
```

Use LOCAL/DIST to improve the sensitivity of the receiver either locally (LOCAL) or over distances (DIST).

LOCAL is NOT recommended for use in open sea conditions. It's designed for use in areas of high radio noise; e.g. when you're close to a city.

See also SQL (Squelch Control) in Section 1.6.

2-4-1 Set Distance Sensitivity

```
SENSITIVITY
> DISTANT
LOCAL
```

1. Select LOCAL/DIST then select DIST.
2. Press ENT or push the rotary knob to activate the DIST setting. This disables local sensitivity and the menu is displayed again.

2-4-2 Set Local Sensitivity

```
SENSITIVITY
DISTANT
> LOCAL
```

1. Select LOCAL/DIST then scroll to LOCAL.
2. Press ENT or push the rotary knob to activate the LOCAL setting. This disables distance sensitivity and the menu is displayed again.

LOCAL is displayed on the LCD in reverse video, as a reminder that local sensitivity is selected.

2-5 Backlighting (BACKLIGHT) and Contrast (CONTRAST)

```
MENU SELECT
LOCAL/DIST
> BACKLIGHT
CONTRAST
```

Use BACKLIGHT to set the backlight levels for the LCD at a comfortable level.

- The microphone keypad backlighting is either ON or OFF.
- The DISTRESS key backlighting can't be switched off.

Use CONTRAST to set the contrast level for the LCD.

2-5-1 Set the Backlighting Level

```
BACKLIGHT
...
LO HI
PRESS ENT
```

1. Select BACKLIGHT.
2. Use CH + or CH - to select a comfortable backlight level.
3. Press ENT or push the rotary knob to confirm the new level and return to the menu.

Note: 705 handset option is only on or off.

2-5-2 Set the Contrast Level

```
CONTRAST
...
LO HI
PRESS ENT
```

1. Select CONTRAST.
2. Use CH + or CH - to select a comfortable contrast level.
3. Press ENT or push the rotary knob to confirm the new level and return to the menu.

2-6 GPS Data and Time (GPS/DATA)

```
MENU SELECT
  BACKLIGHT
  CONTRAST
  > GPS/DATA
```

If your vessel has an operational GPS navigation receiver, the radio automatically detects and updates the vessel position and the local time.

However, if the GPS navigation receiver is disconnected or absent, you can specify the vessel position and the local time manually, using the GPS/DATA option.

This information is important because it will be used if you transmit a DSC distress call.

2-6-1 Manually Enter Position and UTC Time (MANUAL)

NOTE: This function is available only when an operational GPS receiver is NOT connected.

```
GPS/DATA
> MANUAL
  SETTING
```

```
MANUAL LL
--'--'----N
--'--'----W
MAN --:--UTC
```

1. Select GPS/DATA, then MANUAL.
2. Enter the latitude, then the longitude, then the UTC.
3. Press ENT or push the rotary knob when all the information is correct.

The vessel's latitude and longitude are shown on the screen, with the UTC time. After entering your manual LL position, the prefix "M" in the normal GPS screen indicates a manual entry. The manual entries are cancelled if a real GPS position is received.

2-6-2 Local Time (TIME OFFSET)

The local time can be set by entering the time offset between UTC and local time as follows.

GPS/DATA
MANUAL
>SETTING

SETTING
> TIME OFFSET
TIME FORMAT
TIME DISPLY

TIME OFFSET
>+01:30

02:30PM LOC

1. Select GPS/DATA, then SETTING.
2. Select TIME OFFSET to enter the difference between UTC and local time. Half hour increments can be used with a maximum offset of ± 13 hours.

In this example, a difference of +1.5 hours has been entered and the local time is displayed with the suffix LOC.

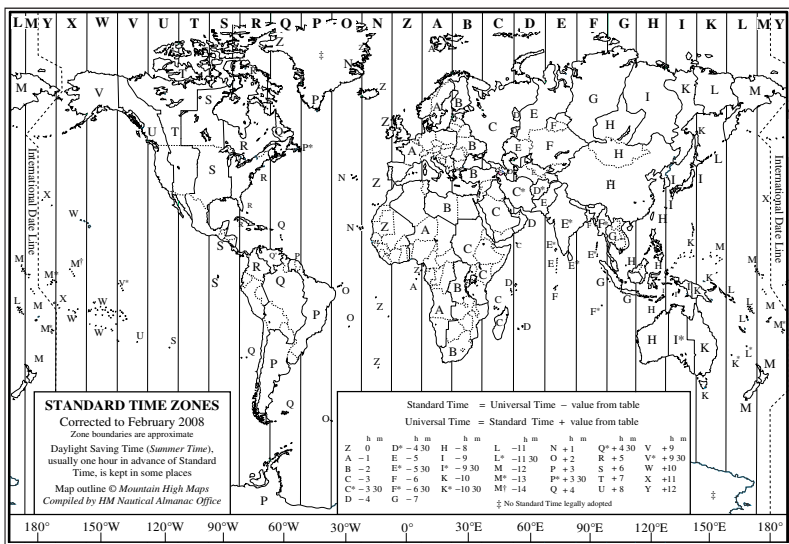

2-6-3 Time Format Options (TIME FORMAT)

Time can be shown in 12 or 24 hour format.

```
GPS/DATA
  MANUAL
  > SETTING
```

```
SETTING
  TIME OFFSET
  > TIME FORMAT
  TIME DISPLAY
```

```
TIME FORMAT
  > 12 Hr
  24 Hr
  07:15AM LOC
```

1. Select GPS/DATA, then SETTING.
2. Select TIME FORMAT.
3. Select 12 Hr or 24 Hr as desired. In this example, 12 hour format has been selected so the LCD shows the AM or PM suffix.

2-6-4 Time Display Options (TIME DISPLAY)

If you've entered the time manually as described in the previous sections, the time is shown ALWAYS with the prefix M.

However, if the vessel's position is being updated through a GPS navigation receiver, you can switch the time display ON or OFF as follows:

```
SETTING
  TIME OFFSET
  TIME FORMAT
  > TIME DISPLAY
```

```
TIME DISPLY
  ON
  > OFF
```

1. Select GPS/DATA, then SETTING.
2. Select TIME DISPLY.
3. Select ON or OFF as desired. In this example, OFF has been selected and so the LCD no longer shows the time.

If the time display is set ON, course and speed data are NOT displayed on the LCD (see section 2-6-6).

2-6-5 Position Display Options (LL display)

If you've entered the vessel position manually as described in the previous section, the vessel position is shown ALWAYS with the suffix M.

However, if the time is being updated through a GPS navigation receiver, you can switch the vessel position display ON or OFF as follows:

```
SETTING
  TIME FORMAT
  TIME DISPLAY
  > LL DISPLAY
```

```
LL DISPLAY
  ON
  > OFF
```

1. Select GPS/DATA, then SETTING.
2. Select LL DISPLAY.
3. Select ON or OFF as desired. In this example, OFF has been selected and the screen no longer shows the vessel position.

2-6-6 Course & Speed Display Options (COG/SOG)

Use this option to display course over ground (COG) and speed over ground (SOG) data on the screen.

```
SETTING
  TIME DISPLAY
  LL DISPLAY
  > COG/SOG
```

```
COG/SOG
  > ON
  OFF
```

1. Select GPS/DATA, then SETTING.
2. Select COG/SOG.
3. Select ON or OFF as desired. In this example, ON has been selected, so the screen shows the bearing and speed.

If COG/SOG is set ON, the time is NOT displayed on the screen (see section 2-6-4).

2-6-7 GPS Alert Options (ALERT)

The GPS alert is usually set to ON so that if the GPS navigation receiver is disconnected, the alarm sounds.

```
SETTING
  LL DISPLY
  COG/SOG
  > GPS ALERT
```

```
GPS ALERT
  > ON
  OFF
```

1. Select GPS/DATA, then SETTING.
2. Select GPS ALERT.
3. Select ON or OFF as desired.

2-7 GPS Simulator (GPS SIM)

The GPS Simulator is set to OFF whenever the radio is turned ON or whenever real GPS data is available through the COM port. However, if you want to test the GPS Simulator, turn it ON as follows:

```
MENU SELECT
  DSC SETUP
  RADIO SETUP
  > GPS SIM
```

1. Select GPS SIM, then select ON or OFF as desired.

Whenever the GPS Simulator is turned ON, simulated Speed Over Ground (SOG), Course Over Ground (COG), and LL position appear on the screen. This data is updated automatically during the simulation.

IMPORTANT: It's not possible to send a DSC transmission when you're in GPS Simulator mode.

2-8 Reset to Factory Defaults (RESET)

Use RESET to return every setting to the factory defaults EXCEPT all MMSI settings and the entries in your buddy list.

```
MENU SELECT
  RADIO SETUP
  GPS SIM
  > RESET
```

```
RESET RADIO?
ARE YOU SURE
  YES
  > NO
```

1. Select RESET. The radio asks for confirmation.
2. Select YES to reset the radio and return to the menu.

2-9 Subscribe or Un-Subscribe the 705 handset (HS SETTING)

Explorer725EU/725US only

The optional Handset functions with the base unit. It can not operate on it's own. Ensure the base unit is turned ON when using the handset.

You can use the VHF705 wireless handset to control and communicate with Explorer725 base unit from almost anywhere aboard your vessel. Before you first use the handset, it must first be subscribed to the base unit.

Subscribing the 705 Handset to the 725 base unit:

1. Ensure the handset is fully charged.
2. Turn the base unit on, and select "HS SETTING", "SUBSCRIBE", and "YES" from the SETUP menu.
"SUBSCRIBE WAITING" appears on the base unit LCD.

```
MENU SELECT
> HS SETTING
GPS SIM
RESET
```

```
HS SETTING
> SUBSCRIBE
CLEAR CODE
```

```
SUBSCRIBE
> YES
NO
```

```
SUBSCRIBE
WAITING
EXIT -> CANCEL
```

3. Turn the 705 handset ON then press and hold SCAN key to enter the 'subscribing' mode. The 705 will display "SUBSCRIBING" on its LCD to indicate it is waiting for response from the base unit.

Note: Your handset must be within operational range of the base unit.

4. After successful subscription, a "bi" tone will be emitted from the handset then display "CONNECTING, PLEASE WAIT" on the LCD. The 705 will then operate normally with the base unit.
5. Up to 2 handsets can be subscribed to one base unit. Before you subscribe the 2nd handset to the base unit, make sure the 1st handset is powered off. You can then follow the steps 1-4 to subscribe the 2nd handset.

Note: If subscribe is not successful, or you wish to un-subscribe a handset from your base unit to use on another base unit, it is recommended to clear the existing code first as follows:

To Un-Subscribe the 705 Handset from the 725 Base unit:

1. On the base unit, select "HS SETTING", "CLEAR CODE" and "YES" from the setup menu.

```
MENU SELECT
> HS SETTING
GPS SIM
RESET
```

```
HS SETTING
SUBSCRIBE
> CLEAR CODE
```

```
CLEAR CODE
> YES
NO
```

2. After a few seconds, the handset will display "SEARCH HOST" and no longer be subscribed to the base unit.

```
SIGNAL LOST!
SEARCH HOST
PLEASE WAIT
```

3. The handset can be subscribed to another base unit if needed.

Section 3 - Radio Setup Menu (RADIO SETUP)

Hold down CALL/MENU then scroll down and select **RADIO SETUP**.

Press ENT or push the rotary knob to show the **RADIO SETUP** menu options.

Sections 1-3 and 1-4 explain how to navigate around the menu and enter, save and change data.

3-1 The Radio Setup Menu Options (RADIO SETUP)

UIC	Select the channel bank (US only). See Section 3-2.
CH NAME	Edit or delete channel names. See Section 3-3.
RING VOLUME	Set the volume level of the incoming call notification beeps. See section 3-4.
KEY BEEP	Set the volume level of the beeps. See section 3-4.
INT SPEAKER	Turn the radio's internal speakers ON or OFF. See section 3-5.
WATCH MODE	Selects Dual or Tri watch scanning (US only). See section 3-6.
WX ALERT	Selects WX Alert scanning mode ON (on) or OFF (off) (US only). See section 3-7.
COM PORT	Select NMEA protocol for communications between the VHF radio and any other instruments. (721 / 725 only) See section 3-8.
BARO SENSOR	Select the barometric units, calibrate the sensor, turn the display ON or OFF. See Section 3-9.
TEMPERATURE	Select the temperature units, calibrate the sensor. See Section 3-10.
HAPPY FISH	Select the HAPPY FISH alarm to be ON or OFF. See Section 3-11.

3-2 Select the Channel Bank (UIC) (US only)

There is a choice of three channel banks; USA, International, or Canadian (see Appendix C for details).

RADIO SETUP
> UIC
CH NAME
RING VOLUME

UIC
> USA
INT'L
CANADA

1. Select RADIO SETUP.
2. The cursor is at UIC. Press ENT or push the rotary knob to display the list of channel banks.
3. Select the channel bank to use then press ENT or push the rotary knob to confirm the setting and return to the menu.

3-3 Change Channel Names (CH NAME)

The channel charts are listed in Appendix C with their default name tags. CH NAME gives you the option to edit or delete the channel name tags displayed on the screen.

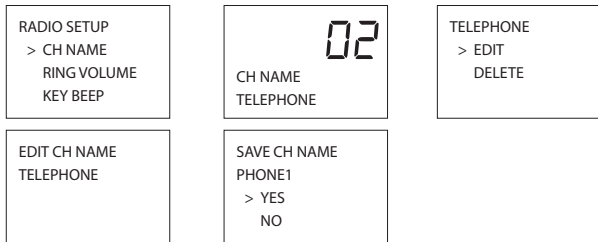

1. Select RADIO SETUP, then CH NAME.
2. Use CH + or CH - to step through the channels with their names until you see the channel name you want to change, then press ENT or push the rotary knob. In this example, the channel name TELEPHONE associated with channel 01 is being changed to PHONE1.
3. Select EDIT and press ENT or push the rotary knob to edit the existing name tag. Enter the new name over the existing name. It can be a maximum of 12 characters.
To delete the channel name, just select DELETE then press ENT or push the rotary knob.
4. Press ENT or push the rotary knob (repeatedly if necessary) to display the YES/NO confirmation.
5. Press ENT or push the rotary knob to confirm the new channel name tag or the deletion, then press ESC to return to the menu.

3-4 Ring and Beep Volume (RING VOLUME and KEY BEEP)

Set the volume level of the incoming signal beeps (RING VOLUME) and/or the error and warning beeps (KEY BEEP) as follows:

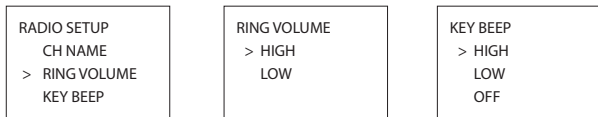

1. Select RADIO SETUP, then RING VOLUME or KEY BEEP as appropriate.
2. Select a HIGH or LOW volume. You can turn the beeps off completely by selecting KEY BEEP then OFF.
3. Press ENT or push the rotary knob to confirm the new volume setting and return to the menu.

3-5 Internal Speaker Connections (INT SPEAKER)

Switch the radio's internal speaker ON or OFF. (The external speaker is always ON if a speaker is plugged into the external speaker jack.)

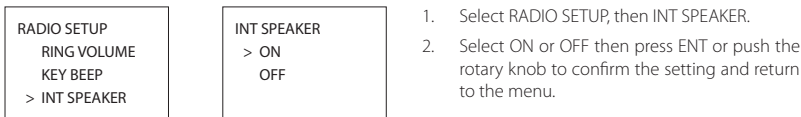

1. Select RADIO SETUP, then INT SPEAKER.
2. Select ON or OFF then press ENT or push the rotary knob to confirm the setting and return to the menu.

3-6 Set the Priority Channel (WATCH MODE)

If you have the 721/725 EU, watch mode is similar to a dual watch, scanning between the priority channel and the working channel. CH16 is the priority channel.

If you have the 721/725 US and are operating on USA or Canadian channel banks, you can set the priority channel to cover both CH16 and CH09 as well as the working channel, as follows:

RADIO SETUP
KEY BEEP
INT SPEAKER
> WATCH MODE

WATCH MODE
> ONLY 16CH
16CH+9CH

1. Select RADIO SETUP, then WATCH MODE.
2. Select ONLY 16CH for dual watch mode, or 16CH+9CH for tri watch mode.

3-7 Weather Alert (WX ALERT) (US only)

The NOAA provides several weather forecast channels on USA and Canadian channel banks. If severe weather such as storms or hurricanes are forecast, the NOAA broadcasts a weather alert on 1050 Hz. You can set up the radio to pick up weather alerts, as follows:

RADIO SETUP
INT SPEAKER
WATCH MODE
> WX ALERT

WX ALERT
ON
> OFF

1. Select RADIO SETUP, then WX ALERT.
2. Select ON then press ENT or push the rotary knob to confirm the setting and return to the menu. (If you select OFF, WX channel will not be watched during scanning.)
3. When a weather alert is broadcast, the alarm will sound. Press any key to hear the weather alert voice message.

3-8 NMEA or NAVBUS protocol (COM PORT) (721 / 725 only)

You can add the radio to a group of instruments using NMEA or NAVBUS protocol.

NAVBUS is automatically activated when present, so that data such as barometric pressure and history, temperature, DSC polling positions and distress data are available to any other Northstar instruments using NAVBUS. However, the barometric and temperature readings from the radio can be turned OFF if you prefer to use the readings from a different instrument.

Select your GPS data source to come from either NMEA or NAVBUS as follows:

3-8-1 NMEA CHECKSUM

RADIO SETUP
WATCH MODE
WX ALERT
> COM PORT

COM PORT
> NMEA
GPS SOURCE
BARO & TEMP

NMEA
CHECKSUM
> ON
OFF

1. Select RADIO SETUP, then COM PORT.
2. Select NMEA, then press ENT or push the rotary knob to show the CHECKSUM option.
3. CHECKSUM on is the usual setting. The cursor is at ON. Press ENT or push the rotary knob to confirm the setting and return to the menu.

3-8-2 NMEA GPS data source (GPS SOURCE)

RADIO SETUP
WATCH MODE
WX ALERT
> COM PORT

COM PORT
NMEA
> GPS SOURCE
BARO & TEMP

GPS SOURCE
> NMEA
NAVBUS

GPS SOURCE
NMEA
> ON
OFF

NMEA
CHECKSUM
> ON
OFF

1. Select RADIO SETUP, then COM PORT.
2. Select GPS source, then select NMEA.
3. The cursor is at ON. Press ENT or push the rotary knob to confirm the setting and show the CHECKSUM option.
4. CHECKSUM ON is the usual setting. The cursor is at ON. Press ENT or push the rotary knob to confirm the setting and return to the menu.

3-8-3 NAVBUS GPS data source (GPS SOURCE)

RADIO SETUP
WATCH MODE
WX ALERT
> COM PORT

COM PORT
NMEA
> GPS SOURCE
BARO & TEMP

GPS SOURCE
NMEA
> NAVBUS

GPS SOURCE
NAVBUS
> ON
OFF

1. Select RADIO SETUP, then COM PORT.
2. Select GPS source, then select NAVBUS.
3. The cursor is at ON. Press ENT or push the rotary knob to confirm the setting and return to the menu.

3-8-4 Use the 721/725 as barometric pressure and temperature data source (BARO & TEMP)

RADIO SETUP
WATCH MODE
WX ALERT
> COM PORT

COM PORT
NMEA
GPS SOURCE
> BARO & TEMP

BARO & TEMP
> ON
OFF

1. Select RADIO SETUP, then COM PORT.
2. Select BARO & TEMP.
3. The cursor is at ON. Select ON to have the radio provide the barometric and temperature data to other instruments connected. Select OFF to have another instrument to act as the source of this data.

3-9 Barometric Displays (BARO SENSOR)

A barometric sensor in the microphone measures air pressure changes, enabling the radio to provide three useful aids towards weather prediction and fishing conditions, particularly when you're close to large land masses. (See the information on the Happy Fish icon in Section 1-5.) The radio can show:

- a weather icon to indicate five different conditions (SUNNY, PARTLY CLOUDY, CLOUDY, RAINY, SNOW). The local air pressure trends combined with the local temperature determines which weather icon is displayed.
- a digital readout of air pressure (in mb or in/Hg).
- a graphical display of barometric pressure changes over the past consecutive 24 hours.

Information regarding Barometer, Weather and Happy Fish operation:

For these functions to operate correctly, the barometer sensor built into the microphone requires a permanent power connection. When the radio is turned off with the power knob on the radio, power continues to flow to the barometer sensor. This enables a 24 hour barometer trend to be collected and is used with the Happy Fish and Weather predictor.

Notes:

- Barometric data is maintained even if the radio is switched off (via the power knob).
- If the power supply to the radio is disconnected (vessel Battery Master is turned OFF), the barometer trend will cease and will re-start when power is re-applied.
- Happy Fish and Weather may not function, or may be inaccurate for several hours after initial power up.
- Baro history is not shown on Optional Handset (701/705) only Baro units.
- In open ocean conditions the weather icon can be less accurate than when close to large land masses.

3-9-1 Set the Barometric Units (BARO UNITS)

RADIO SETUP
WX ALERT
COM PORT
> BARO SENSOR

BARO SENSOR
> BARO UNITS
BARO DISPLY
CAL.

BARO UNIT
> MILLIBARS
INCHES-HG

1. Select RADIO SETUP, then BARO SENSOR.
2. The cursor is at BARO UNITS. Press ENT or press the rotary knob.
3. The cursor is at MILLIBARS. Press ENT or press the rotary knob to show barometric pressure in MILLIBARS or select INCHES-HG to show barometric pressure in inches of mercury.

3-9-2 Switch the Barometric Display ON or OFF (BARO DISPLY)

RADIO SETUP
WX ALERT
COM PORT
> BARO SENSOR

BARO SENSOR
BARO UNITS
> BARO DISPLY
BARO CAL.

BARO DISPLY
> LCD ON
LCD OFF

1. Select RADIO SETUP, then BARO SENSOR.
2. Select BARO DISPLY.
3. The cursor is at LCD OFF. Press ENT or press the rotary knob to switch OFF the barometric display on the base unit, or select LCD ON to show the barometric display on the base unit when turned off.

IMPORTANT: LCD OFF is the default. This minimises the current drain of the standby vessel battery to about 3mA average. If the barometric display is set to LCD ON the current drain is continuous at about 85mA.

3-9-3 Calibrate the Barometric Sensor (BARO CAL.)

The barometric functions and icons work best when calibrated to local conditions. The operating range is from 960mb to 1060mb.

RADIO SETUP
WX ALERT
COM PORT
> BARO SENSOR

BARO SENSOR
BARO UNITS
BARO DISPLY
> CAL

CAL
> ± 0.00 In-Hg

1. Select RADIO SETUP, then BARO SENSOR.
2. Select BARO CAL. then change the setting to match the reading on an accurate instrument nearby or the reading given by a local weather station.

3-10 Temperature Display (TEMPERATURE)

A temperature sensor in the base unit microphone measures air temperature changes.

NOTE: Temperature units can be displayed on the Optional Handset (701/705).

3-10-1 Set the Temperature Units (UNITS)

```
RADIO SETUP
COM PORT
BARO SENSOR
> TEMPERATURE
```

```
TEMPERATURE
> UNITS
CAL
```

```
TEMP SENSOR
> °C
°F
```

1. Select RADIO SETUP, then TEMPERATURE
2. The cursor is at UNITS. Press ENT or press the rotary knob.
3. The cursor is at °C. Press ENT or press the rotary knob to display the temperature in °C (Celsius) or select °F to show the temperature in Fahrenheit.

3-10-2 Calibrate the Temperature Reading (CAL.)

The temperature sensor works best when calibrated to local conditions.

```
RADIO SETUP
COM PORT
BARO SENSOR
> TEMPERATURE
```

```
TEMPERATURE
> UNITS
CAL
```

```
CAL
> ± 00.0 °F
```

1. Select RADIO SETUP, then TEMPERATURE.
2. Select CAL. then change the setting to match the reading on an accurate instrument nearby or the reading given by a local weather station.

3-11 HAPPY FISH Alarm ON or OFF

The Happy Fish Alarm can be turned ON or OFF.

```
RADIO SETUP
BARO SENSOR
TEMPERATURE
> HAPPY FISH
```

```
HAPPY FISH
> ON
OFF
```

1. Select RADIO SETUP, then HAPPY FISH.
2. Select HAPPY FISH OFF to disable all HAPPY FISH Alarms.

Section 4 - DSC SETUP Menu



A valid USER MMSI must be entered into this radio before these DSC functions can be used.
See Appendix E - Enter Your USER MMSI (USER MMSI).

4-1 What is DSC?

DSC (Digital Selective Calling) is a semi-automated method of establishing VHF, MF, and HF radio calls. It has been designated as an international standard by the IMO (International Maritime Organization) and is part of the GMDSS (Global Maritime Distress and Safety System).

Currently, you are required to monitor Distress Channel 16, but DSC will eventually replace listening watches on distress frequencies and will be used to broadcast routine and urgent maritime safety information.

DSC enables you to send and receive calls from any vessel or coast station that is equipped with DSC functionality, and within geographic range. Calls can be categorised as distress, urgency, safety, or routine, and DSC selects a working channel automatically.

4-2 DSC SETUP Menu Options

Hold down CALL/MENU then scroll and select the **DSC SETUP**.

Press ENT or push the rotary knob to show the following **DSC SETUP** menu options.

Sections 1.3 and 1.4 explain how to navigate around the menu and enter, save and change data.

USER MMSI	—	Check your user MMSI. See section 4-3. (If you do not have a user MMSI, see Appendix E.)
GROUP SETUP	—	Enter or change the name and/or details of a group. See section 4-4.
INDIV REPLY	—	Choose an automatic or manual response to calls. (721/725 US only) See section 4-5.
ATIS MMSI	—	Enter or change your ATIS MMSI (721/725 EU only) See section 4-6.
ATIS FUNC	—	Enable/disable the ATIS function (721/725 EU only) See section 4-6.
DSC FUNC	—	Turn the DSC operation ON/OFF (on/off). See section 4-7.
LL REPLY	—	Select the type of response to an LL polling request. See section 4-8.

4-3 Check Your User MMSI (USER MMSI)

You can display and read your user MMSI at any time.

1. Select DSC SETUP, then USER MMSI
2. The LCD shows your user name and MMSI.
3. If you have not already entered a User MMSI into your radio, see Appendix-E

4-4 Maintain Your Groups (GROUP SETUP)

Use GROUP SETUP to create, edit, or delete 1, 2, or 3 groups of frequently called people stored in alphanumeric order. A group MMSI always starts with 0.

4-4-1 Create a Group (GROUP SETUP)

1. Select DSC SETUP, then GROUP SETUP.
2. If this is the FIRST TIME that you're entering a group name, a line of nine zeros appears. Otherwise, any existing group names are displayed. Press ENT or push the rotary knob to display the input screen.
3. Enter the group name along the dashed line. The group name can be alphanumeric. Press ENT or push the rotary knob to confirm each correct entry and to move to the next digit. When you are finished, press ENT or push the rotary knob repeatedly until the cursor moves to the MMSI line.

```
DSC SETUP
  USER MMSI
> GROUP SETUP
  INDIV REPLY
```

```
GROUP SETUP
  > MANUAL NEW
      00000000
```

```
GROUP NAME
-----
GROUP MMSI
0-----
```

```
FISHER1
012345678
  > STORE
      CANCEL
```

If you make an error, select < and press ENT to backup and correct the entry (721/725 US) or CLR and ENT (721/725 EU).

4. Enter the group MMSI. The first number is always 0. Press ENT or push the rotary knob to confirm the entry.
5. The group name and group MMSI are shown in a confirmation screen. Press ENT or push the rotary knob to store the details and return to the GROUP SETUP screen.

4-4-2 Edit Group Name or Group MMSI

```
GROUP SETUP
  MANUAL NEW
> FISHER1
  FRIENDS1
```

```
FISHER1
  > EDIT
      DELETE
```

```
EDIT NAME
  > FISHER1
      EDIT MMSI
      012345678
```

```
FISHER2
012345678
  > STORE
      CANCEL
```

1. Select DSC SETUP, then GROUP SETUP. The existing group names are displayed. Select the group name that you want to edit.
2. The cursor is at EDIT. Press ENT or push the rotary knob to show the group name details. The cursor is at the first character of the group name.
3. Edit the new name or, to edit only the MMSI, press ENT or push the rotary knob repeatedly until the cursor moves to the MMSI line.
4. When you are finished, press ENT or push the rotary knob (repeatedly if necessary) to display the next screen.
5. Press ENT or push the rotary knob to store the changes and return to the GROUP SETUP screen.

4-4-3 Delete a Group

```
GROUP SETUP
  MANUAL NEW
> FISHER2
  FRIENDS1
```

```
FISHER2
  EDIT
  > DELETE
```

```
DELETE GROUP
FISHER2
  > YES
      NO
```

1. Select DSC SETUP, then GROUP SETUP.
2. Select the group that you want to delete.
3. Select DELETE and press ENT or press the rotary knob. The radio asks for confirmation.
4. Press ENT or push the rotary knob to delete the group and return to the GROUP SETUP screen.

4-5 Response to Individual Calls (INDIV REPLY) (US only)

You can respond to incoming individual calls with an automatic response or with a manual response.

- An automatic response sends an acknowledgement then sets the request link channel, ready for a conversation.
- A manual response asks if you want to acknowledge the call, and then asks if you want to converse with the caller.

```
DSC SETUP
USER MMSI
GROUP SETUP
> INDIV REPLY
```

```
INDIV REPLY
> AUTO
MANUAL
```

1. Select DSC SETUP, then select INDIV REPLY.
2. The cursor is at AUTO. Press ENT or press the rotary knob for an automatic response, or select MANUAL for a manual response.

4-6 ATIS MMSI & ATIS Functionality (EU only)

You MUST enter your ATIS MMSI to access ATIS functionality if you are navigating inland waterways within Europe. ATIS sends a digital message anytime that you release the PTT key. Inland waterways rules require 1 W Tx power on Channels 06, 08, 10, 11, 12, 13, 14, 15, 17, 71, 72, 74, and 77.

4-6-1 Enter or Edit Your ATIS MMSI

```
DSC SETUP
USER MMSI
GROUP SETUP
> ATIS MMSI
```

```
INPUT ATIS
MMSI
9-----
```

```
ATIS MMSI
9234567891
> STORE
CANCEL
```

```
ATIS MMSI
INPUT AGAIN
9-----
```

```
ATIS MMSI
9234567891
> STORE
CANCEL
```

To enter or edit your ATIS MMSI:

1. Select DSC SETUP, then ATIS MMSI.
2. If this is the FIRST TIME that you are entering your ATIS MMSI, a dashed line appears. Enter your ATIS MMSI along the dashed line. An ATIS MMSI always starts with the number 9. Press ENT or push the rotary knob to confirm each correct entry and to move to the next digit.

If you make an error, press CH - until < appears, then press ENT or push the rotary knob to backup and correct the entry.

If you're editing an existing ATIS MMSI, this will be displayed. Make the required changes.

3. Press ENT or push the rotary knob to store your ATIS MMSI.
4. Enter your ATIS MMSI again as a password check, then press ENT or push the rotary knob to permanently store the ATIS MMSI and return to the menu.

You can view your stored ATIS MMSI at anytime by selecting ATIS MMSI in the main menu.

4-6-2 Enable ATIS Functionality (ATIS FUNC) (EU only)

ATIS functionality will operate only after the ATIS MMSI has been entered (see previous section).

```
DSC SETUP
GROUP SETUP
ATIS MMSI
> ATIS FUNC
```

```
ATIS FUNC
> ON
OFF
```

1. Select DSC SETUP, then ATIS FUNC.
2. The cursor is at ON. Select ENT or push the rotary knob to enable the ATIS functionality and automatically disable DSC functionality. The ATIS annunciator appears on the screen.

It's not possible to have both ATIS ON and DSC ON simultaneously. When you enable one, the other will turn OFF. If DSC and ATIS are both OFF, you must turn DSC ON for normal DSC operation.

The annunciator on the LCD shows you the current mode: if the DSC annunciator is shown, DSC is operational; if the ATIS annunciator is shown, ATIS is operational.

4-7 DSC Functionality (DSC FUNC)

DSC functionality can be disabled but this is not recommended.

```
DSC SETUP
ATIS MMSI
ATIS FUNC
> DSC FUNC
```

```
DSC FUNC
> ON
OFF
```

1. Select DSC SETUP, then DSC FUNC.
2. The cursor is at ON. Press ENT or push the rotary knob to enable the DSC functionality and automatically disable ATIS functionality. The DSC annunciator appears on the screen.

It's not possible to have both ATIS ON and DSC ON simultaneously. When you enable one, the other will turn OFF. If DSC and ATIS are both OFF, you must turn DSC ON for normal DSC operation.

The annunciator on the LCD shows you the current mode: if the DSC annunciator is shown, DSC is operational; if the ATIS annunciator is shown, ATIS is operational.

4-8 Response Type to LL Polling Calls (LL REPLY)

You can set up the radio to respond to an LL polling request in one of three ways:

MANUAL reply manually or ignore to each incoming LL polling request from your buddies.

AUTO automatically replies to an incoming LL polling request from any of your buddies.

OFF ignores all incoming LL polling requests from your buddies.

```
DSC SETUP
ATIS FUNC
DSC FUNC
> LL REPLY
```

```
LL REPLY
> MANUAL
AUTO
OFF
```

1. Select DSC SETUP, then LL REPLY.
2. Select your mode of response and press ENT or push the rotary knob to confirm.

4-9 Mute the Notification Ringtone

If you have requested LL position data from any buddies, the 721/725 will notify you of any incoming data by sounding 2 friendly ringtones. If desired, you can mute this audible notification as follows:

```
DSC SETUP
DSC FUNC
LL REPLY
> LL RING
```

```
LL RING
> ON
OFF
```

1. Select DSC SETUP, then LL RING.
2. Select OFF (off) to mute the ringtones.
3. Press ENT to confirm your choice and return to the menu.

Section 5 - Send and Receive DSC Calls



WARNING

A valid USER MMSI must be entered into this radio before these DSC functions can be used.
See Appendix E - Enter Your USER MMSI (USER MMSI).

5-1 The DSC CALL Menu Options

Press CALL/MENU to show the **DSC CALL** menu.

Press ENT or push the rotary knob to show the following **DSC CALL** menu options.

Sections 1.3 and 1.4 explain how to navigate around the menu and enter, save and change data.

DSC CALL
INDIVIDUAL
> LAST CALL
GROUP

1. Press CALL to show the types of DSC call that can be made. Note that only four DSC call types can be shown at any one time on the screen.
2. Press + or - to scroll up and down the DSC call types until the cursor is positioned at the desired option. Then press ENT.

The following options are available through CALL key:

INDIVIDUAL

Make a individual call or acknowledgement to a new caller or a buddy.
See Section 5-2-1, 5-2-2, and 5-2-3.

LAST CALL

Show the details of the most recent incoming call.
See Section 5-2-4.

GROUP

Make a call to one of your three groups.
See Section 5-2-5.

ALL SHIPS

Make an All Ships call.
See Section 5-2-6.

CALL LOG

Show the details of the 20 most recent incoming calls.
See Section 5-2-7.

DIST LOG

Show the details of the 10 most recent distress calls.
See Section 5-2-8.

LL REQUEST

Request the LL position of a buddy.
See Section 5-2-9.

TRACK BUDDY

Operate Track Buddy functions.
See Section 5-2-10.

5-2 Call an Individual (INDIVIDUAL)

INDIVIDUAL
> ROUTINE
SAFETY
URGENCY

ROUTINE
> MANUAL NEW
BUDDY1
BUDDY2

MANUAL MMSI
0-----

112345678
INDIVIDUAL
ROUTINE
> SET CHANNEL

112345678
INDIVIDUAL
ROUTINE
> SEND?

112345678
INDIVIDUAL
ROUTINE
CALLING...

112345678
INDIVIDUAL
ROUTINE
WAITING ACK

INDIV ACK
112345678
PRESS PTT
ESC -> EXIT

You can call anyone who has a radio with DSC functionality. You can set the priority level of the DSC call to routine, safety or urgency. Choose:

- **ROUTINE** to make a routine call
- **SAFETY** to send safety information
- **URGENCY** only when there's a serious situation or problem that could lead to a distress situation

1. Press CALL/MENU to enter the DSC CALL menu, then select INDIVIDUAL to call another person.
2. The cursor is at ROUTINE. Press ENT or press the rotary knob to make a routine call or select to another priority level.
3. The cursor is at MANUAL NEW. Press ENT or press the rotary knob to call a person who's not in your buddy list; otherwise select the name of your buddy.

If you selected MANUAL NEW, enter the user MMSI and then press ENT or push the rotary knob.

4. Select the working channel and press ENT or press the rotary knob. (**NOTE:** If you're making a distress call, the radio goes to CH16 automatically.) Duplex channels can't usually be called and are automatically eliminated from the suggested call list. If the call is to a Coast Station, the radio will recognize this and select the correct channel.
5. The radio summarizes the call details and asks for confirmation to send the call (SEND?). Press ENT or push the rotary knob to send the call. The TX annunciator is displayed on the screen while the DSC call is being sent.
6. If the call is acknowledged (ACK), press PTT to talk. If there's no reply to a routine call, try again (see Section 5-3-1).

5-2-1 Retry a Routine Call

VHF721
SEND AGAIN?
> YES
NO

1. If there's no reply to your call after one minute (UNABLE TO ACKNOWLEDGE) the radio asks if you want to retry the call (SEND AGAIN?).
2. Select YES and press ENT or push the rotary knob to retry the call. If the call still can't be placed, the radio returns to normal operation.

5-2-2 Acknowledge an Individual Incoming Call

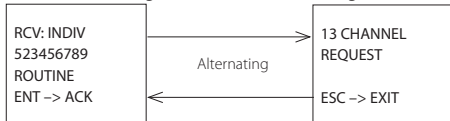

The Explorer 721/725 EU requires the operator to manually send an acknowledgement to the requesting radio. Press ENT or push the rotary knob to send an acknowledgement or press ESC to cancel.

The Explorer 721/725 US automatically sends an acknowledgement to the requesting radio within 10 seconds of receiving the call.

5-3 Call the Most Recent Caller (LAST CALL)



This facility is useful and used frequently.

1. Press CALL/MENU to enter the DSC CALL menu. LAST CALL is automatically selected. Press ENT or push the rotary knob to display the contact details of the most recent incoming call.
2. Select the working channel. Duplex channels can't usually be called and are automatically eliminated from the suggested call list. If the call is to a Coast Station, the radio will recognize this and select the correct channel.
3. The radio summarizes the call details and asks for confirmation to send the call (SEND?). Press ENT or push the rotary knob to send the call, and continue as explained in Section 5-3.

5-4 Call a Group (GROUP)



1. Press CALL/MENU to enter the DSC CALL menu, then select GROUP. The radio displays the names of your groups.
2. Select the group that you want to call (the Group MMSI must be set before making the call). Then set the channel and continue as explained in Section 5-3.

5-5 Call All Ships (ALL SHIPS)



1. Press CALL MENU to enter the DSC CALL menu, then select ALL SHIPS.

- The priority is set automatically to URGENCY, but you can change the priority level of the DSC call to routine, safety, urgency, or distress. Choose:
 - URGENCY** only when a serious situation or problem that could lead to a distress situation
 - SAFETY** to send safety information to all other vessels in range
 - ROUTINE** to make a routine call to all vessels (**US only**)
- Select the working channel and press ENT or press the rotary knob. Duplex channels can't usually be called and are automatically eliminated from the suggested call list.
- The radio asks for confirmation of the ALL SHIPS call (SEND?). Press ENT or push the rotary knob to select YES and send the call, and continue as explained in Section 5-3.

5-6 Call using the Call Log (CALL LOG)

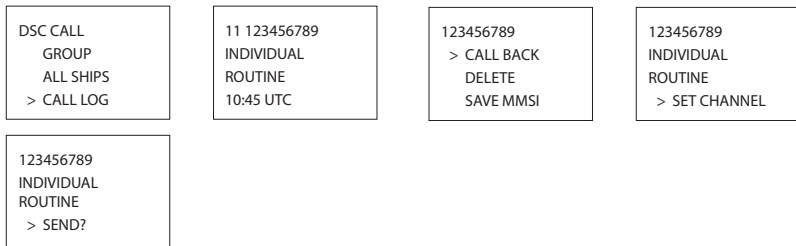

The Call Log contains the contact details for the 20 most recent incoming calls, so you call any of them again quickly.

- Press CALL/MENU to enter the DSC CALL menu, then select CALL LOG.
The radio displays the contact details for the most recent incoming call as the first entry (01) in the call log.
- Select the desired contact details. In this example, the contact details for the 11th most recent call are displayed.
To save this contact in your buddy list, select SAVE MMSI and press ENT or push the rotary knob. Enter a name for this contact. The logged MMSI is automatically displayed.
- Press CALL, then press ENT or push the rotary knob to confirm the call back, then set the working channel and press ENT or push the rotary knob to send the call. Continue as explained in Section 5-3.

5-7 Call using the Distress Log (DIST LOG)

The Distress Log contains the data for the 10 most recent relayed distress calls, so that you can call any of them quickly. Always try to make voice contact on CH16 first, as follows:

- Press CALL/MENU to enter the DSC CALL menu, then select DIST LOG.
- The most recently received distress call is the first entry (01) in the Distress Log. Select the entry that you want to call. The details are displayed over two screens that alternate every 1.5 seconds; the first screen shows the location and name or MMSI of the vessel in distress, the second screen shows the nature of the emergency (if specified) and the MMSI of the vessel that relayed the distress call.
- Select CALL BACK, set the channel and continue as explained in Section 5-3.

DSC CALL
ALL SHIPS
CALL LOG
> DIST LOG

DISTRESS
10:03 UTC
82°50.123 N
27°45.456 W

02 987654321
DISTRESS
PIRACY
ALL RELAY

987654321
> CALL BACK
DELETE
SAVE MMSI

987654321
INDIVIDUAL
ROUTINE
> SET CHANNEL

987654321
INDIVIDUAL
ROUTINE
> SEND?

5-8 Request the LL Position of a Buddy (LL REQUEST)

DSC CALL
CALL LOG
DIST LOG
> LL REQUEST

LL REQUEST
> SAM
VHF721
BUDDY #3

SAM
LL REQUEST
> SEND?

SAM
LL REQUEST

CALLING...

Channel name
SAM
LL REQUEST
WAITING ACK

1. Press CALL/MENU to enter the DSC CALL menu, then select LL REQUEST.
2. Select the buddy whose LL position you want to request then press ENT or push the rotary knob to send the request.
3. The working channel name is displayed while the radio waits for an acknowledgement from your buddy. Continue as explained in Section 5-3-1. If there's no reply after 1 minute the radio asks if you want to retry. Continue as explained in Section 5-3-2.

5-9 Track Your Buddy (TRACK BUDDY)

Use the TRACKLIST option to select the buddy (or buddies) whose position you want to track, specify the time interval through the INTERVAL option and then start the track. Alternatively, if the buddy and time are already set to your preference, just start tracking.

5-9-1 Select your Buddy

DSC CALL
DIST LOG
LL REQUEST
> TRACK BUDDY

TRACK BUDDY
START TRACK
> SET BUDDY
TRACKLIST

SET BUDDY
> BUDDY1 OFF
BUDDY2 ON
BUDDY3 OFF

SET BUDDY
BUDDY1
> ON
OFF

1. Press CALL/MENU to enter the DSC CALL menu, then select TRACK BUDDY.
2. Select SET BUDDY then select the buddy you want to track. You can set a maximum of 3 buddies to track.
3. Select ON to track that buddy or OFF to not track that buddy, and press ENT or push the rotary knob to confirm. (Repeat for the other two buddies if necessary.)

NOTE: To delete a buddy from the tracklist, just scroll to the buddy's name and press ENT or push the rotary knob. Select YES to confirm, then press ENT or push the rotary knob again.

5-9-2 Set the time interval

DSC CALL
DIST LOG
LL REQUEST
> TRACK BUDDY

TRACK BUDDY
SET BUDDY
TRACKLIST
> INTERVAL

INTERVAL
> 15 MINUTES
30 MINUTES
1 HOUR

1. Press CALL/MENU to enter the DSC CALL menu, then select TRACK BUDDY.
2. Select INTERVAL, then select the desired time interval. Press ENT or push the rotary knob to confirm.

5-9-3 Start tracking

DSC CALL
DIST LOG
LL REQUEST
> TRACK BUDDY

TRACK BUDDY
> START TRACK
SET BUDDY
TRACKLIST

START TRACK
BUDDY1 OFF
BUDDY2 ON
BUDDY3 OFF

START TRACK
> YES
NO

1. Press CALL/MENU to enter the DSC CALL menu, then select TRACK BUDDY.
2. Select START TRACK, then select YES. The START TRACK display changes to STOP TRACK. To stop tracking at any time, just select YES.

As soon as you start tracking, an LL Request is sent immediately on CH70 and your radio waits for acknowledgement of the (first) buddy's LL position to be displayed on your LCD.

Each of the selected buddies is polled for their LL positions at regular time intervals. When information is received, a friendly ringtone is sounded and the position is shown on the LCD. Press any key to cancel the display.

An LL position that is received is not stored in your radio's log, but is broadcast over NAVBUS to the chartplotters. Press any key to acknowledge or wait for the automatic 20 second time out.

NOTE: The Explorer 721/725 can receive and display the LL position data at normal or enhanced resolution.

5-9-4 Track Your Buddy (TRACK BUDDY) ADD

Add or Delete a Buddy as follows:

```
DSC CALL
DIST LOG
LL REQUEST
> TRACK BUDDY
```

```
TRACK BUDDY
START TRACK
SET BUDDY
> TRACKLIST
```

```
TRACKLIST
> ADD NEW
BUDDY1
BUDDY2
```

```
ADD NEW
> BUDDY3
BUDDY2
```

```
ADD NEW
> ADD NEW
BUDDY3
BUDDY2
```

1. Press CALL/MENT to enter the DSC CALL menu, then select TRACK BUDDY.
2. Select TRACK LIST, Any buddies already on the track list will be listed.
Note: To delete a buddy from the track list, select that buddy then press ENT, Select then press ENT again to delete.
3. Select ADD NEW to show your buddy list
4. Select the buddy then press ENT to add that buddy to the track list.

5-10 Receive an All Ships Call (RCV: ALL SHIP)

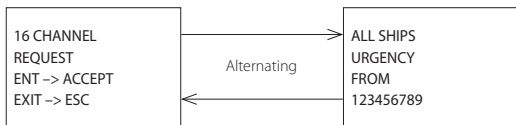

When you receive notification of an ALL SHIP call, press any key to cancel the alert. Press ENT to switch to the designated working channel, press ESC to return to original CH

The priority level and the user MMSI are displayed on the LCD. If the radio recognises the user MMSI as one of your buddies, the buddy's name is displayed in place of the user MMSI.

No acknowledgement is required. Press PTT to initiate voice contact on CH16 and then switch to a working channel.

The call data is stored in the Call Log (see Section 5-7).

5-11 Receive an Individual Call (RCV: INDIV)

```
RCV: INDIV
VHF721
ROUTINE
ENT -> ACK
```

```
12 CHANNEL  
REQUEST  
  
ESC -> EXIT
```

When you receive notification of an INDIV call, press any key to cancel the alert.

The radio manually selects the channel designated in the incoming call by pressing the ENT key. INDIV calls are almost always routine priority.

If the radio recognises the user MMSI as one of your buddies, the buddy's name is displayed in place of the user MMSI.

The 721/725 US responds automatically but the 721/725 EU prompts you to press ENT or push the rotary knob to acknowledge the incoming call.

The caller should respond to your acknowledgement by making voice contact on the designated channel. If this doesn't happen, you can press PTT to initiate voice contact instead.

The call data is stored in the Call Log (see Section 5-7).

5-12 Receive a Group Call (RCV: GROUP)

RCV: GROUP
GP: RD GROUP
VHF721
ESC -> EXIT

When you receive notification of a GROUP call, press any key to cancel the alert.

The radio automatically selects the channel designated in the incoming call.

The priority level is always routine, and the group is identified on the screen. The group will be one of the three groups of frequently called people that you set up earlier (see Section 4-3).

You don't need to send an acknowledgement. If desired, press PTT to initiate voice contact on the designated channel.

The call data is stored in the Call Log (see Section 5-7).

5-13 Receive a Geographic Call (RCV: GEOGRAPH)

GEOGRAPHICAL
ROUTINE
VHF721
ENT -> ACCEPT

Alternating

16 CHANNEL
REQUEST
ESC -> EXIT

A geographic call is sent to all vessels within a specific geographic boundary area.

When you receive notification of a GEOGRAPH call, press any key to cancel the alert.

The radio will select the channel designated in the incoming call by pressing the ENT key.

The user MMSI or name are displayed on the screen. If the radio recognises the user MMSI as one of your buddies, the buddy's name is displayed in place of the user MMSI.

Monitor the working channel for an announcement from the calling vessel.

5-14 Receive a Polled Position Call (RCV: POSITION)

POSITION ACK
BUDDY
ESC -> EXIT

Alternating

POSITION ACK
12:45 UTC
82°50.003'N
27°45.543'W

When you receive GPS position data from a buddy in response to your LL request (see Section 5-9), you're recommended to make a written note of the position, especially if it's a good fishing position.

If enhanced LL position information is available from your buddy, it's shown on the LCD until the display changes.

Section 6 - Distress Calls



WARNING

A valid USER MMSI must be entered into this radio before these DSC functions can be used.
See Appendix E - Enter Your USER MMSI (USER MMSI).

6-1 Send a Distress Call

1. Open the red cover labelled DISTRESS.

If time is available to specify the nature of the distress, go to step 2. Otherwise, go directly to step 3.

DISTRESS CALL
> ABANDONING
PIRACY
OVER BOARD

DISTRESS CALL
> PIRACY
HOLD DISTRESS
2 SECONDS..

DISTRESS CALL
SENT! WAIT..
PRESS ESC
TO CANCEL...

2. Press the DISTRESS key (located under the red cover) to display the following categories. Scroll to the category that describes your situation, then press ENT or push the rotary knob:

UNDESIGNATED	(Undesignated)
FIRE	(Fire)
FLOODING	(Flooding)
COLLISION	(Collision)
GROUNDING	(Grounding)
LISTING	(Listing)
SINKING	(Sinking)
ADRIFT	(Adrift)
ABANDONING	(Abandoning)
PIRACY	(Piracy)
OVER BOARD	(Over Board)

3. Hold down the DISTRESS key for about 3 seconds, until you see the distress call message (DISTRESS CALL SENT!) on the LCD. The whole display starts to flash and beep loudly.

The distress call repeats five times continuously. It then repeats randomly every 3.5 to 4.5 minutes until a distress acknowledgement (DISTRESS ACK) is received from a search and rescue authority or until you cancel the distress call manually.

The radio selects CH16 automatically so that you can hear any incoming voice contacts from search and rescue authorities or other vessels within range.

Press ESC if you need to cancel the distress call. This is the only key that operates in distress mode.

6-2 Receive a Distress Acknowledgement (DISTRESS ACK)

For a Distress Acknowledgement (DISTRESS ACK) sent from the Search and Rescue (SAR) authorities of your country, your radio automatically cancels Distress Mode transmissions and CH16 appears. Press PTT to establish voice contact with the Search and Rescue (SAR) authority.

The Search and Rescue (SAR) authorities of your country are the only instance allowed to send a Distress Acknowledgement (DISTRESS ACK).

6-3 Receive a Distress Call (RCV: DISTRESS)

123456789
DISTRESS
FLOODING
ESC -> EXIT

123456789
10:34 UTC
82°50.003'N
27°45.543'W

An alert sounds when a distress call (DISTRESS!) is received. Press any key to cancel the alert. You don't need to send an acknowledgement.

The radio automatically selects CH16 and displays the details of the distress call on the screen. Press PTT to establish voice contact.

The details are displayed over two screens that alternate every 1.5 seconds; the first screen shows the user MMSI and nature of the emergency (if specified), the second screen shows the time and the location (if specified). If the location and time aren't specified, they're replaced with sequences of 9s and 8s respectively.

The radio is capable of receiving enhanced LL position data if the vessel transmitting the distress call is sending this. This provides the position of the distressed vessel to within 60 ft (20 m).

6-4 Receive a Distress Relay (RCV: DISTRESS RELAY)



An alert sounds when a distress relay (DISTRESS RELAY) is received from an individual or from an All Ships transmission. Press any key to cancel the alert.

Try to make voice contact with the calling vessel. Maintain a listening watch on CH16 and standby to lend assistance.

6-5 Relay a Distress Call from the Distress Log (RELAY)

You can relay a Distress Call in your Distress Log to an Individual or to All Ships.

1. Press CALL/MENU to enter the DSC CALL menu, then select DIST LOG (see Section 5.8).

987654321
DELETE
SAVE MMSI
> RELAY

RELAY
> INDIV RELAY
ALL RELAY

INDIV RELAY
> MANUAL NEW
BUDDY1
BUDDY2

2. The most recently received distress call is the first entry (01) in the Distress Log. Select the distress call that you want to relay, then select RELAY.
3. Now select either:
 - INDIV RELAY to relay the distress call to an individual and select MANUAL NEW if the person is not in your buddy list, otherwise scroll to the name of your buddy. Press ENT or push the rotary knob. (If you selected MANUAL NEW, you need to enter the user MMSI then press ENT or push the rotary knob.)
 - ALL RELAY to relay the distress call to All Ships then press ENT or push the rotary knob.
4. The radio automatically selects CH16 (for all relay) or manually set the working CH (INDIV RELAY) and displays the details of the distress call on the screen.
5. Press ENT or push the rotary knob to relay the Distress Call.

Appendix A - Technical Specifications

Northstar Explorer 721/725US and 721/725EU

GENERAL

Power Supply:	13.6 V DC.
Current drain: Transmit	6 A at 25 W Tx / 1.5 A at 1 W Tx
Current drain: Receive	Less than 250 mA in standby
Baro sampling (radio off):	Less than 3 mA, 85 mA in active standby
Useable channels:	International, USA, Canada, Weather (country specific)
Mode:	16K0G3E (FM) / 16K0G2B (DSC)

PHYSICAL

LCD display (viewing):	40 (H) x 48 (W) mm FSTN 4 x 12 character
Contrast control:	Yes
Backlight control:	Yes
Antenna connector:	SO-239 (50 ohm)
Temperature Range:	-15°C to +55°C (for EU), -20°C to +50°C (for US)
Waterproof:	JIS-7
Dimensions:	161 (W) x 75 (H) x 147 (D) mm - without bracket
Weight:	3.0 lbs (1.36 kg) without microphone
Frequency stability:	+/- 10ppm
Frequency control:	PLL
GPS/NMEA input:	Yes
GPS data sentences can be received:	RMC, GGA, GLL, GNS.
NMEA output:	Yes
NMEA output sentences:	DSC (for DSC call), DSE (for enhanced position).
Comm. port:	4800 baud NMEA, 38400 baud NAVBUS
DSC:	Yes
DSC mode: USCG SC101	721US/725US
DSC Class D	721EU/725EU and Canada (Commercial)
DSC Class S	Canada (Recreational)

FEATURES

Flush mounting kit:	Yes
Dust cover:	Yes
Rotary channel selector:	Yes
Local/Distant control:	Yes
Position polling:	Yes

Track Your Buddy:	Yes
Group Call:	Yes
Call logs:	Yes - 20 individual and 10 distress
Barometer, Temperature and Happy Fish:	Yes
Channel Naming:	Yes
Tri watch, favorite channel scan:	Yes
All scan:	Yes
User programmable MMSI:	Yes (User MMSI and ATIS (721/725 EU)
MMSI and NAME directory:	Yes - 20 numbers & group

TRANSMITTER

Frequency:	156.025 - 157.425 MHz
Output power:	25 W / 1 W selectable
Transmitter protection:	Open / short circuit of antenna
Max Freq deviation:	+/- 5 kHz
Spurious & harmonics:	better than @ 2.5 W
Modulation distortion:	Less than 4% @ 1 kHz for a +/-3 kHz deviation

RECEIVER

Frequency:	156.025 - 163.275 MHz
12 dB SINAD sensitivity:	0.25 uV (distant) / 2.5 uV (local)
Adjacent CH selectivity:	more than 70 db
Spurious response:	more than 70 db
Intermodulation rejection ratio:	more than 68 db
Residual Noise level:	more than -40 db unscelched
Audio output power:	2 W (with 8 ohm at 10% distortion) 4 W with 4 ohm external speaker
Compass safe distance:	1.5' (0.5 m)

OPTIONAL HANDSET

Wired - with 3mtr cable:

VHF701US	Works only with Explorer 721US
VHF701EU	Works only with Explorer 721EU

Wireless - with desktop charger:

VHF705US	Works only with Explorer 725US
VHF705EU	Works only with Explorer 725EU
Power source	Built-in 3.7V 750mAH Lithium Ion rechargeable battery
Wireless:	ISM 2.4GHz FHSS
Range:	Approximately 150mtrs in ideal conditions

Specifications are subject to change without notice.

Appendix B - Troubleshooting

1. The transceiver will not power up.

A fuse may have blown OR there is no voltage getting to the transceiver.

- Check the power cable for cuts, breaks, or squashed sections.
- After checking the wiring, replace the 7 Amp fuse (a spare fuse is supplied).
- Check the battery voltage. This must be greater than 10.5 V.

2. The transceiver blows the fuse when the power is switched on.

The power wires may have been reversed.

- Check that the red wire is connected to the positive battery terminal, and the black wire is connected to the negative battery terminal.

3. The speaker makes popping or whining noises when the engine is running.

Electrical noise may be interfering with the transceiver.

- Re-route the power cables away from the engine.
- Add a noise suppressor to the power cable.
- Use resistive spark plug wires and/or use an alternator whine filter.

4. No sound from the external speaker.

- Check that the external speaker cable is physically connected.
- Check the soldering of the external speaker cable.

5. Transmissions are always on low power, even when high (HI) power is selected.

The antenna may be faulty.

- Test the transceiver with a different antenna.
- Have the antenna checked out.

Insufficient battery power.

- check the battery wiring to the radio.
- check the battery voltage.

6. Battery symbol is displayed.

The power supply is too low.

- Check the battery wiring to the radio.
- Check the battery voltage.

7. No position information is displayed.

The GPS cable may be faulty or the GPS setting may be incorrect.

- Check that the GPS cable is physically connected.
- Check the polarity of the GPS cable.
- Check the baud rate setting of the GPS if applicable. The baud rate setting should be 4800 for NMEA or 38400 for NAVBUS. Parity should be set to NONE.

Appendix C - VHF Marine Channel Charts

C-1 International Channel Chart

CH	TX (MHz)	RX (MHz)	MODE	TRAFFIC TYPE	SHIP TO SHIP	SHIP TO SHORE	NAME TAG	REMARK
01	156.050	160.650	D	Public Correspondence	No	Yes	TELEPHONE	
02	156.100	160.700	D	Public Correspondence	No	Yes	TELEPHONE	
03	156.150	160.750	D	Public Correspondence	No	Yes	TELEPHONE	
04	156.200	160.800	D	Port Operations	No	Yes	PORT OP	
05	156.250	160.850	D	Port Operations, Selected VTS Areas	No	Yes	PORT OPS/VTS	
06	156.300	156.300	S	Inter-ship Safety	Yes	No	SAFETY	
07	156.350	160.950	D	Port Operations	No	Yes	PORT OPS	
08	156.400	156.400	S	Commercial (inter-ship only)	Yes	No	COMMERCIAL	
09	156.450	156.450	S	Recreational Calling Channel	Yes	Yes	CALLING	
10	156.500	156.500	S	Commercial	Yes	Yes	COMMERCIAL	
11	156.550	156.550	S	Commercial, VTS in Selected Areas	Yes	Yes	VTS	
12	156.600	156.600	S	Port Operations, Selected VTS Areas	Yes	Yes	PORT OPS/VTS	
13	156.650	156.650	S	Inter-ship Navigation Safety (bridge-to-bridge)	Yes	No	BRIDGE COM	
14	156.700	156.700	S	Port Operations, Selected VTS Areas	Yes	Yes	PORT OPS/VTS	
15	156.750	156.750	S	Port Operations	Yes	Yes	PORT OPS	⊙ 1W only
16	156.800	156.800	S	International Distress, Safety, and Calling	Yes	Yes	DISTRESS	
17	156.850	156.850	S	State Controlled	Yes	Yes	SAR	⊙ 1W only
18	156.900	161.500	D	Port Operations	No	Yes	PORT OPS	
19	156.950	161.550	D	Commercial	No	Yes	SHIP - SHORE	
20	157.000	161.600	D	Port Operations	No	Yes	PORT OPS	
21	157.050	161.650	D	Port Operations	No	Yes	PORT OPS	
22	157.100	161.700	D	Port Operations	No	Yes	PORT OPS	
23	157.150	161.750	D	Public Correspondence	No	Yes	TELEPHONE	
24	157.200	161.800	D	Public Correspondence	No	Yes	TELEPHONE	
25	157.250	161.850	D	Public Correspondence	No	Yes	TELEPHONE	
26	157.300	161.900	D	Public Correspondence	No	Yes	TELEPHONE	
27	157.350	161.950	D	Public Correspondence	No	Yes	TELEPHONE	
28	157.400	162.000	D	Public Correspondence	No	Yes	TELEPHONE	
60	156.025	160.625	D	Public Correspondence	No	Yes	TELEPHONE	
61	156.075	160.675	D	Port Operations	No	Yes	PORT OPS	

62	156.125	160.725	D	Port Operations	No	Yes	PORT OPS	
63	156.175	160.775	D	Port Operations	No	Yes	PORT OPS	
64	156.225	160.825	D	Public Correspondence	No	Yes	TELEPHONE	
65	156.275	160.875	D	Port Operations	No	Yes	PORT OPS	
66	156.325	160.925	D	Port Operations	No	Yes	PORT OPS	
67	156.375	156.375	S	Commercial, bridge-to-bridge	Yes	No	BRIDGE COM	
68	156.425	156.425	S	Boat Operations, Recreational	Yes	No	SHIP - SHIP	
69	156.475	156.475	S	Port Operations	Yes	Yes	PORT OPS	
70	156.525	156.525		Digital Selective Calling - DSC	-----	-----	DSC	③
71	156.575	156.575	S	Port Operations	Yes	Yes	PORT OPS	
72	156.625	156.625	S	Inter-ship	Yes	No	SHIP - SHIP	
73	156.675	156.675	S	Port Operations	Yes	Yes	PORT OPS	
74	156.725	156.725	S	Port Operations	Yes	Yes	PORT OPS	
77	156.875	156.875	S	Inter-ship	Yes	No	SHIP - SHIP	
78	156.925	161.525	D	Non-Commercial	No	Yes	SHIP - SHORE	
79	156.975	161.575	D	Commercial	No	Yes	SHIP - SHORE	
80	157.025	161.625	D	Commercial	No	Yes	SHIP - SHORE	
81	157.075	161.675	D	Port Operations	No	Yes	PORT OPS	
82	157.125	161.725	D	Port Operations	No	Yes	PORT OPS	
83	157.175	161.775	D	Public Correspondence	No	Yes	TELEPHONE	
84	157.225	161.825	D	Public Correspondence	No	Yes	TELEPHONE	
85	157.275	161.875	D	Public Correspondence	No	Yes	TELEPHONE	
86	157.325	161.925	D	Public Correspondence	No	Yes	TELEPHONE	
87	157.375	157.375	S	Port Operations	No	Yes	PORT OPS	
88	157.425	157.425	S	Port Operations	No	Yes	PORT OPS	

Special Notes on International Channel Usage

- ①. LOW POWER (1W) only.
- ②. LOW POWER (1W) initially. Override to HIGH POWER by holding down H/L key before transmitting. Used normally in bridge-to-bridge communications.
- ③. Channel 70 is designated for use exclusively for Digital Selective Calling (DSC), such as Distress, Safety, and Ship Calls. No voice communication is allowed on CH70. This channel is only available on DSC enabled radios.

Note: The INTERNATIONAL mode is not legal for use in U.S. or Canada waters.

KEY: S = Simplex operating channel; D = Duplex operating channel.

C-2 USA Channel Chart

CH	TX (MHz)	RX (MHz)	MODE	TRAFFIC TYPE	SHIP TO SHIP	SHIP TO SHORE	NAME TAG	REMARK
01A	156.050	156.050	S	Port Operations, Selected VTS Areas	Yes	Yes	PORT OPS/VTS	
03A	156.150	156.150	S	US Government, Coast Guard	Yes	Yes	UNAUTHORIZED	④
05A	156.250	156.250	S	Port Operations, Selected VTS Areas	Yes	Yes	PORT OPS/VTS	
06	156.300	156.300	S	Inter-ship Safety	Yes	No	SAFETY	
07A	156.350	156.350	S	Commercial	Yes	Yes	COMMERCIAL	
08	156.400	156.400	S	Commercial (inter-ship only)	Yes	No	COMMERCIAL	
09	156.450	156.450	S	Recreational Calling Channel	Yes	Yes	CALLING	
10	156.500	156.500	S	Commercial	Yes	Yes	COMMERCIAL	
11	156.550	156.550	S	Commercial, VTS in Selected Areas	Yes	Yes	VTS	
12	156.600	156.600	S	Port Operations, Selected VTS Areas	Yes	Yes	PORT OPS/VTS	
13	156.650	156.650	S	Inter-ship Navigation Safety (bridge-to-bridge), 1W with Power-up	Yes	No	BRIDGE COM	③ 1W
14	156.700	156.700	S	Port Operations, Selected VTS Areas	Yes	Yes	PORT OPS/VTS	
15	---	156.750	S	Environmental	-----	-----	ENVIRONMENTAL	② RX only
16	156.800	156.800	S	International Distress, Safety, and Calling	Yes	Yes	DISTRESS	
17	156.850	156.850	S	State Controlled	Yes	Yes	SAR	① 1W only
18A	156.900	156.900	S	Commercial	Yes	Yes	COMMERCIAL	
19A	156.950	156.950	S	Commercial	Yes	Yes	COMMERCIAL	
20	157.000	161.600	D	Port Operations, Canadian Coast Guard	No	Yes	PORT OPS	
20A	157.000	157.000	S	Port Operations	Yes	Yes	PORT OPS	
21A	157.050	157.050	S	U.S. Government, Canadian Coast Guard	Yes	Yes	UNAUTHORIZED	④
22A	157.100	157.100	S	Coast Guard Liaison	Yes	Yes	COAST GUARD	
23A	157.150	157.150	S	U.S. Government, Coast Guard	Yes	Yes	UNAUTHORIZED	④
24	157.200	161.800	D	Public Correspondence, Marine operator	No	Yes	TELEPHONE	
25	157.250	161.850	D	Public Correspondence, Marine operator	No	Yes	TELEPHONE	
26	157.300	161.900	D	Public Correspondence, Marine operator	No	Yes	TELEPHONE	
27	157.350	161.950	D	Public Correspondence, Marine operator	No	Yes	TELEPHONE	
28	157.400	162.000	D	Public Correspondence, Marine operator	No	Yes	TELEPHONE	
61A	156.075	156.075	S	U.S. Government, Canadian Coast Guard	Yes	Yes	UNAUTHORIZED	④
63A	156.175	156.175	S	Port Operations, VTS in Selected Areas	Yes	Yes	PORT OPS/VTS	
64A	156.225	156.225	S	U.S. Government, Canadian Commercial Fishing	Yes	Yes	UNAUTHORIZED	④
65A	156.275	156.275	S	Port Operations	Yes	Yes	PORT OPS	
66A	156.325	156.325	S	Port Operations	Yes	Yes	PORT OPS	

67	156.375	156.375	S	Commercial, bridge-to-bridge, 1W with Power-up	Yes	No	BRIDGE COM	③ 1W
68	156.425	156.425	S	Boat Operations, Recreational	Yes	No	SHIP - SHIP	
69	156.475	156.475	S	Boat Operations, Recreational	Yes	Yes	PLEASURE	
70	156.525	156.525		Digital Selective Calling - DSC	-----	-----	DSC	⑥
71	156.575	156.575	S	Boat Operations, Recreational	Yes	Yes	PLEASURE	
72	156.625	156.625	S	Boat Operations, Recreational	Yes	No	SHIP - SHIP	
73	156.675	156.675	S	Port Operations	Yes	Yes	PORT OPS	
74	156.725	156.725	S	Port Operations	Yes	Yes	PORT OPS	
77	156.875	156.875	S	Port Operations	Yes	Yes	PORT OPS	① 1W only
78A	156.925	156.925	S	Boat Operations, Recreational	Yes	No	SHIP - SHIP	
79A	156.975	156.975	S	Commercial	Yes	Yes	COMMERCIAL	
80A	157.025	157.025	S	Commercial	Yes	Yes	COMMERCIAL	
81A	157.075	157.075	S	U.S. Government, Environmental Protection Agency Operations	Yes	Yes	UNAUTHORIZED	④
82A	157.125	157.125	S	U.S. Government, Canadian Coast Guard	Yes	Yes	UNAUTHORIZED	④
83A	157.175	157.175	S	U.S. Government, Canadian Coast Guard	Yes	Yes	UNAUTHORIZED	④
84	157.225	161.825	D	Public Correspondence, Marine Operator	No	Yes	TELEPHONE	
85	157.275	161.875	D	Public Correspondence, Marine Operator	No	Yes	TELEPHONE	
86	157.325	161.925	D	Public Correspondence, Marine Operator	No	Yes	TELEPHONE	
87	157.375	157.375	S	Port Operations	No	Yes	PORT OPS	
88	157.425	157.425	S	Port Operations	No	Yes	PORT OPS	
88A	157.425	157.425	S	Commercial, Inter-ship Only	Yes	No	COMMERCIAL	

Special Notes on USA Channel Usage

- ①. LOW POWER (1 W) only.
- ②. Receive Only.
- ③. LOW POWER (1 W) initially. Override to HIGH POWER by holding down H/L key before transmitting. Used normally in bridge-to-bridge communications.
- ④. Lightly shaded simplex channels 03A, 21A, 23A, 61A, 64A, 81A, 82A, and 83A cannot be lawfully used in U.S. waters unless special authorization is obtained from the U.S. Coast Guard. Not for use by the general public.
- ⑤. The letter "A" illuminated by the channel number indicates the USA channel is simplex. This same channel is always duplex when selecting International. There is no "A" reference for International channels. The letter "B" is only used for some Canadian "Receive only" channels.
- ⑥. Channel 70 is designated for use exclusively for Digital Selective Calling (DSC), such as Distress, Safety, and Ship Calls. No voice communication is allowed on CH70. This channel is only available on DSC enabled radios.

KEY: S = Simplex operating channel; D = Duplex operating channel.

C-3 CANADA Channel Chart

CH	TX (MHz)	RX (MHz)	MODE	TRAFFIC TYPE	SHIP TO SHIP	SHIP TO SHORE	NAME TAG	REMARK
01	156.050	160.650	D	Public Correspondence	No	Yes	TELEPHONE	
02	156.100	160.700	D	Public Correspondence	No	Yes	TELEPHONE	
03	156.150	160.750	D	Public Correspondence	No	Yes	TELEPHONE	
04A	156.200	156.200	S	Canadian Coast Guard, SAR	Yes	Yes	CANADIAN CG	
05A	156.250	156.250	S	Port Operations, VTS in Selected Areas	Yes	Yes	PORT OPS/VTS	
06	156.300	156.300	S	Inter-ship Safety	Yes	No	SAFETY	
07A	156.350	156.350	S	Commercial	Yes	Yes	COMMERCIAL	
08	156.400	156.400	S	Commercial (inter-ship only)	Yes	No	COMMERCIAL	
09	156.450	156.450	S	Recreational Calling Channel	Yes	Yes	CALLING	
10	156.500	156.500	S	Commercial	Yes	Yes	COMMERCIAL	
11	156.550	156.550	S	Commercial, VTS in Selected Areas	Yes	Yes	VTS	
12	156.600	156.600	S	Port Operations, VTS in Selected Areas	Yes	Yes	PORT OPS/VTS	
13	156.650	156.650	S	Inter-ship Navigation Safety (bridge-to-bridge) 1W with power-up	Yes	No	BRIDGE COM	③ 1W
14	156.700	156.700	S	Port Operations, VTS in Selected Areas	Yes	Yes	PORT OPS/VTS	
15	156.750	156.750	S	Commercial	Yes	Yes	COMMERCIAL	① 1W only
16	156.800	156.800	S	International Distress, Safety, and Calling	Yes	Yes	DISTRESS	
17	156.850	156.850	S	State Controlled	Yes	Yes	SAR	① 1W only
18A	156.900	156.900	S	Commercial	Yes	Yes	COMMERCIAL	
19A	156.950	156.950	S	Canadian Coast Guard	Yes	Yes	CANADIAN CG	
20	157.000	161.600	D	Canadian Coast Guard	No	Yes	CANADIAN CG	① 1W only
21	157.050	161.650	D	Port Operations	No	Yes	PORT OPS	
21A	157.050	157.050	S	U.S. Government, Canadian Coast Guard	Yes	Yes	UNAUTHORIZED	
21B	---	161.650	S	Port Operations	-----	-----	PORT OPS	RX only
22A	157.100	157.100	S	Canadian Coast Guard Liaison	Yes	Yes	CANADIAN CG	
23	157.150	161.750	D	Public Correspondence	No	Yes	TELEPHONE	
24	157.200	161.800	D	Public Correspondence	No	Yes	TELEPHONE	
25	157.250	161.850	D	Public Correspondence	No	Yes	TELEPHONE	
25B	---	161.850	S	Public Correspondence	-----	-----	TELEPHONE	RX only
26	157.300	161.900	D	Public Correspondence	No	Yes	TELEPHONE	
27	157.350	161.950	D	Public Correspondence	No	Yes	TELEPHONE	
28	157.400	162.000	D	Public Correspondence	No	Yes	TELEPHONE	
28B	---	162.000	S	Public Correspondence	-----	-----	TELEPHONE	RX only
60	156.025	160.625	D	Public Correspondence	No	Yes	TELEPHONE	
61A	156.075	156.075	S	U.S. Government, Canadian Coast Guard	Yes	Yes	UNAUTHORIZED	②

62A	156.125	156.125	S	Canadian Coast Guard	Yes	Yes	CANADIAN CG	
64	156.225	160.825	D	Public Correspondence, Duplex	No	Yes	TELEPHONE	
64A	156.225	156.225	S	U.S. Government, Canadian Commercial Fishing	Yes	Yes	UNAUTHORIZED	④
65A	156.275	156.275	S	Port Operations	Yes	Yes	PORT OPS	
66A	156.325	156.325	S	Port Operations	Yes	Yes	PORT OPS	① 1W only
67	156.375	156.375	S	Commercial, SAR	Yes	No	COMMERCIAL	
68	156.425	156.425	S	Boat Operations, Recreational	Yes	No	SHIP - SHIP	
69	156.475	156.475	S	Commercial Fishing Only	Yes	Yes	COMMERCIAL	
70	156.525	156.525	S	Digital Selective Calling - DSC	-----	-----	DSC	⑥
71	156.575	156.575	S	Boat Operations, Recreational	Yes	Yes	PLEASURE	
72	156.625	156.625	S	Inter-ship	Yes	No	SHIP - SHIP	
73	156.675	156.675	S	Commercial Fishing Only	Yes	Yes	COMMERCIAL	
74	156.725	156.725	S	Commercial Fishing Only	Yes	Yes	COMMERCIAL	
77	156.875	156.875	S	Port Operations	Yes	Yes	PORT OPS	① 1W only
78A	156.925	156.925	S	Boat Operations, Recreational	Yes	No	SHIP - SHIP	
79A	156.975	156.975	S	Commercial	Yes	Yes	COMMERCIAL	
80A	157.025	157.025	S	Commercial	Yes	Yes	COMMERCIAL	
81A	157.075	157.075	S	U.S. Government Operations	Yes	Yes	UNAUTHORIZED	④
82A	157.125	157.125	S	U.S. Government, Canadian Coast Guard	Yes	Yes	UNAUTHORIZED	④
83	157.175	161.775	D	Canadian Coast Guard	Yes	Yes	CANADIAN CG	
83A	157.175	157.175	S	U.S. Government, Canadian Coast Guard	Yes	Yes	UNAUTHORIZED	④
83B	---	161.775	S	Canadian Coast Guard, RX Only	-----	-----	CANADIAN CG	
84	157.225	161.825	D	Public Correspondence, Marine Operator	No	Yes	TELEPHONE	
85	157.275	161.875	D	Public Correspondence, Marine Operator	No	Yes	TELEPHONE	
86	157.325	161.925	D	Public Correspondence, Marine Operator	No	Yes	TELEPHONE	
87	157.375	157.375	S	Port Operations	No	Yes	PORT OPS	
88	157.425	157.425	S	Port Operations	No	Yes	PORT OPS	

Special Notes on Canada Channel Usage

- ①. LOW POWER (1 W) only.
- ②. Receive Only.
- ③. LOW POWER (1 W) initially. Override to HIGH POWER by holding down H/L key before transmitting. Used normally in bridge-to-bridge communications.
- ④. Lightly shaded simplex channels 21A, 23A, 61A, 64A, 81A, 82A, and 83A cannot be lawfully used in Canada waters unless special authorization is obtained from the Canadian Coast Guard. Not for use by the general public.

- ⑤ The letter "A" illuminated by the channel number indicates the Canada channel is simplex. This same channel is always duplex when selecting International. There is no "A" reference for International channels. The letter "B" is only used for some Canadian "Receive only" channels.
- ⑥ Channel 70 is designated for use exclusively for Digital Selective Calling (DSC), such as Distress, Safety, and Ship Calls. No voice communication is allowed on CH70. This channel is only available on DSC enabled radios.

Note: The CANADA mode is not legal to use in U.S. waters.

KEY: S = Simplex operating channel; D = Duplex operating channel.

C-4 WEATHER Channels

CH	RX (MHz)	TRAFFIC TYPE	NAME	REMARK
WX01	162.550	NOAA Weather Channel	NOAA WX	RX only
WX02	162.400	NOAA Weather Channel	NOAA WX	RX only
WX03	162.475	NOAA Weather Channel	NOAA WX	RX only
WX04	162.425	NOAA Weather Channel	NOAA WX	RX only
WX05	162.450	NOAA Weather Channel	NOAA WX	RX only
WX06	162.500	NOAA Weather Channel	NOAA WX	RX only
WX07	162.525	NOAA Weather Channel	NOAA WX	RX only
WX08	161.650	CANADIAN Weather Channel	CANADA WX	RX only
WX09	161.775	CANADIAN Weather Channel	CANADA WX	RX only
WX10	163.275	NOAA Weather Channel	NOAA WX	RX only

Appendix D - EU Inland Waterway Channels

Country Specific table

For specific channel information for your country, please refer to local authorities.

CH	SPECIFIC FOOT-NOTES	TRANSMITTING FREQUENCY (MHz)		SHIP-TO-SHIP	SHIP-TO PORT	NAUTICAL INFORMATION
		SHIP	LAND			
60	a)	156.025	160.625			x
01	a)	156.05	160.65			x
61	a)	156.075	160.675			x
02	a)	156.1	160.7			x
62	a)	156.125	160.725			x
03	a)	156.15	160.75			x
63	a)	156.175	160.775			x
04	a)	156.2	160.8			x
64	a)	156.225	160.825			x
05	a)	156.25	160.85			x
65	a)	156.275	160.875			x
06	a) b)	156.3	156.3	x		
66	a)	156.325	160.925			x
07	a)	156.35	160.95			x
67	a) c)	156.375	156.375			x
08	a) q)	156.4	156.4	x		
68	a)	156.425	156.425			x
09	a) b) c)	156.45	156.45			x
69	a)	156.475	156.475			x
10	e)	156.5	156.5	x		
70	a)	156.525	156.525	Digital selective calling for distress, safety and calling		
11		156.55	156.55		x	
71		156.575	156.575		x	
12		156.6	156.6		x	
72	a) r)	156.625	156.625	x		
13	f)	156.65	156.65	x		
73	f) g)	156.675	156.675			x
14	q)	156.7	156.7		x	
74	a)	156.725	156.725		x	
15	h)	156.75	156.75			x
75	o)	156.775	156.775		x	
16	i)	156.8	156.8			x

76	j) d) o)	156.825	156.825			x
17	h)	156.85	156.85			x
77	a) k)	156.875	156.875	x		
18		156.9	161.5			x
78		156.925	161.525			x
19		156.95	161.55			x
79	a)	156.975	161.575			x
20		157	161.6			x
80		157.025	161.625			x
21	a)	157.05	161.65			x
81	a)	157.075	161.675			x
22		157.1	161.7			x
82	l) m)	157.125	161.725			x
23	m)	157.15	161.75			x
83	a) m)	157.175	161.775			x
24	m)	157.2	161.8			x
84	m)	157.225	161.825			x
25	m)	157.25	161.85			x
85	a) m)	157.275	161.875			x
26	m)	157.3	161.9			x
86	a) m)	157.325	161.925			x
27	m)	157.35	161.95			x
87	a) d)	157.375	157.375			x
28	m)	157.4	162			x
88	a) p)	157.425	157.425			x
AIS 1	a) n)	161.975	161.975			
AIS 2	a) n)	162.025	162.025			

General remarks to Country Specific table:

- 1 The channels for service categories ship-to-ship and nautical information may also be used for vessel traffic -systems by traffic centres.
- 2 In some countries, frequencies certain channels are used for an other service category or other radio services. These countries are Austria, Bulgaria, Croatia, the Federal Republic of Yugoslavia, Hungary, Moldova, Romania, the Russian Federation, the Slovak Republic, the Czech Republic (with exemption of channels 08, 09, 72, 74 and 86), Ukraine and the Federal Republic of Yugoslavia. The Administrations concerned should make any possible attempt to make these frequencies channels as soon as possible available for the radiotelephone service on Inland Waterways and/or the required service category.

Explanation of specific footnotes in Country Specific table:

- a. In the countries mentioned under remark 2, it is strictly prohibited to use this channel.
- b. This channel is not allowed to be used between Rhine km 150 and km 350.
- c. In the Netherlands, this channel is used by its on-scene communications during safety operations on the North Sea, IJsselmeer, Waddenzee, Ooster- and Westerschelde.
- d. This channel may also be used for piloting, mooring, tugging and for other nautical purposes.
- e. This channel is the first ship-to-ship channel, unless the competent authority has designated an other channel. In the countries mentioned under remark 2, it is allowed that the output power is set to a value between 6 and 25 W until 1 January 2005.
- f. In the countries mentioned under remark 2, this channel is used for service category ship-to-port authorities.
- g. In the Netherlands, this channel is used by its national coastguard for communications during oil pollution operations on the North Sea and for safety messages for the North Sea, Waddenzee, IJsselmeer, Ooster- and Westerschelde.
- h. This channel may be used only for service category on-board on board communications.
- i. This channel may be used only for communications between seagoing vessels and participating land stations in case of distress and safety communications within the maritime sea-areas. In the countries mentioned under remark 2, this channel may be used only for distress, safety and calling.
- j. The output power shall be reduced automatically to a value between 0.5 and 1 W.
- k. This channel may be used for communications with a social character.
- l. In the Netherlands and Belgium, this channel may be used for transmitting messages concerning bunkering and victualling. The output power has to be reduced manually to a value between 0.5 and- 1 W.
- m. This channel may also be used for public correspondence.
- n. This channel will be used for an automatic ship identification and surveillance system (AIS) capable of providing worldwide operating on seas and Inland Waterways.
- o. The availability of this channel is on a voluntary basis. All existing equipment shall be capable to of operating on this channel within a ten-year period after the entry into force of this Arrangement.
- p. After permission of the competent authority, this channel may be used only for special events on a temporary basis.
- q. In the Czech Republic this channel is used for service category nautical information.
- r. In the Czech Republic this channel is used for service category ship-to-port authorities.

D-1 Special Channels ²

CH	SEND (MHz)	RECEIVE (MHz)	TRAFFIC TYPE	SHIP TO SHIP	SHIP TO SHORE	NAME TAG
00 ¹	156.000	156.000	UK Coast Guard Users	Yes	Yes	UK COAST GRD
M1	157.425	157.850	UK Marina Channel M1	Yes	Yes	UK MARINA
M2	161.425	161.425	UK Marina Channel M2	Yes	Yes	UK MARINA
31	157.550	162.150	INT'L, Duplex (Holland)	No	Yes	NL MARINA
96H	162.425	162.425	INT'L (Belgium)	No	Yes	BEL G MARINA
L1	155.500	155.500	INT'L (Skandinavia)	Yes	No	LEISURE 1
L2	155.525	155.525	INT'L (Skandinavia)	Yes	No	LEISURE 2
L3	155.650	155.650	INT'L (Skandinavia-- not in Denmark)	Yes	No	LE ISURE3
F1	155.625	155.625	INT'L (Skandinavia)	Yes	No	FISHING 1
F2	155.775	155.775	INT'L (Skandinavia)	Yes	No	FISHING 2
F3	155.825	155.825	INT'L (Skandinavia) call back	Yes	No	FISHING 3
AIS1	161.975	161.975	AIS1	-----	-----	-----
AIS2	162.025	162.025	AIS2	-----	-----	-----

Note:

1. Lightly Shaded Simplex channel CH00 is only available in the UK to Coast Guard users with written authorization.
2. The special channels above maybe fitted to your radio. These are only licensed for use in the country indicated. No attempt should be made to use them in any other country.

Appendix E - MMSI and License Information

E-1 Obtain Your User MMSI number



WARNING

A valid USER MMSI must be entered into this radio before these DSC functions can be used. You can't make any DSC transmissions until you've obtained a user MMSI and entered it into your Explorer 721 725.

You must obtain a user MMSI (Marine Mobile Service Identity) and enter it into your radio in order to use the DSC functions, including Track Buddy.

If you don't have a user MMSI, contact the appropriate authorities in your country.

If you're unsure who to contact, consult your Northstar dealer.

The user MMSI is a unique nine digit number, similar to a personal telephone number. It is used on marine transceivers that are capable of using DSC (Digital Select Calling).

E-2 Enter Your User MMSI



CAUTION *This is a once-only operation.*

1. Select DSC SETUP, then USER MMSI. A dashed line appears.

DSC SETUP

> USER MMSI
GROUP SETUP
INDIV REPLY

INPUT USER
MMSI

187654321

MMSI
> STORE
CANCEL

USER MMSI
INPUT AGAIN

2. Enter your user MMSI along the dashed line. Press ENT or push the rotary knob to confirm each correct entry and to move to the next digit.
If you make an error, press CH - until < appears, then press ENT or push the rotary knob to backup and correct the entry.
 3. Press ENT or push the rotary knob to store your user MMSI.
 4. Enter your user MMSI again as a password check, then press ENT or push the rotary knob to permanently store the user MMSI and return to the menu.
- You can view your stored user MMSI at anytime by selecting USER MMSI in the main menu.

E-3 License Information

Depending upon your location, you may need a radio station license for the VHF 721/725. You may also need an individual operator's license.

NAVICO HOLDING AS. recommends that you check the requirements of your national radio communications authorities before operating DSC functions.

Section 7 - Install the Explorer 721/725

7-1 Installation Options

There are two ways to install the radio. You can choose:

- **a deck or overhead mounted gimbal installation.** The reversible mounting gimbal is fixed to a suitable site and the radio is placed into it. The radio can be removed for storage and the viewing angle can be adjusted.
- **a recessed installation.** The radio is recessed into a cavity cut into a bulkhead. The radio fixture is permanent and the viewing angle cannot be adjusted.

NOTE: An optional handset with a 9.8' (3 m) docking cable included can be purchased and connected to your Explorer 721 base unit to give second station operation and intercom capability.

7-2 Location Requirements

Please check these BEFORE doing any cutting or drilling.

Whichever installation method you choose, ensure that the chosen location:

- is at least 3' (1 m) from the antenna
- allows easy connection to (at least) a 10 Amp fused 13.6 V DC electrical source and the antenna
- is at least 1.5' (45 cms) from the compass to avoid creating magnetic deviation of the compass during radio operation
- has a suitable space close by for installing the microphone bulkhead mount
- provides easy access to the controls on the front panel
- provides reasonable access to the wiring at the back of the radio
- provides enough room to fix the DSC warning label (721/725 US only).

The VHF721/725 has a large FSTN LCD screen with an optimum viewing angle of approx. ± 20 deg. Ensure the chosen location provides a suitable view of the display. Ideally, the user should be directly in front of the display or no more than ± 20 deg from the front of the display.

Note: If unsure, temporarily power up the radio and check for a suitable location.

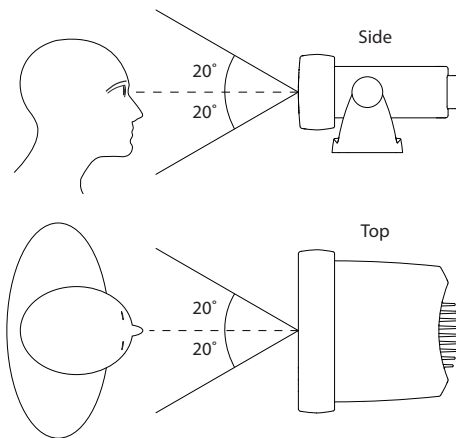

7-3 Checklist

The following items should be supplied in the box. Check before starting the installation and contact your dealer if an item is missing.

NOTE: An antenna is NOT provided. Consult your Northstar dealer for advice if necessary.

1. Mounting gimbal for the VHF radio
2. Power supply cable with in built 7 Amp fuse
3. External speaker connection cable with white (+) wire and black (-) wire
4. GPS connection cable
5. Two mounting knobs
6. Microphone bulkhead mount
7. Four self-tapping screws for the mounting gimbal
8. Four flat screws for the mounting gimbal
9. Four spring washers for the mounting gimbal
10. Four plain washers for the mounting gimbal
11. Four nuts for the mounting gimbal
12. Two self-tapping screws for the microphone bulkhead mount
13. Two flat screws for the microphone bulkhead mount
14. Two spring washers for the microphone bulkhead mount
15. Two plain washers for the microphone bulkhead mount
16. Two nuts for the microphone bulkhead mount
17. Two flush-mount brackets for recessed installation
18. Two M5x32 screws for recessed installation
19. Two M5x10 screws for recessed installation
20. Two plastic stoppers for the recessed installation (not pictured)
21. Installation template (not pictured)
22. One 7 Amp spare fuse (not pictured) in case of accidental reverse of battery polarity
23. Explorer 721/725 base unit and microphone (not pictured)
24. Explorer 721/725 protective cover (not pictured)

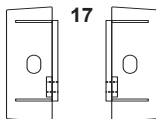
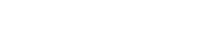
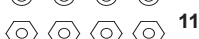
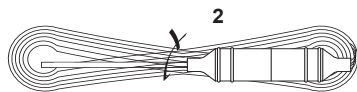
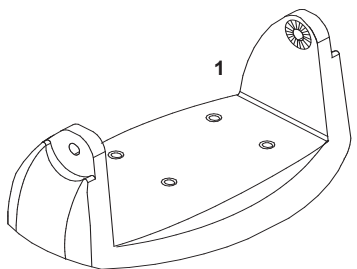

7-4 Gimbal Installation

1. Hold the mounting gimbal at the chosen location and use a soft pencil to mark the screw hole positions onto the mounting surface.
2. If you can't reach behind the mounting surface to attach the nuts, use the self-tapping screws instead of the flat screws shown in the picture. If you're drilling into fiberglass, use a drill bit smaller than 3/16" (5mm) to drill the pilot holes.
Otherwise, drill the four screw holes where marked, using a 3/16" (5mm) drill bit. Drill completely through the mounting surface.
3. Use a Phillips screwdriver and the set of four flat screws, spring washers, plain washers, and nuts to attach the mounting gimbal to the location site.
4. Slide the radio into the mounting gimbal.
5. Insert the two mounting knobs through the holes and tighten them sufficiently to hold the radio at the desired viewing angle.

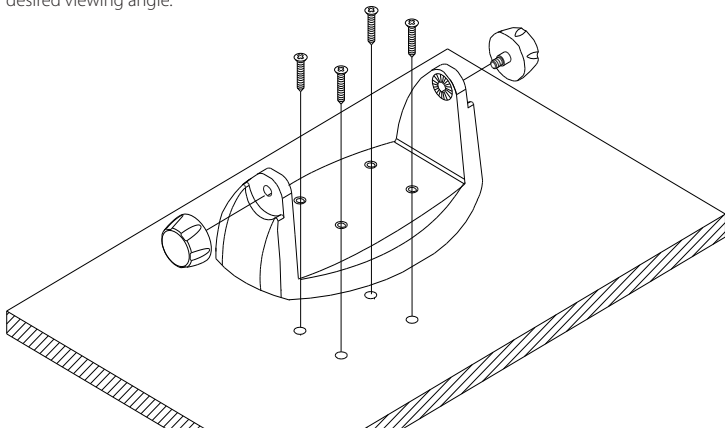

7-5 Change the Viewing Angle

The viewing angle on the gimbal mount has a 20° tilt range. To change the current viewing angle on the gimbal mount:

1. Support the radio, then cautiously loosen the mounting knobs until the radio can be moved.
2. Re-position the radio then tighten the mounting knobs again.

7-6 Recessed Installation

1. Tape the installation template onto the chosen location site.
2. Cut out the area marked by the solid dark line. (The dashed line indicates the total area that will be covered by the radio fascia after installation.)
3. Remove the installation template and slide the radio into the cavity.
4. Working from the rear of the bulkhead, align the ratched outstand on each side of the radio with the central hole in each mounting bracket.

- Use the two short M5x10 screws to screw the mounting brackets to the sides of the radio.
- Screw each M5x32 screw through the screw hole in the mounting bracket, then attach the stopper. If your bulkhead exceeds 0.51" (13mm), the stopper can be discarded if necessary.
- Tighten the M5x32 screws until the radio is held firmly against the rear of the bulkhead.

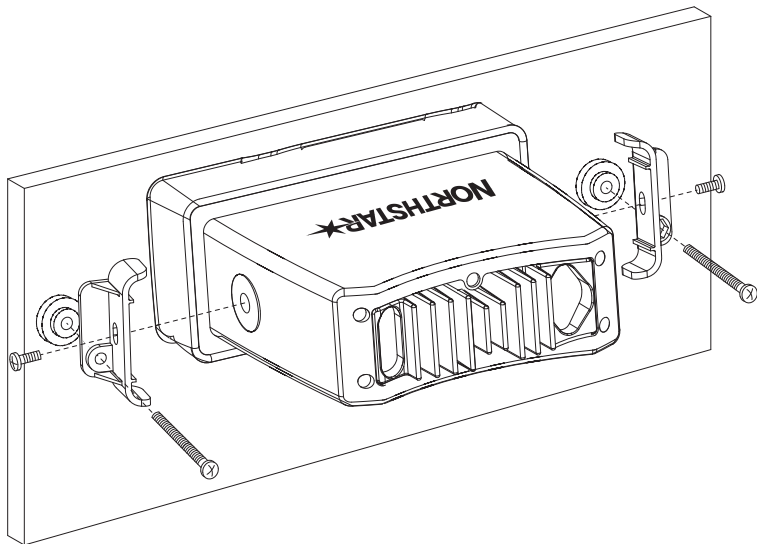

7-7 Install the Microphone Bulkhead Mount

- Hold the microphone bulkhead mount at the chosen location and use a soft pencil to mark the screw hole positions on the mounting surface.

Ensure that the microphone curly cable will comfortably reach this location BEFORE you drill.

- Drill the two pilot screw holes where marked.
- Use a short length Philips screwdriver and the set of two flat screws, spring washers, plain washers, and nuts to secure the microphone bulkhead mount at the location site.
- Hang the microphone on its mount.

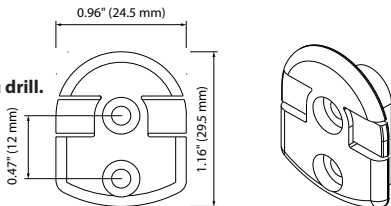

NOTE: (Explorer 721US/EU only) This mic clip has a special magnet glued in the rear of the clip to sense ON/OFF HOOK. All other mic hangers do not have magnets and therefore cannot be used.

7-8 Connect the Radio Cables

The connectors are on the rear of the base unit, as follows:

1. **GPS and COM connector.** For connection to GPS device via NMEA. Also includes NavBus wiring for Track Buddy and other features. See the following table for wiring and color codes. (If you're not using this, be sure to put the protective cap securely over the connector to protect it from moisture and dust.)
2. **Docking Cable connector (Explorer 721 US/EU only)** for optional Handset. Plug the docking cable jack into the connector. (If you're not using this, be sure to put the protective cap securely over the connector to protect it from moisture and dust.)
3. **External Speaker connector.** Plug the external speaker cable jack into the connector BEFORE powering on the radio. Use a 4 Ohm 4 Watt external speaker.
4. **RED Power wire.** Connect this to the POSITIVE (+) battery terminal. Check that a 10 Amp fuse is installed on this power cable close to the battery.
5. **BLACK Power wire.** Connect this to the NEGATIVE (-) battery terminal.
6. **ANT.** A radio antenna is not supplied. A suitable radio antenna must be mounted and connected before operating the Explorer 721/725 radio. Consult your dealer for advice if necessary.
7. **GND.** A ground connection is not usually required..

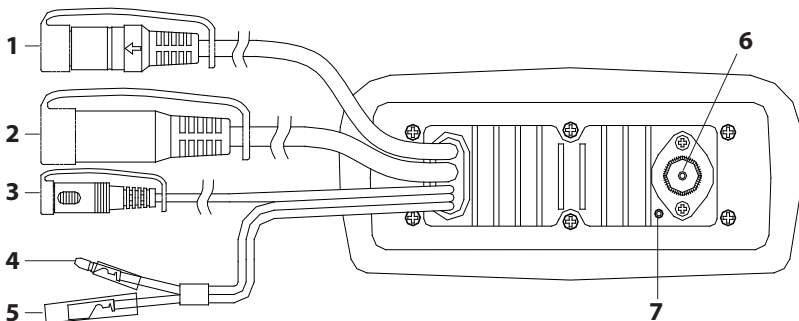

Wiring for GPS and COM connector (See 7-8, 1. GPS and COM connector)

Pin	Wire	Function	Notes
1	Red	No connection	(Not used)
2	Orange	NMEA OUT (+)	(To GPS)
3	White	Program/clone	(Not used)
4	Green	NMEA IN (-)	(From GPS)

Pin	Wire	Function	Notes
5	Yellow	NMEA IN (+)	(From GPS)
6	Black	NMEA OUT (-)	(Ground)
7	Blue	NAVBUS (+)	
8	Grey	NAVBUS (-)	

Connecting to a Northstar display using NavBus:

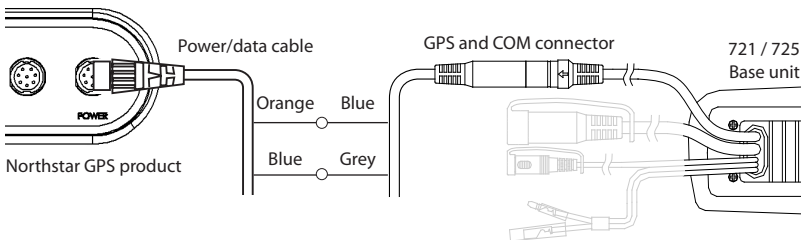

7-9 Set Up the Radio

IMPORTANT: You can't make any DSC transmissions until you've obtained a user MMSI and entered it into your Explorer 721/725 .

See Appendix E for Obtaining and Entering MMSI information.

7-11 The Completed Installation (with Optional 701 Handset)

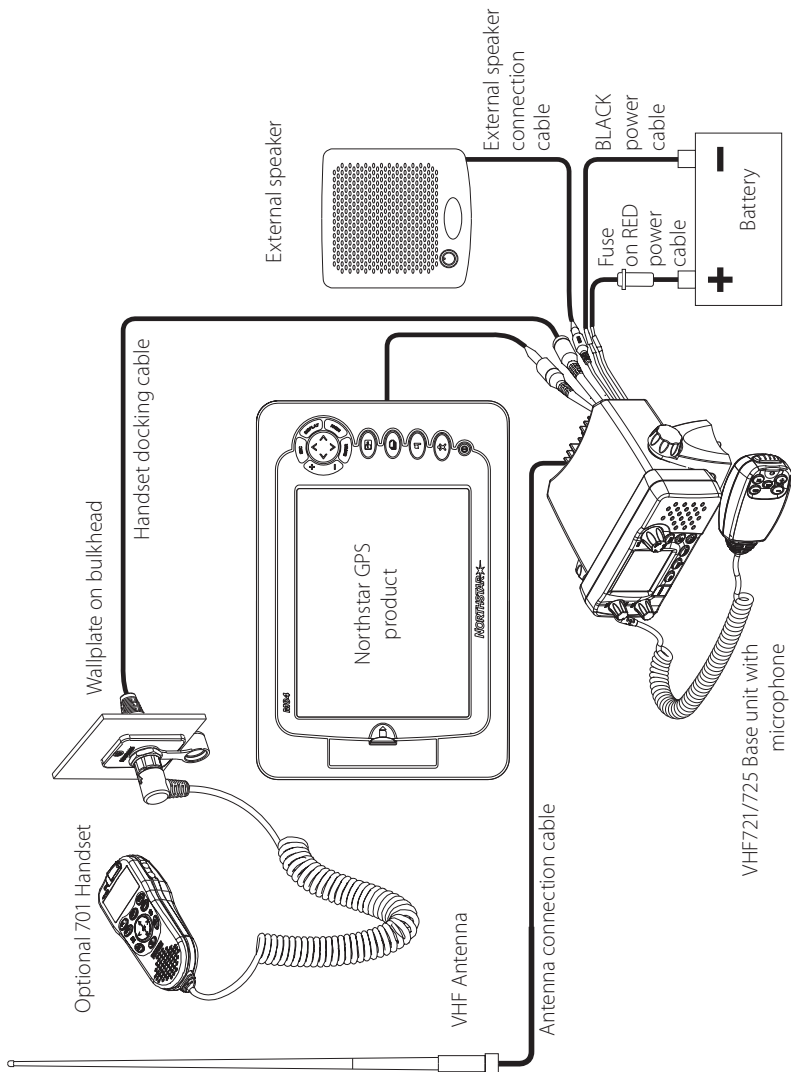

FOR FURTHER CONTACT DETAILS GO TO:

www.navico.com



NORTHSTAR 



Industry
Canada

Industrie
Canada



CE 0560  Explorer 721
CE 1177  Explorer 725