



NEC

NWA-039300-001
ISSUE 4.0

UNIVERGE SV8500

UNIVERGE SV7000

NEAX 2400 IPX
Internet Protocol eXchange

DT730/DT710/DT330/DT310

USER'S GUIDE

NEC Corporation
2010 August

LIABILITY DISCLAIMER

NEC Corporation reserves the right to change the specifications, functions, or features, at any time, without notice.

NEC Corporation has prepared this document for use by its employees and customers. The information contained herein is the property of NEC Corporation and shall not be reproduced without prior written approval from NEC Corporation. All brand names and product names on this document are trademarks or registered trademarks of their respective companies.

Copyright 2008-2010

NEC Corporation

TABLE OF CONTENTS

1. INTRODUCTION

FACE LAYOUT	1
KEYS AND PARTS.....	8
MENU KEY	14
SIMPLE OPERATION BY MENU KEY AND CURSOR KEY.....	16
ICON DISPLAY.....	16
SHORTCUT MENU	17
PROGRAMMABLE FEATURE KEYS.....	19
SOFT KEYS.....	21
CONDITIONS FOR DT700 SERIES.....	25

2. INSTALLATION PROCEDURE

ADJUSTING ANGLE OF TILT LEG.....	27
TO REMOVE TILT LEG.....	28
TO ATTACH TILT LEG.....	28
CONNECTING LAN CABLE.....	29
CONNECTING LINE CORD.....	30
INSTALLING DIRECTORY CARD.....	31
ATTACHING HANDSET.....	31
INSTALLING/REMOVING KEY SET UNIT	32
WALL MOUNTING	33

3. TERMINAL SETUP

SETUP WITH UP/DOWN KEY.....	37
SETUP WITH FEATURE KEY.....	38
SETUP WITH MENU KEY FOR DT700 SERIES	42
SETUP WITH MENU KEY FOR DT300 SERIES	91

TABLE OF CONTENTS

4. BASIC OPERATION

TO LOGIN	96
TO LOGOUT	96
TO MAKE AN EXTERNAL CALL	97
TO MAKE AN INTERNAL CALL	99
TO ANSWER AN EXTERNAL CALL	101
TO ANSWER AN INTERNAL CALL	103
MULTILINE APPEARANCE	104
TO HOLD A CALL	104
TO PLACE A CALL ON EXCLUSIVE HOLD	105
TO TRANSFER A CALL	105
HOW TO INPUT CHARACTERS	107
SECURITY MODE	121
EMERGENCY CALL	123

5. FEATURE OPERATION

TO ORIGINATE A CALL USING SELECTIVE DIALING (DYNAMIC DIAL PAD, PRESET DIAL)	125
TO ORIGINATE A CALL USING SPEED CALLING (ONE-TOUCH SPEED CALLING KEYS).....	126
TO REGISTER NAME ON ONE-TOUCH SPEED CALLING KEY	129
TO ORIGINATE A CALL USING SPEED CALLING - STATION/GROUP	129
TO ORIGINATE A CALL USING SPEED CALLING - SYSTEM.....	129
ACCOUNT CODE	131
FORCED ACCOUNT CODE	131
AUTHORIZATION CODE	131
VOICE CALL	132

TABLE OF CONTENTS

TO ANSWER A VOICE CALL HANDS FREE	133
AUTOMATIC INTERCOM.....	133
MANUAL INTERCOM.....	134
DIAL INTERCOM	135
CONFERENCE	136
TO ESTABLISH A BROKER CALL.....	136
TO ANSWER A CAMPED-ON CALL.....	136
CALL WAITING - ORIGINATING.....	137
CALL PARK	139
CALL PICK-UP (GROUP).....	140
CALL PICK-UP (DIRECT).....	140
OUTGOING TRUNK QUEUING	141
OFF-HOOK TRUNK QUEUING.....	141
EXECUTIVE OVERRIDE.....	141
LAST NUMBER REDIAL	142
CALL FORWARDING - ALL CALLS.....	142
CALL FORWARDING - BUSY LINE.....	144
CALL FORWARDING - DON'T ANSWER.....	145
LOGGED OUT IP STATION - CALL DESTINATION	146
CALL BACK	148
TO SAVE AND REPEAT A NUMBER	148
TO LEAVE A MESSAGE	150
TO ANSWER A MESSAGE	150
VOICE MAIL SYSTEM.....	151
MEET-ME PAGING	151
PAGING TRANSFER.....	152
BOSS/SECRETARY TRANSFER.....	154
BOSS/SECRETARY - MW LAMP CONTROL	154
BOSS SECRETARY OVERRIDE	155

TABLE OF CONTENTS

DO NOT DISTURB	156
CALL REDIRECT	157
PRIVACY	158
PRIVACY RELEASE.....	159
PHONEBOOK	160
CALL HISTORY	170

6.DIRECTORY OPERATION

TO ADD NEW DATA	175
TO CHANGE GROUP NAME	182
TO FIND A REGISTERED DATA	184
TO MAKE A CALL FROM DIRECTORY.....	198
TO ADD PREFIX TO NUMBER	199
TO EDIT DIRECTORY DATA	201
TO DELETE ALL DATA	202
TO DELETE A SPECIFIC DATA	203

7.CALL HISTORY OPERATION

FOR DT730 SERIES	
TO VIEW CALL HISTORY	206
TO MAKE A CALL FROM CALL HISTORY	208
TO ADD CALL HISTORY DATA TO DIRECTORY	209
TO EDIT DIRECTORY DATA FROM CALL HISTORY	212
TO DELETE ALL DATA	215
TO DELETE A SPECIFIC DATA	216
FOR DT330 SERIES	
TO VIEW CALL HISTORY	218
TO MAKE A CALL FROM CALL HISTORY	221

TABLE OF CONTENTS

TO DELETE ALL DATA	222
TO DELETE A SPECIFIC DATA	223

8.SPECIFICATIONS

TECHNICAL SPECIFICATIONS.....	225
-------------------------------	-----

9.MENU LIST

MENU LIST FOR DT730 SERIES	227
MENU LIST FOR DT710 Series	234
MENU LIST FOR DT330 Series	237

10.WEB PROGRAMMING

OUTLINE	239
TO LOGIN.....	240
TO LOGOUT	242
HOW TO OPERATE	244

This page is for your notes.

1. INTRODUCTION

FACE LAYOUT

ITL-8LD-1 (DT730 Series)

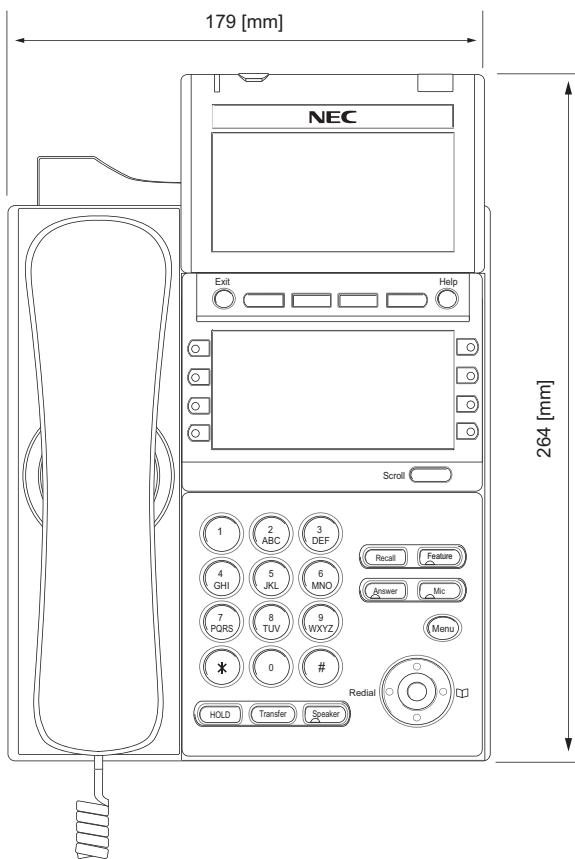

DTL-8LD-1 (DT330 Series)

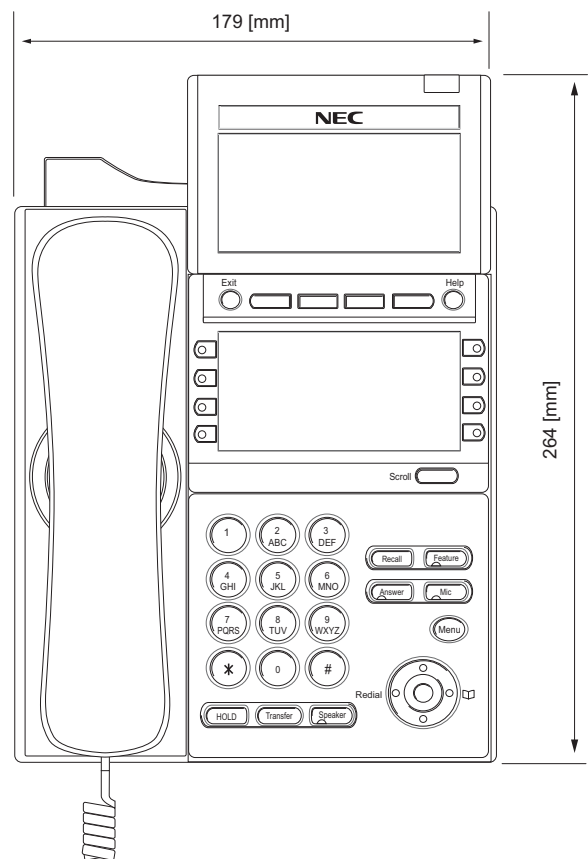

ITL-32D-1 (DT730 Series)

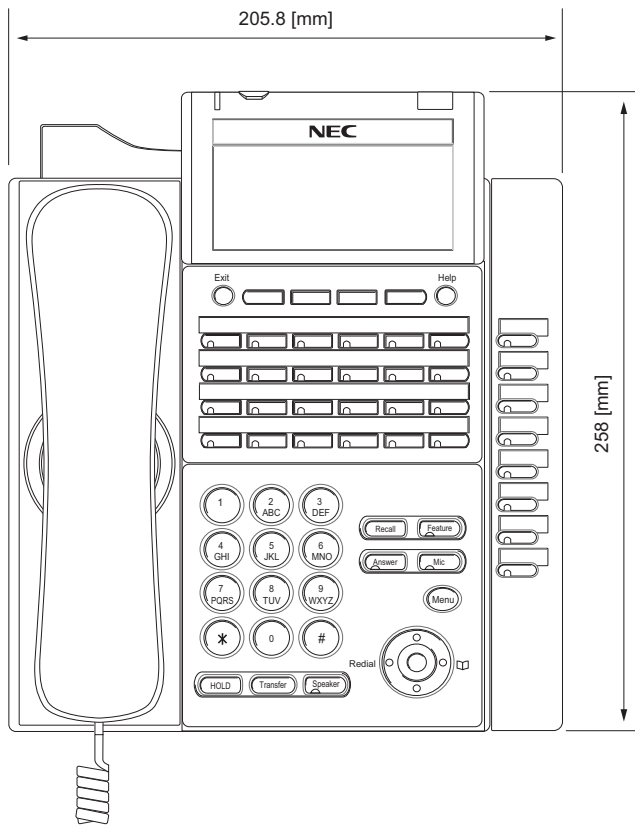

DTL-32D-1 (DT330 Series)

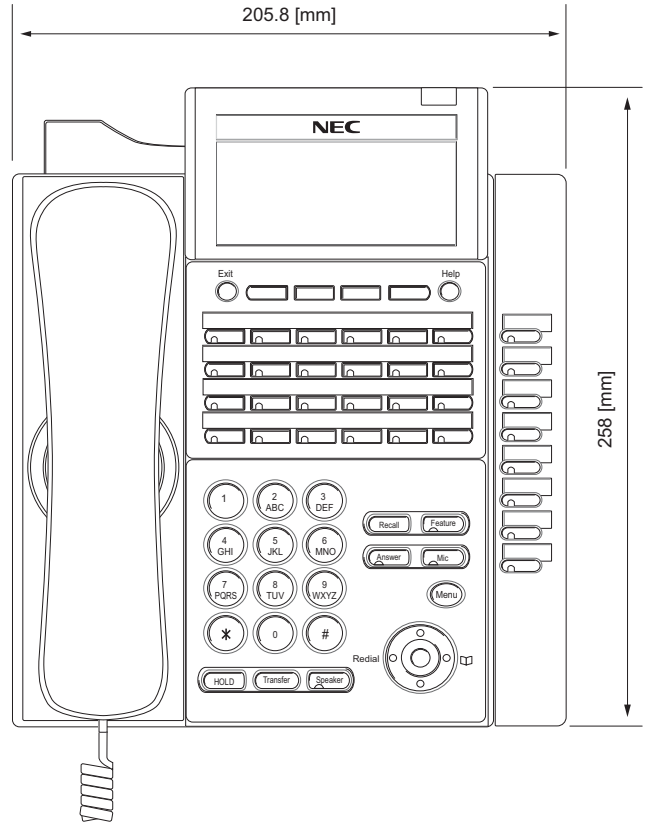

ITL-24D-1 (DT730 Series)

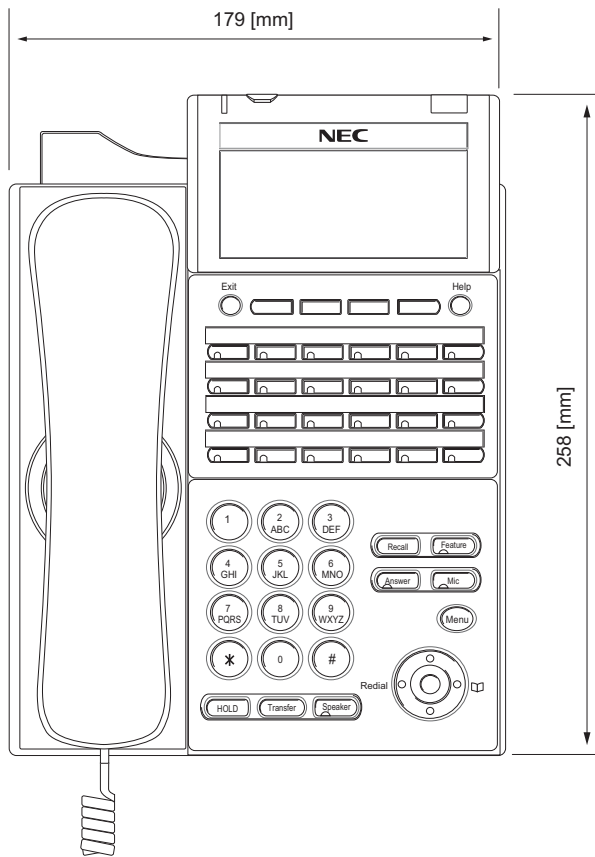

DTL-24D-1 (DT330 Series)

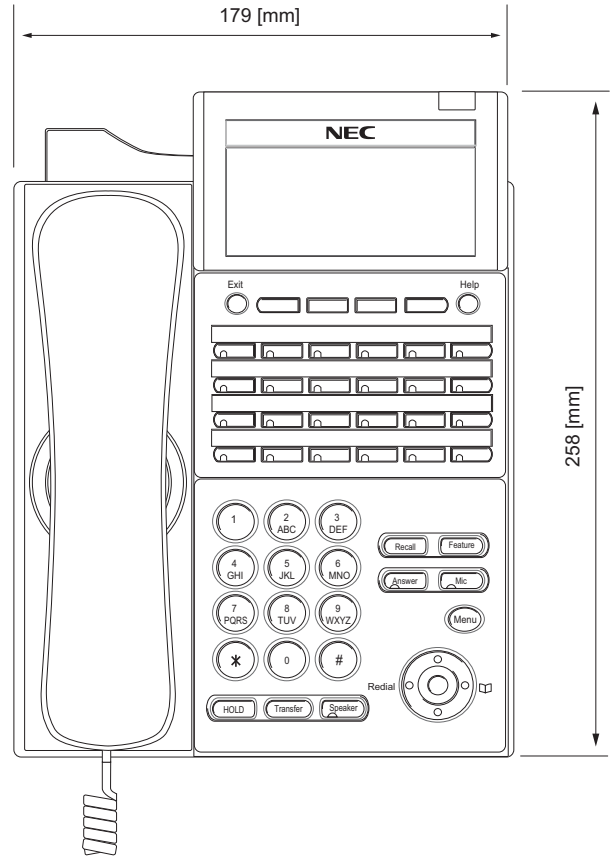

ITL-12D-1 (DT730 Series)

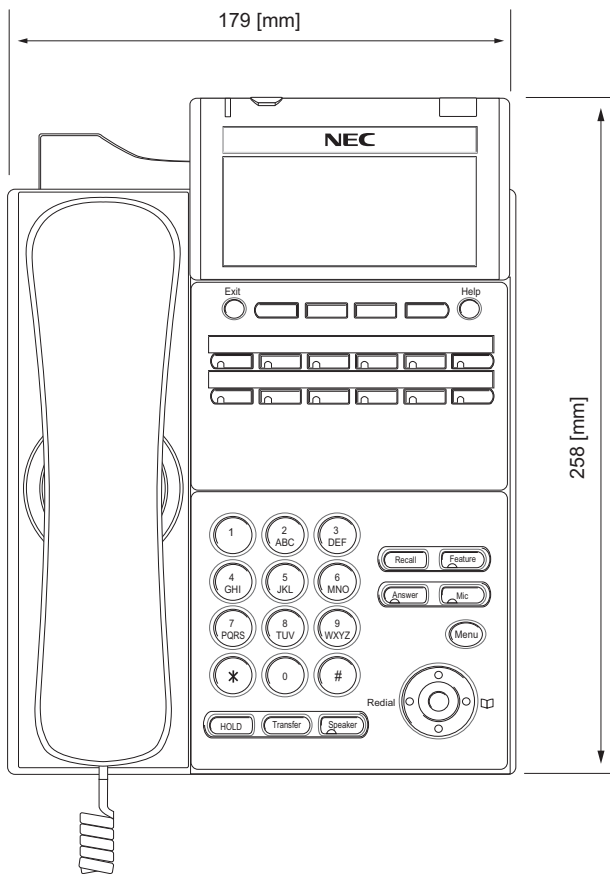

DTL-12D-1 (DT330 Series)

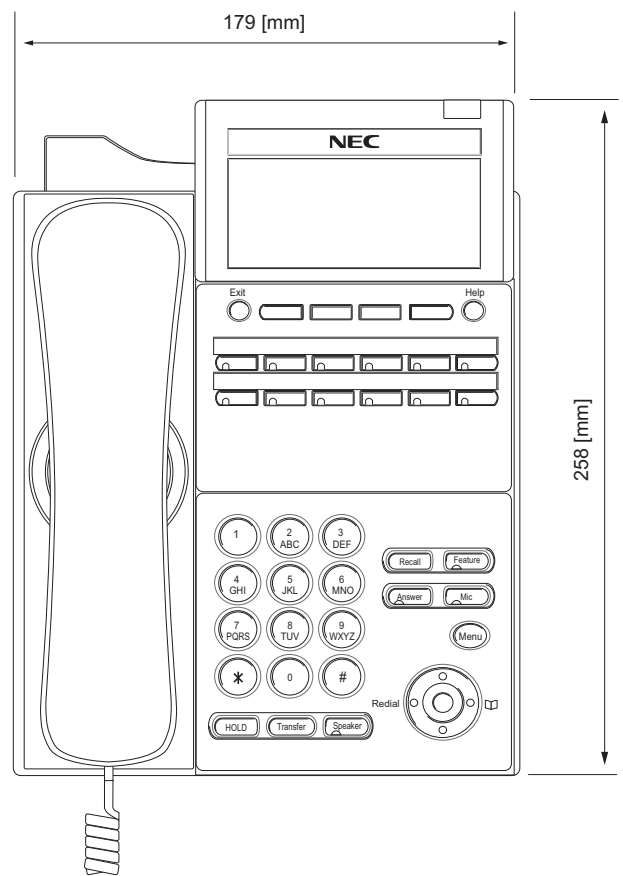

ITL-12PA-1 (DT730 Series)

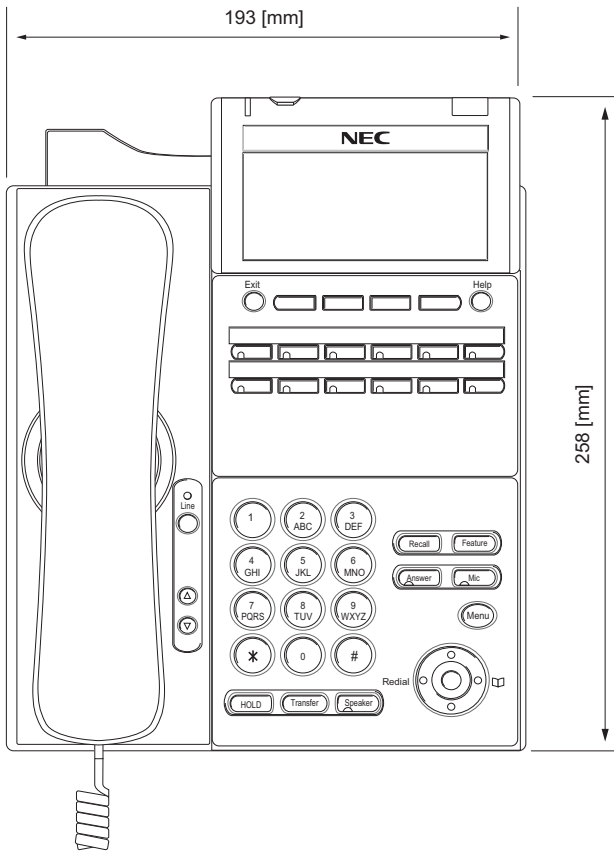

DTL-12PA-1 (DT330 Series)

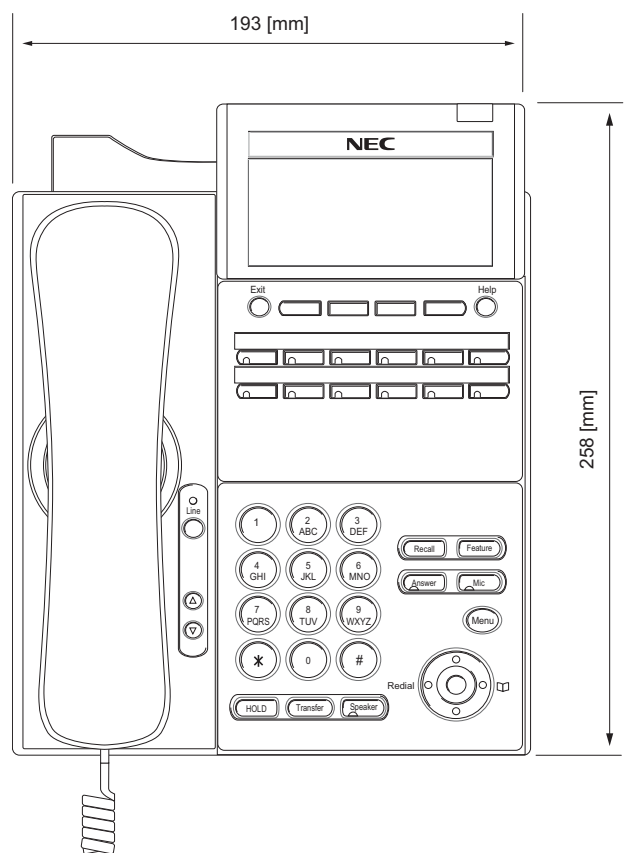

ITL-6DE-1 (DT710 Series)

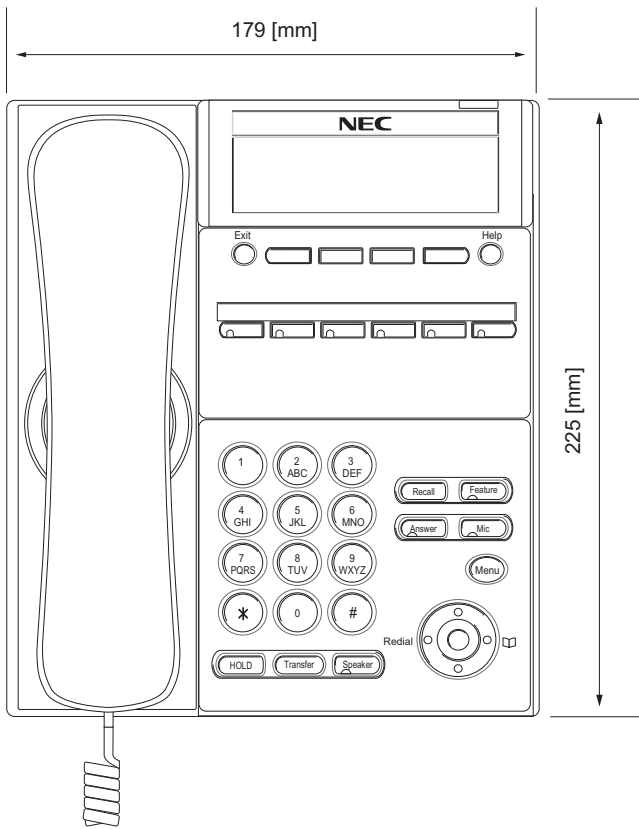

DTL-6DE-1 (DT310 Series)

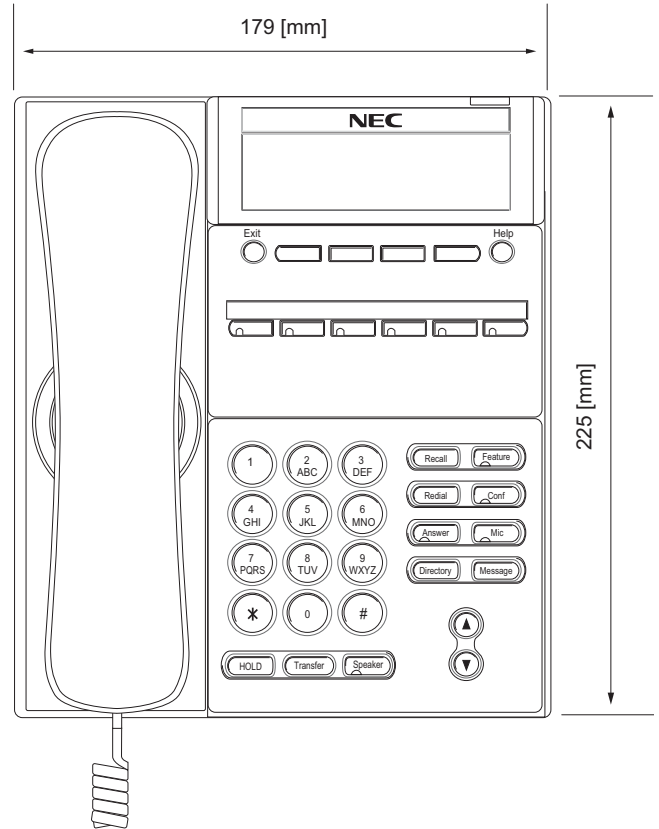

ITL-2E-1 (DT710 Series)

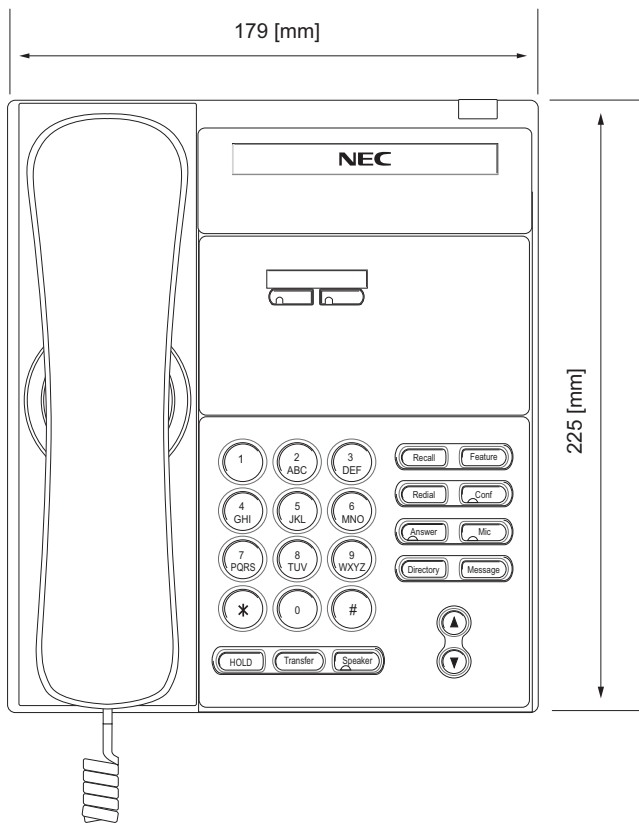

DTL-2E-1 (DT310 Series)

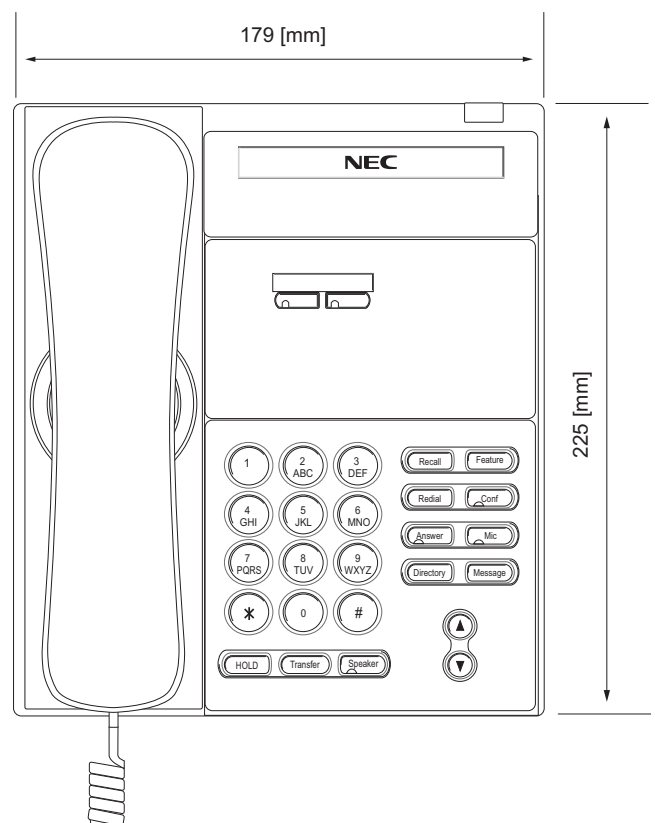

KEYS AND PARTS

• KEYS AND PARTS ON ITL-24D-1

This subsection explains keys and parts of DT Series taking ITL-24D-1 as an example.

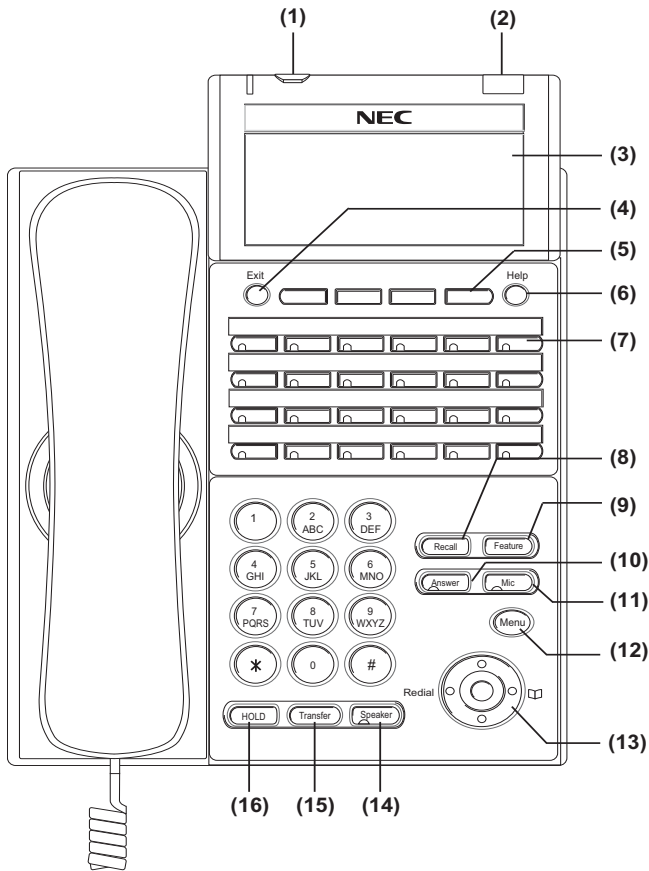

(1) Security Button (DT730 only)

You can prevent information leakage from terminal by simple operation.

(2) Call Indicator Lamp

Lamp at the top corner of DT Series Display flashes when a call terminates to the terminal. Also, when using Voice Mail service, the Lamp lights steadily when a message has been left.

(3) LCD

LCD (Liquid Crystal Display) provides DT Series activity information plus date, time and Soft Key Operation.

(4) Exit

To exit Menu or Help mode and go back to the time display.

(5) Soft Keys

Any feature shown at the bottom of the LCD is available. The appropriate feature key is displayed on the screen according to the call handling process.

(6) Help

Explanations of the Soft Keys can be called up on the LCD by pressing this key.

(7) Programmable Keys

These keys can be programmed as Flexible Line key/Programmable Feature Key by Telephony Server Administrator. When Telephony Server Administrator sets "One-Touch Speed Dial key" on the programmable keys, you can assign any numbers (ex. Telephone num-

ber, etc.) to the key (up to 32 digits).

* For the assignment of the keys, contact your Telephony Server Administrator.

** When two telephone numbers are assigned on A side and B side of “One-Touch Speed Dial key”, you can switch the side by **PAGE** key (Soft key).

(8) Recall

Press key to finish the call and hear the dial tone.

(9) Feature

Used to activate any features as terminal setup functions, etc. and to program One-Touch Speed Dial Keys.

(10) Answer

When LED on this key is lit, press key to answer a waiting call.

(11) Mic

Press key to respond hands free. LED on this key lights during speakerphone operation.

(12) Menu

To access the local menu of DT750, such as Call History, Directory or Terminal Setting.

(13) Cursor

By using this key, DT Series user can access to various features with simple operation.

Details on Cursor key

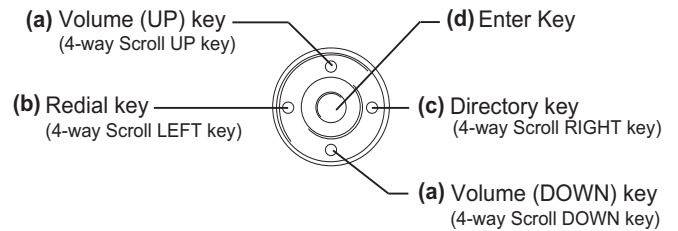

(a) Up/Down

(∨ DOWN ^ UP)

Used to adjust LCD contrast, speaker/receiver volume, and ringer volume.

- LCD Contrast:
Press (∨) or (^) key while idle.
- Speaker/Receiver Volume:
Press (∨) or (^) key during conversation.
- Ringer Volume:
Press (∨) or (^) key during ringing.

(b) Redial

(Last Number Call, Speed Calling-Station/Group)

Press key to activate redial feature. Press redial and scroll back through numbers that have been dialed. When the desired number is displayed, press the ✕ or # key to activate dialing.

Note: A-law Countries [Europe, Australia, Russia, Latin America, Middle near East, other Asian nations]: #
μ-law Countries [North America, Japan, Hong Kong, Taiwan]: ✕





(c) Directory

Pressing this key opens Directory menu. For details on Directory service, see [6.DIRECTORY OPERATION](#).

(d) Enter

DT330/DT730 Series has shortcut menu for frequently-used features. Use this key to display the shortcut menu (see [SHORTCUT MENU](#)) and determine the selected item in the menu.

Also, this key is used as cursor-movement key on the Menu screen.

	Up	Move the highlighted area one line up the screen.
	Down	Move the highlighted area one line down the screen.
	Left	Go back to the previous screen.
	Right	Go to the screen which corresponds to the highlighted menu item.
	Enter	Go to the screen which corresponds to the highlighted menu item.

(14)Speaker

Controls the built-in speaker which can be used for Hands Free dialing/monitoring.

LED on key lights when key is active.

* DT730/DT330 support for full duplex hands-free mode. DT710/DT310 are half duplex hands-free mode.

(15)Transfer

Allows the station user to transfer established calls to another station, without attendant assistance.

(16)Hold

Press this key to place an internal or external call on hold.

• THE OTHER KEYS AND PARTS

Redial (only for DTL-2E-1, ITL-2E-1 and DTL-6DE-1)

(Last Number Call, Speed Calling-Station/Group)
Press key to activate redial feature. Press redial and scroll back through numbers that have been dialed.

When the desired number is displayed, press the * or # key to activate dialing.

Note: A-law Countries [Europe, Australia, Russia, Latin America, Middle near East, other Asian nations]: #
μ-law Countries [North America, Japan, Hong Kong, Taiwan]: *

Conf (only for DTL-2E-1, ITL-2E-1 and DTL-6DE-1)

Press key to establish a conversation. LED on key lights when key is active.

Directory (only for DTL-2E-1, ITL-2E-1 and DTL-6DE-1)

Press key to activate speed calling - system feature.

Message (only for DTL-2E-1, ITL-2E-1 and DTL-6DE-1)

Press key to access the voice mail system.

Up/Down (only for DTL-2E-1, ITL-2E-1 and DTL-6DE-1)

(∇ DOWN ^ UP)

Used to adjust LCD contrast, speaker/receiver volume, and ringer volume.

- LCD Contrast:
Press (∇) or (^) key while idle.
- Speaker/Receiver Volume:
Press (∇) or (^) key during conversation.
- Ringer Volume:
Press (∇) or (^) key during ringing.

8LD Display (only for DTL-8LD-1/ITL-8LD-1)

32 (8 keys x 4 pages) additional programmable keys (Flexible Line/Programmable Feature key) are provided. Also, information set to each programmable key is displayed on 8LD display. For setting of the programmable key, contact Telephony Server Administrator.

When Telephony Server Administrator sets “One-Touch Speed Dial key” on the programmable keys, you can assign any numbers (ex. Telephone number, etc.) to the key (see [TO ORIGINATE A CALL USING SPEED CALLING \(ONE-TOUCH SPEED CALLING KEYS\)](#) and [TO REGISTER NAME ON ONE-TOUCH SPEED CALLING KEY](#)).

* For the assignment of the keys, confirm to the Telephony Server Administrator.

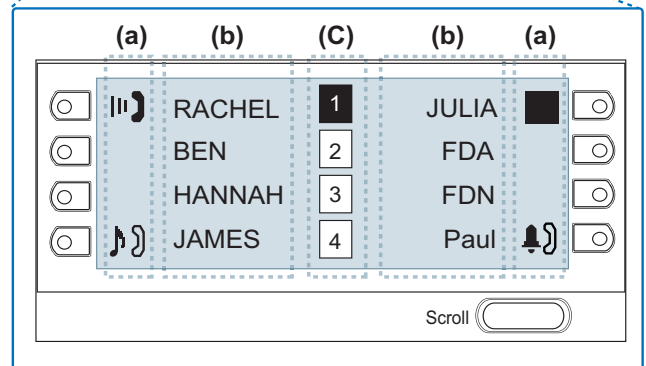
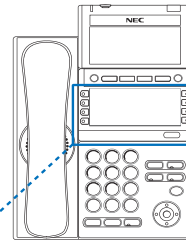

(a) Icon

Status information on the Line key such as Call termination, Call Hold or Busy can be indicated as following Icons.

User Status	Icon	Flashing Pattern
• Idle	No Icon	-

User Status	Icon	Flashing Pattern
• Call Hold (Individual Hold/Individual Hold on Call Park Group)		Blink
• Call Hold (Other Party Hold/Other Party Hold on Call Park Group)		
• Recall (Individual Hold/Exclusive Call Hold/Call Transfer/Individual Hold on Call Park Group)		
• Receiving an Incoming Call		
• During Conversation (Individual Use) • Call Transfer • Conference		Steady Lit
• During Conversation (Other Party Use) • Active Feature (Under a setting of feature key like a "Call Forwarding")		

(b) Programmable Key Information

Programmable Key Information displays the followings.

Key	Description	Maximum digits to be displayed
Line Key	- Name and Number information	8 digits.
One-Touch Speed Dial Key	- Speed Dial Name Information - Number Information	8 digits.
Feature Key	- Feature Name	6 digits.

(c) Page Icon

8LD display has four pages (8 programmable keys per page). Page Icon key indicates currently displayed page. You can switch the programmable key display from page 1 to 4 by using **Scroll** key.

1	Programmable Key 1-8	Black background indicates currently displayed page.
2	Programmable Key 9-16	
3	Programmable Key 17-24	Flashing indicates page with event happening.
4	Programmable Key 25-32	

Note: The icon flashes during events such as call termination to a line key or call back.

Example: Page Turning by Scroll Key

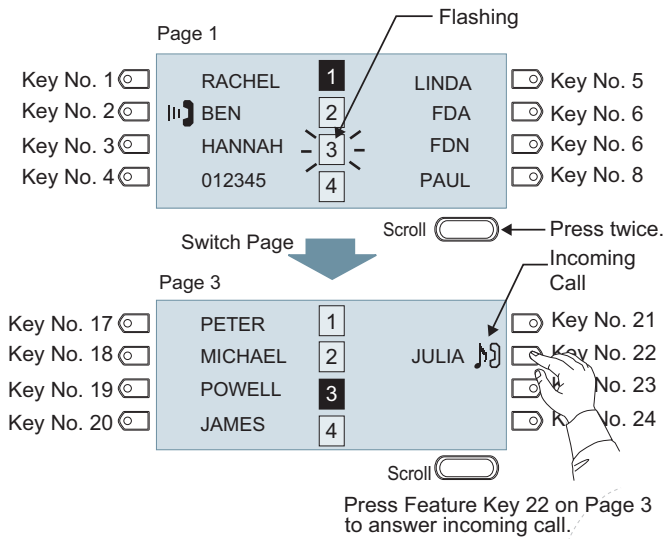

Note: For example, when an incoming call is terminated to a line key on Page 3 while Page 1 is being displayed on the screen, the screen is not automatically switched from Page 1 to page 3. You must display Page 3 manually and then answer the incoming call.

The following shows LCD indication of Programmable keys.

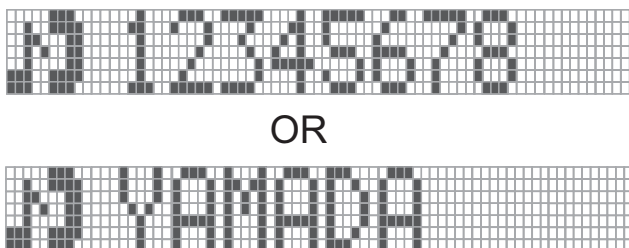

Appropriate icons are displayed according to the feature. These displays cannot be changed by user.

The following shows each LCD indication when One-Touch Speed Dial key is set to Programmable key.

When Station line/Trunk line are assigned.

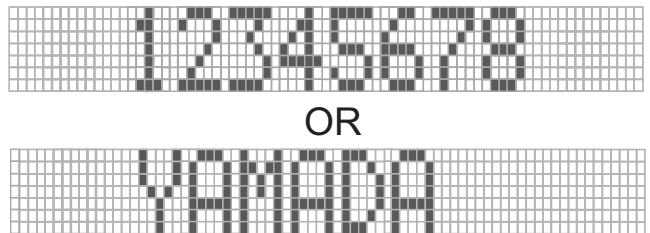

No icons are displayed.

* You can register name on each One-Touch Speed Dial key. For the procedures, see [TO REGISTER NAME ON ONE-TOUCH SPEED CALLING KEY](#).

When any features using feature access code are assigned.

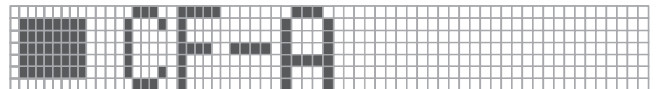

Icons turn black.

* You can register name on each One-Touch Speed Dial key. For the procedures, see [TO REGISTER NAME ON ONE-TOUCH SPEED CALLING KEY](#).

(3) Scroll Key

This key is used to turn over the page of 8LD display.

MENU KEY

From the **Menu** key, you can use various application features such as Directory and Call History.

To Display Menu List

STEP 1: Press **Menu** key while indicating the current time on LCD. The Menu List is displayed in LCD. Use Cursor Key to select desired Menu Item.

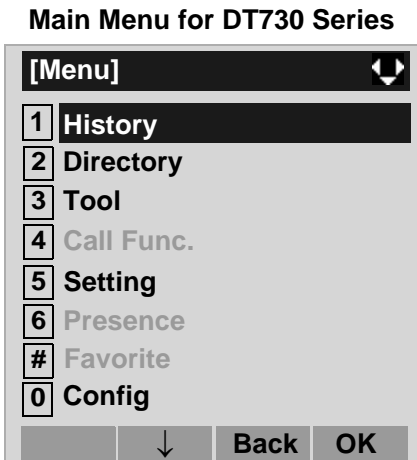

Menu Item	Description
1 History	To view Call History. There are two types of Call History features. On the one hand, the history data is stored in the server (system) memory. On the other hand, the history data is stored in the memory of the telephone (see 7.1 FOR DT730 SERIES in chapter 7 Call History Operation).
2 Directory	To use Directory features. There are the following three types of directory features. <ul style="list-style-type: none"> • Personal Directory: Controlled by telephone set. For details, see 6. DIRECTORY OPERATION. • Phonebook: Controlled by the system. For details, see PHONEBOOK in chapter 5. • Corporate Directory: Controlled by the external XML server. For details, please contact the system administrator.
3 Tool	- Uses when accessing external XML server. For details, please contact the system administrator. - Uses when sending/receiving Instant Message (Not used).
4 Call Func.	Currently Not Used (grayed out).
5 Setting	To control settings for ringing volume, LCD display, and Music on Hold. For details, see SETUP WITH MENU KEY FOR DT700 SERIES .
6 Presence	Currently Not Used (grayed out).
# Favorite	Currently Not Used (grayed out).
0 Config	This item is used for Configuration setting of DT Series. For details, please contact the system administrator.

Main Menu for DT710 Series

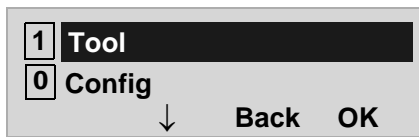

Note: DTL-6DE-1/ITL-2E-1/DTL-2E-1 does not have Menu key.

Note: Unavailable Menu items are grayed out.

Menu Item	Description
1 Tool	- Uses when accessing external XML server. <u>For details, please contact the system administrator.</u> - Uses when sending/receiving Instant Message (Not used).
0 Config	This item is used for Configuration setting of DT Series. <u>For details, please contact the system administrator.</u>

Main Menu for DT330 Series

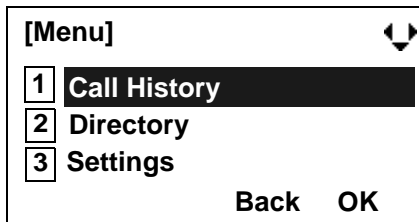

Menu Item	Description
1 Call History	To view Call History. For details, see 7.2FOR DT330 SERIES in chapter 7Call History Operation.
2 Directory	To use Phonebook function. For details, see PHONEBOOK in Chapter 5.
3 Setting	To control settings for ringing volume, LCD display, and Music on Hold. For details, see SETUP WITH MENU KEY FOR DT300 SERIES.

SIMPLE OPERATION BY MENU KEY AND CURSOR KEY

By using  key and  key, DT Series user can access Call History, Directory and terminal settings with simple operation.



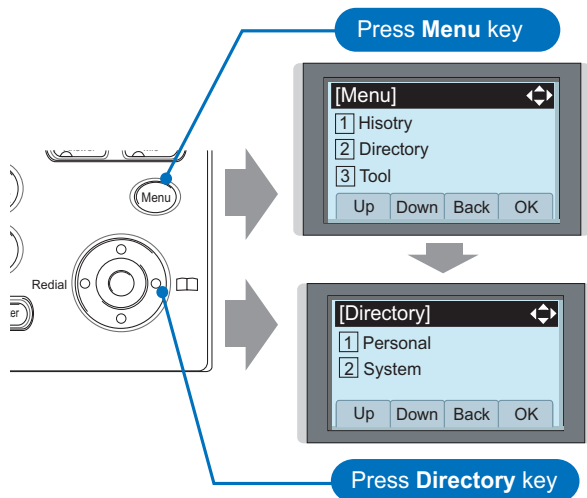

As an example, the following operations show how to access the Directory menu.

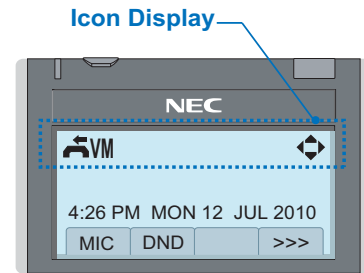

ICON DISPLAY

The LCD of DT730 Series/DT330 Series displays Desktop Icons which provide notification when events (such as missed call and voice mail) occur.



Feature	Icon	Description
Missed Call		This icon appears when there is a missed call. Once you have checked the missed call, this icon will disappear.
Voice Mail		This icon provides notification of incoming Voice Mail. Once you have checked the mail, this icon will disappear.
Cursor		This icon indicates the currently available direction of the Cursor key.
Encryption		This icon appears when the conversation is encrypted.

SHORTCUT MENU

As shown in the figure below, DT730 Series/DT330 Series has Shortcut Menu for frequently-used features. You can access to Shortcut Menu by pressing (Enter) key.

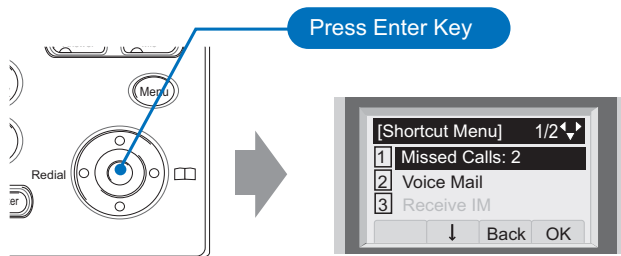

Note: DT710 Series/DT310 Series do not support the Shortcut Menu.

Shortcut Menu includes the following features.

Note: Unavailable Menu items are grayed out.

Shortcut Menu for DT730 Series

Feature	Description
1 Missed Calls	Access history of Missed Calls.
2 Voice Mail	Access history of incoming Voice Mail.
3 IM	Currently Not Used (grayed out).
4 Presence	Currently Not Used (grayed out).
5 Bluetooth	Currently Not Used (grayed out).

Shortcut Menu for DT330 Series

Feature	Description
1 Missed Calls	Access to history of Missed Call.
2 Voice Mail	Access to history of incoming Voice Mail.

As an example of DT730 Series, the following shows how to view the log data of missed call from the Shortcut menu.

STEP 1: Press (Enter) key. The Shortcut menu screen is displayed on LCD.

STEP 2: Select 1 Missed Calls and then press (Enter), (Right-cursor) or OK soft key.

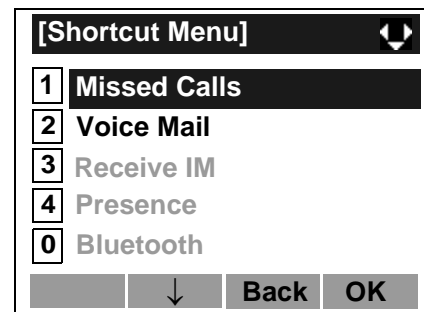

STEP 3: The log data of the last call is displayed.

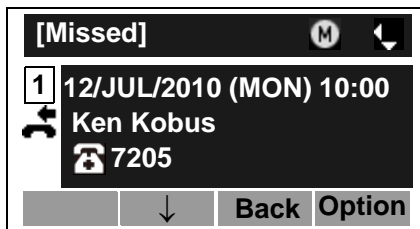

Note: If two or more records exist, use  or \uparrow/\downarrow soft key to display the next/former records.

Note: For unanswered incoming calls,  will be displayed on the left of the name.

Note: If you make/answer a call to/from the telephone number which is registered to Personal Directory, the corresponding name will be displayed as call history data.

STEP 4: Press  (Enter) key while displaying the log data for the target telephone number on LCD.

Note: While the log data is displayed, you cannot make a call by dialing a telephone number.

PROGRAMMABLE FEATURE KEYS

These are examples of DT Series features available by pressing the programmable keys. Some features using feature access code may be programmed by the user. Others must be programmed by the telephone system administrator.

AICM:

Press key to activate "Automatic Intercom".

DICM:

Press key to activate "Dial Intercom".

DND (Do Not Disturb):

Press key to activate or cancel "Privacy" feature.

FDA:

Press key to activate or cancel "Call Forwarding – All Calls" feature.

FDB:

Press key to activate, verify, or cancel "Call Forwarding – Busy Line" feature.

FDN:

Press key to activate, verify, or cancel "Call Forwarding – Don't Answer" feature.

MICM:

Press key to activate "Manual Intercom".

MSG (Message):

Press key to leave message indication at station in no answer or busy condition.

MULTILINE APPEARANCE:

A programmable extra extension key. Press this key to see status of extra extension.

MW-SET:

Press key to leave message waiting indication on boss' station from secretary's station.

MW-OFF:

Press key to cancel message waiting indication on boss' station from secretary's station.

P-RLS:

Press key to release "Privacy" feature.

S&R (Save and Repeat):

Press key to store a number or redial a stored number.

SIG:

Press key to cause chime at predetermined station.

NAME:

Press key to register name for the key to **One-Touch Speed Calling** key.

RVERS:

Press key to reverse the black and white in its display: background, characters and icons.

LED

Programmable Feature keys have a built-in Light Emitting Diode (LED) that lights or flashes according to the activity of that Feature key.

Function Key Activities

Feature + 0 = Side Tone On/Off. (for handset)*
Feature + 1 = Turns microphone on or off.
Feature + 2 = Adjusts handset receiver volume.*
Feature + 3 = Selects ringer tone.*
Feature + 4 = Adjusts transmission/receiving volume.*
Feature + 5 = Activates hands-free operation.*
Feature + 6 = Deactivates hands-free operation.*
Feature + 7 = Turns call indicator lamp on or off for incoming call notification. (If turned off, this lamp will still light to indicate message waiting.)
Feature + 8 = Selects between Normal, Dynamic Dial Pad, and Preset Dial.

Note: * indicates the services which are not available for DT700 Series.

SOFT KEYS

The Soft Keys on the DT Series provide a set of functions on the LCD that adapt to the changing state of the telephone. While default Soft Key settings are provided, desired functions can be assigned to individual stations as required. The Soft Keys, at the bottom of the LCD, can display the names of available functions, names of user-assigned functions and names of functions assigned by a specific Soft Key pattern. Displayed Soft Keys can vary, depending on the state of the phone and/or when the Next/Previous key is pressed.

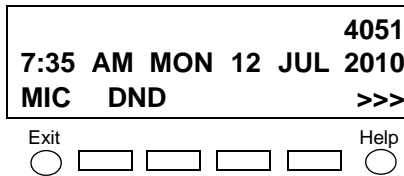

Note: Soft Key function is available for the terminals with LCD.

Exit Key

Press to exit Menu or Help mode and go back to the time display.

Help Key

Press the Help Key, then desired Soft Key for helpful information about that key.

MIC (Microphone)

Press the Soft Key below "MIC" to activate or deactivate the Microphone. LED on MIC key will illuminate when MIC is on.

DND (Do Not Disturb)

Press the Soft Key to reject call termination to the

preassigned station.

Default Displays for Each Status

Default Soft Key settings are provided corresponding to particular functions. Different Soft Key settings are displayed at the bottom of the LCD depending on the status, as shown below.

Different patterns of Soft Key settings can be registered for individual call status and assigned to individual terminals as required.

IDLE

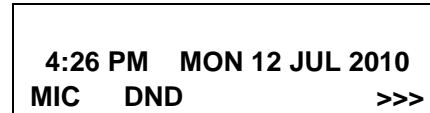

DIAL TONE/DIALING



Push >>>



RINGING

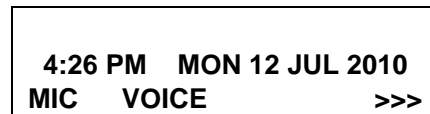

BUSY

(1)

BUSY	2000
4:26 PM MON 12 JUL 2010	
MIC CB CW >>>	

Push >>>

(2)

BUSY	2000
4:26 PM MON 12 JUL 2010	
S&R	>>>

CONNECTION

	2000
4:26 PM MON 12 JUL 2010	
MIC DND	>>>

CONSULTATION HOLD

TRANSFER	2000
4:26 PM MON 12 JUL 2010	
MIC CONF	>>>

Soft Key Features

When the Soft Key corresponding to a desired feature name is operated, the selected feature name starts to blink on the LCD. The blinking display of available features takes precedence over the display of features specified by the Soft Key pattern.

Note: The Soft Keys can be programmed in System Data to blink, remain steady, have no indication, or display a character when either in use or idle.

The following shows the default display patterns of main features.

FDB (Call Forwarding - Busy Line)

Permits a call to a busy station to be immediately forwarded to a predesignated station.

FDA (Call Forwarding - All Calls)

Permits all calls designated for a particular station to be routed to another station regardless of the busy or idle status of the called station.

FDL (Logged Out IP Station - Call Destination)

Enables a system to transfer the call to appropriate station when Dterm whose LOGGED OUT IP STATION - CALL DESTINATION has already been registered is in logout status.

E-OVR (Executive Override)

Enables selected station users, upon encountering a busy condition at an internal station, to bridge into the busy connection.

CW (Call Waiting)

Enables a busy station to receive a second incoming call. A camp-on indication tone is sent to the busy station, and you can use a switchhook flash to answer the second call.

CB (Call Back)

Provides the ability for a calling station to set a CALL BACK. The calling station will be rung as soon as the busy station becomes available.

S&R (Save and Repeat)

Allows a station to save a specific dialed number and then redial that number later.

MWSET (Message Waiting - Set)

Allows a station to set a Message Waiting indication or lamp.

HOLD (Call Hold)

Permits a station user to hold a call in progress and to return to the previously held call.

MWOFF (Message Waiting - Cancel)

Allows a station to cancel a Message Waiting indication or lamp.

PICK (Call Pickup - Group)

Permits a station user to answer any calls directed to other lines in the user's preset Call Pickup Group.

CONF (Three-way Calling)

Enables a station user to establish a three-way conference by connecting an additional party to an already existing conversation.

VOICE (Voice Call)

Enables you to make a call to the called party's built-in speaker. If the called party's MIC is on, the called party can converse on hands-free.

S-SPD (Speed Calling - System)

Allows a station user to call certain frequently dialed numbers using fewer digits (abbreviated call codes) than would normally be required.

CAS (CAS-Switch Hook Flash)

Allows you to send a switchhook flash while on an outside trunk.

UCDBO (UCD Busy Out)

Allows a station user to block UCD calls and to cancel

Busy Out.

FLASH (Flash)

Provides the station with a switchhook flash.

FDN (Call Forward - No Answer)

Permits a call to an unanswered station to be forwarded to a predesignated station if the called station does not answer within a predetermined period of time.

C-RPT (ISDN Malicious Call Trace)

Allows you to initiate a Call Trace on ISDN calls only.

G-SPD (Speed Calling - Group)

Allows a station user to share a set of common Speed Calling numbers with other station users in the group.

P-RLS (Privacy Release)

Allows another station to depress a busy line key and enter the conversation of a station already engaged in communication.

DND (Do Not Disturb)

Allows a station user to deny access to the station line for incoming calls.

MIC (Microphone On/Off)

Allows you to turn the microphone on and off for use with the speakerphone.

PAGE (Button Page)

Allows you to toggle between pages when two numbers are registered on One-Touch Speed Calling key.

HSET (Headset)

Allows you to go off- and on-hook when using the headset.

RLS (Release Key)

Allows you to release the current call when using the headset, without waiting for the party to hang up.

SIG (Manual Signaling)

Permits station users to send a one-second ring to a predetermined station. If the signaled station is ringing from another call, the manual intercom signal will interrupt that ringing.

CKEEP (Eight-Party Conference Retrain)

Allows all outside parties to stay on a conference when all internal parties hang up.

SCALL (Serial Call)

Allows you to set Serial Call for the caller before extending the call, allowing the caller to receive an announcement at the end of the call guiding the caller to dial the next number and subsequent numbers.

IZP (Internal Zone Paging)

Allows a user to make a voice call through the speakers of the designated group.

IDCHG (Call ID Change Display)

Allows you to toggle between standard display and an alternate display.

GPICK (Call Pickup - Group Enhancement)

Allows you to answer any ringing station within your expanded call pickup group.

CHCNF (Call Hold - Conference)

Allows a station user to establish a conference connection by adding a third party, who is held on another line, to the existing two-party connection.

VISIT (Survivable Remote MGC)

Allows a station to indicate a status: when a user is in remote office, VISIT will be blinking. After recovering the main office, VISIT will return to light.

RMUTE (Ringer Mute)

Allows a station user to mute or recover station ringing.

RVERS:

Allows you to reverse the black and white in its display: background, characters and icons.

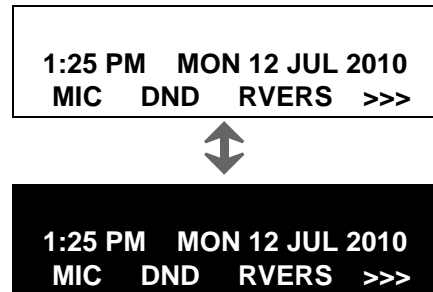

>>> (Display Function Next Page)

Allows you to scroll to the next screen.

<<< (Display Function Previous Page)

Allows you to scroll to the previous screen.

CONDITIONS FOR DT700 SERIES

Please note that following terminal settings (by Feature Key + Digit Key) cannot be used for DT700 Series.

- **Feature+0** =Side Tone On/Off (for handset)
For the settings, contact the Administrator.
** You can confirm the settings in “Audio&Visual Settings” → “Side Tone Volume” of Online Monitoring.*
- **Feature+2** =Adjusts handset receiver volume
For the settings, contact the Administrator.
** You can confirm the settings in “Audio&Visual Settings” → “Audio Settings” → “Receive Bias”/“Receive Gain” of Online Monitoring.*
- **Feature+3** =Selects ringer tone
For the settings, contact the Administrator.
** You can confirm the settings in “Audio&Visual Settings” → “Audio Settings” → “Ring Settings” of Online Monitoring.*
- **Feature+4** =Adjusts transmission/receiving volume
For the settings, contact the Administrator.
** You can confirm the settings in “Audio&Visual Settings” → “Audio Settings” → “Receive Bias”/“Receive Gain”/“Send Gain” of Online Monitoring.*
- **Feature+5** =Activates hands-free operation
Not Available
- **Feature+6** =Deactivates hands-free operation
Not Available

Note: When pressing and holding Help key, the menu of "Online Monitoring" will be displayed. For details on Online Monitoring, see ONLINE MONITORING in Chapter 10.

This page is for your notes.

2. INSTALLATION PROCEDURE

ADJUSTING ANGLE OF TILT LEG

DT730/710 DT330/310

The angle of the tilt leg can be adjusted in four levels.

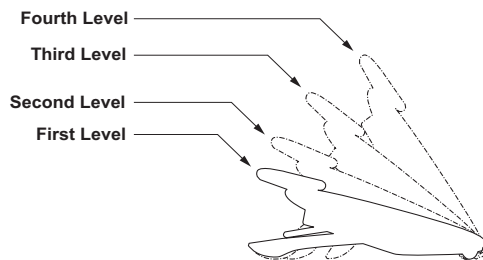

• TO RAISE TILT LEG

STEP 1: Turn the telephone set upside down.

STEP 2: Adjust the tilt leg in the direction of the arrow until you hear it click.

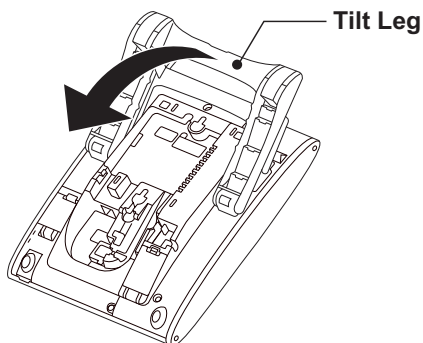

• TO LOWER TILT LEG

STEP 1: Turn the telephone set upside down.

STEP 2: While lifting the center of the stopper, adjust the tilt leg in the direction of the arrow until you hear it click.

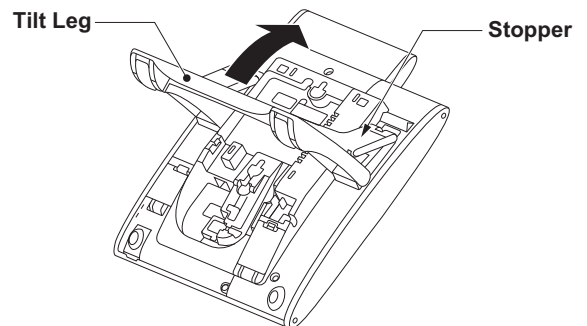

TO REMOVE TILT LEG

DT730/710 DT330/310

- STEP 1: Turn the telephone set upside down.
- STEP 2: Lower the tilt leg to first level.
- STEP 3: Remove the indicated portions (a and b) of the stopper from grooves (A and B) on the tilt leg and then widen the tilt leg.

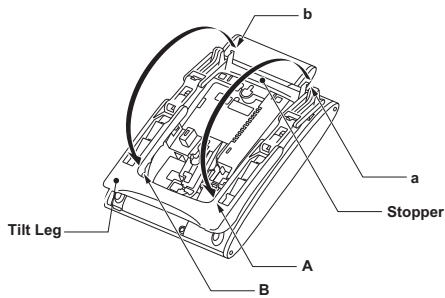

- STEP 4: While pushing the two hooks, slide the tilt leg downward. Remove the tilt leg from the terminal.

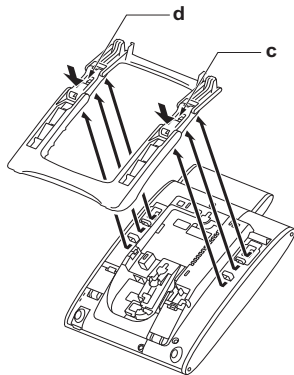

TO ATTACH TILT LEG

DT730/710 DT330/310

- STEP 1: Turn the telephone set upside down.
- STEP 2: Align the hooks (c-h) of the tilt leg over the appropriate slots (C-H) of the telephone set.
- STEP 3: Slide the tilt leg upward until the hooks (c and b) click into place.

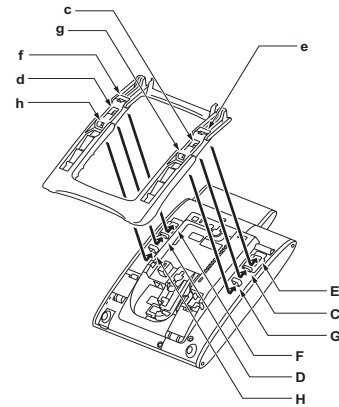

- STEP 4: Fit the indicated portions (a and b) of the stopper into the grooves (A and B) on the tilt leg.

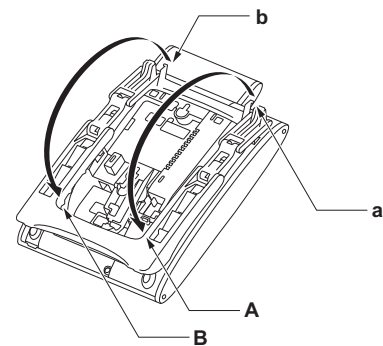

CONNECTING LAN CABLE

DT730/710

STEP 1: Prepare 10 BASE-T/100 BASE-T/TX cables (Straight) for connecting the telephone to network device such as HUB, PoE Switch.

STEP 2: Connect the telephone to the network device using the LAN cable.

STEP 3: Thread the LAN cable through the groove on the back of the telephone.

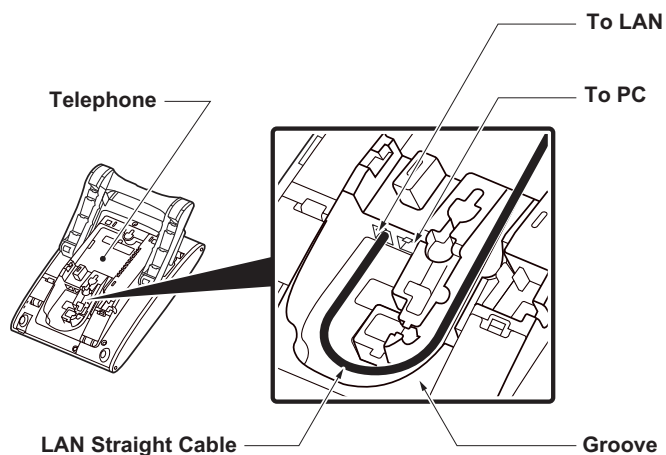

STEP 4: When AC adapter is used to supply power to the telephone, connect the AC/DC adapter to the telephone as shown below.

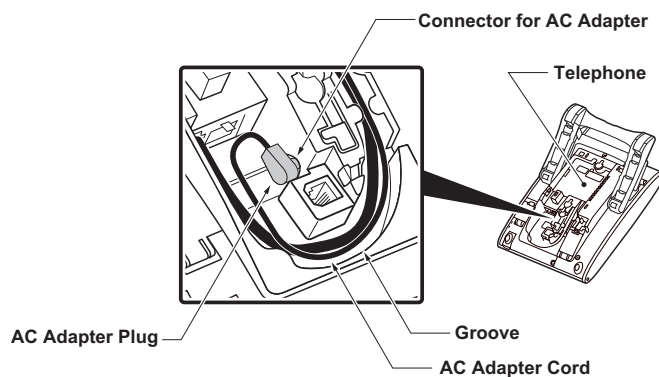

CONNECTING LINE CORD

DT330/DT310

STEP 1: Insert Line cord plug into Line connector on the back of the telephone set until you hear it click.

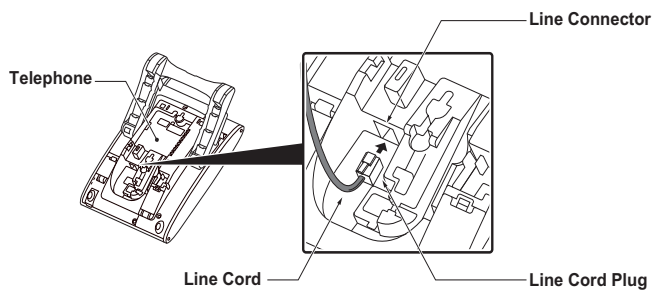

STEP 2: Thread the line cord through the groove on the back of the telephone.

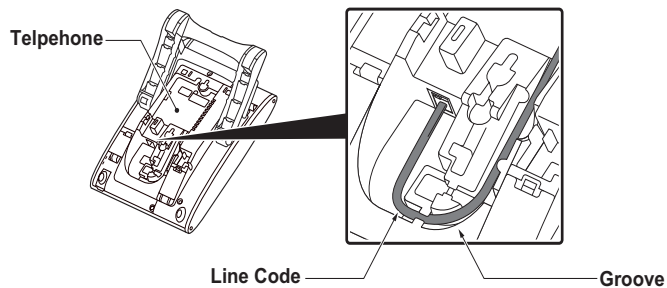

STEP 3: Lead the line cord out through the groove on the tilt leg as shown in the figure below.

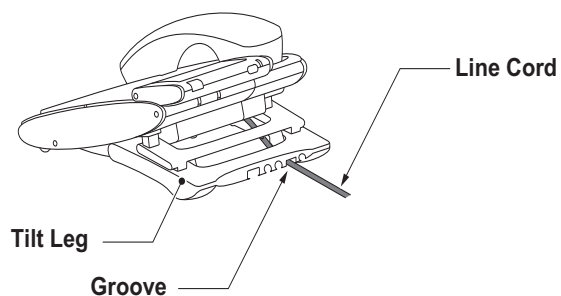

INSTALLING DIRECTORY CARD

DT730/710 DT330/310

A directory card (also known as an abbreviated dialing table) can be attached to the telephone sets. The directory card can be used to record often dialed numbers or other important information. Directory cards are available as options.

Note: To remove the directory card, pinch the two sides of the directory card holder inward until the tabs release and pull the holder out of the grooves.

STEP 1: Remove the protective sheet from the cover.

STEP 2: Attach the cover to the directory card and then attach it to the directory card holder.

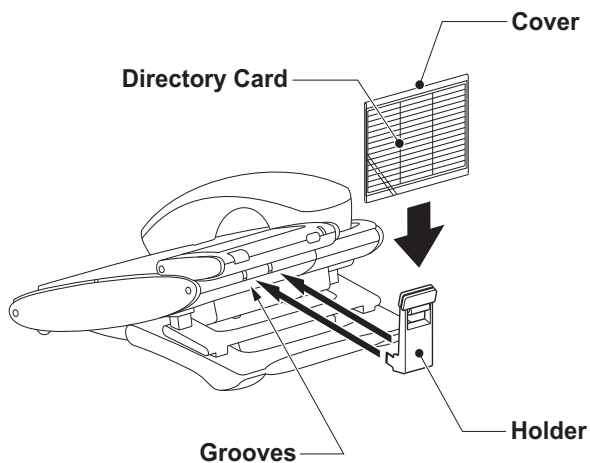

ATTACHING HANDSET

DT730/710 DT330/310

STEP 1: Insert the coiled cord plug into HANDSET connector on the back of the telephone until you hear it click.

STEP 2: Thread the coiled cord through the groove as shown in the figure below.

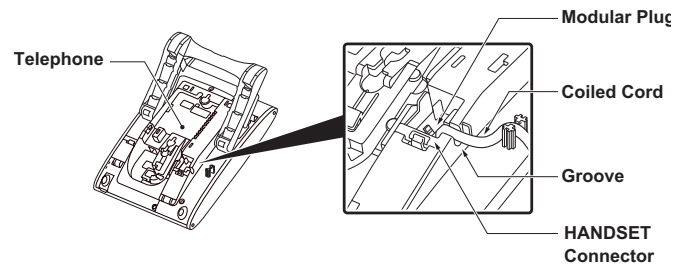

INSTALLING/REMOVING KEY SET UNIT UNIT DT730/710 DT330/310

• TO REMOVE KEY SET UNIT

STEP 1: Insert a tapered rod lightly into the right side of the line key panel/button panel.

STEP 2: Lift out the line key panel/button panel to remove it from the telephone.

STEP 3: Remove the line key card.

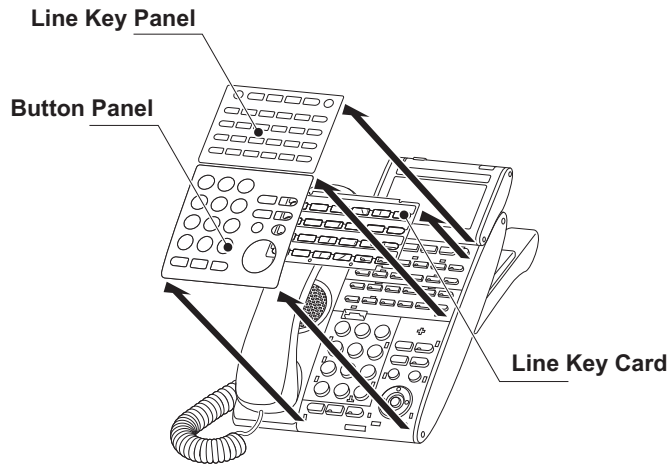

• TO INSTALL KEY SET UNIT

STEP 1: Align the holes in the line key card with the buttons on the telephone.

STEP 2: Align the holes in the line key panel/button panel with the buttons on the telephone and

then push the four corners of the panel until the panel clicks into place.

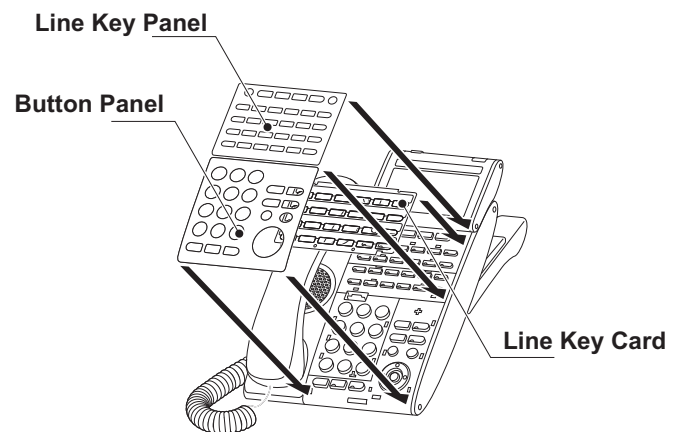

WALL MOUNTING **DT730/710** **DT330/310**

A wall mount unit (WM-L UNIT) is used to mount all telephones to the wall. This unit connects to the back side of the telephone.

	<p>WARNING Be careful not to drop the telephone set while mounting it on the wall. It can cause injury.</p>
	<p>Make sure the telephone set is firmly mounted on the wall to prevent the telephone set from falling out. It can cause injury.</p>

To mount the telephone set on the wall, the following space is required.

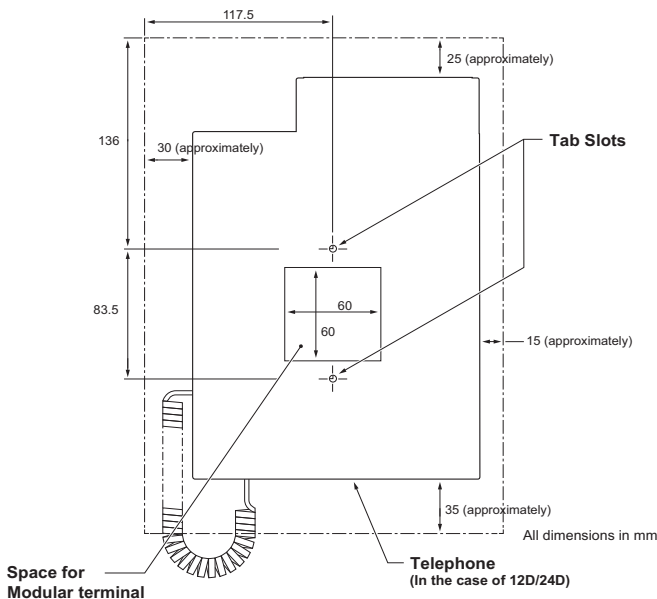

To mount the telephone set on the wall, use the following procedure.

STEP 1: Mount the hanger of the handset upside down.

Remove the hanger from the handset once. Turn it upside down and then insert the hanger until you hear it clicks.

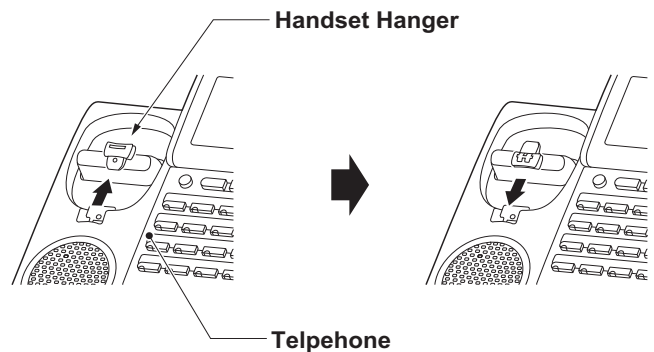

STEP 2: Turn the telephone set upside down and widen the tilt leg.

STEP 3: Attach WM-L UNIT to the wall directly or the wall plate.

- When attaching WM-L UNIT to the wall directly:

Secure WM-L UNIT with the six screws (included with the telephone set) or hang WM-L UNIT on the wall with the two screws (purchased separately) inserted into the wall.

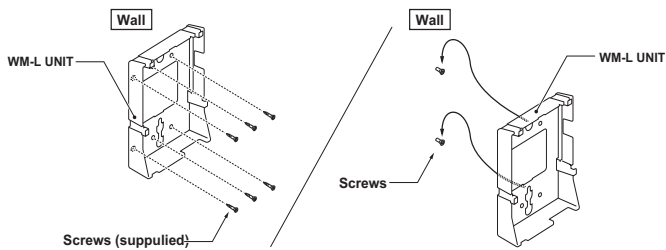

- When attaching WM-L UNIT to the wall plate:
Attach WM-L UNIT to the posts on the wall plate as shown in the figure below.

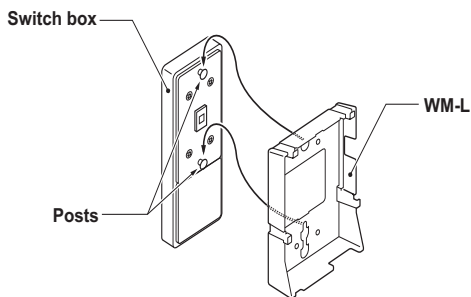

The remainder of the procedure varies between DT300 Series and DT700 Series.

- In the case of DT300 Series: Go to the next step.
- In the case of DT700 Series: Go to Step 8 after the LAN cable is connected to the telephone.

STEP 4: Attach the modular terminal to the wall as shown in the following figure. If the modular connector is attached directly on the wall or the wall plate is used instead of modular terminal, skip this step.

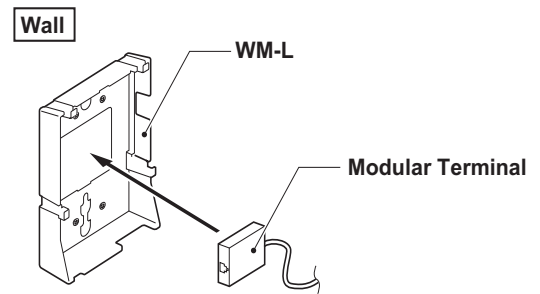

STEP 5: Insert the line cord plug (included with the telephone set) into the modular connector.

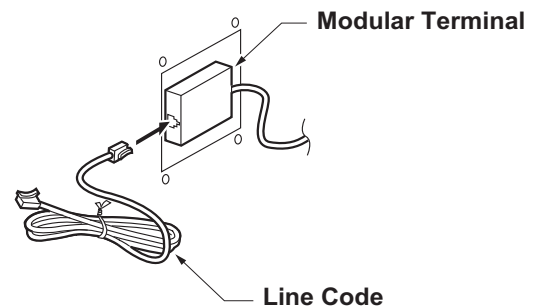

STEP 6: Insert the line cord plug into the LINE connector on the back of the telephone. Wrap the excess cord and secure it with a tie wrap.

STEP 7: Thread the coiled cord through the groove on the back of the telephone as shown in the figure below.

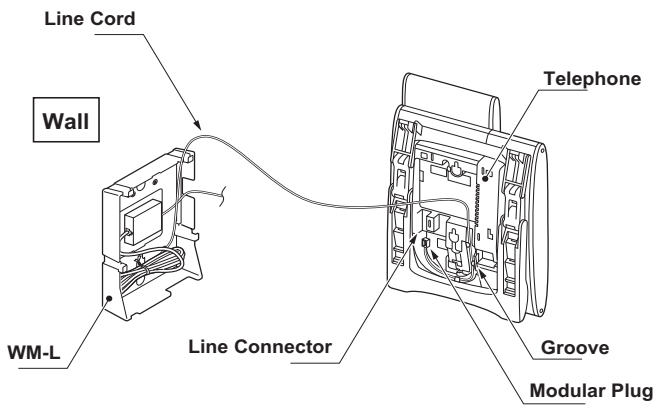

STEP 8: Insert the four tabs on WM-L UNIT in the tab slots on the back of the telephone.
Tuck the excess cord into WM-L UNIT.

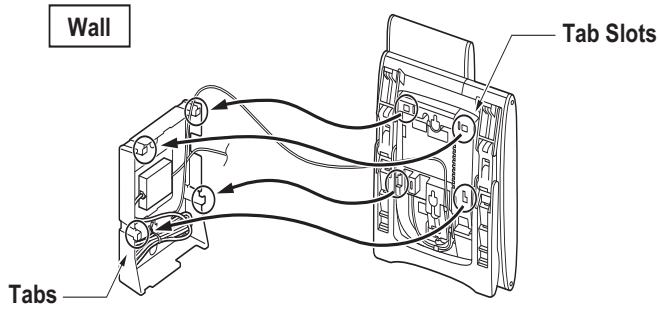

This page is for your notes.

3. TERMINAL SETUP

This chapter describes operating procedures for terminal settings by the **Up/Down** (▲/▼) key, **Feature** key and **Menu** key.

Various terminal settings such as display, sounds, password, and language are also available from **Menu** key.

SETUP WITH UP/DOWN KEY

- **TO ADJUST HANDSET RECEIVER VOLUME** **DT730/710** **DT330/310**

Press **Up/Down** (▲/▼) key in the off-hook status or during the call.

LCD indication for North America, Latin America, Asia, Middle East and Russia



LCD indication for Australia



- **TO ADJUST SPEAKER VOLUME**

DT730/710 **DT330/310**

Press **Up/Down** (▲/▼) key during speakerphone operation or during the call.

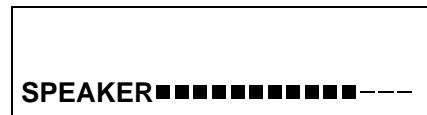

- **TO ADJUST RINGER TONE**

DT730/710 **DT330/310**

Press **Up/Down** (▲/▼) key during ringing.

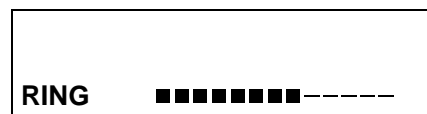

- **TO ADJUST LCD CONTRAST**

DT730/710 DT330/310

Press **Up/Down** ( or ) key in the on-hook status.



SETUP WITH FEATURE KEY

- **MICROPHONE ON/OFF**

DT730/710 DT330/310

LED on  key shows the status of the built-in microphone.

STEP 1: Press soft key associated with the MIC Display or press  and **1** key.

- **TO CHANGE HANDSET RECEIVER VOLUME** **DT330/310**

Handset receiver volume can be changed.

STEP 1: Press  and **2** key. The LCD displays the current volume status.

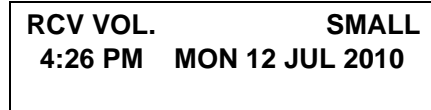

STEP 2: Press  and **2** key to alternate between Large and Small volume.

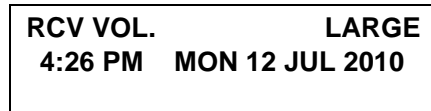

- **TO SELECT RINGER TONE** **DT330/310**

DT Series has 10 kinds of ringer tones that you can select.

STEP 1: Press  and **3** key. The LCD displays the selected tone number (n=1 ~ 10).

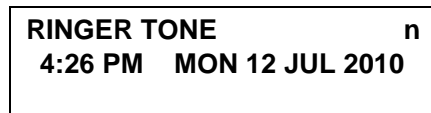

No.	Frequency (Hz)	Modulation (Hz)
1	520/660	16
2	520/660	8
3	1100/1400	16
4	660/760	16
5	Melody 1	
6	Melody 2	
7	Melody 3	

No.	Frequency (Hz)	Modulation (Hz)
8		Melody 4
9		Melody 5
10		Melody 6

Note: Tone number 5, 6, 8~10 (**Melody 1, 2, 4~6**) will sound continuously.

- **TO ADJUST TRANSMISSION/RECEIVING VOLUME** DT330/310

Handset volume can be changed.

STEP 1: Press **Feature** and **4** key. The LCD displays the current volume.

T/R VOL.	SMALL
4:26 PM	MON 12 JUL 2010

STEP 2: Press **Feature** and **4** key again to alternate between Large and Small volume.

T/R VOL.	LARGE
4:26 PM	MON 12 JUL 2010

- **TO ACTIVATE HANDS-FREE** DT330/310

To Set Hands-Free On:

STEP 1: Press **Feature** and **5** key. The LCD displays:

HANDS FREE	ON
4:26 PM	MON 12 JUL 2010

To Set Hands-Free Off:

STEP 1: Press **Feature** and **6** key. The LCD displays:

HANDS FREE	OFF
4:26 PM	MON 12 JUL 2010

- **CALL INDICATOR LAMP ON/OFF** DT730/710 DT330/310

You can choose to turn the call indicator lamp either on or off during ringing.

STEP 1: Press **Feature** and **7** key. The LCD displays:

INDICATOR	ON
4:26 PM	MON 12 JUL 2010
INDICATOR	OFF
4:26 PM	MON 12 JUL 2010

Note: The call indicator lamp lights when used as a Message Waiting Lamp, even when it is turned off by the above operation.

- **SELECT DIAL MODE** DT730/710 DT330/310

You can select one pattern from Normal, Dynamic Dial Pad or Preset Dial to originate a call.

When only Dynamic Dial Pad is activated:

To Set/Reset Dynamic Dial Pad

STEP 1: Press **Feature** and **8** key. The LCD displays:

Direct Dial Pad ON 4:26 PM MON 12 JUL 2010
Direct Dial Pad OFF 4:26 PM MON 12 JUL 2010

Note: When this feature is ON, you may initiate a call by immediately dialing the number and the station will go hands-free off-hook automatically. For details, see [TO ORIGINATE A CALL USING SELECTIVE DIALING \(DYNAMIC DIAL PAD, PRESET DIAL\)](#).

When only Preset Dial is activated:

To Set/Reset Preset Dial

STEP 1: Press **Feature** and **8** key. The LCD displays:

Preset Dial ON 4:26 PM MON 12 JUL 2010
Preset Dial OFF 4:26 PM MON 12 JUL 2010

Note: When this feature is ON, you may initiate a call by pressing Speaker Key or going off-hook after dialing the number. For details, see [TO ORIGINATE A CALL USING SELECTIVE DIALING \(DYNAMIC DIAL PAD, PRESET DIAL\)](#)

When both Dynamic Dial Pad and Preset Dial are activated:

To Set Dial Mode

STEP 1: Every time **Feature** and **8** key are pressed, Dial Mode switches. The LCD displays:

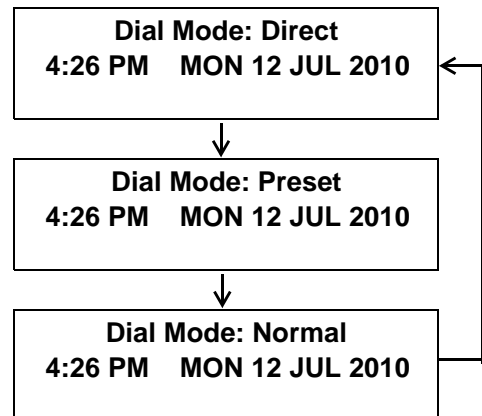

Note: It means that Dial Mode displayed on LCD is ON.



SETUP WITH MENU KEY FOR DT700 SERIES

• TO ENABLE/DISABLE OFF-HOOK RINGING **DT730/DT710**

The procedure below shows how to enable/disable Off-hook ringing.



STEP 1: While indicating the current time on LCD, press **Menu** key to open the **Menu** screen.

STEP 2: Select **5 Setting** (DT730) / **2 Setting** (DT710)

- Select an item by either of the following operations.
- Highlight an item by using , and then press , or **OK** soft key.
 - Press **5** key (DT730) / **2** key (DT710)



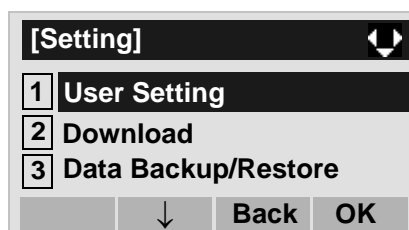

STEP 3: Select **1 User Setting**.

- Select an item by either of the following operations.
- Highlight an item by using , and then press , or **OK** soft key.
 - Press **1** key.



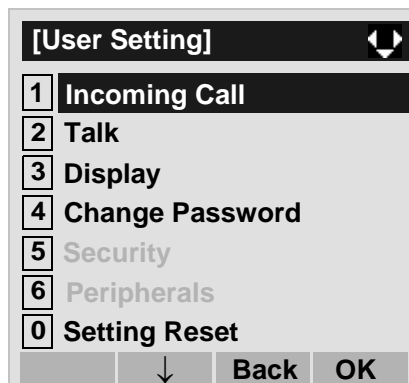

STEP 4: Select **1 Incoming Call**.

- Select an item by either of the following operations.
- Highlight an item by using , and then press , or **OK** soft key.
 - Press **1** key.



STEP 5: Select **2 Offhook Ring** (DT730) / **1 Off-hook Ring** (DT710)

- Select an item by either of the following operations.
- Highlight an item by using , and then press ,



- Press  or **OK** soft key.
- Press **2** key (DT730) / **1** key (DT710)



STEP 6: To disable/enable the off-hook ringing, select

1 Disable or **2 Enable**.

Select an item by one of the following operations.

- Highlight an item by using , and then press  or **OK** soft key.
- Press **1** or **2** key, and then press  or **OK** soft key.



Note: Default setting is **2 Enable**.



Note: The enabled item is highlighted.

• **TO SET RINGING OF HEADSET DT730**

The procedure below shows how to enable/disable the ringing of headset.



STEP 1: While indicating the current time on LCD, press **Menu** key to open the **Menu** screen.

STEP 2: Select **5 Setting**.

- Select an item by either of the following operations.
- Highlight an item by using , and then press , or **OK** soft key.
 - Press **5** key.



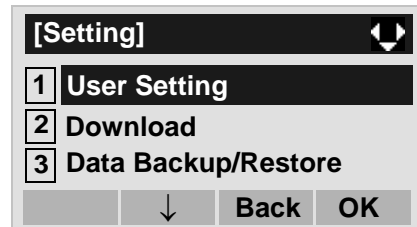

STEP 3: Select **1 User Setting**.

- Select an item by either of the following operations.
- Highlight an item by using , and then press , or **OK** soft key.
 - Press **1** key.



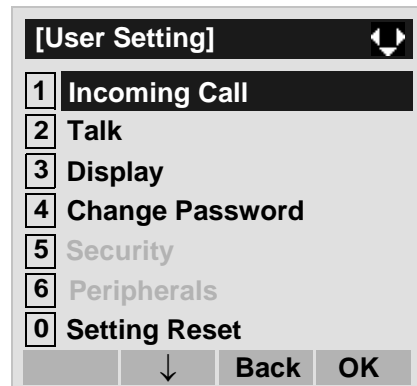

STEP 4: Select **1 Incoming Call**.

- Select an item by either of the following operations.
- Highlight an item by using , and then press , or **OK** soft key.
 - Press **1** key.





STEP 5: Select **3 Headset Ring**.

- Select an item by either of the following operations.
- Highlight an item by using , and then press , or **OK** soft key.
 - Press **3** key.



STEP 6: To disable/enable the ringing of headset, select **1 Disable** or **2 Enable**.

Select an item by one of the following operations.

- Highlight an item by using , and then press  or **OK** soft key.
- Press **1** or **2** key, and then press  or **OK** soft key.



Note: Default setting is **1 Disable**.



Note: The enabled item is highlighted.

• **TO SET RINGER TONE** **DT730/DT710**

The procedure below shows how to change the ringer tone for internal call and external call.



STEP 1: While indicating the current time on LCD, press **Menu** key to open the **Menu** screen.

STEP 2: Select **5 Setting** (DT730) / **2 Setting** (DT710)

- Select an item by either of the following operations.
- Highlight an item by using , and then press ,  or **OK** soft key.
 - Press **5** key (DT730) / **2** key (DT710)



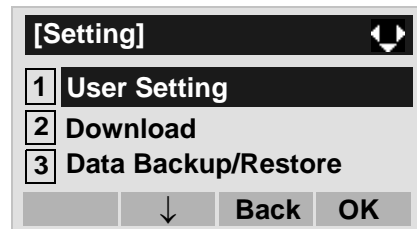

STEP 3: Select **1 User Setting**.

- Select an item by either of the following operations.
- Highlight an item by using , and then press ,  or **OK** soft key.
 - Press **1** key.



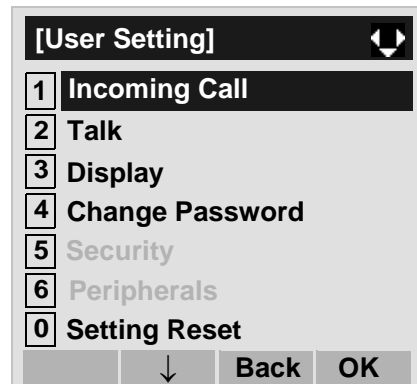

STEP 4: Select **1 Incoming Call**.

- Select an item by either of the following operations.
- Highlight an item by using , and then press ,  or **OK** soft key.
 - Press **1** key.



STEP 5: Select **4 Ring Tone** (DT730) / **2 Ring Tone** (DT710)

- Select an item by either of the following operations.
- Highlight an item by using , and then press ,  or **OK** soft key.
 - Press **4** key (DT730) / **2** key (DT710)



STEP 6: Select **1 External Call** when setting the ringer tone for external calls. Select **2 Internal Call** when setting the ringer tone for internal calls.

- Select an item by either of the following operations.
- Highlight an item by using , and then press , or **OK** soft key.
 - Press **1** or **2** key.



STEP 7: Select a desired tone type. You can preview designated ringer tone.

- Select an item by either of the following operations.
- Highlight an item by using , and then press or **OK** soft key.
 - Press **0** - **9** key, and then press or **OK** soft

key.
For example, press **1** + **5** to select **15 Download1**.

Note: The enabled item is highlighted.

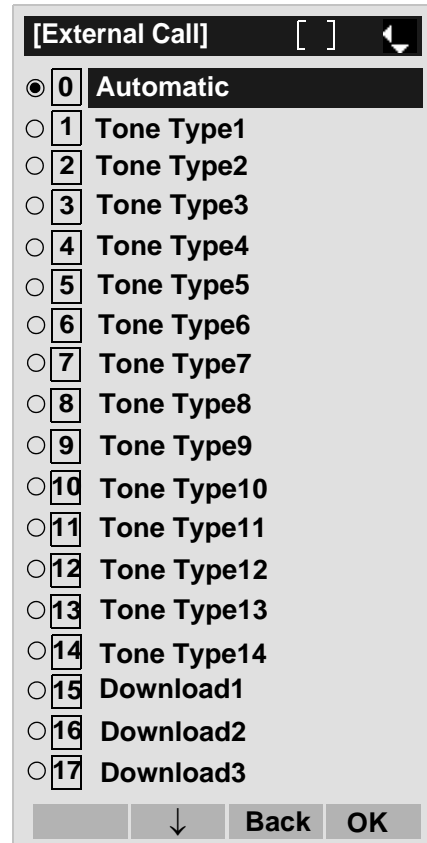

No.	Menu Item	Frequency (Hz)		Remarks
		1st	2nd	
0	Automatic	520	660	16Hz modulation
1	Tone Type1	520	660	16Hz modulation

No.	Menu Item	Frequency (Hz)		Remarks
		1st	2nd	
2	Tone Type2	520	660	8Hz modulation
3	Tone Type3	1400	1100	Door Phone
4	Tone Type4	1100		No modulation
5	Tone Type5	540		No modulation
6	Tone Type6	1100	1400	16Hz modulation
7	Tone Type7	660	760	16Hz modulation
8	Tone Type8	1100		Envelope
9	Tone Type9	-		Door Phone Melody
10	Tone Type10	-		Melody 1
11	Tone Type11	-		Melody 2
12	Tone Type12	-		Melody 3
13	Tone Type13	-		Melody 4
14	Tone Type14	-		Melody 5
15	Download1	-		DT730 only
16	Download2	-		DT730 only
17	Download3	-		DT730 only

Note: Terminal settings may not become effective, according as the system settings. For details, contact the System Administrator.

Note: You can set ringer tone for the telephone set here. Ringer Tone type can be set for "Name", "Group" and "Telephone set". The ringer Tone type set for "Name" has higher priority than the types set for "Group" and "Terminal set".

Note: When selecting **Automatic** or not performing this ringer tone setting, **Tone Type 1** is automatically applied.

Note: When selecting **Automatic**, the preview function will not operate. Also, when selecting **Download 1/2/3**, the ringer tone file must be downloaded in advance. If there is no downloaded file, you hear no tone.



Note: Tone Type 1 to Tone Type 8:
In the preview function, each ringer tone sounds continuously. Actual ringer pattern of each tone is determined by the initial system settings.

• **TO SET ILLUMINATION PATTERN FOR CALL INDICATION LAMP** **DT730**

The procedure below shows how to set the illumination pattern (color of Call Indicator Lamp).



STEP 1: While indicating the current time on LCD, press **Menu** key to open the **Menu** screen.

STEP 2: Select **5 Setting**.

- Select an item by either of the following operations.
- Highlight an item by using , and then press , or **OK** soft key.
 - Press **5** key.



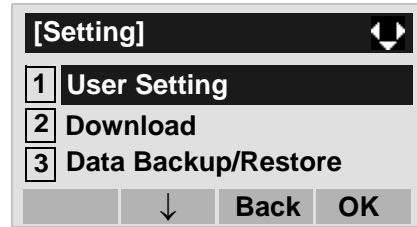

STEP 3: Select **1 User Setting**.

- Select an item by either of the following operations.
- Highlight an item by using , and then press , or **OK** soft key.
 - Press **1** key.



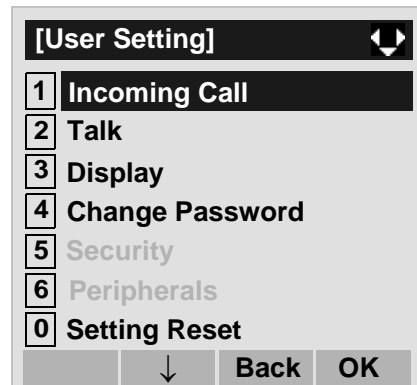

STEP 4: Select **1 Incoming Call**.

- Select an item by either of the following operations.
- Highlight an item by using , and then press , or **OK** soft key.
 - Press **1** key.



STEP 5: Select **5 Illumination**.

- Select an item by either of the following operations.
- Highlight an item by using , and then press , or **OK** soft key.
 - Press **5** key.



STEP 6: Select **1 External Call** when setting the illumination pattern for external calls. Select **2 Internal Call** when setting the illumination pattern for internal call.

Select an item by one of the following operations.

- Highlight an item by using , and then press , or **OK** soft key.
- Press **1** or **2** key.

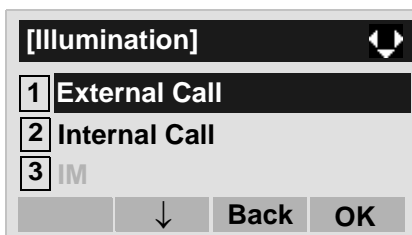

STEP 7: Select a desired illumination pattern. You can preview the designated illumination pattern.

Select an item by either of the following operations.

- Highlight an item by using , and then press or **OK** soft key.

- Press **0** - **9** key, and then press or **OK** soft key.

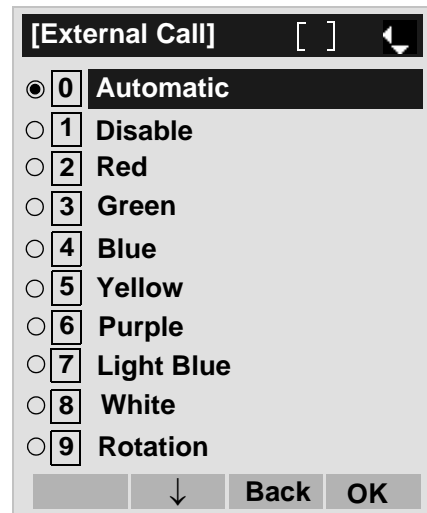

Note: When selecting **Automatic**, the preview function will not operate.

Note: When selecting **Automatic** or not performing this illumination setting, **Red** is automatically applied.

Note: You can set illumination pattern for the telephone set here. Illumination pattern can be set for "Name", "Group" and "Telephone set". The illumination pattern set for "Name" has higher priority than the patterns set for "Group" and "Terminal set".

• **TO ENABLE/DISABLE RTP ALARM**

DT730/DT710

The procedure below shows how to enable/disable RTP alarm.

STEP 1: While indicating the current time on LCD, press  key to open the **Menu** screen.

STEP 2: Select **5** **Setting** (DT730) / **2** **Setting** (DT710)

Select an item by either of the following operations.

- Highlight an item by using , and then press ,  or **OK** soft key.
- Press **5** key (DT730) / **2** key (DT710)



STEP 3: Select **1** **User Setting**.

Select an item by either of the following operations.

- Highlight an item by using , and then press ,  or **OK** soft key.
- Press **1** key.

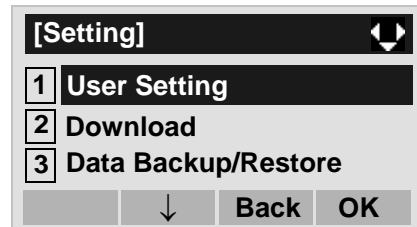

STEP 4: Select **2** **Talk**.

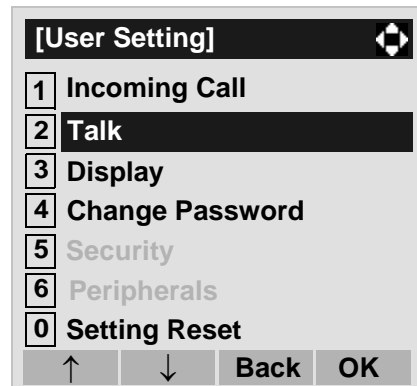

Select an item by either of the following operations.

- Highlight an item by using , and then press ,  or **OK** soft key.
- Press **2** key.



STEP 5: Select **1** **RTP Alarm**.

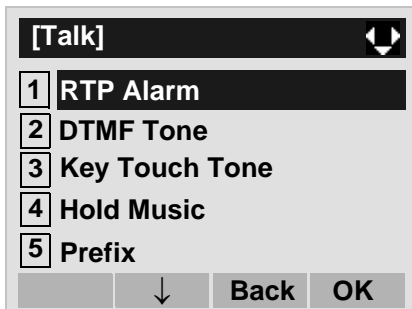

Select an item by either of the following operations.

- Highlight an item by using , and then press ,  or **OK** soft key.
- Press **1** key.



STEP 6: Select **0 Automatic**, **1 Disable** or **2 Enable** (see the following table).

Select an item by either of the following operations.

- Highlight an item by using , and then press  or **OK** soft key.
- Press **0** - **2** key, and then press  or **OK** soft key.

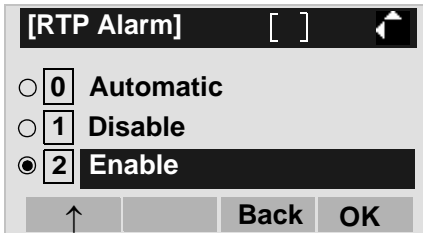

Note: For the setting on the System, contact the System Administrator.

Note: The enabled item is highlighted.

Menu Items	Descriptions
0 Automatic	Follow the setting on the System. If no setting is made in the System, the default setting (Alarm=ON) is applied.
1 Disable	Follow the setting on the terminal (OFF).
2 Enable	Follow the setting on the terminal (ON).

• **TO ENABLE/DISABLE DTMF TONE**

DT730/DT710

The procedure below shows how to enable/disable DTMF Tone.

STEP 1: While indicating the current time on LCD, press  key to open the **Menu** screen.

STEP 2: Select **5** **Setting** (DT730) / **2** **Setting** (DT710)

Select an item by either of the following operations.

- Highlight an item by using , and then press ,  or **OK** soft key.
- Press **5** key (DT730) / **2** (DT710)



STEP 3: Select **1** **User Setting**.

Select an item by either of the following operations.

- Highlight an item by using , and then press ,  or **OK** soft key.
- Press **1** key.

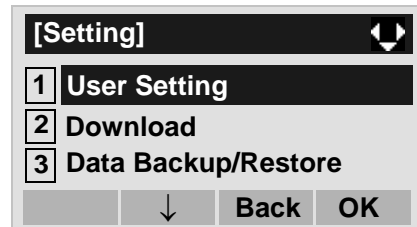

STEP 4: Select **2** **Talk**.

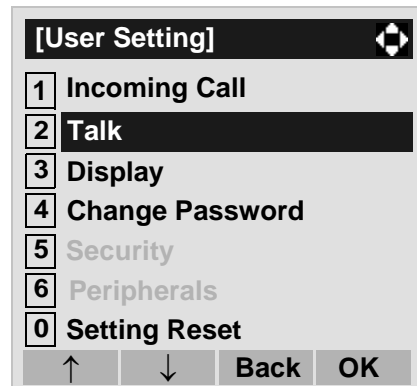

Select an item by either of the following operations.

- Highlight an item by using , and then press ,  or **OK** soft key.
- Press **2** key.



STEP 5: Select **2** **DTMF Tone**.

Select an item by either of the following operations.

- Highlight an item by using , and then press ,  or **OK** soft key.
- Press **2** key.

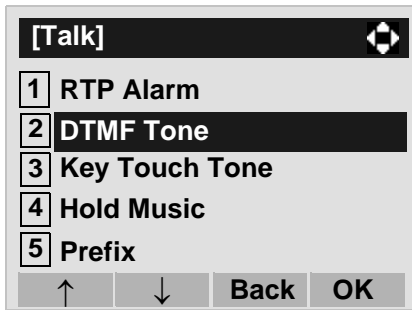

STEP 6: Select **0 Automatic**, **1 Disable** or **2 Enable** (see the following table).

Select an item by either of the following operations.

- Highlight an item by using , and then press or **OK** soft key.
- Press **0** - **2** key, and then press or **OK** soft key.

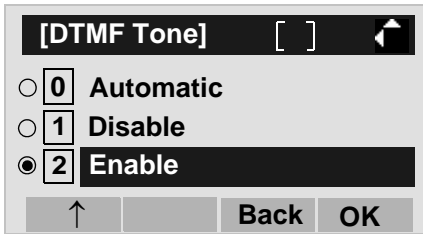

Menu Items	Descriptions
0 Automatic	Follow the setting on the System. If no setting is made in the System, the default setting (DTMF=ON) is applied.
1 Disable	Follow the setting on the terminal (OFF).
2 Enable	Follow the setting on the terminal (ON).

Note: For the setting on the System, contact the System Administrator.

Note: The enabled item is highlighted.



• **TO SET KEY TOUCH TONE**

DT730/DT710

The procedure below shows how to set Key Touch Tone. Key Touch Tone is a tone generated when the digit keys are pressed while DT Series is off-hook.



STEP 1: While indicating the current time on LCD, press **Menu** key to open the **Menu** screen.

STEP 2: Select **5 Setting** (DT730) / **2 Setting** (DT710)

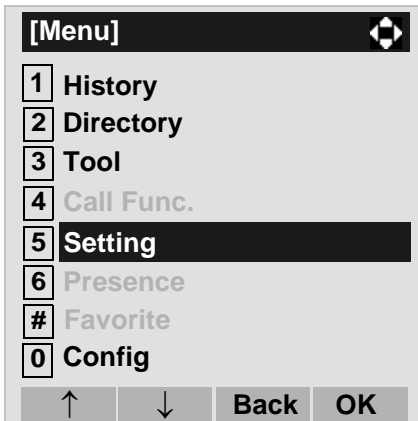
- Select an item by either of the following operations.
- Highlight an item by using , and then press ,  or **OK** soft key.
 - Press **5** key (DT730) / **2** key (DT710)





STEP 3: Select **1 User Setting**.

- Select an item by either of the following operations.
- Highlight an item by using , and then press ,  or **OK** soft key.

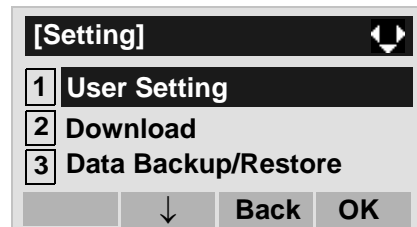
- Press **1** key.





STEP 4: Select **2 Talk**.

- Select an item by either of the following operations.
- Highlight an item by using , and then press ,  or **OK** soft key.
 - Press **2** key.



STEP 5: Select **3 Key Touch Tone**.

- Select an item by either of the following operations.
- Highlight an item by using , and then press ,  or **OK** soft key.
 - Press **3** key.

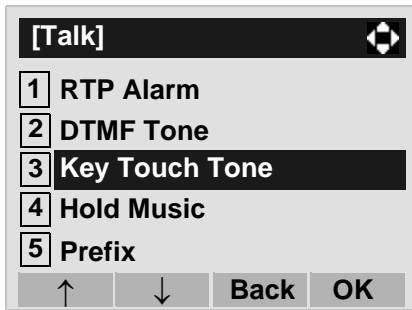

STEP 6: Select **0 Automatic**, **1 No Tone**, **2 Tone** or **3 Voice**.

Select an item by either of the following operations.

- Highlight an item by using , and then press or **OK** soft key.
- Press **0** - **3** key, and then press or **OK** soft key.

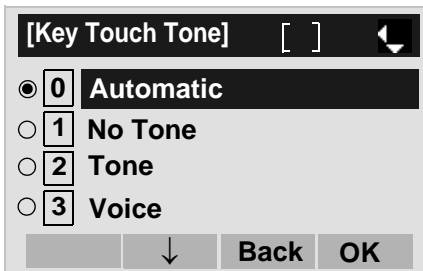

Note: When **0 Automatic** is set, the default setting (Tone) is applied.

Note: The enabled item is highlighted.



Note: **3 Voice** can be selected on DT730 only.

• **TO SET MUSIC ON HOLD** **DT730/DT710**

The procedure below shows how to set Music on Hold to be heard by DT Series user.



STEP 1: While indicating the current time on LCD, press **Menu** key to open the **Menu** screen.

STEP 2: Select **5 Setting** (DT730) / **2 Setting** (DT710)

- Select an item by either of the following operations.
- Highlight an item by using , and then press ,  or **OK** soft key.
 - Press **5** key (DT730) / **2** key (DT710)



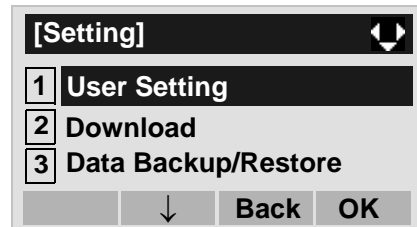

STEP 3: Select **1 User Setting**.

- Select an item by either of the following operations.
- Highlight an item by using , and then press ,  or **OK** soft key.
 - Press **1** key.



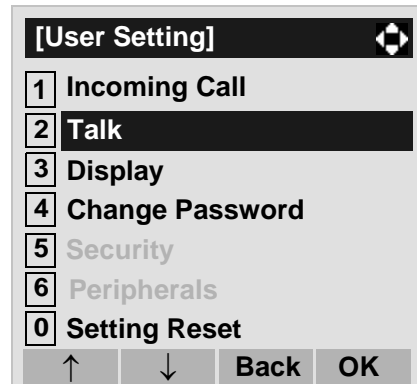

STEP 4: Select **2 Talk**.

- Select an item by either of the following operations.
- Highlight an item by using , and then press ,  or **OK** soft key.
 - Press **2** key.



STEP 5: Select **4 Hold Music**.

- Select an item by either of the following operations.
- Highlight an item by using , and then press ,  or **OK** soft key.
 - Press **4** key.

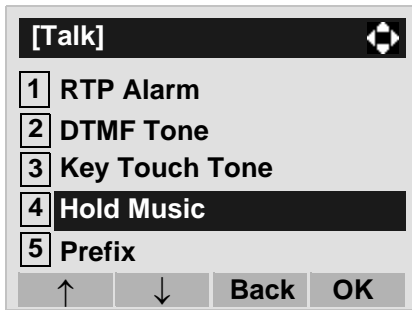



Note: You can preview the designated music on hold. When selecting Download, the music on hold file must be downloaded in advance. If there is no downloaded file, you hear no tone in the preview function (in actual operating conditions, “Minuet” is automatically applied.).

STEP 6: Select a desired Music on Hold. You can preview the designated Music on Hold.

Select **1 Default** when the default data (Minuet) is used as Music on Hold. Select **2 Download** when a downloaded data is used as Music on Hold.

Select an item by either of the following operations.

- Highlight an item by using , and then press  or **OK** soft key.
- Press **1** or **2** key, and then press  or **OK** soft key.

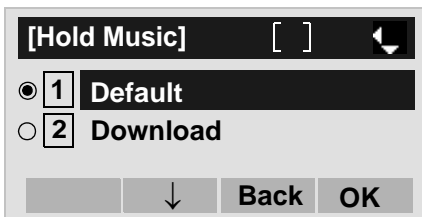



• **TO SET CLOCK FORMAT** **DT730/DT710**

Determines whether time is displayed with a 12-hour or 24-hour clock format.

Note: This setting is available for Time Display only. Call Log feature displays the time in 24-hour format regardless of this setting (DT730).



STEP 1: While indicating the current time on LCD, press  key to open the **Menu** screen.

STEP 2: Select **5 Setting** (DT730) / **2 Setting** (DT710)

- Select an item by either of the following operations.
- Highlight an item by using , and then press , or **OK** soft key.
 - Press **5** key (DT730) / **2** key (DT710)





STEP 3: Select **1 User Setting**.

- Select an item by either of the following operations.
- Highlight an item by using , and then press ,

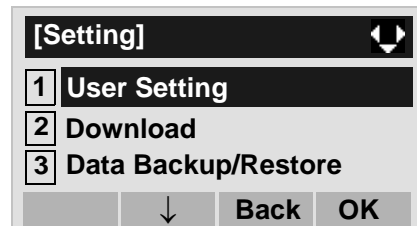
- Press  or **OK** soft key.
- Press **1** key.



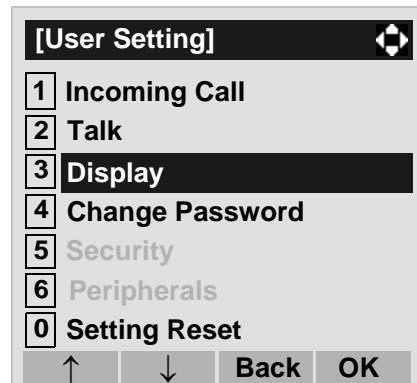

STEP 4: Select **3 Display**.

- Select an item by either of the following operations.
- Highlight an item by using , and then press ,
 - Press  or **OK** soft key.
 - Press **3** key.



STEP 5: Select **1 Time Format**.

- Select an item by either of the following operations.
- Highlight an item by using , and then press ,
 - Press  or **OK** soft key.
 - Press **1** key.

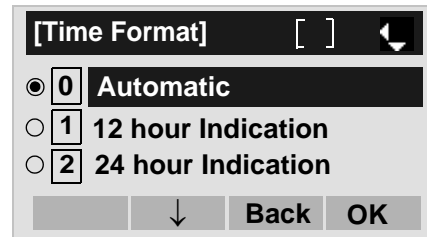
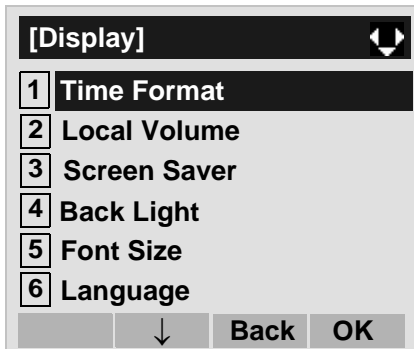

STEP 6: Make a selection from the following list.

Select an item by either of the following operations.

- Highlight an item by using , and then press or **OK** soft key.
- Press **0** - **2** key, and then press or **OK** soft key.

Menu Item	Meaning
0 Automatic	Follow the setting on the system. (default)
1 12 hour Indication	12-hour clock
2 24 hour Indication	24-hour clock

Note: For the setting on the System, contact the System Administrator.



Note: The enabled item is highlighted.

• **TO ENABLE/DISABLE VOLUME LEVEL DISPLAY DT730/DT710**

Determines whether or not to display the following volume levels: handset receiver volume, speaker volume, ringer tone volume and LCD contrast.



STEP 1: While indicating the current time on LCD, press  key to open the **Menu** screen.

STEP 2: Select **5 Setting** (DT730) / **2 Setting** (DT710)

- Select an item by either of the following operations.
- Highlight an item by using , and then press ,  or **OK** soft key.
 - Press **5** key (DT730) / **2** key (DT710)





STEP 3: Select **1 User Setting**.

- Select an item by either of the following operations.
- Highlight an item by using , and then press ,  or **OK** soft key.

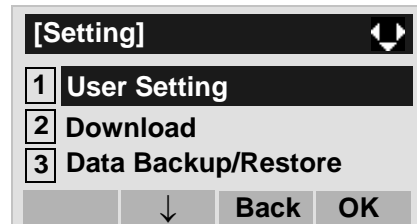
• Press **1** key.





STEP 4: Select **3 Display**.

- Select an item by either of the following operations.
- Highlight an item by using , and then press ,  or **OK** soft key.
 - Press **3** key.



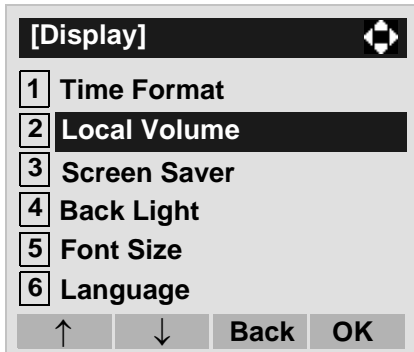

STEP 5: Select **2 Local Volume**.

- Select an item by either of the following operations.
- Highlight an item by using , and then press ,  or **OK** soft key.
 - Press **2** key.



STEP 6: Make a selection from the following list.

Select an item by either of the following operations.

- Highlight an item by using , and then press  or **OK** soft key.
- Press **0** - **2** key, and then press  or **OK** soft key.

Menu Item	Meaning
0 Automatic	Each volume level is displayed on LCD (default).
1 Disable	Each volume level is not displayed on LCD.
2 Enable	Each volume level is displayed on LCD.

Note: The enabled item is highlighted.

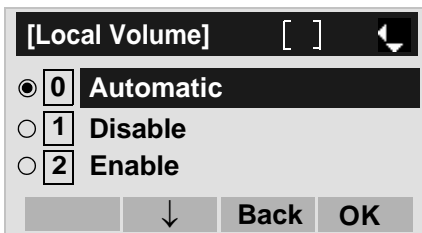



• **TO SET SCREEN SAVER** **DT730/DT710**

Screen Saver works after the telephone is idle for a certain period of time. The latest Screen Saver contents will be displayed from XML server when the Screen Saver works. If the latest contents can not be downloaded from XML server, default Screen Saver will be displayed.

Note: For details on the XML service, contact the System Administrator.



STEP 1: While indicating the current time on LCD, press **Menu** key to open the **Menu** screen.

STEP 2: Select **5 Setting** (DT730) / **2 Setting** (DT710) on the **Menu** screen.

- Select an item by either of the following operations.
- Highlight an item by using , and then press , or **OK** soft key.
 - Press **5** key (DT730) / **2** key (DT710)



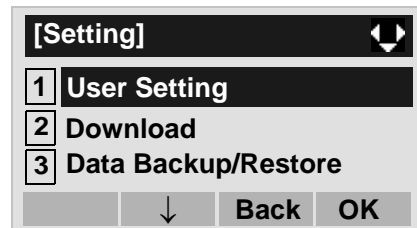

STEP 3: Select **1 User Setting**.

- Select an item by either of the following operations.
- Highlight an item by using , and then press , or **OK** soft key.
 - Press **1** key.





STEP 4: Select **3 Display**.

- Select an item by either of the following operations.
- Highlight an item by using , and then press , or **OK** soft key.
 - Press **3** key.



STEP 5: Select 3 Screen Saver.

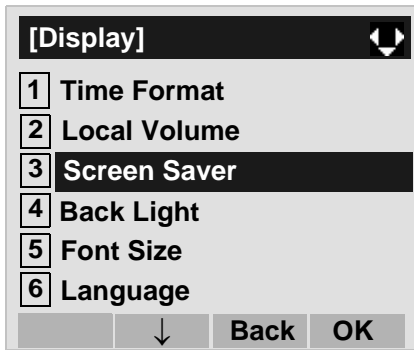

Select an item by either of the following operations.

- Highlight an item by using , and then press ,  or **OK** soft key.
- Press 3 key.



STEP 6: Select 1 Screen Saver Mode.



Select an item by either of the following operations.

- Highlight an item by using , and then press ,  or **OK** soft key.
- Press 1 key.



STEP 7: Select either 1 Disable or 2 Enable.

Select an item by one of the following operations.

- Highlight an item by using , and then press ,  or **OK** soft key.

- Press 1 or 2 key, and then press  or **OK** soft key.

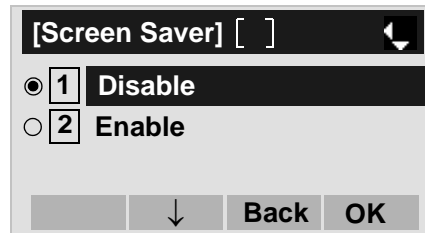

Note: Default setting is 1 **Disable**.

Note: The enabled item is highlighted.

STEP 8: The display goes back to the **Screen Saver screen. When 2 **Enable** is selected Step 7, Select 2 **Wait Time**.**

Input **Wait Time** to launch the screen saver (1-999min) and then press  or **OK** soft key.

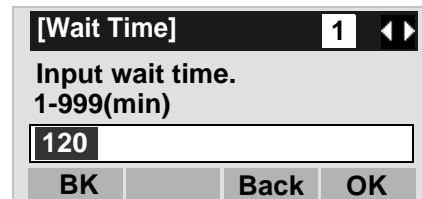

Note: Default value is 120 min.

• **TO ENABLE/DISABLE BACKLIGHT**



DT730

The following explains how to enable/disable the backlights of LCD and digit keys.

The backlights illuminate (for approximately 10 seconds) when you press any key or lifts the handset.



STEP 1: While indicating the current time on LCD, press **Menu** key to open the **Menu** screen.

STEP 2: Select **5 Setting**.

- Select an item by either of the following operations.
- Highlight an item by using , and then press , or **OK** soft key.
 - Press **5** key.



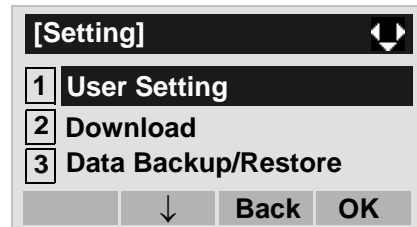

STEP 3: Select **1 User Setting**.

- Select an item by either of the following operations.
- Highlight an item by using , and then press , or **OK** soft key.
 - Press **1** key.





STEP 4: Select **3 Display**.

- Select an item by either of the following operations.
- Highlight an item by using , and then press , or **OK** soft key.
 - Press **3** key.



STEP 5: Select **4 Back Light**.

- Select an item by either of the following operations.
- Highlight an item by using , and then press , or **OK** soft key.
 - Press **4** key.

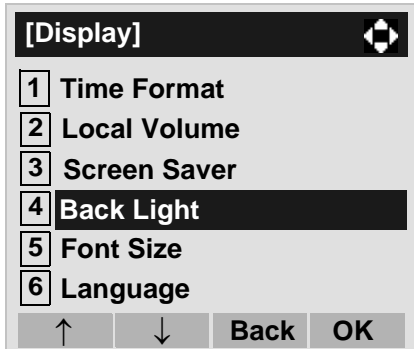

STEP 6: Make a selection from the following list.

Select an item by either of the following operations.

- Highlight an item by using , and then press or **OK** soft key.
- Press **1** or **2** key, and then press or **OK** soft key.

Menu Item	Meaning
1 Disable	Backlights of LCD and digit keys are disabled.
2 Enable	Backlights of LCD and digit keys are enabled.

Note: The enabled item is highlighted.

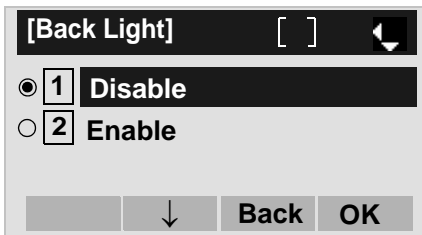



• **TO CHANGE CHARACTER SIZE** **DT730**

The following explains how to change the displayed character size on the LCD.



STEP 1: While indicating the current time on LCD, press **Menu** key to open the **Menu** screen.

STEP 2: Select **5 Setting**.

- Select an item by either of the following operations.
- Highlight an item by using , and then press ,  or **OK** soft key.
 - Press **5** key.



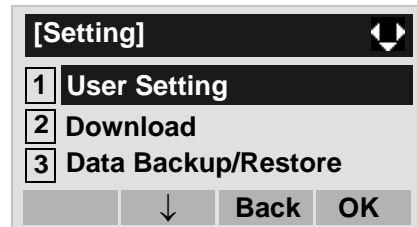

STEP 3: Select **1 User Setting**.

- Select an item by either of the following operations.
- Highlight an item by using , and then press ,  or **OK** soft key.
 - Press **1** key.





STEP 4: Select **3 Display**.

- Select an item by either of the following operations.
- Highlight an item by using , and then press ,  or **OK** soft key.
 - Press **3** key.



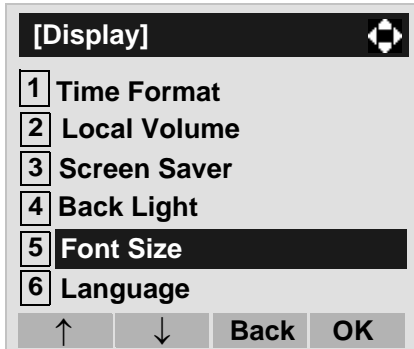

STEP 5: Select **5 Font Size**.

- Select an item by either of the following operations.
- Highlight an item by using , and then press ,  or **OK** soft key.
 - Press **5** key.



STEP 6: Select either "Standard(16dot)" or "Small(12dot)".

Select an item by either of the following operations.

- Highlight an item by using , and then press  or **OK** soft key.
- Press **1** or **2** key, and then press  or **OK** soft key.





Note: The enabled item is highlighted.

• **TO SET A LANGUAGE** **DT730/DT710**

The following explains how to set a language to be displayed on LCD.



STEP 1: While indicating the current time on LCD, press **Menu** key to open the **Menu** screen.

STEP 2: Select **5 Setting** (DT730) / **2 Setting** (DT710)

- Select an item by either of the following operations.
- Highlight an item by using , and then press , or **OK** soft key.
 - Press **5** key (DT730) / **2** key (DT710)



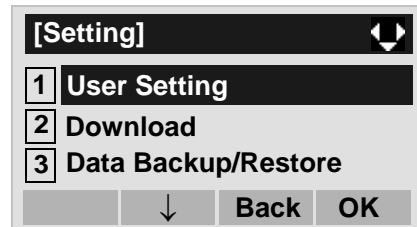

STEP 3: Select **1 User Setting**.

- Select an item by either of the following operations.
- Highlight an item by using , and then press , or **OK** soft key.
 - Press **1** key.



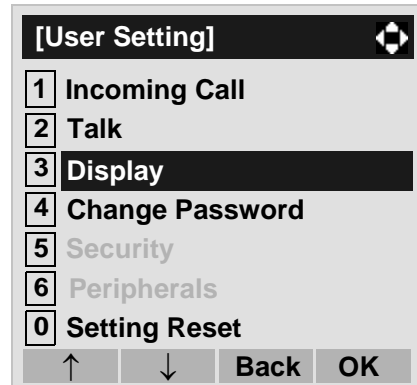

STEP 4: Select **3 Display**.

- Select an item by either of the following operations.
- Highlight an item by using , and then press , or **OK** soft key.
 - Press **3** key.



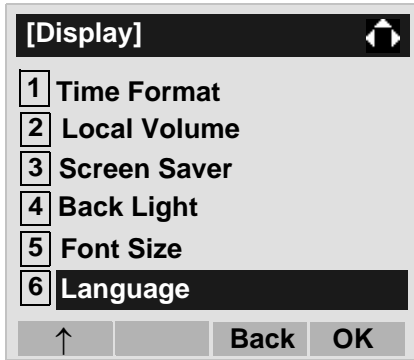

STEP 5: Select **6 Language** (DT730) / **4 Language** (DT710)

- Select an item by either of the following operations.
- Highlight an item by using , and then press , or **OK** soft key.
 - Press **6** key (DT730) / **4** key (DT710)



STEP 6: Select a desired language.

Select an item by either of the following operations.

- Highlight an item by using , and then press  or **OK** soft key.
- Press **0** - **9** key, and then press  or **OK** soft key.

For example, press **1** + **5** to select **15** Spanish.



Note: The enabled item is highlighted.

STEP 7: After Making a selection, press  or **OK** soft key.



• **TO CHANGE PASSWORD** **DT730/DT710**

To change an existing password, follow the procedure below. This password is used for the following occasions.

- To lock/unlock the telephone.
- To delete the directory data.
- To reset the telephone settings.



STEP 1: While indicating the current time on LCD, press **Menu** key to open the **Menu** screen.

STEP 2: Select **5 Setting** (DT730) / **2 Setting** (DT710)

- Select an item by either of the following operations.
- Highlight an item by using , and then press , or **OK** soft key.
 - Press **5** key (DT730) / **2** key (DT710)



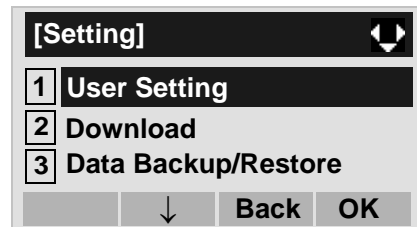

STEP 3: Select **1 User Setting**.

- Select an item by either of the following operations.
- Highlight an item by using , and then press , or **OK** soft key.
 - Press **1** key.



STEP 4: Select **4 Change Password**.

- Select an item by either of the following operations.
- Highlight an item by using , and then press , or **OK** soft key.
 - Press **4** key.

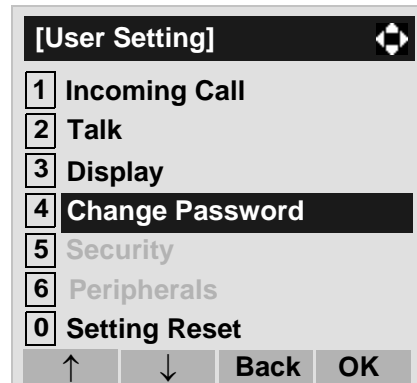

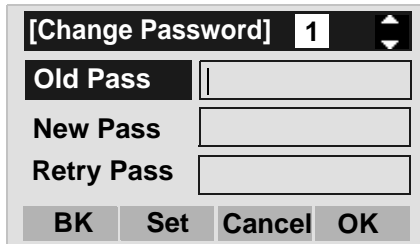

STEP 5: The **Change Password** screen is displayed. Enter the old password and then press  or **Set** soft key.

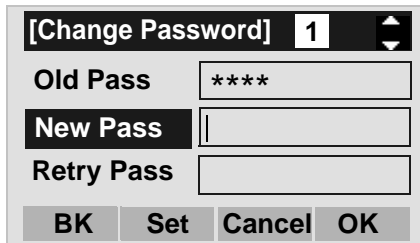

Note: The initial password is "0000". When changing the password for the first time, enter "0000" as the old password.

STEP 6: Enter the new password and then press  or **Set** soft key.



STEP 7: Enter the new password again and then press  or **OK** soft key.

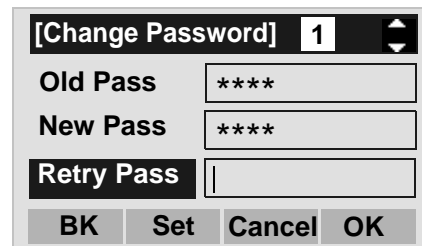

Note: A maximum of 32 digits (0-9, * and #) can be set as a password.

STEP 8: When the password entry completes successfully, the display changes as follows. Press  or **OK** soft key.

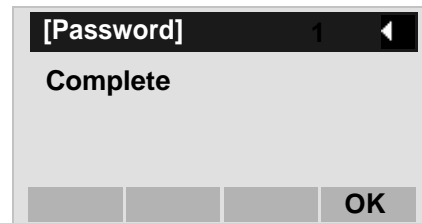

Note: When the password entry ends in failure, the following error message is issued. In that case, press **OK** soft key and try again.

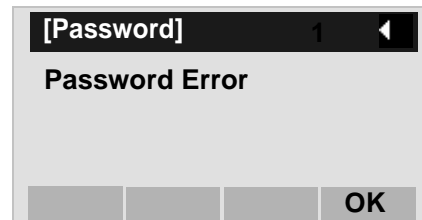



• **TO RESET TELEPHONE SETTINGS**

DT730/DT710

The following explains how to clear the personal data off the telephone.



STEP 1: While indicating the current time on LCD, press **Menu** key to open the **Menu** screen.

STEP 2: Select **5 Setting** (DT730) / **2 Setting** (DT710)

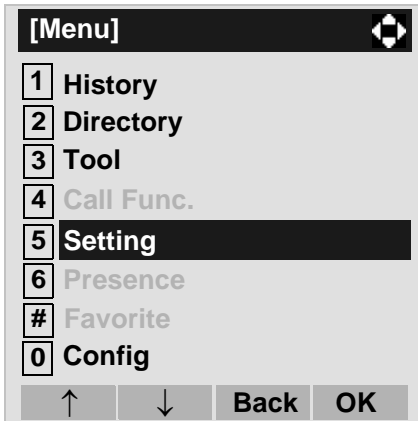
- Select an item by either of the following operations.
- Highlight an item by using , and then press , or **OK** soft key.
 - Press **5** key (DT730) / **2** key (DT710)



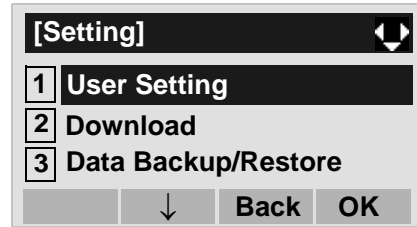

STEP 3: Select **1 User Setting**.

- Select an item by either of the following operations.
- Highlight an item by using , and then press , or **OK** soft key.
 - Press **1** key.



STEP 4: Select **0 Setting Reset**.

- Select an item by either of the following operations.
- Highlight an item by using , and then press , or **OK** soft key.
 - Press **0** key.

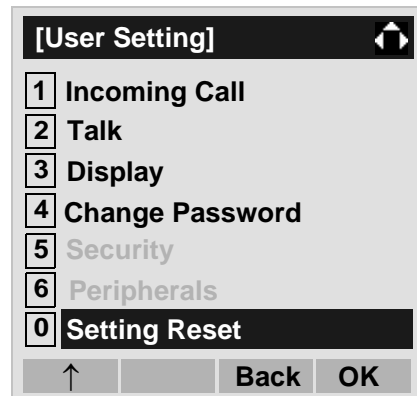

STEP 5: Enter the password and then press  or **OK** soft key.

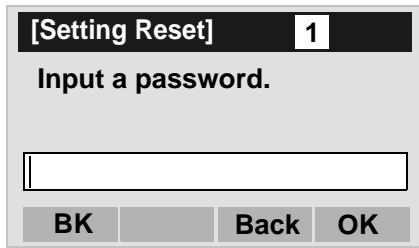

STEP 6: Press  or **OK** soft key to clear the personal data of the telephone.

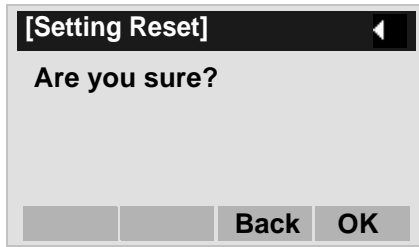

• **TO DOWNLOAD A FILE** **DT730/DT710**

DT730 Series user can download files for Music on Hold, Ringer Tone and Directory. When downloading these files, the DT Series needs to be connected to the network that has FTP (TFTP server).

Note: For details on the FTP/TFTP service, contact the System Administrator.

Before starting the download, an IP Address of the FTP/TFTP Server must be entered from DT Series.

STEP 1: Set up the FTP/TFTP server.



<FTP server>

Put the downloading file into the designated directory (for Windows IIS, the default is "C:\inetPub\ftproot) of the FTP server.

<TFTP server>



Put the downloading file into a desired directory of TFTP server and then specify it as the directory for downloading.

STEP 2: Select **5 Setting** (DT730) / **2 Setting** (DT710) on the **Menu** screen.

- Select an item by either of the following operations.
- Highlight an item by using , and then press , or **OK** soft key.
 - Press **5** key (DT730) / **2** key (DT710)



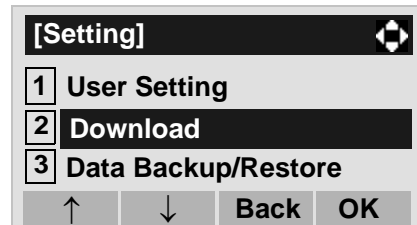

STEP 3: Select **2 Download**.

- Select an item by either of the following operations.
- Highlight an item by using , and then press , or **OK** soft key.
 - Press **2** key.



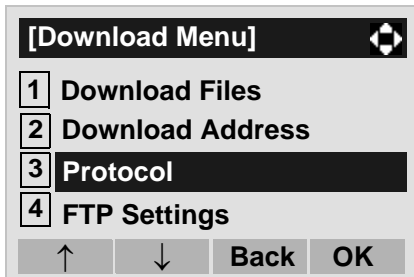

STEP 4: Select **3 Protocol**.

- Select an item by either of the following operations.
- Highlight an item by using , and then press , or **OK** soft key.
 - Press **3** key.



STEP 5: Select a protocol used by the server which stores the download file.

Select an item by either of the following operations.

- Highlight an item by using , and then press  or **OK** soft key.
- Press **1** or **2** key, and then press  or **OK** soft key.

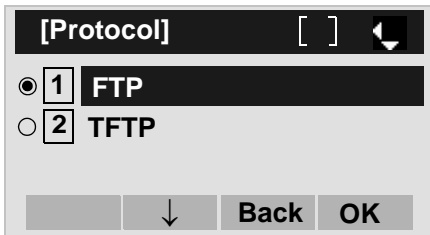



STEP 6: The display goes back to the **Download Menu** screen.

When **1** **FTP** is selected here, go to the next Step (STEP 7).

When **2** **TFTP** is selected here, go to the next STEP 15.

STEP 7: Select **4** **FTP Settings**.

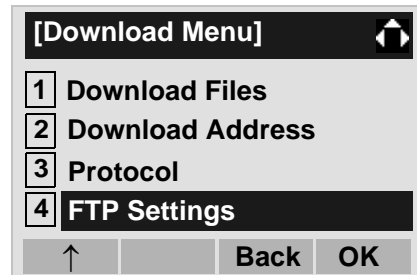

Select an item by either of the following operations.

- Highlight an item by using , and then press ,  or **OK** soft key.
- Press **4** key.



STEP 8: Select **1** **User ID**.

Select an item by either of the following operations.

- Highlight an item by using , and then press ,  or **OK** soft key.
- Press **1** key.

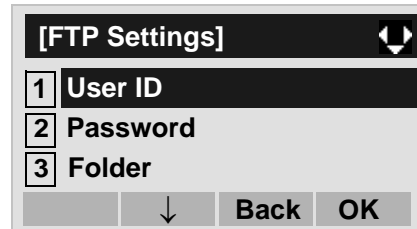

STEP 9: Enter a User ID by using digit keys, then press  or **OK** soft key.



Note: For details on character entry method, see [HOW TO INPUT CHARACTERS](#) in chapter 4 Basic Operation.

STEP 10: The display goes back to the **FTP Settings** screen. Select **2 Password**.

- Select an item by either of the following operations.
- Highlight an item by using , and then press , or **OK** soft key.
 - Press **2** key.

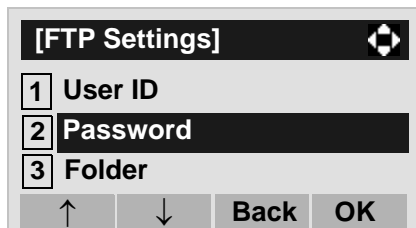

STEP 11: Enter a password by using digit keys, then press or **OK** soft key.

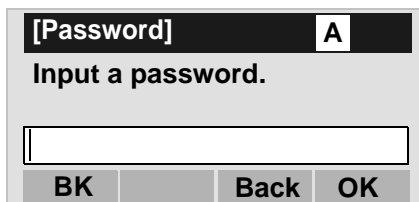

Note: For details on character entry method, see [HOW TO INPUT CHARACTERS](#) in chapter 4 Basic Operation.

STEP 12: The display goes back to the **FTP Settings** screen. Select **3 Folder**.

- Select an item by either of the following operations.
- Highlight an item by using , and then press , or **OK** soft key.
 - Press **3** key.

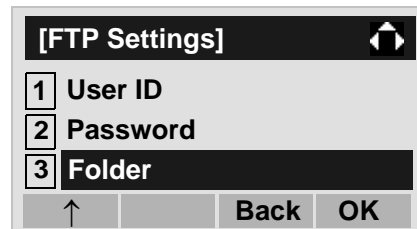

STEP 13: Enter the directory where the download file is stored and then press or **OK** soft key.

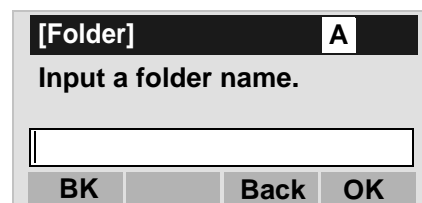

Note: For details on character entry method, see [HOW TO INPUT CHARACTERS](#) in chapter 4 Basic Operation.

STEP 14: The display goes back to the **FTP Settings** screen. Press or **Back** soft key to display

the **Download Menu** screen.

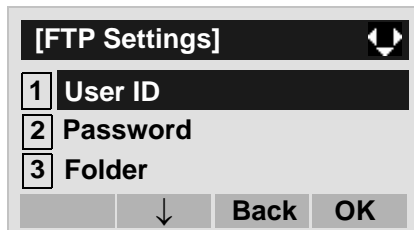

STEP 15: Select **2 Download Address**.

- Select an item by either of the following operations.
- Highlight an item by using , and then press , or **OK** soft key.
 - Press **2** key.

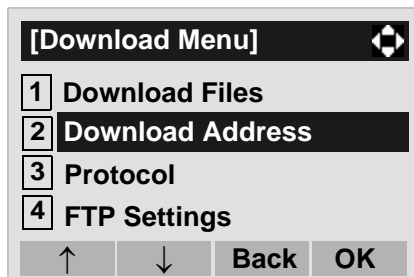

STEP 16: Enter an IP address of the FTP/TFTP server which stores the download file. For example, to set the IP address of 10.41.208.205, enter 10*41*208*205 [separate with an asterisk (*)].

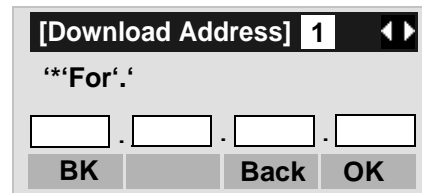

After entering an IP address, press or **OK** soft key.

STEP 17: The display goes back to the **Download Menu** screen. Select **1 Download Files**.

- Select an item by either of the following operations.
- Highlight an item by using , and then press , or **OK** soft key.
 - Press **1** key.

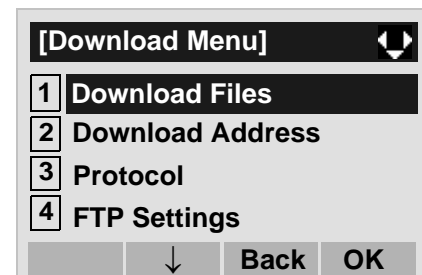

STEP 18: Select a file to be downloaded.

When downloading a file : Select **1 Hold Music** and go for Music on Hold to **STEP 20**.

When downloading a file : Select **2 Ring Tone** and go for ringer tone to **STEP 19**.

When downloading a file : Select **3 Directory** and go for directory to **STEP 20**.



Note: DT710 can select 1 Hold Music only.

STEP 19: When 2 Ring Tone is selected at STEP 18, the following Ring Tone screen is displayed. Select either 1 Download1, 2 Download2 or 3 Download3.

- Select an item by either of the following operations.
- Highlight an item by using , and then press , or OK soft key.
 - Press 1 - 3 key.

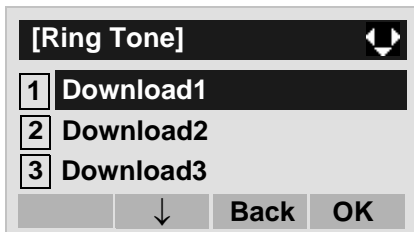

STEP 20: The default file name will be displayed.

- When downloading a file for Music on Hold, the default file name is "MOH.wav".

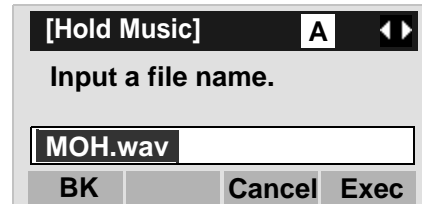

File Format	Maximum Size
PCM μ -law 8kHz/s wav.	under 32 seconds

- When downloading a file for ringer tone, the default file name is "Melody1/2/3/.wav".



File Format	Maximum Size
PCM μ -law 8kHz/s wav.	under 32 seconds

- When downloading a file for Directory, the default file name is "Directory.csv".



File Name	Directory.csv (Fixed)
Code	Unicode (UTF-8)

When changing the file name, go to the next step (**STEP 21**).

When not changing the file name, go to **STEP 22**.

STEP 21: Press **BK** soft key once to delete the default file name and then enter a new file name by using the digit keys.

Note: For details on character entry method, see [HOW TO INPUT CHARACTERS](#) in chapter 4 Basic Operation.

Note: A maximum of 20 characters ("0-9", "A-Z", "a-z", "*", "#", ".", "-" or "_") can be entered as a file name.

Note: To delete an entered character, press **BK** soft key.

STEP 22: Press  or **Exec** soft key to start the downloading process. While downloading a file, the LCD displays "Downloading..." first and then "Saving...".

Note: Be sure not to turn OFF the DT700 Series while "Saving..." is displayed on the LCD.

STEP 23: After the downloading process is complete, the display changes as follows:

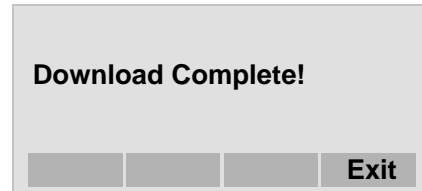

The display goes back to the **Download Files** screen by **Exit** soft key.

Note: When the downloading process ends in failure, "Downloading Failed!" is displayed on the LCD. Check to see the following and then retry.

Check Points	Actions
Download file is not placed in the specified directory.	Place the download file in the specified directory.
A different file name is specified between DT700 Series and FTP/TFTP server.	Set the same file name from both DT700 Series and FTP/TFTP server.
Incorrect IP address of FTP/TFTP server has been entered from the telephone.	Set the proper IP address of FTP/TFTP server.
The power to FTP/TFTP server or network equipment is OFF.	Turn on the power.
LAN cable is disconnected.	Reconnect the cable securely.

• **TO BACKUP PERSONAL SETTINGS**

DT730/DT710

DT730\DT710 Series user can backup personal settings of DT Series to FTP/TFTP server. To back up the setting data, the DT Series needs to be connected to the network that has FTP (TFTP server).

Note: For details on the FTP/TFTP service, contact the System Administrator.

Before starting the backup, an IP Address of the FTP/TFTP Server must be entered from DT Series.

STEP 1: Set up the FTP/TFTP server.



<FTP server>

Confirm the designated directory (for Windows IIS, the default is "C:\inetPub\ftproot) for the backed up file.

<TFTP server>



Specify a desired destination directory for the backed up file.

STEP 2: Select **5 Setting** (DT730) / **2 Setting** (DT710) on the **Menu** screen.

- Select an item by either of the following operations.
- Highlight an item by using , and then press , or **OK** soft key.
 - Press **5** key (DT730) / **2** key (DT710)



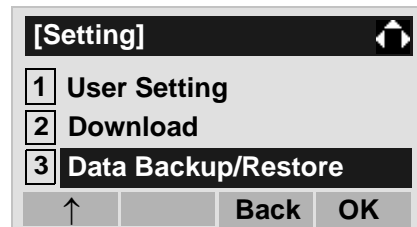

STEP 3: Select **3 Data Backup/Restore**.

- Select an item by either of the following operations.
- Highlight an item by using , and then press , or **OK** soft key.
 - Press **3** key.



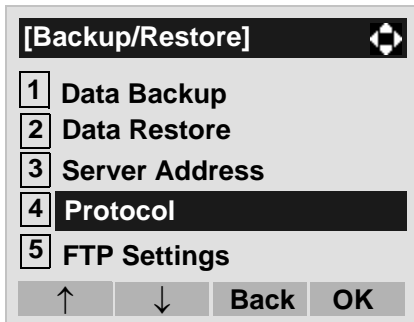

STEP 4: Select **4 Protocol**.

- Select an item by either of the following operations.
- Highlight an item by using , and then press , or **OK** soft key.
 - Press **4** key.



STEP 5: Select a protocol used by the destination server.

Select an item by either of the following operations.

- Highlight an item by using , and then press  or **OK** soft key.
- Press **(1)** or **(2)** key, and then press  or **OK** soft key.

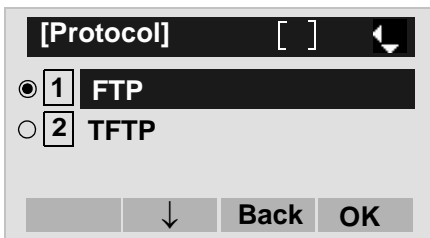

STEP 6: The display goes back to the **Backup/Restore** screen.

When **(1) FTP** is selected here, go to the next Step (STEP 7).

When **(2) TFTP** is selected here, go to the next STEP 15.

STEP 7: Select **(5) FTP Settings**.

Select an item by either of the following operations.

- Highlight an item by using , and then press ,  or **OK** soft key.
- Press **(5)** key.

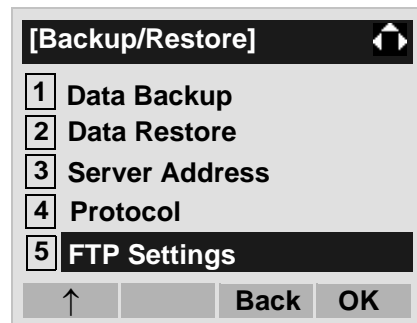

STEP 8: Select **(1) User ID**.

Select an item by either of the following operations.

- Highlight an item by using , and then press ,  or **OK** soft key.
- Press **(1)** key.

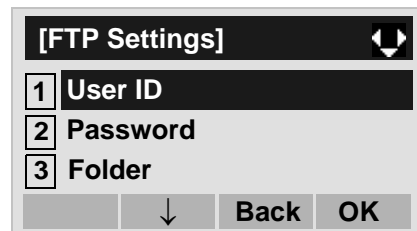

STEP 9: Enter a User ID by using digit keys, then press  or **OK** soft key.

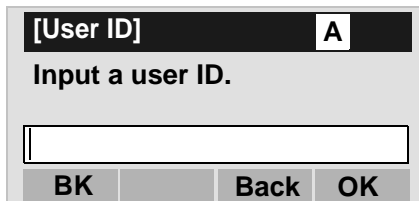

Note: For details on character entry method, see [HOW TO INPUT CHARACTERS](#) in chapter 4 Basic Operation.

STEP 10: The display goes back to the **FTP Settings** screen. Select **2 Password**.

- Select an item by either of the following operations.
- Highlight an item by using , and then press or **OK** soft key.
 - Press **2** key.

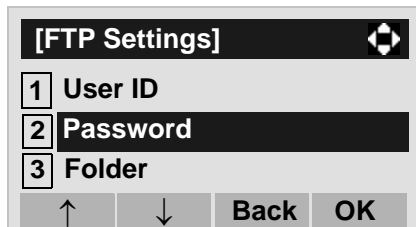

STEP 11: Enter a password by using digit keys, then press or **OK** soft key.

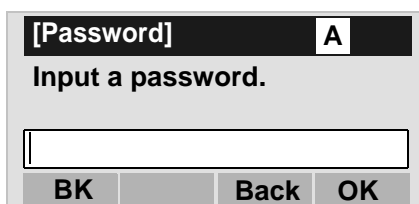

Note: For details on character entry method, see [HOW TO INPUT CHARACTERS](#) in chapter 4 Basic Operation.

STEP 12: The display goes back to the **FTP Settings** screen. Select **3 Folder**.

- Select an item by either of the following operations.
- Highlight an item by using , and then press or **OK** soft key.
 - Press **3** key.

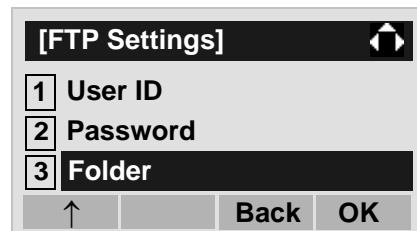

STEP 13: Enter the destination directory of the FTP/TFTP server and then press or **OK** soft key.

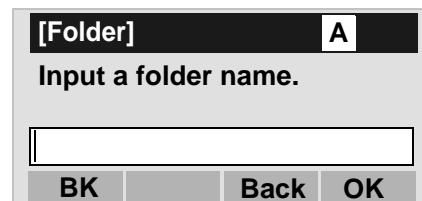

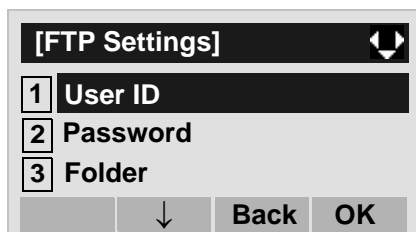

Note: For details on character entry method, see [HOW TO INPUT CHARACTERS](#) in chapter 4 Basic Operation.

STEP 14: The display goes back to the **FTP Settings** screen. Press  or **Back** soft key to display the **Backup/Restore** screen.



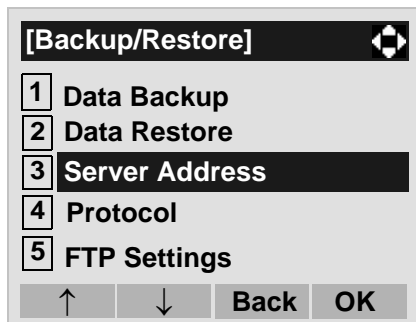

STEP 15: Select **3 Server Address**.

- Select an item by either of the following operations.
- Highlight an item by using , and then press ,  or **OK** soft key.
 - Press **3** key.



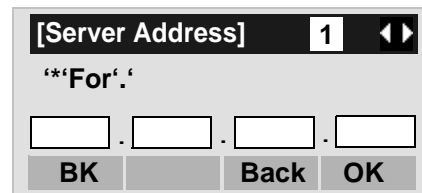

STEP 16: Enter an IP address of the destination FTP/TFTP server. For example, to set the IP address of 10.41.208.205, enter 10*41*208*205 [separate with an asterisk (*)].



After entering an IP address, press  or **OK** soft key.

STEP 17: The display goes back to the **Backup/Restore** screen. Select **1 Data Backup**.

- Select an item by either of the following operations.
- Highlight an item by using , and then press ,  or **OK** soft key.
 - Press **1** key.

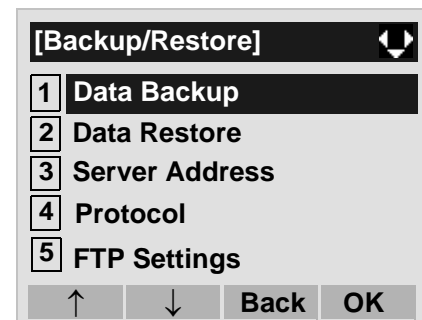

STEP 18: The default file name will be displayed as follows:

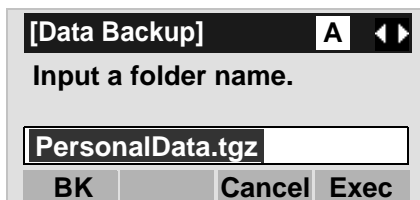

Note: Do not change the extension of the backup file. The setting data of the telephone can only be backed up as a.tgz file.

Note: When changing the default file name, press BK soft key once to delete the default file name and then enter a new file name by using the digits keys.

Note: For details on character entry method, see [HOW TO INPUT CHARACTERS](#) in chapter 4 Basic Operation.

Note: A maximum of 20 characters ("0-9", "A-Z", "a-z", "*", "#", ".", "-" or "_") can be entered as a file name.

Note: To delete an entered character, press BK soft key.

STEP 19: Press  or **Exec** soft key to start the data backup. While making a backup copy, the LCD displays "Uploading..." first and then "Saving..."

Note: Be sure not to turn OFF the DT700 Series while "Saving..." is displayed on the LCD.

STEP 20: After the data backup is complete, the display changes as follows:

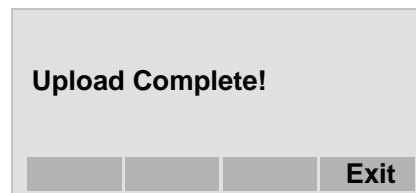

The display goes back to the **Backup/Restore** screen by **Exit** soft key.

Note: When the data backup ends in failure, "Upload Failed!" is displayed on the LCD. Check to see the following and then make a retry.

Check Points	Actions
A different file name is specified between DT700 Series and FTP/TFTP server.	Set the same file name from both DT700 Series and FTP/TFTP server.
Incorrect IP address of FTP/TFTP server has been entered from the telephone.	Set the proper IP address of FTP/TFTP server.
The power to FTP/TFTP server or network equipment is OFF.	Turn on the power.
LAN cable is disconnected.	Reconnect the cable securely.

• **TO RESTORE PERSONAL SETTINGS**

DT730/DT710

DT730/DT710 Series user can restore the personal settings of DT Series. To download the backup file to the telephone, the DT Series needs to be connected to the network that has FTP (TFTP server).

Note: For details on the FTP/TFTP service, contact the System Administrator.

Before starting the download, an IP Address of the FTP/TFTP Server must be entered from DT Series.

STEP 1: Set up the FTP/TFTP server.



<FTP server>

Put the backup file you want to restore into the designated directory (for Windows IIS, the default is "C:\InetPub\ftproot) of the FTP server.

<TFTP server>



Put the backup file you want to restore into a desired directory of TFTP server and then specify it as the directory for downloading.

STEP 2: Select **5 Setting** (DT730) / **2 Setting** (DT710) on the **Menu** screen.

- Select an item by either of the following operations.
- Highlight an item by using , and then press , or **OK** soft key.
 - Press **5** key (DT730) / **2** key (DT710)



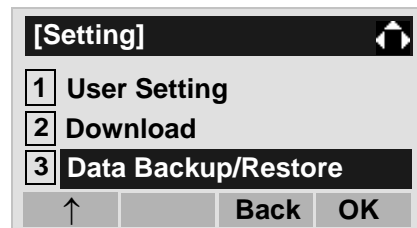

STEP 3: Select **3 Data Backup/Restore**.

- Select an item by either of the following operations.
- Highlight an item by using , and then press , or **OK** soft key.
 - Press **3** key.



STEP 4: Select **4 Protocol**.

- Select an item by either of the following operations.
- Highlight an item by using , and then press , or **OK** soft key.
 - Press **4** key.

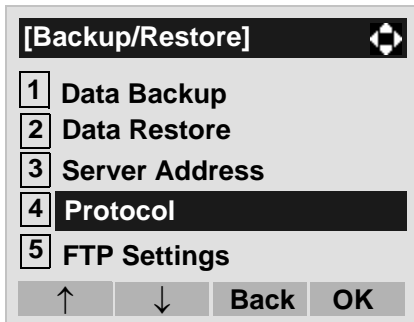

STEP 5: Select a protocol used by the server which stores the backup file.

Select an item by either of the following operations.

- Highlight an item by using , and then press or **OK** soft key.
- Press **(1)** or **(2)** key, and then press or **OK** soft key.

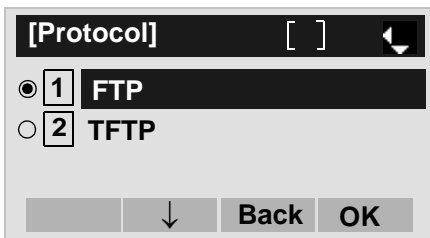

STEP 6: The display goes back to the **Backup/Restore** screen.

When **(1) FTP** is selected here, go to the next Step (STEP 7).

When **(2) TFTP** is selected here, go to the next STEP 15.

STEP 7: Select **(5) FTP Settings**.

Select an item by either of the following operations.

- Highlight an item by using , and then press , or **OK** soft key.
- Press **(5)** key.

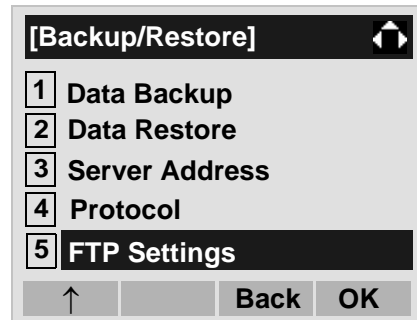

STEP 8: Select **(1) User ID**.

Select an item by either of the following operations.

- Highlight an item by using , and then press , or **OK** soft key.
- Press **(1)** key.

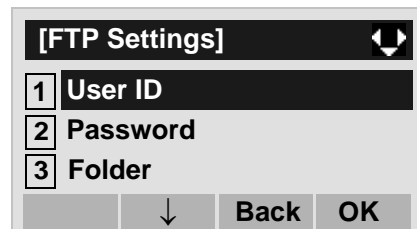

STEP 9: Enter a User ID by using digit keys, then press or **OK** soft key.

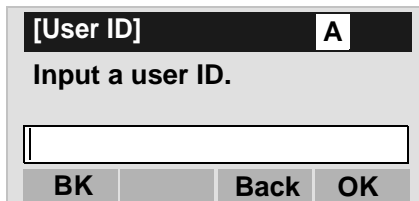

Note: For details on character entry method, see [HOW TO INPUT CHARACTERS](#) in chapter 4 Basic Operation.

STEP 10: The display goes back to the **FTP Settings** screen. Select **2 Password**.

- Select an item by either of the following operations.
- Highlight an item by using , and then press , or **OK** soft key.
 - Press **2** key.

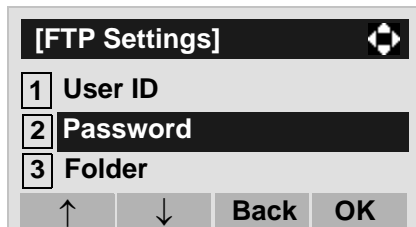

STEP 11: Enter a password by using digit keys, then press or **OK** soft key.

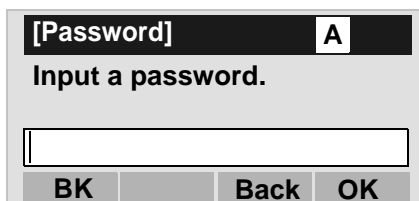

Note: For details on character entry method, see [HOW TO INPUT CHARACTERS](#) in chapter 4 Basic Operation.

STEP 12: The display goes back to the **FTP Settings** screen. Select **3 Folder**.

- Select an item by either of the following operations.
- Highlight an item by using , and then press , or **OK** soft key.
 - Press **3** key.

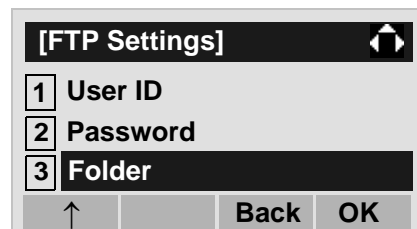

STEP 13: Enter the directory where the backup file is stored and then press or **OK** soft key.

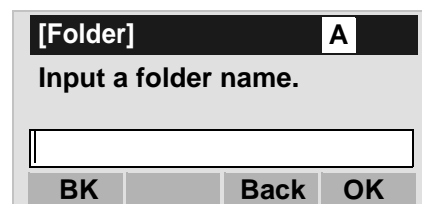

Note: For details on character entry method, see [HOW TO INPUT CHARACTERS](#) in chapter 4 Basic Operation.

STEP 14: The display goes back to the **FTP Settings** screen. Press or **Back** soft key to display

the **Backup/Restore** screen.

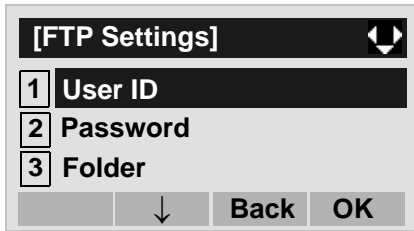

STEP 15: Select **3 Server Address**.

- Select an item by either of the following operations.
- Highlight an item by using , and then press , or **OK** soft key.
 - Press **3** key.

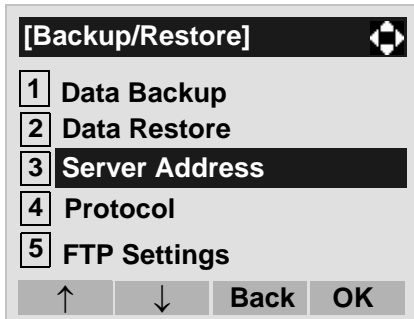

STEP 16: Enter an IP address of the FTP/TFTP server which stores the backup file. For example, to set the IP address of 10.41.208.205, enter 10*41*208*205 [separate with an asterisk (*)].

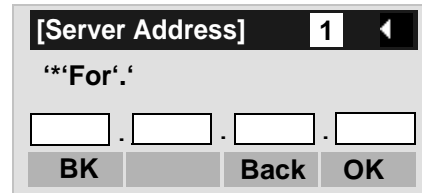

After entering an IP address, press or **OK** soft key.

STEP 17: The display goes back to the **Backup/Restore** screen. Select **2 Data Restore**.

- Select an item by either of the following operations.
- Highlight an item by using , and then press , or **OK** soft key.
 - Press **2** key.

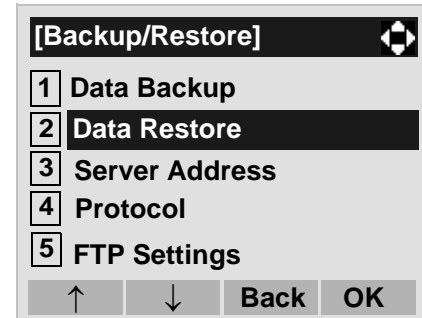

STEP 18: The default file name will be displayed as follows:



Note: Do not change the extension (.tgz) of the backup file. If the extension is changed, the file cannot be restored properly.

Note: When changing the default file name, press BK soft key once to delete the default file name and then enter a new file name by using the digits keys.

Note: For details on character entry method, see [HOW TO INPUT CHARACTERS](#) in chapter 4 Basic Operation.

Note: A maximum of 20 characters ("0-9", "A-Z", "a-z", "*", "#", ".", "-" or "_") can be entered as a file name.

Note: To delete an entered character, press BK soft key.

STEP 19: Press  or **Exec** soft key to start restoring the backup data to the telephone. While downloading the backup data, the LCD displays "Downloading..." first and then "Saving..."

Note: Be sure not to turn OFF the DT700 Series while "Saving..." is displayed on the LCD.

STEP 20: After the downloading process is complete, the display changes as follows:

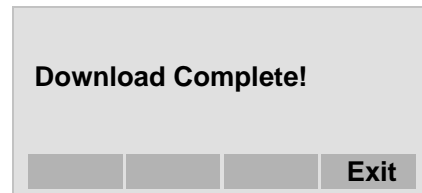

The display goes back to the **Backup/Restore** screen by **Exit** soft key.

Note: When the downloading process ends in failure, "Download Failed!" is displayed on the LCD. Check to see the following and then make a retry.

Check Points	Actions
Download file is not placed in the specified directory.	Place the download file in the specified directory.
A different file name is specified between DT700 Series and FTP/TFTP server.	Set the same file name from both DT700 Series and FTP/TFTP server.
Incorrect IP address of FTP/TFTP server has been entered from the telephone.	Set the proper IP address of FTP/TFTP server.
The power to FTP/TFTP server or network equipment is OFF.	Turn on the power.
LAN cable is disconnected.	Reconnect the cable securely.



SETUP WITH MENU KEY FOR DT300 SERIES

• TO CHANGE RINGER TONE VOLUME DT330

The procedure below shows how to change the volume of ringer tone.

STEP 1: While indicating the current time on LCD, press  key to open the **Menu** screen. Then, select **3 Settings**.

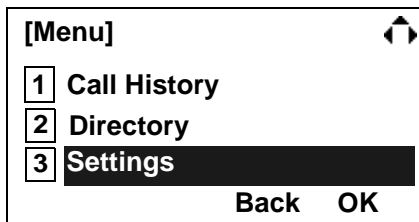

Select an item by either of the following operations.

- Highlight an item by using , and then press ,  or **OK** soft key.
- Press **3** key.





STEP 2: Select **1 Ring Volume**.

Select an item by either of the following operations.

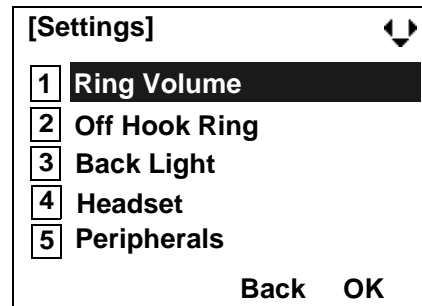
- Highlight an item by using , and then press ,  or **OK** soft key.
- Press **1** key.



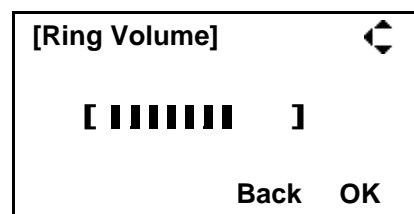
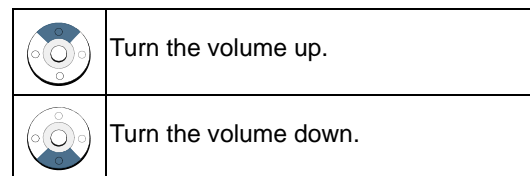

STEP 3: Ring Volume can be set in 13 levels (0 - 12). Adjust the ringer tone volume by using  key and then press  or **OK** soft key.



• **TO ENABLE/DISABLE OFF-HOOK RINGING DT330**



The procedure below shows how to

STEP 1: While indicating the current time on LCD, press **Menu** key to open the **Menu** screen. Then, select **3 Settings**.

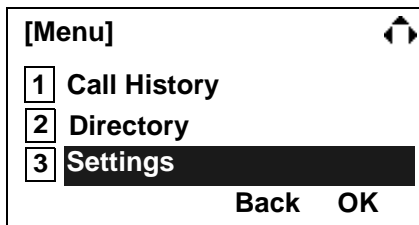
- Select an item by either of the following operations.
- Highlight an item by using , and then press , or **OK** soft key.
 - Press **3** key.



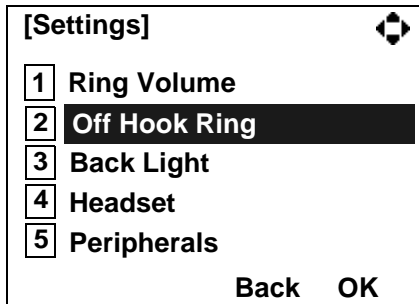

STEP 2: Select **2 Off Hook Ring**.

- Select an item by either of the following operations.
- Highlight an item by using , and then press , or **OK** soft key.
 - Press **2** key.



STEP 3: To disable/enable the off-hook ringing, select **1 Disable** or **2 Enable**.

Select an item by either of the following operations.

- Highlight an item by using , and then press , or **OK** soft key.
- Press **1** or **2** key, and then press  or **OK** soft key.

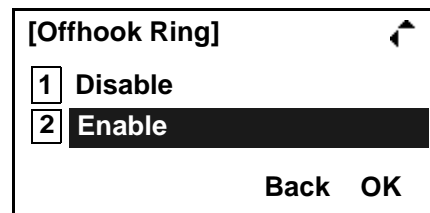

Note: Default setting is **2 Enable**.

Note: The enabled item is highlighted.



• **TO ENABLE/DISABLE BACKLIGHT**

DT330

The following explains how to enable/disable the backlights of LCD and digit keys.



The backlights illuminate (for approximately 10 seconds) when you press any key or lift the handset.

STEP 1: While indicating the current time on LCD, press **Menu** key to open the **Menu** screen. Then, select **3 Settings**.

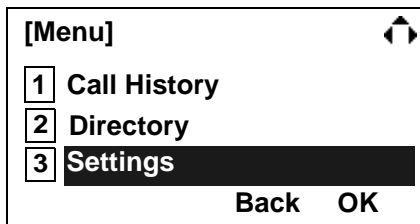
- Select an item by either of the following operations.
- Highlight an item by using , and then press ,  or **OK** soft key.
 - Press **3** key.



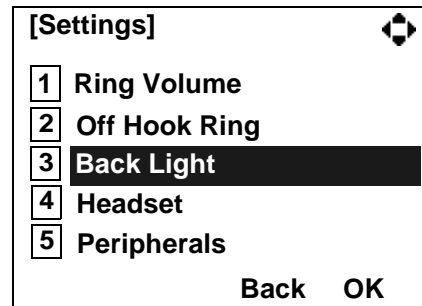

STEP 2: Select **3 Back Light**.

- Select an item by either of the following operations.
- Highlight an item by using , and then press ,  or **OK** soft key.
 - Press **3** key.



STEP 3: Make a selection from the following list.

- Select an item by either of the following operations.
- Highlight an item by using , and then press  or **OK** soft key.
 - Press **1** or **2** key, and then press  or **OK** soft key.

Menu Item	Meaning
1 Disable	Backlights of LCD and digit keys are disabled.
2 Enable	Backlights of LCD and digit keys are enabled.

Note: Default setting is **2 Enable**.

Note: The enabled item is highlighted.

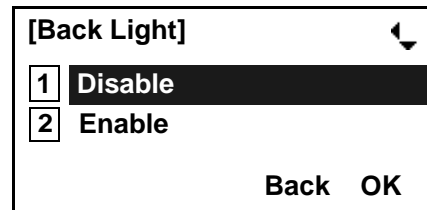



STEP 4: After Making a selection, press  or **OK** soft key.

• **TO SET RINGING OF HEADSET** **DT330**



The procedure below shows how to enable/disable the ringing of headset.

STEP 1: While indicating the current time on LCD, press **Menu** key to open the **Menu** screen. Then, select **3 Settings**.

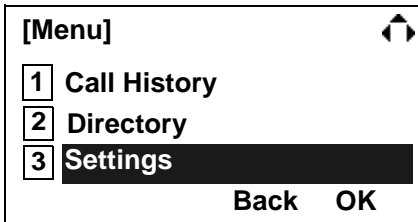
- Select an item by either of the following operations.
- Highlight an item by using , and then press , or **OK** soft key.
 - Press **3** key.



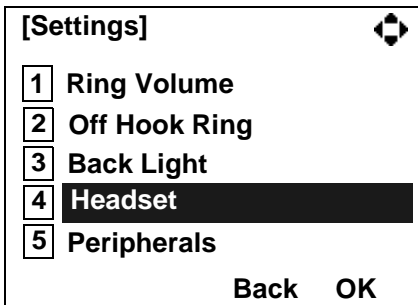

STEP 2: Select **4 Headset**.

- Select an item by either of the following operations.
- Highlight an item by using , and then press , or **OK** soft key.
 - Press **4** key.



STEP 3: To disable/enable the ringing of headset, select **1 Disable** or **2 Enable**.

- Select an item by either of the following operations.
- Highlight an item by using , and then press , or **OK** soft key.
 - Press **1** or **2** key, and then press , or **OK** soft key.

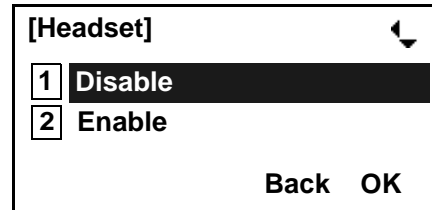

Note: Default setting is **1 Disable**.

Note: The enabled item is highlighted.

4. BASIC OPERATION

This chapter describes the following basic operation of DT Series.

- TO LOGIN
- TO LOGOUT
- TO MAKE AN EXTERNAL CALL
- TO MAKE AN INTERNAL CALL
- TO ANSWER AN EXTERNAL CALL
- TO ANSWER AN INTERNAL CALL
- MULTILINE APPEARANCE
- TO HOLD A CALL
- TO PLACE A CALL ON EXCLUSIVE HOLD
- TO TRANSFER A CALL
- HOW TO INPUT CHARACTERS
- SECURITY MODE
- EMERGENCY CALL

TO LOGIN **DT730/710**

Note: This feature is only available for DT700 Series.

STEP 1: When login mode is activated, the telephone prompts for Login ID and Password.

```
Login ID : -
Password :
Cancel    Back    Set    OK
```

STEP 2: Enter login code and press **Set** soft key.
(Station number is used as the Login code.)

```
Login ID : 2000
Password :
Cancel    Back    Set    OK
```

STEP 3: Enter the password and press **OK** Soft key.

```
Login ID : 2000
Password : *****
Cancel    Back    Set    OK
```

STEP 4: If the login code is accepted, display changes to normal idle status.

```
7:25 AM MON 12 JUL 2010
MIC    DND    >>>
```

TO LOGOUT **DT730/710**

STEP 1: Press the preassigned **Logout** Feature Key on the terminal.

Note: This feature is only available for DT700 Series.

Note: The soft key location is an example.

Note: Logout key is assigned by data setting at the ECP (Enterprise Communication Platform).

```
7:25 AM MON 12 JUL 2010
MIC    DND    >>>
```

STEP 2: "LOGOUT?" is displayed on the LCD of the terminal.

```
LOGOUT?
7:25 AM MON 12 JUL 2010
L-OUT  >>>
```

STEP 3: Press the **Logout** Feature Key on the terminal again.

TO MAKE AN EXTERNAL CALL

DT730/710 DT330/310

When dialed telephone number is registered in Personal Directory, the corresponding name information will be displayed on LCD of DT730 Series while you are hearing a ringback tone or are engaged in a conversation. According to the initial settings, the display may differ from the following examples. For more information, contact the system administrator.

Note: Personal Directory Name Display function is available only for DT730 Series.

Note: This section describes the Normal Dial Mode. Regarding the other mode, see [TO ORIGINATE A CALL USING SELECTIVE DIALING \(DYNAMIC DIAL PAD, PRESET DIAL\)](#) in Chapter 5.

STEP 1: Lift handset or press  key, receive dial tone.



STEP 2: Dial the Central Office access code, e.g. 9.



STEP 3: Dial desired telephone number.

(while hearing a ringback tone)



STEP 4: Use handset or MIC to start a conversation.

Display indicates:

(while in a conversation)

- When dialed number is registered in Personal Directory

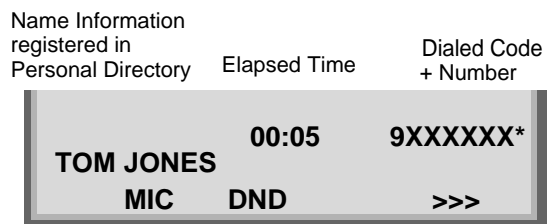

Note: In the above case, a maximum of eight digits of the number (including “*”) can be displayed. If the dialed number exceeds eight digits, “the first seven digits of the number + *” or “the last seven digits of the number + *” are displayed. For more information, please contact the system administrator.

- When dialed number is not registered in Personal Directory



Note: My Line is an actual line that is directly associated with station number of the telephone. You can make/answer a call via this line. Usually, My line is seized automatically only by lifting the handset or pressing the Speaker key.

Dialed Station Number

31314
1:25 PM MON 12 JUL 2010
MIC DND >>>

Note: My Line is an actual line that is directly associated with station number of the telephone. You can make/answer a call via this line. Usually, My line is seized automatically only by lifting the handset or pressing the Speaker key.

TO ANSWER AN EXTERNAL CALL

DT730/710 DT330/310

When calling party telephone number is registered in Personal Directory, the corresponding name information will be displayed on LCD of DT730 Series while you are hearing a ringing tone or are engaged in a conversation. According to the initial settings, the display may differ from the above example. For more information, contact the system administrator.

Note: Personal Directory Name Display function is available only for DT730 Series.

STEP 1: You hear the ringing tone. Call indicator flashes red while hearing ring tone.

- When calling party telephone number is registered in Personal Directory

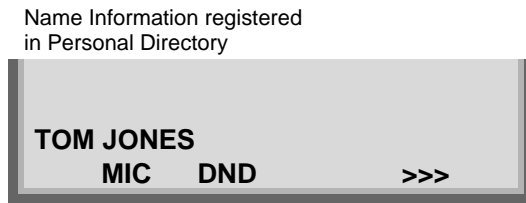

- When calling party telephone number is not registered in Personal Directory

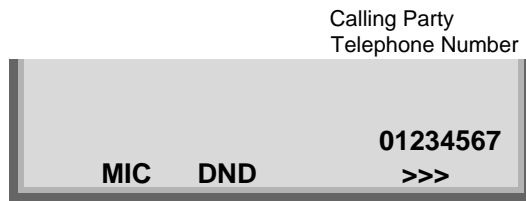

- When caller ID is not received

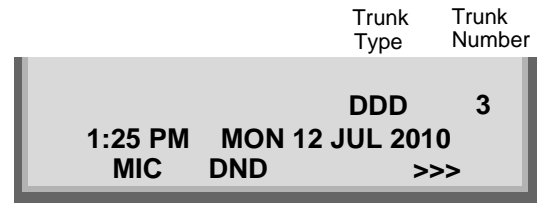

STEP 2: Press  key or touch the appropriate Line Key.

STEP 3: Lift the handset to answer the call.

(while in a conversation)

- When calling party telephone number is registered in Personal Directory

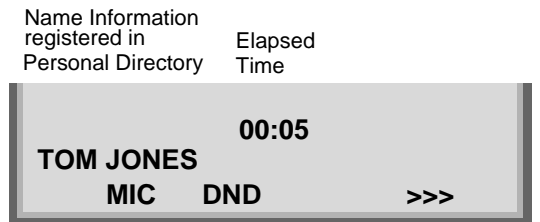

- When calling party telephone number is not registered in Personal Directory

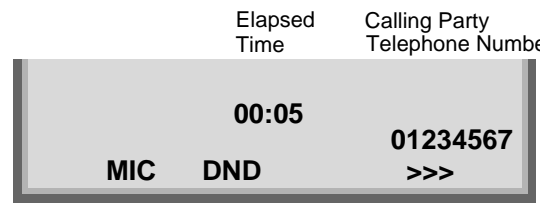

- When caller ID is not received

	Elapsed Time	Trunk Type	Trunk Number
	00:05	DDD	3
1:25 PM	MON 12 JUL 2010		
MIC	DND	>>>	

Note: When an incoming call is terminated to My Line of the telephone, you can usually answer the call only by lifting the handset or pressing the Speaker Key.

TO ANSWER AN INTERNAL CALL

The following procedure explains how to answer an internal call routed to My Line of the telephone.

When calling station number is registered in Personal Directory, the corresponding name information will be displayed on LCD of DT730 Series while you are hearing a ringing tone or are engaged in a conversation. According to the initial settings, the display may differ from the above example. For more information, contact the system administrator.

Note: Personal Directory Name Display function is available only for DT730 Series.

STEP 1: You hear the ringing tone. Call indicator flashes red while hearing ring tone.

- When calling station number is registered in Personal Directory

Name Information registered in Personal Directory	Calling Station Number
MARY HARRIS MIC	31314 >>>

- When calling station number is not registered in Personal Directory

	Calling Station Number
1:25 PM MON 12 JUL 2010 MIC	31314 >>>

STEP 2: Press **Answer** key or touch the appropriate Line Key.

STEP 3: Lift the handset to answer the call.

(while in a conversation)

- When calling station number is registered in Personal Directory

Name Information registered in Personal Directory	Calling Station Number
MARY HARRIS MIC	31314 >>>

- When calling station number is not registered in Personal Directory

	Calling Station Number
1:25 PM MON 12 JUL 2010 MIC	31314 >>>

Note: When an incoming call is terminated to My Line of the telephone, you can usually answer the call only by lifting the handset or pressing the Speaker Key.

MULTILINE APPEARANCE

DT730/710 **DT330/310**

To Originate a Call

- STEP 1: Press the **MULTILINE APPEARANCE** feature key.
- STEP 2: Lift handset or press  key. Dial the Central Office access code (i.e.9 (US), 0 (Aust)).
- STEP 3: Dial the desired number.

To Answer a Call

- STEP 1: Press the **MULTILINE APPEARANCE** feature key (ringing and flashing LED alert user to incoming call).
- STEP 2: Lift handset or press  key.
- STEP 3: Speak with incoming party.

TO HOLD A CALL **DT730/710** **DT330/310**

- STEP 1: Press  key. Held line wink flashes.

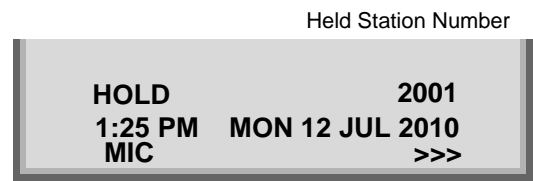

Note: If held line appears on other DT Series stations, the associated LED flashes red slowly.

To Retrieve

- STEP 1: Lift handset or press  key.
- STEP 2: Press held line. Use handset to converse.

Note: Any station with this line appearance can retrieve the call.

If unanswered

- STEP 1: After preprogrammed time, Automatic Recall is initiated.
- STEP 2: Visual and audible signal (rapid flash and ring burst) is sent to station that placed call on hold.

Note: *Hold* shows as a flashing green LED on your phone. The same line on other phones shows as a flashing red LED. **Recall** shows as a flashing green LED on your phone and flashing red LED on other phones with the same line.

STEP 4: If transferring party hangs up, that station's number appears in the center of recipient's display.

Transferring station

TRANSFER 2000 DDD 3
1:25 PM MON 12 JUL 2010
MIC >>>

HOW TO INPUT CHARACTERS DT730

This section explains how to enter characters on the text input screen such as Name or User ID, etc.

- **Character Entry Mode**

When entering characters from the telephone set, the following three modes are available: uppercase alphabetic character, lowercase alphabetic character and numeric character. The character entry mode can be changed by pressing ***** key (alphabetic/numeric) or from the Sub Menu screen (uppercase/lowercase).

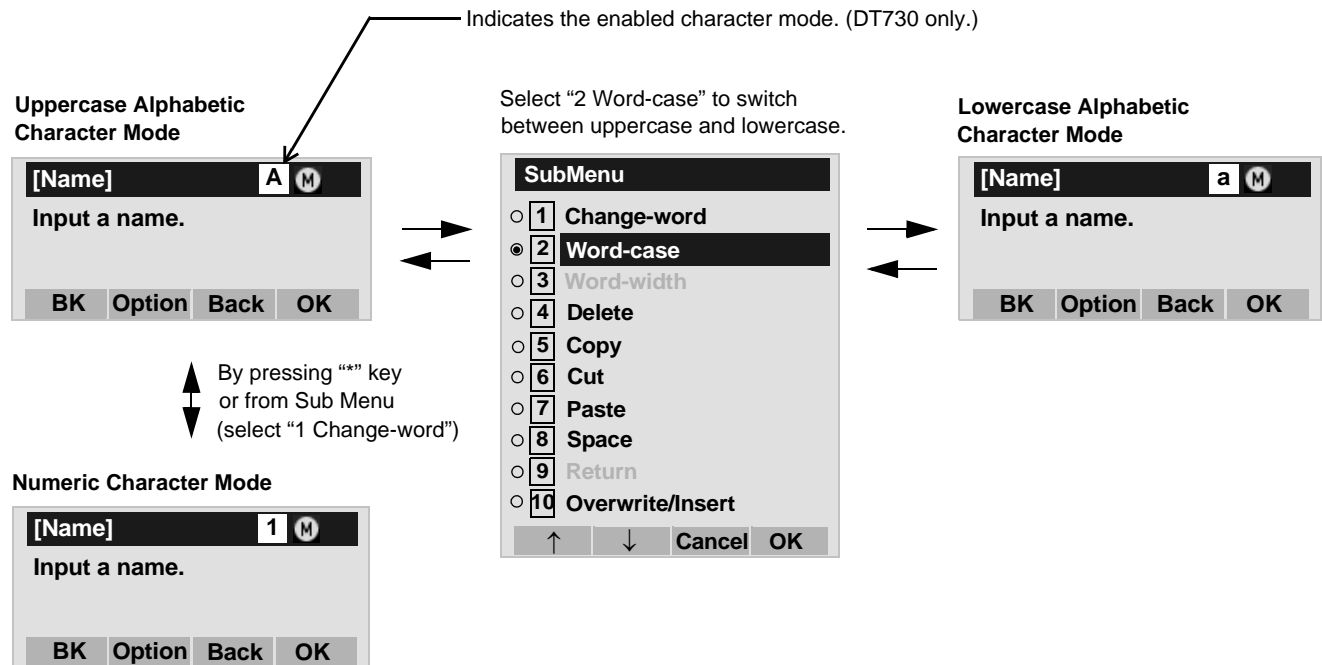

The enabled entry mode is indicated in the top portion of the LCD screen (DT730 only).

To display the Sub Menu screen, press  key or **Option** Soft Key while the text input screen is displayed. Also, the following operations are available from the Sub Menu screen.

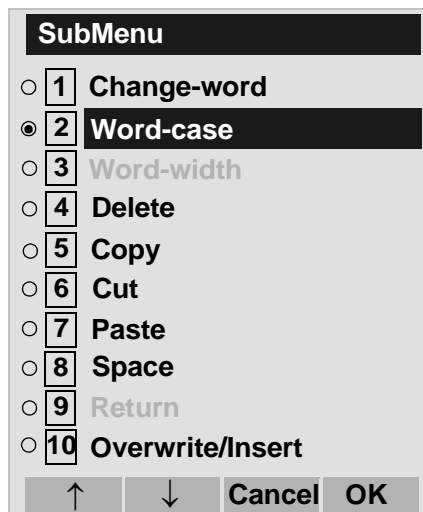

Sub Menu Items	Descriptions
Change-word	Change character entry mode between uppercase alphabetic, lowercase alphabetic and numeric character.
Word-case	Switch between uppercase and lowercase.
Word-width	Not used.
Delete	Delete a single character.
Copy	Copy the specified characters.
Cut	Cut the specified characters.
Paste	Paste the specified characters.
Space	Enter a space.
Return	Start a new line.
Overwrite/Insert	Write over existing characters.



- **Character Code List**

<Character Code For English (1/2)>

DIGIT KEY	CASE SHIFT	1st	2nd	3rd	4th	5th	6th	7th	8th	9th	10th	11th	12th	13th
①	A	.	,	\	1	?	!	“	@	:	;			
	a							Note						
②	A	A	B	C	2									
	a	a	b	c	2									
③	A	D	E	F	3									
	a	d	e	f	3									
④	A	G	H	I	4									
	a	g	h	i	4									
⑤	A	J	K	L	5									
	a	j	k	l	5									
⑥	A	M	N	O	6									
	a	m	n	o	6									
⑦	A	P	Q	R	S	7								
	a	p	q	r	s	7								
⑧	A	T	U	V	8									
	a	t	u	v	8									
⑨	A	W	X	Y	Z	9								
	a	w	x	y	z	9								
⑩	A	[SP]	0											
	a													

Note: Not available from Firmware version 3.0.0.0 and later

<Character Code For English (2/2)>

		1st	2nd	3rd	4th	5th	6th	7th	8th	9th	10th	
 Note1	A	*	#	.	/	:	~	!	@	\$	%	
	a											
			11th	12th	13th	14th	15th	16th	17th	18th	19th	20th
	A	^	&	()	'	?	“	–	+	-	
	a							Note2				
			21th	22th	23th	24th	25th	26th	27th	28th	29th	30th
A	=	[]	{	}	<	>	,	;	\		
a												
 Note1	Used as a case shift key. Shifts the characters between alphabetic and numeric.											

Note1:  and  key is the same for Russian, Turkish and other Languages.

Note2: Not available from Firmware version 3.0.0.0 and later

<Character Code For Russian>

DIGIT KEY	CASE SHIFT	1st	2nd	3rd	4th	5th	6th	7th	8th	9th	10th	11th	12th	13th	14th	15th
①	A	.	,	:	!	?	+	-	%	&	/	()	=	¿	¡
	a															
②	A	А	Б	В	Г											
	a	а	б	в	г											
③	A	Д	Е	Ё	Ж	З										
	a	д	е	ё	ж	з										
④	A	И	Й	К	Л											
	a	и	й	к	л											
⑤	A	М	Н	О	П											
	a	м	н	о	п											
⑥	A	Р	С	Т	У											
	a	р	с	т	у											
⑦	A	Ф	Х	Ц	Ч											
	a	ф	х	ц	ч											
⑧	A	Ш	Щ	Ъ	Ы	Ь										
	a	ш	щ	ъ	ы	ь										
⑨	A	Э	Ю	Я												
	a	э	ю	я												
⑩	A	[SP]														
	a															

Note: ① and * key is the same for English. Refer to the <Character Code For English (2/2)>.

<Character Code For Turkish>

DIGIT KEY	CASE SHIFT	1st	2nd	3rd	4th	5th	6th	7th	8th	9th	10th	11th	12th	13th	14th	15th
①	A	.	,	:	!	?	+	-	%	&	/	()	=	ı	i
	a															
②	A	A	B	C	Ç											
	a	a	b	c	ç											
③	A	D	E	F												
	a	d	e	f												
④	A	G	Ğ	H	I	i										
	a	g	ğ	h	ı	ı										
⑤	A	J	K	L												
	a	j	k	l												
⑥	A	M	N	O	Ö											
	a	m	n	o	ö											
⑦	A	P	R	S	Ş											
	a	p	r	s	ş											
⑧	A	T	U	Ü	V											
	a	t	u	ü	v											
⑨	A	Y	Z													
	a	y	z													
⑩	A	[SP]														
	a															

Note: ① and ② key is the same for English. Refer to the <Character Code For English (2/2)>.

<Character Code For Other Languages>

DIGIT KEY	CASE SHIFT	1st	2nd	3rd	4th	5th	6th	7th	8th	9th	10th	11th	12th	13th	14th	15th
①	A	.	,	:	!	?	+	-	%	&	/	()	=	¿	i
	a															
②	A	A	B	C	À	Á	Â	Ã	Ä	Å	Æ	Ç				
	a	a	b	c	à	á	â	ã	ä	å	æ	ç				
③	A	D	E	F	È	É	Ê	Ë								
	a	d	e	f	è	é	ê	ë								
④	A	G	H	I	Ì	Í	Î	Ï								
	a	g	h	i	ì	í	î	ï								
⑤	A	J	K	L												
	a	j	k	l												
⑥	A	M	N	O	Ñ	Ò	Ó	Ô	Õ	Ö	Œ	Ø				
	a	m	n	o	ñ	ò	ó	ô	õ	ö	œ	ø				
⑦	A	P	Q	R	S	ß										
	a	p	q	r	s	ß										
⑧	A	T	U	V	Û	Ü	Û	Ü								
	a	t	u	v	ù	ú	û	ü								
⑨	A	W	X	Y	Z											
	a	w	x	y	z											
⑩	A	[SP]														
	a															

Note: # and * key is the same for English. Refer to the <Character Code For English (2/2)>.

<Number Code>

DIGIT KEY	CASE SHIFT	1st	2nd	3rd	4th	5th	6th	7th	8th	9th	10th	11th	12th	13th	14th	15th
①	☐1	1														
②	☐1	2														
③	☐1	3														
④	☐1	4														
⑤	☐1	5														
⑥	☐1	6														
⑦	☐1	7														
⑧	☐1	8														
⑨	☐1	9														
⑩	☐1	0														
☐#	☐1	*	#	.	@	/	()	,	-	_	:	'	~	&	\
☐*	☐1	Used as a case shift key. Shifts the characters between alphabetic and numeric.														

Note: When entering password, "0-9", "*" and "#" are available.

"#" is entered by pressing ☐# key.

"*" is entered by pressing ☐* key.

- **Character Entry Method**

As an example of character entry method, the following shows how to enter “Ken Kobus”.

STEP 1: Press **5** key twice to enter “K”.

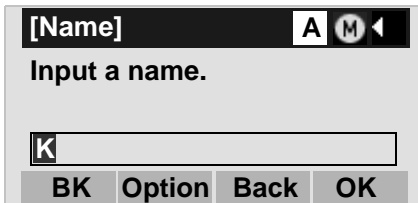

STEP 2: Press **Menu** key or **Option** soft key to display Sub Menu screen, and then select **2 Word-case** to switch the text input mode from uppercase to lowercase.



STEP 3: Press **OK** soft key on the Sub Menu to go back to text input screen.

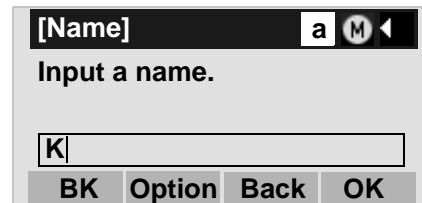

STEP 4: Enter “en” by using digit keys.

Press **3** key twice to enter “e”.

Press **6** key twice to enter “n”.



STEP 5: Press **0** key once to enter a space.

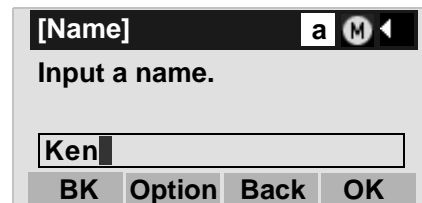

STEP 6: Press **Menu** key or **Option** soft key to display SubMenu screen, and then select **2 Word-case** to switch the text input mode from lowercase to uppercase.

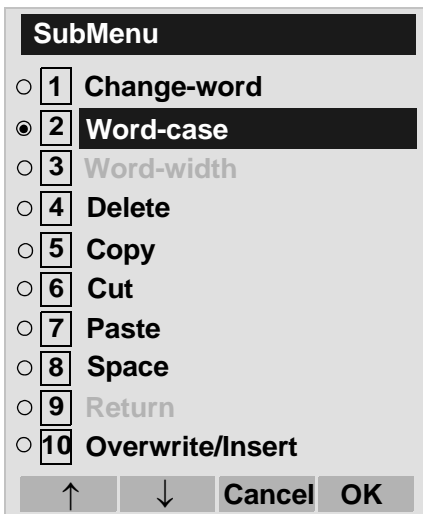

STEP 7: Press **Menu** or **OK** soft key on the Sub Menu to go back to text input screen.

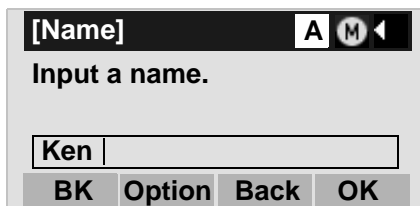

STEP 8: Press **5** key twice to enter "K".

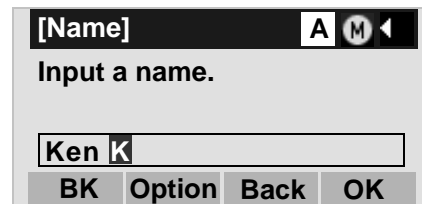

STEP 9: Press **Menu** key or **Option** soft key to display SubMenu screen, and then select **2 Word-case** to switch the text input mode from lowercase to uppercase.



STEP 10: Press  or **OK** soft key on the Sub Menu to go back to text input screen.

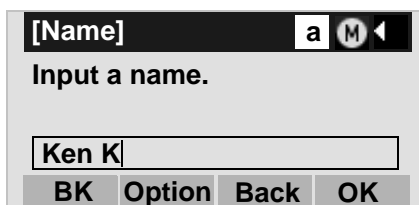

STEP 11: Enter "obus" by using digit keys.

Press **6** key three times to enter "o".

Press **2** key twice to enter "b".

Press **8** key twice to enter "u".

Press **7** key four times to enter "s".

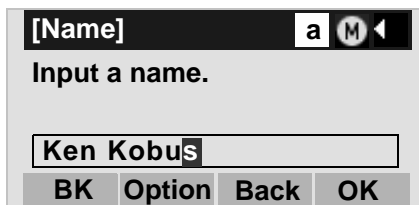



STEP 12: Press  or **OK** soft key.

- **To Overwrite Characters**

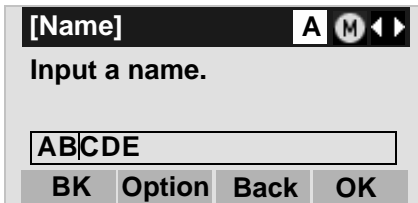
STEP 1: Place the cursor at the left of the characters to be overwritten.



STEP 2: Press  key or **Option** soft key.

STEP 3: On the following Sub Menu screen, select **10 Overwrite/Insert** and then press ,  or **OK** soft key.

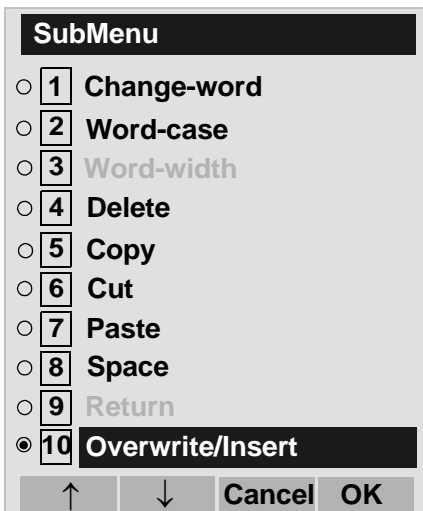

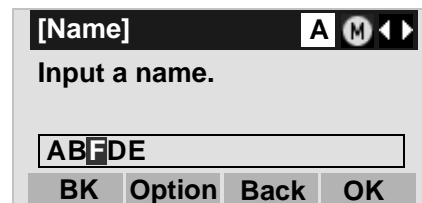

STEP 4: Enter new words over existing characters. In this example, "F" is entered.



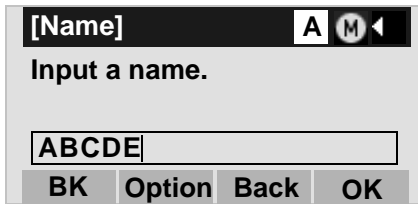

• **To Copy and Paste Characters**

STEP 1: While characters which you want to copy are displayed, press  key or **Option** soft key.

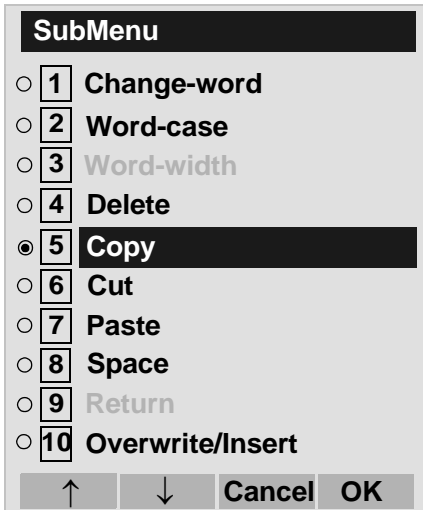

STEP 2: On the Sub Menu screen, press  or **OK** soft key while **5 Copy** is highlighted, or press **5** key.



STEP 3: Place the cursor at the starting point of the target characters by using  and then press **Start** soft key.

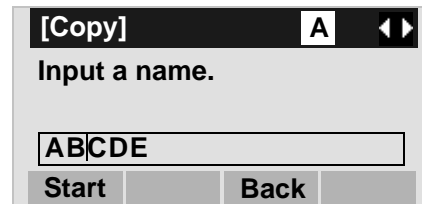

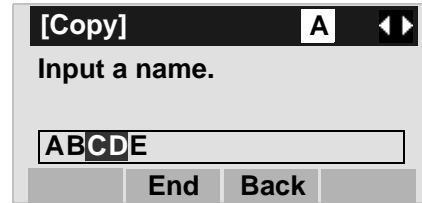

STEP 4: Place the cursor at the end point of the target characters  and then press **End** soft key.

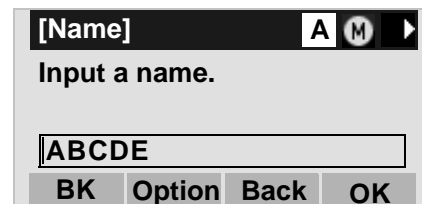

STEP 5: Place the cursor at position where you want to paste the copied characters and then press  key or **Option** soft key.



STEP 6: On the Sub Menu screen, select **7 Paste** and then press ,  or **OK** soft key. (or press **7** key.)

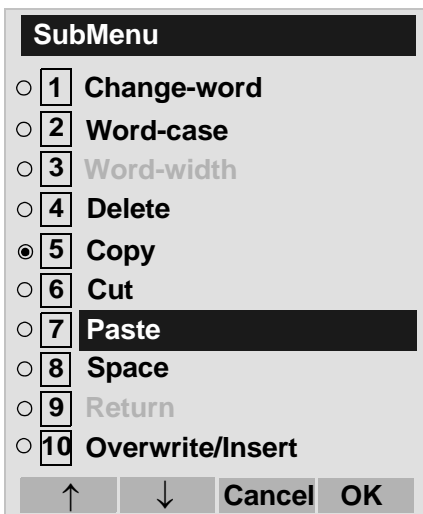

STEP 7: The copied characters “CD” are inserted as follows:

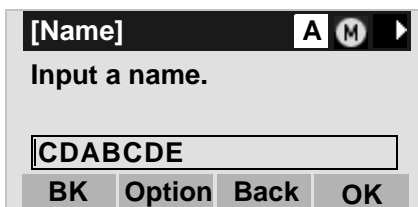

SECURITY MODE **DT730**

DT730 Series has the **Security** key which prevents information leakage from terminal. While the terminal is locked, Security Lamp lights up.



Note: When the system administrator invalidates the security mode, this function cannot be used. For details of the security mode, contact the system administrator.

Note: While the telephone is locked,  key becomes disabled. Also, any features provided by the telephony server, such as call origination or call answering, cannot be performed. (The Incoming call cannot be picked up though "Ringing" or "Voice call" are possible.) It is necessary to release the security mode to respond.

Note: To make a call of VOICE CALL is available toward a called party in the Security mode. When a called party activates the Security mode with leaving its MIC to ON, the called party can converse with a calling party though terminal operation is restricted.

Note: Even when the telephone is reset for any reason (such as power-off, etc.) while the telephone is placed in security mode, the lock is not released.

• TO LOCK THE TELEPHONE

Before placing DT700 Series in Security mode, you can set a password. For details on the password setting, see [TO CHANGE PASSWORD](#) in chapter 3 Terminal Setup.

STEP 1: Press **Security** key on DT730 Series. The following message is displayed on LCD.

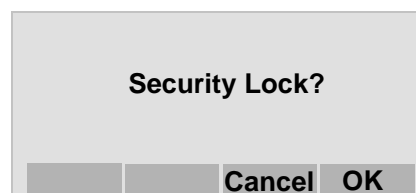

STEP 2: Press  or **OK** soft key to place DT700 Series in Security mode.

STEP 3: When DT730 Series is placed in Security mode, Security Lamp lights red and the screen saver will be activated.

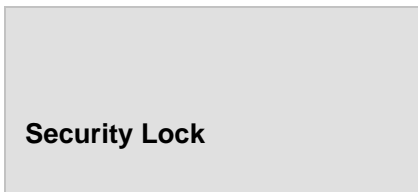



• TO UNLOCK THE TELEPHONE

STEP 1: Display the Password Entry screen by either of the following operations.

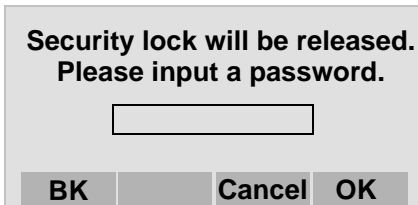
- Press any key while the screen saver is activated.
- Press **Security** key while the screen saver is activated.



STEP 2: Enter the password and then press  or **OK** soft key. Security Lamp is extinguished and Security Mode is canceled.

Note: When the password entry ends in failure, the following error message is issued. In that case, press  or **OK** soft key and then retry.

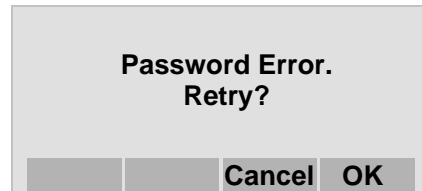

Note: After a third attempt (if incorrect password entered three times), the following error message is issued. Press  or **OK** soft key. The telephone locks up, and any key operation will be disabled for 10 minutes. After 10 minutes, make a retry.

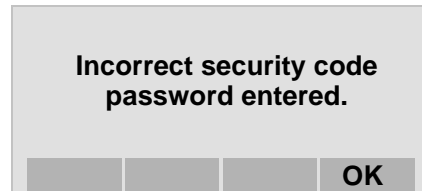

EMERGENCY CALL **DT730**

You can make a call to a predetermined emergency telephone number while the telephone is locked (in Security mode). This function is available on the telephone with Security key.

Note: You can make an emergency call to only the predetermined number. For details on the setting of the emergency number, contact the system administrator.

STEP 1: Lift the handset while the telephone is locked (the screen saver is activated).

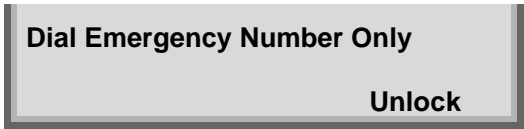

Note: Emergency call cannot be made with **Speaker** key.

Note: When pressing Unlock soft key, the telephone prompts for the Security mode cancellation password.

STEP 2: Dial an emergency telephone number by pressing digit keys(0-9, *, #).

Note: Emergency telephone number needs to be set in advance. For the setting of the emergency telephone numbers, contact the system administrator.

Note: You can make a call to only the predetermined number. When telephone numbers other than the predetermined emergency number are dialed, the following message appears (after a few seconds, the display goes back to "Dial Emergency Number Only" screen).

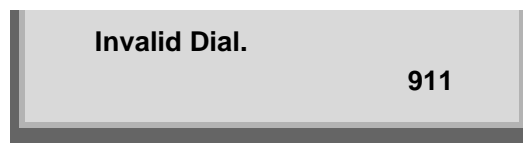

STEP 3: After a conversation, replace the handset. The LCD turns to time display. (Security mode is released.)

This page is for your notes.

5. FEATURE OPERATION

TO ORIGINATE A CALL USING SELECTIVE DIALING (DYNAMIC DIAL PAD, PRESET DIAL)

Dynamic Dial Pad **DT730/710** **DT330/310**

STEP 1: Enter desired telephone number (Digit Keys 0-9, *, and #).

STEP 2: LED on  key lights and hear key touch tone.

STEP 3: The dialed number appears on the top of LCD.

		2000
1:25 PM	MON 12 JUL 2010	
MIC		>>>

Note: Pressing the Speaker Key or going off-hook is not necessary.

Preset Dial **DT730/710** **DT330**

STEP 1: Enter desired telephone number (Digit Keys 0-9, *, and #).

STEP 2: The dialed number appears on the top of LCD.

Input Dial Number	2000
Clr	Cnl

STEP 3: Lift handset or press  key.
or

STEP 3: Press the originating Line Key and lift handset.

Note: Originating call operation is cancelled by the following Soft Key operation;

- Press Exit key or Cancel Key.
- Press Clear Key and cancel by one digit.

Note: This feature cannot use on ITL-2E-1.

TO ORIGINATE A CALL USING SPEED CALLING (ONE-TOUCH SPEED CALLING KEYS)

DT730/710 **DT330/310**

STEP 1: Press the desired **One-Touch Speed Calling** key, or press **Speaker** key and **One-Touch Speed Calling** key.

To Program

(Available only on DT Series with **One-Touch Speed Calling** key.)

STEP 2: Press **Feature** key.

STEP 3: Press desired **One-Touch Speed Calling** key.

STEP 4: Enter desired telephone number or feature access code on the keypad.
Display indicates the digits dialed.

STEP 5: Press **Feature** key again to save the number.

SPEED SET
1:25 PM MON 12 JUL 2010
MIC DND >>>

To Verify

STEP 1: Press **Feature** key.

STEP 2: Press desired **One-Touch Speed Calling** key.

STEP 3: Display indicates digits programmed.

Note: To program a hook switch for transfer or feature activation, press **Recall** key as first digit. (! displays on LCD.)

Note: To program a pause, press the **Recall** key as any digit other than the first digit. (- displays on LCD.)

Note: To program a Voice Call, press **Transfer** key after dialing station number. (V displays on LCD.)

Note: **One-Touch Speed Calling** key for feature access: **One-Touch Speed Calling** key may be used as a feature key by storing the feature access code. The features may be programmed on a system basis by the Telephony Server Admin. Access codes may be stored in conjunction with telephone numbers. For example, you can program one button to transfer to a certain extension.

LCD Indication of 8LD Display

STEP 1: Press the desired **One-Touch Speed Calling** key and originate a call.

Registered name will be displayed as follows.

For the key to which no name information is registered, the character "SPD" will be displayed.

When registering Name Information of One-touch Speed Calling, you can use uppercase alphabetic, uppercase European or lowercase European characters.

The following tables show available characters for **One-Touch Speed Calling** keys.

ALPHABETIC CHARACTER (UPPERCASE)

DIGIT KEY	1	2	3	4	5	6	7	8	9	0	*	#
CHARACTER	1	A	D	G	J	M	P	T	W	0	*	#
		B	E	H	K	N	Q	U	X		@	&
		C	F	I	L	O	R	V	Y		.	(
		a	d	g	j	m	s	t	Z		,)
		b	e	h	k	n	p	u	w		'	[
		c	f	i	l	o	q	v	x		:]
		2	3	4	5	6	r	8	y		;	!
							s		z		-	?
							7		9		/	

EUROPEAN CHARACTER (UPPERCASE)

DIGIT KEY	1	2	3	4	5	6	7	8	9	0	*	#
CHARACTER	.	A	D	G	J	M	P	T	W	0	*	#
	,	B	E	H	K	N	Q	U	X			
	:	C	F	I	L	O	R	V	Y			
	!	À	È	Ì	5	Ñ	S	Ù	Z			
	?	Á	É	Í		Ò	β	Û	9			
	-	Â	Ê	Î		Ó	7	Ü				
	+	Ã	Ë	Ï		Ô		Û				
	%	Ä	3	4		Ö		8				
	&	Å				Ö						
	/	Æ				Œ						
	(Ç				Ø						
)	2				6						
	=											
	¿											
	¡											
	1											

Note: The shaded area indicates the characters which cannot be entered.

EUROPEAN CHARACTER (LOWERCASE)

DIGIT KEY	1	2	3	4	5	6	7	8	9	0	*	#
CHARACTER	.	a	d	g	j	m	p	t	w	0	*	#
	,	b	e	h	k	n	q	u	x			
	:	c	f	i	l	o	r	v	y			
	!	à	è	ì	5	ñ	s	ù	z			
	?	á	é	í		ò	β	ú	9			
	-	â	ê	î		ó	7	û				
	+	ã	ë	ï		ô		ü				
	%	ä	3	4		õ		8				
	&	å				ö						
	/	æ				œ						
	(ç				ø						
)	2				6						
	=											
	¿											
¡												
1												

Note: The shaded area indicates the characters which cannot be entered.

TO REGISTER NAME ON ONE-TOUCH SPEED CALLING KEY

DT730 DT330

(Available for 8LD Display terminal.)

STEP 1: Press **NAME**.

```
Push Speed Calling Key
1:25 PM  MON 12 JUL 2010
NAME(*)          >>>
```

STEP 2: Press desired **One-Touch Speed Calling** key.

STEP 3: Enter desired name on the keypad. Display indicates the name entered.

```
NEC BNET
^
SET CANCEL CLEAR  >>>
```

STEP 4: Press **SET** to save the name.

```
1:25 PM  MON 12 JUL 2010
NAME          >>>
```

Note: To delete the entry, press **DEL** or **BK** key and delete each one character.

Note: To delete the whole setting, press **CLEAR** key and back to idle status.

To Register Speed Calling Number On 8LD Display

STEP 1: Follow the procedure of **To program** in **To Originate a Call Using Speed Calling (One-Touch Speed Calling Keys)**.

TO ORIGINATE A CALL USING SPEED CALLING - STATION/GROUP

DT730/710 DT330/310

STEP 1: Press  (Redial).

STEP 2: Press the desired speed calling number.

```
LNR[4]/SPD[_ _]      -X
                      XXXXXX
MIC  PICK  FDA  >>>
```

TO ORIGINATE A CALL USING SPEED CALLING - SYSTEM

DT730/710 DT330/310

To Program Speed Calling – System Key (On One-Touch Speed Calling Key)

STEP 1: Press  key.

STEP 2: Press desired **One-Touch Speed Calling** key. The LCD displays previously stored digits.

STEP 3: Dial the “Speed Calling – System” access code and the abbreviated call code.

STEP 4: Press **Feature** key again.

XXXX
1:25 PM MON 12 JUL 2010

SPEED SET
1:25 PM MON 12 JUL 2010

To Operate From Speed Calling – System Key

STEP 1: Press the “Speed Calling – System” key.

XXXX
1:25 PM MON 12 JUL 2010

STEP 2: If the DT Series does not have the “Speed Calling – System” key, dial the “Speed Calling – System” access code, then the abbreviated call code.

To Operate From Directory Key

(Only DT710 Series and DT310 Series are equipped with Directory key.)

STEP 1: Press **Directory** key.

STEP 2: Dial the abbreviated call code (maximum of 4 digits).

ACCOUNT CODE **DT730/710** **DT330/310**

To Enter

- STEP 1: Lift handset or press  key, receive dial tone.
- STEP 2: Enter feature access code, receive service set tone.
- STEP 3: Enter "Account Code" (up to 10 digits).
- STEP 4: Receive dial tone and dial desired number.

Note: For North America, Account Codes can be up to 24 digits.

To Enter Account Code After Authorization Code

- STEP 1: Lift handset or press  key, receive dial tone.
- STEP 2: Enter feature access code for "Authorization Code", receive service set tone.
- STEP 3: Enter "Authorization Code", receive second service set tone.
- STEP 4: Enter "Account Code", receive dial tone, and dial desired number.

Note: Authorization and Account Codes may be up to 20 digits combined (or 34 digits combined).

FORCED ACCOUNT CODE

DT730/710 **DT330/310**

- STEP 1: Lift handset or press  key, receive dial tone.
- STEP 2: Enter feature access code, receive service set tone.
- STEP 3: Enter "Forced Account Code" (up to 10 digits), receive dial tone.

Note: For North America, Account Codes can be up to 24 digits.

Note: For North America, the total number of digits which can be entered for Authorization and Account Codes is 34 digits.

AUTHORIZATION CODE

DT730/710 **DT330/310**

To Enter Without Account Code

- STEP 1: Lift handset or press  key, receive dial tone.
- STEP 2: Enter feature access code, receive service set tone.
- STEP 3: Enter "Authorization Code" (up to 10 digits).
- STEP 4: Receive dial tone, dial desired number.

- Or -

- STEP 4: Lift handset, receive dial tone.

- STEP 5: Dial desired number.
- STEP 6: If an "Authorization Code" is required, caller hears special dial tone.
- STEP 7: Enter "Authorization Code", or call will be denied.

Note: This option is available only if system is programmed with Least Cost Routing.

To Enter With Account Code (see above)

Service set tone is optional depending upon system programming.

Note: If a 4-, 8-, 16- or 32-button display terminal is used, the display indicates all of the digits dialed.

VOICE CALL DT730/710 DT330/310

- STEP 1: Lift handset.
- STEP 2: Dial desired station number.
- STEP 3: Press **Voice**.

VOICE 2000 1:25 PM MON 12 JUL 2010

- STEP 4: Speak to called party.

Using Soft Key

- STEP 1: Lift handset.
- STEP 2: Dial desired station number; **VOICE** Soft Key appears while station is ringing.

2000 1:25 PM MON 12 JUL 2010 MIC VOICE >>>

- STEP 3: Press **VOICE** Soft Key. Speak to called party.

Note: A Voice Call may be programmed on a **One-Touch Speed Calling** key by pressing **One-Touch Speed Calling** key, dialing the extension, and pressing the Transfer key. (V displays if programming on an DT Series with LCD. Save by pressing **One-Touch Speed Calling** key.)

Note: If called party is on their line when a Voice Call is attempted, calling station's display indicates:

VOICE BUSY 1:25 PM MON 12 JUL 2010

Note: A voice call is restricted if called party's station is not a DT Series. Display indicates:

VOICE REST 1:25 PM MON 12 JUL 2010

TO ANSWER A VOICE CALL HANDS FREE **DT730/710** **DT330/310**

- STEP 1: Receive incoming Voice Call.
- STEP 2: Press the **MIC** Soft Key or  key. LED lights.
- STEP 3: Respond hands-free.

Calling station

VOICE 2001 1:25 PM MON 12 JUL 2010

Note: If privacy is required, lift handset.

AUTOMATIC INTERCOM

DT730/710 **DT330/310**

To Initiate

- STEP 1: Lift handset or press  key.
- STEP 2: Press the **AICM** key.
- STEP 3: Hear ringback tone.

Called party



ICM 2 1:25 PM MON 12 JUL 2010
--

To Answer

- STEP 1: **AICM** key flashes red indicating an incoming intercom call.

Overriding party

ICM 1 1:25 PM MON 12 JUL 2010
--

- STEP 2: Press **AICM**, lift handset or press  key. LED lights solid green.
- STEP 3: If called station is engaged in a non-intercom call, the station may press **AICM** after placing original caller on hold (with  key).

To Bridge Into An Automatic Intercom Call

Note: Bridging is an optional feature.

- STEP 1: Press the **AICM** key, lift handset or press  key.

Overriding party

OVERRIDE 1 1:25 PM MON 12 JUL 2010

STEP 2: A three-party conference is established.

CONF 1:25 PM MON 12 JUL 2010
--

MANUAL INTERCOM

DT730/710 **DT330/310**

To Initiate

STEP 1: Press **MICM**, lift handset or press  key, ringback tone is heard.

STEP 2: Press the **SIG** key if it is desired for the called station to hear ringing.

Called party

ICM 2 1:25 PM MON 12 JUL 2010

To Answer

STEP 1: **MICM** key flashes, indicating an incoming call. Ring tone may also be heard.

Calling party

ICM 1 1:25 PM MON 12 JUL 2010

STEP 2: Press **MICM**.

STEP 3: Lift handset or press  key, LED lights

solid green.

STEP 4: If called station is engaged in a non-intercom call, the station may press **MICM** after placing original caller on hold (with  key).

To Bridge Into A Manual Intercom Call

Note: Bridging is an optional feature.

STEP 1: Press **MICM**, lift handset or press  key.

Overriding party

OVERRIDE 1 1:25 PM MON 12 JUL 2010
--

STEP 2: A three-party conference is established.

CONF 1:25 PM MON 12 JUL 2010
--

Note: The **SIG** key signals the corresponding station when speaking over the intercom path is unnecessary.

Note: Two-button Manual Intercom provides one button for signalling and one for talking. A separate signalling button can be used in many ways for the secretary to alert a boss, or vice versa.

DIAL INTERCOM **DT730/710** **DT330/310**

To Initiate

STEP 1: Lift handset or press the  key.

STEP 2: Press **DICM** key.

STEP 3: Dial desired intercom station number. Receive ringback tone.

Called party

ICM	2
1:25 PM MON 12 JUL 2010	

To Answer

STEP 1: **DICM** LED flashes, indicating an incoming intercom call.

STEP 2: Press **DICM**.

STEP 3: Lift handset or press  key. LCD shows solid green.

STEP 4: If called station is engaged in a non-intercom call, the station may press **DICM** after placing the original call on hold (with  key.)

Calling party

ICM	2
1:25 PM MON 12 JUL 2010	

To Bridge Into A Dial Intercom Call

Note: Bridging is an optional feature.

STEP 1: Press the **DICM** key, lift handset or press  key.

Overriding party

OVERRIDE	3
1:25 PM MON 12 JUL 2010	

STEP 2: A three-party conference is established.

CONF
1:25 PM MON 12 JUL 2010

Note: Dial intercom provides a Dial Intercom group where each member of the group may be called by a 1- or 2-digit number without using their prime lines.

CONFERENCE **DT730/710** **DT330/310**

- STEP 1: With call in progress, ask party to hold.
- STEP 2: Press **Transfer** key, receive interrupted dial tone.
- STEP 3: Dial desired number.
- STEP 4: After call is answered, press **Conf** key. The LED lights.
- STEP 5: Three-way conference is established.

CONF
1:25 PM MON 12 JUL 2010

Note: The Conf key is accommodated on only DTL-2E-1, ITL-2E-1 and DTL-6DE-1. If using the terminals without **Conf** key, use a soft key or programmable feature key to which conference feature has been assigned.

Using Soft Key

- STEP 1: With a call in progress, press **Transfer** key and dial desired number.
- STEP 2: After call is answered, press **CONF** Soft Key. Three-way conference is established.

CONF
1:25 PM MON 12 JUL 2010
MIC >>>

- STEP 3: If one party hang up, other two remain con-

nected. **Conf** LED goes out.

TO ESTABLISH A BROKER CALL

DT730/710 **DT330/310**

- STEP 1: While engaged in a call and wishing to consult a third party, press **Transfer** key. Caller is automatically placed on hold.
- STEP 2: Dial desired party to consult.
- STEP 3: Press **Transfer** key to return to original caller. Third party is automatically placed on hold.
- STEP 4: By repeating these steps, it is possible to alternate between calls.

Note: The display indicates connected station or trunk at any given time.

TO ANSWER A CAMPED-ON CALL

DT730/710 **DT330/310**

- STEP 1: While engaged in a call, receive the camp-on indication (one short tone burst). LED of **Answer** key flashes.
- STEP 2: Press **Answer** key. Call in progress is placed on hold.
- STEP 3: Connection to camped-on call is established.
- STEP 4: Press **Answer** key to return to original call. Camped-on call is placed on hold.

STEP 5: By repeating these steps, it is possible to alternate between calls. Display indicates connected station or trunk at any given time.

Trunk type	Trunk number
CAMP ON DDD	3
1:25 PM MON 12 JUL 2010	

CALL WAITING - ORIGINATING

DT730/710 DT330/310

To Program Call Waiting Key (On One-Touch Speed Calling Key)

STEP 1: Press **Feature** key.

STEP 2: Press desired **One-Touch Speed Calling** key.

STEP 3: Press **Recall** key. ! appears on LCD.

STEP 4: Dial "Call Waiting" feature access code.

STEP 5: Press **Feature** key.

Note: To program a hook switch for transfer or feature activation, press **Recall** as first digit. "!" displays on LCD.

To Activate Call Waiting – Originating

STEP 1: Dial desired station number, receive busy tone.

STEP 2: Press **CALL WAITING**.

STEP 3: Receive special ringback tone.

STEP 4: Call waiting tone is sent to busy station.

Called station number
C WAIT 2000
1:25 PM MON 12 JUL 2010

– Or –

STEP 4: Lift handset or press **Speaker** key.

STEP 5: Dial "Call Waiting" access code, receive dial tone.

C WAIT
1:25 PM MON 12 JUL 2010

STEP 6: Dial busy station.

C WAIT SET 2000
1:25 PM MON 12 JUL 2010

Using Soft Key

STEP 1: Dial desired station and receive busy tone.

STEP 2: Press **CW** Soft Key receive call waiting ring-back tone.

Called station
number

C WAIT SET	2000
1:25 PM MON 12 JUL 2010	
MIC	>>>

To Answer A Waiting Call

STEP 1: Call Waiting Tone is heard.

STEP 2: Press **Answer** key.

STEP 3: Waiting call is automatically connected. Original party is placed on hold.

STEP 4: By repeatedly pressing **Answer** key, it is possible to alternate between calls. Display indicates connected station or trunk at any given time.

Calling station
number

C WAIT	2001
1:25 PM MON 12 JUL 2010	

Using Soft Key

STEP 1: Hear burst of tone Display indicates "**C WAIT**" and **Answer** key flashes.

STEP 2: Press **Answer** key receive call waiting tone.

Calling station
number

C WAIT	2001
1:25 PM MON 12 JUL 2010	
MIC	>>>

To Disconnect

STEP 1: Press **Recall** key. Station user is automatically connected to original party.

CALL PARK **DT730/710** **DT330/310**

To Program Call Park Key (On One-Touch Speed Calling Key)

- STEP 1: Press **Feature** key.
- STEP 2: Press **One-Touch Speed Calling** key.
- STEP 3: Press **Recall** key. “!” displays on LCD.
- STEP 4: Dial “Call Park” access code.
- STEP 5: Press **Feature** key again.

To Park A Call

- STEP 1: While connected to a station or trunk, press **CALL PARK**.

Parked station
or trunk

CALLPARK SET	DDD 3
1:25 PM	MON 12 JUL 2010

To Retrieve A Parked Call From Originating Station

- STEP 1: Dial “Call Park” local retrieval code.
- STEP 2: Station user is connected to parked call.

Elapsed time

10:01	DDD 2
1:25 PM	MON 12 JUL 2010

To Retrieve A Parked Call From A Remote Station

- STEP 1: Dial “Call Park” local retrieval code.
- STEP 2: Station user is connected to parked call.

Station that
parked the call

2000	DDD 2
1:25 PM	MON 12 JUL 2010

CALL PICK-UP (GROUP)

DT730/710 **DT330/310**

When Station Within Pick-up Group Rings

- STEP 1: Lift handset.
- STEP 2: Press **CALL PICK-UP** or dial “Call Pick-up” access code (may be stored on **One-Touch Speed Calling** key).
- STEP 3: Connection to calling party is established.
- STEP 4: If currently on a call, press **Transfer** key and dial “Call Pick-up” access code.
The original party is placed on hold.

	Called station	Calling party
PICK UP	2000 DDD	3
1:25 PM	MON 12 JUL 2010	

Using Soft Key

- STEP 1: Lift handset and press **PICK** Soft Key.
- STEP 2: Connection to calling party is established.

	Called station	Calling party
PICK UP	2000	2001
1:25 PM	MON 12 JUL 2010	
MIC		>>>

CALL PICK-UP (DIRECT)

DT730/710 **DT330/310**

To Program Pick-up Direct Key (One-Touch Speed Calling Key)

- STEP 1: Press **Feature** key.
- STEP 2: Press **One-Touch Speed Calling** key.
- STEP 3: Dial “Direct Call Pick-up” access code.
- STEP 4: Press **Feature** key again.

When A Station Within System Rings

- STEP 1: Lift handset, receive dial tone.
- STEP 2: Press **PICK-DIRECT** and dial the station number to be picked up.

– Or –

- STEP 2: Dial “Direct Call Pick-up” access code and the station number to be picked up.
- STEP 3: Connection to calling party is established.
- STEP 4: If busy, original call must be placed on hold before new call can be picked up.

	Called station	Calling party
PICK UP	2000 DDD	3
1:25 PM	MON 12 JUL 2010	

OUTGOING TRUNK QUEUING

DT730/710 DT330/310

If Trunk Is Busy

STEP 1: Receive Trunk Busy indication. Press **CALL BACK**. Call is placed in queue for next available trunk.

STEP 2: When trunk is available, setting station is alerted by ringing and flashing red LED.

STEP 3: Press **Speaker** key or lift handset. Dial tone is heard or number is automatically dialed if Least Cost Routing is provided.

OG-Q SET 1:25 PM MON 12 JUL 2010
--

OFF-HOOK TRUNK QUEUING

DT730/710 DT330/310

STEP 1: Press **Speaker** key, receive dial tone.

STEP 2: Dial desired telephone number. Encounter a trunk busy condition.

STEP 3: Station user receives service set tone and leaves speaker on.

STEP 4: The desired number is automatically dialed when a trunk becomes available.

EXECUTIVE OVERRIDE

DT730/710 DT330/310

If Called Station Is Busy

STEP 1: Press **OVERRIDE**.

STEP 2: Interrupted parties receive warning tone.

Overridden station

OVERRIDE 2001 1:25 PM MON 12 JUL 2010
--

STEP 3: Three-way conference is initiated.

STEP 4: **Conf** LED lights.

CONF 1:25 PM MON 12 JUL 2010
--

Note: The Conf key is accommodated on only DTL-2E-1, ITL-2E-1 and DTL-6DE-1.

Using Soft Key

STEP 1: Press **E-OVR** Soft Key.

STEP 2: Interrupted parties receive warning tone and three-way conference is initiated.

OVERRIDE 2001 1:25 PM MON 12 JUL 2010 MIC >>>
--

Note: Override may be programmed by the Telephony Server Admin. for one of the Programmable feature keys, or may be programmed on a **One-Touch Speed Calling** key by storing the Recall and Override access code.

LAST NUMBER REDIAL

DT730/710 **DT330/310**

To Recall Last Number Dialed

STEP 1: Press **Redial** key. Last number dialed is displayed.

LNR[# or ✕]/SPD[_ _]	-X
	XXXXXX
MIC	PICK FDA >>>

STEP 2: Press **Redial** key until desired number is displayed. Up to 5 previously dialed numbers.

STEP 3: Press **#** or **✕**. The number on the display is automatically redialed.

STEP 4: When party has answered, lift handset or speak hands-free.

Note: A-law Countries [Europe, Australia, Russia, Latin America, Middle near East, other Asian nations]: #
 μ-law Countries [North America, Japan, Hong Kong, Taiwan]: ✕

CALL FORWARDING - ALL CALLS

DT730/710 **DT330/310**

To Set

STEP 1: Press **Speaker** key. Receive dial tone.

STEP 2: If setting for another station, press **MULTI-LINE APPEARANCE**.

STEP 3: Press **FWD** or dial “Call Forwarding – All Calls” access code. Receive special dial tone.

STEP 4: Dial destination station or external telephone number. Receive service set tone.

STEP 5: **FWD** LED lights (at your station or at the DT Series of the multiline station you are setting).

STEP 6: Press **Speaker** key. Call Forwarding – All Calls is set.

Forwarding
station

FORWARD SET	2000
1:25 PM	MON 12 JUL 2010

Using Soft Key

STEP 1: Press **FDA** Soft Key. Receive special tone.

STEP 2: Dial destination; wait for service set tone.

STEP 3: "FORWARD SET" is displayed, call forwarding for all calls is set.

```
FORWARD SET
1:25 PM MON 12 JUL 2010
MIC >>>
```

To Verify (Only For Terminal With LCD)

STEP 1: Press **FWD**.

STEP 2: Display indicates the station number calls are forwarded to.

Forwarding
station

```
FORWARD 2000
1:25 PM MON 12 JUL 2010
```

Note: With Soft Key operation, **FDB** flashes on the display.

To Cancel

STEP 1: Press  key. Receive dial tone. If canceling for another station, press **MULTILINE APPEARANCE**.

STEP 2: Press **FWD** or dial "Call Forwarding – All Calls" cancel code. Receive service set tone. LED goes out at your station (or the DT Series of the multiline station).

STEP 3: Press  key. Call Forwarding – All Calls is cancelled.

```
FORWARD CANCEL
1:25 PM MON 12 JUL 2010
```

Using Soft Key

STEP 1: Press **FDA** Soft Key.



STEP 2: Receive service set tone and "FORWARD CANCEL" is displayed.

```
FORWARD CANCEL
1:25 PM MON 12 JUL 2010
MIC >>>
```

CALL FORWARDING - BUSY LINE

DT730/710 DT330/310

To Set

- STEP 1: Press  key. Receive dial tone.
- STEP 2: If setting for another station, press **MULTI-LINE APPEARANCE**.
- STEP 3: Press **FWD-BY** or dial "Call Forwarding – Busy Line" access code. Receive special dial tone.
- STEP 4: Dial destination station or external telephone number. Receive service set tone.
- STEP 5: **FWD-BY** LED lights (at your station or at the DT Series of the multiline station you are setting).
- STEP 6: Press  key. Call Forwarding – Busy Line is set.

FORWARD SET 1:25 PM MON 12 JUL 2010

Using Soft Key

- STEP 1: Press **FDB** Soft Key. Receive special dial tone.
- STEP 2: Dial destination; wait for service set tone.
- STEP 3: "**FORWARD SET**" is displayed; Call Forward-

ing – Busy Line is set.

FORWARD SET 1:25 PM MON 12 JUL 2010 MIC >>>
--

To Verify (Only For Terminal With LCD)

- STEP 1: Press **FWD-BY**.
- STEP 2: Display indicates the station number calls are forwarded to.

Forwarding station

FORWARD 2000 1:25 PM MON 12 JUL 2010
--

Note: With Soft Key operation, **FDB** flashes on the display.

To Cancel

- STEP 1: Press  key. Receive dial tone. If canceling for another station, press **MULTILINE APPEARANCE**.
- STEP 2: Press **FWD-BY** or dial "Call Forwarding – Busy Line" cancel code. Receive service set tone. LED goes out at your station (or the DT Series of the multiline station).

STEP 3: Press  key. Call Forwarding – Busy Line is cancelled.

FORWARD CANCEL
1:25 PM MON 12 JUL 2010

Using Soft Key

STEP 1: Press **FDB** Soft Key.
STEP 2: Receive service set tone and “**FORWARD CANCEL**” is displayed.

FORWARD CANCEL
1:25 PM MON 12 JUL 2010
MIC >>>

CALL FORWARDING - DON'T ANSWER

DT730/710 **DT330/310**

To Set

STEP 1: Press  key. Receive dial tone.
STEP 2: If setting for another station, press **MULTI-LINE APPEARANCE**.
STEP 3: Press **FWD-NA** or dial “Call Forwarding – Don't Answer” access code. Receive special dial tone.
STEP 4: Dial destination station or external telephone number. Receive service set tone.

STEP 5: **FWD-NA** LED lights (at your station or at the DT Series of the multiline station you are setting).

STEP 6: Press  key. Call Forwarding – Don't Answer is set.

Forwarding station

FORWARD SET **2000**
1:25 PM MON 12 JUL 2010

Using Soft Key

STEP 1: Press **FDN** Soft Key. Receive special dial tone.
STEP 2: Dial destination; wait for service set tone.
STEP 3: “**FORWARD SET**” is displayed; Call Forwarding – Don't Answer is set.

FORWARD SET
1:25 PM MON 12 JUL 2010
MIC >>>

To Verify (Only For Terminal With LCD)

STEP 1: If verifying for another station, press **MULTI-LINE APPEARANCE** while idle.
STEP 2: Press **FWD-NA**.

STEP 3: Display indicates the station number calls are forwarded to.

Forwarding
station

FORWARD	2000
1:25 PM	MON 12 JUL 2010

Note: Call Forwarding for Busy Line and Don't Answer may be combined depending upon system programming.

Note: With Soft Key operation, FDB flashes on the display.

To Cancel

STEP 1: Press  key. Receive dial tone. If canceling for another station, press **MULTILINE APPEARANCE**.

STEP 2: Press **FWD-NA** or dial "Call Forwarding - Don't Answer" cancel code. Receive service set tone. LED goes out at your station (or the DT Series of the multiline station).

STEP 3: Press  key. Call Forwarding – Don't Answer is cancelled.

FORWARD CANCEL
1:25 PM MON 12 JUL 2010

LOGGED OUT IP STATION - CALL DESTINATION **DT730**

To Set

STEP 1: Lift handset or press  key.

STEP 2: Press the FDL Key or dial "Logged Out IP Station – Call Destination" access code.

STEP 3: Dial destination station number; receive service set tone.

STEP 4: Replace handset or press  key. Logged Out IP Station – Call Destination is set.

FORWARD SET	XXXX
1:25 PM	MON 12 JUL 2010

Using Soft Key

STEP 1: Press **FDL** Soft Key; receive special Dial Tone.

STEP 2: Dial destination station number.

STEP 3: Receive service set tone; "**FORWARD SET**" is displayed.

FORWARD SET	XXXX
1:25 PM	MON 12 JUL 2010
MIC	>>>

CALL BACK **DT730/710** **DT330/310**

If Called Station is Busy

STEP 1: Press CALL BACK. Receive service set tone.

Called party

CALLBACK SET 2000 1:25 PM MON 12 JUL 2010

– Or –

STEP 1: Press the **FLASH** key and enter “Call Back” access code.

STEP 2: When both parties become idle, calling party's phone rings. Calling party would go off hook and hear ring back tone.

The called station would then be ringing.

Called party

CALLBACK 2000 1:25 PM MON 12 JUL 2010

STEP 3: Connection is established when the called party answers.

Called party

CALLBACK 2001 1:25 PM MON 12 JUL 2010

Note: Call Back may be programmed by the Telephony Server Admin. on a Programmable feature key or by the user on a **One-Touch Speed Calling** key.

Using Soft Key

STEP 1: Press **CB** Soft Key and receive service set tone.

STEP 2: “**CALLBACK SET**” is displayed and the **CB** Soft Key flashes on the display.

CALLBACK SET 1:25 PM MON 12 JUL 2010 MIC >>>

TO SAVE AND REPEAT A NUMBER

DT730/710 **DT330/310**

To Save

STEP 1: Press  key.

STEP 2: Dial desired telephone number.

STEP 3: Press **S&R**. Dialed number is now stored. **S&R** LED lights.

– Or –

STEP 3: Receive internal call.

STEP 4: Press **S&R**. Number is stored in memory.

STEP 5: **S&R** LED lights.

Using Soft Key

STEP 1: Press **S&R**. Number is stored in memory.

STEP 2: **S&R** LED lights.

To Verify (Only For Terminal With LCD)

STEP 1: While idle, press **S&R**.

STEP 2: Display indicates digits sorted.

To Repeat

STEP 1: Press  key.

STEP 2: Press **S&R**. DT Series automatically redials the programmed number.

STEP 3: **S&R** automatically cancelled. LED goes out.

Note: If saved number is busy or no answer is received, to save it again, press **S&R** again before hanging up.

Using Soft Key

STEP 1: Press flashing **S&R** Soft Key. Stored number is automatically redialed. "**S&R**" disappears from display.

TO LEAVE A MESSAGE

DT730/710 DT330/310

- STEP 1: Press  key. Receive dial tone.
- STEP 2: Dial desired station number. Encounter no answer or busy condition.
- STEP 3: Press **MSG**. Message is sent to called DT Series.
- STEP 4: Called station **MSG** LED lights.

Called station

MESSAGE SET	2001
1:25 PM	MON 12 JUL 2010

Note: Up to four messages can be stored in DT Series memory.

Note: If a fifth message is attempted, reorder tone is heard and display indicates as follows:

MESSAGE BUSY
1:25 PM MON 12 JUL 2010

Note: If station is not equipped to receive messages, reorder tone is heard and display indicates as follows:

MESSAGE REST
1:25 PM MON 12 JUL 2010

TO ANSWER A MESSAGE

DT730/710 DT330/310

To Display

- STEP 1: **MSG** LED is lit. Station is idle.
- STEP 2: Press **MSG**.
- STEP 3: Re-press **MSG** to display additional messages in order received.

Calling station

MSG 2001	12:28PM
1:25 PM	MON 12 JUL 2010

To Respond

- STEP 1: While displaying desired message, press  key.
- STEP 2: Press **MSG**. Station which left message is automatically redialed.
- STEP 3: Message is erased.

To Erase

- STEP 1: To erase a message without returning the call, press **MSG** to display desired message.

STEP 2: Dial # or * while message displays. Message is erased.

MESSAGE CANCEL
1:25 PM MON 12 JUL 2010

Note: If station that left message is busy, callback or **MSG** may be set. If station that left message does not answer, **MSG** may be set, notifying originating party that a message return was attempted.

VOICE MAIL SYSTEM

DT730/710 DT330/310

To Set

STEP 1: Press **Feature** key.

STEP 2: Press **(Enter)** or **Message** key.

STEP 3: Dial desired "Voice Mail System" access code.

STEP 4: Press **Feature** key again.

SPEED SET
1:25 PM MON 12 JUL 2010

To Originate

STEP 1: Press **Message** key.

STEP 2: Hear ringback tone.

– Or –

STEP 2: Press **(Enter)** key. The Shortcut menu screen is displayed on LCD.

STEP 3: Select **2 Voice Mail** and then press **(Enter)**, **(Right-cursor)** or **OK** soft key to access a preset Voice Mail System.

STEP 4: Hear ringback tone.

MEET-ME PAGING

DT730/710 DT330/310

Example:

Station A can page Station B. When Station B dials answer code, they are connected.

To Page (Station A)

STEP 1: Dial "Paging" access code, receive continuous ringback for one second.

STEP 2: Page station B.

STEP 3: Remain off hook or hang up.

Trunk number

PAGING **3**
1:25 PM MON 12 JUL 2010

To Answer (Station B)

If Station A remains off hook

STEP 1: Station B dials “Paging” answer code, and they are immediately connected.

PAGING 1:25 PM MON 12 JUL 2010	3
--	----------

If Station A hung up

STEP 1: Station B dial “Paging” answer code, and Station A DT Series rings.

STEP 2: When station A goes off-hook, they are connected.

Note: Paging function can not be supported with IP enabled DT700 Series.

PAGING TRANSFER

DT730/710 **DT330/310**

Example:

Station A receives an important call for Station B who is not at a desk. Station A can page Station B. When Station B dials the Paging answer code, Station A can announce the call and transfer it to Station B.

Calling trunk
number

TRANSFER 1:25 PM MON 12 JUL 2010	DDD 3
--	--------------

Station A Paging

STEP 1: Ask calling party to hold.

STEP 2: Press **Transfer** key. Receive interrupted dial tone.

STEP 3: Dial “Paging” access code. Receive continuous ringback for one second.

STEP 4: Page Station B.

STEP 5: Remain off-hook or hang up.

To Answer (Station B)

If Station A remained off hook

STEP 1: Station B dials “Paging” answer code, and is connected with Station A. Station A announces call.

Stations A and B each display
the other’s number

TRANSFER 1:25 PM MON 12 JUL 2010	XXXX
--	-------------

STEP 2: Station A hangs up. Station B and the calling party are connected.

DDD 3
1:25 PM MON 12 JUL 2010

PAGING	DDD 3
1:25 PM	MON 12 JUL 2010

If Station A hung up

STEP 1: Station B dials "Paging" answer code. Station A DT Series rings.

Stations A and B each display the other's number, flashing

TRANSFER	DDD 3
1:25 PM	MON 12 JUL 2010

STEP 2: Station A picks up and announces call.

STEP 3: Station A hangs up. Station B and the calling party are connected.

Calling trunk number

DDD 3
1:25 PM MON 12 JUL 2010

- Or -

(Dependent on System Programming)

STEP 3: Station B dials "Paging" answer code, and is immediately connected to the calling party.

BOSS/SECRETARY TRANSFER

DT730/710 **DT330/310**

Secretary

STEP 1: Lift handset, press boss' ringing line. Ask calling party to hold.

Calling party

DDD 3
1:25 PM MON 12 JUL 2010

STEP 2: Press boss' line again. "Voice Call" is automatically established.

Boss and secretary station each display the other's number

ICM	XXXX
1:25 PM MON 12 JUL 2010	

STEP 3: Announce the call to the boss.

If Boss Accepts Call

STEP 1: Secretary replaces handset.

STEP 2: Secretary presses boss' line to return to calling party.

If Boss Refuses Call

STEP 1: Secretary presses boss' line to return to calling party.

BOSS/SECRETARY - MW LAMP CONTROL **DT730/710** **DT330/310**

To Set MW at Boss' Station

With caller on the line

STEP 1: Lift handset or press  key.

STEP 2: Press boss' ringing line. Ask calling party to hold.

STEP 3: Press the **MW-SET** line/feature key. No service set tone is heard.

MW SET
1:25 PM MON 12 JUL 2010

Boss sees **MW** on display and can call secretary to receive message.

Without caller on the line

STEP 1: After taking message, press  key and receive dial tone.

STEP 2: Press the **MW-SET** line/feature key. Receive service set tone.

MW SET
1:25 PM MON 12 JUL 2010

Note: The secretary can hang up after taking a message, and set a message lamp at any time by going off-hook on the boss' multiline and pressing the **MW-SET** key.

To Cancel At Boss' Station

With caller on the line

- STEP 1: Lift handset or press  key. Receive dial tone.
- STEP 2: Press Boss' line appearance.
- STEP 3: Press **MW-CANCEL** line/feature key. Receive service set tone.

MW	CANCEL
1:25 PM	MON 12 JUL 2010

With caller on the line

- STEP 1: While engaged in conversation on boss' multiline, press **MW-CANCEL** key. No service set tone is heard.

MW	CANCEL
1:25 PM	MON 12 JUL 2010

BOSS SECRETARY OVERRIDE



DT730/710 **DT330/310**

Example:

Station 2000 is boss, Station 2001 is secretary.
Boss is connected to Trunk A.

Incoming call on Trunk B connects to secretary, but is intended for boss.

To Program Boss/Secretary Override Key

- STEP 1: Press  key.
- STEP 2: Press a **One-Touch Speed Calling** key.
- STEP 3: Dial "Boss/Secretary Override" access code.
- STEP 4: Press  key. – displays on LCD.
- STEP 5: Dial boss' station number.
- STEP 6: Press  key again.

Secretary

- STEP 1: Lift handset to answer Trunk B, ask caller to hold.
- STEP 2: Press **CALL HOLD** feature key or  key and dial call hold access code. Receive Dial Tone.

STEP 3: Press **BOSS/SEC OVERRIDE**. Receive Ringback Tone.

Boss' station number

C WAIT	2000
1:25 PM	MON 12 JUL 2010

Boss

STEP 1: Hear 3 bursts of tone. LCD indicates:

Secretary's station number

C WAIT	2001
1:25 PM	MON 12 JUL 2010

Option 1

STEP 1: Boss presses **Answer** key and converses with secretary. Trunk A is placed on hold.

STEP 2: Secretary hangs up. Boss is connected to Trunk B.

STEP 3: Boss can alternate between the two parties by pressing **Answer** key.

Option 2

STEP 1: Boss presses **Answer** key and converses with secretary. Trunk A is placed on hold.

STEP 2: Boss presses station 01 key and converses with Trunk B. Boss presses **Answer** key to re-

connect to Trunk A.

STEP 3: Secretary hears reorder tone, hangs up.

STEP 4: Boss can alternate between the two parties by pressing **Answer** key.

Option 3

STEP 1: If boss does not respond to 3 bursts of tone, secretary presses **Recall** key.

STEP 2: Secretary is connected to Trunk B.

Option 4

STEP 1: Boss presses **Answer** key and converses with Secretary. Trunk A is placed on hold.

STEP 2: Boss denies call, presses **Transfer** key to return to Trunk A.

STEP 3: Secretary is returned to Trunk B.

DO NOT DISTURB **DT730/710** **DT330/310**

While Idle (On Hook)

STEP 1: Press **DND**. LED lights.

DND SET	
1:25 PM	MON 12 JUL 2010

Note: With Soft Key operation, "DND" flashes when set.

To Cancel

STEP 1: Press **DND**. LED goes out.

DND CANCEL 1:25 PM MON 12 JUL 2010
--

Using Soft Key

STEP 1: Press flashing **DND** Soft Key.

DND CANCEL
MIC DND >>>

Note: **DND** must be programmed by the Telephony Server Admin. on a Programmable feature key.

CALL REDIRECT **DT730/710** **DT330/310**

Example:

DT Series Station A views on the DT Series display the Station Number or Caller ID of an Incoming Call and immediately redirects the call by pressing a Function Key. The destination of the Call Redirect will be the Call Forwarding-Don't Answer Destination or the Recall Destination if the call is transferred without Call Forwarding-Don't Answer being set at the station.

Note: This feature is available in North America only.

Call Redirect To Call Forward-Don't Answer Destination

STEP 1: Station A sets Call Forward-Don't Answer to Station B.

STEP 2: Station C dials Station A, it rings and displays Station C's number on the display.

STEP 3: Station A presses the Call Redirect Key.

STEP 4: REDIRECT is displayed on the LCD, and the call immediately forwards to Station B.

Using Soft Key

STEP 1: Station A sets Call Forward-Don't Answer to Station B.

STEP 2: Station C dials Station A, it rings and displays Station C's number on the display.

STEP 3: Station A presses the REDIR Soft Key.

STEP 4: REDIRECT is displayed on the LCD, and the call immediately forwards to Station B.

- Or -

Call Redirect to Recall Destination When Call Is Transferred Without Call Forwarding-Don't Answer Being Set

STEP 1: Station B calls Station C.

STEP 2: Station C answers the call and transfers it to Station A and then releases the call.

STEP 3: Station A rings.

STEP 4: Station A presses the Call Redirect Key.

STEP 5: REDIRECTING is displayed on Station A and the call immediately recalls to Station C.

Using Soft Key

STEP 1: Station B calls Station C.

STEP 2: Station C answers the call and transfers it to Station A and then releases the call.

STEP 3: Station A rings.

STEP 4: Station A presses the REDIR Soft Key.

STEP 5: REDIRECTING is displayed on Station A and the call immediately recalls to Station C.

PRIVACY DT730/710 DT330/310

While Off-Hook

STEP 1: Press **DND**. LED lights.

STEP 2: Privacy feature prevents interruptions for the duration of the call.

PRIVACY SET
1:25 PM MON 12 JUL 2010

Using Soft Key

STEP 1: Press flashing **DND** Soft Key. "DND" flashes when set.

STEP 2: Privacy feature prevents interruptions for the duration of the call.

PRIVACY SET
1:25 PM MON 12 JUL 2010
MIC >>>

To Cancel

STEP 1: Press **DND**. LED goes out.

PRIVACY CANCEL
1:25 PM MON 12 JUL 2010

- Or -

STEP 1: Replace handset. Privacy feature is automatically cancelled.

Note: DND must be programmed by the Telephony Server Admin. on a Programmable feature key.

Using Soft Key

STEP 1: Press flashing **DND** Soft Key.

PRIVACY CANCEL 1:25 PM MON 12 JUL 2010 MIC DND >>>

PRIVACY RELEASE

DT730/710 **DT330/310**

Example:

DT Series Station B is engaged in a conversation, and allows DT Series Station A to enter the call in progress.

STEP 1: Station A lifts handset or presses  key. Station A presses the line appearance of Station B.

Warning tone is sent to the interrupted parties (optional).

A three-way conference is established.

CONF 1:25 PM MON 12 JUL 2010
--

Note: Station A may also be a single-line station as long as it appears on the Station B DT Series.

– OR –

Example:

DT Series Station A requests entrance into Station B's call in progress.

STEP 1: Station A lifts handset or presses  key.

STEP 2: Station A presses the line appearance of Station B.

WAIT P-RLS? 1:25 PM MON 12 JUL 2010

STEP 3: Station B LCD indicates as follows:

P-RLS? 1:25 PM MON 12 JUL 2010
--

STEP 4: Station B may allow Station A to enter the conversation by pressing **P-RLS**.

STEP 5: Warning tone is sent to the interrupted parties (optional).

STEP 6: A three-way conference is established.

CONF 1:25 PM MON 12 JUL 2010
--

Note: Station A can be a single-line station if it appears on the Station B DT Series.

Note: Up to six parties can break into a two-party conversation (additional device is required).

PHONEBOOK **DT730/710** **DT330/310**

There are two types of Phonebook features: Local Phonebook and System Phonebook.

Note: This feature is available for DT series with LCD.

Note: When the system administrator invalidates the Phonebook, this feature cannot be used. For details contact the system administrator.

System Phonebook

System Phonebook is used on a system basis. The data entry is made by the Telephony Server Administrator.

Local Phonebook

Local Phonebook is used on a station basis. Up to 100 entries are available per station. You can make entries with key operation from the telephone. Up to 32 digits can be registered for each dial number. Up to 24 characters can be registered for each name.

- **SYSTEM PHONEBOOK**

To Search And Make A Call

Example: To Search For "NEC BNET".

STEP 1: Press **Pbook** soft key while Station is in Idle state.



If Local Phonebook is enabled by the setting on the system side, go to STEP2.
 If Local Phonebook is disabled by the setting on the system side, go to STEP 3.

- OR -

Press key to display the Menu screen.
 On the Menu screen, select **2** Directory.

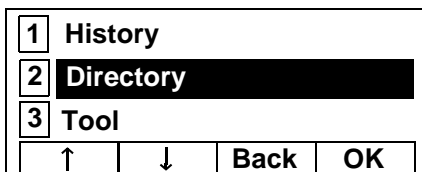

Note: Select an item on the menu screen in either of the following two ways.

- Press an appropriate digit key.
- Highlight a desired item and then press

or **OK** soft key.

If Local Phonebook is enabled by the setting on the system side, go to STEP 2.
 If Local Phone is disabled, the display changes as follows. In that case, select **2** **System** and go to STEP 3.

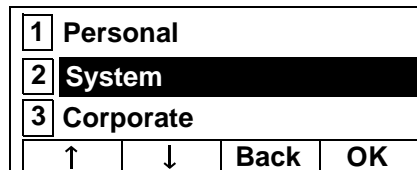

Note: This feature cannot be activated from the Menu key on DT710 Series (ITL-6DE-1).

STEP 2: Press **Sys** soft key.

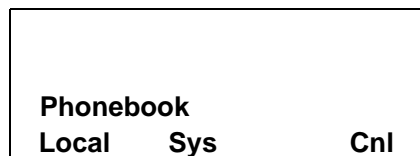

STEP 3: Enter a name and then press or **OK** soft key to perform a search.

Ex. To enter "NEC":

Press **6** key twice to enter "N".

Press **3** key four times to enter "E".

Press **2** key twice to enter "C".

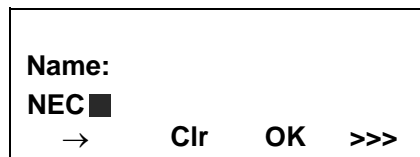

Note: If ">>>" soft Key is pressed on the above screen, the following soft keys appear. Pressing or **Eu-s/Eu-l** soft key shifts characters between uppercase and lowercase.

(Lower-case character)

<<< -Eu-s Cnl

(Upper-case character)



<<< -Eu-l Cnl

Note: To delete an entered character, press  or **Clr** soft key.

Note: To move the cursor one space to the right, press  key or “→” soft key once

STEP 4: A result of the search is displayed. Press  or **UP/DOWN** soft key to scroll the result.

Name: NEC
NEC ABIKO
UP DOWN OK Cnl

STEP 5: When “NEC BNET” appears, press ,  or **OK** soft key.

Name: NEC
NEC BNET
UP DOWN OK Cnl

STEP 6: The registered Phonebook data for “NEC BNET” appears. From this screen, you can make a call by going off-hook or pressing  key.

Name: NEC BNET
Number: XXXXXXXX
More Cnl

Note: **More** soft key appears in Phonebook data screen when the number of characters (name) or digits (telephone number) are exceeding displayable limit (Up to 17 characters or digits can be displayed at a time). If the name or telephone number exceeds the displayable limit, press  or **More** soft key to display the last 17 characters/digits of the name/telephone number.

Example:
Name Suzuki Taro(JapanSumida) ~ 24 characters
Number: 01234567890123456789 ~ 20 digits

Name : Suzuki Taro(Japan
Number : 01234567890123456
More Cnl >>>

(Display area)
Name: Suzuki Taro(JapanSumida)
Number: 01234567890123456789

Name : Taro(JapanSumida)
Number : 34567890123456789
More Cnl >>>

(Display area)
Name: Suzuki Taro(JapanSumida)
Number: 01234567890123456789

• LOCAL PHONEBOOK

To Add New Data

Example:

DT Series Station A registers “NEC” as new name and its Telephone Number.

STEP 1: Press **Pbook** soft key or  (Directory) key while Station is in Idle state.

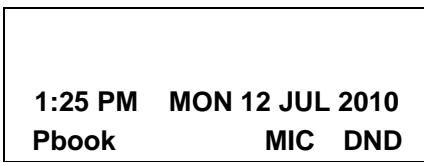

- OR -

Press  key to display the Menu screen. On the Menu screen, select **2 Directory**.

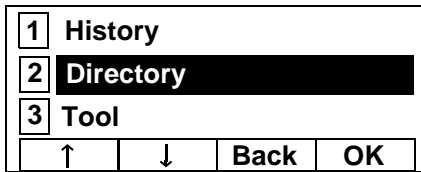

Note: Select an item on the menu screen in either of the following two ways.

- Press an appropriate digit key.
- Highlight a desired item and then press

 or **OK** soft key.

STEP 2: Press **Local** soft key.

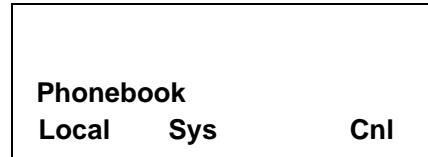

STEP 3: Local Phonebook screen appears. Press **Add** soft key.

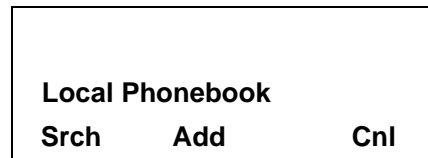

STEP 4: Enter a name and then press  or **OK** soft key.

Ex. To enter “NEC”:

Press **6** key twice to enter “N”.

Press **3** key twice to enter “E”.

Press **2** key three times to enter “C”.

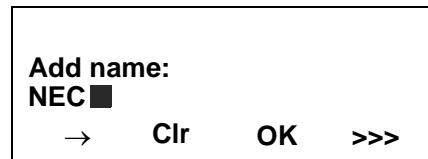

Note: If “>>>” soft Key is pressed on the above screen, the following soft keys appear. Pressing  or **Eu-s/Eu-l** soft key shifts characters between uppercase and lowercase.

(Lower-case character)



(Upper-case character)

<<< -Eu-I Cnl

Note: To delete an entered character, press  or **Clr** soft key.

Note: To move the cursor one space to the right, press  key or “→” soft key once

STEP 5: Enter the telephone number by using digit keys and press  or **OK** soft key.

Name: NEC
Number: ■
Clr OK Cnl

Note: To delete an entered digit, press  or **Clr** soft key.

STEP 6: “NEC” and its telephone number has been added into Local Phonebook. Two seconds later, the display returns to Local Phonebook screen.

Entry added!

To Search For Name

The procedure shown below is available in Local Phonebook.

Example: To Find “NEC BNET”.

STEP 1: While Local Phonebook screen is displayed, press **Srch** soft key. (If no data is registered in Local Phonebook, the message “Local phone book empty” appears.)

Local Phonebook
Srch Add Cnl

STEP 2: Name Entry screen appears.

Name:
■
→ Clr OK >>>

STEP 3: Enter a name (in this example, “NEC” is entered) and then press  or **OK** soft key. (If no appropriate data exists, the message “Entry not found!” appears.)

Name:
NEC ■
→ Clr OK >>>

Note: If “>>>” soft Key is pressed on the above screen, the following soft keys appear. Pressing  or **Eu-s/Eu-I** soft key shifts characters between uppercase and lowercase.

(Lower-case character)

<<< -Eu-s Cnl

(Upper-case character)



<<< -Eu-l Cnl

Note: To delete an entered character, press  or **Clr** soft key.

Note: To move the cursor one space to the right, press  key or “→” soft key once

STEP 4: A result of the search is displayed. Press  or **UP/DOWN** soft key to scroll the result.

Name: NEC
NEC ABIKO
UP DOWN OK Cnl

STEP 5: When “NEC BNET” appears, press ,  or **OK** soft key.

Name: NEC
NEC BNET
UP DOWN OK Cnl

STEP 6: The registered data for “NEC BNET” appears.
From this screen, you can make a call by going off-hook or pressing  key.

Name: NEC BNET
Number: XXXXXXXX
More Pref Cnl >>>

Note **More** soft key appears in Phonebook data screen when the number of characters (name) or digits (telephone number) are exceeding displayable limit (Up to 17 characters or digits can be displayed at a time). If the name or telephone number exceeds the displayable limit, press  or **More** soft key to display the last 17 characters/digits of the name/telephone number.

To Edit An Entry

Example:

To Modify Name "Home" to "House" and Telephone Number "0123456789" to "0123456712".

STEP 1: Press >>> soft key while the target Phone-book data is displayed.

Name: Home Number: 0123456789 More Pref Cnl >>>

STEP 2: Press **EDIT** soft key.

Name: Home Number: 0123456789 <<< EDIT DEL
--

STEP 3: The following name edit screen appears.

Edit Name: Home █ → Clr OK >>>
--

STEP 4: Press  or **Clr** soft key two times to erase "me".

Edit Name: Ho █ → Clr OK >>>
--

STEP 5: Enter "use" by using digit keys. After the modification has completed, press  or **OK** soft key.

Press **8** key twice to enter "u".

Press **7** key four times to enter "s".

Press **3** key twice to enter "e".

Edit Name: House █ → Clr OK >>>

Note: If ">>>" soft Key is pressed on the above screen, the following soft keys appear. Pressing  or **Eu-s/Eu-l** soft key shifts characters between uppercase and lowercase.

(Lower-case character)

<<< -Eu-s Cnl

(Upper-case character)

<<< -Eu-l Cnl

Note: To delete an entered character, press  or **Clr** soft key.

Note: To move the cursor one space to the right, press  key or "→" soft key once.

STEP 6: The following number edit screen appears.

Name: House Number: 0123456789 █ Clr OK Cnl

STEP 7: Press  or **Clr** soft key twice to erase "89".

Name: House
Number: 01234567■
Clr OK Cnl

STEP 8: Enter "12" by pressing digit keys and then press  or **OK** soft key.

Name: House
Number: 0123456712
Clr OK Cnl

STEP 9: The data modification has completed. Two seconds later, the display returns to Local Phonebook screen.

Entry edited!

To Delete A Record

STEP 1: Press >>> soft key while the target Phonebook data is displayed.

Name: NEC ABIKO
Number: 0123456789
More Pref Cnl >>>

STEP 2: Press **DEL** soft key.

Name: NEC ABIKO
Number: 0123456789
<<< EDIT DEL

STEP 3: Press  or **OK** soft key to delete the currently displaying data.

Name: NEC ABIKO
Delete this entry?
OK Cnl

STEP 4: The data deletion has completed. Two seconds later, the display returns to Name Entry screen.

Entry deleted!

To Add A Prefix To Telephone Number

The procedure shown below is available in Local Phonebook.

Example:

To add a prefix "0184" in front of telephone number "0123456789"

STEP 1: Press **Pref** Soft Key while the target Phonebook data is displayed.

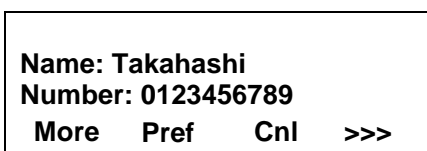

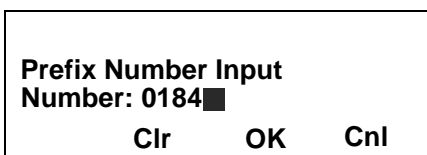

STEP 2: Enter a prefix (In this example, "0184" is entered) by using digit keys and press  or **OK** Soft Key.

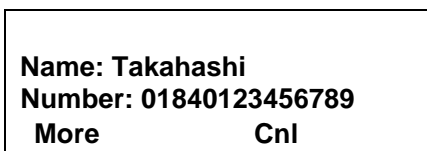

Note: To delete an entered digit, press  or **Clr** soft key.

STEP 3: The prefix is added in front of the telephone number. Once the prefix is added, **Pref** Soft Key will disappear.



Note: **More** soft key appears in Phonebook data screen when the number of characters (name) or digits (telephone number) are exceeding displayable limit (Up to 17 characters or digits can be displayed at a time). If the name or telephone number exceeds the displayable limit, press  or **More** soft key to display the last 17 characters/digits of the name/telephone number.

Available Characters In Local Phonebook

The following tables show available characters in Local Phonebook.

UPPERCASE CHARACTER

Digit Code	1	2	3	4	5	6	7	8	9	0	*	#
Character	.	A	D	G	J	M	P	T	W	SP	*	#
	,	B	E	H	K	N	Q	U	X	0		
	:	C	F	I	L	O	R	V	Y			
	!	À	È	Ì	5	Ñ	S	Ú	Z			
	?	Á	É	Í		Ò	β	Ú	9			
	-	Â	Ê	Î		Ó	7	Û				
	+	Ã	Ë	Ï		Ô		Ü				
	%	Ä	3	4		Ö		8				
	&	Å				Ö						
	/	Æ				Œ						
	(Ç				Ø						
)	2				6						
	=											
	¿											
	¡											
	1											

SP: Blank Space

LOWERCASE CHARACTER

Digit Code	1	2	3	4	5	6	7	8	9	0	*	#
Character	.	a	d	g	j	m	p	t	w	SP	*	#
	,	b	e	h	k	n	q	u	x	0		
	:	c	f	i	l	o	r	v	y			
	!	à	è	ì	5	ñ	s	ù	z			
	?	á	é	í		ò	β	ú	9			
	:	â	ê	î		ó	7	û				
	\	ä	ë	ï		ô		ü				
	“	å	3	4		õ		8				
	@	æ				ö						
	1	ç				6						
		2										

SP: Blank Space

CALL HISTORY DT730/710 DT330/310

There are two types of Call History features. On the one hand, the history data is stored in the system memory. On the other hand, the history data is stored in the memory of the telephone (see [7.CALL HISTORY OPERATION](#)).

The following describes the operating procedures for the Call History feature which controlled by the system. This Call History feature can store up to 20 records. If exceeding 20 records, a record will be deleted in order of occurrence. Also, this Call History feature can store up to 32 digits of dial number and 16 characters of name information per record.

Note: When the system administrator invalidates the Phonebook, this feature cannot be used. For details contact the system administrator.

To View Call History

STEP 1: Press **iCall** soft key of **Call History** Feature key while the current time is displayed on LCD.

5:25 PM	MON 12 JUL 2010
iCall	MIC DND

- OR -

STEP 1: Press Menu key to display the Menu screen. On the Menu screen, select 1 **History** (for DT730 Series)/1 **Call History** (for DT330

Series) and then press or **OK** soft key. (or press 1 key.)

1	History
2	Directory
3	Tool
	↓ Back OK

Note: This feature cannot be activated from the Menu key on DT710 Series (ITL-6DE-1).

STEP 2: The history data of the last received call is displayed.

1:03 PM	MON 12 JUL 2010
	31300
↑	↓ Pbook >>>

Note: If no history data is saved, "NO LIST" will be displayed on LCD.

STEP 3: Press or **↑/↓** soft key to display a desired history data.

12:55 PM	MON 12 JUL 2010
!!	51500
↑	↓ Pbook >>>

Note: Call History will display "!!" for an unanswered incoming call.

To Make A Call From Call History

STEP 1: Display the history data of the target party.

12:55 PM	MON 12 JUL 2010		
	51500		
↑	↓	Pbook	>>>

STEP 2: Go off-hook or press  key to make a call to the displayed party.

Note: While the history data is displayed, you cannot make a call by dialing a telephone number.

To Make A Call With Prefix

STEP 1: Press >>> soft key while the history data to which you want to add a prefix.

1:03 PM	MON 12 JUL 2010		
	31300		
↑	↓	Pbook	>>>

STEP 2: Press **Pref** soft key.

1:03 PM	MON 12 JUL 2010		
	31300		
<<<	Pref	DEL	END

STEP 3: Enter a prefix by using the digit keys. In this example, "012345" is entered. After entering the prefix, press  or **OK** soft key.

Prefix Number Input
Number:■
Clr OK Cnl

Note: A maximum of 10 digits (0-9, * and #) can be set as a prefix.

Note: When prefix is added, up to 32 digits including the prefix can be sent as dial number.

Note: To delete an entered character, press  or **Clr** soft key.

STEP 4: If the call history data has name information, the name is displayed as follows:

Name	:NEC ABIKO
Number	:01234531300■
More	Cnl

Note: **More** soft key appears in Phonebook data screen when the number of characters (name) or digits (telephone number) are exceeding displayable limit (Up to 17 characters or digits can be displayed at a time). If the name or telephone number exceeds the displayable limit, press  or **More** soft key to display the last 17 characters/digits of the name/telephone number.

STEP 5: Go off-hook or press  key to make a call to the displayed telephone number.

To Delete A Specific Data

STEP 1: Press >>> soft key while the history data which you want to delete is displayed.

```
1:03 PM  MON 12 JUL 2010
                31300
  ↑   ↓   Pbook  >>>
```

STEP 2: Press DEL soft key.

```
1:03 PM  MON 12 JUL 2010
                31300
<<<  Pref  DEL  END
```

Note: If you want to exit Call History, press END soft key.

To Add Call History Data To Local Phonebook

Note: The Call History data stored on the system can be added to Phonebook (controlled by the system) only. The data cannot be added to the Personal Directory (described in 6.DIRECTORY OPERATION) controlled by the telephone.

STEP 1: Press Pbook soft key or Phonebook Feature key while the history data of the target party.

```
1:03 PM  MON 12 JUL 2010
                31300
  ↑   ↓   Pbook  >>>
```

Note: Local Phonebook feature allows you to register up to 100 records. If exceeding 100 records at this point, the error message shown below appears. Press OK soft key to go back to the above display.

```
Entry NG (over)
                OK
```

STEP 2: Enter a desired name and then press OK soft key.

(In this example, "NEC ABIKO" is entered.)

```
Add name:
NEC ABIKO■
  →   Clr   OK   >>>
```

Note: If name information is stored on the call history, the name is displayed.

Note: If ">>>" soft Key is pressed on the above screen, the following soft keys appear. Pressing  or Eu-s/Eu-l soft key shifts characters between uppercase and lowercase.

(Lower-case character)

```
<<<  -Eu-s      Cnl
```

(Upper-case character)

```
<<<  -Eu-l      Cnl
```

STEP 3: The telephone number stored on the call history is displayed. The telephone number can be changed if necessary. Press **OK** soft key to add the displayed data to Local Phonebook.

Name :NEC ABIKO
Number :31300■
Clr OK Cnl

This page is for your notes.

6. DIRECTORY OPERATION

This chapter explains about Personal Directory function of DT730 Series. By using Personal Directory function, you can make a call with simple operation.

Personal Directory function can register up to 500 entries (4 telephone numbers per entry). You can add/view/edit/delete these entries.

- TO ADD NEW DATA
- TO CHANGE GROUP NAME
- TO FIND A REGISTERED DATA
- TO MAKE A CALL FROM DIRECTORY
- TO ADD PREFIX TO NUMBER
- TO EDIT DIRECTORY DATA
- TO DELETE ALL DATA
- TO DELETE A SPECIFIC DATA

TO ADD NEW DATA **DT730**



Note: A maximum of 500 entries can be registered in Directory.

STEP 1: While indicating the current time on LCD, press  key to open the **Menu** screen.

OR

Press  (**Directory**) key. The **Directory** screen shown at STEP 3 can be directly displayed.

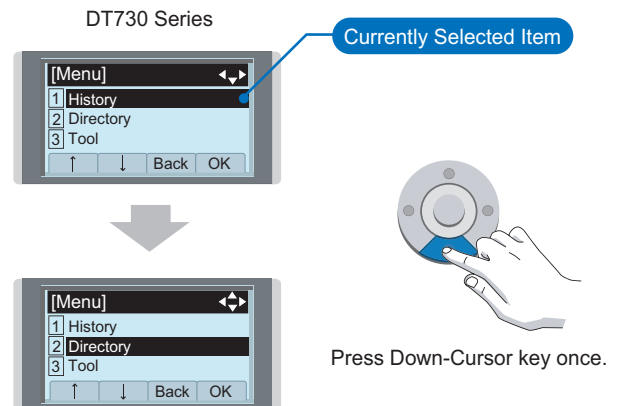

Note: Directory feature is available for DT730 Series only. DT710/DT330/DT310 Series does not support the directory feature.

Note: On the Menu screen, use  or  soft key to move the cursor up/down a line.



STEP 2: Select **2** **Directory**.

Select an item by either of the following operations.

- Highlight an item by using , and then press ,  or **OK** soft key.
- Press **2** key.



STEP 3: Select 1 Personal.

Select an item by either of the following operations.

- Highlight an item by using , and then press , or **OK** soft key.
- Press 1 key.

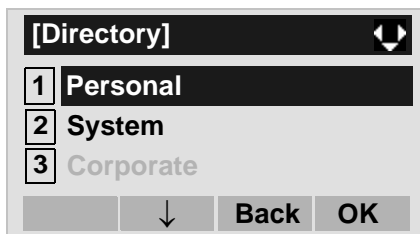

Note: When using Phonebook feature is disabled, this screen will not be displayed. In that case, skip this step.

STEP 4: Select 2 Edit.

Select an item by either of the following operations.



- Highlight an item by using , and then press , or **OK** soft key.

- Press 2 key.



STEP 5: Select 1 Name.

Select an item by either of the following operations.

- Highlight an item by using , and then press , or **OK** soft key.
- Press 1 key.

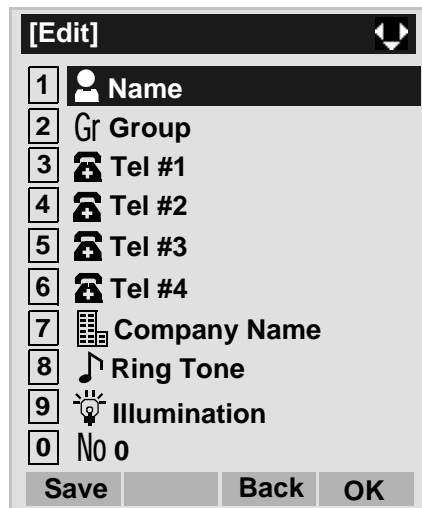

STEP 6: Enter a name to be registered in directory.



Enter a name by using digits keys. After entering the

name, press  or **OK** soft key.





Note: Up to 32 characters can be entered as a name. For details on character entry method, see [HOW TO INPUT CHARACTERS](#) in chapter 4.

STEP 7: The display goes back to the **Edit** screen. Select **2** **Group**.

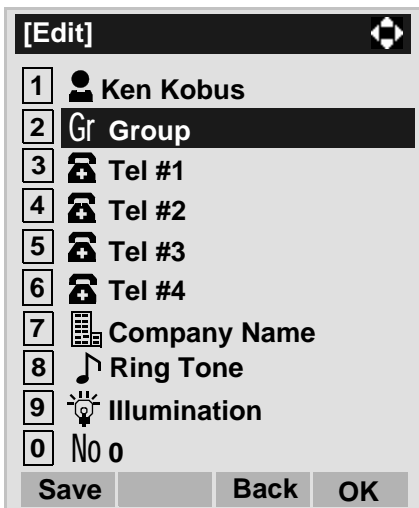
- Select an item by either of the following operations.
- Highlight an item by using , and then press ,  or **OK** soft key.
 - Press **2** key.



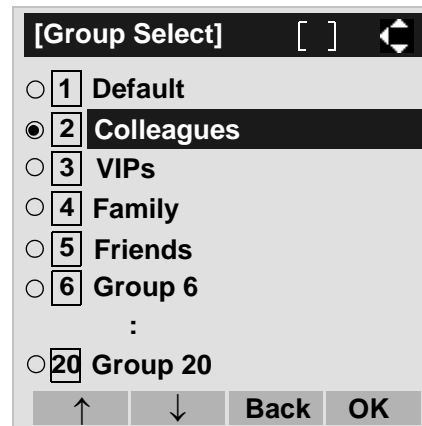

STEP 8: Select a desired group.

- Select an item by either of the following operations.
- Highlight an item by using , and then press  or **OK** soft key.
 - Press **0** - **9** key, and then press  or **OK** soft key.
- In this example, **2** **Colleagues** is selected.



Note: Each group name can be changed from the Group Setting screen. For details, see [TO CHANGE GROUP NAME](#).

STEP 9: Select **3** **Tel #1**.

- Select an item by either of the following operations.
- Highlight an item by using , and then press ,  or **OK** soft key.
 - Press **3** key.

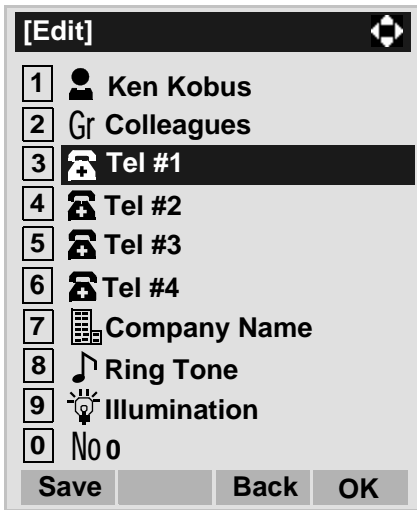

STEP 10: Enter a telephone number to be registered in directory.

Enter a telephone number by using digits keys. After entering the telephone number, press or **Next** soft key.

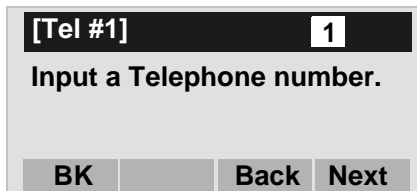

STEP 11: Select a Category to which the entered telephone number belongs.

Select an item by either of the following operations.

- Highlight an item by using , and then press

or **Next** soft key.

- Press **0** - **5** key, and then press or **Next** soft key.

In this example, **1 Company** is selected.

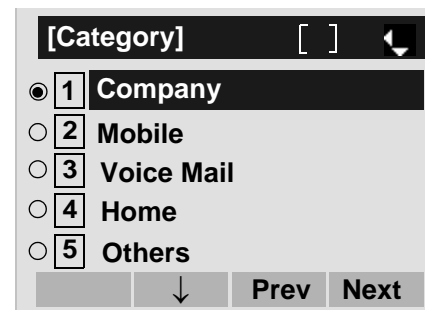

Selectable categories are as follows:

Category	ICON
Company	
Mobile	
Voice Mail	
Home	
Others	

STEP 12: Select either **1 Disable** or **2 Enable**.

Select an item by one of the following operations.

- Highlight an item by using , and then press or **OK** soft key.
- Press **1** or **2** key, and then press or **OK** soft key.

A maximum of four telephone numbers can be set to an entry. If **2 Enable** is selected here, the telephone number which is being edited will be given top priority. In that case, the telephone number is automatically selected when you make a call without specifying a specific telephone number.



STEP 13: The display goes back to the **Edit** screen again. Select **7 Company Name**.

- Select an item by either of the following operations.
- Highlight an item by using , and then press , or **OK** soft key.
 - Press **7** key.

Note: A maximum of four telephone numbers can be set to an entry. If two or more telephone numbers are required to be set, set the remaining telephone numbers to Tel #2 - Tel #4.

Note: If multiple telephone numbers are registered to an entry and Priority Flag is disabled to all of the telephone numbers, the telephone number set to Tel #1 is automatically set as first priority number.

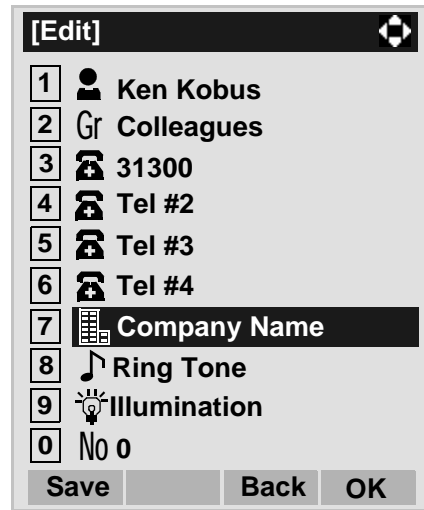

STEP 14: Enter a company name.

Enter a company name by using digits keys. After entering the company name, press or **OK** soft key.



Note: Up to 32 characters can be entered as a company name. For details on character entry method, see [HOW TO INPUT CHARACTERS](#).

STEP 15: The display goes back to the **Edit** screen. Select **8 Ring Tone**.

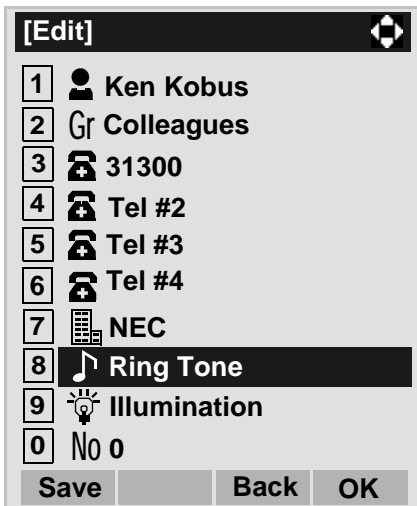

Select an item by either of the following operations.

- Highlight an item by using , and then press , or **OK** soft key.
- Press **8** key.



STEP 16: Select a desired Ringing Tone.

Select an item by either of the following operations.

- Highlight an item by using , and then press  or **OK** soft key.
- Press **0** - **9** key, and then press  or **OK** soft key.

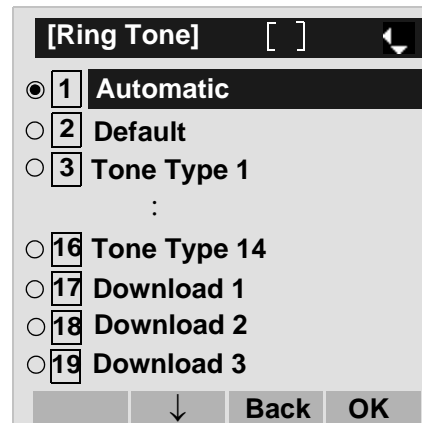



Note: You can set ringer tone for calls routed to the specified name (calling party) here. Ringer Tone type can be set for “Name”, “Group” and “Telephone set”. The ringer Tone type set for “Name” has higher priority than the types set for “Group” and “Terminal set”.

Note: Set **2 Default** when you don’t want to change the ringer tone here. The setting for “Group” or “Telephone set” is applied. Also, when **1 Automatic** is set, **3 Tone Type 1** is automatically applied.

Note: For details on each ringer tone type, see [TO SET RINGER TONE](#).

STEP 17: The display goes back to the **Edit** screen. Select **9 Illumination**.

Select an item by either of the following operations.

- Highlight an item by using , and then press , or **OK** soft key.
- Press **9** key.

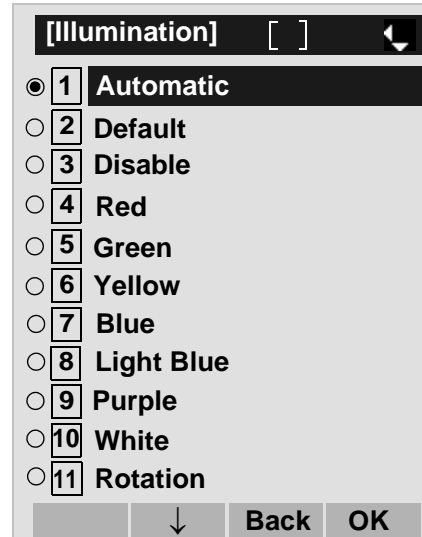
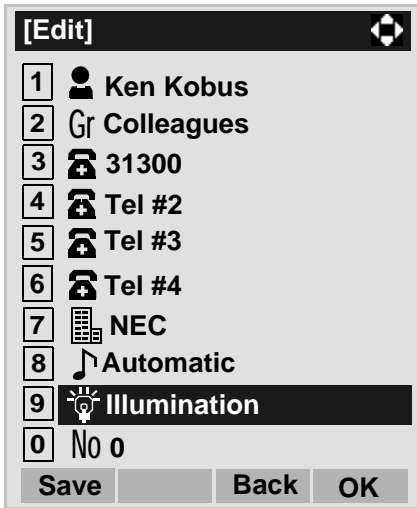

STEP 18: Select a desired color of the Call Indication lamp.

Select an item by either of the following operations.

- Highlight an item by using , and then press or **OK** soft key.
- Press **0** - **9** key, and then press or **OK** soft key.

Note: You can set illumination type for calls routed to the specified name (calling party) here. Illumination type can be set for “Name”, “Group” and “Telephone set”. The illumination type set for “Name” has higher priority than the types set for “Group” and “Terminal set”.

Note: Set **2 Default** when you don’t want to change the illumination type here. The setting for “Group” or “Telephone set” is applied. Also, when **1 Automatic** is set, **4 Red** is automatically applied.

STEP 19: The display goes back to the **Edit** screen. Check the memory number assigned to the directory data being edited.

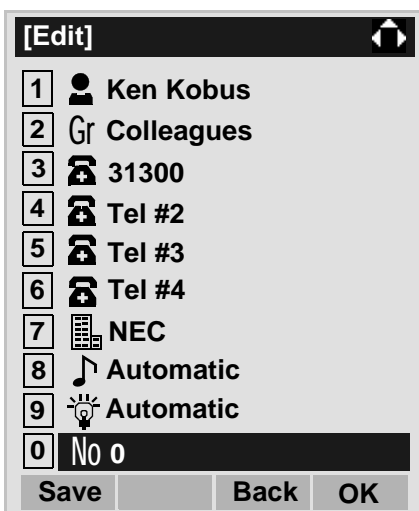

Note: A memory number is automatically set in ascending numeric order.

STEP 20: If you need to assign a memory number manually, select **0 Memory ID** on the screen of the previous step, and then enter a desired memory number (0 - 499).

Enter a memory number by using digits keys. After entering the memory number, press  or **OK** soft key.

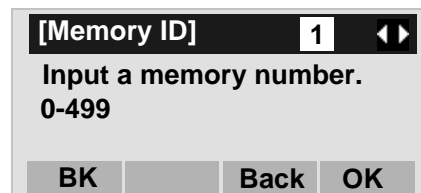

STEP 21: When the display goes back to the **Edit** screen, press **Save** soft key to save the assigned data.

STEP 22: "The data is registered at memory number: XX" is displayed. Press  key or **OK** soft key. The display returns to the **Directory** screen.

Note: If Name is not entered, "No Input Name" will appear. Name information is required for an entry.

Note: If a duplicate Memory ID is entered, "It will overwrite a data at memory number:XX" will appear. If you do not overwrite the Memory ID, press **Back** soft key. If you overwrite the Memory ID, press  or **OK** soft key.



TO CHANGE GROUP NAME **DT730**

STEP 1: Open the **Directory** screen (see [TO ADD NEW DATA](#)).

STEP 2: On the **Directory** screen, select **3 Group**

Setting.

Select an item by either of the following operations.



- Highlight an item by using , and then press ,  or **OK** soft key.
- Press **3** key.



STEP 3: Select a group name to be changed.

In this example, **1 Default** is selected.

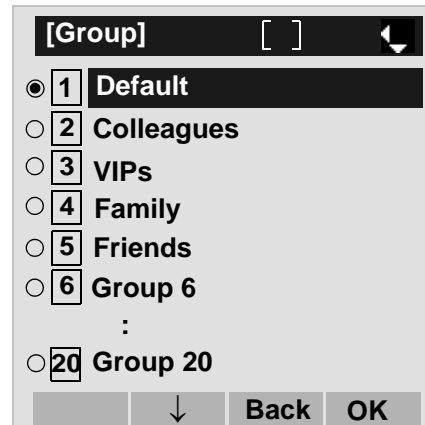

Select an item by either of the following operations.

- Highlight an item by using , and then press , or **OK** soft key.
- Press **1** key, and then press  or **OK** soft key.



STEP 4: Select **1 Name**.

Select an item by either of the following operations.

- Highlight an item by using , and then press ,  or **OK** soft key.
- Press **1** key.



STEP 5: Enter a new group name.

Enter a group name by using digits keys. After entering the group name, press  or **OK** soft key.

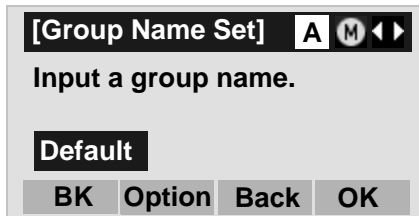

Note: Up to 32 characters can be entered as a group-name. For details on character entry method, see [HOW TO INPUT CHARACTERS](#) in chapter 4.

STEP 6: Display returns to the **Group** screen. Make sure that the new group name takes effect.

Note: You can set ringer tone (→ select 2 Ring Tone) and illumination types (→ select 3 Illumination) for calls routed to the specified group here. Ringer tone and illumination types can be set for “Name”, “Group” and “Telephone set”. The ringer tone and illumination types set for “Name” have higher priority than the types set for Group and Telephone set. Also, the ringer tone and illumination types for Group have higher priority than the types set for Terminal set.

TO FIND A REGISTERED DATA

DT730

- To Search by Group Name

STEP 1: Open the **Directory** screen (see [TO ADD NEW DATA](#)).

STEP 2: Select **1 Search** on the Directory screen.

- Select an item by either of the following operations.
- Highlight an item by using , and then press , or **OK** soft key.
 - Press **1** key.



STEP 3: Select **1 Group**.

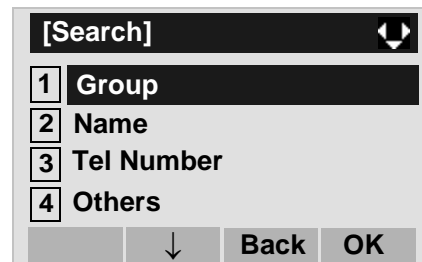

- Select an item by either of the following operations.
- Highlight an item by using , and then press , or **OK** soft key.
 - Press **1** key.





STEP 4: Select a target group.

In this example, **2 Colleagues** is selected.

Select an item by either of the following operations.

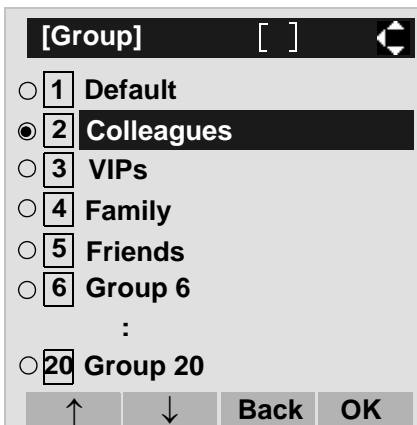
- Highlight an item by using , and then press  or **OK** soft key.
- Press **2** key, and then press  or **OK** soft key.



STEP 5: Select a target name by pressing .

In the following **Directory (Name List)** screen, you can make a call to the selected party by pressing  or **Call** soft key. If two or more telephone numbers are assigned to an entry, a top priority telephone number will be dialed.

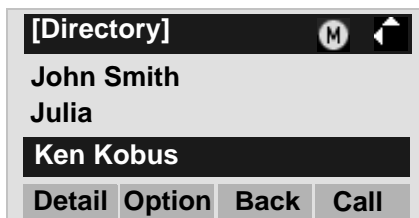

Note: If no entry is set to the selected group, "No data" is issued.

STEP 6: To display the detailed data for a specific name, press **Detail soft key while the name is highlighted.**

Note: If two or more telephone numbers are assigned to an entry, a top priority telephone number is automatically selected when the Detail screen appears.

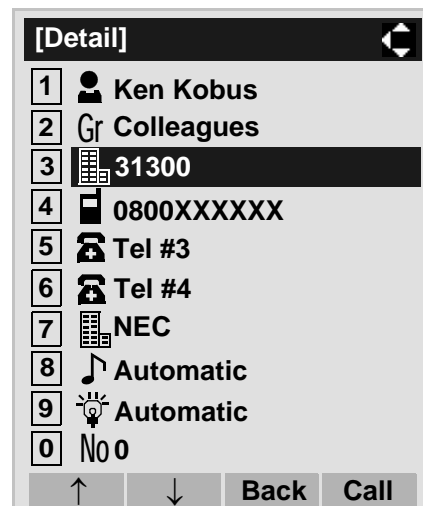

In the following **Detail** screen, you can make a call to the selected number by pressing  or **Call** soft key.



• **To Search by Name**



STEP 1: Open the **Directory** screen (see [TO ADD NEW DATA](#)).

STEP 2: Select **1 Search**.

- Select an item by either of the following operations.
- Highlight an item by using , and then press ,  or **OK** soft key.
 - Press **1** key.



STEP 3: Select **2 Name**.

- Select an item by either of the following operations.
- Highlight an item by using , and then press ,  or **OK** soft key.
 - Press **2** key.

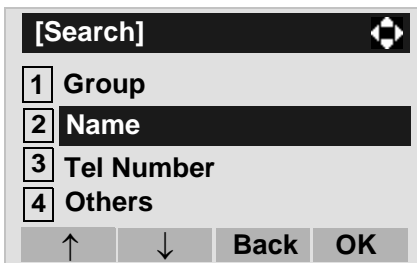

STEP 4: Enter a target name.

After entering the name, Press  or **OK** soft key.



Note: A distinction is made between upper case and lower case characters, according as the system settings. For example, "Ken Kobus" and "ken kobus" are distinguished as different character strings. For details, contact the System Administrator.

Note: A blank space is also distinguished while searching database for a name.

Note: Even if the name is not entered to the end, you can search for a name.

Note: If there is no entry corresponding to the entered name, "No data" is issued.

Note: Up to 32 characters can be entered as a company name. For details on character entry method, see [HOW TO INPUT CHARACTERS](#).

STEP 5: Select a target name by pressing  (Up/down-cursor).

In the following **Directory (Name List)** screen, you can make a call to the selected party by pressing  or **Call** soft key. If two or more telephone numbers are assigned to an entry, a top priority telephone number will be dialed.



STEP 6: To display the detailed data for a specific name, press **Detail** soft key while the name is highlighted.

Note: If two or more telephone numbers are assigned to an entry, a top priority telephone number is automatically selected when the Detail screen appears.

In the following **Detail** screen, you can make a call to the selected number by pressing  or **Call** soft key.



- **To Search by Telephone Number**

STEP 1: Open the **Directory** screen (see [TO ADD NEW DATA](#)).

STEP 2: Select **1 Search**.

- Select an item by either of the following operations.
- Highlight an item by using , and then press , or **OK** soft key.
 - Press **1** key.



STEP 3: Select **3 Tel Number**.

- Select an item by either of the following operations.
- Highlight an item by using , and then press , or **OK** soft key.
 - Press **3** key.

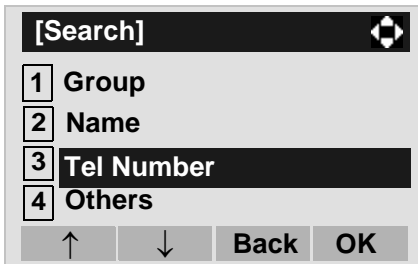

STEP 4: Enter a target telephone number.

After entering the number, press or **OK** soft key.



Note: Even if the telephone number is not entered to the end, you can search for a telephone number.

STEP 5: Select a target name by pressing .

In the following **Directory (Name List)** screen, you can make a call to the selected party by pressing or **Call** soft key. If two or more telephone numbers are assigned to an entry, a top priority telephone number will be dialed.



Note: If there is no entry corresponding to the entered number, "No data" is issued on the screen.

STEP 6: To display the detailed data for a specific name, press **Detail** soft key while the name is highlighted.

Note: If two or more telephone numbers are assigned to an entry, a top priority telephone number is automatically selected when the Detail screen appears.



In the following **Detail** screen, you can make a call to the selected number by pressing  or **Call** soft key.



• **To Search by Memory ID**



STEP 1: Open the **Directory** screen (see [TO ADD NEW DATA](#)).

STEP 2: Select **1 Search**.

- Select an item by either of the following operations.
- Highlight an item by using , and then press , or **OK** soft key.
 - Press **1** key.



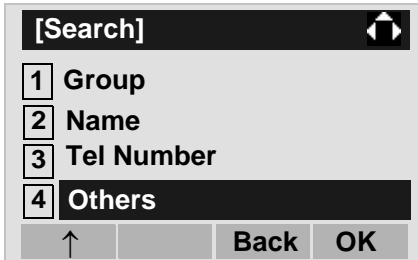

STEP 3: Select **4 Others**.

- Select an item by either of the following operations.
- Highlight an item by using , and then press , or **OK** soft key.
 - Press **4** key.



STEP 4: Select **1 Memory ID**.

- Select an item by either of the following operations.
- Highlight an item by using , and then press , or **OK** soft key.
 - Press **1** key.

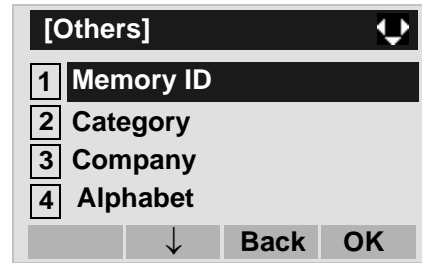



STEP 5: Enter a memory number (0-499).

After entering the memory number, press  or **OK** soft key.

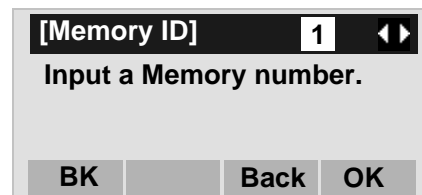
The list of memory numbers will be displayed, with the entered memory number or the number closest to the entered number in front.



STEP 6: Select a target name by pressing  (Up/down-cursor).

In the following **Directory (Name List)** screen, you can make a call to the selected party by pressing  or **Call** soft key. If two or more tele-

phone numbers are assigned to an entry, a top priority telephone number will be dialed.

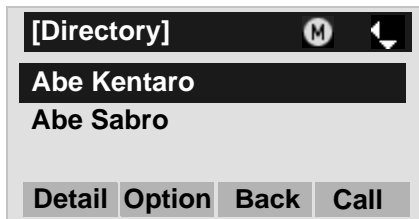

Note: If no data exists in Directory, "No data" is issued on the screen.

STEP 7: To display the detailed data for a specific name, press **Detail** soft key while the name is highlighted.

Note: If two or more telephone numbers are assigned to an entry, a top priority telephone number is automatically selected when the Detail screen appears.



In the following **Detail** screen, you can make a call to the selected number by pressing  or **Call** soft key.



• **To Search by Category**



STEP 1: Open the **Directory** screen (see [TO ADD NEW DATA](#)).

STEP 2: Select **1 Search**.

- Select an item by either of the following operations.
- Highlight an item by using , and then press , or **OK** soft key.
 - Press **1** key.



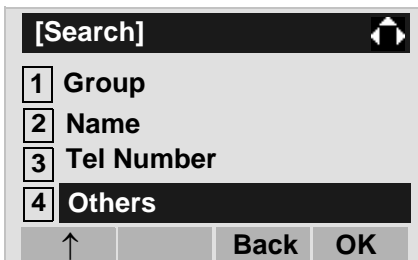

STEP 3: Select **4 Others**.

- Select an item by either of the following operations.
- Highlight an item by using , and then press , or **OK** soft key.
 - Press **4** key.



STEP 4: Select **2 Category**.

- Select an item by one of the following operations.
- Highlight an item by using , and then press , or **OK** soft key.
 - Press **2** key.

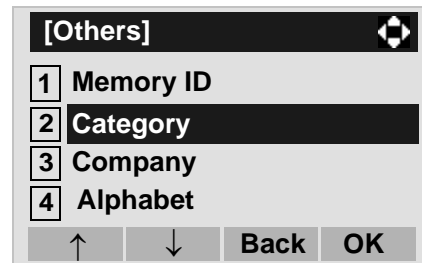

STEP 5: Select a desired category.

- In this example, **1 Company** is selected.
- Select an item by one of the following operations.
- Highlight an item by using , and then press , or **OK** soft key.
 - Press **1** key, and then press  or **OK** soft key.

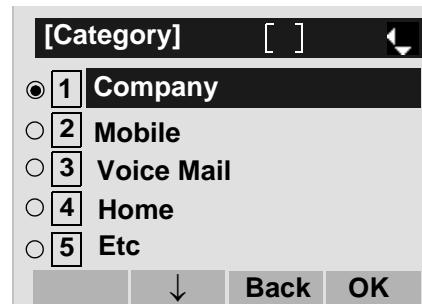

STEP 6: Select a target name by pressing .

In the following **Directory (Name List)** screen, you can make a call to the selected party by pressing  or **Call** soft key. If two or more tele-

phone numbers are assigned to an entry, a top priority telephone number will be dialed.



Note: If there is no entry corresponding to the selected category, "No data" is issued on the screen.

STEP 7: To display the detailed data for a specific name, press **Detail** soft key while the name is highlighted.

Note: If two or more telephone numbers are assigned to an entry, a top priority telephone number is automatically selected when the Detail screen appears.



In the following **Detail** screen, you can make a call to the selected number by pressing  or **Call** soft key.



- **To Search by Company Name**



STEP 1: Open the **Directory** screen (see [TO ADD NEW DATA](#)).

STEP 2: Select **1 Search**.

- Select an item by either of the following operations.
- Highlight an item by using , and then press , or **OK** soft key.
 - Press **1** key.



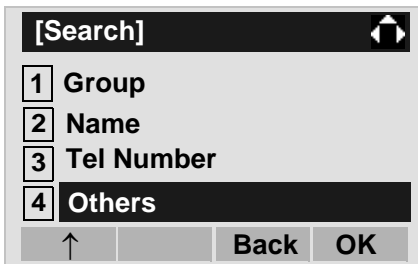

STEP 3: Select **4 Others**.

- Select an item by either of the following operations.
- Highlight an item by using , and then press , or **OK** soft key.
 - Press **4** key.



STEP 4: Select **3 Company**.

- Select an item by either of the following operations.
- Highlight an item by using , and then press , or **OK** soft key.
 - Press **3** key.

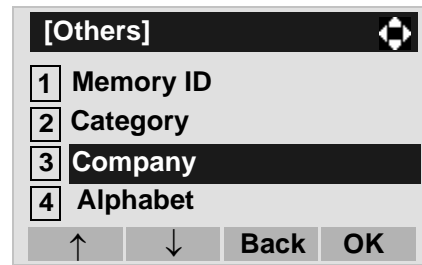



STEP 5: Enter a company name.

After entering the name, Press  or **OK** soft key.



- Note:** A distinction is made between upper case and lower case characters. For example, "Ken Kobus" and "ken kobus" are distinguished as different character strings.
- Note:** A blank space is also distinguished while searching database for a name.
- Note:** Even if the name is not entered to the end, you can search for a name.
- Note:** Up to 32 characters can be entered as a company name. For details on character entry method, see [HOW TO INPUT CHARACTERS](#).

STEP 6: Select a target name by pressing .

In the following **Directory (Name List)** screen, you can make a call to the selected party by pressing  or **Call** soft key. If two or more telephone numbers are assigned to an entry, a top priority telephone number will be dialed.



Note: If there is no entry corresponding to the selected Company, "No data" is issued on the screen.

STEP 7: To display the detailed data for a specific name, press **Detail** soft key while the name is highlighted.

Note: If two or more telephone numbers are assigned to an entry, a top priority telephone number is automatically selected when the Detail screen appears.



In the following **Detail** screen, you can make a call to the selected number by pressing  or **Call** soft key.



- **To Search by Alphabet**



STEP 1: Open the **Directory** screen (see [TO ADD NEW DATA](#)).

STEP 2: Select **1 Search**.

- Select an item by either of the following operations.
- Highlight an item by using , and then press , or **OK** soft key.
 - Press **1** key.



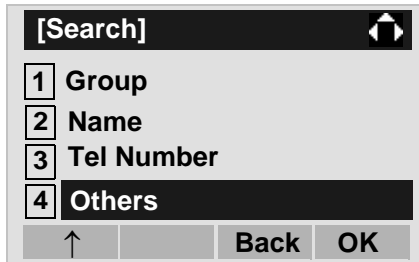

STEP 3: Select **4 Others**.

- Select an item by either of the following operations.
- Highlight an item by using , and then press , or **OK** soft key.
 - Press **4** key.



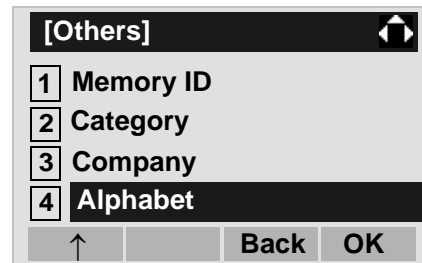

STEP 4: Select **4 Alphabet**.

- Select an item by either of the following operations.
- Highlight an item by using , and then press , or **OK** soft key.
 - Press **4** key.



STEP 5: Select a **desired group of alphabets**.

- In this example, **1 ABC** is selected.
- Select an item by one of the following operations.
- Highlight an item by using , and then press , or **OK** soft key.
 - Press **0** key, and then press  or **OK** soft key.



Note: Select * **Others** to find names which begin with a character other than alphabet such as numerics or symbols.

STEP 6: Select a target name by pressing . In the following **Directory (Name List)** screen, you can make a call to the selected party by pressing or **Call** soft key. If two or more telephone numbers are assigned to an entry, a top priority telephone number will be dialed.



Note: If there is no entry corresponding to the group of alphabets, "No data" is issued on the screen.

STEP 7: To display the detailed data for a specific name, press **Detail** soft key while the name is highlighted.

Note: If two or more telephone numbers are assigned to an entry, a top priority telephone number is automatically selected when the Detail screen appears.

In the following **Detail** screen, you can make a call to the selected number by pressing or **Call** soft key.



TO MAKE A CALL FROM DIRECTORY



DT730

Note: While Directory screen is being displayed, you cannot make a call by dialing a telephone number.

- **To Make a Call from Name List Screen**

STEP 1: Display the **Directory (Name List)** screen for a target party (see [TO FIND A REGISTERED DATA](#)).



STEP 2: Select a target name and then make a call. Select a target name by pressing , and then press  or **Call** soft key to make a call to the selected party.



Note: If multiple telephone numbers are registered to a target party, a call is made to the first priority telephone number.



- **To Make a Call from Detail Screen**

STEP 1: Display the **Detail** screen for a target party (see [TO FIND A REGISTERED DATA](#)).

Note: If two or more telephone numbers are assigned to an entry, a top priority telephone number is automatically selected when the Detail screen appears.



STEP 2: Select a target telephone number and then make a call.

Select a target telephone number by pressing , and then press  or **Call** soft key to make a call to the selected number.



- Press **5** key.

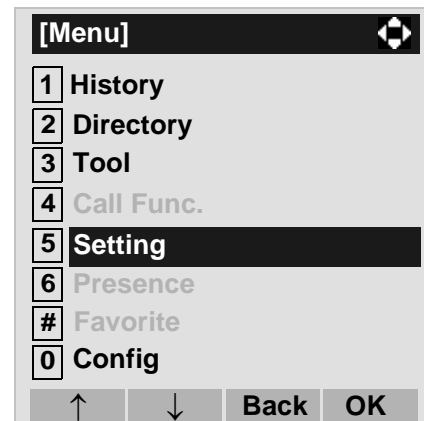

STEP 3: Select **1** **User Setting**.

- Select an item by either of the following operations.
- Highlight an item by using and then press , or **OK** soft key.
 - Press **1** key.

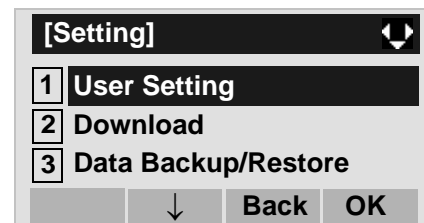

STEP 4: Select **2** **Talk**.

- Select an item by either of the following operations.
- Highlight an item by using and then press , or **OK** soft key.
 - Press **2** key.

TO ADD PREFIX TO NUMBER **DT730**

• To Set Prefix

When making a call, a prefix can be added to telephone numbers to be dialed. Prefixes need to be set in advance.

STEP 1: While indicating the current time on LCD, press key to open the **Menu** screen.

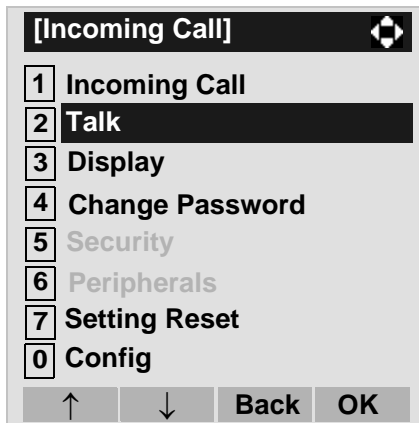

STEP 2: Select **5** **Setting** on the Menu screen.

- Select an item by either of the following operations.
- Highlight an item by using , and then press , or **OK** soft key.



STEP 5: Select 5 Prefix.



Select an item by either of the following operations.

- Highlight an item by using , and then press ,  or **OK** soft key.
- Press 5 key.



STEP 6: Select 1 Prefix 1.

Select an item by either of the following operations.

- Highlight an item by using , and then press ,  or **OK** soft key.
- Press 1 key.



STEP 7: Enter a prefix by using the digit keys.

After entering the prefix, press  or **OK** soft key.

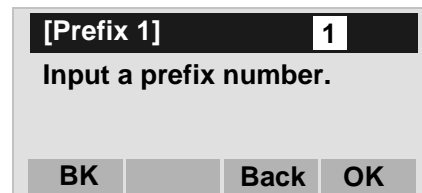

STEP 8: The display goes back the Prefix screen at STEP 5. If multiple prefixes need to be set, repeat STEP 6 and STEP 7. In that case, select 2 Prefix 2 and 3 Prefix 3.

Note: A maximum of 10 digits (0-9, * and #) can be set as a prefix.

Note: When prefix is added, up to 32 digits including the prefix can be sent as dial number.

• **To Add Prefix When Making A Call**

STEP 1: Display the **Name List** screen for a target party (see [TO FIND A REGISTERED DATA](#)).



STEP 2: Select a target name and display Sub Menu. Select a target name by pressing , and then press key or **Option** soft key.



Note: If multiple telephone numbers are registered to a target party, a call is made to the first priority telephone number.

STEP 3: Select **1 Prefix**.

- Select an item by one of the following operations.
- Highlight an item by using , and then press , or **OK** soft key.
 - Press **1** key, and then press , or **OK** soft key.



STEP 4: Predetermined prefixes are displayed. Select a prefix and then press or **OK** soft key to make a call.

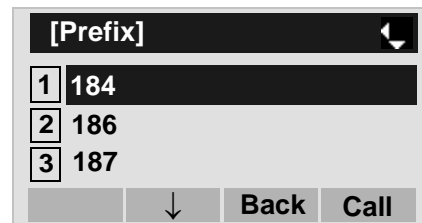



TO EDIT DIRECTORY DATA DT730

STEP 1: Display the **Name List** screen for a target party (see [TO FIND A REGISTERED DATA](#)).





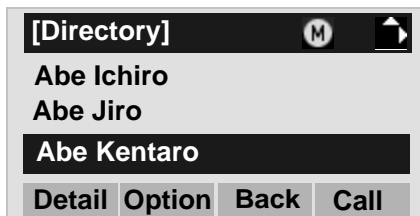

STEP 2: Select a target name and display Sub Menu.

Select a target name by pressing , and then press  key or **Option** soft key.



STEP 3: Select **4 Edit**.

Select an item by one of the following operations.

- Highlight an item by using , and then press , , or **OK** soft key.
- Press **4** key, and then press , , or **OK** soft key.

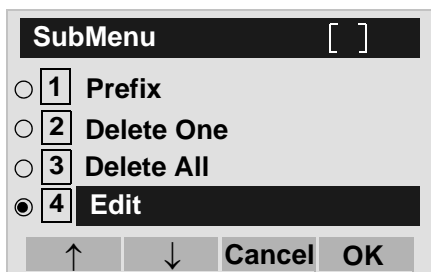

STEP 4: On the **Edit** screen, the detailed data for the selected name is displayed. Modify the necessary data by referring to [TO ADD NEW DATA](#).

After the data modification is complete, press **Save** soft key on the Edit screen.



TO DELETE ALL DATA **DT730**

STEP 1: Open the **Directory** screen (see [TO ADD NEW DATA](#)).

STEP 2: Select **0 Delete All**.

Select an item by either of the following operations.

- Highlight an item by using , and then press , , or **OK** soft key.
- Press **0** key.



STEP 3: Press or **OK** soft key to delete all the data.



Note: To cancel the data deletion, press or **Back** soft key.

STEP 4: After all the directory data is deleted, the display changes as follows:



STEP 5: Press or **OK** soft key.

TO DELETE A SPECIFIC DATA **DT730**

STEP 1: Display the **Name List** screen for a target party (see [TO FIND A REGISTERED DATA](#)).



STEP 2: Select a name to be deleted and display Sub Menu.

Select a target name by pressing , and then press key or **Option** soft key.



STEP 3: Select **[2] Delete One**.

Select an item by either of the following operations.

- Highlight an item by using , and then press , or **OK** soft key.
- Press **[2]** key, and then press , or **OK** soft key

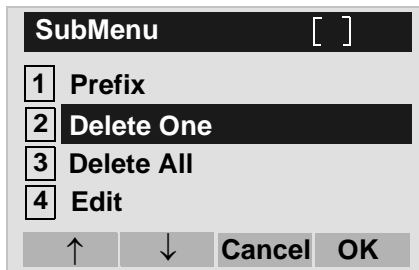

STEP 6: Press  or **OK** soft key.

STEP 4: The following confirmation message appears. Press  or **OK** soft key to delete the appropriate directory data.



Note: To cancel the data deletion, press  or **Cancel** soft key.

STEP 5: After the appropriate directory data is deleted, the display changes as follows:

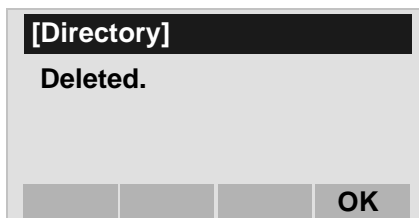

7. CALL HISTORY OPERATION

This chapter explains the Call History feature of DT Series. By using Call History, you can make a call with simple operation.

Call History feature allows the telephone to register up to 50 records (for DT730 Series)/10 records (for DT330 Series) into its memory. If exceeding 50 records/10 records, a record will be deleted in order of occurrence.

FOR DT730 SERIES

- TO VIEW CALL HISTORY
- TO MAKE A CALL FROM CALL HISTORY
- TO ADD CALL HISTORY DATA TO DIRECTORY
- TO EDIT DIRECTORY DATA FROM CALL HISTORY
- TO DELETE ALL DATA
- TO DELETE A SPECIFIC DATA

FOR DT330 SERIES

- TO VIEW CALL HISTORY
- TO MAKE A CALL FROM CALL HISTORY
- TO DELETE ALL DATA
- TO DELETE A SPECIFIC DATA

Note: Register call history data to Personal Directory as necessary. Call History data will be cleared when powering off the telephone. However, call history data can be backed up to your PC. About Backup/Restore, see “TO BACKUP PERSONAL SETTINGS” or “TO RESTORE PERSONAL SETTINGS” in “3.TERMINAL SETUP”.

Note: The call history data that is stored in the memory of each telephone cannot be added to Phonebook (both System Phonebook and Local Phonebook) controlled by the system.

7.1 FOR DT730 SERIES

TO VIEW CALL HISTORY **DT730**

STEP 1: While indicating the current time on LCD, press **Menu** key to open the **Menu** screen.

Note: This feature is available for DT730 Series. DT710 Series does not support this feature. The following are examples of LCD display of DT730 Series.

DT730 Series

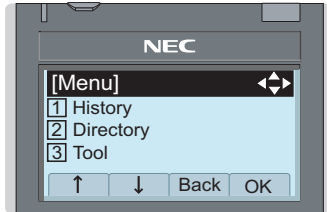

STEP 2: Select **1 History**.

- Select an item by either of the following operations.
- Highlight an item by using **Up** or **Down** arrow keys, and then press **OK** soft key.
 - Press **1** key.



STEP 3: Select a kind of calls.

In this example, **3 Incoming** is selected.

- Select an item by either of the following operations.
- Highlight an item by using **Up** or **Down** arrow keys, and then press **OK** soft key.
 - Press **3** key.

Item	Description
Missed	Display the history of unanswered incoming calls.
Outgoing	Display the history of outgoing calls.
Incoming	Display the history of answered and unanswered incoming calls.



STEP 4: The history data of the last received call is displayed.

If two or more records exist, use  or \uparrow/\downarrow soft key to display the next/former records.



Note: For unanswered incoming calls,  will be displayed on the left of the name.

Note: If you make/answer a call to/from the telephone number which is registered to Personal Directory, the corresponding name will be displayed as call history data.

Note: If there is no history data, "No data" will be displayed on LCD.

Note: To go back to former menu (STEP 3), press  or **Back** soft key.

TO MAKE A CALL FROM CALL HISTORY **DT730**

Note: While the history data is displayed, you cannot make a call by dialing a telephone number.

(CASE 1)

STEP 1: Display call history data of a target telephone number (see [TO VIEW CALL HISTORY](#)).

The following is an example when a history data of Incoming Calls is displayed.

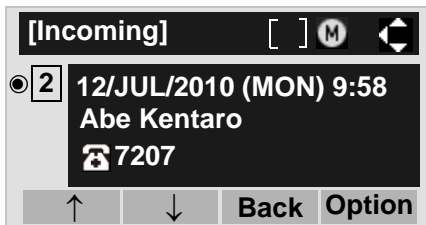

STEP 2: Press  key to make a call to the telephone number.

(CASE 2)



STEP 1: Display call history data of a target telephone number (see [TO VIEW CALL HISTORY](#)).

The following is an example when a history data of Incoming Calls is displayed.

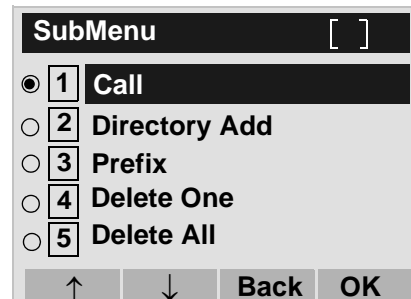

STEP 2: On the above screen, press  key or **Option** soft key to display the following Sub Menu.



STEP 3: To make a call, select **1 Call** (by using  or pressing **1** key) and then press , , or **OK** soft key.

Note: When making a call from Call History, a prefix can be added to the dial number. In that case, select **3 Prefix** on the SubMenu (indicated at STEP 2 of CASE 2) to display the Prefix screen. On the Prefix screen, choose a prefix to be added to the dial number. Also, prefixes need to be set in advance. For details on setting of prefix, see [TO ADD PREFIX TO NUMBER](#) in Chapter 6 Directory Operation.

TO ADD CALL HISTORY DATA TO DIRECTORY **DT730**

STEP 1: Display call history data of a target telephone number (see [TO VIEW CALL HISTORY](#)).

The following is an example when history data of an Incoming Call is displayed.



Press **Menu** key or **Option** soft key while displaying the call history data for the target telephone number.

STEP 2: The following Sub Menu is displayed. Select **2 Directory Add**.

- Select an item by either of the following operations.
- Highlight an item by using , and then press , or **OK** soft key.
 - Press **2** key, and then press , or **OK** soft key

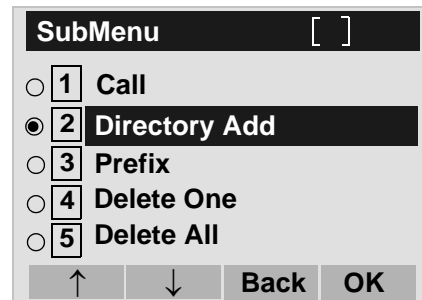

STEP 3: Select **1 New**.

- Select an item by either of the following operations.
- Highlight an item by using , and then press , or **OK** soft key.
 - Press **1** key.



STEP 4: Select a category.

- In this example, **1 Company** is selected.
- Select an item by either of the following operations.
- Highlight an item by using , and then press , or **Next** soft key.
 - Press **1** key, and then press or **Next** soft key.

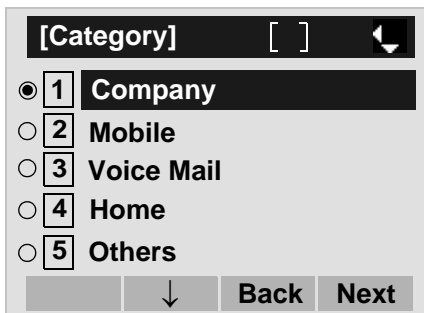

Selectable categories are as follows:

Category	ICON
Company	
Mobile	
Voice Mail	
Home	
Others	

STEP 5: Select either **1 Disable** or **2 Enable**.

A maximum of four telephone numbers can be set to an entry. If **2 Enable** is selected here, the telephone number which is being edited will be given top priority. In that case, the telephone number is automatically selected when you make a call without specifying a specific telephone number.

Select an item by either of the following operations.

- Highlight an item by using , and then press or **OK** soft key.

- Press **1** or **2** key, and then press or **OK** soft key.



STEP 6: The following **Edit** screen is displayed.

“31312” has been registered to Tel #1.

See **“TO ADD NEW DATA”** in Chapter 6 Directory Operation, and register detailed data (such as name, group, etc) to directory.

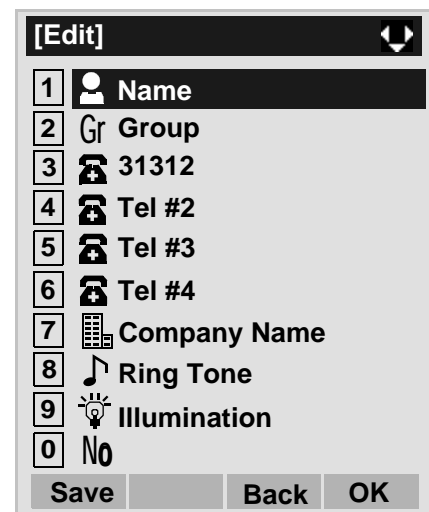

Note: If the corresponding data is not stored in the directory, only the telephone number will be displayed as Tel #1.

Note: If the corresponding data has already stored in the directory, the detailed data (such as name group, etc.) is displayed.

TO EDIT DIRECTORY DATA FROM CALL HISTORY **DT730**

STEP 1: Display call history data of a target telephone number (see [TO VIEW CALL HISTORY](#)).

The following is an example when history data of an Incoming Call is displayed.



Press **Menu** key or **Option** soft key while displaying the call history data for the target telephone number.

STEP 2: The following Sub Menu is displayed. Select **2 Directory Add**.

- Select an item by either of the following operations.
- Highlight an item by using , and then press , or **OK** soft key.
 - Press **2** key, and then press , or **OK** soft key

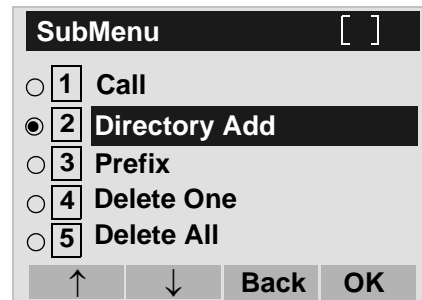

STEP 3: Select **2 Addition**.

- Select an item by either of the following operations.
- Highlight an item by using , and then press , or **OK** soft key.
 - Press **2** key.

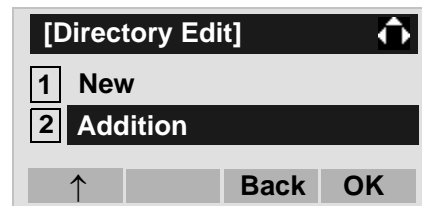

STEP 4: Select a search method.

See [TO FIND A REGISTERED DATA](#) for the procedure of the searching method.

In this example, **1 Group** is selected.

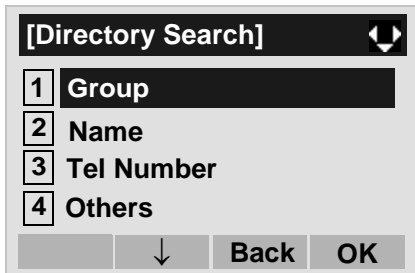

- Select an item by either of the following operations.
- Highlight an item by using , and then press , or **OK** soft key.
 - Press **1** key.



STEP 5: Select a group.

In this example, **2 Colleagues** is selected.

Select an item by either of the following operations.

- Highlight an item by using , and then press  or **OK** soft key.
- Press **2** key, and then press  **OK** soft key

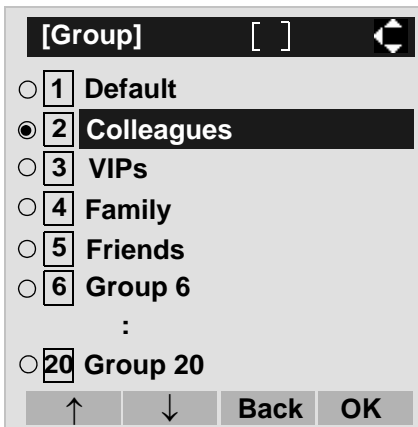

STEP 6: The names belonging to Colleagues are displayed as the following example.



Select a name and then press  or **OK** soft key.



Note: If there is no corresponding data, "No data" will be displayed on LCD.

STEP 7: Select a registration destination. In this example, "7205" will be added to Tel #2.

Select an item by either of the following operations.

- Highlight an item by using , and then press  or **OK** soft key.
- Press **1** - **4** key, and then press  or **OK** soft key.

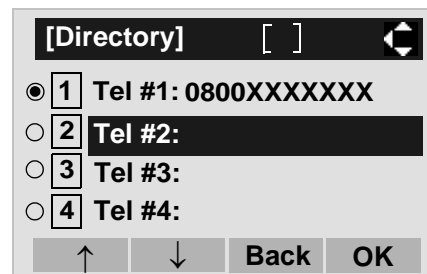



Note: In this example, a mobile telephone number "0800XXXXXXX" has already been registered to Tel #1. If you select Tel #1 here, "0800XXXXXXX" will be overwritten with "7205".

STEP 8: Select a Category to which the telephone number belongs.

In this example, **1 Company** is selected.

Select an item by either of the following operations.



- Highlight an item by using , and then press  or **OK** soft key.
- Press **1** key, and then press  or **OK** soft key.



STEP 9: Select either **1 Disable** or **2 Enable**.

A maximum of four telephone numbers can be set to an entry. If **2 Enable** is selected here, the telephone number which is being edited will be given top priority. In that case, the telephone number is automatically selected when you make a call without specifying a specific telephone number.

Select an item by either of the following operations.

- Highlight an item by using , and then press  or **OK** soft key.
- Press **1** or **2** key, and then press  or **OK** soft key.

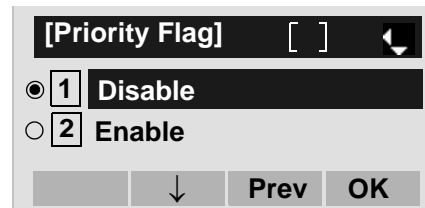

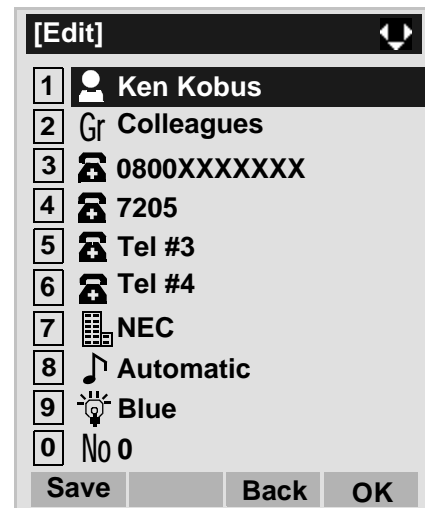

STEP 10: The display moves to the **Edit** screen of Directory. "7205" has been registered to Tel #2. See [TO EDIT DIRECTORY DATA](#) in Directory Operation, and edit the data as necessary.



TO DELETE ALL DATA **DT730**



STEP 1: While indicating the current time on LCD, press **Menu** key to open the **Menu** screen.

STEP 2: Select **1 History**.

- Select an item by either of the following operations.
- Highlight an item by using , and then press , or **OK** soft key.
 - Press **1** key.



STEP 3: Select **4 All Delete**.

- Select an item by either of the following operations.
- Highlight an item by using , and then press , or **OK** soft key.
 - Press **4** key.

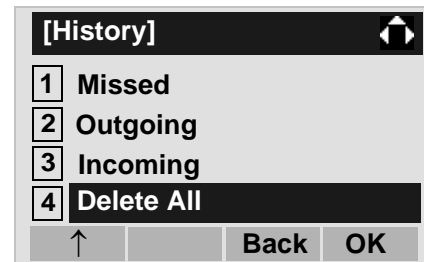

STEP 4: The following confirmation message appears. Press  or **OK** soft key to delete all the data.

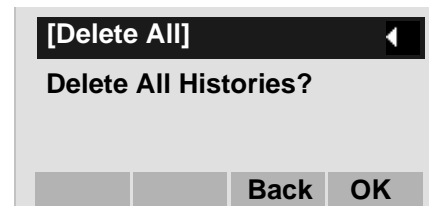

Note: To cancel the data deletion, press  or **Back** soft key.

STEP 5: After all history data is deleted, the display changes as follows. Press  or **OK** soft key.

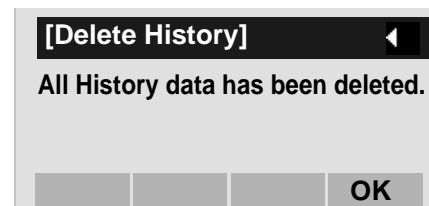

TO DELETE A SPECIFIC DATA **DT730**

STEP 1: Display call history data of a target telephone number referring to [TO VIEW CALL HISTORY](#).

The following is an example when a history data of Incoming Calls is displayed.



Press **Menu** key or **Option** soft key while displaying the call history data for the target telephone number.

STEP 2: The following Sub Menu is displayed. Select **4 Delete One**.

Select an item by either of the following operations.

- Highlight an item by using **Up** or **Down** arrow keys, and then press **OK** soft key.
- Press **4** key, and then press **Up**, **Down** or **OK** soft key.

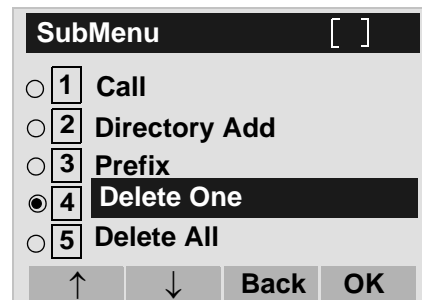

Note: By selecting **5 Delete All**, all records of Incoming Call can be deleted.

STEP 3: The following confirmation message appears. Press **OK** or **OK** soft key to delete the appropriate history data.

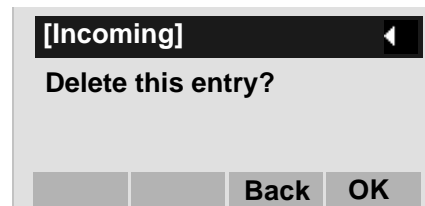

Note: To cancel the data deletion, press **Back** or **Back** soft key.

STEP 4: After the appropriate call history data is deleted, the display changes as follows. Press  or **OK** soft key.

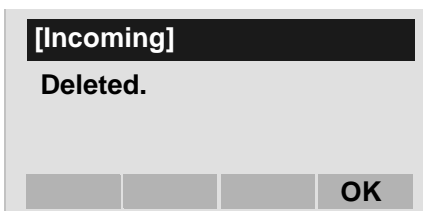

7.2 FOR DT330 SERIES

TO VIEW CALL HISTORY **DT330**

- TO VIEW DATA OF INCOMING CALL/ OUTGOING CALL



STEP 1: While indicating the current time on LCD, press  key to open the **Menu** screen.

Note: This feature is DT730 Series and DT330 Series. The following are examples of LCD displays of DT730 Series and DT330 Series.

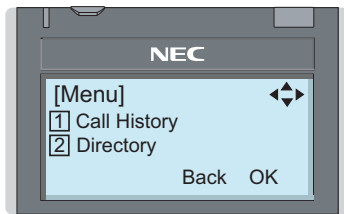
DT330 Series



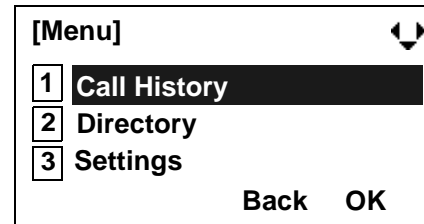

STEP 2: Select **1 Call History**.

- Select an item by either of the following operations.
- Highlight an item by using , and then press ,  or **OK** soft key.
 - Press **1** key.



STEP 3: Select a kind of calls.

In this example, **1 Incoming Calls** is selected. Select an item by either of the following operations.

- Highlight an item by using , and then press ,  or **OK** soft key.
- Press **1** key.

Item	Description
Incoming Calls	To view the history of incoming calls.
Outgoing Calls	To view the history of outgoing calls.

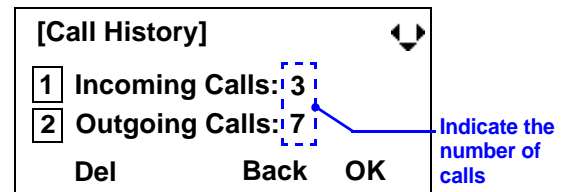

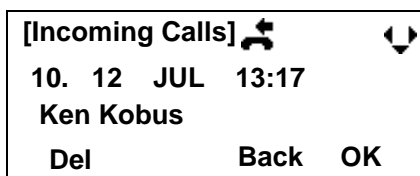

STEP 4: The history data of the last received call is displayed. If name information of the caller exists, the name is displayed as follows:

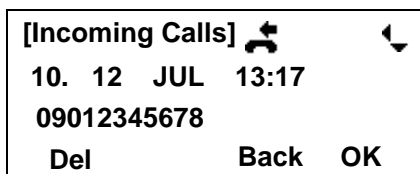

Note: There are two types of incoming call: Answered Call and Missed Call. When history data of missed calls is displayed on the screen,  appears on the top line of the screen.

STEP 5: To view the telephone number of the caller, press .



Note: If two or more records exist, use  to display the next/former records (or pressing an appropriate digit key). For example, press "0" key to display the tenth record.

Note: If no history data is saved, "No data" will be displayed on LCD.

Note: To go back to name display, press  key. For the telephone without the cursor key, switching between "name" and "telephone number" cannot be performed.

Note: To go back to former menu (STEP 3), press **Back** soft key.

Note: If the telephone number of the caller is not received (due to Caller ID blocking, public phone or out of area, etc.), "Private" is displayed on LCD.

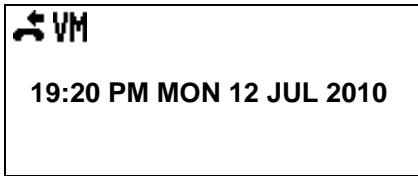

• **TO VIEW DATA OF MISSED CALL ONLY**

STEP 1: While indicating the current time on LCD, press  key to open **Shortcut** screen.



Note:  indicate that the telephone has received a missed call.
VM indicate that the telephone has received a voice mail.

STEP 2: Select **1 Missed Calls**.
 Select an item by either of the following operations.

- Highlight an item by using , and then press ,  or **OK** soft key.
- Press **1** key.

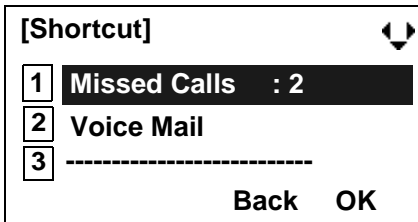

Note: When voice mail service is not used, "**2** -----" is displayed instead of "**2** Voice Mail".

STEP 3: The history data of the last received call is displayed. If name information of the caller exists, the name is displayed as follows:

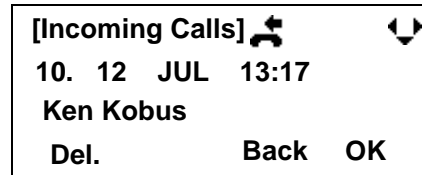

Note: If two or more records exist, use  key to display the next/former records (or pressing an appropriate digit key). For example, press "0" key to display the tenth record.

Note: To go back to former menu (STEP 3), press **Back** soft key.

Note: If the telephone number of the caller is not received (due to Caller ID blocking, public phone or out of area, etc.), "Private" is displayed on LCD.

TO MAKE A CALL FROM CALL HISTORY **DT330**

STEP 1: Display the call history data of the target telephone number (see [TO VIEW CALL HISTORY](#)).

The following is an example when the history data of an incoming call is displayed.

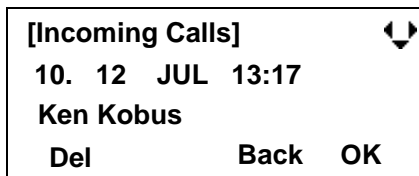



STEP 2: Press  key while the history data for the target telephone number is displayed on LCD.

Note: While the history data is displayed, you cannot make a call by dialing a telephone number.



TO DELETE ALL DATA DT330

STEP 1: Select **1** **Call History** on the Menu screen.

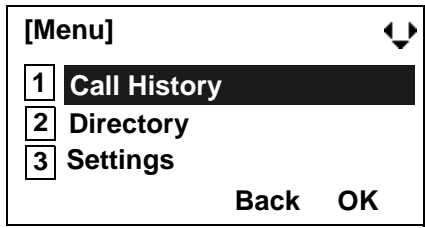
- Select an item by either of the following operations.
- Highlight an item by using , and then press ,  or **OK** soft key.
 - Press **1** key.



STEP 2: Select a kind of calls.

- In this example, **1** **Incoming Calls** is selected.
- Select an item by either of the following operations.
- Highlight an item by using , and then press ,  or **OK** soft key.
 - Press **1** key.

Item	Description
Incoming Calls	To delete all the history data of incoming calls.
Outgoing Calls	To delete all the history data of outgoing calls.

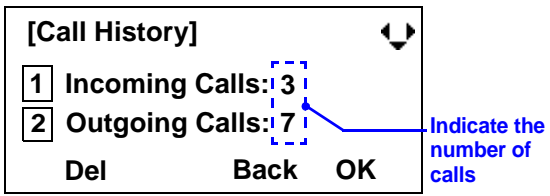

STEP 3: Press **Del** soft key. The display changes as follows:

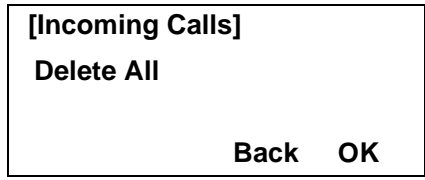

Note: To cancel the data deletion, press  or **Back** soft key.

STEP 4: Press  or **OK** soft key to delete all the history data of selected call type.

TO DELETE A SPECIFIC DATA **DT330**

STEP 1: Display the call history data which you want to delete (see [TO VIEW CALL HISTORY](#)). The following is an example when the history data of an incoming call is displayed.

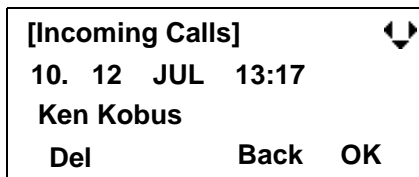

STEP 2: Press **Del** soft key. The display changes as follows:

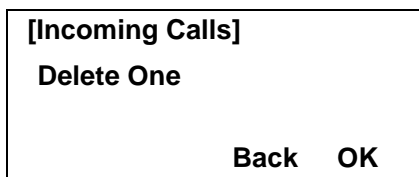

Note: To cancel the data deletion, press  or **Back** soft key.

STEP 3: Press  or **OK** soft key to delete the selected history data.

This page is for your notes.

8. SPECIFICATIONS

TECHNICAL SPECIFICATIONS

The following shows the technical specifications of DT 300 Series.

Telephone Type	8LD	32D	24D/12D	6DE	2E
Display (LCD)	87 × 43mm, 168 × 58 dot matrix, 28-digit 4-line * 8LD has two LCDs.			90 × 28mm, 24-digit × 3-line	None
Display Color	Monochrome (with no shades of gray)				-
Character on LCD	Characters supported by Multilingual Display (Note 1)				-
Programmable Key	Key data is displayed on LCD. 32 (8 X 4) Keys [2-color (red and green) LED]	32/24/12 Keys [2-color (red and green) LED]		6 Keys [2-color (red and green) LED]	2 Keys
Fixed Feature Key	10 keys (with Menu/Cursor button) (Note 2)			12 Keys	12 Keys
Backlight	Display and Digit Key (lit for 10 seconds when operating) *For 32D/24D/12D, Display Backlight is optional.			None	
Soft Key	4 Keys				None
Call History	Outgoing Call: 10 record, Incoming Call: 10 records			None	
Hands-free	Standard equipment (Full-duplex)			Standard equipment (Half-duplex)	
Headset	Available			Not available	
Power Consumption	2.2 [W]			1.2 [W]	
Adapter (optional)	Recording Unit (ADA)/Analog Port Unit (APR)/Wall-mounting kit (WM)/Digit-key Set Unit/Key kit/Side panel			Side panel	
Color	Black/White			Black	
Dimension (W×D×H)	179(W) × 248.7(D) × 111.7(H) [mm]			179(W) × 257(D) × 112(H) [mm]	
Weight	1.3 kg	1.2 kg	1.2 kg	1.1 kg	1.0 kg

Note 1: 6DE does not support the display in Russian.

Note 2: Optional Retro key kit supplies 12 Fixed Feature Keys

The following shows the technical specifications of DT 700 Series.

Telephone Type	8LD	32D	24D/12D	6DE	2E
Display (LCD)	87 × 43mm, 224 × 96 dot matrix, 28-digit 5-line * 8LD has two LCDs.			90 × 28mm, 168 × 41 dot matrix, 24-digit × 3-line	None
Display Color	Gray scale (with 8 shades of gray)			Monochrome (with no shades of gray)	-
Programmable Key	Key data is displayed on LCD. 32 (8 X 4) Keys [2-color (red and green) LED]	32/24/12 Keys [2-color (red and green) LED]		6 Keys [2-color (red and green) LED]	2 Keys
Fixed Feature Key	11 keys (with Menu/Cursor/Security button)(Note 1)			10 Keys(Note 1)	12 Keys
Backlight	Display and Digit Key (lit for 10 seconds when operating)			None	
Soft Key	4 Keys				None
Directory	500 records			None	
Call History	Outgoing Call: 50 record, Incoming Call: 50 records			None	
XML Browser	Available				None
Hands-free	Standard equipment (Full-duplex), Wide-band			Standard equipment (Full-duplex)	
Headset	Available			Not available	
LAN Interface	2-port, 10BASE-T/100BASE-TX, Full-duplex/Half-duplex, Auto Negotiation /Fixed				
Voice CODEC	G.711(μ-law, A-law), G.729a, G.722			G.711(μ-law, A-law), G.729a	
IP Address Setting	Sets via DHCP server/Sets Directly				
QoS	ToS (IP Precedence, Diffserv)				
VLAN	Tag VLAN (IEEE802.1Q/p)				
Security	IEEE802.1x authentication (EAP-MD5, EAPOL Forwarding), SIP&RTP Encryption				
Power Supply	Center Power Supply = IEEE802.3af, Local Power Supply = AC adapter (AC-2R UNIT: optional)				
Power Consumption	PoE=6.24 [W]/Local=5.64 [W]			PoE=3.264 [W]/Local=2.928 [W]	
Download	Program/Configuration data/Ringing Tone/Music on Hold/Directory data			Program/Configuration data/Music on Hold	
Adapter (Optional)	Recording Unit/Wall-mounting kit/Digit-key Set Unit/Key kit/Side panel			Wall-mounting kit/Digit-key Set Unit/Side panel	Wall-mounting kit /Side panel
Color	Black/White			Black	
Dimension (W×D×H)	179(W) × 264(D) × 112(H) [mm]	205.8(W) × 258(D) × 112(H) [mm]	179(W) × 258(D) × 112(H) [mm]	179(W) × 225(D) × 112(H) [mm]	
Weight	1.3 kg	1.3 kg	1.2 kg	1.1 kg	1.0 kg

Note 1: Optional Retro key kit supplies 12 Fixed Feature Keys

9. MENU LIST

MENU LIST FOR DT730 SERIES

Menu Item	Description
Menu	Press  key while indicating the current time on LCD.
1 History	To view call history data. Also, you can add the history data to the directory.
2 Directory	To access directory feature. There are the following three types of directory features: Personal Directory, Phonebook and Corporate Directory. This chapter explains the menu list for Personal Directory feature.
3 Tool	Uses when accessing external XML server. <u>For details, please contact the system administrator.</u>
4 Call Func.	Not used.
5 Setting	To access user settings.
6 Presence	Not used.
# Favorite	Not used.
0 Config	To make the configuration setting of DT Series. <u>For details, please contact the system administrator.</u>

Menu List For **1** History

Menu Item	Description	Default Value
1 History		
1 Missed	Displays the history of missed calls. You can also make a call from this menu.	-
2 Outgoing	Displays the history of outgoing calls. You can also make a call from this menu.	-
3 Incoming	Displays the history of incoming calls. You can also make a call from this menu.	-
4 Delete All	Deletes all the history data.	-

SubMenu (Press  key or **Option** soft key while the history data is displayed)

Menu Item	Description	Default Value
SubMenu		
1 Call	Make a call to the currently displayed party.	-
2 Directory Add	Add the currently displayed history data to the personal directory.	-
1 New	Add call history data to the personal directory.	-
Category Set	Select Company, Mobile, Voice Mail, Home or Others.	Company
Priority Flag	Select either Enable or Disable.	Disable
Edit	Edit the directory data.	-
2 Addition	Edit the personal directory data from call history.	-
Directory Search	Search the personal directory.	-
Directory	Register the telephone number to the searched directory data.	-
3 Prefix	Add Prefix to the telephone number and then make a call.	-
4 Delete One	Delete a specific data.	-
5 Delete All	Delete all history data of a specific call type (“missed”, “outgoing” or “incoming”)	-

Menu List For **2** Directory

Menu Item	Description	Default Value
2 Directory	From Menu screen, select 2 Directory → 1 Personal.	-
1 Search	Search the personal directory.	-
1 Group	Select a group as a search condition.	-
2 Name	Enter the target name and then perform a search.	-
3 Tel Number	Enter the target telephone number and then perform a search.	-
4 Other	Perform a search by one of the following conditions.	-
1 Memory ID	Enter a memory number.	-
2 Category	Select a category.	-
3 Company	Enter a company name.	-
4 Alphabet	Select a group of alphabets.	-
2 Edit	Add a new data to the personal directory.	-
1 Name	Enter a name of the target party to be added to the directory.	-
2 Group	Select a group to which the target party belongs.	Default
3-6 Tel #1-Tel #4	Enter the telephone number.	-
Category Set	Select Company, Mobile, Voice Mail, Home or Others.	Company
Priority Flag	Select either Enable or Disable.	Disable
7 Company Name	Enter the company name of the target party.	-
8 Ring Tone	Select a ringer tone type per caller.	Default (follows group settings) Note 1
9 Illumination	Select a illumination pattern (color) of the call indication lamp.	Default (follows group settings) Note 1
0 Memory ID	Enter a memory number to be assigned to the target party.	-

Menu Item		Description	Default Value
	3 Group Setting	Change a group name.	-
	Group Setting	Select a desired group name to be changed.	-
	1 Name	Enter a new group name.	-
	2 Ring Tone	Select a ringer tone type per group.	Default (follows terminal settings) Note 1
	3 Illumination	Select a illumination pattern (color) of the call indication lamp.	Default (follows terminal settings) Note 1
	4 Own Number	Displays the number of the telephone itself.	-
	0 Delete All	Delete all the registered directory data.	-

Note 1: For firmware versions earlier than 4.0.0.0, the default is "Automatic."

Menu List For **3** Tool

Menu Item		Description	Default Value
3 Tool			
	1 Service	Activate XML browser.	-
	2 IM	Not used.	-

Menu List For **5** Setting

Menu Item	Description	Default Value
5 Setting		
1 User Setting	Make the user setting of DT Series.	
1 Incoming Call	Settings for incoming call.	
1 Ring Volume	Not used.	-
2 Offhook Ring	Enable/Disable Off-hook ringing.	Enable
3 Headset Ring	Enable/Disable the ringing of headset.	Disable
4 Ring Tone	Select a ringer tone for External Call and Internal Call. Automatic / Tone Type 1~14 / Download 1~3	Automatic (Tone Type1)
5 Illumination	Set the illumination pattern for External Call and Internal Call. Automatic / Disable / Red / Green / Blue / Yellow / Purple Light Blue / White / Rotation	Automatic (Red)
6 Headset Ring Volume	Not used.	-
2 Talk	Settings for telephone conversation.	
1 RTP Alarm	Enable/disable RTP alarm.	Automatic
2 DTMF Tone	Enable/disable DTMF tone.	Automatic
3 Key Touch Tone	Set key touch tone generated when the digit keys are pressed while the telephone is off-hook.	Automatic
4 Hold Music	Select a Music on Hold to be heard by DT Series user.	Default
5 Prefix	Register Prefix number.	-
3 Display	Settings for LCD display.	-
1 Time Format	Determines whether time is displayed with a 12-hour or 24-hour clock format.	Automatic (12-hour format)
2 Local Volume	Determines whether or not to display the following volume levels: handset receiver volume, speaker volume, ringer tone volume and LCD contrast.	Automatic (Enable)
3 Screen Saver	Sets Screen Saver related data.	-

Menu Item		Description	Default Value
	1 Screen Saver Mode	Enable/Disable Screen Saver.	Disable
	2 Wait Time	Set the Wait Time to launch Screen Saver	120min
	4 Back Light	Enable/disable the backlights of LCD and digit keys.	Automatic (Enable)
	5 Font Size	Change the displayed character size on the LCD.	Standard(16dot)
	6 Language	Select a language to be displayed on LCD.	Automatic
	4 Change Password	Change the password to lock/unlock the telephone.	0000
	5 Security	Not used.	-
	6 Peripherals	Not used	-
	0 Setting Reset	Reset the telephone settings.	-
2	Download	Set the data required for the file downloading.	-
	1 Download Files	Download the files for Music on Hold, ringer tone and	-
	1 Hold Music	Download a file for Music on Hold.	MOH.wav
	2 Ring Tone	Download files for ringer tones	-
	1. Download 1	Download files for ringer tone (Download 1).	Melody1.wav
	2. Download 2	Download files for ringer tone (Download 2).	Melody2.wav
	3. Download 3	Download files for ringer tone (Download 3).	Melody3.wav
	3 Directory	Download the directory files.	Directory.csv
	2 Download Address	Enter an IP address of the FTP/TFTP server.	0.0.0.0
	3 Protocol	Select a protocol of the server (either FTP or TFTP).	FTP
	4 FTP Settings	Set necessary data when using FTP service.	-
	1 User ID	Enter a user ID for downloading via FTP server.	-
	2 Password	Enter a password for downloading via FTP server.	-
	3 Folder	Specify the directory where the download file is stored.	-
3	Data Backup/Restore	Set the data required for the file backup/restore.	-
	1 Data Backup	Specify the file name to be backed up.	PersonalData.tgz
	2 Data Restore	Specify the file name to be restored.	PersonalData.tgz

Menu Item		Description	Default Value
	3 Server Address	Enter an IP address of the FTP/TFTP server.	0.0.0.0
	4 Protocol	Select a protocol of the server (either FTP or TFTP).	FTP
	5 FTP Settings	Set necessary data when using FTP service.	-
	1 User ID	Enter a user ID for the data backup via FTP server.	-
	2 Password	Enter a password for data backup via FTP server.	-
	3 Folder	Specify the destination directory of FTP server.	-

MENU LIST FOR DT710 Series

Menu Item		Description
Menu		Press  key while indicating the current time on LCD.
1	Tool	Not used.
2	Setting	To make the user setting of DT Series.
0	Config	To make the configuration setting of DT Series. <u>For details, please contact the system administrator.</u>

Menu List For **1** Tool

Menu Item		Description	Default Value
1 Tool			
1	-----	Not used.	-

Menu List For **2** Setting

Menu Item	Description	Default Value
2 Setting		
1 User Setting	Make the user setting of DT Series.	
1 Incoming Call	Settings for incoming call.	
1 Offhook Ring	Enable/Disable Off-hook ringing.	Enable
2 Ring Tone	Select a ringer tone for External Call and Internal Call. Automatic / Tone Type 1~14	Automatic (Tone Type1)
3 Headset Ring Volume	Not used.	-
2 Talk	Settings for telephone conversation.	
1 RTP Alarm	Enable/disable RTP alarm.	Automatic
2 DTMF Tone	Enable/disable DTMF tone.	Automatic
3 Key Touch Tone	Set key touch tone generated when the digit keys are pressed while the telephone is off-hook.	Automatic
4 Hold Music	Select a Music on Hold to be heard by DT Series user.	Default
3 Display	Settings for LCD display.	-
1 Time Format	Determines whether time is displayed with a 12-hour or 24-hour clock format.	Automatic (12-hour format)
2 Local Volume	Determines whether or not to display the following volume levels: handset receiver volume, speaker volume, ringer tone volume and LCD contrast.	Automatic (Enable)
3 Screen Saver	Sets Screen Saver related data.	-
1 Screen Saver Mode	Enable/Disable Screen Saver.	Disable
2 Wait Time	Set the Wait Time to launch Screen Saver	120min
4 Language	Select a language to be displayed on LCD.	Automatic
4 Change Password	Change the password to lock/unlock the telephone.	0000
0 Setting Reset	Reset the telephone settings.	-
2 Download	Set the data required for the file downloading.	-

Menu Item		Description	Default Value
	1 Download Files	Download the files for Music on Hold, ringer tone and	-
	1 Hold Music	Download a file for Music on Hold.	MOH.wav
	2 Download Address	Enter an IP address of the FTP/TFTP server.	0.0.0.0
	3 Protocol	Select a protocol of the server (either FTP or TFTP).	FTP
	4 FTP Settings	Set necessary data when using FTP service.	-
	1 User ID	Enter a user ID for downloading via FTP server.	-
	2 Password	Enter a password for downloading via FTP server.	-
	3 Folder	Specify the directory where the download file is stored.	-
	3 Data Backup/Restore	Set the data required for the file backup/restore.	-
	1 Data Backup	Specify the file name to be backed up.	PersonalData.tgz
	2 Data Restore	Specify the file name to be restored.	PersonalData.tgz
	3 Server Address	Enter an IP address of the FTP/TFTP server.	0.0.0.0
	4 Protocol	Select a protocol of the server (either FTP or TFTP).	FTP
5 FTP Settings	Set necessary data when using FTP service.	-	
1 User ID	Enter a user ID for the data backup via FTP server.	-	
2 Password	Enter a password for data backup via FTP server.	-	
3 Folder	Specify the destination directory of FTP server.	-	

MENU LIST FOR DT330 Series

Menu Item		Description
Menu		Press  key while indicating the current time on LCD.
1	Call History	To view call history data.
2	Directory	To access Phonebook feature. For details, see PHONEBOOK in chapter 5.
3	Settings	To make the user setting of DT Series.

Menu List For **1** Call History

Menu Item		Description	Default Value
1 Call History			
	1 Incoming	Displays the history of incoming calls. You can also make a call from this menu.	-
	3 Outgoing	Displays the history of outgoing calls. You can also make a call from this menu.	-

This page is for your notes.

10. WEB PROGRAMMING

OUTLINE

Web Programming allows you to configure the terminal settings of DT Series from the PC. An Internet browser (Internet Explorer, etc.) is used to access Web Programming. It is not necessary to install any special application software onto the PC.

Note: This feature is only available for DT700 Series.

Note: DT700 Series and Web Programming PC needs to be connected to the same network. When downloading the files for Music on Hold, Ringer Tone and Directory to the DT Series, FTP (TFTP server) is required on the network. For details on the FTP service, contact the System Administrator.

Note: Terminal settings through the Web Programming is available while the DT700 Series logs into the system.

PC Requirements For Web Programming

Items	Operating Conditions
Operating System	Microsoft® Windows® XP/Vista
CPU	Comply with conditions for use of Microsoft® Windows or Microsoft® Internet Explorer.
Memory	
Browser	Microsoft® Internet Explorer 6.0 or later
Monitor	SVGA (minimum: 800 × 600 pixel, recommended: 1024 × 768 pixel,)
Others	Mouse, LAN connection port (RJ-45)

TO LOGIN

Follow the steps below to open the Web Programming.

STEP 1: Start up Internet browser on the PC.

STEP 2: Enter IP address of the target DT700 Series on the address toolbar and then press Enter key.

STEP 3: The Web Programming Login screen appears. Enter a user name (type "USER") and a password (**Note 1**), then click **OK**.

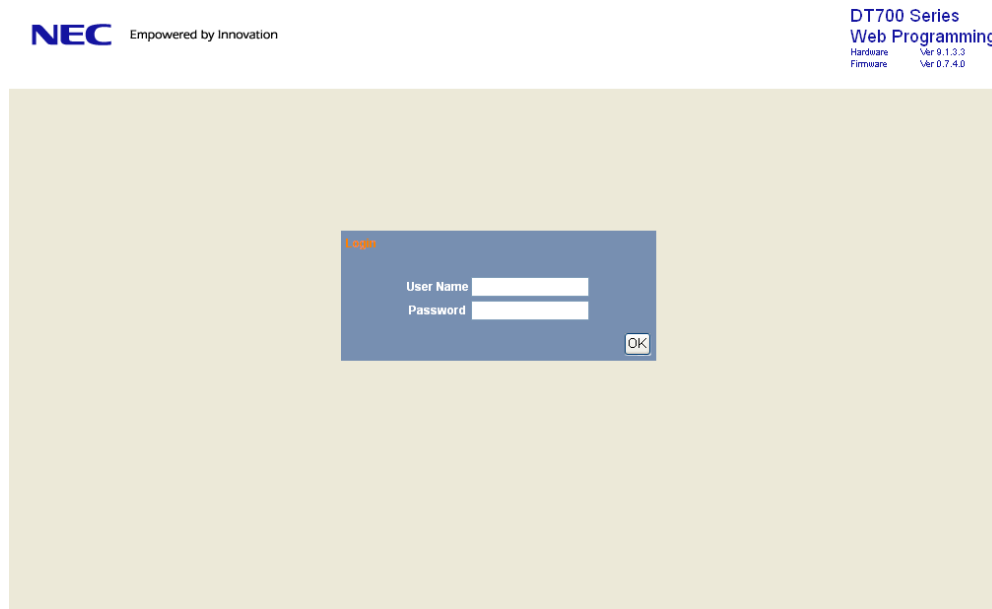

Note: Enter the same password used when logging into the DT750. "0000" is used as password by the default setting.

Note: For IP address of DT Series, contact the System Administrator.

Note: When the login screen does not appear, check the LAN connection status and entered IP address. If the problem persists, please contact the system administrator.

STEP 4: The following Web Programming **Home** screen appears.

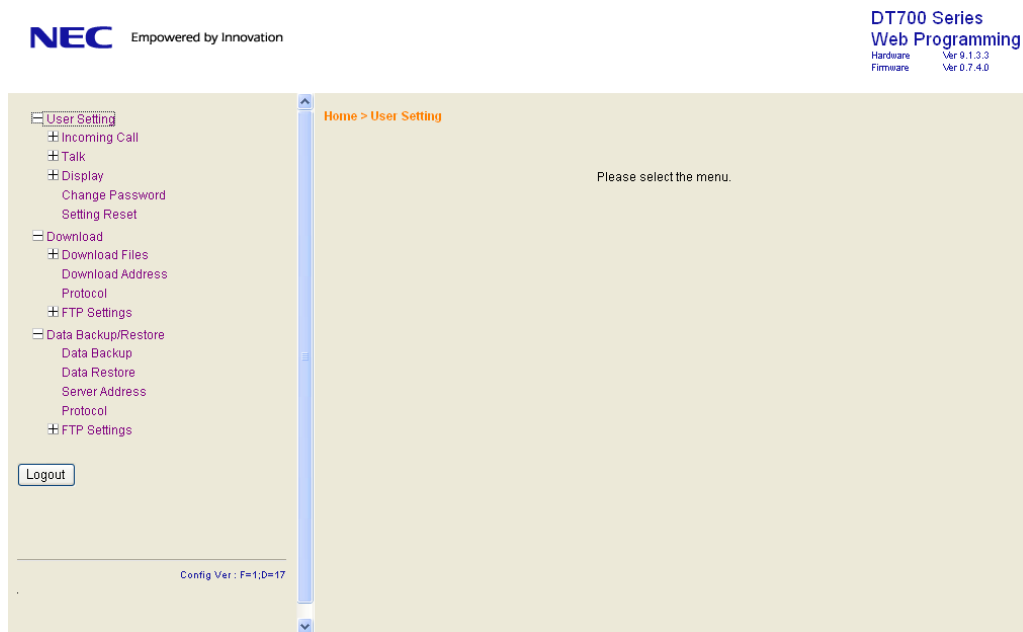

TO LOGOUT

Follow the steps below to exit the Web Programming.

STEP 1: Click **Logout** at the lower left of the screen.

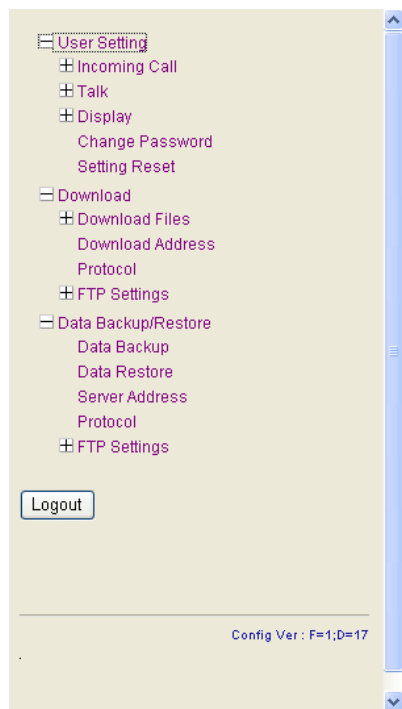

STEP 2: The confirmation message appears. Click **OK** to log out of Web Programming.

STEP 3: The display changes as follows. Click **Back**.



Logout complete.

Back

STEP 4: After the Web Programming Login screen is displayed, close the Internet browser.

Note: Make sure to perform the logout operation after the data setting of the telephone.

Note: When 15 minutes have passed leaving the PC without operation after log in to Web Programming, you are forcibly logged out from the Web Programming.

HOW TO OPERATE

As an example of setting method on the Web Programming, the following explains how to change the ringer tone for external call. Web Programming includes the same menu configuration as "Setting" of DT700 Series terminal. For details on each menu item, see [SETUP WITH MENU KEY FOR DT700 SERIES](#) in [3.TERMINAL SETUP](#).

STEP 1: From the **Home** screen, click **User Setting** → **Incoming Call** → **Ring Tone** → **External Call**.

STEP 2: Select a desired tone type by clicking the corresponding radio button.

STEP 3: Click **OK** to save the change to the database.

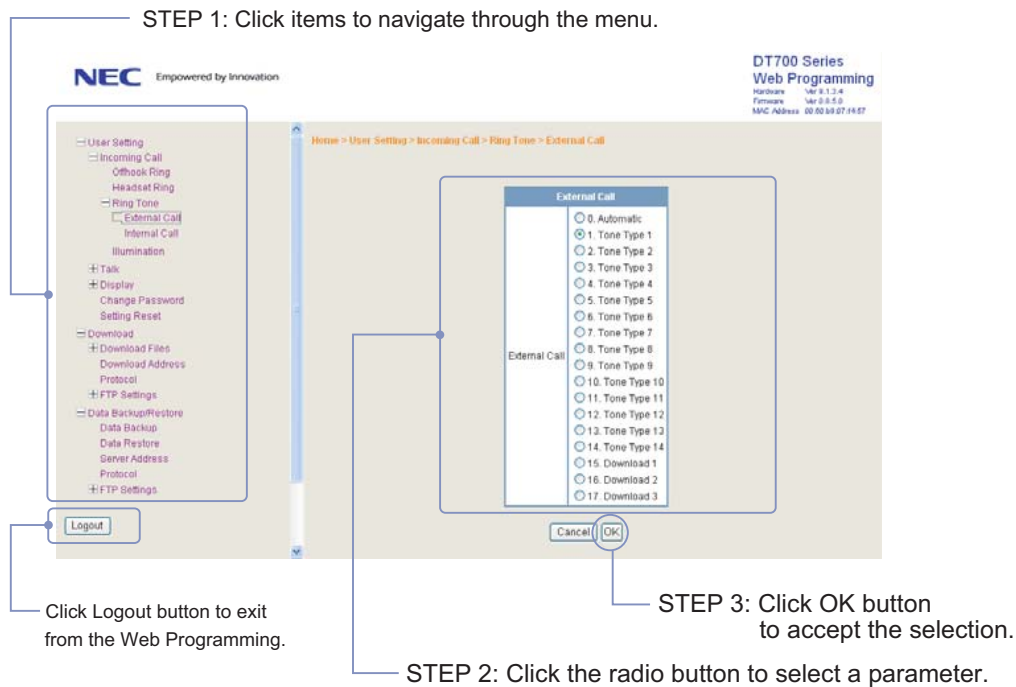

STEP 4: A confirmation dialog appears. Click **OK** on the dialog.

Printed in Japan
1008-040

