

NEC

MultiSync LCD3090WQXi

User's Manual



Index

Warning, Caution	English-1
Declaration	English-1
Canadian Department of Communications Compliance Statement	English-2
Declaration of Conformity	English-2
Recommended use	English-3
Contents	English-5
Quick Start	English-6
Controls	English-10
Specifications	English-15
Features	English-16
Troubleshooting	English-17
Appendix	English-18
Self Calibration	English-25
White Point Matching/Copy Calibration	English-27
Using the Auto Brightness function	English-29
TCO'03	English-30
TCO'06	English-31
Manufacturer's Recycling and Energy Information	English-32

**WARNING**

TO PREVENT FIRE OR SHOCK HAZARDS, DO NOT EXPOSE THIS UNIT TO RAIN OR MOISTURE. ALSO, DO NOT USE THIS UNIT'S POLARIZED PLUG WITH AN EXTENSION CORD RECEPTACLE OR OTHER OUTLETS UNLESS THE PRONGS CAN BE FULLY INSERTED.

REFRAIN FROM OPENING THE CABINET AS THERE ARE HIGH VOLTAGE COMPONENTS INSIDE. REFER SERVICING TO QUALIFIED SERVICE PERSONNEL.

**CAUTION**

CAUTION: TO REDUCE THE RISK OF ELECTRIC SHOCK, MAKE SURE POWER CORD IS UNPLUGGED FROM WALL SOCKET. TO FULLY DISENGAGE THE POWER TO THE UNIT, PLEASE DISCONNECT THE POWER CORD FROM THE AC OUTLET. DO NOT REMOVE COVER (OR BACK). NO USER SERVICEABLE PARTS INSIDE. REFER SERVICING TO QUALIFIED SERVICE PERSONNEL.



This symbol warns user that uninsulated voltage within the unit may have sufficient magnitude to cause electric shock. Therefore, it is dangerous to make any kind of contact with any part inside this unit.



This symbol alerts the user that important literature concerning the operation and maintenance of this unit has been included. Therefore, it should be read carefully in order to avoid any problems.

CAUTION: Please use the power cord provided with this display in accordance with the table below. If a power cord is not supplied with this equipment, please contact your supplier. For all other cases, please use a power cord that matches the AC voltage of the power outlet and has been approved by and complies with the safety standard of your particular country.

Plug Type	North America	European Continental	U.K.	Chinese	Japanese
Plug Shape					
Country	U.S.A./Canada	EU (except U.K.)	U.K.	China	Japan
Voltage	120*	230	230	220	100

*When operating the MultiSync LCD3090WQXi monitor with its AC 125-240V power supply, use a power supply cord that matches the power supply voltage of the AC power outlet being used.

NOTE: This product can only be serviced in the country where it was purchased.

Declaration

Declaration of the Manufacturer

We hereby certify that the color monitors MultiSync LCD3090WQXi (L307TD) is in compliance with

Council Directive 2006/95/EC:

– EN 60950-1

Council Directive 2004/108/EC:

– EN 55022

– EN 61000-3-2

– EN 61000-3-3

– EN 55024

and marked with



NEC Display Solutions, Ltd.
4-13-23, Shibaura,
Minato-Ku
Tokyo 108-0023, Japan



Windows is a registered trademark of Microsoft Corporation. NEC is a registered trademark of NEC Corporation.

ENERGY STAR is a U.S. registered trademark.

ErgoDesign is a registered trademark of NEC Display Solutions, Ltd. in Austria, Benelux, Denmark, France, Germany, Italy, Norway, Spain, Sweden, U.K.

All other brands and product names are trademarks or registered trademarks of their respective owners.

As an ENERGY STAR® Partner, NEC Display Solutions of America, Inc. has determined that this product meets the ENERGY STAR guidelines for energy efficiency. The ENERGY STAR emblem does not represent EPA endorsement of any product or service.

Canadian Department of Communications Compliance Statement

DOC: This Class B digital apparatus meets all requirements of the Canadian Interference-Causing Equipment Regulations.

C-UL: Bears the C-UL Mark and is in compliance with Canadian Safety Regulations according to CAN/CSA C22.2 No. 60950-1.

FCC Information

1. Use the attached specified cables with the MultiSync LCD3090WQXi color monitor so as not to interfere with radio and television reception.
 - (1) The power supply cord you use must have been approved by and comply with the safety standards of U.S.A., and meet the following condition.

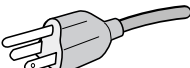
Power supply cord	Non shield type, 3-conductor
Length	2.0 m
Plug shape	
	U.S.A

- (2) Please use the supplied shielded video signal cable, 15-pin mini D-SUB to DVI-A cable or DVI-D to DVI-D cable. Use of other cables and adapters may cause interference with radio and television reception.
2. This equipment has been tested and found to comply with the limits for a Class B digital device, pursuant to part 15 of the FCC Rules. These limits are designed to provide reasonable protection against harmful interference in a residential installation. This equipment generates, uses, and can radiate radio frequency energy, and, if not installed and used in accordance with the instructions, may cause harmful interference to radio communications. However, there is no guarantee that interference will not occur in a particular installation. If this equipment does cause harmful interference to radio or television reception, which can be determined by turning the equipment off and on, the user is encouraged to try to correct the interference by one or more of the following measures:
 - Reorient or relocate the receiving antenna.
 - Increase the separation between the equipment and receiver.
 - Connect the equipment into an outlet on a circuit different from that to which the receiver is connected.
 - Consult your dealer or an experienced radio/TV technician for help.

If necessary, the user should contact the dealer or an experienced radio/television technician for additional suggestions. The user may find the following booklet, prepared by the Federal Communications Commission, helpful: "How to Identify and Resolve Radio-TV Interference Problems." This booklet is available from the U.S. Government Printing Office, Washington, D.C., 20402, Stock No. 004-000-00345-4.

Declaration of Conformity

This device complies with Part 15 of FCC Rules. Operation is subject to the following two conditions. (1) This device may not cause harmful interference, and (2) this device must accept any interference received, including interference that may cause undesired operation.

U.S. Responsible Party:	NEC Display Solutions of America, Inc.
Address:	500 Park Blvd, Suite 1100 Itasca, Illinois 60143
Tel. No.:	(630) 467-3000

Type of Product:	Display Monitor
Equipment Classification:	Class B Peripheral
Models:	MultiSync LCD3090WQXi (L307TD)



We hereby declare that the equipment specified above conforms to the technical standards as specified in the FCC Rules.

Recommended use

Safety Precautions and Maintenance



FOR OPTIMUM PERFORMANCE, PLEASE NOTE
THE FOLLOWING WHEN SETTING UP AND
USING THE LCD COLOR MONITOR:



- **DO NOT OPEN THE MONITOR.** There are no user serviceable parts inside and opening or removing covers may expose you to dangerous shock hazards or other risks. Refer all servicing to qualified service personnel.
- Do not spill any liquids into the cabinet or use your monitor near water.
- Do not insert objects of any kind into the cabinet slots, as they may touch dangerous voltage points, which can be harmful or fatal or may cause electric shock, fire or equipment failure.
- Do not place any heavy objects on the power cord. Damage to the cord may cause shock or fire.
- Do not place this product on a sloping or unstable cart, stand or table, as the monitor may fall, causing serious damage to the monitor.
- The power supply cord you use must have been approved by and comply with the safety standards of your country. (Type H05VV-F 3G 1mm² should be used in Europe).
- In UK, use a BS-approved power cord with molded plug having a black (13A) fuse installed for use with this monitor.
- Do not place any objects onto the monitor and do not use the monitor outdoors.
- The lamps in this product contain mercury. Please dispose according to state, local or federal law.
- Do not bend power cord.
- Do not use monitor in very hot, humid, dusty, or oily areas.
- Do not cover vent on monitor.
- Vibration can damage the backlight. Do not install where the monitor will be exposed to continual vibration.
- If monitor or glass is broken, do not come in contact with the liquid crystal and handle with care.
- To prevent damage to the LCD monitor caused by tipping over due to earthquakes or other shocks, make sure to install the monitor in a stable location and take measures to prevent falling.

Immediately unplug your monitor from the wall outlet and refer servicing to qualified service personnel under the following conditions:

- When the power supply cord or plug is damaged.
- If liquid has been spilled, or objects have fallen into the monitor.
- If the monitor has been exposed to rain or water.
- If the monitor has been dropped or the cabinet damaged.
- If the monitor does not operate normally by following operating instructions.



CAUTION

- Allow adequate ventilation around the monitor so that heat can properly dissipate. Do not block ventilated openings or place the monitor near a radiator or other heat sources. Do not put anything on top of monitor.
- The power cable connector is the primary means of detaching the system from the power supply. The monitor should be installed close to a power outlet which is easily accessible.
- Handle with care when transporting. Save packaging for transporting.
- The monitor must be installed or carried by two or more people.
- Carry the monitor holding the built-in handle and bottom frames of the monitor.
- Do not carry holding only the stand.

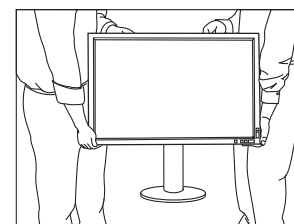

Image Persistence: Image persistence is when a residual or “ghost” image of a previous image remains visible on the screen. Unlike CRT monitors, LCD monitors’ image persistence is not permanent, but constant images being displayed for a long period of time should be avoided.

To alleviate image persistence, turn off the monitor for as long as the previous image was displayed. For example, if an image was on the monitor for one hour and a residual image remains, the monitor should be turned off for one hour to erase the image.

NOTE: As with all personal display devices, NEC DISPLAY SOLUTIONS recommends using a moving screen saver at regular intervals whenever the screen is idle or turning off the monitor when not in use.



CORRECT PLACEMENT AND ADJUSTMENT OF THE MONITOR CAN REDUCE EYE, SHOULDER AND NECK FATIGUE. CHECK THE FOLLOWING WHEN YOU POSITION THE MONITOR:



- For optimum performance, allow 20 minutes for warm-up.
- Adjust the monitor height so that the top of the screen is at or slightly below eye level. Your eyes should look slightly downward when viewing the middle of the screen.
- Position your monitor no closer than 40 cm and no further away than 70 cm from your eyes. The optimal distance is 50 cm.
- Rest your eyes periodically by focusing on an object at least 20 feet away. Blink often.
- Position the monitor at a 90° angle to windows and other light sources to minimize glare and reflections. Adjust the monitor tilt so that ceiling lights do not reflect on your screen.
- If reflected light makes it hard for you to see your screen, use an anti-glare filter.
- Clean the LCD monitor surface with a lint-free, non-abrasive cloth. Avoid using any cleaning solution or glass cleaner!
- Adjust the monitor's brightness and contrast controls to enhance readability.
- Use a document holder placed close to the screen.
- Position whatever you are looking at most of the time (the screen or reference material) directly in front of you to minimize turning your head while you are typing.
- Avoid displaying fixed patterns on the monitor for long periods of time to avoid image persistence (after-image effects).
- Get regular eye checkups.

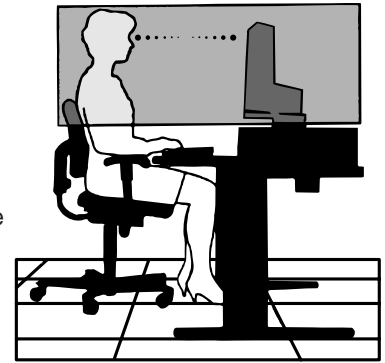

Ergonomics

To realize the maximum ergonomics benefits, we recommend the following:

- Adjust the Brightness until the background raster disappears.
- Do not position the Contrast control to its maximum setting.
- Use the preset Size and Position controls with standard signals.
- Use the preset Color Setting.
- Use non-interlaced signals with a vertical refresh rate of more than 60 Hz.
- Do not use primary color blue on a dark background, as it is difficult to see and may produce eye fatigue due to insufficient contrast.

Cleaning the LCD Panel

- When the liquid crystal panel is stained with dust or dirt, please wipe gently with soft cloth.
- Please do not rub the LCD panel with hard or coarse material.
- Please do not apply pressure to the LCD surface.
- Please do not use OA cleaner as it will cause deterioration or discolor on the LCD surface.

Cleaning the Cabinet

- Unplug the power supply
- Gently wipe the cabinet with a soft cloth
- To clean the cabinet, dampen the cloth with a neutral detergent and water, wipe the cabinet and follow with a dry cloth.

NOTE: Many plastics are used on the surface of the cabinet. DO NOT clean with benzene, thinner, alkaline detergent, alcoholic system detergent, glass cleaner, wax, polish cleaner, soap powder, or insecticide. Do not touch rubber or vinyl to the cabinet for a long time. These types of fluids and fabrics can cause the paint to deteriorate, crack or peel.

Contents

Your new NEC monitor box* should contain the following:

- MultiSync LCD3090WQXi monitor with tilt/swivel/pivot/height adjust stand
- Power Cord
- Video Signal Cable (15-pin mini D-SUB male to DVI-A)
- Video Signal Cable (DVI-D to DVI-D cable)
- User's Manual
- CD-ROM
- Cable Cover
- Screw (x 4) (to mount the monitor to a flexible arm (page 9))
- Clamp

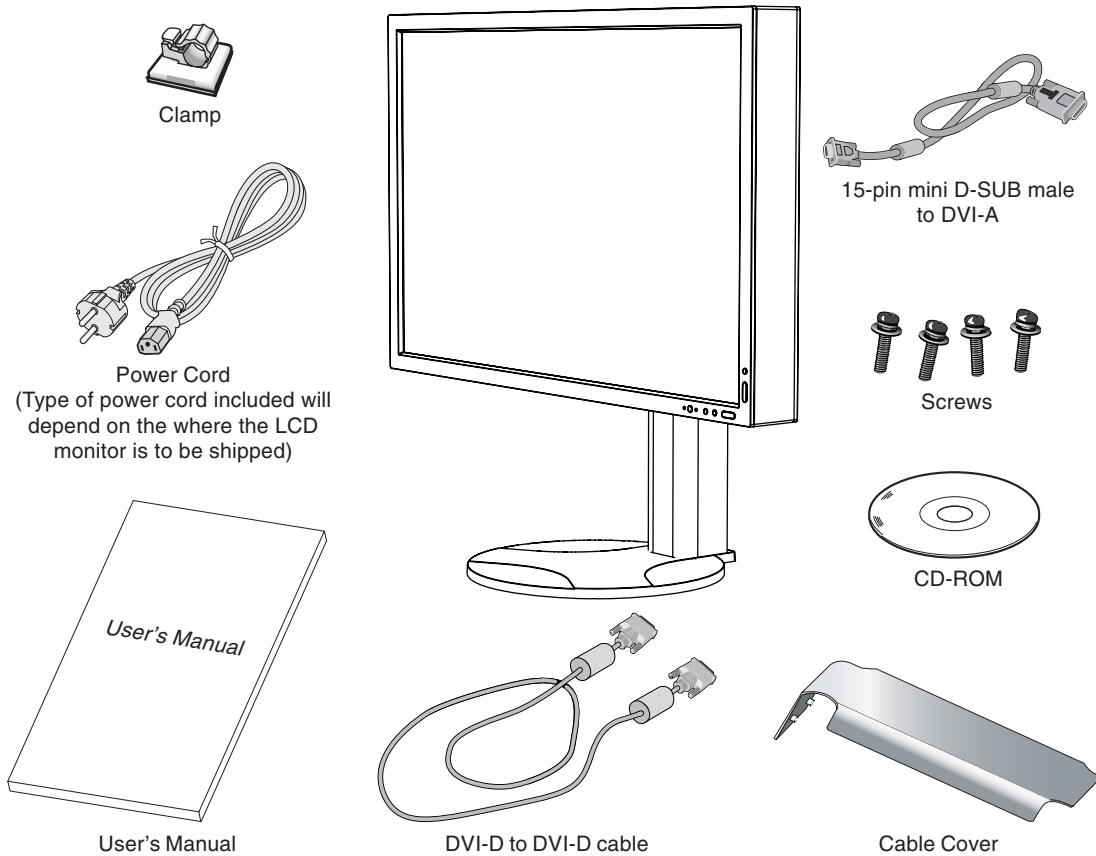

NOTE: This monitor can be equipped with optional loudspeakers: "MultiSync Sound bar". Please ask your dealer or check our website <http://www.necdisplaysolutions.com>

When using the optional Sound bar, please attach the cable to the monitor as shown, using the enclosed clamp.

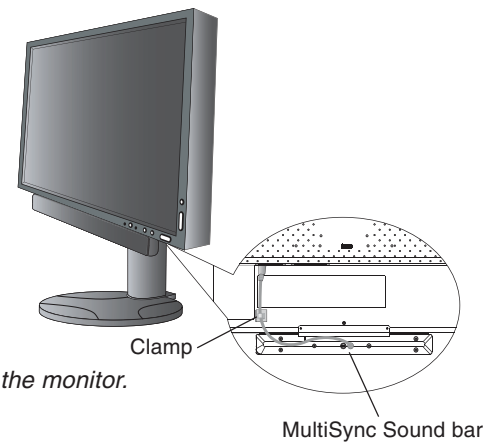

* Remember to save your original box and packing material to transport or ship the monitor.

Quick Start

To attach the LCD monitor to your system, follow these instructions:

NOTE: Make sure to read “Recommended Use” before installation.
 In order to display the maximum resolution, a video card that can output a resolution of 2560 x 1600 is needed.
 The monitor must be installed or carried by two or more people.

1. Turn off the power to your computer.
2. **For the PC or MAC with DVI digital output:** Connect the DVI signal cable to the connector of the display card in your system (**Figure A.1**). Tighten all screws.

For the PC with Analog output: Connect the 15-pin mini D-SUB to DVI-A signal cable to the connector of the display card in your system (**Figure A.2**).

For the MAC: Connect the Macintosh cable adapter to the computer, then attach the 15-pin mini D-SUB signal cable to the Macintosh cable adapter (**Figure B.1**).

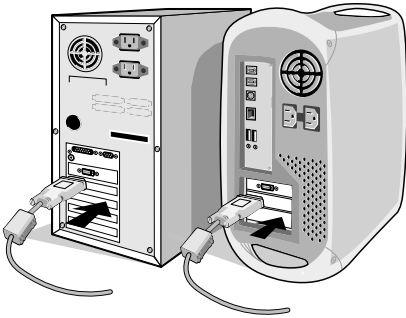
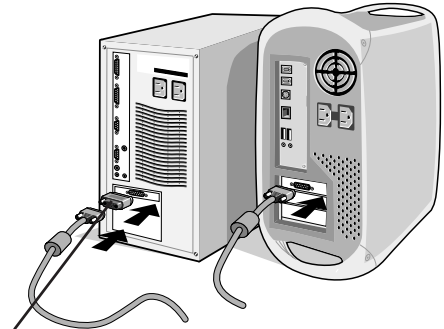

Figure A.1



Figure A.2



Macintosh
Cable Adapter
(not included)

Figure B.1

NOTE: Some Macintosh systems do not require a Macintosh cable adapter.

3. Place hands on each side of the monitor to tilt the LCD panel to a 30° angle and lift up to the highest position (**Figure C.1**).
4. Connect all cables to the appropriate connectors (**Figure C.1**).

NOTE: Incorrect cable connections may result in irregular operation, damage display quality/components of LCD module and/or shorten the module’s life.

5. To keep the cables neatly organized, place them into the cable management system that is built into the stand.
 Place the power cable into the specific hooks as indicated (**Figure C.2**).

Place the DVI cable and the 15-pin mini D-Sub to DVI-A cable into the hooks as indicated (**Figure C.3**).

When using the monitor in Portrait mode, place the DVI cable and the 15-pin mini D-Sub to DVI-A cable into the hooks as indicated (**Figure C.4**).

6. Make sure all cables are resting flat against the stand (**Figure C.3**).

Please check Tilt, Rise and Lower monitor screen and screen rotation when you manage cables.

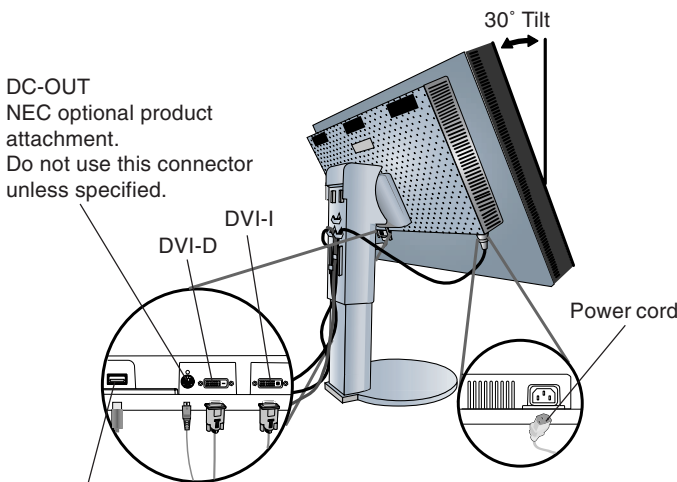

Figure C.1

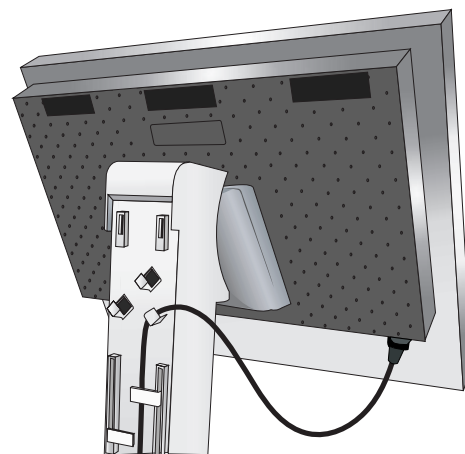

Figure C.2

SENSOR PORT
 For optional external sensor used for self calibration and copy calibration (Page 25).

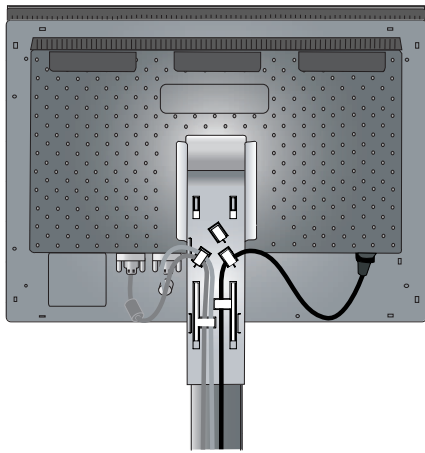

Figure C.3

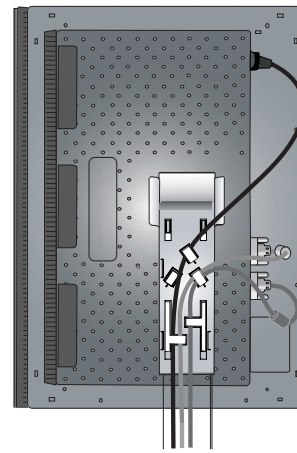

Figure C.4

7. Hold all cables firmly and place the cable cover onto the stand (**Figure D.1**). To remove the cable cover, lift the cover off as shown in **Figure D.2**.
8. Connect one end of the power cord to the AC inlet on the back of the monitor and the other end to the power outlet.

NOTE: Please refer to Caution section of this manual for proper selection of AC power cord.

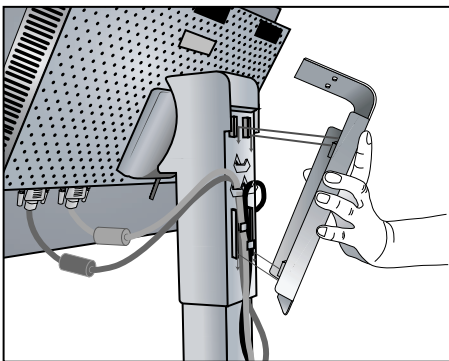

Figure D.1

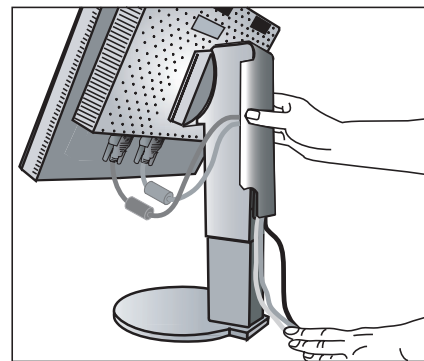

Figure D.2

9. The Vacation Switch on the left side of the monitor must be turned on. Turn on the monitor with the front power button (**Figure E.1**) and the computer.

NOTE: The Vacation Switch is a true on/off switch. If this switch is on the OFF position, the monitor cannot be turned on using the front button. DO NOT switch on/off repeatedly.

10. No-touch auto adjust automatically adjusts the monitor to optimal settings upon initial setup for most timings. For further adjustments, use the following OSD controls:

- Auto Contrast (Analog input only)
- Auto Adjust (Analog input only)

Refer to the **Controls** section of this User's Manual for a full description of these OSD controls.

NOTE: If you have any problems, please refer to the **Troubleshooting** section of this User's Manual.

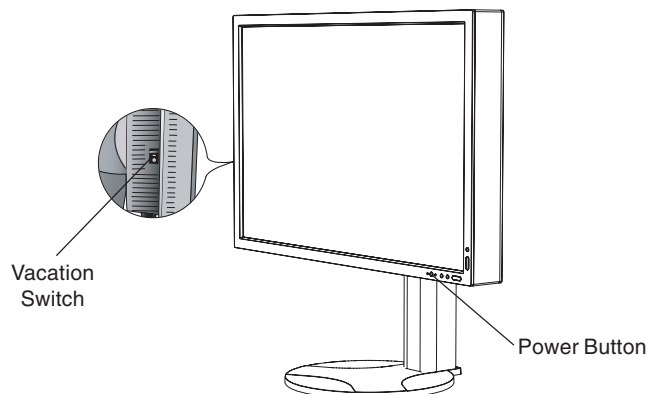

Figure E.1

Raise and Lower Monitor Screen

The monitor may be raised or lowered in either Portrait or Landscape mode. To raise or lower screen, place hands on each side of the monitor and lift or lower to the desired height (**Figure RL.1**).

NOTE: Handle with care when raising or lowering the monitor screen.

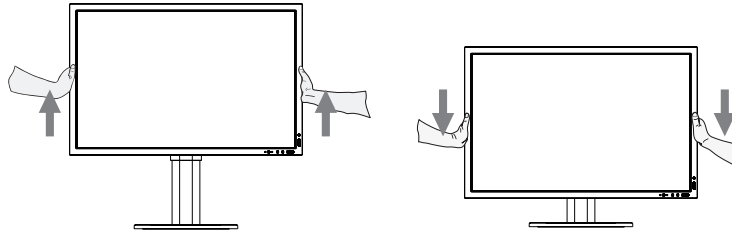

Figure RL.1

Screen Rotation

Before rotating, the screen must be raised to the highest level to avoid knocking the screen on the desk or pinching with your fingers.

To raise the screen, place hands on each side of the monitor and lift up to the highest position (**Figure RL.1**).

To rotate screen, place hands on each side of the monitor screen and turn clockwise from Landscape to Portrait or counter-clockwise from Portrait to Landscape (**Figure R.1**).

To rotate OSD menu between landscape and portrait, refer to “**Controls**” section.

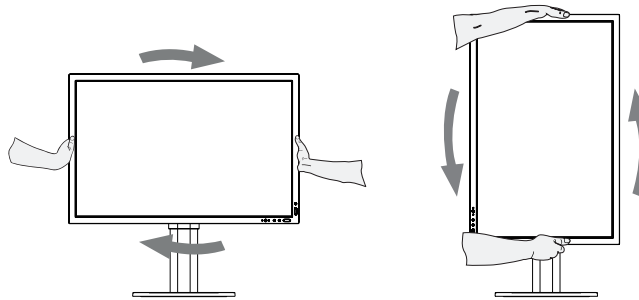

Figure R.1

Tilt

Grasp top and bottom sides of the monitor screen with your hands and adjust the tilt as desired (**Figure TS.1**).

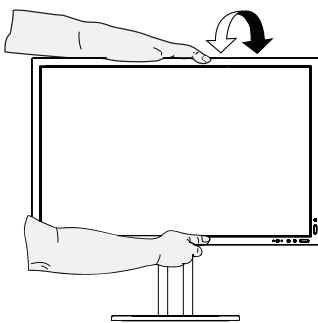

Figure TS.1

Swivel

Grasp both sides of the monitor screen with your hands and adjust the swivel as desired (**Figure TS.2**).

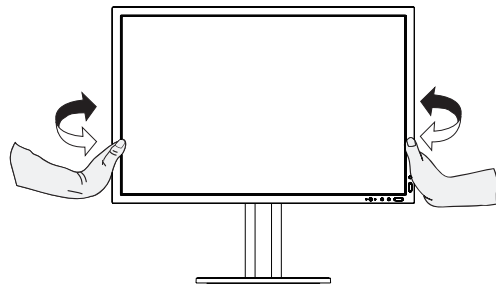

Figure TS.2

NOTE: Handle with care when tilting the monitor screen.

Flexible Arm Installation

This LCD monitor is designed for use with a flexible arm.

To prepare the monitor for alternate mounting purposes:

NOTE: The monitor must be installed or moved by two or more people.

- Refer to instructions included with the flexible arm for detailed instructions.
- To fulfill the safety requirements the monitor must be mounted to an arm, which guarantees the necessary stability under consideration of the weight of the monitor.

Remove Monitor Stand

1. Remove the cable cover.
2. Disconnect all cables.
3. Place hands on each side of the monitor and lift up to the highest position.
4. Place monitor face down on a non-abrasive surface (**Figure S.1**).

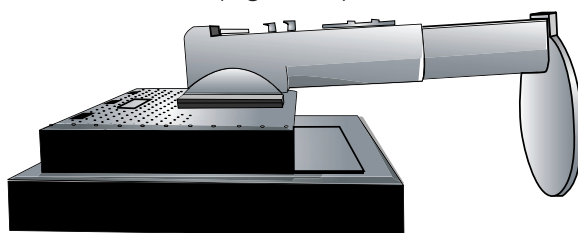

Figure S.1

5. Place one hand around the base and one hand on the Quick Release Lever. Move the Quick Release Lever in the direction indicated by the arrows (**Figure S.2**).
6. Lift up the bottom of the stand to unhook it from the monitor (**Figure S.3**). The monitor can now be mounted using an alternate method. Reverse process to reattach stand.

NOTE: Handle with care when removing monitor stand and avoid pinching your fingers.

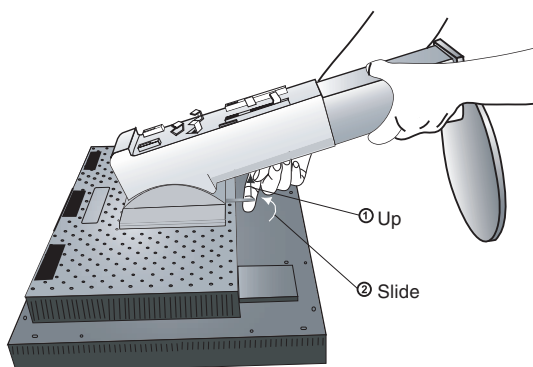

Figure S.2

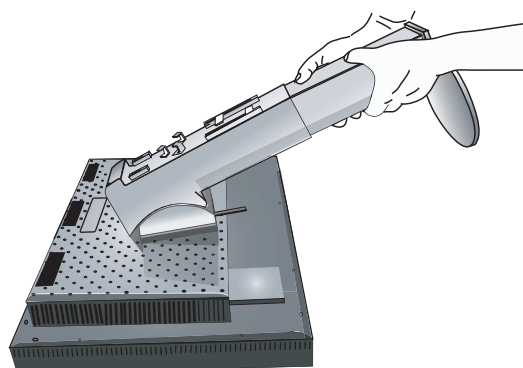
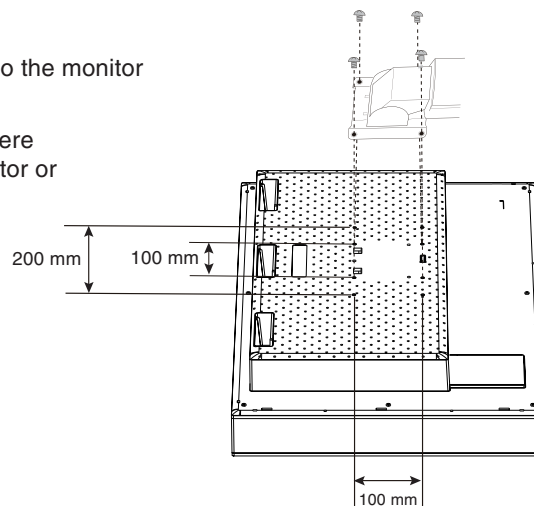

Figure S.3

Mount Flexible arm

1. Using the 4 screws from the stand removal and attach the arm to the monitor (**Figure F.1**).

- Caution:**
- When mounting, use ONLY the screws (4 pcs) that were removed from the stand to avoid damage to the monitor or stand.
 - The monitor should only be used with an approved arm (e.g. GS mark).
 - When using mounting accessories (e.g. VESA (200 x 100)) other than VESA (100 x 100), use M4 size screws (Length: bracket thickness + 10mm). Recommended Fasten Force: 98 - 137N•cm
 - To avoid blocking vent, keep adequate space above and behind the monitor when using with flexible arm.



Weight of LCD assembly: 14.4 kg

Figure F.1

Controls

OSD (On-Screen Display) control buttons on the front of the monitor function as follows:

To access OSD menu, press the MENU button.
 To change signal input, press the SELECT button.

NOTE: OSD must be closed in order to change signal input.

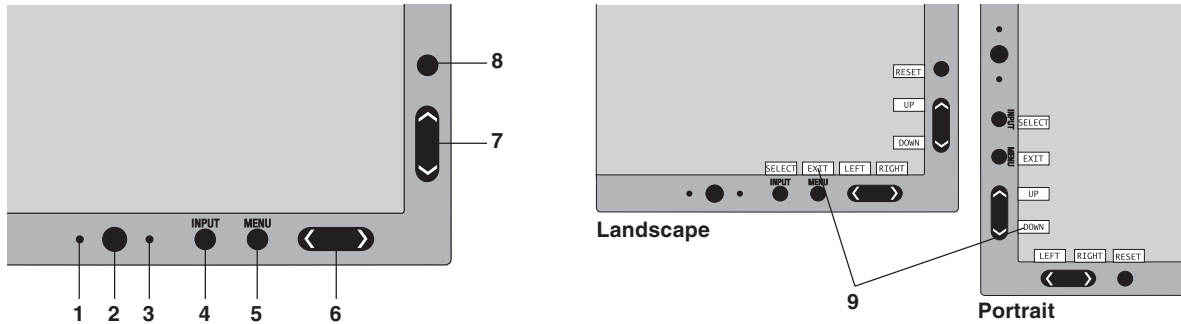

1 AUTO DIMMING SENSOR	Detects the level of ambient light, allowing the monitor to make adjustments to various settings, resulting in a more comfortable viewing experience. Do not cover this sensor.
2 POWER	Turns the monitor on and off.
3 LED	Indicates that the power is on. Can be changed between blue and green in the Advanced OSD Control menu.
4 INPUT/SELECT	Enters the OSD Control menu. Enters OSD sub menus. Changes the input source when not in the OSD Control menu.
5 MENU/EXIT	Access OSD menu. Exits the OSD sub menu. Exits OSD Control menu.
6 LEFT/RIGHT	Navigates to the left or right through the OSD Control menu. You can adjust the brightness directly, while the OSD menu is off. The HotKey function is enabled by default.
7 UP/DOWN	Navigates up or down through the OSD Control menu. You can adjust the contrast directly, while the OSD menu is off. The HotKey function is enabled by default.
8 RESET/ROTATE OSD	Resets the OSD back to factory settings. When pressed when the OSD is not showing, rotates the OSD Control menu between portrait and landscape mode (Page 23, Tag9 "OSD ROTATION").*
9 KEY GUIDE	The Key Guide appears on screen when the OSD control menu is accessed. The Key Guide will rotate when the OSD control menu is rotated.

* The "LEFT/RIGHT" and "UP/DOWN" buttons functionality is interchangeable depending on the orientation (landscape/portrait) of the OSD.

SETTING OSD LANGUAGE

- Set the OSD language before using OSD functions.
- To access the "LANGUAGE SELECTION" menu, press control key (LEFT/RIGHT or UP/DOWN or EXIT).
- Press the LEFT/RIGHT or UP/DOWN buttons to select the desired OSD language.
- To exit from this OSD menu, press EXIT button.

NOTE: Setting the OSD language is only necessary upon initial setup. The OSD language will stay the same until changed by the user.



Brightness/Contrast Controls

BRIGHTNESS

Adjusts the overall image and background screen brightness.

NOTE: The upper portion (higher settings) of the brightness level is adjusted using the backlight output. If a very low brightness level (low setting) is used the contrast level may be reduced. The display will digitally compensate for low brightness level. If this occurs, the indicator on the OSD will turn magenta.

CONTRAST

Adjusts the image brightness in relation to the background.

AUTO CONTRAST (Analog input only)

Adjusts the image displayed for non-standard video inputs.

ECO MODE

Decreases the amount of power consumed by reducing the brightness level.

1: Decreases the brightness by 25%.

2: Decreases the brightness by 50%.

CUSTOM: Decreases the brightness level as determined by the user. Refer to the Advanced OSD menu for custom setting instructions.

AUTO BRIGHTNESS

There are three settings for Auto Brightness.

OFF: No function.

1: Adjusts the brightness automatically, by detecting the brightness level of your environment and adjusting the monitor with the best BRIGHTNESS setting*1.

2: Adjusts the brightness automatically for the best BRIGHTNESS setting based on the white display area. The environmental brightness sensor (AUTO DIMMING SENSOR) has no function.

NOTE: Do not cover environmental brightness sensor (AUTO DIMMING SENSOR). When "AUTO LUMINANCE" (Page 18, Tag1) is ON, this function is disabled.

*1: Please refer to Page 29 for full "Auto Brightness" information.

BLACK LEVEL

Adjust the black level.



Auto Adjust (Analog input only)

Automatically adjusts the Image Position and H. Size settings and Fine settings.



Image Controls

LEFT / RIGHT

Controls Horizontal Image Position within the display area of the LCD.

DOWN / UP

Controls Vertical Image Position within the display area of the LCD.

H.SIZE (V.SIZE) (Analog input only)

Adjust the horizontal size by increasing or decreasing this setting.

If the "AUTO Adjust function" do not give you a satisfactory picture setting, a further tuning can be performed using the "H.Size (or V.Size)" function (dot clock). For this a Moiré test pattern could be used. This function may alter the width of the picture. Use Left/Right Menu to center the image on the screen. If the H.Size (or V.Size) is wrongly calibrated, the result would look like the left drawing. The image should be homogeneous.

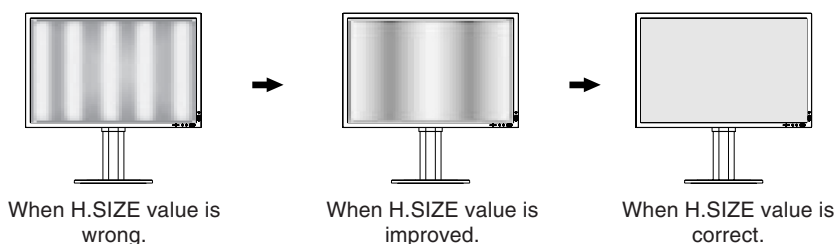

FINE (Analog input only)

Improve focus, clarity and image stability by increasing or decreasing this setting.

If the "Auto Adjust function" and the "H.Size" function do not give you a satisfactory picture setting, a fine tuning can be performed using the "Fine" function.

For this a Moiré test pattern could be used. If the Fine value is wrongly calibrated, the result would look like the left drawing. The image should be homogeneous.

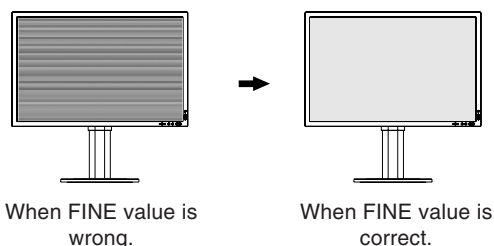

AUTO FINE (Analog input only)

This function automatically and periodically adjusts the "FINE" setting for change in signal condition.

This function adjusts approximately every 33 minutes.

EXPANSION

Sets the zoom method.

FULL: The image is expanded to 2560 x 1600, regardless of the resolution.

ASPECT: The image is expanded without changing the aspect ratio.

OFF: The image is not expanded.

CUSTOM: Refer to the ADVANCED OSD Controls menu section of the user's manual for detailed instructions.



Color Control Systems

Color Control Systems: Seven preset color settings.

For preset settings 1, 2, 3 and 5, the following levels can be adjusted:

TEMPERATURE: Adjust the white temperature by increasing or decreasing this setting. A lower color temperature will make the screen reddish and a higher color temperature will make the screen bluish.

WHITE (White Balance): If TEMPERATURE needs further adjustment, the individual R/ G/ B/ levels of the white point can be adjusted. To adjust the R/G/B levels, CUSTOM must be showing as the TEMPERATURE selection.

HUE: Adjusts the hue of each color*¹. The change in color will appear on screen and the menu color bars will show the amount of adjustment.

SATURATION: Adjusts the color depth of each color*¹. Press the "RIGHT" button and the color vividness increases.

OFFSET: Adjusts the color brightness of each color*¹. Press "RIGHT" button and the color Brightness increases.

*¹: RED, YELLOW, GREEN, CYAN, BLUE and MAGENTA.

NATIVE, sRGB: Original color presented by the LCD panel that is unadjustable.

PROGRAMMABLE: The color tone that was set up with the special application software is reflected.

NOTE: To reset a poor image setting, turn on the monitor by using front power button while holding "RESET" and "SELECT" buttons at the same time.



Tools

SHARPNESS

This function is digitally capable of keeping independently for crisp image at any time. It is continuously adjustable to get as distinct or as soft an image as you prefer and is set independently for different timings.

DVI SELECTION

This function selects the DVI input mode (DVI-I). When the DVI selection has been changed, the computer has to be restarted.

AUTO: When using the DVI-D to DVI-D cable, the DVI SELECTION is DIGITAL.

When using the D-SUB to DVI-A cable, the DVI SELECTION is ANALOG.

DIGITAL: DVI digital input is available.

ANALOG: DVI analog input is available.

NOTE: For the MAC with digital output: Before turning on the MAC, the DVI Input mode must be set to DIGITAL in "DVI SELECTION" menu of OSD by pressing "SELECT" button then "CONTROL" button when the DVI signal cable is connected to the DVI-I connector (DVI-I) of the monitor. Otherwise the MAC may not turn on.

NOTE: Depending on the PC and Video card used, or when another Video signal cable is attached, this function may not operate.

HDCP CONTENT (Digital Input Only)

Selects the type of input to be used with HDCP CONTENT.

OFF: When a PC or other computer equipment is connected, select "OFF".

ON: When a DVD player or other type of high definition device is connected, select "ON".

NOTE: Interlaced signals (480i, 576i, 1080i) are not supported. If you have any problems, please refer to the Troubleshooting section of this User's Manual.

VIDEO DETECT

Selects the method of video detection when more than one video input is connected.

FIRST: When current video input signal is not present, then the monitor searches for a video signal from the other video input port. If the video signal is present in the other port, then the monitor switches the video source input port to the new found video source automatically. The monitor will not look for other video signals while the current video source is present.

LAST: When the monitor is displaying a signal from the current source and a new secondary source is supplied to the monitor, then the monitor will automatically switch to the new video source. When current video input signal is not present, then the monitor searches for a video signal from the other video input port. If the video signal is present in the other port, then the monitor switches the video source input port to the new found video source automatically.

NONE: The Monitor will not search the other video input port unless the monitor is turned on.

OFF TIMER

Monitor will automatically power-down when the end user has selected a pre-determined amount of time.

Before powering off, a message will appear on the screen asking the user if they want to delay the turn off time by 60 minutes. Press any OSD button to delay the turn off time.

OFF MODE

This function allows the monitor to enter into a power saving mode after a period of inactivity.

The OFF MODE has three settings.

OFF: Monitor does not go into power save mode when the input signal is lost.

STANDARD: Monitor enters power save mode automatically when the input signal is lost.

OPTION: Monitor enters power save mode automatically when the amount of surrounding light goes below the a level that is determined by the user. The level can be adjusted in Tag7 of the Advanced OSD Control menu.

When in power save mode, the LED on the front of the monitor blinks amber. While in power save mode, push any of the front buttons, except for POWER and SELECT to return to normal.

When the amount of surrounding light returns to normal levels, the monitor will automatically return to normal mode.

UNIFORMITY

This function electronically compensates for the slight variations in the white uniformity level, as well as for deviations in color that may occur throughout the display area of the screen. These variations are characteristic of LCD panel technology. This function improves the color and evens out the luminance uniformity of the display. Settings from 1 to 5 are available. 1 is the lowest amount of compensation and 5 is the highest.

NOTE: Using the UNIFORMITY feature reduces the overall peak luminance of the display. If greater luminance is desired over the uniform performance of the display, then UNIFORMITY should be turned off.



MENU Tools

LANGUAGE

OSD control menus are available in eight languages.

OSD LEFT/RIGHT

You can choose where you would like the OSD control image to appear on your screen. Selecting OSD Location allows you to manually adjust the position of the OSD control menu left or right.

OSD DOWN/UP

You can choose where you would like the OSD control image to appear on your screen. Selecting OSD Location allows you to manually adjust the position of the OSD control menu Up or Down.

OSD TURN OFF

The OSD control menu will stay on as long as it is use. You can select how long the monitor waits after the last touch of a button to shut off the OSD control menu. The preset choices are 10-120 seconds by 5-second increments.

OSD LOCK OUT

This control completely locks out access to all OSD control functions. When attempting to activate OSD controls while in the Lock Out mode, a screen will appear indicating the OSD controls are locked out.

There are four types of OSD LOCK OUT:

OSD LOCK OUT with BRIGHTNESS and CONTRAST control: To activate the OSD Lock Out function, press SELECT, then the “UP” button and hold down simultaneously. To deactivate the OSD Lock Out, press SELECT, then the “UP” button and hold down simultaneously while in the OSD menu. BRIGHTNESS and CONTRAST can be adjusted while in this lock out mode.

OSD LOCK OUT with no control: To activate the OSD Lock Out function, press SELECT, then the “Right” button and hold down simultaneously. To deactivate the OSD Lock Out, press SELECT, then the “Right” button and hold down simultaneously while in the OSD menu. No controls can be adjusted while in this lock out mode.

OSD LOCK OUT with BRIGHTNESS (only) control: To activate the OSD Lock Out function, press SELECT, then the “Down” and “Left” buttons and hold down simultaneously. To deactivate the OSD Lock Out, press SELECT, then the “Down” and “Left” buttons and hold down simultaneously while in the OSD menu. Only the BRIGHTNESS can be adjusted while in this lock out mode.

CUSTOM: Refer to the Advanced OSD Menu.

OSD TRANSPARENCY

Adjusts the transparency of the OSD Menu.

OSD COLOR

“Tag window frame color”, “Item select color” and “Adjust window frame color” can be changed to Red, Green, Blue, or Gray.

RESOLUTION NOTIFIER

This optimal resolution is 2560 x 1600. If ON is selected, a message will appear on the screen after 30 seconds, notifying you that the resolution is not at 2560 x 1600.

HOT KEY

You can adjust the BRIGHTNESS and CONTRAST directly. When this function is set to ON, you can adjust the brightness with the “Left” or “Right” buttons, and the contrast with the “Down” or “Up” buttons, while the OSD menu is off. The standard OSD can be accessed with the EXIT button.

FACTORY PRESET

Selecting Factory Preset allows you to reset all OSD control settings (BRIGHTNESS, CONTRAST, ECOMODE, AUTO BRIGHTNESS, BLACK LEVEL, IMAGE CONTROL, COLOR CONTROL SYSTEM, SHARPNESS, OFF TIMER, OFF MODE, OSD LEFT/RIGHT, OSD UP/DOWN, OSD TURN OFF, OSD TRANSPARENCY) back to the factory settings. Individual settings can be reset by highlighting the control to be reset and pressing the RESET button.



Information

Provides information about the current resolution display and technical data including the preset timing being used and the horizontal and vertical frequencies. Indicates the model and serial numbers of your monitor.

NOTE: When connected to digital input, the OSD will show either DIGITAL(D) if a dual link signal is detected or DIGITAL(S) if a single link signal is detected.

OSD Warning

OSD Warning menus disappear with Exit button.

NO SIGNAL: This function gives a warning when there is no Horizontal or Vertical Sync. After power is turned on or when there is a change of input signal, the **No Signal** window will appear.

RESOLUTION NOTIFIER: This function warns if resolution other than the optimized resolution is used. After power is turned on or when there is a change of input signal or the video signal doesn't have proper resolution, the **Resolution Notifier** window will open. This function can be disabled in the MENU Tools OSD.

OUT OF RANGE: This function gives a recommendation of the optimized resolution and refresh rate. After the power is turned on or there is a change of input signal or if the video signal doesn't have proper timing, the **Out Of Range** menu will appear.

PORTRAIT WARNING: When the monitor is used in the portrait position, the brightness value will be reduced to 300 cd/m². If the Portrait Warning is ON, a message warning of the change in brightness will appear on the screen for 10 seconds.

LUMINANCE WARNING: When the backlight cannot display the desired luminance, a message will appear on the display. To avoid this, reduce the BRIGHTNESS level or set the AUTO LUMINANCE function to OFF (page 18, TAG1).

NOTE: It is possible to change the DVI SELECTION, to change the OFF MODE or to change the HDCP CONTENT settings while the “NO SIGNAL” or “OUT OF RANGE” messages are displayed.

For advanced user menu see “Appendix”.

Specifications

Monitor Specifications	MultiSync LCD3090WQXi Monitor	Notes
LCD Module Diagonal: Viewable Image Size: Native Resolution (Pixel Count):	75.6 cm/29.8 inches 75.6 cm/29.8 inches 2560 x 1600	Active matrix; thin film transistor (TFT) liquid crystal display (LCD); 0.251 mm dot pitch; 350 cd/m ² *2 white luminance; 1000:1*2 contrast ratio, typical.
Input Signal	Video: Sync: ANALOG 0.7 Vp-p/75 Ohms Separate sync.TTL Level Horizontal sync. Positive/Negative Vertical sync. Positive/Negative Composite sync. Positive/Negative Sync on Green (Video 0.7V p-p and Sync Negative 0.3V p-p)	Digital Input: DVI (with HDCP)
Display Colors	16,777,216	Depends on display card used.
Synchronization Range	Horizontal: Vertical: 24.0 kHz to 93.8 kHz (Analog) 31.5 kHz to 98.7 kHz (Digital) 24.0 Hz to 85 Hz	Automatically Automatically Automatically
Viewing Angle	Left/Right: Up/Down: ±89° (CR > 10) ±89° (CR > 10)	
Image Formation Time	12 ms (Typ.)	6 ms (Gray to gray Typ)
Resolutions Supported (Some systems may not support all modes listed).	640 x 400*1 at 56 Hz (Analog) 640 x 480*1 at 60 Hz to 85 Hz 720 x 350*1 at 70 Hz to 85 Hz 720 x 400*1 at 70 Hz to 85 Hz 800 x 600*1 at 56 Hz to 85 Hz 832 x 624*1 at 75 Hz 1024 x 768*1 at 60 Hz to 85 Hz 1125 x 870*1 at 75 Hz 1152 x 900*1 at 66 Hz 1280 x 800*1 at 60 Hz 1280 x 960*1 at 60 Hz to 85 Hz 1280 x 1024*1 at 60 Hz to 85 Hz 1400 x 1050*1 at 60 Hz to 75 Hz 1440 x 900*1 at 60 Hz to 85 Hz 1600 x 1200*1 at 60 Hz to 75 Hz (Analog), at 60 Hz (Digital) 1680 x 1050*1 at 75 Hz (Analog) 1920 x 1200*1 at 60 Hz 1920 x 1440*1 at 60 Hz (Digital) 2560 x 1600 at 30 Hz 2560 x 1600 at 60 Hz (Digital)..... 480P (720 x 480*1 at 60 Hz) 576P (720 x 576*1 at 50 Hz) 720P (1280 x 720*1 at 50 Hz to 60 Hz) 1080P (1920 x 1080*1 at 50 Hz to 60 Hz)	NEC DISPLAY SOLUTIONS cites recommended resolution for optimal display performance.
Active Display Area	Landscape: Horiz.: Vert.: Portrait: Horiz.: Vert.: 641 mm/25.2 inches 401 mm/15.8 inches 401 mm/15.8 inches 641 mm/25.2 inches	
Power Supply	AC 100-240 V ~ 50/60 Hz	
Current Rating	1.76-0.77A (with option)	For reference 1.6A (without option) For Mexico 2.0A
Dimensions	Landscape: Portrait: Height Adjustment: 687.3 mm (W) x 478.6 - 668.6 mm (H) x 342.8 mm (D) 27.1 inches (W) x 18.8 - 26.3 inches (H) x 13.5 inches (D) 446.8 mm (W) x 703.5 - 788.9 mm (H) x 342.8 mm (D) 17.6 inches (W) x 27.7 - 31.1 inches (H) x 13.5 inches (D) 190 mm / 7.5 inches	
Weight	19.1 kg (42.0 lbs)	
Environmental Considerations	Operating Temperature: Humidity: Altitude: Storage Temperature: Humidity: Altitude: 5°C to 35°C/41°F to 95°F 30% to 80% 0 to 9,842 Feet/0 to 3,000 m -10°C to 60°C/14°F to 140°F 10% to 85% 0 to 40,000 Feet/0 to 12,192 m	

*1 Interpolated Resolutions: When resolutions are shown that are lower than the pixel count of the LCD module, text may appear different. This is normal and necessary for all current flat panel technologies when displaying non-native resolutions full screen. In flat panel technologies, each dot on the screen is actually one pixel, so to expand resolutions to full screen, an interpolation of the resolution must be done.

*2 Condition: UNIFORMITY is OFF.

NOTE: Technical specifications are subject to change without notice.

Features

DVI-I: The integrated interface ratified by the Digital Display Working Group (DDWG) that allows both digital and analog connectors off of one port. The "I" stands for integration for both digital and analog, The digital portion is DVI-based.

DVI-D: The digital-only subset of DVI ratified by the Digital Display Working Group (DDWG) for digital connections between computers and displays. As a digital-only connector, analog support is not provided off a DVI-D connector. As a DVI-based digital only connection, only a simple adapter is necessary for compatibility between DVI-D and other DVI-based digital connectors such as DFP and P&D.

DFP (Digital Flat Panel): An all-digital interface for flat panel monitors which is signal compatible with DVI. As a DVI-based digital only connection, only a simple adapter is necessary for compatibility between DFP and other DVI-based digital connectors such as DVI and P&D.

P&D (Plug and Display): The VESA standard for digital flat panel monitor interfaces. It is more robust than DFP since it allows for other options off a signal connector (options like USB, analog video and IEEE-1394-995). The VESA committee has recognized that DFP is a subset of P&D. As a DVI-based connector (for the digital input pins), only a simple adapter is necessary for compatibility between P&D and other DVI-based digital connector such as DVI and DFP.

Pivoting Stand: Allows users to adjust the monitor to the orientation that best fits their application, either Landscape orientation for wide documents, or portrait orientation for the ability to preview a full page on one screen at one time. The Portrait orientation is also perfect for full screen video conferencing.

Reduced Footprint: Provides the ideal solution for environments requiring superior image quality but with size and weight limitations. The monitor's small footprint and low weight allow it to be moved or transported easily from one location to another.

Color Control Systems: Allows you to adjust the colors on your screen and customize the color accuracy of your monitor to a variety of standards.

Natural color matrix: Combines Six-axis color control and the sRGB standard. Six-axis color control permits color adjustments via six axes (R, G, B, C, M and Y) rather than through the three axes (R, G and B) previously available. The sRGB standard provides the monitor with a uniform color profile. This assures that the colors displayed on the monitor are exactly the same as on the color printout (with sRGB supporting operating system and sRGB printer). This allows you to adjust the colors on your screen and customise the color accuracy of your monitor to a variety of standards.

OSD (On-Screen Display) Controls: Allow you to quickly and easily adjust all elements of your screen image via simple to use on-screen menus.

ErgoDesign Features: Enhanced human ergonomics to improve the working environment, protect the health of the user and save money. Examples include OSD controls for quick and easy image adjustments, tilt base for preferred angle of vision, small footprint and compliance with MPRII and TCO guidelines for lower emissions.

Plug and Play: The Microsoft® solution with the Windows® operating system facilitates setup and installation by allowing the monitor to send its capabilities (such as screen size and resolutions supported) directly to your computer, automatically optimizing display performance.

Intelligent power management System: Provides innovative power-saving methods that allow the monitor to shift to a lower power consumption level when on but not in use, saving two-thirds of your monitor energy costs, reducing emissions and lowering the air conditioning costs of the workplace.

Multiple Frequency Technology: Automatically adjusts monitor to the display card's scanning frequency, thus displaying the resolution required.

FullScan Capability: Allows you to use the entire screen area in most resolutions, significantly expanding image size.

Wide Viewing Angle Technology: Allows the user to be able to see the monitor from any angle (178°) from any orientation — Portrait or Landscape. Provides full 178° viewing angles either up, down, left or right.

VESA Standard Mounting Interface: Allows users to connect their MultiSync monitor to any VESA-standard third party mounting arm or bracket. Allows for the monitor to be mounted on a wall or an arm using any third party compliant device.

Visual Controller: Is a ground-breaking software family, developed by NEC Display Solutions Europe GmbH, providing intuitive access to all monitor setting controls and remote diagnosis via the Windows interface, based upon the VESA standard, DDC/CI. Using a standard VGA or DVI signal cable, Visual Controller can either benefit single users or, with Visual Controller Administrator, can reduce the Total Cost of Ownership through remote network-wide maintenance, diagnosis and asset-reporting.

CableComp automatic long cable compensation prevents image quality degradation caused by long cable lengths.

No-touch Auto Adjust (Analog input only): No-touch auto adjust automatically adjusts the monitor to optimal settings upon initial setup.

sRGB Color Control: A new optimized color management standard which allows for color matching on computer displays and other peripherals. The sRGB, which is based on the calibrated color space, allows for optimal color representation and backward compatibility with other common color standards.

UNIFORMITY: This feature compensates for slight variations in the white uniformity level that may occur on the screen and improves the color and evens out the luminance uniformity of the display.

Response Improve: Improved gray to gray response.

Adjustable stand with pivot capability: Adds flexibility to your viewing preferences.

Quick Release stand: Allows fast removal.

Auto dimming technology: Automatically adjusts the backlight level depending on the level of ambient lighting.

AUTO LUMINANCE: Turns on the built-in backlight sensor, the AUTO LUMINANCE function can be used to maintain a selected level of light output as well as correcting for short-term fluctuations. AUTO LUMINANCE also brings the display up to optimum output soon after powering on. This application is especially useful for displays that will be calibrated. When auto luminance is enabled the display will reduce the output brightness to a preset level and the OSD will indicate the luminance level in estimated candelas per meter squared (cd/m²).

Troubleshooting

No picture

- The signal cable should be completely connected to the display card/computer.
- The display card should be completely seated in its slot.
- Check the Vacation Switch should be in the ON position.
- Front Power Switch and computer power switch should be in the ON position.
- Check to make sure that a supported mode has been selected on the display card or system being used. (Please consult display card or system manual to change graphics mode.)
- Check the monitor and your display card with respect to compatibility and recommended settings.
- Check the signal cable connector for bent or pushed-in pins.
- Check the signal input, "DVI-D" or "DVI-I".
- Ensure the DVI input mode is set to DIGITAL when the MAC digital output is connected to the DVI-I connector.
- If the front LED is blinking amber, check the status of the OFF MODE mode (see page 13).
- When using a DVD player or any other type of high-definition device, please do not use interlaced signals. If the monitor detects an interlaced signal, an OSD warning will appear. If this OSD warning appears, please do the following: press the RESET and EXIT buttons simultaneously, to temporarily show the image coming from the high-definition device. While the image is visible, change the signal of the device from interlaced to progressive (non-interlaced). Consult the User's Manual included with the device for detailed information on changing the signal from interlaced to progressive.

Power Button does not respond

- Unplug the power cord of the monitor from the AC outlet to turn off and reset the monitor.
- Check the Vacation Switch on the left side of the monitor.

Image Persistence

- Image persistence is when a residual or "ghost" image of a previous image remains visible on the screen. Unlike CRT monitors, LCD monitors' image persistence is not permanent, but constant images being displayed for a long period of time should be avoided. To alleviate image persistence, turn off the monitor for as long as the previous image was displayed. For example, if an image was on the monitor for one hour and a residual image remains, the monitor should be turned off for one hour to erase the image.

NOTE: As with all personal display devices, NEC DISPLAY SOLUTIONS recommends using a moving screen saver at regular intervals whenever the screen is idle or turning off the monitor when not in use.

Message "OUT OF RANGE" is displayed (screen is either blank or shows rough images only)

- Image is displayed only roughly (pixels are missing) and OSD warning "OUT OF RANGE" is displayed: Either signal clock or resolution is too high. Choose one of the supported modes.
- OSD warning "OUT OF RANGE" is displayed on a blank screen: Signal frequency is out of range. Choose one of the supported modes.

Image is unstable, unfocused or swimming is apparent

- Signal cable should be completely attached to the computer.
- Use the OSD Image Adjust controls to focus and adjust display by increasing or decreasing the FINE adjustment. When the display mode is changed, the OSD Image Adjust settings may need to be readjusted.
- Check the monitor and your display card with respect to compatibility and recommended signal timings.
- If your text is garbled, change the video mode to non-interlaced and use 60Hz refresh rate.

LED on monitor is not lit (*no green, blue or amber color can be seen*)

- Power Switch should be in the ON position and power cord should be connected.

Picture is not as bright

- Make sure ECO MODE, AUTO BRIGHTNESS, and UNIFORMITY functions are turned off.
- If the brightness fluctuates make sure AUTO BRIGHTNESS is turned off.

Display image is not sized properly

- Use the OSD Image Adjust controls to increase or decrease the Coarse adjustment.
- Check to make sure that a supported mode has been selected on the display card or system being used. (Please consult display card or system manual to change graphics mode.)

No Video

- If no video is present on the screen, turn the Power button off and on again.
- Make certain the computer is not in a power-saving mode (touch the keyboard or mouse).

Self Diagnosis

- The LCD display is equipped with the ability to self diagnose abnormalities. When the LCD detects a problem, the LED on the front flashes in a pattern of long and short blinks, depending on the type of problem detected.
- If the LED detects a problem, please refer service to qualified personnel.

Appendix

If you need detailed information about the controls, please use the advanced menu.

<How to use the advanced menu>

- Turn off your monitor.
- Turn on your monitor by pushing the “POWER” and “SELECT” button at the same time for at least one second simultaneously. Then press the control buttons (EXIT, LEFT, RIGHT, UP, DOWN).
- You will see the Advanced menu.
This menu is larger than the normal OSD.

<How to exit the advanced menu>

- Turn off and restart your monitor in the normal way.

To make an adjustment, ensure that the tag is highlighted, then press “SELECT”.

To move to another tag, press “EXIT”, then press “Left” or “Right” to highlight another tag.

Tag1	Brightness	Adjusts the overall image and screen background brightness. Press “Left” or “Right” to adjust. When AUTO LUMINANCE is OFF or 2, the brightness level is adjusted/measured using percentage (%). When AUTO LUMINANCE is 1 or 3, brightness level is adjusted/measured using cd/m ² . This is the “Estimated Brightness” level. Note: The upper portion (higher settings) of the brightness level is adjusted using the backlight output. If a very low brightness level (low setting) is used the contrast level may be reduced. The display will digitally compensate for low brightness level. If this occurs, the indicator on the OSD will turn magenta.
	Contrast	Adjusts the image brightness and contrast in relation to the background. Press “Left” or “Right” to adjust.
	Auto Contrast (Analog input only)	Adjusts the image displayed for non-standard video inputs. Press “SELECT” to adjust. Any adjustment requires the image to have white portions.
	Auto Black Level (Analog input only)	Automatically adjusts the black level. Any adjustment requires the image to have black portions. Press “SELECT” to activate Auto Adjust.
	ECO Mode	Decreases the amount of power consumed by reducing the brightness level. 1: Decreases the brightness by 25%. 2: Decreases the brightness by 50%. CUSTOM: Decreases the brightness level as determined by the user.
	ECO Mode Custom	Allows the user to set a preferred brightness level when ECO Mode is in use.
	Auto Brightness	Auto Brightness has three settings. OFF: No function. 1: Adjusts the brightness automatically, by detecting the brightness level of your environment and adjusting the monitor with your BRIGHTNESS setting. 2: Adjusts the brightness automatically for the best BRIGHTNESS setting based on the white display area. The environmental brightness sensor (Auto dimming sensor) has no function. Note: Do not cover environmental brightness sensor (Auto dimming sensor). When “AUTO LUMINANCE” is ON, this function is disabled.
	Black Level	Allows you to manually adjust the black level. Press “Left” or “Right” to adjust.
	AUTO LUMINANCE	Stabilizes the luminosity and color of the image. While the BRIGHTNESS level is adjusting, the numerical value blinks. OFF: No function 1: Stabilize Luminance 2: Stabilize Color 3: Stabilize Luminance and color Note: The AUTO LUMINANCE function is only available when “AUTO BRIGHTNESS” is OFF. When AUTO LUMINANCE is 1 or 3, maximum value of the Brightness level is limited. When AUTO LUMINANCE is OFF or 2, the brightness level is adjusted/measured using percentage (%). When AUTO LUMINANCE is 1 or 3, brightness level is adjusted/measured using cd/m ² . This is the “Estimated Brightness” level.

Tag2	R-H.position (Analog input only)	Adjusts the position of the red component of the image. Press "Left" or "Right" to adjust.																			
	G-H.position (Analog input only)	Adjusts the position of the green component of the image. Press "Left" or "Right" to adjust.																			
	B-H.position (Analog input only)	Adjusts the position of the blue component of the image. Press "Left" or "Right" to adjust.																			
	R-FINE (Analog input only)	Adjusts the "FINE" setting of the RED component of the image. Press "Left" or "Right" to adjust.																			
	G-FINE (Analog input only)	Adjusts the "FINE" setting of the GREEN component of the image. Press "Left" or "Right" to adjust.																			
	B-FINE (Analog input only)	Adjusts the "FINE" setting of the BLUE component of the image. Press "Left" or "Right" to adjust.																			
	R-SHARPNESS (Analog input only)	Adjusts the sharpness of the red component of the image. Press "Left" or "Right" to adjust.																			
	G-SHARPNESS (Analog input only)	Adjusts the sharpness of the green component of the image. Press "Left" or "Right" to adjust.																			
	B-SHARPNESS (Analog input only)	Adjusts the sharpness of the blue component of the image. Press "Left" or "Right" to adjust.																			
	DVI Long Cable (Digital input only)	Compensates for image degradation caused by using a long DVI cable. There are 4 possible settings, with "0" being the lowest level of compensation and "3" being the highest level. The default setting is "1".																			
Tag3	Auto Adjust (Analog input only)	Automatically adjusts the Image Position and H.Size settings and Fine settings. Press "SELECT" to activate Auto Adjustment.																			
	Signal Adjust (Analog input only)	Determines when the auto adjustment is activated automatically. The choices are "SIMPLE" and "FULL". Press "Left" or "Right" to select. <table border="1" data-bbox="513 1003 963 1099"> <thead> <tr> <th></th> <th>H-size, Fine, H/V Position</th> <th>Contrast</th> </tr> </thead> <tbody> <tr> <td>SIMPLE</td> <td style="text-align: center;">O</td> <td style="text-align: center;">X</td> </tr> <tr> <td>FULL</td> <td style="text-align: center;">O</td> <td style="text-align: center;">O</td> </tr> </tbody> </table> <p>O: Automatic Adjustment X: No Automatic Adjustment NOTE: Automatic Adjustment does not work at resolutions less than 800x600 resolution.</p>		H-size, Fine, H/V Position	Contrast	SIMPLE	O	X	FULL	O	O										
		H-size, Fine, H/V Position	Contrast																		
	SIMPLE	O	X																		
FULL	O	O																			
Auto Adjust Level (Analog input only)	Determines the automatic adjustment level for Auto Adjust. The choices are "SIMPLE", "FULL" and "DETAIL". Press "Left" or "Right" to select. Refer to the below table. <table border="1" data-bbox="513 1238 1353 1379"> <thead> <tr> <th></th> <th>Size, Fine, Position</th> <th>Contrast</th> <th>Black Level, Long cable capability**</th> <th>Time</th> </tr> </thead> <tbody> <tr> <td>SIMPLE</td> <td style="text-align: center;">O</td> <td style="text-align: center;">X</td> <td style="text-align: center;">X</td> <td style="text-align: center;">1 second</td> </tr> <tr> <td>FULL</td> <td style="text-align: center;">O</td> <td style="text-align: center;">O</td> <td style="text-align: center;">X</td> <td style="text-align: center;">1.5 seconds</td> </tr> <tr> <td>DETAIL*</td> <td style="text-align: center;">O</td> <td style="text-align: center;">O</td> <td style="text-align: center;">O</td> <td style="text-align: center;">5 seconds</td> </tr> </tbody> </table> <p>O: Automatic Adjustment X: No Automatic Adjustment * "DETAIL" activates automatic long cable (skew, peaking) adjustment. ** Black level, RGB sharpness, RGB delay and RGB position are adjusted using "Long cable software" which is included in the attached CD-ROM.</p>		Size, Fine, Position	Contrast	Black Level, Long cable capability**	Time	SIMPLE	O	X	X	1 second	FULL	O	O	X	1.5 seconds	DETAIL*	O	O	O	5 seconds
	Size, Fine, Position	Contrast	Black Level, Long cable capability**	Time																	
SIMPLE	O	X	X	1 second																	
FULL	O	O	X	1.5 seconds																	
DETAIL*	O	O	O	5 seconds																	
A-NTAA SW (Analog input only)	The Advanced No Touch Auto Adjust function is able to recognize new signals even when neither the resolution nor the refresh rate has changed. If several PCs are connected to the monitor, and each transmit very similar (or even the same) signals in terms of resolution and refresh rates, the monitor recognizes that there is a new signal and automatically optimizes the picture without the need for any action on the part of the user. OFF: A-NTAA is disabled. ON: If a change in signal is detected A-NTAA will adjust the monitor to the optimal settings for the new signal. If no change in the signal is detected then A-NTAA does not activate. The screen will be blank while the monitor optimizes the signal. OPTION: Functions the same as ON, except that the screen does not go blank when the monitor makes adjustments for changes in signal, allowing the monitor to display the new signal faster. When using an external switching device to connect 2 or more PCs to the monitor, using the ON or OPTION settings is suitable.																				
Tag4	H. Position	Controls Horizontal Image Position within the display area of the LCD. Press "Left" or "Right" to adjust.																			
	V. Position	Controls Vertical Image Position within the display area of the LCD. Press "Left" or "Right" to adjust.																			

	H. Size (Analog input only)	Adjusts the horizontal size of the screen. If the "AUTO Adjust function" do not give you a satisfactory picture setting, a further tuning can be performed using the "H.Size (V.Size)" function (dot clock). For this a Moiré test pattern could be used. This function may alter the width of the picture. Use left/Right Menu to center the image on the screen. If the H.Size (V.Size) is wrongly calibrated, the result would look like the left drawing. The image should be homogeneous.
	Fine (Analog input only)	Improve focus, clarity and image stability by increasing or decreasing this setting. If the "Auto Adjust function" and the "H.Size" function do not give you a satisfactory picture setting, a fine tuning can be performed using the "Fine" function. For this a Moiré test pattern could be used. If the Fine value is wrongly calibrated, the result would look like the left drawing. The image should be homogeneous.
	Auto Fine (Analog input only)	This function automatically and periodically adjusts the "FINE" setting for change in signal condition. This function adjusts approximately every 33 minutes.
	H. Resolution	Adjusts the horizontal size by increasing or decreasing the setting. Press "Right" button to expand the width of the image on the screen. Press "Left" button to narrow the width of the image on the screen.
	V. Resolution	Adjusts the vertical size by increasing or decreasing the setting. Press "Right" button to expand the height of the image on the screen. Press "Left" button to narrow the height of the image on the screen.
	Expansion	Sets the zoom method. FULL: The image is expanded to 2560 x 1600, regardless of the resolution. ASPECT: The image is expanded without changing the aspect ratio. OFF: The image is not expanded. CUSTOM: When CUSTOM is selected as the Expansion mode, it becomes possible to adjust the H. ZOOM., V. ZOOM, and ZOOM POS.
	H.ZOOM (Available in Custom Expansion mode only)	The image is expanded from 1 to 3 times in the horizontal (H. EXPANSION) direction by 0.01 increments.
	V.ZOOM (Available in Custom Expansion mode only)	The image is expanded from 1 to 3 times in the vertical (V. EXPANSION) direction by 0.01 increments.
	ZOOM POS. (Available in Custom Expansion mode only)	Sets the point from which the screen will be expanded when either H.ZOOM or V.ZOOM is selected as the expansion method. Options are CENTER and LEFT TOP. CENTER: H.ZOOM expands the image from the centre outward to the sides of the screen. V.ZOOM expands the image from the centre towards the top and bottom of the screen. LEFT TOP: Indicates the set point for image expansion (TOP in V. Zoom, LEFT in H.ZOOM). If the resolution does not fill out the screen, when expanding, the image will not expand past the TOP or the LEFT of the screen. The image can be expanded past the right and bottom edges of the screen.
Tag5	Gamma Selection	Allows you to manually select (Gamma function*) the brightness level of grayscale. There are five selections: NO CORRECTION, 2.2, OPTION, PROGRAMMABLE and CUSTOM. NO CORRECTION: No Correction possible. 2.2: The value is fixed at 2.2. PRIORITY: Please refer to the explanation in the CUSTOM selection below. OPTION: There are two ways of OPTION selection. 1: This setting is recommended for Video source. Gray area looks much brighter than NO CORRECTION setting. 2: DICOM gamma is recommended for grayscale medical images. Factory calibrated to DICOM Grayscale Display Function for optimum human visual perception. PROGRAMMABLE: A programmable gamma curve can be loaded using NEC software. CUSTOM: Below items can be adjusted when CUSTOM is selected as the GAMMA SELECTION setting. Custom Value: The gamma value ranges between 0.5 to 4.0 in 0.1 increments. When the COLOR CONTROL is sRGB, the value is fixed at 2.2 and NOT ADJUSTABLE. Offset: The OFFSET digitally adjusts the black level after the signal is converted from analog to digital. PRIORITY: Sets gamma characteristics for optimum viewing of grayscale or color. GRAYSCALE: Optimizes gamma for grayscale imaging –should be used with DICOM. COLOR: Optimizes gamma for color images. *Gamma - The way brightness is distributed across the intensity spectrum by a monitor, Gamma is relationship between the input voltage and resulting intensity of the output. A perfect linear device would have a gamma of 1.0. A gamma correction function is used to alter the luminance (light intensity) of a display such that its brightness (the human-perceived value) appears correct.

Tag6	Color Control	<p>Color Control Systems: Seven preset color settings. For preset settings 1, 2, 3 and 5, the following levels can be adjusted: TEMPERATURE: Adjust the white temperature by increasing or decreasing this setting. A lower color temperature will make the screen reddish and a higher color temperature will make the screen bluish. WHITE (White Balance): If TEMPERATURE needs further adjustment; the individual R/ G/ B/ levels of the white point can be adjusted. To adjust the R/G/B levels, CUSTOM must be showing as the TEMPERATURE selection. HUE: Adjusts the hue of each color*¹. The change in color will appear on screen and the menu color bars will show the amount of adjustment. SATURATION: Adjusts the color depth of each color*¹. Press the “RIGHT” button and the color vividness increases. OFFSET: Adjusts the color brightness of each color*¹. Press “RIGHT” button and the color Brightness increases. *¹: RED, YELLOW, GREEN, CYAN, BLUE and MAGENTA. NATIVE, sRGB: Original color presented by the LCD panel that is unadjustable. PROGRAMMABLE: The color tone that was set up with the special application software is reflected.</p>
Tag7	Sharpness	<p>This is a digital capability for keeping a crisp image at all signal timings. It continuously adjusts to maintain as distinct or as soft an image as you prefer and is set independently according to different timings. Press “Left” or “Right” to adjust.</p>
	DVI Selection	<p>This function selects the DVI input mode. When the DVI selection has been changed, you must restart your computer. Press “Left” or “Right” to select. AUTO: By using the DVI-D to DVI-D cable, the DVI SECTION is DIGITAL. By using the D-SUB to DVI-A cable, the DVI SECTION is ANALOG. DIGITAL: DVI digital input is available. ANALOG: DVI analog input is available.</p>
	HDCP CONTENT (Digital Input Only)	<p>Selects the type of input to be used with HDCP CONTENT. OFF: When a PC or other computer equipment is connected, select “OFF”. ON: When a DVD player or other type of high definition device is connected, select “ON”. Note: Interlaced signals (480i, 576i, 1080i) are not supported. If you have any problems, please refer to the Troubleshooting section of this User’s Manual.</p>
	Video Detect	<p>Selects the method of video detection when more than one computer is connected. Press “Left” or “Right” to select. FIRST: When current video input signal is not present, then the monitor searches for a video signal from the other video input port. If the video signal is present in the other port, then the monitor switches the video source input port to the new found video source automatically. The monitor will not look for other video signals while the current video source is present. LAST: When the monitor is displaying a signal from the current source and a new secondary source is supplied to the monitor, then the monitor will automatically switch to the new video source. When current video input signal is not present, then the monitor searches for a video signal from the other video input port. If the video signal is present in the other port, then the monitor switches the video source input port to the new found video source automatically. NONE: The Monitor will not search the other video input port unless the monitor is turned on.</p>
	Off Timer	<p>Monitor will automatically turn off after the preset time period from power on with the ON/OFF function. When you select “ON”, press “SELECT” and “Left” or “Right” to adjust. Before powering off, a message will appear on the screen asking the user if they want to delay the turn off time by 60 minutes. Press any OSD button to delay the turn off time.</p>
	OFF MODE	<p>This function allows the monitor to enter into a power saving mode after a period of inactivity. The OFF MODE has three settings. OFF: Monitor does not go into power save mode when the input signal is lost. STANDARD: Monitor enters power save mode automatically when the input signal is lost. OPTION: Monitor enters power save mode automatically when the amount of surrounding light goes below the level that is determined by the user.</p>
	OFF MODE Setting	<p>Adjusts the ILLUMINANCE value for OFF MODE.</p>

	Response Improve	Turns the RESPONSE IMPROVE function on or off. Response Improve may reduce blurring that occurs in some moving images. When Response Improve is on, response time is improved.
	Side Border Color	Adjusts the side black bars color between black and white. For wide aspect monitors.
	LED Brightness	Controls the brightness of the LED on the monitor.
	LED Color	The LED on the front can be blue or green.
	UNIFORMITY	This function electronically compensates for the slight variations in the white uniformity level as well as for deviations in color that may occur throughout the display area of the screen. These variations are characteristic of LCD panel technology. This function improves the color and evens out the luminance uniformity of the display. Settings from 1 to 5 are available. 1 is the lowest amount of compensation and 5 is the highest. NOTE: Using the UNIFORMITY feature does reduce the overall peak luminance of the display. If greater luminance is desired over the uniform performance of the display, then UNIFORMITY should be turned off.
	UNIFORMITY Level	Select the level for UNIFORMITY adjustments.
Tag8	Language	OSD control menus are available in eight languages. Press "Left" or "Right" to select.
	OSD H. Position	You can choose where you would like the OSD control image to appear on your screen. Selecting OSD Location allows you to manually adjust the position of the OSD control menu left or right.
	OSD V. Position	You can choose where you would like the OSD control image to appear on your screen. Selecting OSD Location allows you to manually adjust the position of the OSD control menu up or down.
	OSD Turn off	The OSD control menu will stay on as long as it is use. You can select how long the monitor waits after the last touch of a button to shut off the OSD control menu. The preset choices are 10-120 seconds by 5 seconds step.
	OSD Lock Out	This control completely locks out access to all OSD control functions. When attempting to activate OSD controls while in the Lock Out mode, a screen will appear indicating the OSD controls are locked out. There are three types of OSD LOCK OUT: OSD LOCK OUT with BRIGHTNESS and CONTRAST control: To activate the OSD Lock Out function, press SELECT, then "UP" button and hold down simultaneously. To deactivate the OSD Lock Out, press SELECT, then "UP" button and hold down simultaneously while in the OSD menu. BRIGHTNESS and CONTRAST can be adjusted while in the lock out mode. OSD LOCK OUT with no control: To activate the OSD Lock Out function, press SELECT, then "Right" button and hold down simultaneously. To deactivate the OSD Lock Out, press SELECT, then "Right" button and hold down simultaneously while in the OSD menu. No controls can be adjusted while in the lock out mode. OSD LOCK OUT with BRIGHTNESS (only) control: To activate the OSD Lock Out function, press SELECT, then "Down" and "Left" buttons and hold down simultaneously. To deactivate the OSD Lock Out, press SELECT, then "Down" and "Left" buttons and hold down simultaneously while in the OSD menu. BRIGHTNESS can be adjusted while in the lock out mode. CUSTOM: Press RESET and EXIT to enter the CUSTOM Menu. Select ENABLE or DISABLE for POWER KEY, INPUT SEL, HOT KEY (BRIGHTNESS/CONTRAST), ECO MODE, WARNING (RESOLUTION NOTIFIER/OSD LOCK OUT). To Deactivate the OSD Lock Out function, press RESET and EXIT to bring up the LOCK OUT warning. Press SELECT, SELECT, LEFT, RIGHT, LEFT, RIGHT, EXIT.
	OSD Transparency	Adjusts the transparency of the OSD MENU.
	OSD Color	"Tag window frame color", "Item select color" & "Adjust Window frame color" can be changed.
	BOOT LOGO	The NEC logo is briefly displayed after the monitor is powered on. This feature can be turned on or off in the OSD. Note: If the "EXIT" button is kept pressed while NEC logo is displayed, the BOOT LOGO menu will appear. It is possible to change the BOOT LOGO setting to OFF.
	Signal Information	Signal information can be displayed in the corner of the screen. Signal information is either "On/Off".
	Resolution Notifier	The optimal resolution is 2560 x 1600. If ON is selected, a message will appear on the screen after 30 seconds, notifying you that the resolution is not set to 2560 x 1600. Press "Left" or "Right" to select.

	Hot Key	When this function is activated; the brightness and contrast of the monitor can be adjusted without entering the OSD menu by using the front buttons. The “Left” or “Right” buttons adjust the brightness level. The “Down” or “Up” buttons adjust the contrast level.
	Factory Preset	Selecting Factory Preset allows you to reset all OSD control settings back to the factory settings. Highlighting the control to be reset and pressing the RESET button can reset individual settings.
Tag9	Grayscale Mode	This function changes the display image to monochrome. There are 3 types of settings. OFF: The Display Image is COLOR. MODE1: Input is R/G/B Color, but monitor uses only Green. The Display Image will become monochrome, because only green data passes the R/G/B LUT. MODE2: Input is R/G/B Color, but monitor changes the color space to YUV. The Display Image will become monochrome, because only Y data passes the R/G/B LUT.
	OSD Rotation	AUTO: The OSD rotates automatically when the monitor is rotated. OSD ROTATION is set to AUTO by default. MANUAL: To rotate the OSD, press the ROTATE OSD button when the OSD is not showing.
	Portrait Warning	When the monitor is used in the portrait position, the brightness value will be reduced to 300 cd/m ² . If the Portrait Warning is ON, a message will appear on the screen for 10 seconds.
	DDC/CI	DDC/CI ENABLE/DISABLE: Turns on or off the two way communication and control of the monitor.
	Screen Saver	Use the SCREEN SAVER to reduce the risk of image persistence. MOTION (Default OFF): Screen image moves periodically in 4 directions in order to reduce the risk of image retention. Timing for MOTION can be set so the screen image moves in intervals from every 10 to 900 seconds. Timing is set in 10-second increments. OPTION (Default REDUCED): There are two optional selections. REDUCED: Screen image is reduced to 95% size and is moved periodically in 4 directions. Screen may appear slightly less sharp than normal. The full image appears on the display. NOTE: Some input signals may not be supported by REDUCED. FULL: Screen image is set to FULL and is moved periodically in 4 directions. Screen image goes outside of the display area in the direction that it shifts so that a portion of the image may appear to be cut off. GAMMA (Default OFF): When OFF, the GAMMA selection that the display uses is the same as the GAMMA selection in Tag5 (page 20). When ON is selected, the GAMMA curve (except PROGRAMMABLE) becomes narrow, reducing the contrast and cutting down the risk of image retention. NOTE: SCREEN SAVER does not function when the TILE MATRIX function is enabled.
	Input Setting	Video Band Width (Analog input only): Reduce the visual “noise” level of the input signal. The video band width settings range from 0-7, with 0 having no correction and 7 having the most noise correction. Press “Left” or “Right” to select. Sync Threshold (Analog input only): Adjusts the slice level of a synchronization signal. Press “SELECT” to move the adjustment menu. Adjusts the sensitivity of the separate or composite input signals. Try this option if the FINE adjustment does not successfully eliminate the noise. SOG Threshold (Analog input only): Adjusts the sensitivity of the Sync On Green input signals. Adjusts the slice level when separating synchronization from sync On Green signal input. Press “Left” or “Right” to select. Clamp position: Operating your monitor at a non-standard timing may cause images to appear darker than normal or have color distortion. Use of the Clamp position control will adjust images to their normal state.

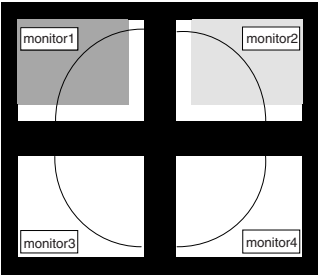
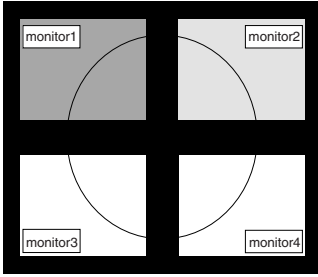
TagA	Tile Matrix	<p>The Tile Matrix feature allows one image to be displayed over multiple screens. This feature can be used with up to 25 monitors (5 vertical and 5 horizontal). Using Tile Matrix requires the PC output signal be sent through a distribution amplifier to each individual monitor.</p> <p>ENABLE: Select "ON", the monitor will expand the selected position.</p> <p>H MONITOR: Select the number of horizontal displays.</p> <p>V MONITOR: Select the number of vertical displays.</p> <p>MONITOR No: Select a position to expand the screen.</p> <p>TILE COMP: Works in tandem with Tile Matrix to compensate for the width of the tile bezels in order to accurately display the image.</p> <p>Tile Comp with 4 monitors (black area shows monitor frames):</p> <div style="display: flex; justify-content: space-around; align-items: center;">   </div> <p style="display: flex; justify-content: space-around;"> Tile Comp OFF Tile Comp ON </p>
TagB	Date & Time	<p>Sets the current date and time for internal clock. Date and Time must be set in order for the SCHEDULE function to work.</p> <p>Daylight Saving: For those timezones where Daylight Saving Time (Summertime) is observed.</p>
TagC	Schedule	<p>Programs the monitor's working schedule. Schedule the power on and power off with hour and a day of the week. Also sets the input port. This OSD can't remove except EXIT. Using the "SCHEDULE" function allows you to set up to seven different scheduled time intervals when the LCD Monitor will be activated.</p> <p>You can select the time the monitor turns on and turns off, the day of week the monitor is activated, and which input source the monitor will use for each scheduled activation period. A check mark in the box next to the number of the schedule indicates that the selected schedule is in effect.</p> <p>To select which schedule to set, use the up/down arrows to move the cursor vertically under the number (1 to 7) of the schedule.</p> <p>Use the "Down" or "Up" buttons to move the cursor horizontally within the particular schedule. The "SELECT" button is used to make a selection.</p> <p>If you create a schedule but do not want to use a power on time, select "--" in the "ON" time slot.</p> <p>If you do not want to use a power off time select "--" in the OFF time slot.</p> <p>If there is no input selected ("----" showing in the input spot) the input from the previous schedule will be used.</p> <p>The selection of EVERY DAY within a schedule takes priority over other schedules that are set up to operate weekly.</p> <p>Schedules are numbered 1-7. If two schedules are programmed for the same time, then the highest numbered schedule has priority. For example schedule #7 will take priority over schedule #5.</p> <p>When schedules are overlapping, scheduled Power ON time has priority over scheduled Power OFF time.</p> <p>When the "OFF TIMER" is set, the "SCHEDULE" function is disabled.</p> <p>Before powering off, a message will appear on the screen asking the user if they want to delay the turn off time by 60 minutes. Press any OSD button to delay the turn off time.</p>
TagD	Eco Mode Information	<p>Displays the estimated power saving information in watt-hours.</p>
TagE	Information	<p>Provides information about the current display resolution Technical data, including the preset timing currently being used and the horizontal and vertical frequencies is also displayed.</p> <p>Note: When connected to digital input, the OSD will show either DIGITAL(D) if a dual link signal is detected or DIGITAL(S) if a single link signal is detected.</p>

Self Calibration

Simply connect the external USB sensor, and the brightness, white tint and gamma levels are calibrated without the need of a computer. This feature works for displays requiring RGB calibration and graphical calibration.

Before proper self calibration can be performed, display should warm-up for a minimum 30 minutes. If the USB sensor is plugged in before the monitor is warmed up, a warning will appear on-screen (**Figure S.3**).

NOTE: Stand-alone calibration can only be performed using the X-Rite i1 Display Sensor. Refer to the KEY MAP (**Figure A**) when changing settings during the calibration.

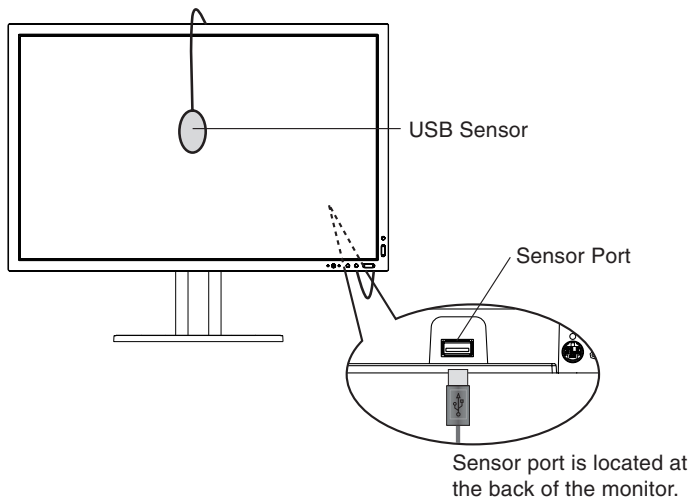

Figure S.1

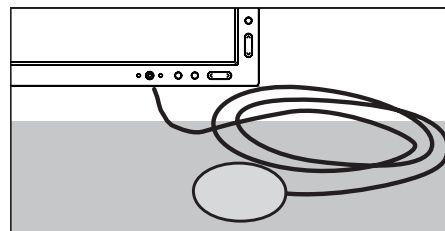

Figure S.2

KEY MAP	
UP/DOWN:	Changes from setting to setting
LEFT/RIGHT:	Changes the setting selection (ie...SELF or COPY)
SELECT:	Moves to the next step of calibration
EXIT:	Moves back one step of calibration

Figure A

1. Plug-in the USB sensor to the sensor port (**Figure S.1**).

NOTE: Sensor port can only be used for the sensor connection.

2. The calibration menu will open automatically and the sensor will begin to initialize. After initializing, the DARK-MEASUREMENT message is displayed. If the DARK-MEASUREMENT message is not displayed, please proceed to step 5.
3. Place the USB sensor face down on a non-reflective, opaque surface (i.e. desk or a mouse pad) to measure the black level (**Figure S.2**). Press "SELECT".
4. After the DARK-MEASUREMENT has succeeded (**Figure S.4**), press "SELECT" to continue. If DARK-MEASUREMENT fails (**Figure S.5**), restart the calibration procedure.

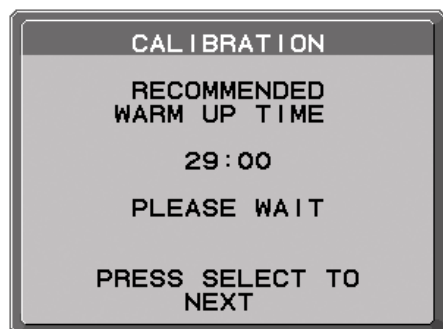

Figure S.3



Figure S.4



Figure S.5

5. Use "LEFT" or "RIGHT" to select SELF in the MODE selection (**Figure S.6**). Press "UP" or "DOWN" to move to the next selection.
Use "LEFT" or "RIGHT" to select Color mode in the Color Control System selection (**Figure S.6**). Press "UP" or "DOWN" to move the next selection.
6. Select the target GAMMA: NO CORRECTION, 2.2, OPTION, PROGRAMMABLE, CUSTOM, and SKIP (**Figure S.6**).

NOTE: If CUSTOM is selected, the Gamma Value can be manually changed in intervals of 0.1 at 0.5-4.0. If SKIP is selected, the GAMMA calibration is bypassed reducing calibration time.

7. The procedure will ask for the USB sensor to be placed on the center of the display panel (**Figure S.7**). Tilt the display panel approximately 5° backward and place the USB sensor in the center of the display panel (**Figure S.1**).

NOTE: Place the USB sensor flat against the LCD to avoid external light contamination. **DO NOT** press the calibrator against the display panel. Press “SELECT”.

8. Set the target LUMINANCE (cd/m²) (**Figure S.8**).

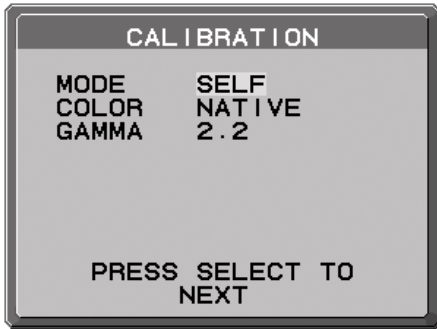

Figure S.6



Figure S.7

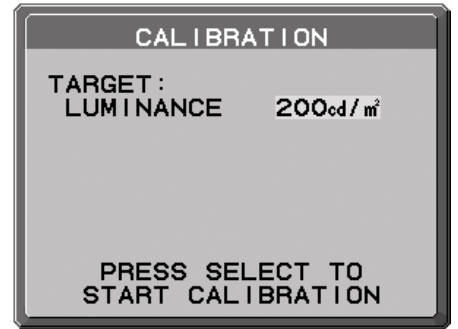

Figure S.8

9. Press “SELECT” to start the calibration. Stand-alone calibration may take several minutes depending on user settings.

10. After the CALIBRATION SUCCEEDED message appears (**Figure S.9**), press SELECT.

11. To end the calibration mode, press “EXIT”.



Figure S.9

White Point Matching/Copy Calibration

Calibration settings can be copied from one display to one or more additional displays. Using this feature reduces the variation between different displays allowing them to match each other more closely.

Before proper copy calibration can be performed, displays should warm-up for a minimum 30 minutes. If the sensor is plugged in before the minute warm-up, a warning will appear on-screen (**Figure C.4**).

NOTE: Stand-alone calibration can only be performed using the X-Rite i1 Display Sensor. Refer to the KEY MAP (**Figure A**) when changing settings during the calibration.

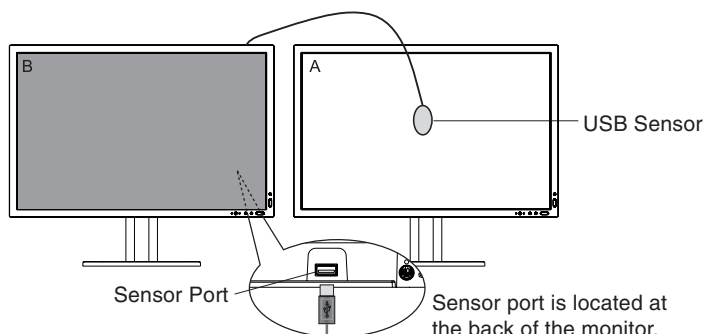

Figure C.1

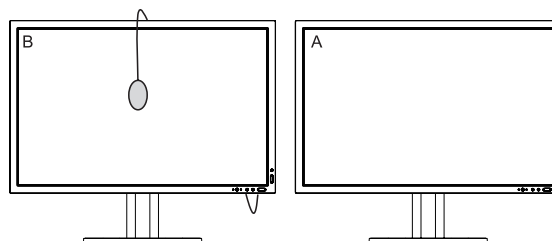

Figure C.2

Display A – SOURCE display of white point to copy.
Display B – TARGET display which performs a copy calibration.

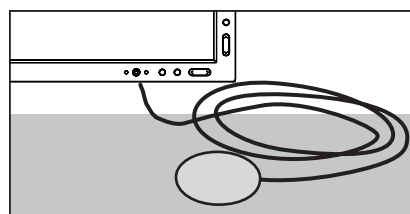

Figure C.3

KEY MAP	
UP/DOWN:	Changes from setting to setting
LEFT/RIGHT:	Changes the setting selection (ie...SELF or COPY)
SELECT:	Moves to the next step of calibration
EXIT:	Moves back one step of calibration

Figure A

1. Plug-in the USB sensor to the sensor port (**Figure C.1**).

NOTE: Sensor port can only be used for the sensor connection.

2. The calibration menu will open automatically and the USB sensor will begin to initialize. After initializing, the DARK-MEASUREMENT message is displayed. If the DARK-MEASUREMENT message is not displayed, please proceed to step 5.
3. Place the USB sensor face down on a non-reflective, opaque surface (i.e. desk or a mouse pad) to measure the black level (**Figure C.3**). Press "SELECT".
4. After the DARK-MEASUREMENT has succeeded (**Figure C.5**), press SELECT to continue. If dark-measurement fails (**Figure C.6**), restart calibration procedure at Step 1.

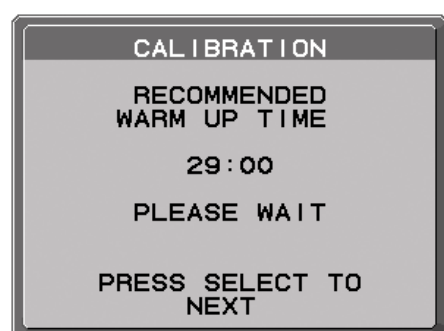

Figure C.4



Figure C.5



Figure C.6

5. Display A must display a white screen. Display the white screen using edit screen of word processor software and so on.

6. Using “LEFT” or “RIGHT” of Display B, select COPY in the MODE selection (**Figure C.7**). Select ON of OFF in the SELF selection. If ON selected, SELF Calibration execute with COPY Calibration.
7. Select the target GAMMA: NO CORRECTION, 2.2, OPTION, PROGRAMMABLE and CUSTOM. Please select the same target GAMMA as Display A.

NOTE: If CUSTOM is selected, the Gamma Value can be manually changed in intervals of 0.1 at 0.5-4.0.

8. The procedure will ask for the USB sensor to be placed on the center of the display panel (**Figure C.8**). Tilt the display panel approximately 5° backward and place the USB sensor in the center of the display panel (**Figure C.1**).

NOTE: Place the USB sensor flat against the display to avoid external light contamination. **Do not** press the calibrator against the display panel. Press “SELECT”.

9. Press SELECT on Display B to start reading the white point information of Display A.
10. After copying Display A information, the target luminance will be stored and displayed in the OSD of Display B. The target value is not adjustable (**Figure C.9**).

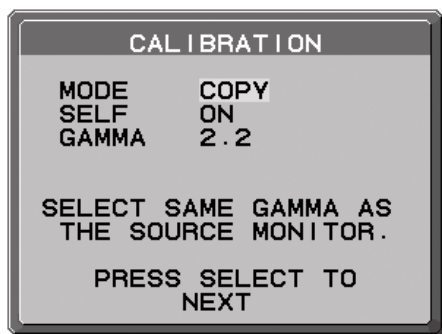

Figure C.7

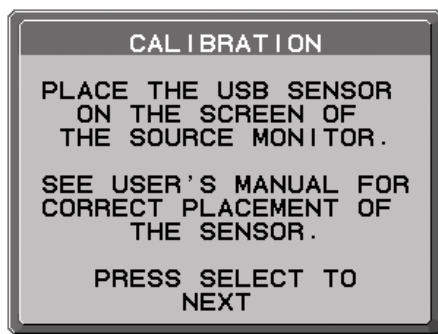

Figure C.8



Figure C.9

11. Remove USB sensor from source Display A and place in the center of Display B (**Figure C.2**).
12. Press SELECT to start the copy calibration. Copy calibration may take several minutes depending on user settings.
13. Once the calibration is successfully completed, the white points of Display A and Display B should match. After the CALIBRATION SUCCEEDED message appears (**Figure C.10**), press SELECT to continue into the Fine Tuning mode.
14. At the FINE TUNING MODE message (**Figure C.11**), press EXIT if the calibration is satisfactory. If the calibration is unsatisfactory, there are two options:
 - (A) Manually fine tune the white point using the “LEFT” and “RIGHT” keys.
 - (B) Restart the automatic copy calibration, press SELECT and return to Step 3.
15. To end the calibration mode, press “EXIT”.

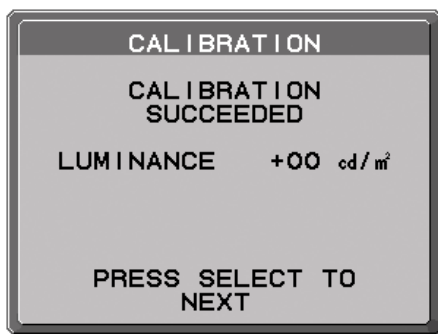

Figure C.10



Figure C.11

Using the Auto Brightness function

The brightness of the LCD screen can be set to increase or decrease depending on the amount of ambient light within the room. If the room is bright, the monitor becomes correspondingly bright. If the room is dim, then the monitor will dim accordingly. The purpose of this function is to make the viewing experience more comfortable to the eye in a variety of lighting conditions.

The Auto Brightness function is set to OFF by default.

NOTE: When “AUTO LUMINANCE” is ON, this function is disabled.

SETUP

Use the following procedure to select the Brightness Range that the monitor will use when the Auto Brightness function is activated.

1. Set the BRIGHT level. This is the brightness level that the monitor will go up to when the ambient light level is highest. Make sure the room is at its brightest when setting this level.

Select “1” in the AUTO BRIGHTNESS menu (**Figure 1**). Then use the front buttons to move the cursor up to the BRIGHTNESS setting. Choose the desired brightness level (**Figure 2**).

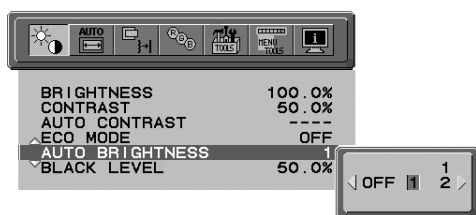

Figure 1

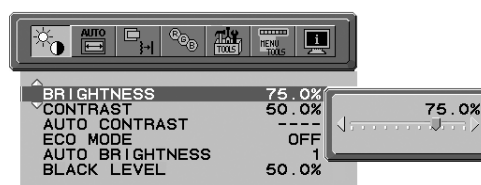

Figure 2

2. Set the DARK level. This is the level of brightness that the monitor will go down to when the ambient light level is low. Make sure the room is at its darkest when setting this level.

Then use the front buttons to move the cursor up to the BRIGHTNESS setting. Choose the desired brightness level (**Figure 3**).

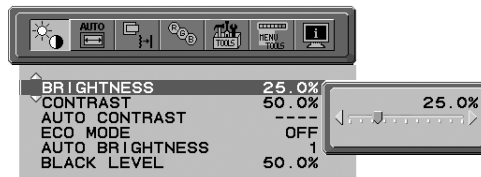

Figure 3

When the “Auto Brightness” function is enabled the Brightness level of the screen changes automatically according to the lighting conditions of the room (**Figure 4**).

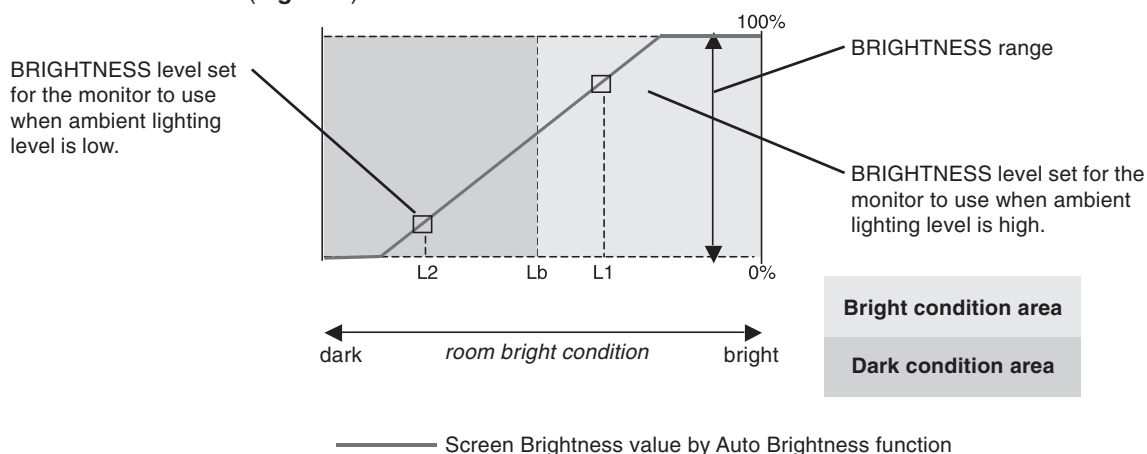

Figure 4

Lb: Border between bright and dim lighting conditions; set at factory
 L1: BRIGHTNESS level set for the monitor to use when ambient lighting level is high ($L1 > Lb$)
 L2 : BRIGHTNESS level set for the monitor to use when ambient lighting level is low ($L2 < Lb$)

L1 and L2 are the brightness levels set by the user to compensate for changes in ambient lighting.

TCO Development



Congratulations!

The display you have just purchased carries the TCO'03 Displays label. This means that your display is designed, manufactured and tested according to some of the strictest quality and environmental requirements in the world. This makes for a high performance product, designed with the user in focus that also minimizes the impact on our natural environment.

Some of the features of the TCO'03 Display requirements:

Ergonomics

- Good visual ergonomics and image quality in order to improve the working environment for the user and to reduce sight and strain problems. Important parameters are luminance, contrast, resolution, reflectance, color rendition and image stability.

Energy

- Energy-saving mode after a certain time – beneficial both for the user and the environment
- Electrical safety

Emissions

- Electromagnetic fields
- Noise emissions

Ecology

- The product must be prepared for recycling and the manufacturer must have a certified environmental management system such as EMAS or ISO 14 001
- Restrictions on:
 - chlorinated and brominated flame retardants and polymers
 - heavy metals such as cadmium, mercury and lead.

The requirements included in this label have been developed by TCO Development in co-operation with scientists, experts, users as well as manufacturers all over the world. Since the end of the 1980s TCO has been involved in influencing the development of IT equipment in a more user-friendly direction. Our labelling system started with displays in 1992 and is now requested by users and IT-manufacturers all over the world.

For more information, please visit
www.tcodevelopment.com

TCO Development



Congratulations!

The product you have just purchased carries the TCO'06 Media Displays label. This means that your display is designed and manufactured according to some of the strictest performance and environmental criteria in the world. The manufacturer of this display has selected it to be certified to TCO'06 Media Displays as a sign of usability, high performance and reduced impact on the natural environment.

Products certified to TCO'06 Media Displays are specifically designed for high quality reproduction of moving images. Features such as luminance, colour rendition and response time are important when watching TV or working with media, graphics, web design and other applications that demand outstanding moving images.*

Other features of TCO'06 Media Displays:

Ergonomics

- Good visual ergonomics and image quality in order to reduce vision and strain problems. Criteria for luminance, contrast, resolution, reflectance, colour rendition and response time.

Energy

- Energy saving mode – beneficial both for the user and the environment
- Electrical safety

Emissions

- Low electromagnetic fields surrounding the display

Ecology

- Product is designed for recycling. Manufacturer must have a certified environmental management system such as EMAS or ISO 14 001
- Restrictions on:
 - Chlorinated and brominated flame retardants and polymers
 - Hazardous heavy metals such as cadmium, mercury, hexavalent chromium and lead.

All TCO labelled products are verified and certified by TCO Development, an independent third party labelling organization. For over 20 years, TCO Development has been at the forefront of moving the design of IT equipment in a more user-friendly direction. Our criteria are developed in collaboration with an international group of researchers, experts, users and manufacturers. Since the program's inception, TCO labelled products have grown in popularity and are now requested by users and IT-manufacturers all over the world.

Full specifications and lists of certified products can be found on our homepage
www.tcodevelopment.com

* For a display used primarily for conventional work tasks such as word processing, we recommend a display certified to our office display series TCO'03 Displays or later version.

Manufacturer's Recycling and Energy Information

NEC DISPLAY SOLUTIONS is strongly committed to environmental protection and sees recycling as one of the company's top priorities in trying to minimize the burden placed on the environment. We are engaged in developing environmentally-friendly products, and always strive to help define and comply with the latest independent standards from agencies such as ISO (International Organisation for Standardization) and TCO (Swedish Trades Union).

Disposing of your old NEC product

The aim of recycling is to gain an environmental benefit by means of re-use, upgrading, reconditioning or reclamation of material. Dedicated recycling sites ensure that environmentally harmful components are properly handled and securely disposed. To ensure the best recycling of our products, **NEC DISPLAY SOLUTIONS offers a variety of recycling procedures** and gives advice on how to handle the product in an environmentally sensitive way, once it has reached the end of its life.

All required information concerning the disposal of the product and country-specific information on recycling facilities can be found on our following websites:

<http://www.nec-display-solutions.com/greencompany/> (in Europe),

<http://www.nec-display.com> (in Japan) or

<http://www.necdisplay.com> (in USA).

Energy Saving

This monitor features an advanced energy saving capability. When a VESA Display Power Management Signalling (DPMS) Standard signal is sent to the monitor, the Energy Saving mode is activated. The monitor enters a single Energy Saving mode.

Mode	Power consumption	LED color
Normal Operation (for TCO testing)	Approx. 81W	Green or Blue
Normal Operation (with option)	Approx. 157W	Green or Blue
Energy Saving Mode	Less than 1.3W	Amber
Off Mode	Less than 1W	Unlit

WEEE Mark (European Directive 2002/96/EC)



Within the European Union

EU-wide legislation, as implemented in each Member State, requires that waste electrical and electronic products carrying the mark (left) must be disposed of separately from normal household waste. This includes monitors and electrical accessories, such as signal cables or power cords. When you need to dispose of your NEC display products, please follow the guidance of your local authority, or ask the shop where you purchased the product, or if applicable, follow any agreements made between yourself and NEC.

The mark on electrical and electronic products only applies to the current European Union Member States.

Outside the European Union

If you wish to dispose of used electrical and electronic products outside the European Union, please contact your local authority so as to comply with the correct disposal method.