

PRELIMINARY

ID Top

Firmware version 14.35 and newer

Manual OVR-line

Contents

1	Introduction	4
	RFID Regions	4
	CE WEEE	5
	Battery disposal	5
2	Product overview	6
	Box contents	6
	Components	6
	Dimensions	7
	Connections	8
3	Preparing the installation	10
	Defining the system	10
	Detection distance, aisle width and label-free zone	10
	RFID installation requirements	12
	Orientation of products	13
	Device Management	15
4	Executing the installation	16
	Removing the cover	16
	Physical installation - on the ceiling	16
	Physical installation - on the wall	18
	Physical installation - with VESA compatible mount	18
	Installing cabling and filters	19
	Status LEDs	19
5	Configuring the installation	23
	Driver installation	23
	Recent browser	23
	Connecting a laptop to the Renos unit	24
	Entering the configuration wizard	24
	Authentication	24
	Getting help in the wizard	25
	Firmware version and System ID	25
	Factory reset	25
	Firmware change	26
6	Integrating the installation with other systems	28
	Software integration with API's	28
7	Servicing the installation	29
	Nedap Device Management	29
	SNMP	29
8	Troubleshooting	30

Physical installation	30
Configuration	31
9 Regulatory information	32
FCC and IC Compliance statement	32
FCC and IC Radiation Exposure Statement	32
FCC Information to the user	32
10 About Nedap	34
About	34
Contact	34

1 Introduction

The Nedap OVR-line products are wall- or ceiling-mounted integrated readers equipped with Ultra High Frequency (UHF) RFID. The readers are specifically designed for in-store retail applications, such as Electronic Article Surveillance (EAS), stock room to sales floor transition and goods receiving.

Knowledge Base articles

This manual provides an overview of the products, the installation and configuration. To obtain more details on various topics or background information, several Knowledge Base articles are available, and are referred to in this manual. You can find the Knowledge Base articles on the Nedap Retail portal.

This manual covers the following products:

Article number	Article name	Technologies	Model name	FCC ID	IC
9982191	ASSY OV37R RFID R1 GREY	UHF RFID			
9982205	ASSY OV37R RFID R2 GREY	UHF RFID	ASSY FLR RF	CGDOVRRFID	1444A-OVRRFID
9982213	ASSY OV37R RFID R3 GREY	UHF RFID			

 This manual is for Nedap Retail certified service engineers only.

This product contains no user serviceable parts. Nedap Retail equipment should be serviced only by authorized Nedap Retail service engineers. They will ensure that service procedures and replacement parts used will not affect performance.

RFID Regions

Region 1: Europe (ETSI EN 302 208), Armenia, Azerbaijan, Hong Kong, India, Jordan, Oman, Russia, Saudi Arabia, South Africa, Tunisia and United Arab Emirates

Region 2: United States (FCC Part 15.247), Australia, Brazil, Argentina, Canada, Chile, Colombia, Costa Rica, Dominican Republic, Israel, Mexico, New Zealand, Panama, Peru, Taiwan, Uruguay and Venezuela

Region 3: People's republic of China, Singapore, Hong Kong, Japan, Korea, Thailand and Vietnam

CE WEEE

This European Standard specifies a marking

- of electrical and electronic equipment in accordance with Article 11(2) of Directive 2002/96/EC (WEEE); This is in addition to the marking requirement in Article 10(3) of this Directive which requires producers to mark electrical and electronic equipment put on the market after 13 August 2005 with a 'crossed-out wheeled bin' symbol.
- that applies to electrical and electronic equipment falling under Annex IA of Directive 2002/96/EC, provided the equipment concerned is not part of another type of equipment that does not fall within the scope of this Directive. Annex IB of Directive 2002/96/EC contains an indicative list of the products, which fall under the categories set out in Annex IA of this Directive;
- that serves to clearly identify the producer of the equipment and that the equipment has been put on the market after 13 August 2005.



Battery disposal

This product contains a non-rechargeable lithium battery. Replace only with the same or equivalent type recommended by the manufacturer (Panasonic CR2032 lithium button cell). At the end of its useful life, under various state and local laws, it may be illegal to dispose of this battery into the municipal waste stream. Check with your local solid waste officials for details in your area for recycling options or proper disposal.



Caution

Risk of explosion if battery is replaced by an incorrect type.
Dispose of used batteries according to the instructions.

2 Product overview

There is only one variation within the OVR-line, one that supports UHF RFID technology.

 In this document the following abbreviation will be used from here onwards:

- 'RFID technology' is an abbreviation for UHF RFID technology.

Box contents

Article number	Article name	Box contents
9982191	ASSY OV37R RFID R1 GREY	<ul style="list-style-type: none"> • OV37 Integrated Reader with Renos, RFID reader and RFID antenna • Installation set
9982205	ASSY OV37R RFID R2 GREY	<ul style="list-style-type: none"> • OV37 Integrated Reader with Renos, RFID reader and RFID antenna • Installation set
9982213	ASSY OV37R RFID R3 GREY	<ul style="list-style-type: none"> • OV37 Integrated Reader with Renos, RFID reader and RFID antenna • Installation set

Components

The OVR-line of products are based on the Renos platform. The Renos platform is developed by Nedap Retail specifically for retail applications. The OVR-line of products has several serviceable parts. These are explained in the table and highlighted in the schematic drawings.

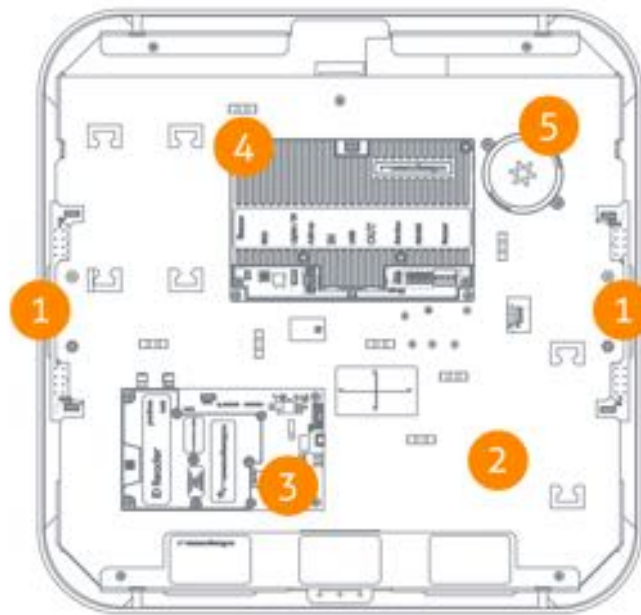

Number Component Description

1	Lights	The red LED lights can be used for user feedback or alarms.
2	RFID antenna	The RFID antenna.
3	RFID reader	The RFID reader takes care of reading RFID labels. It is connected to the Renos unit, and to the RFID antennas.
4	Renos unit	The Renos unit is the main processing unit of an OVR product. It takes care of powering the system, data communication between units and with the outside world.
5	Buzzer	The buzzer can be used for user feedback or alarms.

Dimensions

The dimensions of the gates can be found in the drawings below.

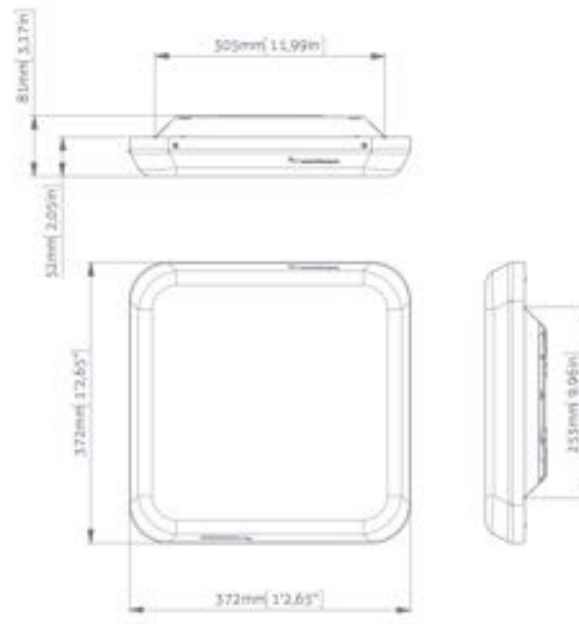

The next picture shows the mounting plate, which can be used as a wall or ceiling mount, but also connected to a VESA mount.

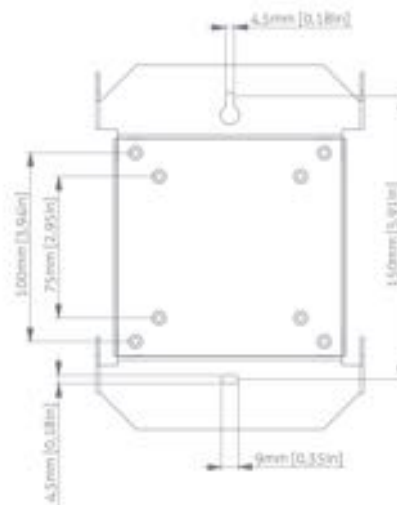

Connections

In the next picture a Renos unit is displayed, with a description of all its connectors and what they are used for.

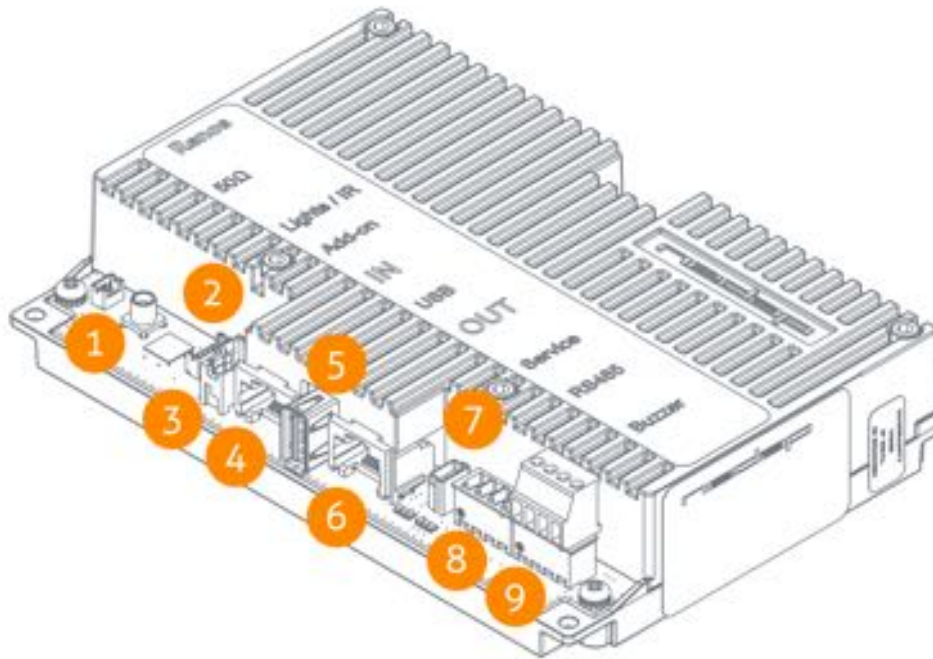

Number	Connector	Usage
1	50 ohm	Not used in the OVR-line.
2	Infrared beams	Connect to the lights.
3	Add-on	Provide power and synchronization to add-ons, like the RFID reader.
4	Network IN	Connected to the Network OUT of a previous Renos unit or a Power Inserter.
5	USB	Connect accessories to Renos, like the RFID Reader.
6	Network OUT	Connected to the Network IN of a previous unit or a Power Inserter. Can also be left unconnected or connected to the customer network.
7	Mini USB service port	Connect your laptop to configure the Renos system.
8	RS485 connector	Not used in the OVR-line.
9	Buzzer connector	Connect to the included buzzer.

The LED indicators on the Renos unit will be discussed later in this manual.

3 Preparing the installation

When preparing an installation with OVR-line products, there are a few things that should be taken into account:

- Placement in relation to the environment (walls and other objects)
- Orientation of the product

If the placement of the products is decided, the next step is to evaluate cabling and placement of Power Inserters.

Defining the system

When a store requires readers to be placed at several locations, there needs to be a decision on how to combine these readers into one or multiple systems. The following needs to be taken into account:

1. **A different role is a different system.** It is not possible to combine readers for Electronic Article Surveillance (EAS) with readers for stock room to sales floor in one system. Both roles need different systems with their own Power Inserter and customer network connection.
2. **Within the EAS role, create as large systems as possible.** To minimize interference between readers, the Renos platform has a built-in synchronization mechanism for RFID technology. For this synchronisation mechanism to work, the readers need to be connected in one system.
3. **However, the maximum cable length requirements needs to be satisfied.** If it is not possible to put all the reader within a role in one system due to the maximum cable length requirements, you can split the readers into two or more systems.

Stock room to sales floor and goods receiving

For the stock room to sales floor and goods receiving roles: when there is a different door or entrance, build a separate system.

Detection distance, aisle width and label-free zone

The first decision to be made is how many readers you need, and where to place them. This depends on the aisle width and detection height of the system. There is no fixed answer to this question, it depends on many factors, like customer expectation, quality of the tags, the environment, etc.

The recommendations below are based on the Nedap RFID hard tag (for RFID).

We recommend to mount the reader between 2.5 m and 3.5 m (8.2 ft. to 11.5 ft.) height.

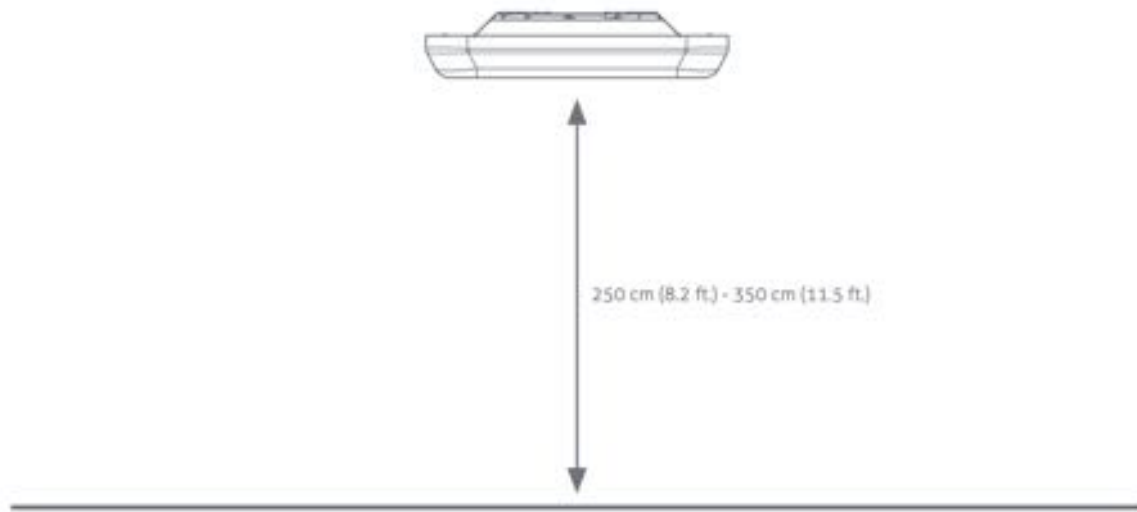

We recommend to place the readers at 2.5 m (8.2 ft.) aisle width.



i Please note that only the recommended 'detection distance' or 'aisle width' is specified. Depending on the tag used and the environment the gates are placed in, sometimes larger values are obtainable. It is advised to test this, before using it in a store.

We recommend to have a label-free zone of more than 150 cm (4.9 ft.) from the center of the antenna.

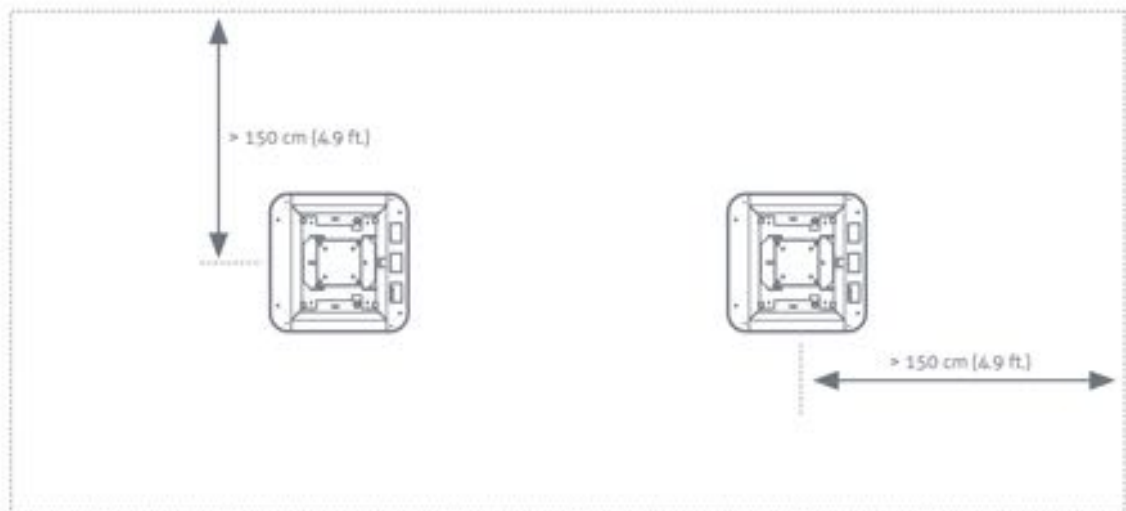

RFID installation requirements

When RFID technology is used, there are different installation requirements to consider than with RF technology. Since the RFID field is much less strict defined than with RF technology, there is a larger area where tags could be detected. In contrary to RF, RFID is much less sensitive to coupling or interference issues.

Automatic tag muting

The RFID reader has a maximum read throughput of around 200 tag reads per second. This throughput is used to monitor the status of the tags continuously. When many tags are placed close to or in the label-free zone, it might be that the reader is 'too busy' with those tags, compared to other tags. This will impact the system performance. If this happens, the reader will mute some tags, to have time remaining for other tags. This feature is called *automatic tag muting*. It might therefore be that some tags in the neighborhood of the system are muted, and will not cause an alarm when moved along the reader.

Metallic surfaces

As the RFID field is reflected by metallic surfaces, this might confuse the Dynamic Beam Steering algorithms and influence (change or enlarge) the detection field. That is why we advise to avoid large metallic surfaces (larger than an A3/Tabloid sheet of paper) in the neighborhood of readers.

Power Inserter

When the installation location of the products is clear, the location of Power Inserters need to be defined. There is a maximum number of Renos units that can be connected to one Power Inserter, but that depends on which technologies are used and the number of add-ons that are in use.

Number of Renos units per Power Inserter

230 V	115 V
6	5

Of course, it is also possible to put less Renos units on a Power Inserter.

Power Inserters

Please note that you can only use a Nedap Power Inserter (Power-over-Ethernet) to power Renos systems. It is not possible to use generic Power-over-Ethernet switches or stand-alone inserters.

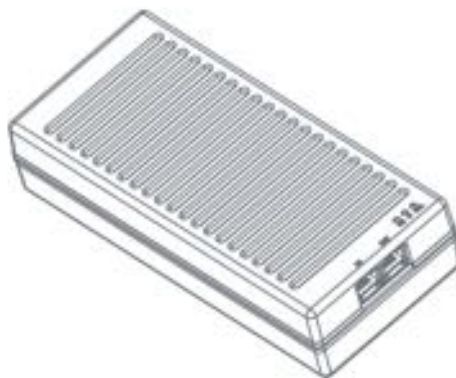

- It is recommended that the Power Inserter is connected to an always-on power socket. This allows continuous monitoring of the system, and remote firmware update during the night.

Orientation of products

Due to the orientation-sensitivity of the RFID antennas, the readers all need to be oriented in the same way.

Inside the reader there is a sticker indicating which orientation to mount the system, and which side the shop floor should be in relation to the store exit. The location of the sticker is indicated in the next picture.



⊖ If this procedure is not executed correctly, the RFID technology will not work.

Cabling

As the basis placement and orientation is clear, the cabling needs to be put into place. Depending on the technologies that are used, different cabling types are recommend. The OVR-line uses a daisy chain topology, which means that all devices are connected as a chain: a cable from a Power Inserter OUT to a Renos unit IN, from that Renos unit OUT to the next Renos unit IN, etc. The units are connected with an Ethernet cable only.

The maximum data communication length for an Ethernet cable is 100 meter (328 ft.). Therefore we recommend the following maximum distances:

- The maximum cable length in between two Renos units is 100 meter (328 ft.) - even if there is a Power Inserter in between.
- The maximum cable length from the Power Inserter to the last Renos unit powered by that Power Inserter is also 100 meter (328 ft.)

✔ When the cable lengths allow for it, we recommend to place the Power Inserter in the switch room. In this way the customer only has to arrange an Ethernet outlet near the installation, and no power sockets are needed. This could reduce the cost for installations significantly.

When a connection to the customer network is to be made for local access or Device Management, this connection can be made from:

- The customer network to the IN port of the Power Inserter.
- The customer network to the OUT port of the last Renos unit in the chain.

The exact location needs to be configured during the configuration wizard.



Ethernet cable type

Please use Ethernet Cat. 5 cable or better with all 8 pairs connected.



Cable number Type of cable

Cable number	Type of cable
1	Ethernet cable

Device Management

All the Renos-based products can be connected to the Nedap Device Management Service. This service provides:

- **Monitoring.** Critical system parameters are monitored 24/7. As soon as something is wrong with the system, an alert is generated to the supporting partner.
- **Remote log-in.** Via the Device Management portal it is possible for an authorized Nedap-certified engineer to access the user interface of the system to make changes to the configuration or access system logs.
- **Firmware update.** It is possible to install new firmware releases remotely.

To use Device Management, please make sure that the following firewall ports are opened before installation:

- TCP port 443 outgoing to *.nedapretail.com

This can be verified by connecting your laptop to the customer network, open your browser and navigate to <https://api.nedapretail.com>. You should see a special page there.

It is also possible to do this via an HTTPS proxy, however, the remote log-in feature is not available then.

For more details, please see the Knowledge Base article on Device Management.

-  If Device Management is available at a certain site, it is possible to pre-configure a system, such that the field engineer will have an easier job. For more information, please refer to the Knowledge Base article on Pre-configuration.

4 Executing the installation

When all the preparations are taken into account, the installation can take place. This chapter will explain the physical installation, placing the cabling and checking the status of the system.

The reader can be mounted both on the ceiling, on the wall or with a VESA-compatible mount.

Removing the cover

The cover can be removed by:

1. Gently pushing a screwdriver at the indicated location.
2. Hold the screwdriver in place, and slide the cover towards the indicated direction. It will come off the unit.



Physical installation - on the ceiling

The included steel cabling set can be used to mount the unit on the ceiling. The steel cabling set should be mounted in a 'V' shape (as indicated in the picture below), such that the unit will not easily swing due to wind or heaters. When mounted in a 'A' shape this will easily happen.

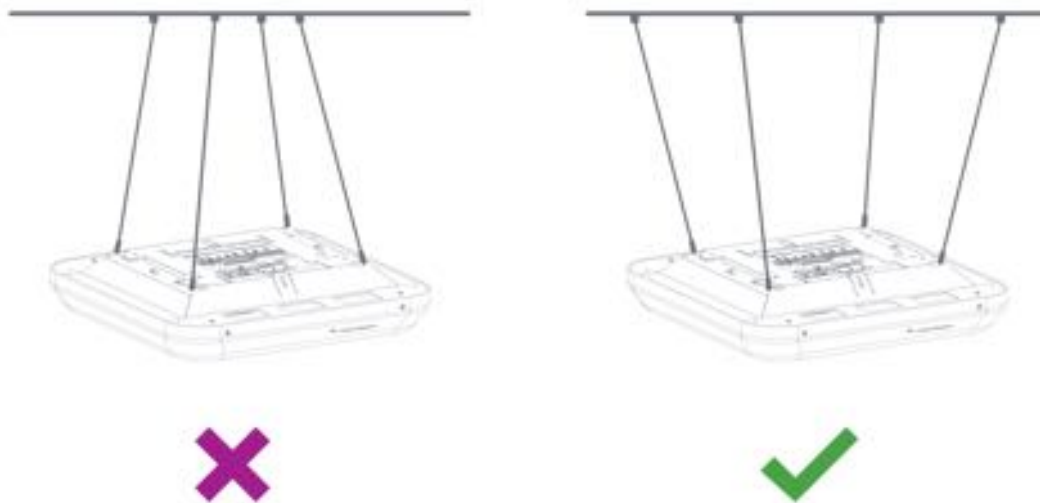

Follow the next steps when mounting the unit:

- Mark the drilling holes on the ceiling.
 - Drill the holes and install a plug.
1. Mount the base unit (with the threaded rod) with a 4x40 screw.
 2. Slide the steel cable through the bus unit (make sure the round sphere is on top).
Screw it on the base unit.
 3. Slide the adjustable hook over the steel cable.
If you want to release it, press the indicated button on the hook.



i When the installation is completed, place the mounting plate back in the unit. The mounting plate doubles as dust protection for the inner components of the unit.

Physical installation - on the wall

The unit can be mounted on the wall using the include mounting bracket.

- Attach the mounting plate with two screws to the wall.
- Install all cabling to the reader.
- Slide the reader over the mounting plate as indicated in the picture.

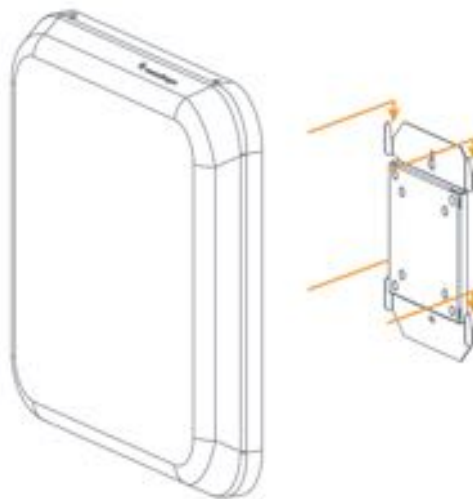

✔ The mini USB service port is not accessible when the reader is mounted in this way. Configure the unit before sliding it over the mounting plate.

Physical installation - with VESA compatible mount

The mounting plate has the following VESA compatible mounts:

Standard	Pattern size	Screw thread	Screw length excl. bracket
MIS-D 75mm	75 x 75 mm (2.95 x 2.95 in.)	M4	7.4 mm (291 mil)
MIS-D	100 x 100 mm (3.93 x 3.93 in.)	M4	7.4 mm (291 mil)

The installation process is as follows:

- Mount the VESA mount to the mounting plate.
- Install all cabling to the reader.

- Slide the reader over the mounting plate as indicated in the picture.

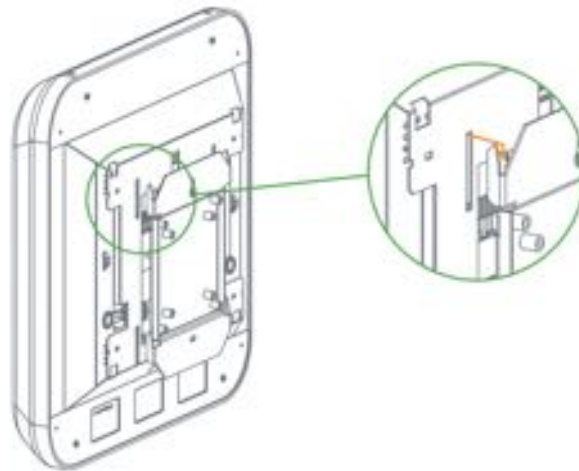

Installing cabling and filters

During the preparation phase, the exact cabling required was already determined. Now these cables can be placed.

Ethernet cables

Connect the Ethernet cable from the OUT port with the IN port of the next Renos unit

First, in all aisles connect the Ethernet OUT port with the IN port of the next Renos unit, always following the directions of the arrows in the cabling indicated by the image below.

 Please make sure that every Ethernet cable created is tested for all 4 pairs (8 wires) with an Ethernet cable tester. This to make sure that there are no errors appearing down the road.

Status LEDs

The electronics inside the unit has several status LEDs that can be used to discover the status of each part of the electronics.

Renos unit

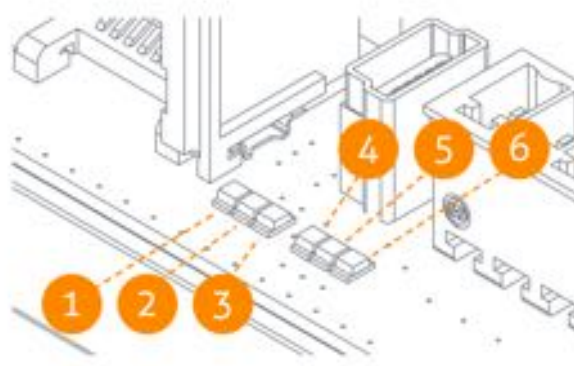

Led	Color	Status	Explanation
1	Green	On	There is a Renos unit connected to the OUT port of this unit
		Off	There is no Renos unit connected to the OUT port of this unit
2	Blue	Blinking	There is no device connected to the OUT port of this unit
		On	There is a Power Inserter connected to the OUT port of this unit
3	Red	On	There is an issue with the power supply at the OUT port of this unit (too little current drawn)
		Blinking	There is an issue with the power supply at the OUT port of this unit (too much current drawn)
		Off	There is no issue with the power supply at the OUT port of this unit
4	Yellow	Blinking	The operating system on the Renos unit is running
		Off	The operating system on the Renos unit is not running
5	Green	Blinking	The storage flash on the Renos unit is accessed
		Off	The storage flash on the Renos unit is not accessed
6	Green	On	The firmware on the Renos unit is running
		Off	The firmware on the Renos unit is not (yet) running

Please refer to the Troubleshooting chapter later in this manual to resolve erroneous conditions.

Firmware error

If the Renos unit has a firmware error, the rightmost three LEDs (4, 5 and 6) will remain off when the unit is powered. This can be solved by using a 'Local - single unit' firmware update, as is described later on in this manual.

RFID reader

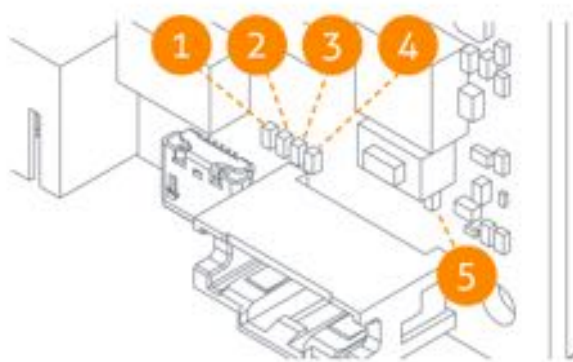

Led	Color	Status	Explanation
		On	The RFID Reader is connected to the Renos firmware
1	Blue	Blinking	The RFID Reader has received a command from the Renos firmware
		Off	The RFID reader is not connected to the Renos firmware
2	Orange	Blinking slow	The firmware on the RFID Reader is running
		Off	The firmware on the RFID reader is not running
3	Red	On	There is an error with the RFID output
		Off	There is no error with the RFID output
4	Green	On	The RFID output is active
		Blinking	The reader is reading RFID labels
		Off	The RFID output is not active
5	Green	On	The RFID reader is powered by the Renos unit

Led	Color	Status	Explanation
		Off	The RFID reader is not powered by the Renos unit

ⓘ Status of LEDs before configuration

When the system is not configured yet, the RFID reader will not be active. This means that only the 'firmware running' orange LED is blinking.

5 Configuring the installation

To complete the configuration, the following tools are required.

- Mini-USB cable.
- Laptop with installed driver (if necessary) and recent browser.

Driver installation

To configure a Renos-based system, sometimes a driver needs to be installed. Please check the table below whether you need to install a driver, based on your operating system.

Operating system	Driver
Windows XP, Vista or 7	Download from portal
Windows 8	No need to install driver
Mac OS X	No need to install driver
Linux	No need to install driver

Once you have installed the driver, check if it works by plugging-in a Renos unit.

Recent browser

To configure the system, an HTML5 compatible browser should be installed on your laptop. The following browsers (or higher) are officially supported:

- Google Chrome
- Mozilla Firefox 6 (or higher)
- Apple Safari 6 (or higher)
- Microsoft Internet Explorer 9 (or higher)

If you don't have one of these browsers installed on your laptop, please install them now.

Connecting a laptop to the Renos unit

You can connect your laptop via a Mini-USB cable to the service port on the Renos unit. You can choose any Renos unit in the system.

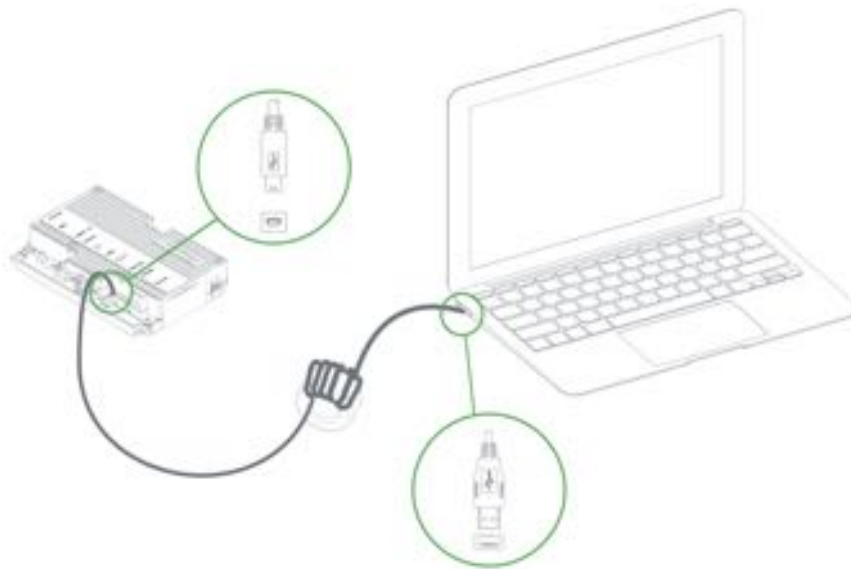

i It is advisable to use a long USB cable. This is more comfortable as you can find a good place to put your laptop (instead of on top of stairs, or on the floor next to the antenna). Besides, some laptops cause interference on the RF technology, so it is better to place them further away.

✓ We advise to use a ferrite ringcore filter around the mini USB cable that is used to configure Renos. These can be ordered as spare part with Nedap. Please refer to the Nedap Retail Portal for more information.

Entering the configuration wizard

You can enter the configuration wizard by opening your browser, and navigating to:

<http://192.168.133.1>

Authentication

During the configuration, the user is required to authenticate himself. How this is done, is dependent on the Device Management availability.

- The system is connected to Device Management: you can directly enter your Nedap Retail username and password.
- The system is not connected to Device Management, and you don't have a Nedap Retail authentication software or hardware dongle: choose one of the following steps:
 - If your laptop is able to connect to Device Management via a 3G dongle or Wi-Fi, you can use this option to enter your username and password.
 - If that is not available, you can use your smartphone.
 - If your smartphone has no internet access, you can call our support to get an authentication code.

Please contact support for more details on how to obtain a Nedap Retail username and password.

Getting help in the wizard

If something is not clear, each page has a question mark button in the top right corner. You can click this to get more information on what is expected to do on a certain page.

Firmware version and System ID

When you ask for support for a specific system, the support engineer will always ask you for the firmware version and the system ID. The firmware version is displayed in the right top of the configuration wizard. If you click the firmware version, a pop-up will appear that shows the System ID.

Factory reset

To execute a factory reset on a single Renos unit, the following steps need to be executed:

1. Turn off the system by removing the power cable of the Power Inserter.
2. Connect a Mini-USB cable from the USB service port to the USB port on the Renos unit.
3. Reconnect the power cable to the Power Inserter.
4. The LED that usually indicates that the firmware is running (the green LED on the right) will show the following behaviour:
 - a. Blink couple of times
 - b. Stay on
 - c. Blink couple of times

When this is completed, wait one minute before proceeding.

5. Turn off the power.
6. Remove the USB cable.
7. Turn on the power.

 **Configuration is lost**

Please note that when doing a factory reset, all settings and configuration of the unit are lost. The firmware version does not change.

Firmware change

There are three ways to change the firmware version on a Renos-based system:

1. Device Management update. The update can be executed via the Device Management service.
2. Local - single unit flash. The update can be executed by inserting a USB stick with the right firmware into the USB port.
3. Local - complete system flash. The update can be executed during the configuration wizard with files on your laptop.

 If the system is integrated with a 3rd party system, please confirm the firmware version with that 3rd party before installing it.

Device Management update

To update the firmware via Device Management, please make sure the system is configured, delivered and connected to the Device Management service. Then, navigate to the Device Management website and use the functionality there to initiate the firmware update.

Local - single unit flash

Download the correct firmware image file from the Nedap Retail portal. Extract this file to a USB stick. Turn off the power of the system. Insert the USB stick in the USB port of a Renos unit. Power the system. Wait until LEDs 4, 5 and 6 are off again. This can take around ten minutes. Then turn off the power again, remove the USB stick and turn on the power.

Configuration is lost

Please note that when using 'local - single unit flash' firmware change, all settings and configuration of the unit are lost.

It's only possible to execute this on-site and not remotely, as the system needs to be re-configured before it is usable again.

Local - complete system flash

Download the correct firmware image file from the Nedap Retail portal. Enter the configuration wizard and accept all Renos units in the system that should be updated. Press the Advanced button and follow the steps to change the firmware. One of these steps is to upload the firmware image file.

Configuration is lost

Please note that when using 'local - complete system flash' firmware change, all settings and configuration of the system are lost.

It's only possible to execute this on-site and not remotely, as the system needs to be re-configured before it is usable again.

6 Integrating the installation with other systems

It is highly recommended to integrate the FLR line product into other solutions in use at the end customer.

Software integration with API's

The Renos platform offers several API endpoints that deliver events. Those events include:

- RFID reads
- RFID movements
- RF alarms
- RFID alarms
- Infrared beam sensor events

For more information please refer to the Software integration page on the Nedap Retail portal with documentation and examples.

7 Servicing the installation

When the installation has been completed and delivered, it is possible to service the installation via Nedap Device Management. Besides, we provide monitoring options locally via SNMP.

Nedap Device Management

Via Nedap Device Management the following features are available, when the system is connected to Nedap Device Management.

- System monitoring via some key metrics. The following key metrics are available:
 - Whether RFID is operating successfully
 - Whether all Renos units are active
 - Whether all infrared beam sensors are operating without blocked aisles
 - Whether there are suspected false EAS alarms (RFID only)
 - Whether the buzzers and lights are muted
- Firmware update. As described before, the firmware of the Renos system can be updated via Device Management.
- Remote log-in. It is possible to access the configuration wizard remotely via Device Management.

These features are available via a web interface and an API, which can be used to integrate Nedap Device Management into 3rd party solutions. For more information, please contact support.

SNMP

To allow for local monitoring of Renos systems, and integration into existing IT infrastructure we support Simple Network Management Protocol (SNMP). The following variables are available on the Renos platform:

- One or more Renos units are not reachable
- The status of the RFID subsystem
- One or more infrared beam sensors are blocked
- The system is connected to Device Management

Repos systems use SNMP version 2c, community public. The MIB file is available on the Renos system itself via the URL [http://\(ip address of the system\)/snmp](http://(ip address of the system)/snmp) (for example, that is <http://192.168.133.1/snmp> when connected to the USB service port).

8 Troubleshooting

If the system is not working correctly, please check the troubleshooting options below. If it is not possible to solve your issue, you can find support options in the next chapter.

Physical installation

Symptom	Cause	Solution
The red LED (3) on a Renos unit is on.	The current drawn out of the OUT port of the Renos unit is too low. The cabling at the OUT port of the Renos unit does not satisfy the maximum length requirements.	Verify whether the cabling length in the system satisfies the requirements posed earlier in this document.
	The current drawn out of the OUT port of the Renos unit is too low. The connectors of the Ethernet cable at the OUT port of the Renos unit are not mated properly.	Check the Ethernet cabling at the OUT port of the Renos unit with a Ethernet cable tester.
The red LED (3) on a Renos unit is blinking.	The current drawn out of the OUT port of the Renos unit is too high. Too much Renos unit and add-ons connected to one Power Inserter.	Verify the number of Renos units and add-ons connected to the Power Inserters with the table earlier in this document.
	The current drawn out of the OUT port of the Renos unit is too high. There is a short circuit in the cabling leaving the OUT port of this Renos unit.	Check the Ethernet cabling at the OUT port of the Renos unit with an Ethernet cable tester.
The green LED (1) on a Renos unit is off, but there is a unit behind this unit.	There is an issue in the cabling between those unit, such that the following unit is not recognized.	Check Ethernet cabling with an Ethernet cable tester.
The red LED (3) on the RFID reader is on.	There is an issue with the RFID reader trying to start reading. This might be cause by an erroneous antenna or a cabling error.	Log in to the Renos configuration interface to see the exact error.

Configuration

Symptom	Cause	Solution
	Renos unit has not started yet	Verify the green "firmware running" LED on the Renos unit (6). If this LED is not on, verify the system has power or wait five minutes and try again.
It is not possible to access the configuration web interface.	Mini USB cable not attached to Renos unit and laptop	Attach cable to Renos unit and laptop.
	Driver not installed	On Windows 7 and older you manually need to install a driver to support Renos.
I have put a system together, but I only see a part of all units during the hardware discovery.	During configuration, the WAN access port will be 'closed' for internal network traffic. If you combine two systems later on, this needs to be re-openend.	Do a factory reset on the unit that was previously used as WAN entry point. If that doesn't work, do a factory reset on all units.
	There is a cabling error.	Please check all Ethernet cabling with an Ethernet cable tester.
	Not all Power Inserters are powered, or some Renos units are not fully started.	Verify the green "firmware running" LED on the Renos unit (6). If this LED is not on, verify the system has power or wait five minutes and try again.
There is a firmware failure, indicated by the fact that all three LEDs 4, 5 and 6 are off on the Renos unit.	Something might has gone wrong with a firmware update.	Use the 'local - single' unit firmning update mechanism to restore the unit.
I have configured RFID, but it detects labels outside the aisle, not inside.	Gates are positioned the wrong way.	Check the "Orientation of products" section in the manual and correct the orientation of the gates.

9 Regulatory information

FCC and IC Compliance statement

This device complies with part 15 of the FCC Rules and to RSS210 of Industry Canada. Operation is subject to the following two conditions:

- (1) this device may not cause harmful interference, and
- (2) this device must accept any interference received, including interference that may cause undesired operation.

Changes or modifications not expressly approved by the party responsible for compliance could void the user's authority to operate the equipment.

Cet appareil se conforme aux normes RSS 210 exemptés de license du Industry Canada. L'opération est soumis aux deux conditions suivantes:

- (1) cet appareil ne doit causer aucune interférence, et
- (2) cet appareil doit accepter n'importe quelle interférence, y inclus interférence qui peut causer une opération non pas voulu de cet appareil.

Les changements ou modifications n'ayant pas été expressément approuvés par la partie responsable de la conformité peuvent faire perdre à l'utilisateur l'autorisation de faire fonctionner le matériel.

FCC and IC Radiation Exposure Statement

This equipment complies with FCC and Canadian radiation exposure limits set forth for an uncontrolled environment. This equipment should be installed and operated with a minimum distance of 20 cm between the radiator and your body. This transmitter must not be co-located or operating in conjunction with any other antenna or transmitter.

Cet équipement est conforme a RSS-102 limites énoncées pour un environne- ment non contrôlé. Cet équipement doit être installé et utilisé avec une distance minimale de 20 cm entre le radiateur et votre corps. This Class B digital apparatus complies with Canadian ICES-003 Cet appareil numérique de Classe B est conforme à la norme Canadienne ICES-003.

FCC Information to the user

Note: This equipment has been tested and found to comply with the limits for a class B digital devices, pursuant to part 15 of the FCC Rules. These limits are designed to provide reasonable protection against harmful interference in a residential installation. This equipment generates, uses and can radiate radio

frequent energy and, if not installed and used in accordance with the instructions, may cause harmful interference to radio communications.

However, there is no guarantee that interference will not occur in a particular installation. If this equipment does not cause harmful interference to radio or television reception, which can be determined by turning the equipment off and on, the user is encouraged to try to correct the interference by one or more of the following measures:

- Reorient or relocate the receiving antenna.
- Increase the separation between the equipment and receiver.
- Connect the equipment into an outlet on a circuit different from that to which the receiver.

 Any changes or modifications not expressly approved by the party responsible for compliance could void the user's authority to operate the equipment. To ensure compliance with FCC regulations, use only the shielded interface cables provided with the product, or additional specified components or accessories that can be used with the installation of the product.

10 About Nedap

About

At Nedap Retail, we work around the globe to deliver industry-leading products, services and solutions for our customers' diverse needs in loss prevention, stock management and store monitoring. Our inventive thinking and collaborative spirit allows us to deliver tailor-made solutions for the fast paced retail sector.

We simplify retail management while improving your customers' shopping experience. By taking most recurring tasks off your hands, we create time for you to devote to your customers. And that is what retail is all about. Whether you run a small local store or a large international chain, you will benefit from our broad range of products, ideas and services.

Nedap solutions are built upon 40 years of global experience, market expertise and close cooperation with leading retailers. Our worldwide operations are supported by a flexible network of certified partners across the globe. Nedap systems are future-proof (RFID-ready), cost-efficient and eco-friendly. Our mission is simply to make sure your customers maintain the best shopping experience whilst we help you protect your profits. Our philosophy: "your store - our store."

Contact

If you need any further details or require help in preparing an installation, executing an installation or servicing an installation you are always welcome to contact our support team at:

support-retail@nedap.com

Suggestions for improving our products and documentation are of course always welcome.

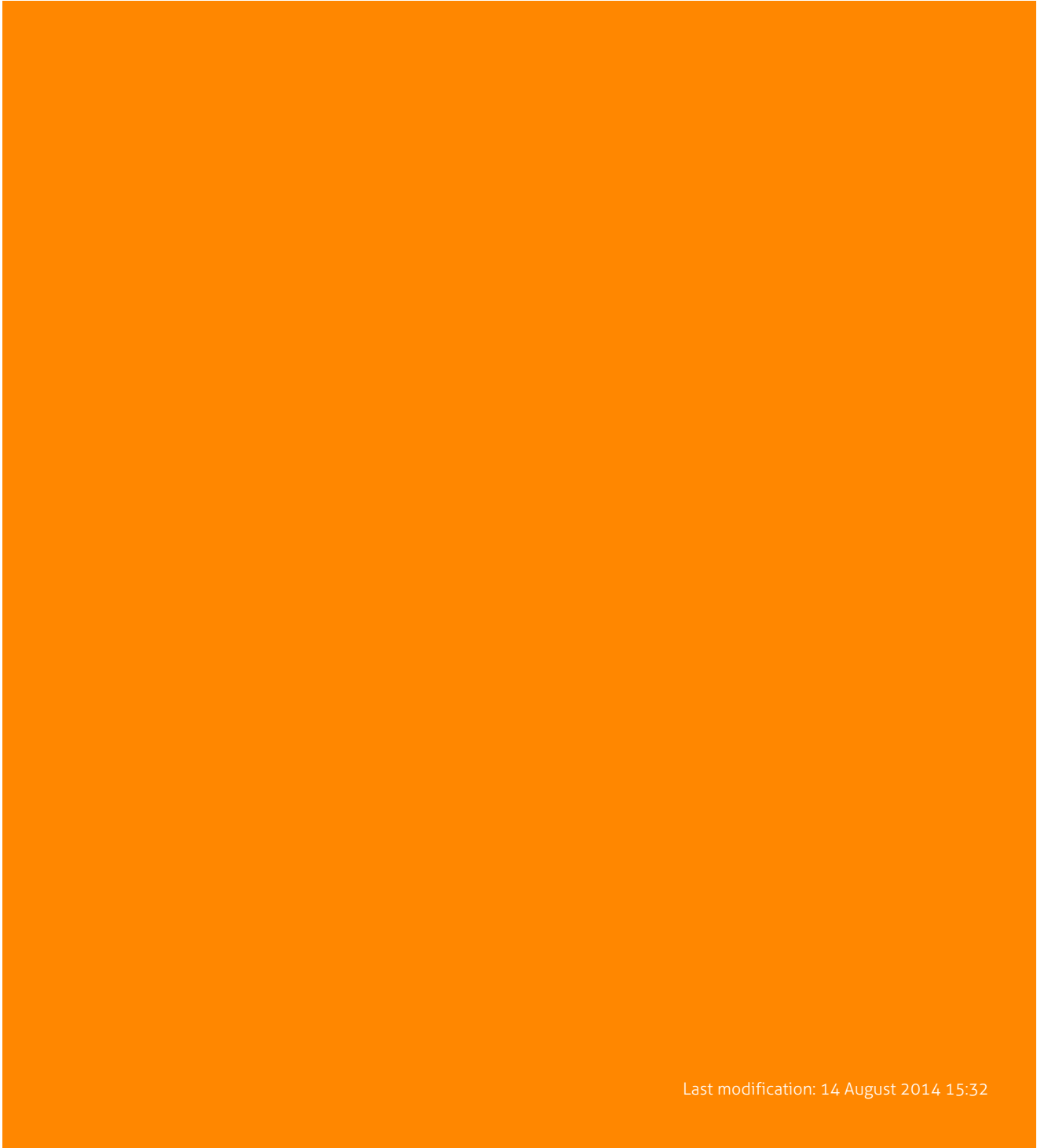

Last modification: 14 August 2014 15:32