

SENSIT

Installation Guide



2013-10-09

This information is furnished for guidance, and with no guarantee as to its accuracy or completeness; its publication conveys no license under any patent or other right, nor does the publisher assume liability for any consequence of its use; specifications and availability of goods mentioned in it are subject to change without notice; it is not to be reproduced in any way, in whole or in part, without the written consent of the publisher.

CONTENTS

1	INTRODUCTION	3
1.1	SENSIT IR.....	3
1.2	SENSIT Flush Mount.....	3
1.3	SENSIT Surface Mount	3
2	SENSIT IR	4
2.1	SAFETY PRECAUTIONS.....	4
2.2	DETECTION	4
2.3	DIMENSIONS	4
2.4	INSTALLATION CONDITIONS.....	5
2.5	REQUIRED INSTALLATION MATERIALS	5
2.6	INSTALLATION PROCEDURE	5
2.7	REPLACEMENT	6
3	SENSIT FLUSH MOUNT	8
3.1	SAFETY PRECAUTIONS.....	8
3.2	DETECTION	8
3.3	DIMENSIONS	8
3.4	INSTALLATION CONDITIONS.....	8
3.5	INSTALLATION MATERIAL	8
3.6	INSTALLATION PROCESS.....	9
3.7	REPLACEMENT	9
4	SENSIT SURFACE MOUNT.....	10
4.1	SAFETY PRECAUTIONS.....	10
4.2	DETECTION	10
4.3	DIMENSIONS	10
4.4	MODIFIED SILICON POLYMER	12
4.5	POLYURETHAAN (PUR).....	12
4.6	INSTALLATION MATERIAL	12
4.7	INSTALLATION PROCESS.....	13
4.8	REPLACEMENT	15
5	PROJECT SUPPORT	17
5.1	SITE SURVEY & INSTALLATION ADVICE.....	17
5.2	ON-SITE CERTIFICATION.....	17
6	FCC AND IC DECLARATION.....	18
6.1	Compliance statements (part15.19)	18
6.2	Warning (part15.21).....	18
6.3	RF Exposure (OET Bulletin 65).....	18
6.4	Information to the User (Part 15.106(b)).....	18
7	TECHNICAL SPECIFICATIONS	19
A	PART NUMBERS	20
B	RAPID MORTAR.....	21
C	Modified Silicon Polymer	22
D	POLYURETHAN.....	23

1 INTRODUCTION

The SENSIT vehicle detection system facilitates accurate measurement on occupancy of individual parking spaces in car parks, and on-street parking spaces. This information can be used to guide traffic to free parking spaces but can also be used for on-street parking enforcement and overstay detection. For on-street enforcement the number of occupied parking spaces can be compared with the number of payments realized by the pay station. For overstay detection the system alerts instantly a parking officer to the presence of nearby overstaying vehicles. Based on this information you can exactly determine which space to enforce.

All the SENSIT vehicle detection sensors are featured with detection and communicate wireless, creating their own network. The SENSIT sensors do not require power wiring, in contrast to conventional systems that require wiring throughout the car park and mounting onto the ceiling.

Easy installation of the sensors is guaranteed. Once installed no maintenance is required for years. The actual status (occupancy) of the sensor is transmitted to the Relay Node, which is part of the wireless mesh network.

Different types of ruggedly designed sensors are available to accommodate installation in indoor car parks, on-street spaces and road surfaces.

1.1 SENSIT IR

Vehicle detection sensor featured with dual detection technology (infrared and earthmagnetic field detection). The SENSIT IR is mounted into the floor of each parking space allowing for vandal proof installation, making the unit suitable for on-street application.

1.2 SENSIT Flush Mount

Vehicle detection sensor for flush mount installation with the road surface. The sensor is resistant to snow ploughs and offers vandal proof installation. The SENSIT Flush Mount is featured with earth magnetic field detection.

1.3 SENSIT Surface Mount

Vehicle detection sensor designed for car parks where drilling is not allowed or non permanent mounting is required. The unit is suitable for indoor car parks and rooftop parkings. The sensor can easily be glued onto the surface. Replacement can be achieved by removing the sensor installed in the mounting ring. The SENSIT Flush Mount is featured with dual detection technology (infrared and earth magnetic field).

2 SENSIT IR

2.1 SAFETY PRECAUTIONS

The following safety precautions should be observed during normal use, service and repair.

- The SENSIT IR may only be installed and serviced by qualified service personnel.
- To be sure of safety, do not modify or add anything to the SENSIT IR other than mentioned in this manual or indicated by NEDAP N.V.

2.2 DETECTION

The SENSIT IR is featured with earthmagnetic field and infrared detection.

2.3 DIMENSIONS

The SENSIT IR is designed for mounting into the floor of a parking space. See Figure 1 for the dimensions of the unit in mm. The top of the SENSIT IR is laser engraved with the node ID number, see Figure 2.

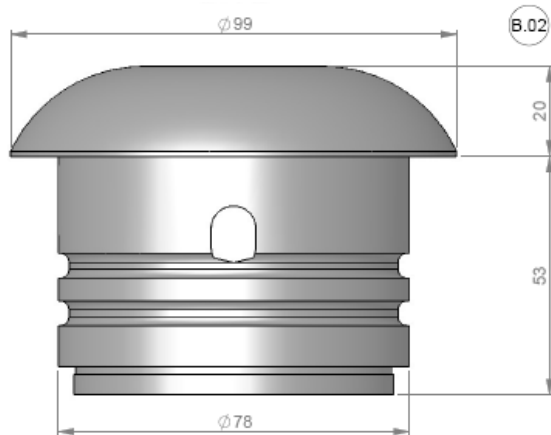

Figure 1: Dimensions SENSIT IR

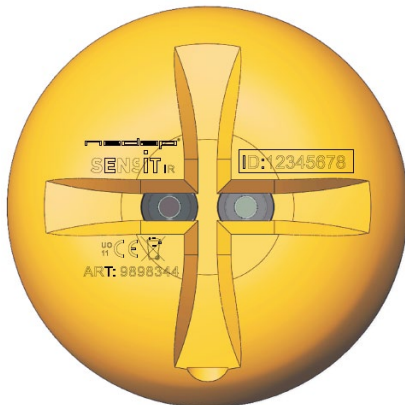

Figure 2: Top laser engraved side of the SENSIT IR

The node ID is mentioned on the bottom of the housing under ID. There is also a 125kHz passive RFID label embedded into the SENSIT IR. This can be used for verification of the SENSIT IR or to localize the SENSIT IR on the parking lot.

2.4 INSTALLATION CONDITIONS

The installation recommendation is based on the following environmental conditions;

- Ambient temperature between 5 to 40 °C [41 to 104 °F]
- Dry weather conditions
- Surface based on concrete, asphalt or pavement

2.5 REQUIRED INSTALLATION MATERIALS

The following would be required for mounting of the SENSIT IR.

- Equipment: Automatic drill
- Drill size: Dimensions Ø 85 mm [3.35 in]
- Drill depth: 54 mm [2.13 in]
- Filler material: Liquid rapid mortar
- Required amount per sensor: Approx 100 ml

We have good results with the rapid mortar TM 5R. See appendix B for specifications. Ensure to follow the guidelines and instructions as outlined on the filler material.

2.6 INSTALLATION PROCEDURE

Below the mounting procedure for the SENSIT IR. Write the ID number of the installed SENSIT on the installation plan.

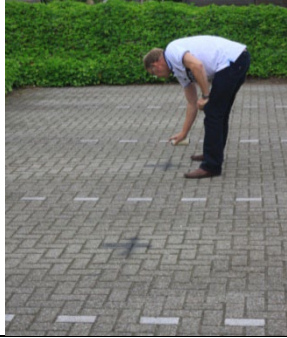
<p>STEP 1</p> <p>Close off the parking area</p>
<p>STEP 2</p> <p>Indicate where the sensor should be positioned. Distribute the SENSIT IR over the empty parking lot (without mounting them into the floor).</p> 
<p>STEP 3</p> <p>All SENSIT IR are set to transport/stock mode during shipment. Prior to installation all SENSIT IR must be swept with the reset magnet over the left bottom part of the sensor indicating the ART: XXXXXX and CE marking as indicated in Figure 2. This will give the SENSIT IR a reset. Please ensure to use a strong magnet (Neodymium).</p> <hr/> <p><i>Note: Once out of the transport/stock mode the battery lifetime starts to count.</i></p> <hr/>
<p>STEP 4</p> <p>Write down the node ID number on your installation plan so you are sure which SENSIT IR is positioned in which parking bay.</p>
<p>STEP 5</p> <p>Verify if all the SENSIT IR are online and if communication is received by the Data Collector after the magnet sweep. Do this prior to mounting the units into the ground.</p> <hr/> <p><i>Note: Only once all SENSIT IR are live and seen in the software they can be installed into the pavement.</i></p> <hr/>

STEP 6

Drill a hole of 85 mm [3.35 in] into the centre of the parking bay.

**STEP 7**

Apply the right amount of filler and pour into the hole.

**STEP 8**

Double-check the node ID number and the parking bay on the installation plan and place the SENSIT IR into the hole. Take attention that you fixate the SENSIT during the curing time otherwise the SENSIT will start to float.

**STEP 9**

After installation the SENSIT IR must be calibrated. Ensure that the parking space is empty and that there is no car parked on top of the sensor or on neighbouring parking bays. Also ensure not metal parts (such as tools) are positioned in the surrounding of the sensors as this might affect calibration. See InstallGuide SIM Software for more information on calibration.

Note: When the SENSIT IR are not calibrated they hardly send any messages. This is due to the fact that there are no events generated because the magnetic tressholds are not crossed.

STEP 10

Leave the filler harden for 8 hours before vehicles are allowed in the parking space again.



2.7 REPLACEMENT

When the battery life of the SENSIT IR fails after specified life time, we advise to replace the unit completely. The SENSIT IR is fully sealed and for outdoor use therefore batteries cannot be replaced.

Drill out the old SENSIT IR and complete the mounting procedure as describe in the previous paragraph.

Ensure to note the node ID number of the SENSIT IR to the parking bay. Update the parking bay configuration list in the SIM software to ensure the new sensor is linked to the right parking bay.

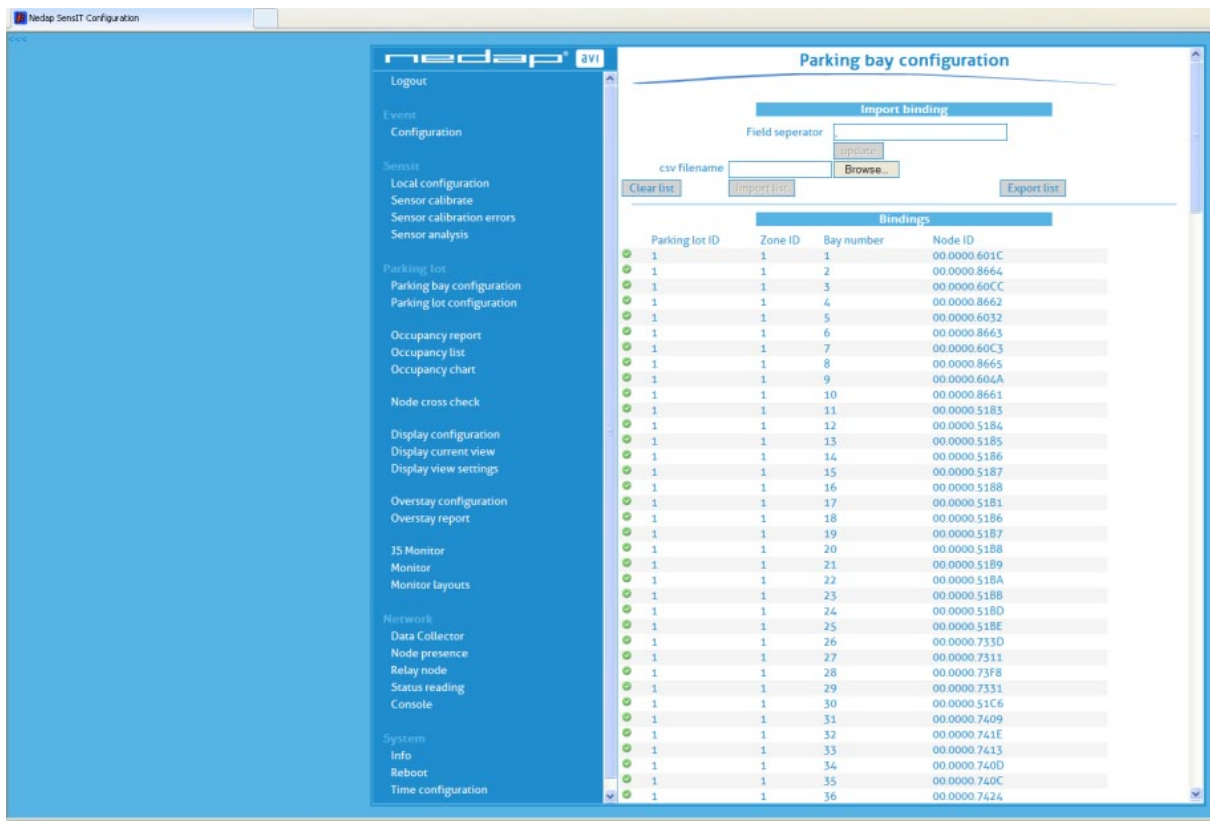

Figure 3: Screenshot parking bay configuration

3 SENSIT FLUSH MOUNT

3.1 SAFETY PRECAUTIONS

The following safety precautions should be observed during normal use, service and repair.

- The SENSIT Surface Mount may only be installed and serviced by qualified service personnel.
- To be sure of safety, do not modify or add anything to the SENSIT Surface Mount other than mentioned in this manual or indicated by NEDAP N.V.

3.2 DETECTION

The SENSIT Flush mount is featured with earth magnetic field detection.

3.3 DIMENSIONS

The SENSIT Flush Mount is designed for full mounting into the floor of a parking space. As the unit is fully flush with the road surface the unit is snow plough resistant. The SENSIT Flush Mount is only featured with magnetic detection. See Figure 1 for the dimensions of the unit in mm. The top of the SENSIT Flush Mount is laser engraved with the node ID number.

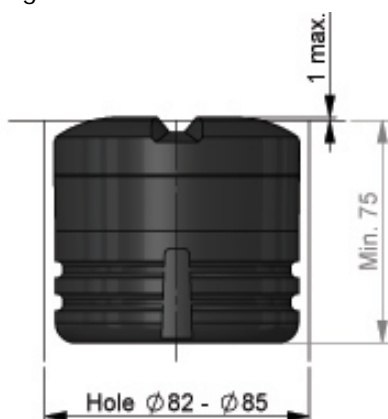

Figure 4: Dimensions SENSIT Flush mount

The node ID is mentioned on the top of the housing under ID. There is also a 125kHz passive RFID label embedded into the SENSIT Flush Mount. This can be used for verification of the SENSIT or to localize the SENSIT on the parking lot.

Figure 5: Lasermarking SENSIT Flush Mount

3.4 INSTALLATION CONDITIONS

The installation recommendation is based on the following environmental conditions;

- Ambient temperature 5 to 40 °C [41...104 F]
- Dry weather conditions
- Surface based on concrete, asphalt or pavement
- Surface needs to be dry and clean (oil, grease and dust free). The surface can easily be cleaned using IPA (ISO Propanol Alcohol).

3.5 INSTALLATION MATERIAL

The following would be required for mounting of the SENSIT IR.

- Equipment: Automatic drill
- Drill size: Dimensions Ø 85 mm [3.35 in]
- Drill depth: 73 mm [3.35 in]
- Filler material: Liquid concrete mortar
- Required amount per sensor: Approx 100 ml

We have good results with the rapid mortar TM 5R. See appendix B for specifications. Ensure to follow the guidelines and instructions as outlined on the filler material.

3.6 INSTALLATION PROCESS

Installation process as described in paragraph 2.6, however with above mentioned drilling depth.

3.7 REPLACEMENT

When the battery life of the SENSIT Flush Mount fails after specified life time, we advise to replace the unit completely. The SENSIT Flush Mount is fully sealed, therefore batteries cannot be replaced. Drill out the old SENSIT Flush Mount and complete the mounting procedure as described in paragraph 2.6.

Ensure to note the node ID number of the SENSIT IR to the parking bay. Update the parking bay configuration list in the SIM software to ensure the new sensor is linked to the right parking bay as described in paragraph 2.7.

4 SENSIT SURFACE MOUNT

The SENSIT Surface Mount is designed for installations where the sensors cannot be drilled into the parking space (e.g. multi storey car parks and rooftop parkings) or existing car parks.

4.1 SAFETY PRECAUTIONS

The following safety precautions should be observed during normal use, service and repair.

- The SENSIT Surface Mount may only be installed and serviced by qualified service personnel.
- To be sure of safety, do not modify or add anything to the SENSIT Surface Mount other than mentioned in this manual or indicated by NEDAP N.V.

4.2 DETECTION

The SENSIT Surface Mount is featured with earth magnetic field and infrared detection.

4.3 DIMENSIONS

The SENSIT Surface Mount can easily be glued onto the surface of a parking space. The unit consists of two components;

- Sensor core; the black core is the vehicle detection sensor. This unit can be replaced after end of battery life.
- Mounting ring; the mounting ring allows easy installation onto the surface of a parking space.

See Figure 6 for the dimensions of the unit. The top of the SENSIT Surface Mount is laser engraved with the node ID number, see Figure 7.

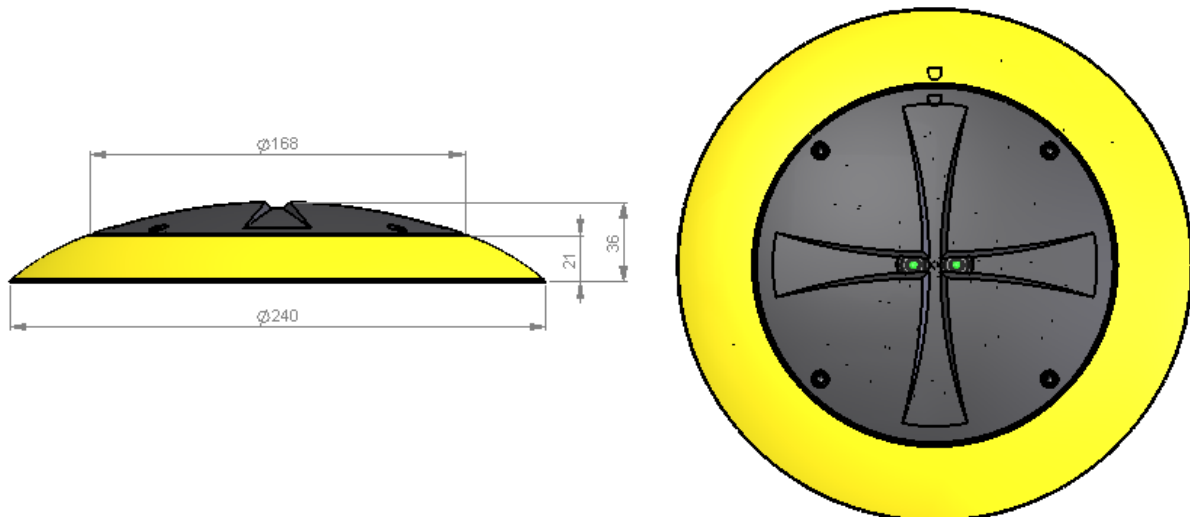

Figure 6: Dimensions SENSIT Surface Mount



Figure 7: Top laser engraved side of the SENSIT Surface Mount

The node ID is mentioned on the top of the housing under ID. There is also a 125kHz passive RFID label embedded into the SENSIT Surface Mount. This can be used for verification of the SENSIT or to localize the SENSIT on the parking lot.

4.4 MODIFIED SILICON POLYMER

We recommend the use MSP as glue to mount the SENSIT onto the following parking surfaces

Parking surfaces:	Concrete, asphalt, PU, epoxy/coating
Glue material:	MSP (Modified Silicon Polymer), see appendix C for more information
Amount required per sensor:	150 ml
Fixation time of the glue:	typical 4 hours at 20°C

The installation recommendation is based on the following environmental conditions;

- Ambient temperature >5° C
- Dry weather conditions
- Surface based on PU, Epoxy coating, concrete or asphalt
- Surface needs to be dry and clean (oil, grease and dust free). The surface can easily be cleaned using IPA (ISO Propanol Alcohol).
- Always follow the guideline and instructions as outlined on the glue material.

4.5 POLYURETHAAN (PUR)

In case the SENSIT is mounted onto a coated car park floor also the following glue can be applied on absolutely dry surfaces.

Parking surfaces:	PU, epoxy, coating
Glue material:	PUR (Polyurethaan), see appendix D for more information
Amount required per sensor:	150 ml
Fixation time of the glue:	typical 4 hours at 20°C

This recommendation is based on the following environmental conditions;

- Ambient temperature >5° C
- Absolutely dry weather conditions
- Surface based on PU, Epoxy coating
- Surface needs to be dry and clean (oil, grease and dust free). The surface can easily be cleaned using IPA (ISO Propanol Alcohol).
- Always follow the guideline and instructions as outlined on the glue material.

4.6 INSTALLATION MATERIAL

The following installation material is recommended for the mounting of the SENSIT Surface Mount onto the parking space.

- Pneumatic kit dispenser, to easily apply the glue easily onto the mounting ring



4.7 INSTALLATION PROCESS

Follow the recommended installation procedure for the SENSIT Surface Mount as described below.

STEP 1

Clean the location where the sensor should be mounted

STEP 2

Indicate where the sensor should be positioned. Distribute the SENSIT Surface Mount over the empty parking lot (without mounting them into the floor).

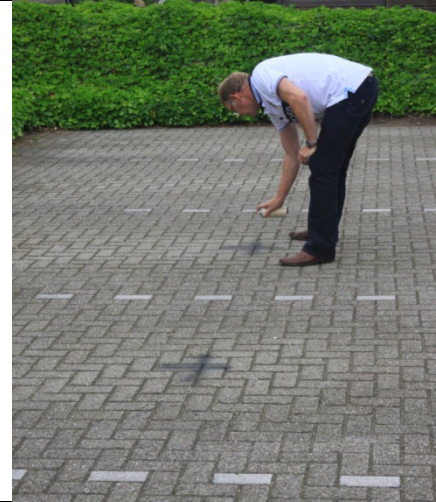

STEP 3

All SENSIT Surface Mount are set to transport/stock mode during shipment. Prior to installation all SENSIT Surface Mount must be swept with the reset magnet.

Swipe the reset magnet over the left bottom corner of the core part of the SENSIT Surface Mount indicating ART and CE marking.

This will give the SENSIT Surface Mount a reset. Please ensure to use a strong magnet (Neodymium).



Note: Once out of the transport/stock mode the battery lifetime starts to count.

STEP 4

Verify if all the SENSIT Surface Mount are online and if communication is received by the SENSIT Data Collector after the magnet sweep. Do this prior to mounting the units into the ground.

Note: Only once all SENSIT Surface Mounts are alive and seen in the software they can be installed onto the parking space.

STEP 5

Write down the node ID number on your installation plan so you know which SENSIT Surface Mount is positioned in which parking bay.

STEP 6

Pour the filler into the mounting ring of the SENSIT Surface Mount. A pneumatic kit dispenser makes it easy to apply the glue into the mounting ring. For good fixture with the surface please fill the entire mounting ring.

Note: Ensure excessive glue is removed from the bottom black core part of the unit, as this will make it very difficult to replace the core part.

Note: For non permanent mounting only glue the ring with a few dots of glue.

**STEP 8**

Flip the mounting ring with the SENSIT Surface Mount onto the parking space.

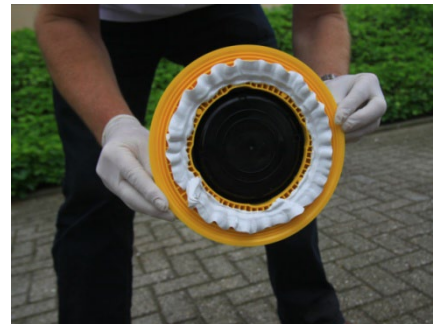
**STEP 9****STEP 10**

Press firmly.



STEP 11

After installation the SENSIT IR must be calibrated. Ensure that the parking space is empty and that there is no car parked on top of the sensor or on neighbouring parking bays. Also ensure not metal parts (such as tools) are positioned in the surrounding of the sensors as this might affect calibration. See InstallGuide SIM Software for more information on calibration.

Note: When the SENSIT Surface Mount are not calibrated they hardly send any messages. This is due to the fact that there are no events generated because the magnetic tresholds are not crossed.

STEP 12

Leave the glue dry for 4 hours before vehicles are allowed in the parking space again.

**4.8 REPLACEMENT**

When the battery life of the SENSIT Surface Mount fails after specified life time, we advise to replace the core. The core part of the SENSIT Surface Mount is fully sealed and for outdoor use therefore batteries cannot be replaced.

STEP 1: The mounting ring can remain positioned in the parking space. The core can be unscrewed using a torx. Unscrew the core by opening the 4 screws in the core part of the SENSIT Surface Mount using a T15 size bit screwdriver. Twist the core to lift up.

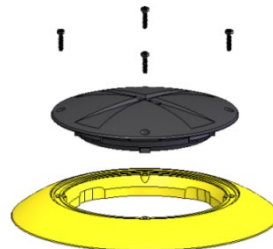

Figure 8: Removing core part of the SENSIT Flush Mount

STEP 2: Place a new core into the mounting ring by aligning the marks on the core part with the marks on mounting ring as indicated in figure 9. Push down the core and secure with 4 screws.

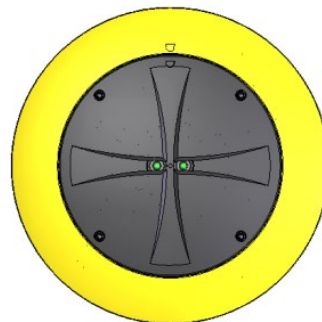

Figure 9: Align markers indicated on the sensor and mounting ring

STEP 3: Strongly push the core into the mounting ring. Screw the 4 screws back into the mounting ring.

- STEP 4:** After installation the SENSIT Surface Mount must be calibrated. Ensure that the parking space is empty and that there is no car parked on top of the sensor or on neighbouring parking bays.
- STEP 5:** Ensure to note the node ID number of the SENSIT Surface Mount to the parking bay and update the parking bay configuration list in the SIM software, see paragraph 2.7.

5 PROJECT SUPPORT

Based on our thorough project analysis including configuration and installation advice we can offer the customer the best AVI solution.

5.1 SITE SURVEY & INSTALLATION ADVICE

This will consist of an engineer visiting the site to visually inspect and analyze the location. We will then carry out calculations and provide you with detailed configuration and installation advice for the equipment for a specific project.

5.2 ON-SITE CERTIFICATION

An engineer will visit the site to inspect the installation of the equipment on reliable and accurate detection. Nedap engineers are not involved in installation (wiring) of any equipment. The installation must be completed before the engineer arrives on-site. We will ensure that the operation confirms our commissioning requirements, only on condition of prior given installation advice.

6 FCC AND IC DECLARATION

6.1 Compliance statements (part15.19)

This device complies with part 15 of the FCC Rules and to RSS210 of Industry Canada.

Operating is subject to the following two conditions:

- (1) This device may not cause harmful interference, and
- (2) This device must accept any interference received, including interference that may cause undesired operation.

Cet appareil se conforme aux normes RSS 210 exemptés de license du Industry Canada.

L'opération est soumis aux deux conditions suivantes:

- (1) cet appareil ne doit causer aucune interférence, et
- (2) cet appareil doit accepter n'importe quelle interférence, y inclus interférence qui peut causer une opération non pas voulu de cet appareil

6.2 Warning (part15.21)

Changes or modifications not expressly approved by party responsible for compliance could void the user's authority to operate the equipment.

6.3 RF Exposure (OET Bulletin 65)

To comply with FCC RF exposure requirements for mobile transmitting devices, this transmitter should only be used or installed at locations where there is at least 20cm separation distance between the antenna and all persons.

6.4 Information to the User (Part 15.106(b))

Note: This equipment has been tested and found to comply with the limits for a class B digital device, pursuant to part 15 of the FCC Rules. These limits are designed to provide reasonable protection against harmful interference in a residential installation. This equipment generates uses and can radiate radio frequent energy and, if not installed and used in accordance with the instructions, may cause harmful interference to radio communications.





However, there is no guarantee that interference will not occur in a particular installation. If this equipment does not cause harmful interference to radio or television reception, which can be determine by turning the equipment off and on, the user is encouraged to try to correct the interference by one or more of the following measures:

- Reorient or relocate some node
- Consult the dealer or an experienced radio/TV technician for help.

7 TECHNICAL SPECIFICATIONS

Technical info	SENSIT IR	SENSIT Surface Mount	SENSIT Flush Mount
Product			
Operating frequency	868 MHz (Europe) 902 – 928 MHz (US) 915 – 928 MHz (AUS)	868 MHz (Europe) 902 – 928 MHz (US) 915 – 928 MHz (AUS)	868 MHz (Europe) 902 – 928 MHz (US) 915 – 928 MHz (AUS)
Detection	Magnetic and IR	Magnetic and IR	Magnetic
Detection accuracy	98%	98%	95%
Mounting	Into the floor	Glued onto the floor	Into the floor, flush with the surface
Snowplough resistant	No	No	Yes
Load resistance	Heavy traffic	Regular traffic	Heavy traffic
Mounting dimensions	Ø 78 mm [3.07 in] and 53 mm [2.09 in] high in the floor	Mounting ring: Ø 240 mm [9.45 in] Sensor: Ø 167 mm [6.57 in] and 35 mm [1.38 in] high	Ø 78 mm [3.07 in] and 72 mm [2.8 in] into the floor fully flush with the road surface
Weight	365 gram [12,87 oz]	455 gram [16.05 oz]	350 gram [12.35 oz]
Protection	IP67, completely sealed Housing PE	IP67, completely sealed Housing PE	IP67, completely sealed Housing PE
Colour	Default black (optional yellow)	Sensor black Mounting ring yellow	Default black (optional yellow)
Operating temperature	-20 ... +85°C [-4...+185°F]	-20 ... +85°C [-4...+185°F]	-20 ... +85°C [-4...+185°F]
Storage temperature	-20 ... +85°C [-4...+185°F]	-20 ... +85°C [-4...+185°F]	-20 ... +85°C [-4...+185°F]
Detection height	0 ... 90 cm [0 ... 35.5 in]	0 ... 90 cm [0 ... 35.5 in]	0 ... 90 cm [0 ... 35.5 in]
Communication range			
Sensor to Sensor	max. 10 meters [33 ft]	max. 10 meters [33 ft]	max. 10 meters [33 ft]
Sensor to Relay Node	max. 25 meters [82 ft]	max. 25 meters [82 ft]	max. 25 meters [82 ft]
Sensor to Data Collector	max. 25 meters [82 ft]	max. 25 meters [82 ft]	max. 25 meters [82 ft]
Required Relay Nodes	Car parks: 1 per 50 sensors On-street parking: 1 per 25 sensors	Car parks: 1 per 50 sensors On-street parking: 1 per 25 sensors	1 per 25 sensors
Power supply	Built in lithium battery	Built in lithium battery	Built in lithium battery
Expected lifetime	5-10 years*	5- 9 years*	5-10 years*

A PART NUMBERS

SENSIT Vehicle Detection sensors		
	SENSIT IR EU yellow	part number: 9898344
	SENSIT IR US yellow	part number: 9955909
	SENSIT IR AU yellow	part number: 9965947
	SENSIT IR EU black	part number: 9943374
	SENSIT IR US black	part number: 9898620
	SENSIT IR AU black	part number: 9965955
	SENSIT Flush Mount EU black	part number: 9966960
	SENSIT Flush Mount US black	part number: 9966978
	SENSIT Flush Mount AU black	part number: 9966986
	SENSIT Flush Mount EU yellow	part number: 9966510
	SENSIT Flush Mount US yellow	part number: 9966528
	SENSIT Flush Mount AU yellow	part number: 9966536
	SENSIT Surface Mount EU	part number: 9958525
	SENSIT Surface Mount US	part number: 9958533
	SENSIT Surface Mount AU	part number: 9963871
	SENSIT ACTIVATION MAGNET	part number: 3062198

For full product information visit www.nedapavi.com

B RAPID MORTAR

RAPID MORTAR TM 5R

100706-06

Product description

Rapid mortar TM 5R is produced of a cement with a very high reactivity to water, and quartz sand with a maximum aggregate of 0.4 mm. Special synthetic components provide for good adhesion to the surface. Rapid mortar TM 5R exhibits high strength within a very short period of time.

Application

Rapid mortar TM 5R is used for repairing concrete and concrete units, which have to be back in operation in a short period of time, i.e.:

- repairs of manhole covers and drains in road construction
- assembly of parking meters and road signs

User instructions

Rapid mortar TM 5R is prepared with water until a plastic mortar is obtained. The water is filled into the mixer first, and then Rapid mortar TM 5R is added. For every 25 kg of Rapid mortar TM 5R about 3.75 litres of water are added. Mixing time is about 3 minutes after which the mortar is applied using appropriate tools. The processing time is about 15 minutes at a temperature of 20°C.

Yield

2 kg SchnellMortar TM 5R prepared with water will yield about 1 litre mortar.

Technical data

- State of aggregation: powder
- Colour: grey
- Density (kg/l): n.a.
- pH-Value: n.a.
- max. alkali content (% Na₂O-eq): n.a.
- max. chloride content (%): n.a.
- Colour code: n.a.
- Storage: dry, frost-protected, in closed packaging
- Shelf-life: when stored correctly at least 6 months after date of production

Packaging

Sacks, pallets, big bags.

Preliminary tests for the product's suitability are indispensable

Article number 5115

Tillman B.V. - Julianaweg 12 - 7078 AR Megchelen Gld.NL - tel. +31(0)315377541 - fax. +31(0)315377577 - info@tillman.nl - www.tillman.nl

C Modified Silicon Polymer

Sabatack Fast ultra-fastbonding

Description

Sabatack Fast is an ultra fast-acting 2-component, elastic, humidity-curing, MS polymer-based construction adhesive. Its primary use is bonding with fast hardening, handling after only 2 hours, which makes this product excellent for use in mass production. Sabatack Fast has a medium viscosity and a high modulus elasticity.

Field of application

Industrial and hand-made vehicle and coachwork construction, marine, ventilation and air conditions, electro-technology, equipment assembly, metal and tin processing, plastics technology, civil & environmental engineering and building & construction. For the elastic bonding of frames, profiles, plates etc. Also for sealing seams, overlaps, joints and cracks. Suitable for interior and exterior use. Excellent for use in mass production.

Advantages

- fast and controlled curing, high end strength
- adhesion without primer, fast drying
- can be painted wet-on-wet, hardly any shrinkage
- no blistering, almost odourless
- free from solvents, isocyanates and silicones
- UV-stable, high temperature resistance
- certificates: Wheelmark (164.106/1121/WCL MED0326), ISEGA (in connection with HACCP)

Method of use

For instructions for use, repaintability and pre-treatment, see the relevant info sheets at www.saba.nl

TECHNICAL DATA

Order information

Other packaging and colours on request. The shelf life may vary for large packaging.

Safety recommendations

For more information about safety, see the relevant SABA safety data sheet.

Component A Component B

Basis	MS polymer, humidity-curing MS polymer, humidity-curing
Density	(EN 542) approx. 1.380 kg/m ³ approx. 1.144 kg/m ³
Solids content	approx. 100% approx. 85%
Open time	(23 °C, 50% RLV) approx. 10 minutes
Tack free	(23 °C, 50% RLV) completely after approx. 12 hours
Cure rate	(23 °C, 50% RLV) even after 48 hours
Hardness Shore A (EN ISO 868)	approx. 55
Volume alteration (EN ISO 10563)	< 5%
Modulus at 100% (ISO 37/DIN 53504)	approx. 1.5 N/mm ²
Tensile strength (ISO 37/DIN 53504)	approx. 2.6 N/mm ²
Elongation at break (ISO 37/DIN 53504)	approx. 330%
Shear strength (ISO 4587)	approx. 1.7 N/mm ²
Working temperature	min. +5 °C to max. +35 °C
Storage temperature	min. +5 °C to max. +25 °C
Temperature resistance	min. -40 °C to max. +120 °C
Short temperature resistance	max. +180 °C (30 minutes)
Packaging	dual-cartridge
Contents	490 ml (contains 7 items)
Colour	white (similar to RAL 9003) black (similar to RAL 9011)
Article No.	100201 DJW 100862 DJW
Shelf life	9 months (in unopened packaging)

D POLYURETHAN

PERMAPUR® 2654 A/B

Universal Polyurethane liquid adhesive

PERMAPUR® 2654 A/B consists of two components A-component (Polyol) and a B-component (Isocyanate). The resin is supplied in a bi-pack. PERMAPUR 2654 A/B is used as an universal polyurethane resin which can be applied by pouring the fluid. The system is insensitive to moist and shows no blistering and is therefore less critical in processing.

Technical details

Color:	A-component black fluid B component dark brown fluid
Color mix:	Black
Processing time:	10 min / 20°C
Gel time:	15 min / 20°C
Curing time:	24 h /20°C
Viscosity:	4.500 mPa.sec/20°C
Hardness:	45° Shore D
Specific gravity:	1,5 g/cm ³
Specific resistance:	1 x 10 ¹⁴ W.cm
Breakdown voltage:	20 KV/mm
Max. temperature:	-25°C tot +120°C
Water absorption:	<1%
Storage:	At room temperature (20 ° C) in tightly closed Verpa Branching 12 months