

Wireless Space Count

Manual SENSIT IR



2009-11-23

This information is furnished for guidance, and with no guarantee as to its accuracy or completeness; its publication conveys no license under any patent or other right, nor does the publisher assume liability for any consequence of its use; specifications and availability of goods mentioned in it are subject to change without notice; it is not to be reproduced in any way, in whole or in part, without the written consent of the publisher.

CONTENTS

1	INTRODUCTION.....	3
1.1	SENSIT IR.....	3
2	INSTALLATION SENSIT IR	4
2.1	SAFETY PRECAUTIONS.....	4
2.2	DIMENSIONS.....	4
2.3	REPLACEMENT	4
2.4	MOUNTING PROCEDURE SENSIT IR.....	5
3	PROJECT SUPPORT	7
3.1	SITE SURVEY & INSTALLATION ADVICE.....	7
3.2	ON-SITE CERTIFICATION.....	7
4	FCC AND IC DECLARATION.....	8
4.1	Compliance statements (part15.19)	8
4.2	Warning (part15.21)	8
4.3	RF Exposure (OET Bulletin 65).....	8
4.4	Information to the User (Part 15.106(b))	8
5	TECHNICAL SPECIFICATIONS.....	9
A	PART NUMBERS.....	10

1 INTRODUCTION

The Wireless Space Count system facilitates accurate measurement on occupancy of individual parking spaces in car parks, and on-street parking spaces. This information can be used to guide traffic to free parking spaces but can also be used for on-street parking enforcement and overstay detection. For on-street enforcement the number of occupied parking spaces can be compared with the number of payments realized by the pay station. For overstay detection the system alerts instantly a parking officer to the presence of nearby overstaying vehicles. Based on this information you can exactly determine which space to enforce.

1.1 SENSIT IR

The SENSIT IR is mounted into the floor of each parking space. The SENSIT IR is suitable for floor mounting as well outdoor as indoor. The SENSIT IR are featured with detection and communicate wireless with each other, creating their own network. The SENSIT IR do not require power wiring, in contrast to conventional systems that require wiring throughout the car park and mounting onto the ceiling.

2 INSTALLATION SENSIT IR

2.1 SAFETY PRECAUTIONS

The following safety precautions should be observed during normal use, service and repair.

- The SENSIT IR may only be installed and serviced by qualified service personnel.
- To be sure of safety, do not modify or add anything to the SENSIT IR other than mentioned in this manual or indicated by NEDAP N.V.

2.2 DIMENSIONS

The SENSIT IR is designed for mounting into the floor of a parking space. See Figure 1 for the dimensions of the unit in mm. The bottom of the SENSIT IR is laser engraved with the node ID number, see Figure 2.

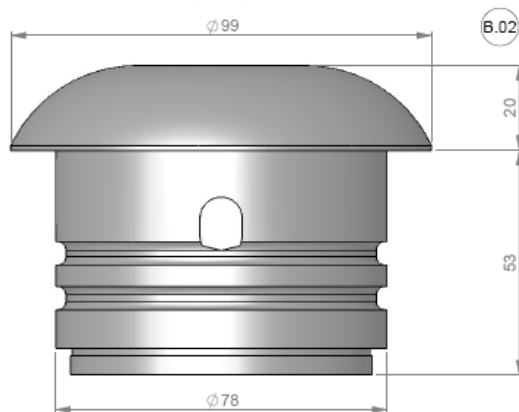

Figure 1: Dimensions SENSIT IR

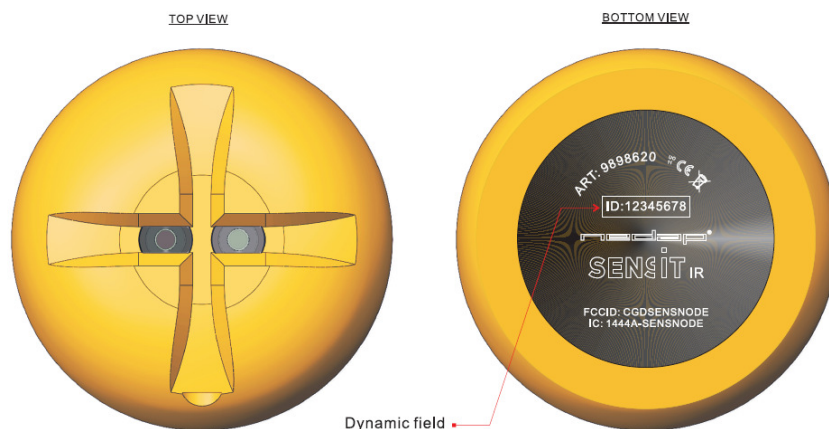

Figure 2: Top and bottom laser engraved side of the SENSIT IR

The node ID is mentioned on the bottom of the housing under ID. There is also a 125kHz passive RFID label embedded into the SENSIT IR. This can be used for verification of the SENSIT IR or to localize the SENSIT IR on the parking lot.

2.3 REPLACEMENT

When the battery life of the SENSIT IR fails after specified life time, we advise to replace the unit completely. The SENSIT IR is fully sealed and for outdoor use therefore batteries cannot be replaced.

Drill out the old SENSIT IR and complete the mounting procedure as describe in the next paragraph.

2.4 MOUNTING PROCEDURE SENSIT IR

Below the mounting procedure for the SENSIT IR.



<p>Step 1: Distribute the SENSIT IR over the empty parking lot (without mounting them into the floor).</p>	
<p>Step 2: All SENSIT IR are set to transport/stock mode during shipment. Prior to installation all SENSIT IR must be swept with a strong magnet. This will give the SENSIT IR a reset. Please ensure to use a strong magnet (Neodymium).</p> <p><i>Note: Once out of the transport/stock mode the battery lifetime starts to count.</i></p>	
<p>Step 3: Write down the node ID number on your installation plan so you are sure which SENSIT IR is positioned in which parking bay.</p>	
<p>Step 4: Verify if all the SENSIT IR are online and if communication is received by the SENSIT DATACOLLECTOR after the magnet sweep. Do this prior to mounting the units into the ground.</p> <p><i>Note: Only once all SENSIT IR are live and seen in the software they can be installed into the pavement.</i></p>	
<p>Step 5: Drill a hole of 85 mm (3.35 in) into the centre of the parking bay.</p>	<p>Figure 3: SENSIT IR installation</p> 
<p>Step 6: Use the right amount of filler</p>	<p>Figure 4: SENSIT IR installation</p> 
<p>Step 7: Double-check the node ID number and the parking bay on the installation plan and place the SENSIT IR into the hole</p>	

Figure 5: SENSIT IR installation

Step 8: After installation the SENSIT IR must be calibrated with no car on top of the sensor or on neighbouring parking bays.

Note: When the SENSIT IR are not calibrated they hardly send any messages. This is due to the fact that there are no events generated because the magnetic tresholds are not crossed.



Figure 6: Finished SENSIT IR installation

3 PROJECT SUPPORT

Based on our thorough project analysis including configuration and installation advice we can offer the customer the best AVI solution.

3.1 SITE SURVEY & INSTALLATION ADVICE

This will consist of an engineer visiting the site to visually inspect and analyze the location. We will then carry out calculations and provide you with detailed configuration and installation advice for the Wireless Space Count equipment for a specific project.

3.2 ON-SITE CERTIFICATION

An engineer will visit the site to inspect the installation of the equipment on reliable and accurate detection. Nedap engineers are not involved in installation (wiring) of any equipment. The installation must be completed before the engineer arrives on-site. We will ensure that the operation confirms our commissioning requirements, only on condition of prior given installation advice.

4 FCC AND IC DECLARATION

4.1 Compliance statements (part15.19)

This device complies with part 15 of the FCC Rules and to RSS210 of Industry Canada.

Operating is subject to the following two conditions:

- (1) This device may not cause harmful interference, and
- (2) This device must accept any interference received, including interference that may cause undesired operation.

4.2 Warning (part15.21)

Changes or modifications not expressly approved by party responsible for compliance could void the user's authority to operate the equipment.

4.3 RF Exposure (OET Bulletin 65)

To comply with FCC RF exposure requirements for mobile transmitting devices, this transmitter should only be used or installed at locations where there is at least 20cm separation distance between the antenna and all persons.

4.4 Information to the User (Part 15.106(b))

Note: This equipment has been tested and found to comply with the limits for a class B digital device, pursuant to part 15 of the FCC Rules. These limits are designed to provide reasonable protection against harmful interference in a residential installation. This equipment generates uses and can radiate radio frequent energy and, if not installed and used in accordance with the instructions, may cause harmful interference to radio communications.

However, there is no guarantee that interference will not occur in a particular installation. If this equipment does not cause harmful interference to radio or television reception, which can be determine by turning the equipment off and on, the user is encouraged to try to correct the interference by one or more of the following measures:



- Reorient or relocate some node
- Consult the dealer or an experienced radio/TV technician for help.

5 TECHNICAL SPECIFICATIONS

SENSIT IR (EU)		9898344
Operating frequency	868.2 MHz	
CE compliant	EN 60950-1 EN50357 and EN 50364 EN 301 4889-1 V1.6.1 and EN 301 489-3 V1.4.1 EN 61000-6.1, EN 61000-6-2 and 61000-6-3 EN 55011 Class B EN 61204-3 EN 300-220-1 ERV REC 70-03	
Dimensions	Ø 80 mm (3.15 inch) and 70 mm (2.8 inch)	
Weight	365 g (12.87oz)	
Protection	IP67, completely sealed housing	
Material	Black/Yellow Polyethylene	
Operational temperature	-20°C ... +85°C (-4°F ... +185°F)	
Storage temperature	-20°C ... +85°C (-4°F ... +185°F)	
Communication range	From sensor to sensor >10m (33 feet)	Dependent on the environment
Power supply	Built-in lithium battery	Expected battery life 5 years
Mounting	Into the floor of a parking space	
Detection	Magnetic and optic	
Detection height	90 cm (35.5 inch)	

SENSIT IR (US and Canada)		9898620
Operating frequency	902-928 MHz (FHSS)	
	FCCID: CGDSENSDATA IC: 1444A-SENSDATA	
Dimensions	Ø 80 mm (3.15 inch) and 70 mm (2.8 inch)	
Weight	365 g (12.87oz)	
Protection	IP67, completely sealed housing	
Material	Black/Yellow Polyethylene	
Operational temperature	-20°C ... +85°C (-4°F ... +185°F)	
Storage temperature	-20°C ... +85°C (-4°F ... +185°F)	
Communication range	From sensor to sensor >10m (33 feet)	Dependent on the environment
Power supply	Built-in lithium battery	Expected battery life 5 years
Mounting	Into the floor of a parking space	
Detection	Magnetic and optic	
Detection height	90 cm (35.5 inch)	

A PART NUMBERS

SENSIT IR		
	SENSIT IR (EU)	part number: 9898344
	SENSIT IR (US)	part number: 9898620

For full product information visit www.nedapavi.com