

MANUAL SMART DEAC

2009-06-25

Part#: 9937676

This information is furnished for guidance, and with no guarantee as to its accuracy or completeness;
Its publication conveys no license under patent or other right, nor does the publisher assume
Liability for any consequence of its use; specifications and availability of goods mentioned in it are
Subject to change without notice; it is not to be reproduced in any way, in whole or in part, without the written consent of the
publisher.

© N.V. Nederlandsche Apparatenfabriek "Nedap"

Technical Support

E-Mail

info-rs@nedap.com



Postal address



N.V. Nederlandsche Apparatenfabriek "NEDAP", Parallelweg 2, 7141DC, Groenlo, The Netherlands

Fax

+31 (0) 544-46 34 75

Safety precautions

	CAUTION RISK OF ELECTRIC SHOCK DO NOT OPEN	
CAUTION: TO REDUCE THE RISK OF ELECTRICAL SHOCK, DO NOT REMOVE COVER (OR BACK). NO USER-SERVICEABLE PARTS INSIDE. REFER SERVICING TO QUALIFIED NEDAP SERVICE PERSONNEL.		

	Lightning flash with an arrowhead, enclosed in a triangle, alerts you to the presence of uninsulated voltage points inside the product which could cause a serious electrical shock.
	An exclamation mark enclosed in a triangle alerts you to important operating and maintenance instructions in the documentation provided with the product.
WARNING! To avoid the risk of fire or electrical shock, never expose these products to water or operate in a high humidity environment.	

 EN 50419:2005	This European Standard specifies a marking <ul style="list-style-type: none">of electrical and electronic equipment in accordance with Article 11(2) of Directive 2002/96/EC (WEEE); This is in addition to the marking requirement in Article 10(3) of this Directive which requires producers to mark electrical and electronic equipment put on the market after 13 August 2005 with a 'crossed-out wheeled bin' symbol.that applies to electrical and electronic equipment falling under Annex IA of Directive 2002/96/EC, provided the equipment concerned is not part of another type of equipment that does not fall within the scope of this Directive. Annex IB of Directive 2002/96/EC contains an indicative list of the products, which fall under the categories set out in Annex IA of this Directive;that serves to clearly identify the producer of the equipment and that the equipment has been put on the market after 13 August 2005.
--	---

© 2009 N.V. Nederlandsche Apparatenfabriek "NEDAP" Parallelweg 2, NL-7141 DC Groenlo

The software / hardware described in this book / file is furnished under a license agreement and may be used only in accordance with the terms of the agreement.

Copyright Notice

All Rights Reserved. Any technical documentation that is made available by N.V. Nederlandsche Apparatenfabriek "NEDAP" is the copyrighted work of N.V. Nederlandsche Apparatenfabriek "Nedap" and is owned by N.V. Nederlandsche Apparatenfabriek "Nedap".

No warranty

The technical documentation is being delivered to you and Nedap makes no warranty as to its accuracy or use. Any use of the technical documentation or the information contained therein is at the risk of the user. Documentation may include technical or other inaccuracies or typographical errors Nedap the right to make changes without prior notice. No part of this publication may be copied without the express written permission of N.V. Nederlandsche Apparatenfabriek "Nedap" Parallelweg 2, NL-7141DC, Groenlo, Netherlands.

Trademarks

Nedap, the Nedap logo, Nedap EASi/Net and the Nedap EASi/Net are registered trademarks of Nedap N.V. Nederlandsche Apparatenfabriek "Nedap"

Other product names mentioned in this manual may be trademarks or registered trademarks of their respective companies and are hereby acknowledged.

Printed in the Netherlands

Notice

The documentation is based in a Part numbers and Drawing number structure.

Part number can also be named as Artikel nummer or Article number

Drawing numbers can also be named as: Tekening

Drawing numbers are build up in a the drawing Number with a structure Txxx-yy-zz

Txxx-yy is the drawing number and extension number zz means:

10 is an overview drawing of the part and can contain wiring and circuit diagrams;

11 is the bill of material;

12 is the circuit diagram of the device.

Xxxx = 0000 – 9999

yyy = 000-999

Table of content

1.	Introduction	1
2.	System overview	1
3.	Wiring diagram	1
4.	FCC Declarations	1
5.	Specifications SMART DEAC	1

1 Introduction

Thank's for purchasing the Nedap Pulse listen SMART DEAC

N.V. Nederlandsche Apparatenfabriek "Nedap" further on called Nedap manufactures some of the most reliable and scalable EAS Systems of the market today.

With this system your able to reduce the shoplifting costs the best in combination with Nedap's tag line. The SMART DEAC is meant for Deactivation of disposable tags according to the Pulse Listen method. It detects a tag in the field and shell try to deactivate it until it is not functioning anymore.

Some of the Smart Deactivator advantages are:

1. Constant optimal deactivation distance, independent of the tag frequency between 7.5 – 8.8 MHz
2. Different antenna sizes and shapes
3. Deactivation behavior programmable with switches
4. Detect only Mode
5. Deactivation on input
6. Forced deactivation on input
7. Short repeating acoustical feedback for successful deactivation, continue beep when deactivation unsuccessful
8. Prepared for connectivity in RS485 bus structure
9. Sends only a deactivation burst when a tag is detected
10. Through air synchronization with Nedap OS/T systems and other SMART DEAC 's
11. Solid state output

The SMART DEAC produces an acoustic and visual signal when it detects an operating tag and tries to deactivate it.

2 System overview

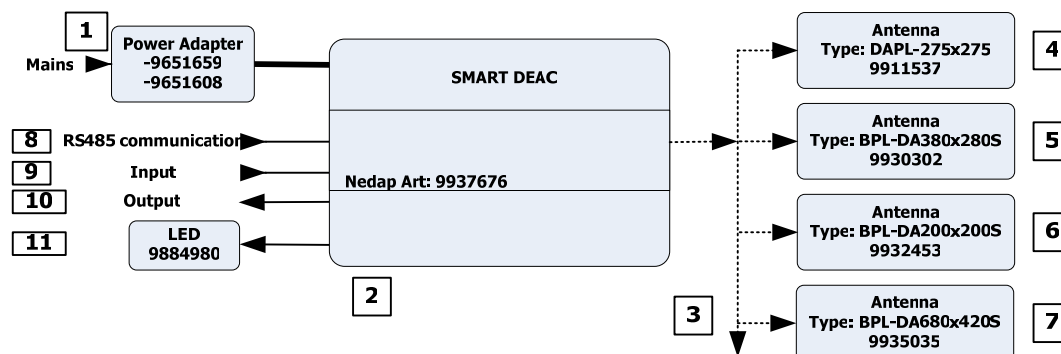

Figure 1 Functional system overview

The SMART DEAC system consists of the following components:

1. AC/DC Power adapter Wall Mount 100 – 240 VAC / 12 VDC Nedap article number: (9651659 or 9651608)
2. Smart Deactivator electronics (9937676)
3. Antenna Cable
4. Antenna Type: DAPL-275x275 (9911537)
5. Antenna Type: BPL-DA380x280S (9930302)
6. Antenna Type: BPL-DA200x200S (9932453)
7. Antenna Type: BPL-DA680x420S (9935035)
8. RS485 connection to communicate with the SMART DEAC
9. Input for to be defined functionality
10. Output to be defined functionality
11. LED for visual indication (9884980)

The SMART DEAC system is ready for use. You only have to follow the next steps:

- Install the Smart Deactivator system according to the: Prospect SMART DEAC;
- Power up the Smart Deactivator system;
- Check the functionality; by deactivating a Tag above the antenna and check the sound.
- Call Nedap Customer Support for quick hands-on problem solution in case of unforeseen trouble (see Technical Support);

3 Wiring Diagram

Schematically diagrams below shows an example of the connections between used modules. The picture shows the full configuration that can be built up.

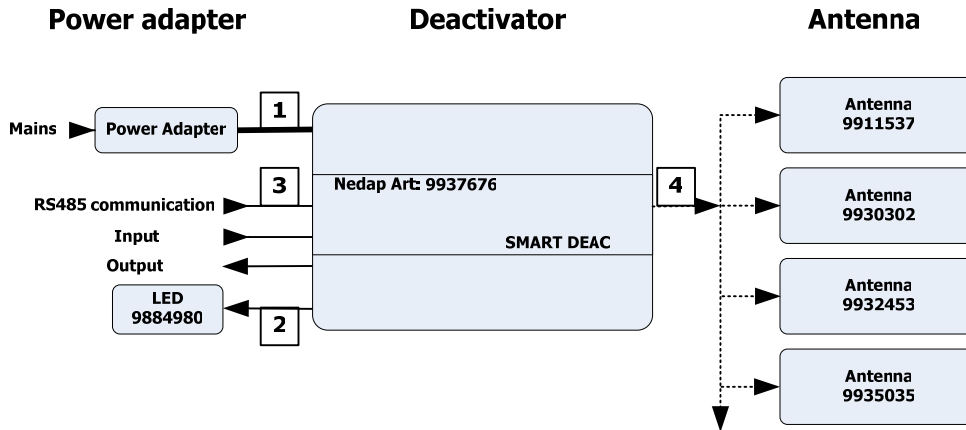

The connections for a full configuration are:

- 1 DC power line**
Connects 12VDC from the Power Adapter to the Electronics Unit (9937676)
- 2 LED cable**
Connects the SMART DEAC to the LED unit (9884980)
- 3 RS485 communication cable**
Connects the SMART DEAC to a RS485 host device for example a personal computer
- 4 Antenna cable**
Connects the SMART DEAC to one of the antennas.
(9911537, 9930302, 9932453)

4 FCC Declarations

Compliance statements (part15.19)

This device complies with part 15 of the FCC Rules and to RSS210 of Industry Canada.

Operating is subject to the following two conditions:

- (1) this device may not cause harmful interference, and
- (2) this device must accept any interference received, including interference that may cause undesired operation.

Warning (part15.21)

Changes or modifications not expressly approved by party responsible for compliance could void the user's authority to operate the equipment.

This in particular is applicable for the antenna which can be delivered with the SMART DEAC System.

RF Exposure (OET Bulletin 65)

To comply with FCC RF exposure requirements for mobile transmitting devices, this transmitter should only be used or installed at locations where there is at least 20cm separation distance between the antenna and all persons.

Information to the User (Part 15.106(b))

Note: This equipment has been tested and found to comply with the limits for a class B digital devices, pursuant to part 15 of the FCC Rules. These limits are designed to provide reasonable protection against harmful interference in a residential installation. This equipment generates, uses and can radiate radio frequent energy and, if not installed and used in accordance with the instructions, may cause harmful interference to radio communications.

However, there is no guarantee that interference will not occur in a particular installation. If this equipment does not cause harmful interference to radio or television reception, which can be determine by turning the equipment off and on , the user is encouraged to try to correct the interference by one or more of the following measures:

- Reorient or relocate the receiving antenna.
- Increase the separation between the equipment and receiver.
- Connect the equipment into an outlet on a circuit different from that to which the receiver is connected.
- Consult the dealer or an experienced radio/TV technician for help.

5 Specifications SMART DEAC

Environmental

Description				
Material Construction	Aluminium			
Protection Class	IP20			
	Min.	Typical	Max.	Condition
Operating frequency	7.5 MHz	8.2	8.8 MHz	
Operational temperature	0°C		40 °C	
Storage temperature	-10°C		+70°C	
Relative Humidity	20%		90%	non-condensing
Operating Distance		0.3m		Antenna type dependant, Tag dependant

Input Requirements and electrical specifications

Description	Min.	Typical	Max.	Condition
Input Voltage	90VAC	100-240	264VAC	Full Range; 50/60Hz
Input Current	0.35A	-	0.7A	264VAC - 90VAC
Line Frequency	47 Hz	50-60Hz	63Hz	-
Inrush Current @25°C				230VAC Cold Start
Operation Voltage	11.64VDC	12VDC	12.6VDC	
Power		6W		230VAC 50Hz

Regulations

Safety approvals of the Power Adapter:

- cULus according to UL/CSA 60950-1
- CB according to IEC60950-1
- TUV EN60950-1 (2006)
- NEC Class 2 according to UL1310
- CE Europe according to EN60950-1
- Japan PSE

Telecom system approval

- Canada IC ID according to RSS210 IC ID:1444A-SMARTDEAC
- US according to FCC Part 15 FCC ID:CGDSMARTDEAC
- CE according to EN300330
- Japan pending

In compliance with Human exposure assessment according to:

- EN62369-1 and EN50364
- ICNIRP Guidelines
- IEEE C95.1
- RSS102
- ARIB STD-38
- IEC62369-1

Electromagnetic compatibility

- EN 301 489 (Emission according to EN55022)
- IEC 61000-6-2
- IEC 61000-6-3
- CISPR 22