 retail	GROENLO - HOLLAND	DRW: CB 2013/05/29
		CHK:
DESCRIPTION:		DOC. ARTICLE NO: 9741224
QUICK REFERENCE !D POS		REV. : A.02
Copyright © by N.V. Nederlandsche Apparatenfabriek NEDAP. No part of this drawing may be reproduced or distributed in any form or by any means, or stored in a data base or retrieval system without the prior written permission of NEDAP.		SHEET: 45.01 OF 1
		DRAWING: T9741-224

ID POS connections

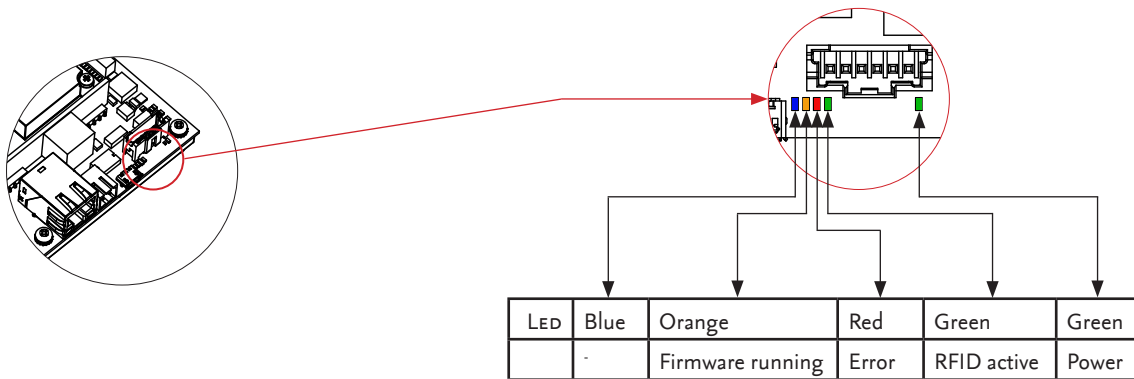

place cover

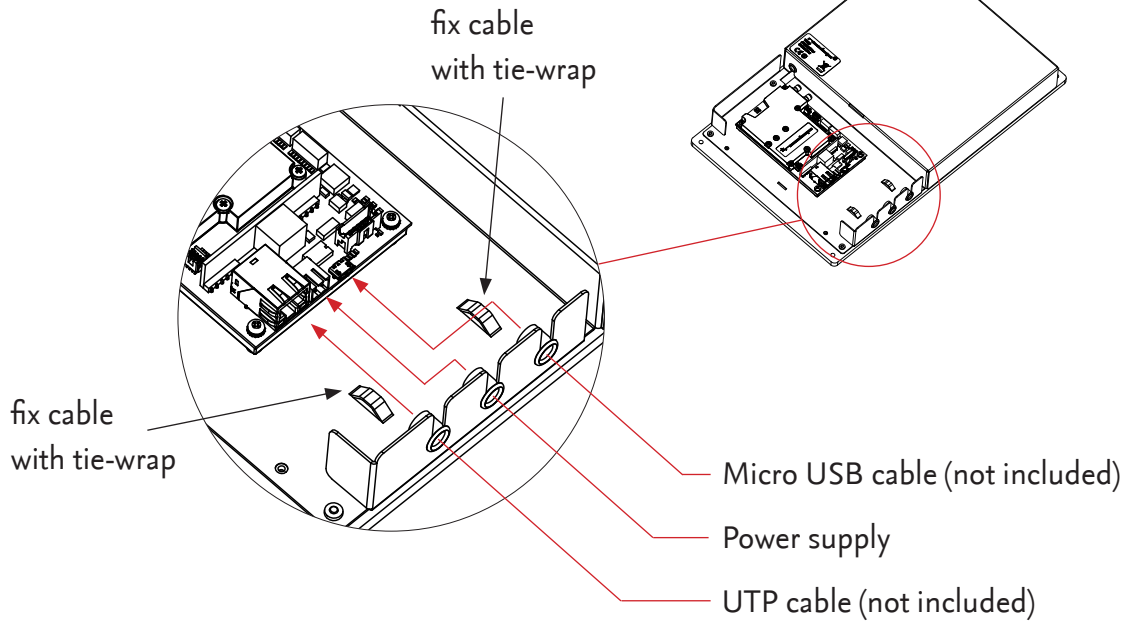
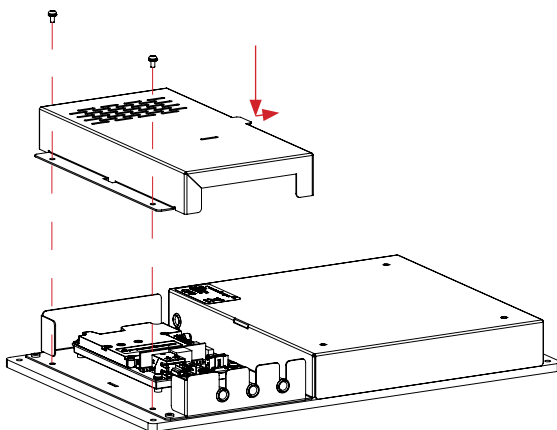

connect voltage supply

Power options:

1. use adapter in box.
2. use IEEE 802.3a* compatible Power over ethernet (not compatible with Nedap Power-over-ethernet inserter used for !D Top or !D Gate)

Driver and config-tool on portal

Model: !D POS Region 2

FCC ID: CGDSTOREIDP IC: 1444A-STOREIDP

This device complies with part 15 of the FCC Rules and to RSS210 of Industry Canada. Operation is subject to the following two conditions:

- (1) this device may not cause harmful interference, and
- (2) this device must accept any interference received, including interference that may cause undesired operation.

Changes or modifications not expressly approved by the party responsible for compliance could void the user's authority to operate the equipment.

Cet appareil se conforme aux normes RSS 210 exemptés de licence du Industry Canada.

L'opération est soumise aux deux conditions suivantes:

- (1) cet appareil ne doit causer aucune interférence, et
- (2) cet appareil doit accepter n'importe quelle interférence, y compris l'interférence qui peut causer une opération non souhaitée de cet appareil.

Les changements ou modifications n'ayant pas été expressément approuvés par la partie responsable de la conformité peuvent faire perdre à l'utilisateur l'autorisation de faire fonctionner le matériel.

FCC and IC Radiation Exposure Statement:

This equipment complies with FCC and Canadian radiation exposure limits set forth for an uncontrolled environment. This equipment should be installed and operated with a minimum distance of 20 cm between the radiator and your body. This transmitter must not be co-located or operating in conjunction with any other antenna or transmitter.

Cet équipement est conforme à RSS-102 limites énoncées pour un environnement non contrôlé. Cet équipement doit être installé et utilisé avec une distance minimale de 20 cm entre le radiateur et votre corps.

This Class B digital apparatus complies with Canadian ICES-003

Cet appareil numérique de Classe B est conforme à la norme Canadienne ICES-003

NOTE: This equipment has been tested and found to comply with the limits for a Class B digital device, pursuant to part 15 of the FCC Rules. These limits are designed to provide reasonable protection against harmful interference in a residential installation. This equipment generates, uses and can radiate radio frequency energy and, if not installed and used in accordance with the instructions, may cause harmful interference to radio communications. However, there is no guarantee that interference will not occur in a particular installation.

If this equipment does cause harmful interference to radio or television reception, which can be determined by turning the equipment off and on, the user is encouraged to try to correct the interference by one or more of the following measures:

- Reorient or relocate the receiving antenna.
- Increase the separation between the equipment and receiver.
- Connect the equipment into an outlet on a circuit different from that to which the receiver is connected.
- Consult the dealer or an experienced radio/TV technician for help.

